



THE DATASHEET OF TMC429-I



TMC429 DATASHEET

Intelligent Triple Stepper Motor Controller with Serial Peripheral Interfaces and Step/Direction
Full Compatible Successor of the TMC428

+



+

APPLICATIONS

CCTV, Security
 Antenna Positioning
 Heliostat Controller
 Battery powered applications
 Office Automation
 ATM, Cash recycler, POS
 Lab Automation
 Liquid Handling
 Medical
 Printer and Scanner
 Pumps and Valves

+

+

FEATURES AND BENEFITS

Controls up to three stepper motors
3.3 V or 5 V operation with CMOS / TTL compatible IOs
Serial 4-wire interface for μC with easy-to-use protocol
Interface for SPI™ motor drivers with data rates up to 1 Mbit/s
Step/Direction interface
Clock frequency: up to 32 MHz (can use CPU clock)
Internal position counters 24 bit wide
Microstep frequency up to 1 MHz
Read-out option for all motion parameters
Programmable 6 bit microstep table, up to 64 entries for a quarter sine wave period
Ramp generators for autonomous positioning / speed control
On-the-fly change of target motion parameters
Power boost automatic acceleration dependent current control
Low power operation: 1.25 mA at 4 MHz (typ.)
Compact Size: ultra small 16 pin SSOP package, small 24 pin SOP package, and 32 pin QFN 5x5 mm package
Directly controls TMC23x, TMC24x, TMC26x, and TMC389

DESCRIPTION

The TMC429 is a miniaturized stepper motor controller with an industry leading feature set. It controls up to three motors via SPI or Step/Direction interface. The SPI interface provides a programmable 6 bit microstep table (64 μsteps / fullstep) for best step accuracy with 2-phase stepper motors. Based on target positions and velocities - which can be altered on the fly - it performs all real time critical tasks autonomously. The TMC429 offers high level control functions for robust and reliable operation. Two separate 4 wire serial peripheral interfaces allow for communication with the microcontroller and with up to three daisy chained stepper motor drivers.

Together with a microcontroller the TMC429 forms a complete motion control system. High integration and small form factor allow for miniaturized designs for cost-effective and highly competitive solutions.

BLOCK DIAGRAM

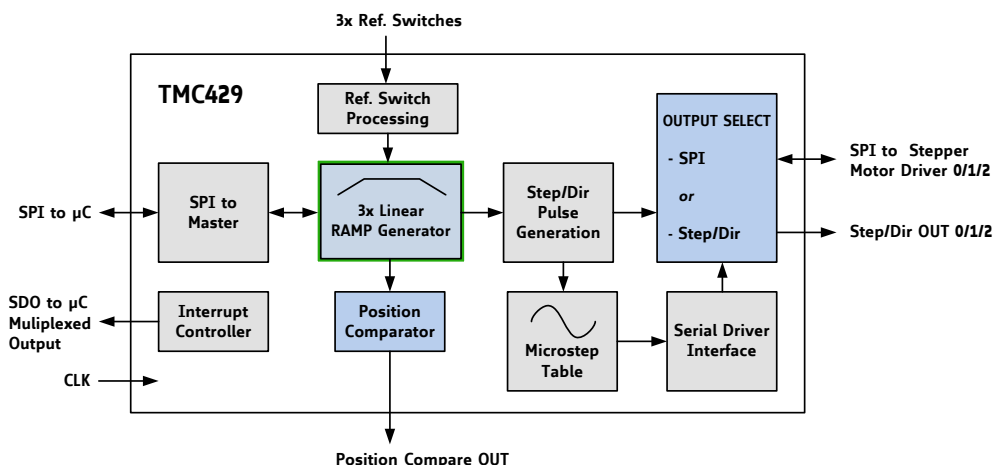

APPLICATION EXAMPLES: RELIABLE CONTROL FOR UP TO 3 MOTORS

The TMC429 scores with its autonomous handling of all real time critical tasks. By offloading the motion-control function to the TMC429, up to three motors can be operated reliably with very little demand for service from the microcontroller. Software only needs to send target positions, and the TMC429 generates precisely timed step pulses by hardware for up to three stepper motor driver chips. Parameters for each motor can be changed on the fly while software retains full control using an SPI bus. This way, high precision and reliable operation is achieved while costs are kept down.

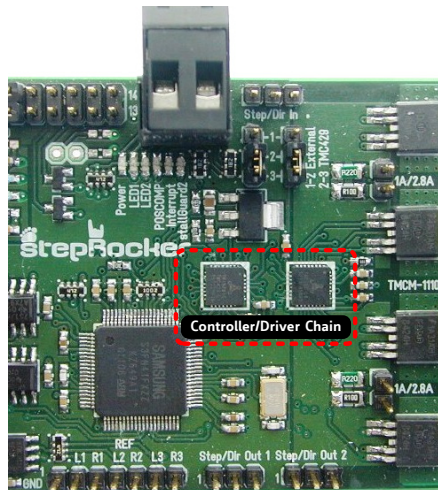

Development platform with TMC262

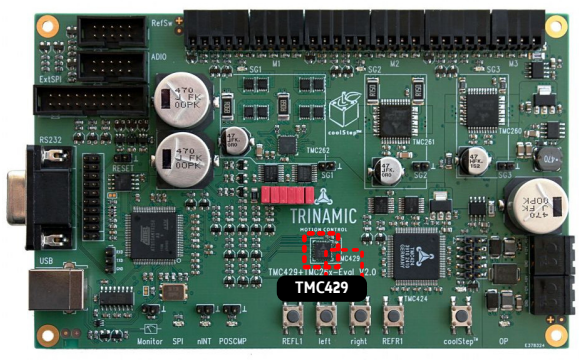

Layout for Evaluation of TMC429 with TMC262, TMC261, and TMC260

STEPROCKER™

The TCM-1110 stepRocker is a single axis motor controller and driver board for 2-phase bipolar stepper motors. It features the TRINAMIC controller/driver chain consisting of TMC429 and TMC262. The Module is intended to be a fully functional development platform with 6A MOSFETs. Because of the TMC429s ability to control up to three motors the stepRocker can be extended to a full 3-axes system.

TMC429+TMC26x-EVAL

This evaluation board is a development platform for applications based on the TMC429 in combination with TMC260, TMC261, and TMC262. Common supply voltages are +12V DC / +24V DC / +48V DC (TMC261 only). The board features an embedded microcontroller with USB and RS232 interfaces. The control software provides a user-friendly GUI for setting control parameters and visualizing the dynamic responses of the motors.

Motor movements can be controlled via the step and direction interface using inputs from an external source or signals generated by the microcontroller acting as a step generator.

ORDER CODES

| Order code | Description | Size |
|--------------------|---|-----------------------------|
| TMC429-LI | 3-axis controller QFN32-package (5x5mm ²), full functionality | 5 x 5 mm ² |
| TMC429-PI24 | 3-axis controller SOP24-package (TMC428 replacement possible) | 15.5 x 10.5 mm ² |
| TMC429-I | 3-axis controller SSOP16-package (SPI only, for TMC428 replacement) | 6 x 5 mm ² |
| TMC429+26x-EVAL | Evaluation board for S/D chipset (TMC429with TMC260, TMC261, TMC262 and TMC424) | 16 x 10 cm ² |
| TMC429+TMC24x-EVAL | Evaluation board for SPI chipset (TMC429, TMC246, and TMC249) | 13.5 x 8,2 cm ² |

TABLE OF CONTENTS

| | | | | | |
|----------|---|-----------|-----------|---|-----------|
| 1 | PRINCIPLES OF OPERATION | 4 | 10 | STEP/DIR DRIVERS | 53 |
| 1.1 | KEY CONCEPTS | 4 | 10.1 | TIMING | 53 |
| 1.2 | CONTROL INTERFACES | 5 | 11 | SPI MODE DRIVER INTERFACE | 54 |
| 1.3 | SOFTWARE VISIBILITY | 6 | 11.1 | BUS SIGNALS | 54 |
| 1.4 | STEP FREQUENCIES | 6 | 11.2 | TIMING | 54 |
| 1.5 | MOVING THE MOTOR | 7 | 11.3 | RAM ADDRESS PARTITIONING AND DATA ORGANIZATION | 55 |
| 2 | GENERAL DEFINITIONS, UNITS, AND NOTATIONS | 9 | 11.4 | STEPPER DRIVER SPI DATAGRAM CONFIGURATION | 57 |
| 2.1 | NOTATIONS | 9 | 11.5 | INITIALIZATION OF MICROSTEP LOOK-UP TABLE | 62 |
| 2.2 | SIGNAL POLARITIES | 9 | 12 | RUNNING A MOTOR | 67 |
| 2.3 | UNITS OF MOTION PARAMETERS | 9 | 12.1 | GETTING STARTED | 67 |
| 2.4 | REPRESENTATION OF SIGNED VALUES BY TWO'S COMPLEMENT | 9 | 12.2 | RUNNING A MOTOR WITH START-STOP-SPEED IN <i>RAMP_MODE</i> | 67 |
| 3 | PACKAGE VARIANTS | 10 | 13 | ON-CHIP VOLTAGE REGULATOR | 68 |
| 4 | PIN ASSIGNMENTS | 10 | 14 | POWER-ON RESET | 69 |
| 4.1 | PACKAGE OUTLINES | 11 | 15 | ABSOLUTE MAXIMUM RATINGS | 70 |
| 4.2 | SIGNAL DESCRIPTIONS | 12 | 16 | ELECTRICAL CHARACTERISTICS | 70 |
| 5 | SAMPLE CIRCUITS | 13 | 16.1 | POWER DISSIPATION | 70 |
| 5.1 | APPLICATION EXAMPLE: TMC429 IN QFN32 PACKAGE | 13 | 16.2 | DC CHARACTERISTICS | 71 |
| 5.2 | APPLICATION EXAMPLE: TMC429 IN SSOP16 PACKAGE | 14 | 16.3 | TIMING CHARACTERISTICS | 72 |
| 5.3 | APPLICATION EXAMPLE: TMC429 WITH DRIVERS WITHOUT SERIAL DATA OUTPUT (SDO) | 14 | 18 | PACKAGE MACHANICAL DATA | 73 |
| 6 | CONTROL INTERFACE | 15 | 18.1 | TMC429-LI / QFN32 | 73 |
| 6.1 | BUS SIGNALS | 15 | 18.2 | TMC429-PI24 / SOP24 | 74 |
| 6.2 | SERIAL PERIPHERAL INTERFACE FOR μ C | 15 | 18.4 | TMC429-I / SSOP16 | 75 |
| 7 | ADDRESS SPACE PARTITIONS | 20 | 19 | MARKING | 76 |
| 7.1 | READ AND WRITE | 20 | 20 | COMPATIBILITY INFORMATION: TMC429 AND TMC428 | 77 |
| 7.2 | REGISTER SET | 20 | 20.1 | SIGNAL DESCRIPTIONS: TMC428 vs. TMC429 | 77 |
| 7.3 | REGISTER MAPPING | 21 | 20.2 | TMC428 SDO_C OUTPUT | 78 |
| 8 | REGISTER DESCRIPTION | 22 | 20.3 | UNUSED ADDRESSES | 78 |
| 8.1 | AXIS PARAMETER REGISTERS | 22 | 20.4 | GENERAL TIMING PARAMETERS | 79 |
| 8.2 | GLOBAL PARAMETER REGISTERS | 39 | 21 | DISCLAIMER | 80 |
| 9 | REFERENCE SWITCH INPUTS | 49 | 22 | ESD SENSITIVE DEVICE | 80 |
| 9.1 | REFERENCE SWITCH CONFIGURATION, <i>MOT1R</i> , AND <i>REFMUX</i> | 49 | 23 | TABLE OF FIGURES | 81 |
| 9.2 | TRIPLE SWITCH CONFIGURATION | 51 | 24 | REVISION HISTORY | 82 |
| 9.3 | HOMING PROCEDURE | 52 | 25 | REFERENCES | 83 |
| 9.4 | SIMULTANEOUS START OF UP TO THREE STEPPER MOTORS | 52 | | | |

1 Principles of Operation

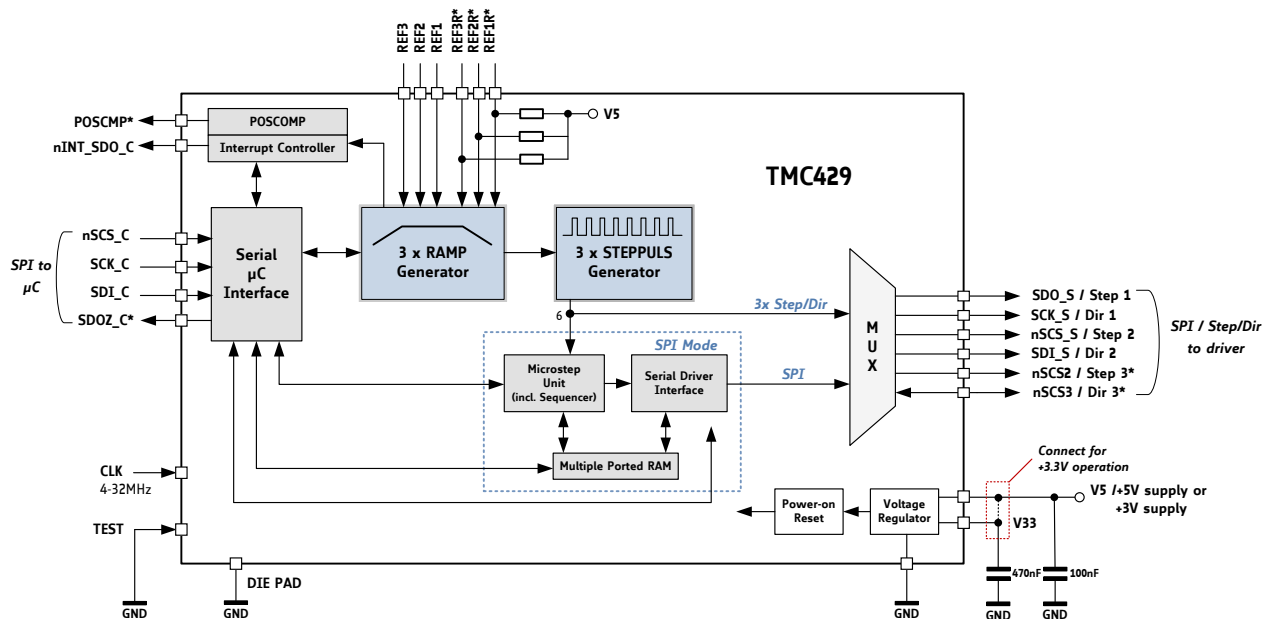

* Not available with all IC packages. Please refer to the package outlines.

Figure 1.1 TMC429 functional block diagram

The TMC429 is a miniaturized high performance stepper motor controller with an outstanding cost-performance ratio. It is designed for high volume automotive as well as for demanding industrial motion control applications. Once initialized the TMC429 controls up to three 2-phase stepper motors simultaneously. A programmable sequencer for 2-phase motors is integrated. The TMC429 motion controller is equipped with an SPI™ host interface with easy-to-use protocol and two driver interfaces (SPI and STEP/DIR) for addressing various stepper motor driver types.

1.1 Key Concepts

The TMC429 realizes real time critical tasks autonomously and guarantees for a robust and reliable drive. These following features contribute toward greater precision, greater efficiency, higher reliability, and smoother motion in many stepper motor applications.

- Initialization** Adapt the TMC429 to the driver type and configuration and send initial configuration data to SPI drivers. Configure microstep resolution and waveform for SPI drivers.
- Interfacing** The TMC429 offers application specific interfacing via Step/Dir or SPI.
- Positioning** The TMC429 operates the motors based on user specified target positions and velocities. Modify all motion target parameters on-the-fly during motion.
- Programming** Every parameter can be changed at any time. The uniform access to any TMC429 register simplifies application programming. A read-back option for all internal registers is available.
- Microstepping** Based on internal position counters the TMC429 performs up to $\pm 2^{23}$ (micro)steps completely independent from the microcontroller. Microstep resolutions are individually programmable for each stepper motor. The range goes from full stepping (1 microstep = 1 full step) and half stepping (2 microsteps per full step) up to 6 bit micro stepping (64 microsteps per full step) for precise positioning and noiseless stepper motor rotation. With STEP/DIR drivers any microstep resolution is possible as supported by the driver. The internal microstep table can be adapted to specific motor characteristics to further reduce torque ripple, if desired.

1.2 Control Interfaces

1.2.1 Serial μ C Interface

From the software point of view, the TMC429 provides a set of registers, accessed by a microcontroller via a serial interface in a uniform way. Each datagram contains address bits, a read-write selection bit, and data bits to access the registers and the on-chip memory. Each time the microcontroller sends a datagram to the TMC429 it simultaneously receives a datagram from the TMC429. This simplifies the communication with the TMC429 and makes programming easy. Most microcontrollers have an SPI hardware interface, which directly connects to the serial four wire microcontroller interface of the TMC429. For microcontrollers without SPI hardware software doing the serial communication is sufficient and can easily be implemented.

1.2.2 Step/Dir Driver Interface

The TMC429-LI controls the motor position by sending pulses on the STEP signal while indicating the direction on the DIR signal. A programmable step pulse length and step frequencies up to 1MHz allow operation at high speed and high microstep resolution. The driver chip converts these signals into the coil currents which control the position of the motor. The TMC429-LI perfectly fits to the TMC26x smart power Step/Dir driver family.

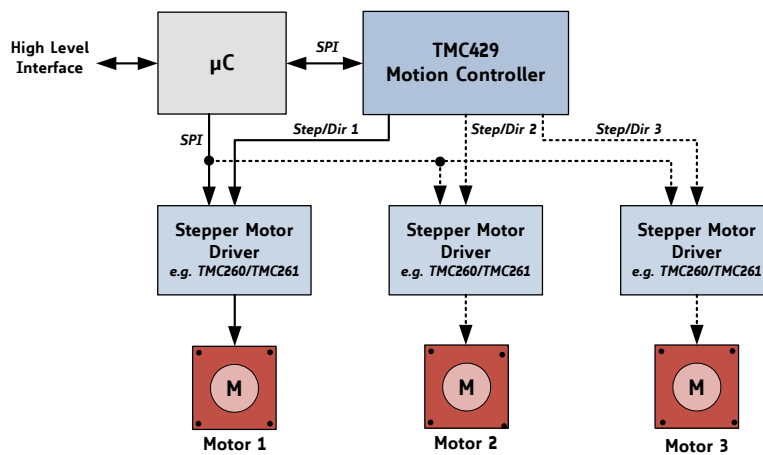

Figure 1.2 Application example using Step/Dir driver interface

1.2.3 Serial Driver Interface

The TMC429 automatically generates the required data-stream for SPI drivers and provides user configurable microstep waves and motor ramps for up to three motors. The serial interface to the motor drivers is flexibly configurable for different types (from different vendors) with up to 64 bit length for the SPI daisy chain. The TMC429-I perfectly fits to the TMC24x driver family.

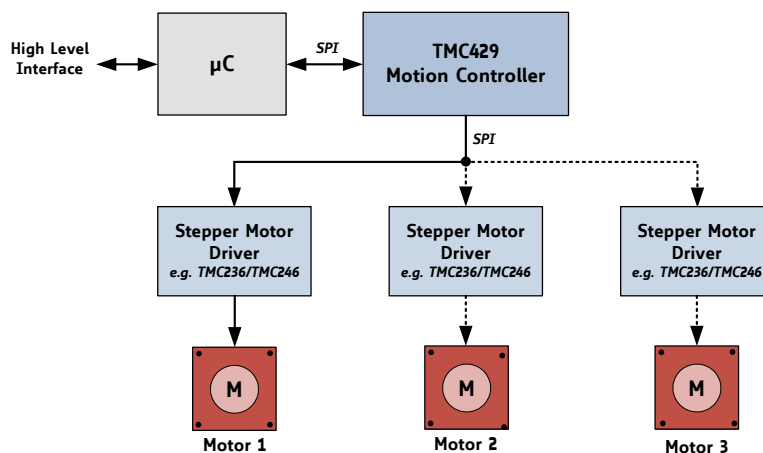

Figure 1.3 Application example using SPI driver interface

1.3 Software Visibility

From the software point of view the TMC429 provides a set of registers and on-chip RAM (see Figure 1.1), accessed via the serial μ C interface in a uniform way. The serial interface uses a simple protocol with fixed datagram length for the read- and write-access. These registers are used for initializing the chip as required by the hardware configuration. Afterwards the motor can be moved by writing target positions or velocity and acceleration values.

1.4 Step Frequencies

The desired motor velocity is an important design parameter of an application. Therefore it is important to understand the limiting factors.

1.4.1 Step Frequencies using the Step/Dir driver interface

The step pulses can directly be fed to a Step/Dir driver. The maximum full step rate (fsf_{max}) depends on the microstep resolution of the external driver chip.

The TMC429 microstep rate (μsf) is up to 1/32 of the clock frequency:

$$\mu sf_{max} = \frac{f_{CLK}}{32}$$

EXAMPLE FOR FULL STEP FREQUENCY CALCULATION

$f_{CLK} = 16 \text{ MHz}$

$\mu sf_{max} = 500 \text{ kHz}$

μ step resolution of external driver: 16

$$fsf_{max} = \frac{500 \text{ kHz}}{16} = 31.25 \text{ kHz}$$

With a standard motor with 1.8° per full step this results in up to $31.25\text{kHz}/200 = 156$ rotations per second, which is far above realistic motor velocities for this kind of motor and thus imposes no real limit on the application.

A 16 microsteps resolution can be extrapolated to 256 microsteps within the driver when using the TMC26x driver family.

1.4.2 Step frequencies using the SPI driver interface

The microstep unit with included sequencer processes step pulses from the pulse generator, which represent microsteps, half steps, or full steps (depending on the selected step resolution). The serial driver interface sends datagrams to the stepper motor driver chain whenever a step pulse comes.

The theoretical microstep frequency is identical to Step/Dir mode, but the achievable step frequency may be limited by the SPI data rate. Maximum SPI frequency (bit rate) is clock frequency divided by 16 (when $CLK2DIV=7$). An overhead of 1.5 bits is required per datagram. The maximum microstep transmission frequency depends on the total length of the datagrams sent to the SPI stepper motor driver chain.

EXAMPLE FOR SPI DATA RATE CALCULATION

At a clock frequency of 16 MHz, with a daisy chain of three SPI stepper motor drivers of 12 bit datagram length each (e.g. TMC246), the theoretical maximum SPI transmission frequency ($f_{SPI_{max}}$) is:

$$f_{SPI_{max}} = \frac{16 \text{ MHz}}{\frac{16}{3 \times 12 + 1.5}}$$

This is approximately 27 kHz. It is the theoretical upper limit for the fullstep frequency. In an application, the maximum desired fullstep frequency should be a factor 4 to 8 lower in order to avoid a beat between the step frequency and the SPI transmission rate.

The microstep rate may be higher than the SPI transmission frequency, even if the stepper motor driver does not note all microsteps due to the SPI data rate limit. At high step rates (respectively pulse rates) the differences between microstepping and full step excitation vanish.

1.5 Moving the Motor

Moving the motor is simple:

- To move a motor to a *new target position*, write the target position into the associated register by sending a datagram to the TMC429.
- To move a motor with a *new target velocity*, write the velocity into the register assigned to the stepper motor.

1.5.1 Motion Controller Functionality

The ramp generator monitors the motion parameters stored in its registers and calculates velocity profiles. Based on the actual ramp generator velocity a pulse generator supplies step pulses to the motor driver.

1.5.2 Modes of Motion – Individually Programmable for Each Axis

| | |
|----------------------|---|
| <i>ramp_mode</i> | For positioning applications the <i>ramp_mode</i> is most suitable. The user sets the position and the TMC429 calculates a trapezoidal velocity profile and drives autonomously to the target position. During motion, the position may be altered arbitrarily. |
| <i>velocity_mode</i> | For constant velocity applications the <i>velocity_mode</i> is most suitable. In <i>velocity_mode</i> , a target velocity is set by the user and the TMC429 takes into account user defined limits of velocity and acceleration. |
| <i>hold_mode</i> | In <i>hold_mode</i> , the user sets target velocities, but the TMC429 ignores any limits of velocity and acceleration, to realize arbitrary velocity profiles, controlled completely by the user. |
| <i>soft_mode</i> | The <i>soft_mode</i> is similar to the <i>ramp_mode</i> , but the decrease of the velocity during deceleration is done with a soft, exponentially shaped velocity profile. |

1.5.3 Interrupts

The TMC429 has capabilities to generate interrupts. Interrupts are based on ramp generator conditions which can be set using an interrupt mask. The interrupt controller (which continuously monitors reference switches and ramp generator conditions) generates an interrupt if required.

SPECIAL HANDLING: TMC429-I / 16-PIN PACKAGE

- On 16-pin package the SDO_C signal becomes a low active interrupt signal called nINT_SDO_C while nSCS_C is high. Set SDO_INT=1 to access the non-multiplexed interrupt signal output nINT_SDO_C for the other packages.
- If the microcontroller disables the interrupt during access to the TMC429 and enables the interrupt otherwise, the multiplexed interrupt output of the TMC429 behaves like a dedicated interrupt output.
- For polling, the TMC429 sends the status of the interrupt signal to the microcontroller with each datagram.

1.5.4 Reference Switch Handling

The TMC429 has a left and a right reference switch input for each motor. Note, that these inputs are not available with all packages.

SPECIAL HANDLING: TMC429-I / 16-PIN PACKAGE

Because of its 16-pin package the TMC429-I has only three reference switch inputs: REF1, REF2, and REF3. Therefore the TMC429-I provides two different modes for reference switch handling:

- In the *Default Reference Switch Mode* the three reference switch inputs are defined as left side reference switches, one for each stepper motor.
- The *Second Reference Switch Mode* defines the first reference input REF1 as left reference switch input of motor one, the second reference input REF2 as left reference switch input of motor two, and the 3rd reference input REF3 as right reference switch input of motor one. In the second reference switch mode there is no reference switch input available for stepper motor three.
- With an external multiplexer 74HC157 any stepper motor may have a left and a right reference switch.

1.5.5 Integrated Programmable μ step Sequencer

The serial SPI interface to the stepper motor driver chain has to be configured by an initialization sequence which writes the configuration into the on-chip RAM. Once configured the serial driver interface works autonomously. The internal multiple port RAM controller of the TMC429 takes care of access scheduling. So, the user may read and write registers and on-chip RAM at any time. The registers hold global configuration parameters and motion parameters. The on-chip RAM stores the configuration of the serial driver interface and the microstep table.

The sequencer internally generates a number of control signals available for transmission to SPI driver ICs. These sequencer output signals are selected as configured by the internal stepper motor driver datagram configuration table.

During power-on reset, the TMC429 initializes a default configuration within the on-chip RAM for an SPI driver chain for TMC23x and TMC24x stepper motor drivers.

1.5.6 Access to Status and Error Bits

STEP/DIR

The microcontroller directly controls and monitors the stepper drivers. It also needs to take care for advanced current control, e.g. power down in stand still.

SPI

Many serial stepper motor drivers provide status bits (driver active, inactive...) and error bits (short to ground, wire open...), which are sent back from the stepper motor driver chain to the motion controller. To have access to error bits and datagrams with a total length up to 48 bits the TMC429 buffers the information by means of two 24 bit wide registers. The microcontroller has direct access to these registers.

Although, the TMC429 provides datagrams with up to 64 bits to the driver chain, only the last 48 bits sent back from the driver chain are buffered for read out by the microcontroller. Buffering of up to 48 bits is sufficient for a chain of three stepper motor drivers. For a chain of three TMC23x / TMC24x stepper motor driver chips all status bits are accessible.

2 General Definitions, Units, and Notations

2.1 Notations

- *Decimal numbers* are used as usual without additional identification.
- *Binary numbers* are identified by a prefixed % character.
- *Hexadecimal numbers* are identified by a prefixed \$ character.

EXAMPLE

Decimal: 42
Binary: %101010
Hexadecimal: \$2A

TMC429 DATAGRAMS ARE WRITTEN AS 32 BIT NUMBERS, E.G.:

\$1234ABCD = %0001 0010 0011 0100 1010 1011 1100 1101

TWO TO THE POWER OF N

In addition to the basic arithmetic operators (+, -, *, /) the operator *two to the power of n* is required at different sections of this data sheet. For better readability instead of 2^n the notation 2^n is used.

2.2 Signal Polarities

External and internal signals are high active per default, but the polarity of some signals is programmable to be inverted. A pre-fixed lower case *n* indicates low active signals (e.g. *nSCS_C*, *nSCS_S*). See chapter 8.2, too.

2.3 Units of Motion Parameters

The motion parameters *position*, *velocity*, and *acceleration* are given as integer values within TMC429 specific units. With a given stepper motor resolution one can calculate physical units for angle, angular velocity, angular acceleration. (See chapter 8.1.13)

2.4 Representation of Signed Values by Two's Complement

Motion parameters which have to cover negative and positive motion direction are processed as signed numbers represented by two's complement as usual. Limit motion parameters are represented as unsigned binary numbers.

SIGNED MOTION PARAMETERS ARE:

V_TARGET / *V_ACTUAL* / *A_ACTUAL* / *A_THRESHOLD*

UNSIGNED MOTION PARAMETERS ARE:

V_MIN / *V_MAX* / *A_MAX*

POSITIONS

X_TARGET / *X_ACTUAL* can be treated as signed or unsigned, as desired.

3 Package Variants

The TMC429 is available in three different package variants, qualified for the industrial temperature range. An additional variant is available for the automotive temperature range. All package variants are RoHS compliant.

| Order code | Package | Characteristics | JEDEC Drawing |
|-------------|---------|---|-------------------|
| TMC429-LI | QFN32 | 5x5mm, 32 pins, plastic package, industrial (-40... +85°C) | |
| TMC429-PI24 | SOP24 | 300 mils, 24 pins, plastic package, industrial (-40... +85°C) | MS-013 (300 mils) |
| TMC429-I | SSOP16 | 150 mils, 16 pins, plastic package, industrial (-40... +85°C) | MO-137 (150 mils) |

4 Pin Assignments

The three package variants of the TMC429 offer different signal sets for various applications:

| Type | Package | Compatibility | Remarks |
|-------------|---------|-------------------------|---|
| TMC429-LI | QFN32 | | <ul style="list-style-type: none"> - Full functionality including SPI and Step/Dir driver interfaces for up to three stepper motor driver chips - Fits best to TMC26x and TMC389. |
| TMC429-PI24 | SOP24 | TMC428-PI24 replacement | <ul style="list-style-type: none"> - SPI interface for up to three stepper driver chips - STEP/DIR interface for up to three stepper driver chips - The right reference switch for motor 3 is not available. |
| TMC429-I | SSOP16 | TMC428-I replacement | <ul style="list-style-type: none"> - SPI interface for up to three stepper motor driver chips (complements the TMC24x). - Step/Dir interface for up to two motors. - The additional reference right side switch inputs REF1R, REF2R, and REF3R are not available. - An additional multiplexer 74hc157 might be necessary. The multiplexing control signal is only available in SPI stepper motor driver chain mode. |

Some third party SPI stepper motor drivers have no serial data output and therefore cannot simply be arranged in a daisy chain to drive more than one motor. The package variants SOP24 and QFN32 have two additional driver selection outputs nSCS2 and nSCS3 for stepper motor drivers without serial data output.

All inputs are Schmitt-Trigger. Unused inputs (REF1, REF2, REF3, and SDI_S) need to be connected to ground. Unused reference switch inputs have to be connected to ground, too. A pull-down resistor is necessary at the SDI_S input of the TMC429 for those serial peripheral interface stepper motor drivers that set their serial data output to high impedance Z while inactive.

STEP function outputs are S1, S2, and S3. Corresponding DIR outputs are D1, D2, and D3. The multiplexed output nINT_SDO_C of TMC429-LI and TMC429-PI24 can be configured in a de-multiplexed mode. An additional output named POSCMP is available for triggering when moving over a programmable position.

Attention

- After power on-reset, the TMC429 starts in TMC428 mode. That is, because the TMC429 is a 100% compatible successor of the TMC428 motion controller. *Additional outputs of the TMC429 including specific functions have to be activated by dedicated TMC429 configuration registers.*
- Preferably, long wires to the reference switch inputs (REF1, REF2, and REF3) should be avoided. For long wires, a low pass filter for spike suppression should be provided (refer the TMC429 evaluation board schematic as example).

4.1 Package Outlines

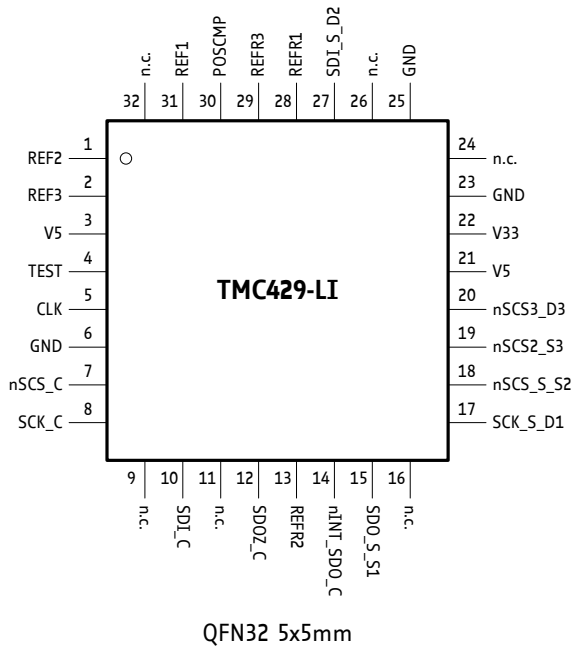

Please refer to the application note **PCB_Guidelines_TRINAMIC_packages** for a practical guideline for all available TRINAMIC IC packages and PCB footprints. The application note covers package dimensions, example footprints and general information on PCB footprints for these packages. It is available on www.trinamic.com.

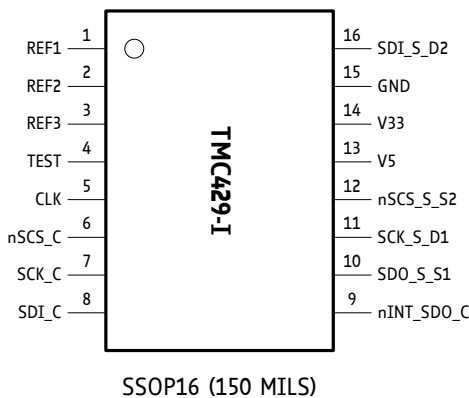
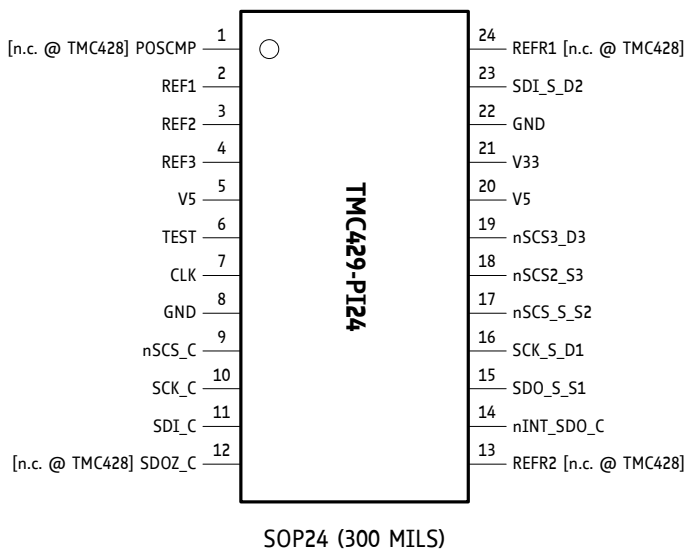

Figure 4.1 TMC429 pin out

4.2 Signal Descriptions

| Pin | SSOP16 | SOP24 | QFN32 | In/Out | Description |
|------------|--------|-------|-----------------------------|------------|--|
| Reset | - | - | - | - | Internal power-on reset. No external reset input pin is available. |
| CLK | 5 | 7 | 5 | I | Clock input |
| nSCS_C | 6 | 9 | 7 | I | Low active SPI chip select input driven from μC |
| SCK_C | 7 | 10 | 8 | I | Serial data clock input driven from μC |
| SDI_C | 8 | 11 | 10 | I | Serial data input driven from μC |
| nINT_SDO_C | 9 | 14 | 14 | 0 | Serial data output to μC input / Multiplexed nINTERRUPT output if communication with μC is idle (resp. nSCS_C = 1) SDO_C will never be high impedance; the TMC429 is equipped with an additional pin named SDOZ_C that becomes high impedance when nSCS_C=1. |
| nSCS_S_S2 | 12 | 17 | 18 | 0 | SPI chip select signal to stepper motor driving chain Step output S2 (for motor 2) in Step/Dir mode |
| nSCS2_S3 | - | 18 | 19 | 0 | SPI chip select signal (SOP24 only) / Step output S3 (for motor 3) in Step/Dir mode |
| nSCS3_D3 | - | 19 | 20 | 0 | SPI chip select signal (SOP24 only) / DIR output D3 (for motor 3) in Step/Dir mode |
| SCK_S_D1 | 11 | 16 | 17 | 0 | Serial data clock output to SPI stepper motor driver chain / DIR output D1 (for motor 1) in Step/Dir mode |
| SDO_S_S1 | 10 | 15 | 15 | 0 | Serial data output to SPI stepper motor driver chain / STEP output S1 (for motor 1) in Step/Dir mode |
| SDI_S_D2 | 16 | 23 | 27 | I 0 | Serial data input from SPI stepper motor driver chain (pull-up/down resistor at SDI_S avoids high impedance; SDI_S input is the power-on default) / DIR output D2 (for motor 2) in Step/Dir mode |
| REF1 | 1 | 2 | 31 | I | Reference switch input 1 (no internal pull-up resistor) |
| REF2 | 2 | 3 | 1 | I | Reference switch input 2 (no internal pull-up resistor) |
| REF3 | 3 | 4 | 2 | I | Reference switch input 3 (no internal pull-up resistor) |
| V5 | 13 | 5, 20 | 3, 21 | | +5V supply / +3.3V supply |
| V33 | 14 | 21 | 22 | | 470nF ceramic capacitor pin / +3.3V supply |
| GND | 15 | 8, 22 | 6, 23, 25 | | Ground |
| TEST | 4 | 6 | 4 | I | <i>Must be connected to GND as close as possible to the chip. No user function.</i> |
| n.c. | - | - | 9, 11, 16, 24, 26, 32 | - | Not connected pins |
| POSCMP | - | 1 | 30 | n.c. / 0 | Position compare output for SOP24 and QFN32 / Output for pos_comp function |
| SDOZ_C | - | 12 | 12 | 0 / Z | SDOZ_C becomes high impedance (Z) when nSCS_C=1 / The nINT signal is not mapped to SDOZ_C pin / <i>The pin nINT_SDO_C can be configured with TMC429 register to give the nINT signal directly without multiplexing</i> |
| REFR1 | - | 24 | 28 | I | Reference switch right 1 input Only available for TMC429 in SOP24 package and QFN32 package (with internal pull-up resistor) |
| REFR2 | - | 13 | 13 | I | Reference switch right 2 input Only available for TMC429 in SOP24 package and QFN32 package (with internal pull-up resistor) |
| REFR3 | - | - | 29 | I | Reference switch right 3 input Only available for TMC429 in QFN32 package (with internal pull-up resistor) |

5 Sample Circuits

The sample circuits show the connection of the external components.

5.1 Application Example: TMC429 in QFN32 Package

All signals of the TMC429 are available with the QFN32 package. We recommend this package for applications using TRINAMICs TMC26x smart power driver family.

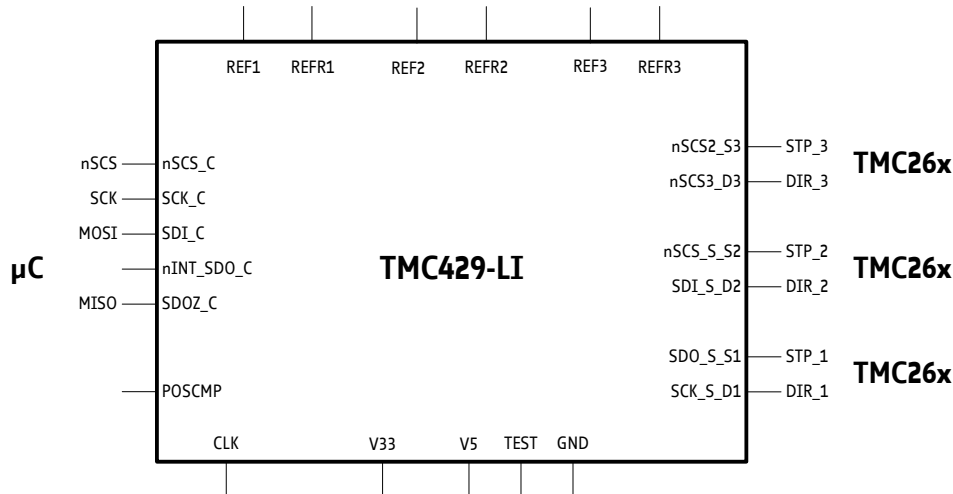

Figure 5.1 TMC429 within QFN32 package

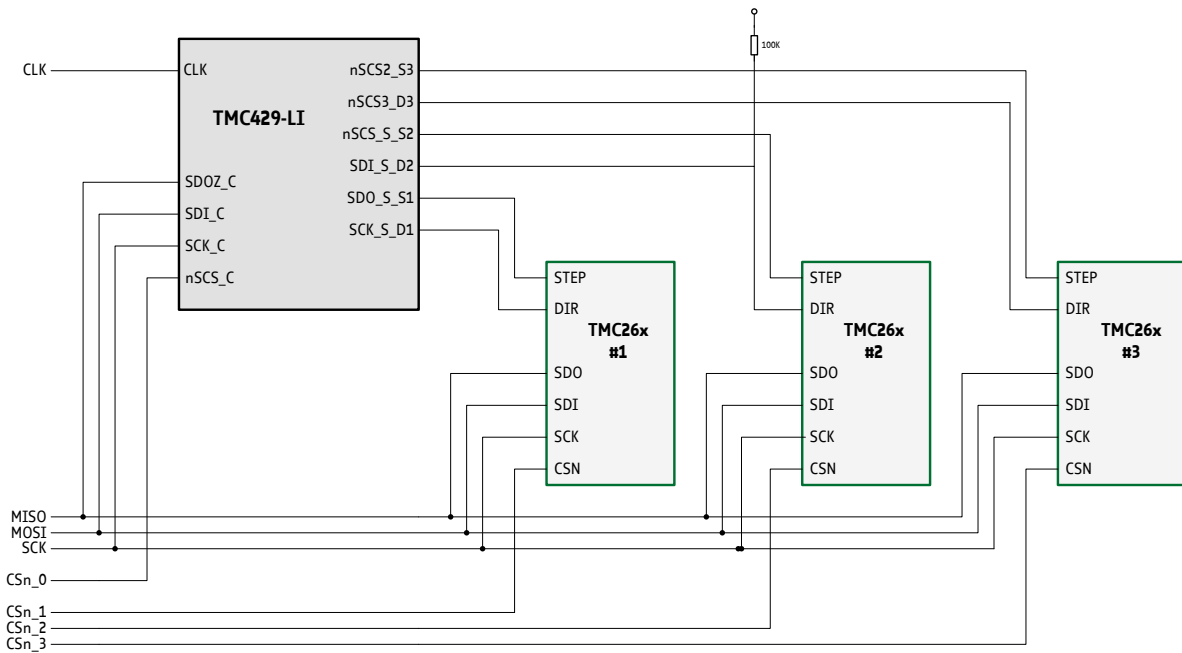

Figure 5.2 TMC429 / TMC26x outline for configuration via SPI and STEP/DIR for motion

APPLICATION ENVIRONMENT OF TMC429 (QFN32 PACKAGE) AND 3 X TMC26X STEPPER MOTOR DRIVER:

- One SPI chip select signal CSN_0 selects the TMC429 SPI microcontroller interface.
- Up to three SPI chip select signals (CSN_3, CSN_2, CSN1) select up to three TMC262 SPI for configuration.
- The TMC429 SDOZ_C is high impedance when nSCS_C is 1.

5.2 Application Example: TMC429 in SSOP16 Package

The low-priced TMC429-I is an optimum choice for SPI stepper motor drivers if the additional functions of the TMC429-LI are not required. We recommend this package for TRINAMICS TMC23x and TMC24x stepper driver family.

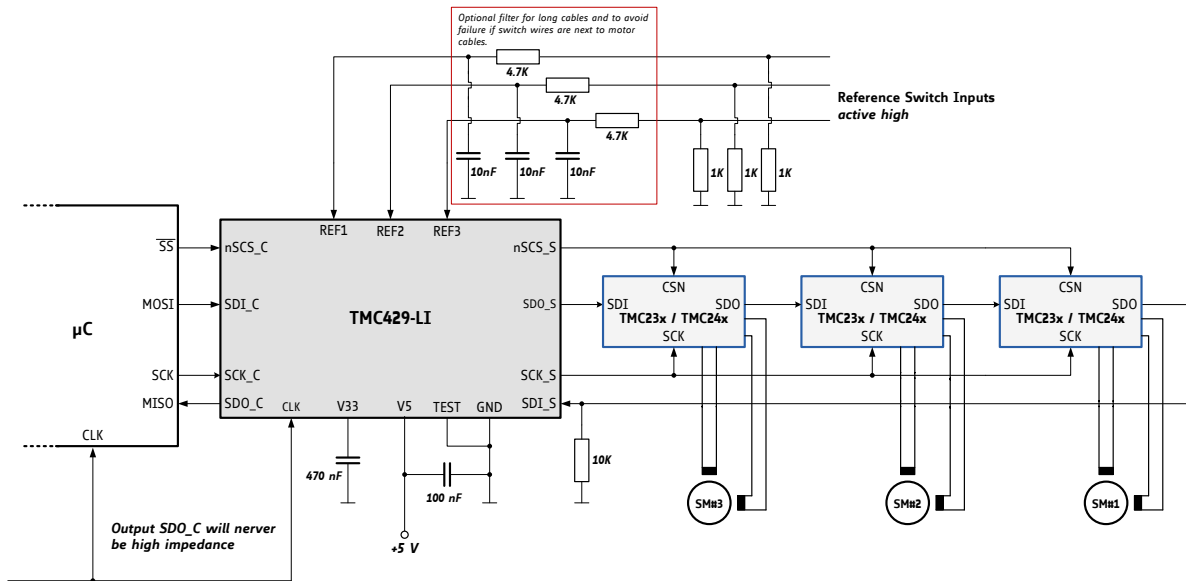

Figure 5.3 TMC429 application environment with TMC429 in SSOP16 package

5.3 Application Example: TMC429 with Drivers without Serial Data Output (SDO)

For driver chips without serial data output the TMC429-LI and the TMC429-PI24 with two additional chip select outputs are available. The TMC429 sends data to the driver chain on demand only, which minimizes the interface traffic and reduces the power consumption.

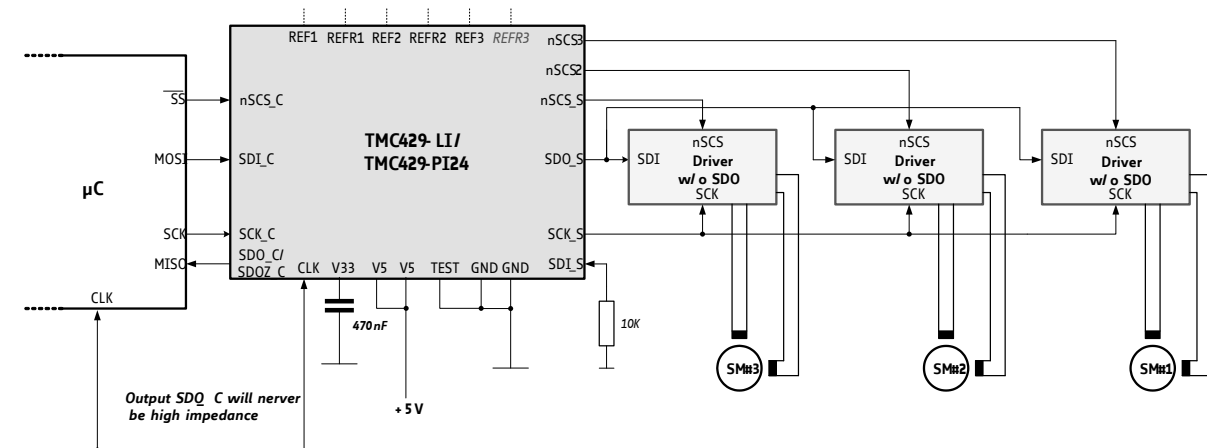

Figure 5.4 Usage of drivers without serial data output (SDO) with TMC429 in SOP24 or in QFN32 packages

6 Control Interface

The communication takes place via four wire serial interfaces and 32 bit datagrams of fixed length. Stepper motor drivers with parallel inputs can be used in connection with the TMC429 with some additional glue logic.

RESPONSIBILITIES ARE DEFINED AS FOLLOWS:

- The microcontroller is master of the TMC429.
- The TMC429 is master of the stepper motor driver daisy chain.

AUTOMATIC POWER-ON RESET:

- The TMC429 cannot be accessed before the power-on reset is completed and the clock is stable.
- All register bits are initialized with 0 during power-on-reset, except the SPI clock pre-divider `clk2_div` that is initialized with 15 (see section 8.2.5.3).

6.1 Bus Signals

| Signal Description | TMC429 ↔ Microcontroller |
|--------------------|--------------------------|
| Bus clock input | SCK_C |
| Serial data input | SDI_C |
| Serial data output | SDO_C |
| Chip select input | nSCS_C |

6.2 Serial Peripheral Interface for μ C

The serial microcontroller interface of the TMC429 acts as a 32 bit shift register.

COMMUNICATION BETWEEN μ C AND THE TMC429

1. The serial μ C interface shifts serial data into SDI_C with each rising edge of the clock signal SCK_C.
2. Then, it copies the content of the 32 bit shift register into a buffer register with the rising edge of the selection signal nSCS_C.
3. The serial interface of the TMC429 immediately sends back data read from registers or read from internal RAM via the signal SDO_C.
4. The signal SDO_C can be sampled with the rising edge of SCK_C. SDO_C becomes valid at least four CLK clock cycles after SCK_C becomes low as outlined in the timing diagram.

6.2.1 Timing

A complete serial datagram frame has a fixed length of 32 bit. Because of on-the-fly processing of the input data stream, the serial μ C interface of the TMC429 requires the serial data clock signal SCK_C to have a minimum low / high time of three clock cycles. The SPI signals from the μ C interface may be asynchronous to the clock signal CLK of the TMC429.

If the microcontroller and the TMC429 work on different clock domains that run asynchronously by the timing of the SPI interface of the microcontroller should be made conservative in the way that the length of one SPI clock cycle equals 8 or more clock cycles of the TMC429 clock CLK.

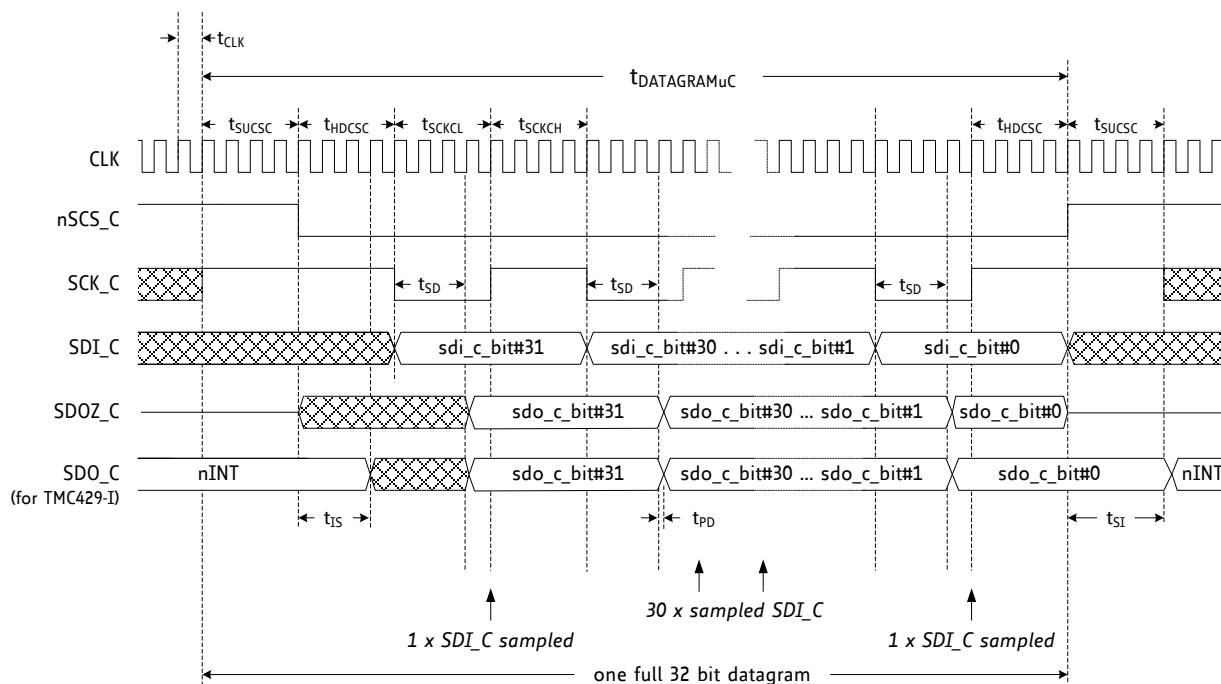

Figure 6.1 Timing diagram of the serial μ C interface

EXPLANATORY NOTES

- While the data transmission from the microcontroller to the TMC429 is idle, the low active serial chip select input nSCS_C and also the serial data clock signal SCK_C are set to high.
- While the signal nSCS_C is high, the TMC429 assigns the status of the internal low active interrupt signal nINT to the serial data output SDO_C.
- The data signal SDI_C driven by the microcontroller has to be valid at the rising edge of the serial data clock input SCK_C. The maximum duration of the serial data clock period is unlimited.
- While the μ C interface of the TMC429 is idle, the SDO_C signal is the (active low) interrupt status nINT of the integrated interrupt controller of the TMC429. The timing of the multiplexed interrupt status signal nINT is characterized by the parameters t_{IS} and t_{SI} (see chapter 16.3).

The following SPI clock frequencies are recommended in order to avoid possible issues concerning the SPI frequency between microcontroller and TMC429:

- For fCLK = 16MHz an upper SPI clock frequency of 1MHz is recommended.
- For fCLK = 32MHz an upper SPI clock frequency of 2MHz is recommended.

PROCEDURE OF DATA TRANSMISSION

1. The signal nSCS_C has to be high for at least three clock cycles before starting a datagram transmission. To initiate a transmission, the signal nSCS_C has to be set to low.
2. Three clock cycles later the serial data clock may go low.
3. The most significant bit (MSB) of a 32 bit wide datagram comes first and the least significant bit (LSB) is transmitted as the last one.
4. A data transmission is finished by setting nSCS_C high three or more CLK cycles after the last rising SCK_C slope.
5. So, nSCS_C and SCK_C change in opposite order from low to high at the end of a data transmission as these signals change from high to low at the beginning.

Information for TMC429-I / 16-pin package

In contrast to most other SPI compatible devices, the serial data output SDO_C of the TMC429-I is always driven. It will never be high impedance Z. If high impedance is required for the SDO_C connected to the microcontroller, it can be realized using a single gate 74HCT1G125. An additional pin named SDOZ_C is available for the TMC429 with an integrated high impedance driver.

NOTE

- Different internal registers of the TMC429 have different lengths. For some registers only a subset of 24 data bits is used.
- Unused data bits should be set to 0.
- Some addresses select a couple of registers mapped together into the 24 data bit space.

6.2.2.2 Datagrams received by μ C from the TMC429

The datagrams received by the μ C from the TMC429 contain two groups of bits:

STATUS BITS The status bits, sent back with each datagram, comprehend the most important internal status bits of the TMC429 and the settings of the reference switches

DATA BITS Data bits are only for write access.

The most significant bit *MSB* is received first; the least significant bit *LSB* is received last. The TMC429 only sends datagrams on demand.

| MSB | 32 BIT DATAGRAM SENT BACK FROM THE TMC429 TO μ C VIA PIN SDO_C | | | | | | | | | | | | | | | | | | | | | | | | LSB | | | | | | |
|-------------|--|-----|-------|-----|-------|-----|-------|---|---|-----------|---|---|---|---|---|---|---|---|---|---|---|---|---|---|-----|---|---|---|---|---|---|
| | 3 | 3 | 2 | 2 | 2 | 2 | 2 | 2 | 2 | 2 | 2 | 2 | 1 | 1 | 1 | 1 | 1 | 1 | 1 | 1 | 1 | 1 | 1 | 1 | | 0 | | | | | |
| 1 | 0 | 9 | 8 | 7 | 6 | 5 | 4 | 3 | 2 | 1 | 0 | 9 | 8 | 7 | 6 | 5 | 4 | 3 | 2 | 1 | 0 | 9 | 8 | 7 | 6 | 5 | 4 | 3 | 2 | 1 | 0 |
| STATUS BITS | | | | | | | | | | DATA BITS | | | | | | | | | | | | | | | | | | | | | |
| INT | CDGW | SM3 | SM2 | SM1 | | | | | | | | | | | | | | | | | | | | | | | | | | | |
| | | RS3 | xEQt3 | RS2 | xEQt2 | RS1 | xEQt1 | | | | | | | | | | | | | | | | | | | | | | | | |

STATUS INFORMATION BITS

| | |
|---------------------|---|
| INT | The status bit <i>INT</i> is the <i>internal high active interrupt controller status output signal</i> . Handling of interrupt conditions without using interrupt techniques is possible by polling this status bit. The interrupt signal is also directly available at the SDO_C pin of the TMC429 (set SDO_INT=1 in if_configuration_429 register). The pin SDO_C may directly be connected to an interrupt input of the microcontroller. Since the SDO_C / nINT output on TMC429-I (16-pin package) is multiplexed, the microcontroller has to disable its interrupt input while it sends a datagram to the TMC429. The SDO_C signal driven by the TMC429 alternates during datagram transmission. |
| CDGW | The CDGW <i>cover datagram waiting</i> bit is a handshake signal for the microcontroller. It shows the state of a datagram covering mechanism that is necessary for direct configuration data transmission to the stepper motor driver chain, e.g. for configuring the drivers in the initialization phase. The CDGW status bit also gives the status of the <i>datagram_high_word</i> and <i>datagram_low_word</i> . |
| RS3, RS2, RS1 | The status bits RS3, RS2 and RS1 represent the state of the left reference switch inputs. They are also accessible in register %1111100 as l3, l2 and l1. |
| xEQt3, xEQt2, xEQt1 | The three status bits xEQt3, xEQt2, and xEQt1 indicate individually for each stepper motor, if it has reached its target position. |

The status bits r1, r2, r3 and l1, l2, l3 and bits xEQt3, xEQt2, and xEQt1 can trigger an interrupt or enable simple polling techniques.

6.2.3 Simple Datagram Examples

The % prefix – normally indicating binary representation in this data sheet – is omitted for the following datagram examples. Assuming, one would like to write (RW=0) to a register (RRS=0) at the address %001101 the following data word %0000 0000 0000 0001 0010 0011, one would have to send the following 32 bit datagram

```
00011010000000000000000100100011
```

to the TMC429. With inactive interrupt (INT=0), no cover datagram waiting (CDGW=0), all reference switches inactive (RS3=0, RS2=0, RS1=0), and all stepper motors at target position (xEQt3=1, xEq2=1, xEq1=1) the status bits would be %10010101 the TMC429 would send back the 32 bit datagram:

```
10010101000000000000000000000000
```

To read (RW=1) back the register written before, one would have to send the 32 bit datagram

```
00011011000000000000000000000000
```

to the TMC429 and the TMC429 would reply with the datagram

```
10010101000000000000000100100011.
```

Write (RW=0) access to on-chip RAM (RRS=1) to an address %111111 occurs similar to register access, but with RRS=1. To write two 6 bit data words %100001 and %100011 to successive pair-wise RAM addresses %1111110 and %1111111 (%100001 to %1111110 and %100011 to %1111111) which are commonly addressed by one datagram, one would have to send the datagram

```
1111111000000000010001100100001.
```

To read (RW=1) from that on-chip memory address, one would have to send the datagram

```
11111111000000000000000000000000.
```

7 Address Space Partitions

The functionality of the TMC429 is mapped to registers which are combined to groups and mapped to the address space:

- Each stepper motor has a set of registers individually assigned to it and arranged within a contiguous address space.
- A set of registers within the address space holds the global parameters which are common for all stepper motors. A single dedicated global parameter register is essential for the configuration of the serial four wire stepper motor driver interface.
- One half of the on-chip RAM address space holds the configuration parameters for the stepper motor driver chain (*used for SPI mode, only*).
- The other half of the on-chip RAM address space is provided to store a microstep table if required (*used for SPI mode, only*).
- The first seven datagram bits (*sdi_c_bit#31* and *sdi_c_bit#30 ... sdi_c_bit#25*, respectively *RRS* and *ADDRESS*) address the whole address space of the TMC429.

| ADDRESS SPACE PARTITIONS | | | | |
|----------------------------|-----|-----------|--|------------------------------|
| Address ranges (incl. RRS) | | | Assignment | |
| %000 0000 | ... | %000 1111 | 16 registers for stepper motor #1 | Registers with up to 24 bits |
| %001 0000 | ... | %001 1111 | 16 registers for stepper motor #2 | |
| %010 0000 | ... | %010 1111 | 16 registers for stepper motor #3 | |
| %011 0000 | ... | %011 1110 | 15 common registers | |
| | | %011 1111 | 1 global parameter register | |
| %100 0000 | ... | %101 1111 | 32 addresses of 2x6 bit for driver chain configuration | RAM |
| %110 0000 | ... | %111 1111 | 32 addresses of 2x6 bit for microstep table | 128x6 bit |

CHANGING TARGET POSITION OR TARGET VELOCITY OF SINGLE MOTORS

The stepper motors are controlled directly by writing motion parameters into associated registers. Only one register write access is necessary for changing a target motion parameter. Thus the microcontroller has to send one 32 bit datagram to the TMC429 for altering the target position or the target velocity of one stepper motor.

CHANGING DRIVER CONFIGURATION OR MICROSTEP TABLE OF ALL MOTORS

Some parameters are packed together in a single data word at a single address. These parameters have to be initialized once and remain unchanged during operation. They have to be changed in common. The access to the on-chip RAM addresses concern two successive RAM addresses. So, always two data words are modified with each write access to the on-chip RAM.

Once initialized after power-up, the content of the RAM is usually left unchanged.

7.1 Read and Write

Read and write access is selected by the RW bit (*sdi_c_bit#24*) of the datagram sent from the μ C to the TMC429. The on-chip configuration RAM and the registers are writeable with read-back option. Some addresses are read-only. Write access (RW=0) to some of those read-only registers triggers additional functions, explained in detail later.

7.2 Register Set

The register address mapping is given in chapter 7.3. The registers are initialized internally during power-up. During power-up initialization, the TMC429 does not send any datagrams to the stepper motor driver chain.

The TMC429 loads a default RAM configuration for a TMC236 / TMC239 / TMC246 / TMC249 SPI driver chain on power-on reset. For a Step/Dir driver chain this is of no relevance.

8 Register Description

The TMC429 provides axis parameter registers and global parameter registers.

8.1 Axis Parameter Registers

The registers hold binary coded numbers. Some are unsigned (positive) numbers, some are signed numbers in two's complement, and some are control bits or single flags. The functionality of different registers depends on the *RAMP_MODE* (refer to chapter 8.1.11).

OVERVIEW AXIS PARAMETER REGISTER MAPPING

| REGISTER | R / W | TYPE | DESCRIPTION |
|--|--------------------------|--|---|
| <i>X_TARGET</i> | R/W | 24 bit | This register holds the current target position in units of microsteps. Positions can be treated as signed or unsigned. |
| <i>X_ACTUAL</i> | R/W* ² | 24 bit | The current position of each stepper motor is available by read out of this register. Positions can be treated as signed or unsigned. |
| <i>V_MIN</i> | R/W | 11 bit unsigned | This register holds the absolute velocity value at or below which the stepper motor can be stopped abruptly. |
| <i>V_MAX</i> | R/W | 11 bit unsigned | This parameter sets the maximum motor velocity. |
| <i>V_TARGET</i> | R/W | 12 bit signed | The <i>V_TARGET</i> register holds the current target velocity. The use of <i>V_TARGET</i> depends on the chosen mode of operation. |
| <i>V_ACTUAL</i> | R* ¹ | 12 bit signed | This read-only register holds the current velocity of the associated stepper motor. |
| <i>A_MAX</i> | R/W | 11 bit unsigned | This register defines the absolute value of the desired acceleration for <i>velocity_mode</i> and <i>ramp_mode</i> (resp. <i>soft_mode</i>) with a value range from 0 to 2047. |
| <i>A_ACTUAL</i> | R | 12 bit signed | The actual acceleration can be read out by the microcontroller from the <i>A_ACTUAL</i> read-only register. |
| <i>IS_AGTAT</i> <i>IS_ALEAT</i> <i>IS_VO</i> <i>A_THRESHOLD</i> | R/W R/W R/W R/W | 3 bit 3 bit 3 bit 11 bit unsigned | These parameters control the current scaling values <i>I_s</i> in SPI driver mode. Depending on the ramp phase they are applied to the motor by scaling the amplitudes of the internal sequencer. |
| <i>PMUL</i> <i>PDIV</i> | R/W R/W | 1+7 bit 4 bit unsigned | These values form a floating point number with <i>PMUL</i> as mantissa and <i>PDIV</i> as exponent. <i>PMUL</i> and <i>PDIV</i> are used for calculating the deceleration ramp. |
| <i>RAMP_MODE</i> <i>REF_CONF</i> <i>lp</i> | R/W R/W R | 2 bit 4 bit 1 bit | The two bits <i>RAMP_MODE</i> (<i>R_M</i>) select one of the four possible modes of operation. The configuration bits <i>REF_CONF</i> select the behavior of the reference switches. The bit called <i>lp</i> (latched position) is a read only status bit. |
| <i>INTERRUPT_MASK</i> <i>INTERRUPT_FLAGS</i> | R/W R/W | 8 bit 8 bit | The TMC429 provides one interrupt register of eight flags for each stepper motor. |
| <i>RAMP_DIV</i> <i>PULSE_DIV</i> <i>USRS</i> | R/W R/W R/W | 4 bit 4 bit 2 bit | The parameter <i>RAMP_DIV</i> scales the acceleration parameter <i>A_MAX</i> . The pulse generator clock – defining the maximum step pulse rate – is determined by the parameter <i>PULSE_DIV</i> . The parameter <i>PULSE_DIV</i> scales the velocity parameters. The parameter <i>USRS</i> (μstep resolution selection) is used for setting the microstep resolution in SPI mode. |
| <i>DX_REF_TOLERANCE</i> | R/W | 12 bit | <i>DX_REF_TOLERANCE</i> excludes a motion range to allow motion near the reference position. |
| <i>X_LATCHED</i> | R | 24 bit unsigned | This read-only register stores the actual position <i>X_ACTUAL</i> upon a change of the reference switch-state. |
| <i>USTEP_COUNT_429</i> | R/W | 8 bit | The read-write register <i>USTEP_COUNT_429</i> holds the actual microstep pointer of the internal sequencer. |

*¹ in *hold_mode* only, this register is a read-write register.

*² before overwriting *X_ACTUAL* choose *velocity_mode* or *hold_mode*. Refer to chapter 8.1.2.

8.1.1 X_TARGET (IDX=%0000)

This register holds the current target position in units of microsteps.

UNIT OF TARGET POSITION

The unit of the target position depends on the setting of the associated microstep resolution register *usrs*.

POSITIONING

- If the difference *X_TARGET* to *X_ACTUAL* is not zero and *R_M* = *ramp_mode* or *soft_mode*, the TMC429 moves the stepper motor in the direction of *X_TARGET* in order to position *X_ACTUAL* to *X_TARGET*. Usually *X_TARGET* is modified to start a positioning.
- The condition $|X_TARGET - X_ACTUAL| < 2^{23}$ must be satisfied for motion into correct direction.
- Target position *X_TARGET* and current position *X_ACTUAL* may be altered on the fly.
- To move from one position to another, the ramp generator of the TMC429 automatically generates ramp profiles in consideration of the velocity limits *V_MIN* and *V_MAX* and acceleration limit *A_MAX*.

The registers *X_TARGET*, *X_ACTUAL*, *V_MIN*, *V_MAX*, and *A_MAX* are initialized with zero after power up.

8.1.2 X_ACTUAL (IDX=%0001)

The current position of each stepper motor is available by read out of the registers called *X_ACTUAL*. The actual position can be overwritten by the microcontroller. This feature is important for the reference switch position calibration controlled by the microcontroller.

UNIT OF CURRENT POSITION

The unit of the target position depends on the setting of the associated microstep resolution register *usrs*.

Attention

Before overwriting *X_ACTUAL* choose *velocity_mode* or *hold_mode*.

If *X_ACTUAL* is overwritten in *ramp_mode* or *soft_mode* the motor directly drives to *X_TARGET*.

8.1.3 V_MIN (IDX=%0010)

This register holds the absolute velocity value at or below which the stepper motor can be stopped abruptly.

UNIT OF VELOCITY

The unit of velocity parameters is *steps per time unit*. The scale of velocity parameters (V_MIN , V_MAX , V_TARGET , V_ACTUAL) is defined by the parameter $PULSE_DIV$ (see page 8.1.13 for details) and depends on the clock frequency of the TMC429.

DECELERATION

- The parameter V_MIN is relevant for deceleration while reaching a target position. V_MIN should be set greater than zero.
- This control value allows reaching the target position faster because the stepper motor is not slowed down below V_MIN before the target is reached.
- Due to the finite numerical representation of integral relations the target position cannot be reached exactly, if the calculated velocity is less than one, before the target is reached. Setting V_MIN to at least one assures reaching each target position exactly.

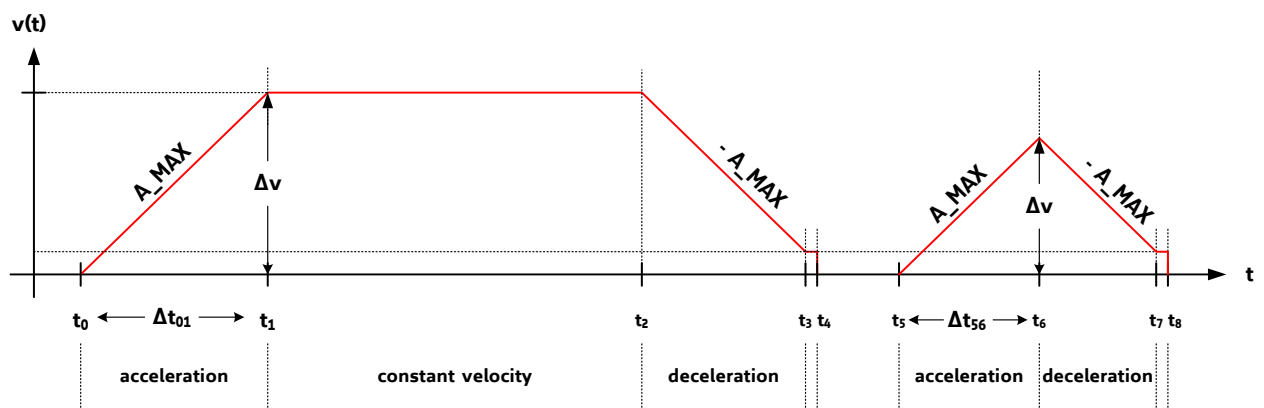

Figure 8.1 Velocity ramp parameters and velocity profiles

8.1.4 V_MAX (IDX=%0011)

This parameter sets the maximum motor velocity. The absolute value of the velocity will not exceed this limit, except if the limit V_MAX is changed during motion to a value below the current velocity.

UNIT OF VELOCITY

The unit of velocity parameters is *steps per time unit*. The scale of velocity parameters (V_MIN , V_MAX , V_TARGET , V_ACTUAL) is defined by the parameter $PULSE_DIV$ (see page 8.1.13 for details) and depends on the clock frequency of the TMC429.

HOMING PROCEDURE

To set target position X_TARGET and current position X_ACTUAL to an equivalent value (e.g. to set both to zero at a reference point) the assigned stepper motor should be stopped first and the parameter V_MAX should be set to zero to hold the assigned stepper motor at rest before writing into the register X_TARGET and X_ACTUAL .

Attention

Before overwriting X_ACTUAL choose *velocity_mode* or *hold_mode*.

If X_ACTUAL is overwritten in *ramp_mode* or *soft_mode* the motor directly drives to X_TARGET .

8.1.5 V_TARGET (IDX=%0100)

The use of V_TARGET depends on the chosen mode of operation:

| Mode of operation | Functionality of V_TARGET |
|----------------------|---|
| <i>ramp_mode</i> | The V_TARGET register holds the current target velocity calculated internally by the ramp generator. |
| <i>velocity_mode</i> | A target velocity can be written into the V_TARGET register. The associated stepper motor accelerates until it reaches the specified target velocity. The velocity is changed according to the motion parameter limits if the register V_TARGET is changed. |
| <i>hold_mode</i> | The register V_TARGET is ignored. |
| <i>soft_mode</i> | The V_TARGET register holds the current target velocity calculated internally by the ramp generator. |

UNIT OF VELOCITY

The unit of velocity parameters is *steps per time unit*. The scale of velocity parameters (V_MIN , V_MAX , V_TARGET , V_ACTUAL) is defined by the parameter $PULSE_DIV$ (see chapter 8.1.13 for details) and depends on the clock frequency of the TMC429.

8.1.6 V_ACTUAL (IDX=%0101)

This read-only register holds the current velocity of the associated stepper motor. Internally, the ramp generator of the TMC429 processes with 20 bits while only 12 bits (the most significant bits) can be read out as V_ACTUAL .

In *hold_mode* only, this register is a read-write register. Writing zero to the register V_ACTUAL immediately stops the associated stepper motor, because hidden bits are set to zero with each write access to the register V_ACTUAL . In *hold_mode* motion parameters are ignored and the microcontroller has the full control to generate a ramp. The TMC429 only handles the microstepping and datagram generation for the associated stepper motor of the daisy chain.

UNIT

The unit of velocity parameters is *steps per time unit*. The scale of velocity parameters (V_MIN , V_MAX , V_TARGET , and V_ACTUAL) is defined by the parameter $PULSE_DIV$ (see chapter 8.1.13 for details) and depends on the clock frequency of the TMC429.

An actual velocity of zero read out by the microcontroller means that the *current velocity is in an interval between zero and one*. Therefore the actual velocity should not be used to detect a stop of a stepper motor. It is advised to detect the *target_reached* flag instead.

8.1.7 A_MAX (IDX=%0110)

This register defines the absolute value of the desired acceleration for *velocity_mode* and *ramp_mode* (resp. *soft_mode*) with a value range from 0 to 2047.

Note

The motion controller cannot stop the stepper motor if A_MAX is set to zero on the fly because afterwards the velocity cannot be changed automatically any more.

UNIT

The unit of the acceleration is *change of step frequency per time unit divided by 256*. The scale of acceleration parameters (A_MAX , A_ACTUAL , and $A_THRESHOLD$) is defined by the parameter $RAMP_DIV$ (see section 8.1.13) and depends on the clock frequency of the TMC429.

8.1.7.1 A_MAX in *ramp_mode*

As long as $RAMP_DIV \geq PULSE_DIV - 1$ is valid, any value of A_MAX within its range (0.. 2047) is allowed and there exists a valid pair $\{PMUL, PDIV\}$ for each A_MAX . The reason is that the acceleration scaling determined by $RAMP_DIV$ is compatible with the step velocity scaling determined by $PULSE_DIV$. A large $RAMP_DIV$ stands for low acceleration and a large $PULSE_DIV$ stands for low velocity. Low acceleration is compatible with low speed and high speed as well, but high acceleration is more compatible with high speed.

Changing one parameter out of the triple $\{A_MAX, RAMP_DIV, PULSE_DIV\}$ requires re-calculation of the parameter pair $\{PMUL, PDIV\}$ to update the associated register. For description of the parameters $PMUL$ and $PDIV$ see section 8.1.10.

8.1.7.1.1 Deceleration in *ramp_mode* and *soft_mode*

If $RAMP_DIV$ and $PULSE_DIV$ differ more than one while deceleration in *ramp_mode* or *soft_mode* the parameter A_MAX needs to have a lower limit (>1) and an upper limit (<2047). The reason is that the deceleration ramp is internally limited to 2^{19} steps (respectively microsteps).

THE LOWER LIMIT OF A_MAX IS GIVEN BY

$$A_MAX_{LOWER_LIMIT} = 2^{(RAMP_DIV - PULSE_DIV - 1)}$$

- With V_MAX set to $\frac{2048}{\sqrt{2}}$ (≈ 1448) or lower the $A_MAX_{LOWER_LIMIT}$ is half of this value.
- If $RAMP_DIV - PULSE_DIV - 1 \leq 0$ the limit $A_MAX_{LOWER_LIMIT}$ is 1 and the parameter A_MAX may be set to 1.

THE UPPER LIMIT OF A_MAX IS GIVEN BY

$$A_MAX_{UPPER_LIMIT} = 2^{(RAMP_DIV - PULSE_DIV + 12)} - 1$$

- If $RAMP_DIV - PULSE_DIV + 1 \geq 0$ the $A_MAX_{UPPER_LIMIT}$ is > 2048 and the parameter A_MAX might be set to any value up to 2047.

CONDITIONS

The parameter A_MAX must not be set below $A_MAX_{LOWER_LIMIT}$ except A_MAX is set to 0. The condition $A_MAX \geq A_MAX_{LOWER_LIMIT}$ as well as $A_MAX \leq A_MAX_{UPPER_LIMIT}$ must be satisfied to reach any target position without oscillations. If that condition is not satisfied, oscillations around a target position may occur.

8.1.8 A_ACTUAL (IDX=%0111)

The actual acceleration can be read out by the microcontroller from the A_ACTUAL read-only register. The actual acceleration is used to select scale factors for the coil currents. It is updated with each clock. The returned value A_ACTUAL is smoothed to avoid oscillations of the readout value. Thus, returned A_ACTUAL values should not be used directly for precise calculations.

UNIT

The unit of the acceleration is *change of step frequency per time unit divided by 256*. The scale of acceleration parameters (A_MAX , A_ACTUAL , and $A_THRESHOLD$) is defined by the parameter $RAMP_DIV$ (see section 8.1.13) and depends on the clock frequency of the TMC429.

8.1.9 IS_AGTAT , IS_ALEAT , IS_V0 , and $A_THRESHOLD$ (IDX=%1000)

These parameters are only relevant in SPI mode. The parameters IS_AGTAT , IS_ALEAT , IS_V0 , and $A_THRESHOLD$ represent the current scaling values I_s . Depending on the ramp phase they are applied to the motor by scaling the current amplitudes of the internal sequencer.

The automatic motion dependent current scale feature of the TMC429 is provided primarily for microstep operation. It may also be applied for full step or half step drivers, if those provide current control bits. In this special case it is possible to initialize the microstep table with a constant function, square function or sine wave using the two most significant DAC bits.

IS_AGTAT The parameter IS_AGTAT is applied if the acceleration is greater than the threshold acceleration. *This is used to increase current during acceleration phases.*

IS_ALEAT The parameter IS_ALEAT is applied if the acceleration is lower than or equal to the threshold acceleration. *This is the nominal motor current.*

IS_V0 The third parameter IS_V0 is applied if the stepper motor is at rest. The parameter is used to save power, keep it cool, and avoid noise probably caused by chopper drivers.

$A_THRESHOLD$ The parameter $A_THRESHOLD$ is the threshold used for comparing with the current acceleration in order to select the current scale factor.

RELATIONSHIP BETWEEN IS_AGTAT , IS_ALEAT , AND IS_V0 AND THE INTERIM BIT VECTOR I_SCALE

The parameters IS_AGTAT , IS_ALEAT , and IS_V0 are bit vectors of three bit width. One of these bit vectors is selected conditionally and assigned to the interim bit vector I_SCALE .

| I_SCALE | | | I_S | | |
|------------|---|---|-------|--------|---|
| 0 | 0 | 0 | 1 | = 100 | % |
| 0 | 0 | 1 | 1 / 8 | = 12.5 | % |
| 0 | 1 | 0 | 2 / 8 | = 25 | % |
| 0 | 1 | 1 | 3 / 8 | = 37.5 | % |
| 1 | 0 | 0 | 4 / 8 | = 50 | % |
| 1 | 0 | 1 | 5 / 8 | = 62.5 | % |
| 1 | 1 | 0 | 6 / 8 | = 75 | % |
| 1 | 1 | 1 | 7 / 8 | = 87.5 | % |

NOTE

- The maximum current scaling factor 1 is selected by $I_SCALE = \%000$. This is the power-on default.
- The minimum current scaling factor $1/8 = 0.125$ is selected by $I_SCALE = \%001$.
- The current scaling factor I_S proportionally reduces the effective number of microsteps per full step. For example, with $I_SCALE = \%100 (= 4/8 = 50\%)$ the number of effective microsteps per full step is halved.
- When a low current scaling factor I_S becomes used, the effective number of microsteps per full step may decrease, because less DAC steps are used to distinguish the same number of current levels. Therefore, it is advised to operate the application normally at 50% to 100% current scale.

The current scale selection scheme shows which of the scale factors IS_AGTAT , IS_ALEAT , and IS_V0 is selected corresponding to their conditions:

If the velocity is zero, the parameter IS_V0 is used for scaling.

If the velocity is not zero, either IS_ALEAT or IS_AGTAT is used for scaling. This depends on the absolute value of the acceleration and the acceleration threshold $A_THRESHOLD$.

| CURRENT SCALE SELECTION SCHEME | | |
|--------------------------------|-------------------------|------------------------------|
| Velocity value | $A_THRESHOLD$ value | I_S scale factor selection |
| $v = 0^{*1)}$ | | $I_S := IS_V0^{*2)}$ |
| $v \neq 0$ | $A_THRESHOLD > 1023$ | $I_S := IS_ALEAT^{*3)}$ |
| | $ a \leq A_THRESHOLD$ | $I_S := IS_ALEAT$ |
| | $ a > A_THRESHOLD$ | $I_S := IS_AGTAT$ |

*1) The configuration bit *continuous_update* of the stepper motor global parameter register must be set to 1 to make sure that the coil current is scaled for $v=0$ if all motors are at rest. The current scale for $V=0$ takes place delayed to avoid mechanical step loss due to oscillations of the motor after it has been stopped.

$$\text{The delay time is: } t_{IS_V0_DELAY[S]} = \frac{255 \times (32 \times 2^{RAMP_DIV})}{f_{CLK[HZ]}}$$

*2) For selection of current scaling IS_V0 (at rest) IS_AGTAT and IS_ALEAT must be larger than 0.

*3) It is not advised to use $A_THRESHOLD > 1023$. Due to comparing of $A_THRESHOLD$ with A_MAX a setting of $A_THRESHOLD$ with a value greater than 1023 results in using IS_ALEAT if A_MAX is greater than 1023 during acceleration.

For most applications setting IS_ALEAT and IS_AGTAT to the same value and using a lower value for IS_V0 is the best choice.

8.1.10 PMUL & PDIV (IDX=%1001)

In ramp mode, the TMC429 uses an internal algorithm to calculate the deceleration ramp on the fly. This algorithm requires an additional proportionality factor P which allows the TMC429 to calculate the velocity required for stopping in time to exactly reach the target position without overshooting. This calculation is done for each ramp step. The result of this calculation can be read in the register V_TARGET . Whenever V_TARGET falls below the actual velocity, the TMC429 decelerates. As there is a large range of acceleration and velocity values, p is stored in a floating point representation, using the registers $PMUL$ (mantissa) and $PDIV$ (exponent).

Using the *proportionality factor* P target positions are quickly reached without overshooting. The proportionality factor primarily depends on the acceleration limit A_MAX and on the two clock divider parameters $PULSE_DIV$ and $RAMP_DIV$. These two separate clock divider parameters (set to the same value for most applications) provide an extremely wide dynamic range for acceleration and velocity. $PULSE_DIV$ and $RAMP_DIV$ allow reaching very high velocities with very low acceleration.

Changing one parameter out of the triple $\{A_MAX, RAMP_DIV, PULSE_DIV\}$ requires re-calculation of the parameter pair $\{PMUL, PDIV\}$ to update the associated register.

8.1.10.1 Calculation of the Proportionality Factor p

The representation of the proportionality factor p by the two parameters $PMUL$ and $PDIV$ is a floating point representation.

NOTATIONS

Registers are $PMUL$ and $PDIV$.

Operating values are P_{MUL} and P_{DIV} .

CALCULATE P AS FOLLOWS:

$$p = \frac{P_{MUL}}{P_{DIV}}$$

with

$$P_{MUL} = 128 \dots 255 \text{ representing a factor of } 1.000 \text{ to } 1.992 (=1+127/128)$$

$$P_{DIV} = \{2^3, 2^4, 2^5 \dots 2^{14}, 2^{15}, 2^{16}\}$$

P_{MUL} ranges from 128 to 255. P_{DIV} is a power of two with a range from 8 to 65536. Values of p less than 128 can be achieved by increasing P_{DIV} .

The TMC429 does not directly store the P_{DIV} parameter. The motion controller stores $PDIV$ with

$$P_{DIV} = 2^{3+PDIV}$$

NOTE

- Setting the factor p too small will result in a slow approach to the target position.
- Setting the factor p too large will cause overshooting and even oscillations around the target position.
- The parameters $PMUL$ and $PDIV$ share the address $IDX=\%1001$. The MSB of $PMUL$ is fixed set to 1 and cannot be changed. This way, $PMUL$ represents a mantissa in the range 1.000 (%1000 0000) to 1.992 (%1111 1111).

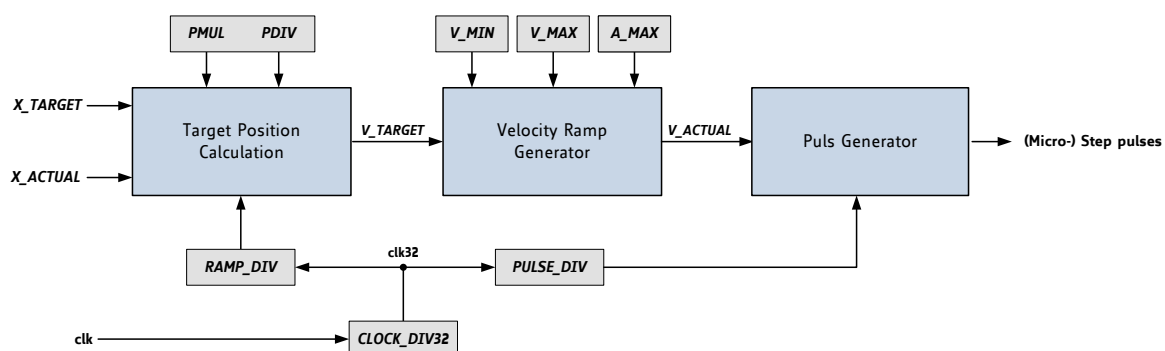

Figure 8.2 Target position calculation, ramp generator, and pulse generator

8.1.10.1 Calculation of p for a Given Acceleration

p and the fitting $PMUL$ and $PDIV$ values can be calculated by the microcontroller. Optionally a pair of matching values of A_MAX , $PMUL$ and $PDIV$ can be stored into the microcontroller memory. The acceleration limit is a stepper motor parameter which is fixed in most applications. If the acceleration limit has to be changed nevertheless, the microcontroller can calculate a pair of $PMUL$ and $PDIV$ on demand for each new acceleration limit A_MAX with $RAMP_DIV$ and $PULSE_DIV$. Also, pre-calculated pairs of $PMUL$ and $PDIV$ read from a table can be sufficient.

8.1.10.2 Calculation of $PMUL$ and $PDIV$

A pair of $PMUL$ and $PDIV$ has to be calculated for each provided acceleration limit A_MAX . Note, that there may be more than one valid pair of $PMUL$ and $PDIV$ for a given A_MAX acceleration limit.

CONSIDERATIONS FOR THE CALCULATION OF $PMUL$ AND $PDIV$

- To accelerate, the ramp generator accumulates the acceleration value to the actual velocity with each time step.
- The absolute value V_MAX of the velocity internally is represented by 11+8=19 bits, while only the most significant 11 bits and the sign are used as input for the step pulse generator. So, there are $2^{11}=2048$ values possible for specifying a velocity within a range of 0 to 2047.
- The ramp generator accumulates $1/256 \cdot A_MAX$ with each time step to the actual velocity value V_ACTUAL during acceleration phases. This accumulation uses 8 bits for decimals. So, the acceleration from a velocity $V_ACTUAL=0$ to the maximum possible velocity $V_MAX=2047$ spans over $2048 \cdot 256 / A_MAX$ pulse generator clock pulses.
- Within the acceleration phase the pulse generator generates $S = \frac{1}{2} \cdot 2048 \cdot 256 / A_MAX \cdot T$ steps for the (micro) step unit.
- The parameter T is the clock divider ratio: $T = 2^{RAMP_DIV} / 2^{PULSE_DIV} = 2^{RAMP_DIV - PULSE_DIV}$

During the acceleration, the velocity has to be increased until the velocity limit V_MAX is reached or deceleration is required in order to exactly reach the target position. The TMC429 automatically determines the deceleration position in *ramp_mode* and decelerates. This calculation uses the difference between current position and target position and the proportionality parameter p , which has to be $p = 2048 / S$.

The following formula results:

$$p = \frac{2048}{\left(\frac{1}{2} \cdot 2048 \cdot \frac{256}{A_MAX}\right) \cdot 2^{RAMP_DIV - PULSE_DIV}}$$

This can be simplified to

$$p = \frac{A_MAX}{128 \cdot 2^{RAMP_DIV - PULSE_DIV}}$$

HINTS

- To avoid overshooting, the parameter $PMUL$ should be made approximately 1% smaller than calculated. Alternatively set p reduced by an amount of 1%.
- If the proportionality parameter p is too small, the target position will be reached slower, because the slow down ramp starts earlier. The target position is approached with minimal velocity V_MIN , whenever the internally calculated target velocity becomes less than V_MIN .
- With a good parameter p the minimal velocity V_MIN is reached a couple of steps before the target position.
- With parameter p set a little bit too large and a small V_MIN overshooting of one step (respectively one microstep) may occur. A decrement of the parameter $PMUL$ avoids this one-step overshooting.

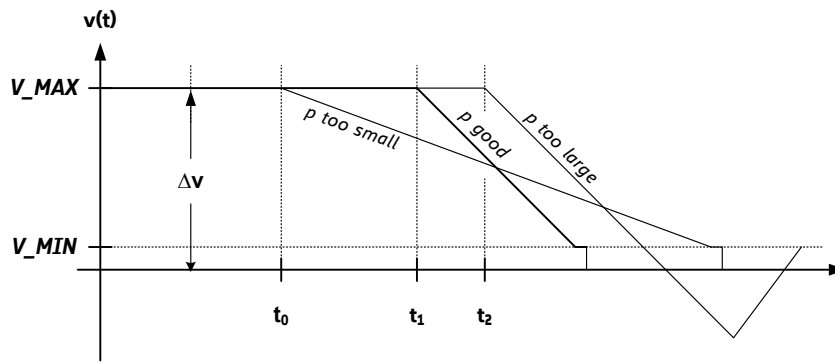

Figure 8.3 Proportionality parameter p and outline of velocity profile(s)

8.1.10.2.1 Choosing a Pair of $PMUL$ and $PDIV$

The calculation is based on the formula

$$p = \frac{P_{MUL}}{P_{DIV}} = \frac{PMUL}{2^{3+PDIV}}$$

CALCULATIONS

1. To represent the parameter p choose a pair of $PMUL$ and $PDIV$ which approximates p .
2. Value range for $PMUL$: 128... 255
3. Value range for $PDIV$: one out of {0, 1, 2, 3, 4, 5, 6, 7, 8, 9, 10, 11, 12, 13} (representing P_{DIV} one out of {8, 16, 32, 64, 128, 256, 512, 1024, 2048, 4096, 8192, 16384, 32786, 65536})
4. Try all $128 * 14 = 1792$ possible pairs of $PMUL$ and $PDIV$ with a program and choose a matching pair.
5. To find a pair, calculate for each pair of $PMUL$ and $PDIV$

$$p = \frac{A_{MAX}}{128 * 2^{RAMP_DIV - PULSE_DIV}} \quad \text{and}$$

$$p' = \frac{P_{MUL}}{P_{DIV}} = \frac{PMUL}{2^{3+PDIV}} \quad \text{and}$$

$$q = \frac{p'}{p}$$

6. Select one of the pairs satisfying the condition $0.95 < q < 1.0$. The value q interpreted as a function $q(a_{max}, ramp_div, pulse_div, pmul, pdiv)$ gives the *quality criterion* required.

Although $q = 1.0$ indicates that the chosen P_{MUL} and P_{DIV} perfectly represent the desired p factor for a given A_{MAX} , overshooting could result because of finite numerical precision. On the other hand in case of high resolution microstepping, overshooting of one microstep is negligible in most applications.

To avoid overshooting, use $P_{MUL}-1$ instead of the selected P_{MUL} or select a pair (P_{MUL}, P_{DIV}) with $q = 0.99$.

8.1.10.2.2 Optimized Calculation of $PMUL$ and $PDIV$

The calculation of the parameters $PMUL$ and $PDIV$ can be simplified using the expression

$$PMUL = p * 2^3 * 2^{PDIV} \quad \text{with} \quad p = \frac{A_{MAX}}{128 * 2^{RAMP_DIV - PULSE_DIV}}$$

To avoid overshooting, use

$$p_{reduced} = p * (1 - p_{reduction}[\%]) \quad \text{with} \quad p_{reduction} \text{ approximately } 1\%$$

This results in:

$$PMUL = p_{reduced} * 2^3 * 2^{PDIV} = 0.99 * p * 2^3 * 2^{PDIV}$$

$PMUL$ becomes a function of the parameter $PDIV$. To find a valid pair $\{PMUL, PDIV\}$ choose one out of 14 pairs for $PDIV = \{0, 1, 2, 3, \dots, 13\}$ with $PMUL$ within the valid range $128 \leq PMUL \leq 255$.

The C language example `pmulpdiv.c` can be found on www.trinamic.com. The source code can directly be copied from the PDF datasheet file.

8.1.10.2.3 Calculation Example: *PMUL* and *PDIV*

```

/* PROGRAM EXAMPLE 'pmlpdiv.c' : How to Calculate p_mul & p_div for the TMC429 */

#include <math.h>
#include <stdio.h>
#include <stdlib.h>
#include <string.h>

void CalcPMulPDiv(int a_max, int ramp_div, int pulse_div, float p_reduction,
                 int *p_mul, int *p_div, double *PIdeal, double *PBest, double *PRedu )
{
    int    pdiv, pmul, pm, pd ;
    double p_ideal, p_best, p, p_reduced;

    pm=-1; pd=-1; // -1 indicates : no valid pair found
    p_ideal = a_max / (pow(2, ramp_div-pulse_div)*128.0);
    p       = a_max / ( 128.0 * pow(2, ramp_div-pulse_div) );
    p_reduced = p * ( 1.0 - p_reduction );

    for (pdiv=0; pdiv<=13; pdiv++)
    {
        pmul = (int)(p_reduced * 8.0 * pow(2, pdiv)) - 128;

        if ( (0 <= pmul) && (pmul <= 127) )
        {
            pm = pmul + 128;
            pd = pdiv;
        }
    }

    *p_mul = pm;
    *p_div = pd;

    p_best = ((double)(pm)) / ((double)pow(2,pd+3));

    *PIdeal = p_ideal;
    *PBest  = p_best;
    *PRedu  = p_reduced;
}

int main(int argc, char **argv)
{
    int  a_max=0, ramp_div=0, pulse_div=0, p_mul, p_div,
        a_max_lower_limit=0, a_max_upper_limit=0;
    double pideal, pbest, predu;
    float  p_reduction=0.0;

    char **argp;

    if (argc>1)
    {
        while (argv++, argc--)
        {
            argp = argv + 1;   if (*argp==NULL) break;

            if ( (!strcmp(*argv, "-a")) ) sscanf(*argp, "%d", &a_max);
            else if ( (!strcmp(*argv, "-r")) ) sscanf(*argp, "%d", &ramp_div);
            else if ( (!strcmp(*argv, "-p")) ) sscanf(*argp, "%d", &pulse_div);
            else if ( (!strcmp(*argv, "-pr")) ) sscanf(*argp, "%f", &p_reduction);
        }
    }
    else
    {
        fprintf(stderr, "\n  USAGE : pmlpdiv -a <a_max> -r <ramp_div> -p <pulse_div> -pr <0.00 .. 0.10>\n"
            "        EXAMPLE : pmlpdiv -a 10 -r 3 -p 3 -pr 0.05\n");
        return 1;
    }

    printf("\n\n  a_max=%d\t ramp_div=%d\t pulse_div=%d\t p_reduction=%f\n\n",
        a_max, ramp_div, pulse_div, p_reduction);

    CalcPMulPDiv(a_max, ramp_div, pulse_div, p_reduction, &p_mul, &p_div, &pideal, &pbest, &predu );

    printf("  p_mul = %3.3d\n  p_div = %3d\n\n  p_ideal = %f\n  p_best = %f\n  p_redu = %f\n\n",
        p_mul, p_div, pideal, pbest, predu);

    a_max_lower_limit = (int)pow(2, (ramp_div-pulse_div-1));
    printf("\n  a_max_lower_limit = %d", a_max_lower_limit);
    if (a_max < a_max_lower_limit) printf(" [WARNING: a_max < a_max_lower_limit]");
    a_max_upper_limit = ((int)pow(2, (12+(ramp_div-pulse_div)))) -1;
    printf("\n  a_max_upper_limit = %d", a_max_upper_limit);
    if (a_max > a_max_upper_limit) printf(" [WARNING: a_max > a_max_upper_limit]");
    printf("\n\n");

    return 0;
}
/* ----- */

```

8.1.11 *lp*, *RAMP_MODE*, and *REF_CONF* (IDX=%1010)

The configuration words *REF_CONF* and *RAMP_MODE* are accessed via a common address.

| <i>lp</i> , <i>RAMP_MODE</i> , AND <i>REF_CONF</i> | |
|--|--|
| Bit or Register | Function |
| <i>RAMP_MODE</i> | The two bits <i>RAMP_MODE</i> (<i>R_M</i>) select one of the four possible stepping modes. |
| <i>lp</i> | The bit called <i>lp</i> (latched position) is a read only status bit. |
| <i>REF_CONF</i> | The configuration bits <i>REF_CONF</i> select the behavior of the reference switches. |

8.1.11.1 *RAMP_MODE* Register

| TMC429 MOTION MODES | | |
|-----------------------|----------------------|---|
| <i>RAMP_MODE</i> bits | Mode | Function |
| %00 | <i>ramp_mode</i> | Default mode for positioning applications with trapezoidal ramp. This mode is provided as default mode for positioning tasks. |
| %01 | <i>soft_mode</i> | Similar to <i>ramp_mode</i> , but with soft target position approaching. The target position is approached with exponentially reduced velocity. This feature can be useful for applications where vibrations at the target position have to be minimized. |
| %10 | <i>velocity_mode</i> | Mode for velocity control applications, change of velocities with linear ramps. This mode is for applications, where stepper motors have to be driven precisely with constant velocity. |
| %11 | <i>hold_mode</i> | The velocity is controlled by the microcontroller, motion parameter limits are ignored. This mode is provided for motion control applications, where the ramp generation is completely controlled by the microcontroller. |

8.1.11.2 The REF_CONF Register and the lp Read-Only Status Bit

A reference switch can be used as an automatic stop switch. The reference switch indicates the reference position within a given tolerance. The automatic stop function of the switches can be enabled or disabled. Also a reference tolerance range (see register *DX_REF_TOLERANCE*, chapter 8.1.14) can be programmed to allow motion within the reference switch active range during homing.

When a reference switch is triggered, the actual position can be stored automatically. This allows a precise determination of the reference point. It is initiated by writing a dummy value to the register *X_LATCHED* (see chapter 8.1.15). The read-only status bit *lp* (latch position waiting) indicates that the next change of the selected reference switch will trigger latching the position *X_ACTUAL*. The *lp* bit is automatically reset after position latching.

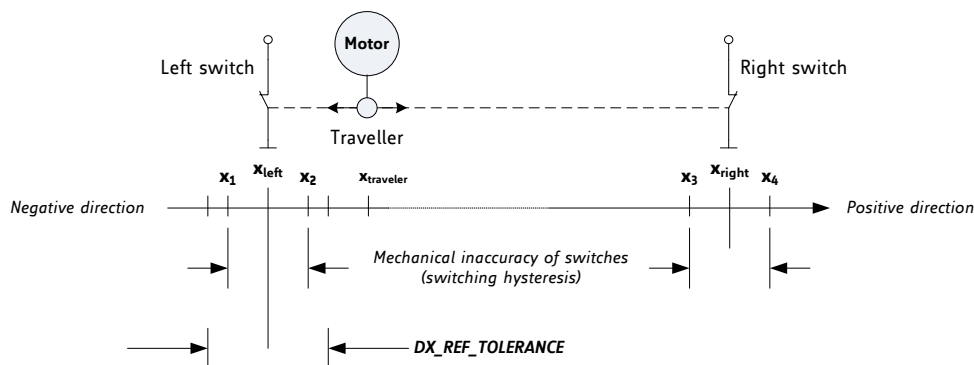

Figure 8.4 Left switch and right switch for reference search and automatic stop function

The bits contained in the *REF_CONF* register control the semantic and the actions of the reference/stop switch modes for interrupt generation as explained later. The stepper motor stops if the reference/stop switch becomes active. This mechanism reacts only to the switch which corresponds to the actual motion direction, e.g. the right switch when moving to a more positive position. The configuration bits named *disable_stop_l* respectively *disable_stop_r* disable these automatic stop functions. If the bit *soft_stop* is set, the motor stops with linear ramp as determined by *A_MAX*.

| REFERENCE SWITCH CONFIGURATION BITS <i>REF_CONF</i> AND <i>LP STATUS BIT</i> | |
|--|--|
| <i>REF_CONF</i> mnemonic | Function |
| <i>disable_stop_l</i> | 0 : The motor will be stopped when the velocity is negative ($V_ACTUAL < 0$) and the left reference switch becomes active. 1 : Left reference switch is disabled as an automatic stop switch. |
| <i>disable_stop_r</i> | 0 : Stops a motor if the velocity is positive ($V_ACTUAL > 0$) and the right reference switch becomes active. 1 : Right reference switch is disabled as an automatic stop switch. |
| <i>soft_stop</i> | 0 : Stopping takes place immediately; motion parameter limits are ignored. 1 : Stopping takes place in consideration of motion parameter limits; stops with linear ramp. |
| <i>ref_RnL</i> | The bit <i>ref_RnL</i> (<i>reference switch Right not Left</i>) defines which switch will be used as the reference switch. The definition of the reference switch by the configuration bit <i>ref_RnL</i> has no effect on the stop function of the reference switches if <i>disable_stop_l</i> = 0 respectively <i>disable_stop_r</i> = 0. 0 : The left reference switch controls reference switch functions. 1 : The right (not left) reference switch controls reference switch functions. |
| <i>lp</i> | 0 : This is the power-on default of the <i>lp</i> (latched position waiting) bit. 1 : <i>X_LATCHED</i> has been initialized by a write access to latch the position on a change of the reference switch. It is set to 0 after a position has been latched. |

8.1.12 INTERRUPT_MASK & INTERRUPT_FLAGS (IDX=%1011)

The TMC429 provides one interrupt register of eight flags for each stepper motor.

Interrupt bits are named *int_<mnemonic>*. The interrupt out nINT_SDO_C is set active low and the interrupt status bit *int* is set active high if at least one interrupt flag of one motor becomes set. If the interrupt status is inactive, nINT is high (1) and *int* is low (0).

SETTING MASKS AND FLAGS

- An interrupt flag is set to 1 if its assigned interrupt condition occurs.
- Each interrupt bit can either be enabled or disabled (1/0) individually by an associated interrupt mask bit named *mask_<mnemonic>*.
- Interrupt flags are reset to 0 by a write access (RW=0) to their interrupt register address (IDX=%1011). Write 1 at the position of the bit to clear the flag. Writing a 0 to the corresponding position leaves the interrupt flag untouched.
- Interrupt flags are forced to 0 if the corresponding mask bit is disabled (0).

| INTERRUPT FLAGS FOR EACH MOTOR | |
|--------------------------------|--|
| <i>int_<mnemonic></i> | Function |
| <i>int_pos_end</i> | If a target position is reached while the interrupt mask <i>mask_pos_end</i> is 1, the bit is set to 1. |
| <i>int_ref_wrong</i> | Reference switch signal was active outside the reference switch tolerance range (defined by the <i>DX_REF_TOLERANCE</i> register). The switches processed via the inputs REF1, REF2, REF3, REFR1, REFR2, and REFR3 can be used as stop switches for automatic motion limiting, as reference switches, and for both. If a reference switch becomes active out of the reference switch tolerance range the interrupt flag <i>int_ref_wrong</i> is set if the interrupt mask bit <i>mask_ref_wrong</i> is set. |
| <i>int_ref_miss</i> | The interrupt flag <i>int_ref_miss</i> is set if the reference switch is inactive at the 0 position and the mask <i>mask_ref_miss</i> is enabled. |
| <i>int_stop</i> | The <i>int_stop</i> flag is set, if the reference switch has forced a stop during motion and if the interrupt mask <i>mask_stop</i> is set. |
| <i>int_stop_left_low</i> | High to low transition of left reference switch. The <i>int_stop_left_low</i> flag is set if the reference switch changes from high to low and if the interrupt mask bit <i>mask_stop_left_low</i> is set. |
| <i>int_stop_right_low</i> | High to low transition of right reference switch. The <i>int_stop_right_low</i> flag is set if the reference switch changes from high to low and if the interrupt mask bit <i>mask_stop_right_low</i> is set. |
| <i>int_stop_left_high</i> | Low to high transition of left reference switch. The <i>int_stop_left_high</i> flag indicates that the left reference switch input changes from low to high if the mask bit <i>mask_stop_left_high</i> is set. |
| <i>int_stop_right_high</i> | Low to high transition of right reference switch. The <i>int_stop_right_high</i> flag indicates that the right reference switch input changes from low to high if the mask bit <i>mask_stop_right_high</i> is set. |

| INTERRUPT MASK BIT FOR EACH MOTOR | |
|-----------------------------------|------------------------------------|
| <i>mask_<mnemonic></i> | Function |
| <i>mask_pos_end</i> | 1: mask enabled; 0: mask disabled. |
| <i>mask_ref_wrong</i> | 1: mask enabled; 0: mask disabled. |
| <i>mask_ref_miss</i> | 1: mask enabled; 0: mask disabled. |
| <i>mask_stop</i> | 1: mask enabled; 0: mask disabled. |
| <i>mask_stop_left_low</i> | 1: mask enabled; 0: mask disabled. |
| <i>mask_stop_right_low</i> | 1: mask enabled; 0: mask disabled. |
| <i>mask_stop_left_high</i> | 1: mask enabled; 0: mask disabled. |
| <i>mask_stop_right_high</i> | 1: mask enabled; 0: mask disabled. |

The full step frequency R_{FS} in Step/Dir mode is given by

$$R_{FS}[Hz] = \frac{R[Hz]}{\#microsteps\ of\ external\ driver}$$

The full step frequency R_{FS} in SPI mode is given by

$$R_{FS}[Hz] = \frac{R[Hz]}{2^{USRS}}$$

The change ΔR in the pulse rate per time unit is given by

$$\Delta R[Hz/s] = \frac{f_{CLK}[Hz] * f_{CLK}[Hz] * A_MAX}{2^{PULSE_DIV+RAMP_DIV+29}}$$

where

- ΔR : pulse frequency change per second (acceleration)
- 29: the constant is derived from $2^{29} = 2^5 * 2^5 * 2^8 * 2^{11} = 32*32*256*2048$.
- 32 comes from fixed clock pre-dividers,
- 256 comes from the velocity accumulation clock pre-divider, and
- 2048 comes from the velocity accumulation clock divider programmed by A_MAX . The parameter A_MAX is in range 0 to 2047.

The change of fullstep frequency ΔR_{FS} in the pulse rate per time unit in *Step/Dir mode* is given by

$$\Delta R_{FS}[Hz] = \frac{\Delta R[Hz]}{\#microsteps\ of\ external\ driver}$$

The change of fullstep frequency ΔR_{FS} in the pulse rate per time unit in *SPI mode* is given by

$$\Delta R_{FS}[Hz] = \frac{\Delta R[Hz]}{2^{USRS}}$$

The angular velocity of a stepper motor can be calculated based on the full step frequency $R_{FS}[Hz]$ for a given number of full steps per rotation. Similarly, the angular acceleration of a stepper motor can be calculated based on the change of the full step frequency per second $\Delta R_{FS}[Hz]$.

8.1.13.2 Calculating the Number of Steps during Linear Acceleration

$$S = \frac{1}{2} * \frac{v^2}{a}$$

where

- S = number of steps
- a = linear acceleration
- v = velocity

With $v = R[Hz]$ and $a = \Delta R[Hz/s]$ one gets:

$$S = \frac{1}{2} * \frac{v^2}{A_MAX} * \frac{2^{RAMP_DIV}}{2^{PULSE_DIV}} \div 2^3$$

The number of full steps S_{FS} in Step/Dir mode during linear acceleration is given by

$$S_{FS} = \frac{S}{\#microsteps\ of\ external\ driver}$$

The number of full steps S_{FS} in SPI mode during linear acceleration is given by

$$S_{FS} = \frac{S}{2^{usrs}}$$

Changing $PULSE_DIV$ in *velocity_mode* or in *hold_mode* might force an internal microstep (with microstep resolution defined by $usrs$) depending on the actual microstep position. This behavior can be observed especially when the motor is at rest. In *ramp_mode* this does not occur. $PULSE_DIV$ should only be changed in *ramp_mode*!

8.1.13.3 Choosing the Microstep Resolution in SPI Mode

The three bit wide parameter *USRS* determine the microstep resolution for an associated stepper motor. There is an individual set of 6 DAC bits provided for each of the two phases (coils) of each motor. These two six bit values control the SPI driver coil currents. With 6 bit DAC resolution, the TMC429 can provide up to 64 microsteps per full step. With 4 bits, fewer positions can be determined, but still an improvement can be experienced when choosing more than 16 microsteps resolution. Depending on the microstep resolution, a subset of the 6 DAC bits is significant. The motors also can be operated in fullstep. For fullstepping, the current amplitude is constant for both phases of a stepper motor and the polarity of one phase changes with each full step.

The microstep counters are initialized to 0 during power-on reset. With each microstep an associated counter accumulates the programmed microstep resolution value *USRS*.

| MICROSTEP RESOLUTION SELECTION (<i>USRS</i>) PARAMETER | | | | | | |
|--|---|---|--------------------------|---|--|--|
| <i>USRS</i> | | | [Microsteps / full step] | Significant DAC Bits (controlling current amplitude) | Comment | |
| 0 | 0 | 0 | 1 | - | full step (constant current amplitude) | |
| 0 | 0 | 1 | 2 | 5 (MSB) | half step | |
| 0 | 1 | 0 | 4 | 5 (MSB), 4 | microstepping | |
| 0 | 1 | 1 | 8 | 5 (MSB), 4, 3 | | |
| 1 | 0 | 0 | 16 | 5 (MSB), 4, 3, 2 | | |
| 1 | 0 | 1 | 32 | 5 (MSB), 4, 3, 2, 1 | | |
| 1 | 1 | 0 | 64 | 5 (MSB), 4, 3, 2, 1, 0 (LSB) | | |
| 1 | 1 | 1 | | | | |

8.1.14 *DX_REF_TOLERANCE* (IDX=%1101)

Generally, the switch inputs REF1, REF2, REF3, REFR1, REFR2, and REFR3 can be used as stop switches for automatic motion limiting and as reference switches defining a reference position for the stepper motor. To allow the motor to drive near the reference point, it is possible to exclude a motion range of steps from the stop switch function.

The parameter *DX_REF_TOLERANCE* disables automatic stopping by a switch around the origin (see Figure 8.4). To use the *DX_REF_TOLERANCE* far from the origin, the actual position has to be adapted, e.g. by setting it to zero in the center of the tolerance range. Additionally, the parameter *DX_REF_TOLERANCE* affects interrupt conditions as described before (section 8.1.12).

8.1.15 *X_LATCHED* (IDX=%1110)

This read-only register stores the actual position *X_ACTUAL* upon a change of the reference switch state. The reference switch is defined by the bit *ref_RnL* of the configuration register 8.2.4.5. Writing a dummy value to the (read-only) register *X_LATCHED* initializes the position storage mechanism. The actual position is saved with the next rising edge or falling edge signal of the reference switch depending on the actual motion direction of the stepper motor. The actual position is latched when the switch defined as the reference switch by the *ref_RnL* bit changes (see chapter 1.5.4). The status bit *lp* signals, if latching of a position is pending. This way, a precise reference is available for homing.

An event at the reference switch associated to the actual motion direction takes effect only during motion (when *V_ACTUAL* ≠ 0).

8.1.16 *USTEP_COUNT_429* (IDX=%1111)

The read only register *USTEP_COUNT_429* holds the actual microstep pointer. This register is intended for applications where the motion controller part is completely switched off for power saving and the motor needs to be initialized to the same position after re-switching power on.

Reading the *USTEP_COUNT_429* allows reading the actual sequencer position of the internal sequencer. This is useful to support a system power down of an SPI driver based system without position loss: Store the position counter and the microstep counter *USTEP_COUNT_429* before power down. After power up, set actual and target position to a value equal to the stored target position minus the stored microstep counter. Then, move to the stored target position. The target position and electrical position now match the values before power down. Afterwards, you can enable the stepper motor driver.

8.2 Global Parameter Registers

The registers addressed by RRS=0 with SMDA=%11 are global common parameter registers. To emphasize this difference, the address label JDX is used as index name instead of IDX (see overview in chapter 7.3).

OVERVIEW GLOBAL PARAMETER REGISTER MAPPING

| REGISTER | DESCRIPTION |
|--|---|
| <i>DATAGRAM_LOW_WORD</i> <i>DATAGRAM_HIGH_WORD</i> | The registers are used to store datagrams sent back from the stepper motor driver chain. |
| <i>cdgw</i> | The status bit signals an update of <i>DATAGRAM_LOW_WORD</i> and <i>DATAGRAM_HIGH_WORD</i> . |
| <i>COVER_DATAGRAM</i> | The TMC429 provides for directly sending datagrams from the microcontroller to the stepper motor drivers. A datagram can be transferred to the stepper motor driver by partially covering one datagram sent to the driver chain. |
| <i>COVER_POS</i> <i>COVER_LEN</i> | The parameter <i>COVER_POS</i> defines the position of the first datagram bit to be covered by the <i>COVER_DATAGRAM</i> (JDX=%0011). The number of bits to be covered is defined by <i>COVER_LEN</i> . |
| <i>IF_CONFIGURATION_429</i> | This register is used for configuration of <ul style="list-style-type: none"> - the reference switch inputs - the de-multiplexed interrupt output - the Step/Dir interface - the association of the position compare output signal to one stepper motor |
| <i>STEPPER MOTOR</i> <i>GLOBAL PARAMETER</i> <i>REGISTER</i> | This register holds different configuration bits for the stepper motor driver chain and defines <ul style="list-style-type: none"> - polarities and chip select signal (SPI) - timing (SPI mode / Step/Dir mode) - number of stepper motor drivers in the chain (SPI) - updates (SPI) - multiplexing reference switch inputs (TMC429-I and TMC429-PI24) - reference switch adjustments (TMC429-I) |

8.2.1 DATAGRAM_LOW_WORD (IDX=%0000) & DATAGRAM_HIGH_WORD (IDX=%0001)

The TMC429 stores datagrams sent back from the stepper motor driver chain with a total length of up to 48 bits. The two registers *DATAGRAM_LOW_WORD* and *DATAGRAM_HIGH_WORD* form a 48 bit shift register in which

DATAGRAM_LOW_WORD holds the lower 24 bits and
DATAGRAM_HIGH_WORD holds the higher 24 bits.

The data from the pin *SDI_S* is shifted left into the register with each datagram bit sent to the stepper motor driver chain via the signal *SDO_S*. A write to one of these read-only registers initializes them, to update their contents with the next datagram received from the driver chain.

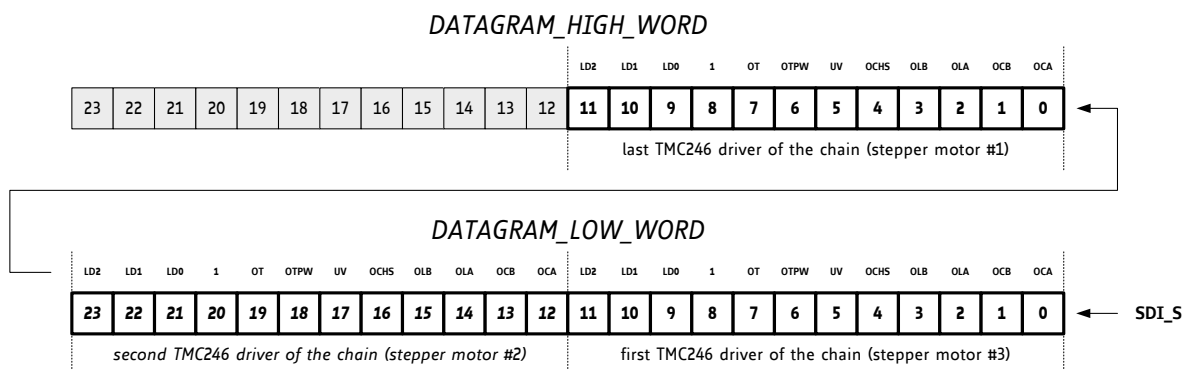

Figure 8.5 Example of status bit mapping for a chain of three TMC246 or TMC249

8.2.1.1 Functionality of the *cdgw* Status Bit

The *cdgw* (= *cover datagram waiting*; see section 8.2.3) status bit is set to 1 until a datagram is received from the stepper motor driver chain. In order to read out the *DATAGRAM_LOW_WORD* and the *DATAGRAM_HIGH_WORD* the *cdgw* status bit is needed to detect a complete datagram transfer after an initial write to one of the two registers. The fact that the *cdgw* is formed by a logical OR between the *cover datagram* status and the status of the *DATAGRAM_LOW_WORD* and *DATAGRAM_HIGH_WORD* does not cause any restriction concerning its usage. This is because a write to the *COVER_DATAGRAM* register forces sending a datagram which results in an update of the *DATAGRAM_LOW_WORD* and *DATAGRAM_HIGH_WORD* registers.

If the *COVER_DATAGRAM* mechanism is not used, the *cdgw* status bit is exclusively available as status signal of *DATAGRAM_LOW_WORD* and *DATAGRAM_HIGH_WORD*.

8.2.2 COVER_POS & COVER_LEN (IDX=%0010)

The TMC429 allows for directly sending datagrams to the stepper motor drivers. This is important for initialization purpose when using drivers which require a configuration prior to operation, like the TMC262 in SPI mode. Also during operation, datagrams may be required to change the driver mode of operation. A datagram with up to 24 bits can be transferred to the stepper motor driver by covering one datagram sent to the driver chain. The parameter *COVER_POS* defines the position of the first datagram bit to be covered by the *COVER_DATAGRAM* (IDX=%0011) of length *COVER_LEN*. In contrast to the datagram numbering order of bits, the position count for the cover datagram starts with 0. The *COVER_DATAGRAM* bits indexed from *cover_len-1* to 0 cover the datagram sent to the driver chain.

A step bit used to control stepper motor drivers must not be covered while a motor is running! The reason is that the coverage of a step bit causes losing the associated step if the step bit is active.

WRITE ACCESS VERSUS READ ACCESS

The TMC429 stores *COVER_POS+1* instead of *COVER_POS* due to internal requirements. So, one writes *COVER_POS* but reads back *COVER_POS+1*. The *cdgw* (= *cover waiting*) bit is available by read out of this register and indicates that the cover datagram has not been sent yet.

CDGW VERSUS CW

The *cdgw* status bit (see section 8.2.3) is the result of a logical OR between *cdw* and an internal signal that indicates the status of the stepper motor serial driver chain send register.

8.2.3 COVER_DATAGRAM (IDX=%0011)

The TMC429 provides direct sending of datagrams from the microcontroller to the stepper motor drivers. A datagram can be transferred to the stepper motor driver by covering one datagram sent to the driver chain. The register *COVER_DATAGRAM* holds up to 24 bit. A cover datagram covers the next datagram sent to the stepper motor driver chain. If no datagrams are sent to the driver chain, the cover datagram is sent immediately after writing it into the *COVER_DATAGRAM* register.

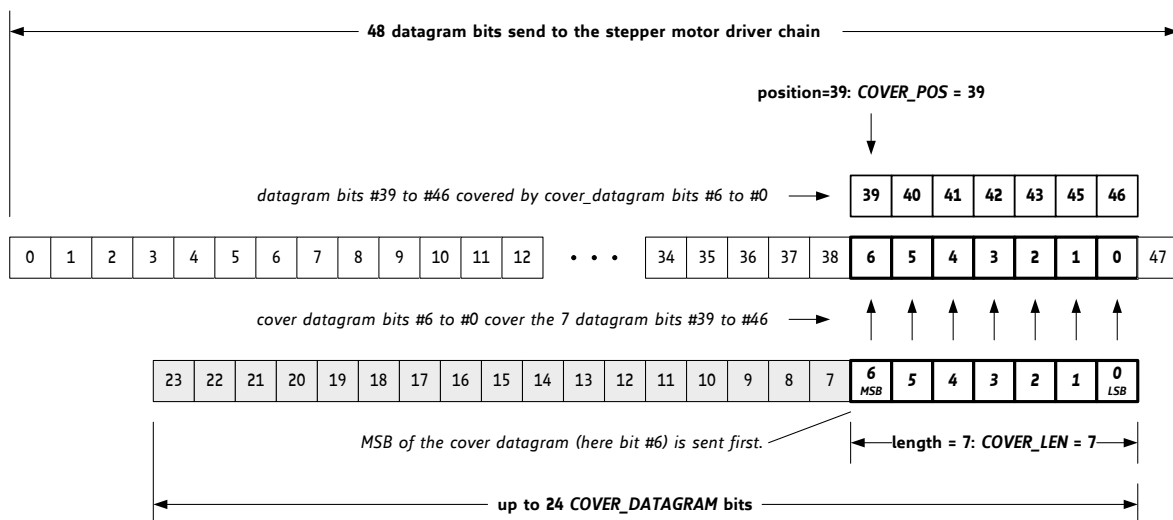

Figure 8.6 Cover datagram example with 7 bits covering 7 bits of a 48 bit datagram

The *cdgw* status bit has to be checked to be sure that no cover datagram is waiting to be processed. After that, a new cover datagram can be written into the *COVER_DATAGRAM* register. The *cdgw* bit is set to 1 until the *COVER_DATAGRAM* is sent.

The *cdgw* status bit is also used as status bit for the *DATAGRAM_LOW_WORD* and *DATAGRAM_HIGH_WORD* (see section 0).

8.2.4 IF_CONFIGURATION_429 (IDX=%0100)

The register *IF_CONFIGURATION_429* is the interface configuration register for the TMC429. It is used for configuration of

- the additional reference inputs,
- the de-multiplexed interrupt output,
- the Step/Dir interface, and
- the association of the position compare output signal to one stepper motor.

| INTERFACE CONFIGURATION REGISTER CONTROL BITS | | | | | | | |
|---|--|-----|---------|-----|---------|-----|---------|
| <i>IF_CONFIGURATION_429</i> | Function | | | | | | |
| <i>inv_ref</i> | Invert common polarity for all reference switches. If this bit is set, a low level on the input signals an active reference switch. | | | | | | |
| <i>sdo_int</i> | Map internal non-multiplexed interrupt status to nINT_SDO_C (needs SDOZ_C as SDO_C for read back information from the TMC429 to the microcontroller). With SDO_INT=1 the nINT_SDO_C is a non-multiplexed nINT output to the microcontroller | | | | | | |
| <i>step_half</i> | Toggle on each step pulse (this halves the step frequency, both pulse edges represent steps). <i>step_half</i> reduces the required step pulse bandwidth and is useful if for low-bandwidth optocouplers. <i>This function can be used for the TMC262 stepper driver.</i> | | | | | | |
| <i>inv_stp</i> | Invert step pulse polarity. This configuration can be used for adaption of the step polarity to external driver stages. | | | | | | |
| <i>inv_dir</i> | Invert dir signal polarity. This is for adaption to external driver stages. Alternatively, this can be used as a shaft bit to adjust the direction of motion for a motor, but do not use this as a direction bit because it has no effect on the internal handling of signs (<i>X_ACTUAL</i> , <i>V_ACTUAL</i> ...). | | | | | | |
| <i>en_sd</i> | Enable Step/Dir. This bit switches the driver to Step/Dir mode. If this flag is 0, it operates in SPI mode. <i>Note: The step pulse timing (length) must be compatible with both, the desired step frequency and the external drivers' requirements. The step pulse timing is determined by the 4 LSBs of CLK2_DIV when Step/Dir mode is selected by EN_SD=1.</i> | | | | | | |
| <i>pos_comp_sel</i> | Select one motor out of three motors for the position compare function output of the TMC429 named POSCMP. <table border="1" style="margin-left: 20px;"> <tr> <td>%00</td> <td>Motor 1</td> </tr> <tr> <td>%01</td> <td>Motor 2</td> </tr> <tr> <td>%10</td> <td>Motor 3</td> </tr> </table> | %00 | Motor 1 | %01 | Motor 2 | %10 | Motor 3 |
| %00 | Motor 1 | | | | | | |
| %01 | Motor 2 | | | | | | |
| %10 | Motor 3 | | | | | | |
| <i>en_refr</i> | Enable TMC429 reference inputs REFR1, REFR2, REFR3. As a default, the right reference inputs are disabled (EN_REFR=0). | | | | | | |

| 32 BIT DATAGRAM SENT FROM A μ C TO THE TMC429 | | | | | | | | | | | | | | | | | | | | | | | | | | | | | | | | |
|---|---|---------|---|---|---|----|---|----|------|---|---|---|---|---|---|---|---|---|---|---|---|---|---|---|---|---|---|---|---|---|---|--|
| 3 | 3 | 2 | 2 | 2 | 2 | 2 | 2 | 2 | 2 | 2 | 2 | 1 | 1 | 1 | 1 | 1 | 1 | 1 | 1 | 1 | 1 | 9 | 8 | 7 | 6 | 5 | 4 | 3 | 2 | 1 | 0 | |
| 1 | 0 | 9 | 8 | 7 | 6 | 5 | 4 | 3 | 2 | 1 | 0 | 9 | 8 | 7 | 6 | 5 | 4 | 3 | 2 | 1 | 0 | | | | | | | | | | | |
| RRS | | ADDRESS | | | | | | RW | DATA | | | | | | | | | | | | | | | | | | | | | | | |
| | | SMDA | 0 | 1 | 0 | 0 | | | | | | | | | | | | | | | | | | | | | | | | | | |
| 0 | | | | | | | | | | | | | | | | | | | | | | | | | | | | | | | | |
| | | | | | | | | | | | | | | | | | | | | | | | | | | | | | | | | |
| | | | | | | | | | | | | | | | | | | | | | | | | | | | | | | | | |
| | | | | | | | | | | | | | | | | | | | | | | | | | | | | | | | | |
| | | | | | | | | | | | | | | | | | | | | | | | | | | | | | | | | |
| | | | | | | | | | | | | | | | | | | | | | | | | | | | | | | | | |
| | | | | | | | | | | | | | | | | | | | | | | | | | | | | | | | | |
| | | | | | | | | | | | | | | | | | | | | | | | | | | | | | | | | |
| | | | | | | | | | | | | | | | | | | | | | | | | | | | | | | | | |
| | | | | | | | | | | | | | | | | | | | | | | | | | | | | | | | | |
| | | | | | | | | | | | | | | | | | | | | | | | | | | | | | | | | |
| | | | | | | | | | | | | | | | | | | | | | | | | | | | | | | | | |
| | | | | | | | | | | | | | | | | | | | | | | | | | | | | | | | | |
| | | | | | | | | | | | | | | | | | | | | | | | | | | | | | | | | |
| | | | | | | | | | | | | | | | | | | | | | | | | | | | | | | | | |
| | | | | | | | | | | | | | | | | | | | | | | | | | | | | | | | | |
| | | | | | | | | | | | | | | | | | | | | | | | | | | | | | | | | |
| | | | | | | | | | | | | | | | | | | | | | | | | | | | | | | | | |
| | | | | | | | | | | | | | | | | | | | | | | | | | | | | | | | | |
| | | | | | | | | | | | | | | | | | | | | | | | | | | | | | | | | |
| | | | | | | | | | | | | | | | | | | | | | | | | | | | | | | | | |
| | | | | | | | | | | | | | | | | | | | | | | | | | | | | | | | | |
| | | | | | | | | | | | | | | | | | | | | | | | | | | | | | | | | |
| | | | | | | | | | | | | | | | | | | | | | | | | | | | | | | | | |
| | | | | | | | | | | | | | | | | | | | | | | | | | | | | | | | | |
| | | | | | | | | | | | | | | | | | | | | | | | | | | | | | | | | |
| | | | | | | | | | | | | | | | | | | | | | | | | | | | | | | | | |
| | | | | | | | | | | | | | | | | | | | | | | | | | | | | | | | | |
| | | | | | | | | | | | | | | | | | | | | | | | | | | | | | | | | |
| | | | | | | | | | | | | | | | | | | | | | | | | | | | | | | | | |
| | | | | | | | | | | | | | | | | | | | | | | | | | | | | | | | | |
| | | | | | | | | | | | | | | | | | | | | | | | | | | | | | | | | |
| | | | | | | | | | | | | | | | | | | | | | | | | | | | | | | | | |
| | | | | | | | | | | | | | | | | | | | | | | | | | | | | | | | | |
| | | | | | | | | | | | | | | | | | | | | | | | | | | | | | | | | |
| | | | | | | | | | | | | | | | | | | | | | | | | | | | | | | | | |
| | | | | | | | | | | | | | | | | | | | | | | | | | | | | | | | | |
| | | | | | | | | | | | | | | | | | | | | | | | | | | | | | | | | |
| | | | | | | | | | | | | | | | | | | | | | | | | | | | | | | | | |
| | | | | | | | | | | | | | | | | | | | | | | | | | | | | | | | | |
| | | | | | | | | | | | | | | | | | | | | | | | | | | | | | | | | |
| | | | | | | | | | | | | | | | | | | | | | | | | | | | | | | | | |
| | | | | | | | | | | | | | | | | | | | | | | | | | | | | | | | | |
| | | | | | | | | | | | | | | | | | | | | | | | | | | | | | | | | |
| | | | | | | | | | | | | | | | | | | | | | | | | | | | | | | | | |
| | | | | | | | | | | | | | | | | | | | | | | | | | | | | | | | | |
| | | | | | | | | | | | | | | | | | | | | | | | | | | | | | | | | |
| | | | | | | | | | | | | | | | | | | | | | | | | | | | | | | | | |
| | | | | | | | | | | | | | | | | | | | | | | | | | | | | | | | | |
| | | | | | | | | | | | | | | | | | | | | | | | | | | | | | | | | |
| | | | | | | | | | | | | | | | | | | | | | | | | | | | | | | | | |
| | | | | | | | | | | | | | | | | | | | | | | | | | | | | | | | | |
| | | | | | | | | | | | | | | | | | | | | | | | | | | | | | | | | |
| | | | | | | | | | | | | | | | | | | | | | | | | | | | | | | | | |
| | | | | | | | | | | | | | | | | | | | | | | | | | | | | | | | | |
| | | | | | | | | | | | | | | | | | | | | | | | | | | | | | | | | |
| | | | | | | | | | | | | | | | | | | | | | | | | | | | | | | | | |
| | | | | | | | | | | | | | | | | | | | | | | | | | | | | | | | | |
| | | | | | | | | | | | | | | | | | | | | | | | | | | | | | | | | |
| | | | | | | | | | | | | | | | | | | | | | | | | | | | | | | | | |
| | | | | | | | | | | | | | | | | | | | | | | | | | | | | | | | | |
| | | | | | | | | | | | | | | | | | | | | | | | | | | | | | | | | |
| | | | | | | | | | | | | | | | | | | | | | | | | | | | | | | | | |
| | | | | | | | | | | | | | | | | | | | | | | | | | | | | | | | | |
| | | | | | | | | | | | | | | | | | | | | | | | | | | | | | | | | |
| | | | | | | | | | | | | | | | | | | | | | | | | | | | | | | | | |
| | | | | | | | | | | | | | | | | | | | | | | | | | | | | | | | | |
| | | | | | | | | | | | | | | | | | | | | | | | | | | | | | | | | |
| | | | | | | | | | | | | | | | | | | | | | | | | | | | | | | | | |
| | | | | | | | | | | | | | | | | | | | | | | | | | | | | | | | | |
| | | | | | | | | | | | | | | | | | | | | | | | | | | | | | | | | |
| | | | | | | | | | | | | | | | | | | | | | | | | | | | | | | | | |
| | | | | | | | | | | | | | | | | | | | | | | | | | | | | | | | | |
| | | | | | | | | | | | | | | | | | | | | | | | | | | | | | | | | |
| | | | | | | | | | | | | | | | | | | | | | | | | | | | | | | | | |
| | | | | | | </ | | | | | | | | | | | | | | | | | | | | | | | | | | |

NOTE

- After power-on, the TMC429 is in SPI mode. The output signals are logic high until they become configured for step/direction mode.
- Open inputs REFR1, REFR2, and REFR3 in Step/Dir mode have active state if REFMUX=0 due to their internal pull-up resistors. If EN_REFR=0 these additional reference switch inputs are ignored.
- REFMUX does not work in Step/Dir mode because the SPI signal nSCS_S is not available. The output is signal S2 (step2) in Step/Dir mode
- Do not enable unused REFR1, REFR2, REFR3 inputs of the TMC429 as STOP switches if these inputs are open!

8.2.4.1 POS_COMP_429 (IDX=%0101)

POS_COMP_429 defines a position, which becomes compared to the selected motor position (select via *pos_comp_sel*). Whenever the positions match, the *POS_COMP* output becomes active.

8.2.4.2 POS_COMP_INT_429 (IDX=%0110)

The position compare interrupt mask (*M*) and interrupt flag (*I*) register hold the mask and interrupt concerning the position compare function of the TMC429.

8.2.4.3 POWER_DOWN (IDX=%1000)

A write to the register address *POWER_DOWN* sets the TMC429 into the *power down mode* until it detects a falling edge at the pin *nSCS_C*. During power down, all internal clocks are stopped. All outputs remain stable, and all register contents are preserved.

8.2.4.4 TYPE_AND_VERSION_429 (IDX=%1001)

Read only register that gives type and version of the design. For the TMC429 version 1.01 it reads 0x429101.

8.2.4.5 REFERENCE_SWITCHES l3, r3, l2, r2, l1, and r1 (IDX=%1110)

The current state of the reference switches can be read out with this register. The TMC429-LI, TMC429-PI24, and the TMC429-I require different settings of related bits and registers before a read-out of the reference switch bits is possible.

| OVERVIEW: REASONABLE SETTINGS FOR DIFFERENT PACKAGES | | | | | | | | | | | | | | | | | | | | | | | |
|--|--------------|----------------|------------------|----|----|----|----|----|------------------|----|----|----|----|------------------|------------------|----|----|----|----|----|---|---|---|
| <i>refmux</i> | <i>mot1r</i> | <i>en_refr</i> | TMC429-I | | | | | | TMC429-PI24 | | | | | | TMC429-LI | | | | | | | | |
| | | | 1l | 1r | 2l | 2r | 3l | 3r | 1l | 1r | 2l | 2r | 3l | 3r | 1l | 1r | 2l | 2r | 3l | 3r | | | |
| 0 | 0 | 0 | x | - | x | - | x | - | x | - | x | - | x | - | x | - | x | - | x | - | x | - | |
| 0 | 0 | 1 | <i>don't use</i> | | | | | | x | x | x | x | x | *1 | x | x | x | x | x | x | x | x | x |
| 0 | 1 | 0 | x | x | x | - | - | - | <i>don't use</i> | | | | | | <i>don't use</i> | | | | | | | | |
| 1 | 0 | 0 | x | x | x | x | x | x | x | x | x | x | x | <i>don't use</i> | | | | | | | | | |

*1 always reads as high level (internal pull-ups)

If it is desired to invert the polarity of the reference switches, the bit *inv_ref* of the *IF_CONFIGURATION_429* register can be set. This allows matching normally open contacts or normally closed contacts.

TMC429-LI

To enable right reference switch inputs (REFR1, REFR2 and REFR3) and the associated status bits *r1*, *r2*, and *r3* for the right switches set *en_refr* of the register *IF_CONFIGURATION_429* to 1 (refer to chapter 0). With the default value *en_refr*=0 the right reference inputs REFR1, REFR2, and REFR3 are disabled and shown as inactive.

TMC429-PI24

To enable right reference switch inputs (REFR1, REFR2) and the associated status bits *r1* and *r2* for the right switches set *en_refr* of the register *IF_CONFIGURATION_429* to 1 (refer to chapter 0). With the default value *en_refr*=0 the right reference inputs REFR1 and REFR2 are disabled and shown as inactive.

If a right reference switch for the third motor is needed and SPI motor drivers are used, the *refmux* bit of the *STEPPER MOTOR GLOBAL PARAMETER CONTROL* can be set to 1 (refer to chapter 0).

Note: the *refmux* bit is only used for multiplexing reference switch inputs by using a 74HC157 multiplexer. Related to the TMC429-PI24 this is only required for getting a third right reference switch input. The bit *continuous_update* of the *STEPPER MOTOR GLOBAL PARAMETER REGISTER* (IDX=%1111) is important for reading out the reference switches if the external multiplexer is used.

TMC429-I

With the default value 0 of the bit *en_refr* (see *IF_CONFIGURATION_429*, chapter 8.2.4) all three right reference switch inputs of the TMC429-I are inactive, because the inputs are not available on the package. There are different possibilities for configuration and multiplexing of the three reference switch inputs. In chapter 8.2.4.5 they are explained in detail.

If all six reference switches are used in an SPI stepper motor driver chain (via an external 74HC157 multiplexer), these inputs are de-multiplexed internally by the TMC429-I. The states of the switches can be read out from the *REFERENCE_SWITCHES* read-only register. The bit *continuous_update* of the *STEPPER MOTOR GLOBAL PARAMETER REGISTER* (IDX=%1111) is important for reading out the reference switches if SPI drivers and the external multiplexer are used.

8.2.5.1 POLARITIES

The global parameter register *POLARITIES* is only used with SPI motor drivers and defines all polarities necessary.

| POLARITIES - GLOBAL PARAMETER REGISTER | | | | |
|---|---|---|---|---|
| POLARITIES (6 bits) | Function | | | |
| <i>polarity_nscs_s</i> | Controls the polarity of the selection signal nSCS_S for the stepper motor driver chain. | | | |
| | <table border="0"> <tr> <td>0</td> <td>The nSCS_S signal is low active.</td> </tr> <tr> <td>1</td> <td>The nSCS_S signal it is high active.</td> </tr> </table> | 0 | The nSCS_S signal is low active. | 1 |
| 0 | The nSCS_S signal is low active. | | | |
| 1 | The nSCS_S signal it is high active. | | | |
| <i>polarity_sck_s</i> | Defines the polarity of the stepper motor driver chain clock signal SCK_S. | | | |
| | <table border="0"> <tr> <td>0</td> <td>The clock polarity is according to Figure 11.1.</td> </tr> <tr> <td>1</td> <td>The clock signal SCK_S is inverted.</td> </tr> </table> | 0 | The clock polarity is according to Figure 11.1. | 1 |
| 0 | The clock polarity is according to Figure 11.1. | | | |
| 1 | The clock signal SCK_S is inverted. | | | |
| <i>polarity_ph_ab</i> | Defines the polarity of the phase bits for the stepper motor. | | | |
| | <table border="0"> <tr> <td>0</td> <td>Normal polarity.</td> </tr> <tr> <td>1</td> <td>Polarity inverted.</td> </tr> </table> | 0 | Normal polarity. | 1 |
| 0 | Normal polarity. | | | |
| 1 | Polarity inverted. | | | |
| <i>polarity_fd</i> | Defines the polarity of the fast decay controlling bit. | | | |
| | <table border="0"> <tr> <td>0</td> <td>Fast decay is high active.</td> </tr> <tr> <td>1</td> <td>Fast decay is low active.</td> </tr> </table> | 0 | Fast decay is high active. | 1 |
| 0 | Fast decay is high active. | | | |
| 1 | Fast decay is low active. | | | |
| <i>polarity_dac_ab</i> | Defines the polarity of the DAC bit vectors. | | | |
| | <table border="0"> <tr> <td>0</td> <td>The DAC bits are high active (normal polarity).</td> </tr> <tr> <td>1</td> <td>The DAC bits are inverted (low active).</td> </tr> </table> | 0 | The DAC bits are high active (normal polarity). | 1 |
| 0 | The DAC bits are high active (normal polarity). | | | |
| 1 | The DAC bits are inverted (low active). | | | |

8.2.5.2 csCommonIndividual

| CSCOMMONINDIVIDUAL - GLOBAL PARAMETER REGISTER | |
|---|--|
| <i>csComInd</i> | <p>Defines either if a single chip select signal nSCS_S is used in common for all stepper motor driver chips (e.g. for TMC236, TMC239, TMC246, TMC249) or if three chip select signals nSCS_S, nSCS2, nSCS3 are used to select the stepper motor driver chips individually.</p> <p>This feature is useful only for the TMC429 within the larger packages, where the two additional chip select signals (nSCS2, nSCS3) are available.</p> <p>The common chip select signal nSCS_S is used if <i>csCommonIndividual</i>=0.</p> <p>The polarity control bit for the nSCS_S signal must be set to <i>polarity_nscs_s</i>=0 if <i>csCommonIndividual</i>=1.</p> <p>The chip select polarity is always negative for three individual chips select signals.</p> |

8.2.5.3 CLK2_DIV

The eight *CLK2_DIV* bits determine the clock frequency of the motor driver chain in SPI mode. (For information about timing in Step/Dir mode refer to chapter 10.)

UNIT

The range of *CLK2_DIV* is {7, 8, 9, ... 253, 254, 255}.

- The default value after power-on reset is *CLK2_DIV* = 15.
- A value of 7 (%00000111, \$07) is the lower limit for the clock divider parameter. With *CLK2_DIV* = 7 the clock frequency of SCK_S is at maximum. This value is best for the TRINAMIC drivers TMC236 / TMC239 / TMC246 / TMC249.
- The frequency f_{SCK_S} [Hz] of SCK_S does not become higher for *CLK2_DIV* < 7, but the signal SCK_S becomes asymmetric with respect to its duty cycle. An asymmetric duty cycle may cause instable SPI transmission to stepper drivers, because the timing might become too fast.
- A value of 255 (%11111111, \$FF) is the upper limit for the parameter *CLK2_DIV*. With *CLK2_DIV* = 255 the clock frequency of SCK_S is at minimum.

Which level of variations of step frequencies is acceptable depends on the application. At high microstep resolutions the step rate can be a multiple of the SPI rate without impact on the motor smoothness.

CLOCK FREQUENCY f_{SCK_S} [Hz]

The frequency f_{SCK_S} [Hz] of the stepper motor driver chain clock signal SCK_S is given by

$$f_{SCK_S} = \frac{f_{CLK}}{2 * (CLK2_DIV + 1)}$$

- For smooth motion even at high step frequencies the clock frequency f_{SCK_S} [Hz] should be set as high as possible by choosing the parameter $CLK2_DIV$ in consideration of the data clock frequency limit defined by the slowest stepper motor driver chip of the daisy chain.
- If step frequencies reach the order of magnitude of the maximum datagram frequency (determined by the clock frequency of SCK_S and by the datagram length) the step frequencies may jitter, which is an inherent property of SPI communication. Up to which level variations of step frequencies are acceptable depends on the application.

For most applications, a setting of $CLK2_DIV = 7$ is recommended.

DATAGRAM FREQUENCY $f_{DATAGRAM}$ [Hz]

The datagram frequency $f_{DATAGRAM}$ [Hz] is given by

$$f_{DATAGRAM} = \frac{f_{SCK_S}[Hz]}{1 + DATAGRAM_LENGTH[bit] + 1}$$

This formula is an approximation for the upper limit.

- For $CLK2_DIV = 7$ the processing of the NxM bit (*next motor bit*) requires 1 SPI clock cycle.
- The processing of the NxM bit requires 1.5 SPI clock cycles for $CLK2_DIV > 7$.

As result for a chain of three drivers with 12 bit datagram length each, the upper limit of the datagram frequency is

$$f_{DATAGRAM}[Hz] = \frac{f_{SCK_S}[Hz]}{1 + 3 * (12 + 1) + 1} = \frac{f_{SCK_S}[Hz]}{41}$$

8.2.5.4 LSMD - Last Stepper Motor Driver

For the datagram configuration in SPI mode the number of stepper motor drivers is important. It is represented by the parameter *LSMD* (*last stepper motor driver*).

| SETTING THE NUMBER OF STEPPER MOTOR DRIVERS | |
|---|----------------------|
| <i>LSMD</i> | Number motor drivers |
| %00 (=0) | 1 motor driver |
| %01 (=1) | 2 motor drivers |
| %10 (=2) | 3 motors drivers |
| %11 (=3) | <i>not allowed!</i> |

8.2.5.5 *continuous_update*

The TMC429 in SPI mode sends datagrams to the stepper motor driver chain only on demand. The *continuous_update* bit offers two possibilities.

| CONTINUOUS_UPDATE SETTINGS | |
|-----------------------------------|--|
| <i>continuous_update</i> | Description |
| 0 | <p>No datagrams are sent during rest periods if <i>continuous_update</i> is set to 0. This reduces communication traffic. The multiplexed reference switch inputs are only processed while datagrams are sent to the stepper motor driver chain.</p> <p>A stepper motor (stopped at reference switch / switch became inactive) stays at rest until a new datagram is sent from the TMC429 to the stepper motor driver chain. Afterwards, the stepper motor can be either moved into the direction opposite to the reference switch or it can be moved in both directions by disabling the automatic stop function.</p> <p><i>There is no automatic coil current scaling if the motors are at rest!</i></p> <p><i>This setting is recommended for low power applications, e.g. if the stepper motor drivers shall be put into standby mode.</i></p> |
| 1 | <p>When using a reference switch multiplexer, with the reference switches configured to stop associated stepper motors automatically, the configuration bit <i>continuous_update</i> must be set to 1. This forces the periodic sending of datagrams to the stepper motor driver chain and samples the reference switches periodically, if all stepper motors are at rest. With this, a stepper motor restarts if the associated reference switch becomes inactive.</p> <p>For automatic coil current scaling this bit must be set to 1. The coil current is scaled even though all motors are at rest (<i>velocity=0</i>). Refer to chapter 8.1.9.</p> <p><i>This is the normal setting enabling all features.</i></p> |

The continuous update datagram frequency is given by

$$f_{cupd_s}[\text{Hz}] = \frac{f_{CLK}[\text{Hz}] * \left(\frac{1}{2^{RAMP_DIV_0}} + \frac{1}{2^{RAMP_DIV_1}} + \frac{1}{2^{RAMP_DIV_2}} \right)}{32768}$$

where

RAMP_DIV_0, *RAMP_DIV_1*, and *RAMP_DIV_2* are the *RAMP_DIV* settings of the three stepper motors.

9 Reference Switch Inputs

9.1 Reference Switch Configuration, *mot1r*, and *refmux*

mot1r is useful for single or dual motor applications with the TMC429-I. It can be used in SPI mode and in Step/Dir mode. In a configuration with SPI drivers and external reference multiplexer (*refmux* =1) all reference switches are available even with TMC429-I. This configuration may also be useful with the TMC429-PI24. Without multiplexing the TMC429-PI24 offers three left switches but only two right switches.

| ASSOCIATION OF REFERENCE INPUTS DEPENDING ON CONFIGURATION BITS | | | | | | | |
|---|--------------------------|-------------|--------------|-------------|--------------|-------------|--------------|
| <i>refmux</i> TMC429-I and TMC429-PI24 SPI only | <i>mot1r</i> SPI only | Motor 1 | | Motor 2 | | Motor 3 | |
| | | left switch | right switch | left switch | right switch | left switch | right switch |
| 0 | 0 | REF1 | % | REF2 | % | REF3 | % |
| 0 | 1 | REF1 | REF3 | REF2 | % | % | % |
| 1 | 0 | REF1_LEFT | REF1_RIGHT | REF2_LEFT | REF2_RIGHT | REF3_LEFT | REF3_RIGHT |
| 1 | 1 | REF1_LEFT | REF1_RIGHT | REF2_LEFT | REF2_RIGHT | REF3_LEFT | REF3_RIGHT |

NOTES

- With *refmux* set to 0, the association of the reference switch inputs REF1, REF2, and REF3 depend on the setting of *mot1r*.
- If reference switch multiplexing is enabled, *mot1r* is ignored.
- Power-on default values are *refmux*=0 and *mot1r*=0.
- After power-on-reset, the default setting (*refmux*=0 and *mot1r*=0) selects the basic single reference switch configuration as outlined in Figure 9.2.

TMC429-LI AND TMC429-PI24

The TMC429-LI offers two reference switches (right and left) for each stepper motor. Therefore the TMC429-LI does not need to be configured with *refmux* and *mot1r*.

The TMC429-PI24 offers one left reference switch for each motor and a right reference switch for motor 1 and motor 2. *refmux* may be used with the TMC429-PI24 in SPI mode if a right reference switch for motor 3 is needed. *mot1r* has no relevance for the TMC429-PI24.

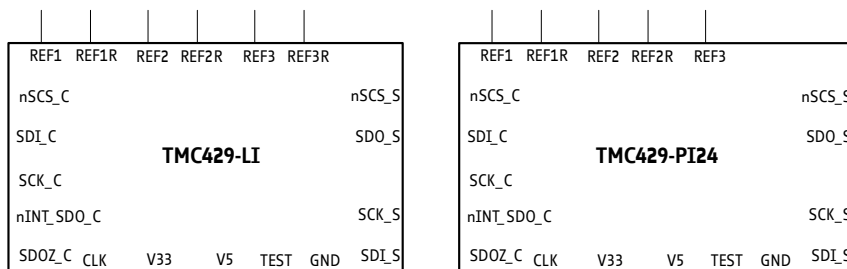

Figure 9.1 TMC429-LI has three right reference inputs. TMC429-PI24 has two right reference inputs.

TMC429-I

The TMC429-I offers three reference switch inputs, which can be used *left-side-only* or *two-one-zero* as shown in Figure 9.2 and in Figure 9.3.

mot1r is used to set the reference switch configuration (*left-side-only* resp. *two-one-zero*).

refmux is used for the configuration of multiplexing the three reference switches (e.g. with 74HC157 multiplexer).

LEFT-SIDE-ONLY

The power-on default value of *mot1r* is 0. With this default value, REF1 is associated to the left reference switch of stepper motor #1, REF2 is associated to the left reference switch of stepper motor #2, and REF3 is associated to the left reference switch of stepper motor #3.

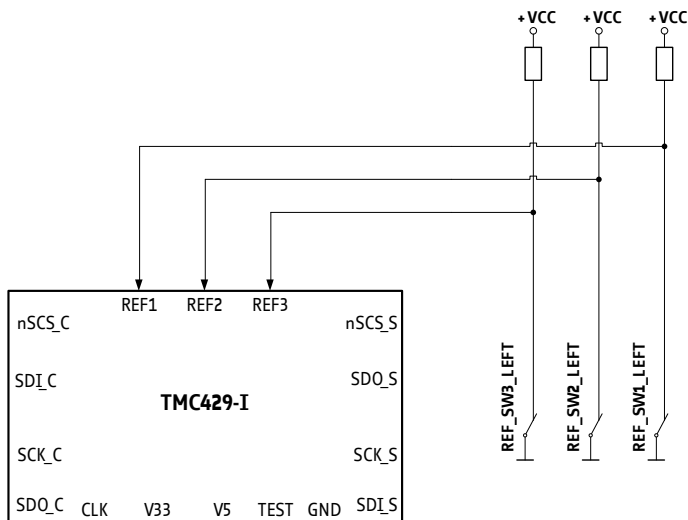

Figure 9.2 Reference switch configuration *left-side-only* for *mot1r*=0 (and *refmux*=0)

TWO-ONE-ZERO

If *mot1r* is set to 1 the input REF1 is also associated with the left reference switch of stepper motor #1. REF2 is also associated to the left reference switch of stepper motor #2. But, the input REF3 is associated to the *right reference switch* of stepper motor #1 and no reference switch input is associated to stepper motor number#3 (see Figure 9.3)

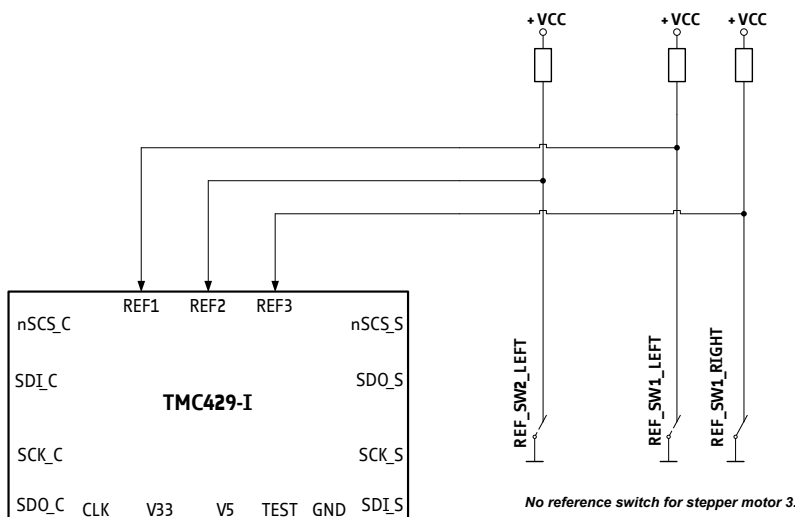

Figure 9.3 Reference switch configuration *two-one-zero* for *mot1r*=1 (and *refmux*=0)

MULTIPLEXING (SPI DRIVER MODE, ONLY)

The *refmux* bit must be set to 1 to enable reference switch multiplexing (see Figure 9.4). For the two variants TMC429-PI24 and TMC429-LI, the reference switch multiplexing also works for *csCommonIndividual=1* using three separate driver selection signals (*nSCS_S*, *nSCS2*, *nSCS3*) if the signal *nSCS_S* is connected to the multiplexer 74HC157 according to Figure 9.7.

If *continuous_update* is 1, internal reference switch bits are updated periodically, even if all stepper motors are at rest. Additionally, the chip select signal *nSCS_S* for the stepper motor driver chain is also the control signal for a multiplexer in case of using the reference switch multiplexing option (see Figure 9.4). So, the *continuous_update* must be set to 1 if automatic stop by reference switches is enabled, if six multiplexed reference switches are used, and to get the states of reference switches while all stepper motors are at rest.

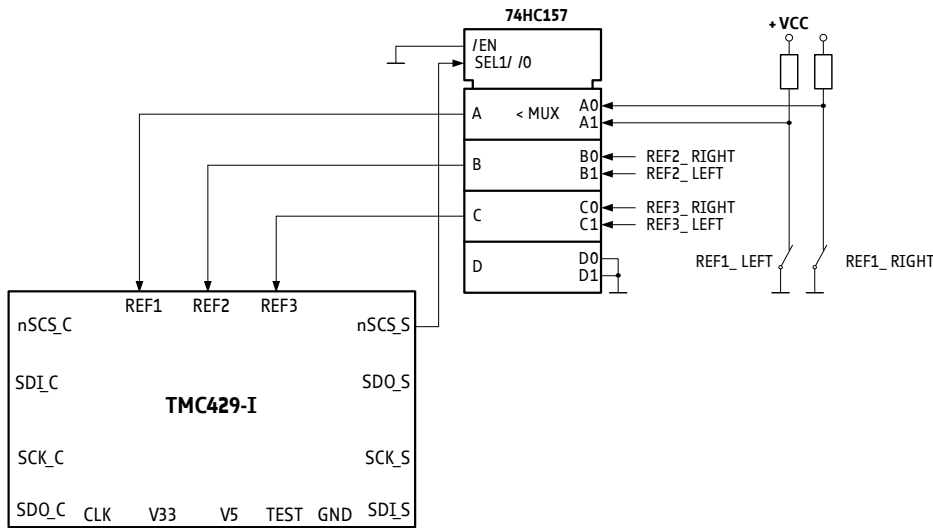

Figure 9.4 Reference switch multiplexing with 74HC157 (refmux=1)

9.2 Triple Switch Configuration

The programmable tolerance range around the reference switch position is useful for a triple switch configuration, as outlined in Figure 9.5. In this configuration two switches are used as automatic stop switches and one additional switch is used as the reference switch between the left stop switch and the right stop switch. The left stop switch and the reference switch are connected in series. In order to use the reference switch, program a tolerance range into the register *DX_REF_TOLERANCE*. This disables the automatic stop within the tolerance range of the reference switch. The homing procedure can use the right switch to make sure, that the reference switch is found properly. The TMC429 can automatically check the correct position of the driver whenever the reference switch is passed.

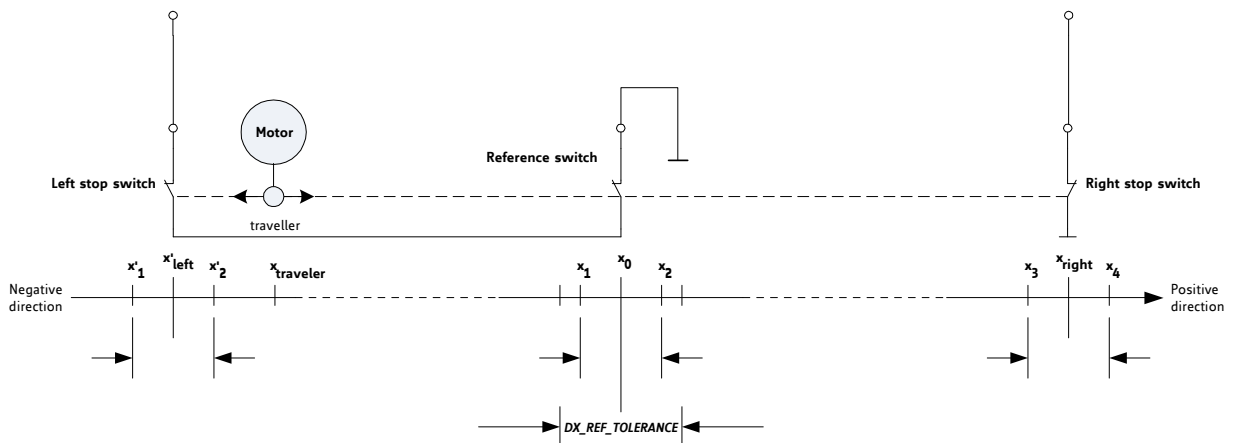

Figure 9.5 Triple switch configuration left stop switch – reference switch – right stop switch

9.3 Homing Procedure

In order to home the drive, the reference switch position x_{ref} must be determined after each power on (see Figure 9.6).

PROCEED AS FOLLOWS:

1. Due to mechanical inaccuracy of switches, the reference switch is active within the following range: $x_1 < x_{ref} < x_2$, where x_1 and x_2 may vary. If the traveler is within the range $x_1 < x_{traveler} < x_2$ at the start of the homing procedure, it is necessary to leave this range, because the associated reference switch is active. A dummy write access to $X_LATCHED$ initializes the position latch register.
2. With the traveler within the range $x_2 < x_{traveler} < x_{max}$ and the register $X_LATCHED$ initialized, the position x_2 can simply be determined by motion with a target position X_TARGET set to $-x_{max}$.
3. When reaching position x_2 the position is latched automatically.
4. With stop switch enabled, the stepper motor automatically stops if the position x_2 is reached.
5. Now, set the $DX_REF_TOLERANCE$ in order to allow motion within the active reference switch range $x_1 < x_{ref} < x_2$ and to move the traveler to a position $x_{traveler} < x_1$ if desired.
6. Afterwards initialize the register $X_LATCHED$ again to latch the position x_1 by a motion to a target position $x_{traveler} < x_1$.
7. When the positions x_1 and x_2 are determined the reference position $x_{ref} = (x_1 + x_2) / 2$ can be set. Finally, one should move to the target position $X_TARGET = x_{ref}$ and set $X_TARGET := 0$ and $X_ACTUAL := 0$ when reached.

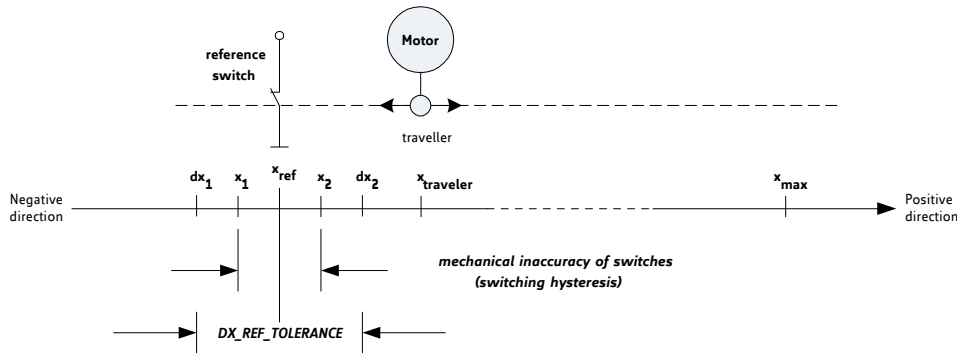

Figure 9.6 Reference search

9.4 Simultaneous Start of up to Three Stepper Motors

Starting stepper motors simultaneously can be achieved by sending successive datagrams starting the stepper motors. If the delay between those datagrams is of the magnitude of some microseconds, the stepper motors can be considered as started simultaneously. Feeding the reference switch signals through or gates (see Figure 9.7) allows exact simultaneous start of the stepper motors under software control.

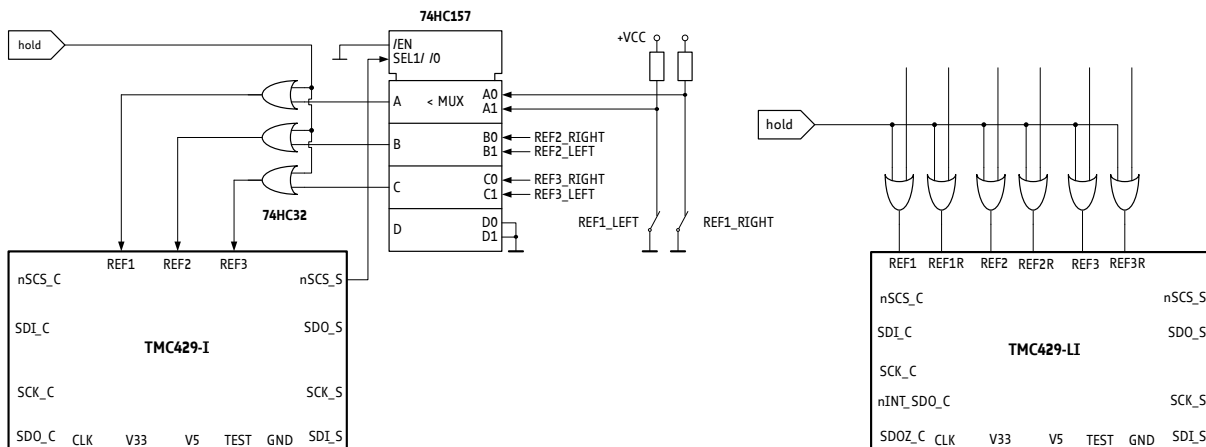

Figure 9.7 Reference switch gating for exact simultaneous stepper motor start

10 Step/Dir Drivers

Step/Dir drivers contain an internal sequencer. The Step/Dir interface is a simple and universal interface for real time motion control. The internal sequencer of the TMC429 and its associated RAM table is not used for Step/Dir drivers. All additional control functions like current control have to be provided by the microcontroller directly communicating to the driver.

The Step/Dir mode is enabled if the control bit *en_sd* (enable Step/Dir) of the *IF_CONFIGURATION_429* register is set to 1.

10.1 Timing

The timing of the Step/Dir interface should be adapted to the requirements of the driver and the transmission line. The minimum pulse width may be limited.

The timing of the Step/Dir interface is controlled by the four LSBs [3..0] of the *CLK2_DIV* of the global parameter register. Here, the *CLK2_DIV*[3..0] is named *STPDIV_429*.

For a given clock frequency f_{CLK} [MHz] of the TMC429, the length t_{STEP} [μs] of a step pulse is

$$t_{STEP[\mu s]} = 16 * \frac{1 + STPDIV_429}{f_{CLK[MHz]}}$$

- For a clock frequency f_{CLK} [MHz] of 16MHz the step pulse length can be programmed in integer multiple of 1μs by *STPDIV_429*.
- The *STPDIV_429* has to be set compatible to the upper step frequency $f_{STEP} = 1/t_{STEP}$ which is used.
- The first step pulse after a change of direction is delayed by $t_{DIR2STP}$ which is equal to t_{STEP} to avoid setup time violations of the Step/Dir power stage.

MAXIMUM STEP FREQUENCIES

Generally, the maximum step pulse frequency is f_{STEP_MAX} [MHz] = f_{CLK} [MHz] / 32.

For a clock frequency f_{CLK} [MHz] = 16 MHz the maximum step pulse frequency f_{STEP_MAX} is 500kHz.

For a clock frequency f_{CLK} [MHz] = 32 MHz the maximum step pulse frequency f_{STEP_MAX} is 1MHz.

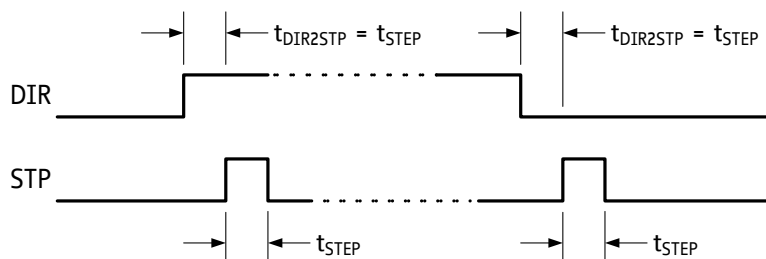

Figure 10.1 Step/Dir timing (*en_sd* = 1; *step_half* = 0)

11 SPI Mode Driver Interface

The TMC429 contains a microstep sequencer, which directly connects to SPI stepper motor drivers. The internal sequencer provides the full set of control signals for three stepper motor driver ICs. The SPI datagram is individually configurable for each stepper motor driver chip of the daisy chain. This is necessary, because there is no standard for the sequence, the meaning, and the number of the control bits for serial stepper motor drivers. The stepper motor driver datagram configuration adapts the specific sequence of control bits required by the driver IC. It is stored within the first 32 addresses representing 64 values of the on-chip RAM (see chapter 10).

The TMC429 is simply configurable by sending a fixed sequence of datagrams to initialize it after power-up. Once initialized, the TMC429 autonomously generates the datagrams for the stepper motor driver daisy chain without any additional interventions of the microcontroller. To operate the TMC429 in *SPI mode* set *en_sd* to 0 (see chapter 0). The addressing of the stepper motor drivers within a daisy chain is determined by their position in the SPI chain: the last IC in the chain is motor driver 0.

For TRINAMIC drivers, configuration data is provided.

11.1 Bus Signals

| Signal Description | TMC429 ↔ Stepper Driver |
|--------------------|-------------------------|
| Bus clock input | SCK_S |
| Serial data input | SDI_S |
| Serial data output | SDO_S |
| Chip select input | nSCS_S |

11.2 Timing

The timing of the serial stepper motor interface is similar to that of the microcontroller interface.

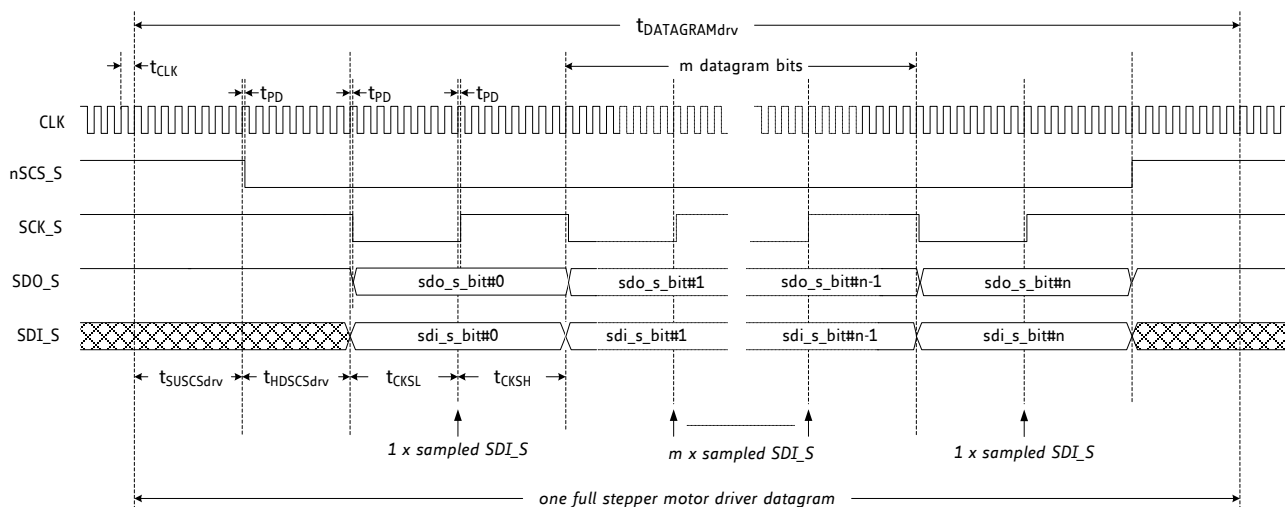

Figure 11.1 Timing diagram of the serial stepper motor driver interface

EXPLANATORY NOTES

- The clock divider provides 16 up to 512 clock cycles (t_{CLK}) for a serial driver interface data clock period.
- The default duration of a clock period ($t_{SCKCL} + t_{SCKCH}$) of the signal nSCS_S is 16+16=32 clock periods of the clock signal CLK.
- The minimal duration of a serial interface clock period ($t_{SCKCL} + t_{SCKCH}$) is 8+8=16 clock cycles of signal CLK. Set $CLK_DIV=7$. This setting provides best performance in most cases.
- The polarities of the signals nSCS_S and SCK_S are programmable to use driver chips with inverted polarities without additional glue logic.
- The input SDI_S of the serial driver interface must always be driven to a defined level. To avoid high impedance (Z) at this input pin while the stepper motor driver chain is idle, a pull-up resistor or a pull-down resistor of 10 k Ω is required at the input.

| TIMING CHARACTERISTICS OF SERIAL STEPPER MOTOR DRIVER INTERFACE | | | | | |
|---|---|-----------------|-----|----------------------|-------------|
| Symbol | Parameter | Min | Typ | Max | Unit |
| t _{SUSCSdrv} | | 8 | 16 | 256 | CLK periods |
| t _{HDSCSdrv} | | 8 | 16 | 256 | CLK periods |
| t _{CKSL} | | 8 | 16 | 256 | CLK periods |
| t _{CKSH} | | 8 | 16 | 256 | CLK periods |
| t _{DAMAGRAMdrv} | Datagram Length | 8+8+1*16+8+8=48 | | 512+64*512+512=33792 | CLK periods |
| t _{DAMAGRAMdrv} | Datagram Duration for 1 - 64 bits @ fCLK = 16 MHz | 3 | | 2112 | µs |
| t _{DAMAGRAMdrv} | Datagram Duration for 1 - 64 bits @ fCLK = 32 MHz | 3 | | 1056 | µs |
| t _{PD} | CLK-rising-edge to Outputs Delay | | 5 | | ns |

11.3 RAM Address Partitioning and Data Organization

The SPI datagram for each stepper motor driver is composed of *internal sequencer output signals* provided by the microstep unit of the TMC429 individually for each stepper motor. Each internal sequencer output signal is represented by a five bit code word called *driver configuration code*. The order of internal sequencer output signals forming the SPI datagrams for the stepper motor driver daisy chain is defined by the order of driver configuration code words in the configuration RAM area.

The on-chip RAM capacity is 128 x 6 bit. The 128 on-chip RAM cells of 6 bit width are addressed via 64 addresses with 2 x 6 data words. From the addressing point of view, the address space enfolds 64 addresses of 12 bit wide data. The 64 addresses are partitioned into two ranges of 32 addresses – selected by the register RAM select *RRS* bit.

The registers of the TMC429 are addressed with *RRS*=0.
The on-chip RAM is addressed with *RRS*=1.

| PARTITIONING OF THE ON-CHIP RAM ADDRESS SPACE | | | | | | | | | | | | | | | | | | | | | | | | | | | | | | | |
|--|---------|--|----|--------------------------|---|---|---|---|---|---|---|---|---|---|---|---------------------------|---|---|---|---|---|---|---|---|---|---|---|---|---|---|---|
| 32 BIT DATAGRAM SENT FROM A µC TO THE TMC429 VIA PIN SDI_C | | | | | | | | | | | | | | | | | | | | | | | | | | | | | | | |
| 3 | 3 | 2 | 2 | 2 | 2 | 2 | 2 | 2 | 2 | 2 | 2 | 1 | 1 | 1 | 1 | 1 | 1 | 1 | 1 | 1 | 1 | 9 | 8 | 7 | 6 | 5 | 4 | 3 | 2 | 1 | 0 |
| 1 | 0 | 9 | 8 | 7 | 6 | 5 | 4 | 3 | 2 | 1 | 0 | 9 | 8 | 7 | 6 | 5 | 4 | 3 | 2 | 1 | 0 | | | | | | | | | | |
| RRS | ADDRESS | | RW | DATA | | | | | | | | | | | | | | | | | | | | | | | | | | | |
| | | | | data @ odd RAM addresses | | | | | | | | | | | | data @ even RAM addresses | | | | | | | | | | | | | | | |
| 1 | 0 | 32 x (2x6 bit) <i>driver chain datagram configuration range</i> | | | | | | | | | | | | | | | | | | | | | | | | | | | | | |
| | | | | | | | | | | | | | | | | | | | | | | | | | | | | | | | |
| 1 | 1 | 32 x (2x6 bit) <i>quarter period sine wave LUT range</i> | | | | | | | | | | | | | | | | | | | | | | | | | | | | | |
| | | | | | | | | | | | | | | | | | | | | | | | | | | | | | | | |

DRIVER CHAIN DATA CONFIGURATION

The sequencer internally generates a number of control signals available for transmission to SPI driver ICs. These sequencer output signals are selected as configured by the internal stepper motor driver datagram configuration table.

The first 32 addresses are provided for the configuration of the serial stepper motor driver chain. Each of these 32 addresses stores two configuration words, composed of the so called *NxM* (next motor) bit together with the 5 bit wide driver configuration code. While sending a datagram, the driver

configuration code words are read sequentially beginning with the first address of the driver chain datagram configuration memory range. Each driver configuration code word selects a signal provided by the microstep unit.

MICROSTEP TABLE

The second 32 addresses are provided to store the microstep table. This table usually is a quarter period of a sine wave or of a periodic function, which has been optimized for a given motor type. Different stepper motors may step with different microstep resolutions, but the microstep look up table (LUT) is the same for all stepper motors controlled by one TMC429. Any quarter wave period stored in the microstep table is expanded automatically to a full period wave together with its 90° phase shifted wave.

NxM

The *NxM* bit tells the TMC429 that the last bit of a motor driver SPI register is reached. The TMC429 increments the internal stepper motor addressing counter and switches to the next driver in the chain after reading an SPI configuration word with *NxM*=1. If the internal stepper motor addressing counter is equivalent to the last stepper motor driver *LSMD* parameter, the datagram transmission is finished and the counter is preset to %00 for the next datagram transmission to the stepper motor driver chain.

The total data word width is six bit: five for an *internal sequencer output signals* and one *NxM* bit.

11.4 Stepper Driver SPI Datagram Configuration

A number of control signals are required to drive 2-phase stepper motors. The serial driver interface forms the link between the TMC429 and the stepper motor driver chain. The motor driver datagram configuration defines the order of the control signals serially sent from TMC429 to the stepper motor driver chain. To define the serial order of the control signals, *driver configuration codes* have to be written into the stepper motor driver datagram configuration area of the on-chip configuration RAM of the TMC429. The control signals required in a given application depend on the stepping mode (full step, half step, or microstep) and on additional options related to the stepper motor driver chips used. The TMC429 primarily provides a full set of control signals individually for each of the up to three stepper motors respectively stepper motor driver chips of the daisy chain. Mnemonics for *driver configuration codes* are given in the table below. The names of these signals may differ to the signal names of the used stepper motor drivers.

| STEPPER MOTOR DRIVER DATAGRAM CONFIGURATION | | | |
|---|---------------------------|--------|---|
| MNEMONIC | DRIVER CONFIGURATION CODE | | Function |
| | hex | bin | |
| DAC_A_0 | \$00 | %00000 | DAC A, bit 0 (LSB) |
| DAC_A_1 | \$01 | %00001 | DAC A, bit 1 |
| DAC_A_2 | \$02 | %00010 | DAC A, bit 2 |
| DAC_A_3 | \$03 | %00011 | DAC A, bit 3 |
| DAC_A_4 | \$04 | %00100 | DAC A, bit 4 |
| DAC_A_5 | \$05 | %00101 | DAC A, bit 5 (MSB) |
| PH_A | \$06 | %00110 | phase polarity bit A |
| FD_A | \$07 | %00111 | fast decay bit A |
| DAC_B_0 | \$08 | %01000 | DAC B, bit 0 (LSB) |
| DAC_B_1 | \$09 | %01001 | DAC B, bit 1 |
| DAC_B_2 | \$0A | %01010 | DAC B, bit 2 |
| DAC_B_3 | \$0B | %01011 | DAC B, bit 3 |
| DAC_B_4 | \$0C | %01100 | DAC B, bit 4 |
| DAC_B_5 | \$0D | %01101 | DAC B, bit 5 (MSB) |
| PH_B | \$0E | %01110 | phase polarity bit B |
| FD_B | \$0F | %01111 | fast decay bit B |
| zero | \$10 | %10000 | constant 0 |
| one | \$11 | %10001 | constant 1 |
| direction | \$12 | %10010 | 0 : up / 1 : down resp. counter clockwise / clockwise |
| step | \$13 | %10011 | step bit for Step/Dir control of drivers |
| UNUSED (these codes might be used for future devices) | \$14 | %10100 | |
| | \$15 | %10101 | |
| | \$16 | %10110 | |
| | \$17 | %10111 | |
| | \$18 | %11000 | |
| | \$19 | %11001 | |
| | \$1A | %11010 | |
| | \$1B | %11011 | |
| | \$1C | %11100 | |
| | \$1D | %11101 | |
| \$1E | %11110 | | |
| \$1F | %11111 | | |

FOR EACH COIL OF EACH MOTOR THE FOLLOWING FUNCTION BITS ARE PROVIDED:

- 6 bit control signals for the DAC (current control),
- 1 bit for the phase polarity, and
- 1 bit for fast decay (only for stepper motor driver chips which offer fast decay).

FOR BOTH COILS OF EACH MOTOR FURTHER FUNCTION BITS ARE PROVIDED:

- 1 constant configuration bit named *zero*,
- 1 constant configuration bit named *one*,
- 1 *direction* bit for Step/dir control of drivers, and
- 1 *step* bit for Step/Dir control of drivers.

Figure 11.2 outlines how to connect the control signals of the TMC429 with the signals used to control the digital part of a stepper motor driver.

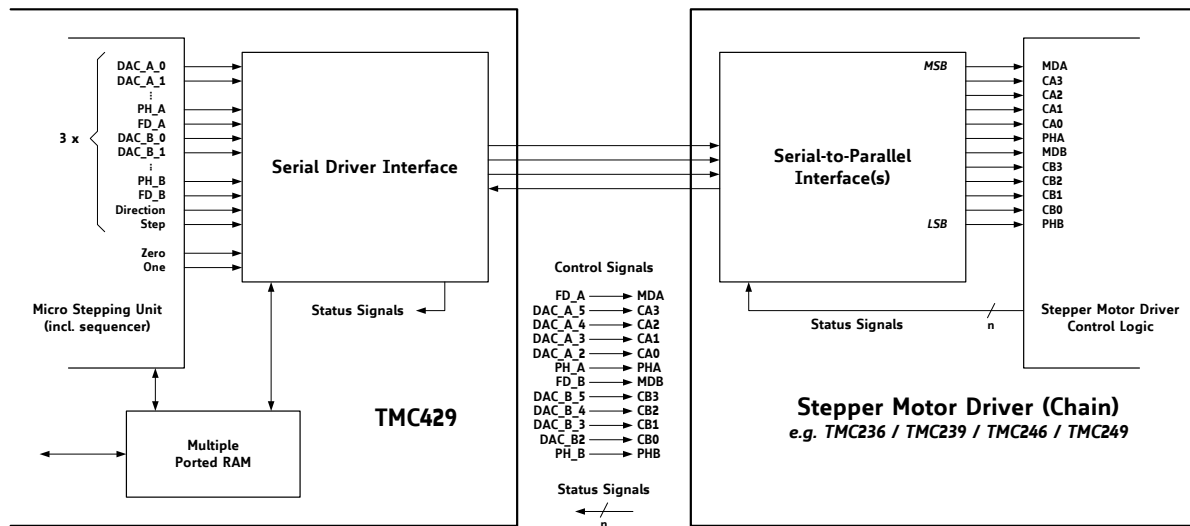

Figure 11.2 Serially transmitted control and status signals between TMC429 and driver chain

If fullstep operation of an SPI stepper motor is desired, e.g. at higher velocities, the driver configuration codes for the DAC bits can be replaced by constant '1' bits (signal code %11) on the fly during high velocity motion. This way, the microstep resolution does not need to be changed.

UNDERSTANDING THE CONFIGURABLE SPI DATAGRAM SEQUENCER

1. The TMC429 sends datagrams to the stepper motor driver chain only on demand. To guarantee the integrity of each datagram, the status of all *internal sequencer output signals* is buffered internally before sending.
2. Afterwards, the transmission starts with selection of the buffered *internal sequencer output signals* of the first motor (*SMDA=%00*) by reading the first *driver configuration code word* (even data word at on-chip RAM address %00000) from on-chip configuration RAM area.
3. The *driver configuration codes* select the *sequencer output signals* provided for the first stepper motor.
The first stepper motor is addressed until the *NxM* (next motor) bit is read from on-chip configuration RAM. The stepper motor driver address is incremented with each *NxM=1* as long as the current stepper motor driver address is below the value set by the parameter *LSMD* (last stepper motor driver). If the stepper motor driver address is equivalent to the *LSMD* parameter, *NxM=1* indicates the completion of the transmission.
4. Now, the stepper motor driver address counter of the serial interface is reinitialized to %00 and the unit waits for the next transmission request.

Note

- The order of *driver configuration codes* in the on-chip RAM configuration area determines the order of datagram bits for the stepper motor driver chain, whereas the prefixed *NxM* bit determines the stepper motor driver positions. If no *NxM* bit with a value of 1 is stored within the on-chip RAM, the TMC429 will send endlessly.
- The on-chip RAM has to be configured first!
- After power-on reset, the registers of the TMC429 are initialized in a way that no transmission of datagrams to the motor driver chain is required.
- Access to on-chip RAM is always possible, also during transmission of datagrams to the driver chain.

11.4.1 Initialization of On-Chip RAM by μ C after Power-On

After the automatic power-on reset all registers are initialized and all stepper motors are at rest. The on-chip RAM of the TMC429 is initialized with a default configuration for a TMC23x or TM24x stepper motor driver chain. Writing to TMC429 registers may cause action of the stepper motor units (initiated by the TMC429) which results in sending datagrams to the stepper motor driver chain!

Before moving a motor using other stepper motor drivers than TMC236/TMC239/TMC246/TMC249 in an SPI chain the on-chip RAM must be initialized.

11.4.2 Example for SPI Motor Driver Datagram Configuration

The following example demonstrates how to configure the datagram and shows what has to be stored within the on-chip RAM to represent the desired configuration. The given example refers to a driver chain of three TRINAMIC stepper motor drivers of type TMC236, TMC239, TMC246, or TMC249. From the TMC429 datagram configuration point of view, there is no difference between these drivers. All drivers have a serial interface of 12 bits length.

EXAMPLE CONFIGURATION:

- For the first and the second stepper motor driver of the chain the fast decay control bit (FD_A, FD_B) is fixed to 0. This setting can be beneficial in stand still.
- For the third driver the fast decay control bit is used. This sample gives smoothest microstepping.
- The sequence to be sent to the TMC429 for this configuration is outlined in the table below. In power-on default, fast decay fixed on is shown. This will result in best microstep precision and smoothest operation.

| DATAGRAM EXAMPLE AND RAM CONTENTS FOR THREE STEPPER MOTOR DRIVER CHAIN | | | | | | | | |
|--|---------------------|-----|--------------------|-------------|----------------|-------------------------------|---|------------------------|
| <i>Power-On default initialization values of the TMC429 are marked as {One}.</i> | | | | | | | | |
| Position within datagram | Driver | NxM | TMC429 signal code | RAM address | RAM data {POR} | TMC429 MNEMONIC {POR default} | | TMC23x TMC24x bit name |
| 0 | driver#1 (SMDA=%00) | 0 | \$10 | \$00 | \$10 {\$11} | Zero {One} | → | MDA |
| 1 | | 0 | \$05 | \$01 | \$05 | DAC_A_5 | → | CA3 |
| 2 | | 0 | \$04 | \$02 | \$04 | DAC_A_4 | → | CA2 |
| 3 | | 0 | \$03 | \$03 | \$03 | DAC_A_3 | → | CA1 |
| 4 | | 0 | \$02 | \$04 | \$02 | DAC_A_2 | → | CA0 |
| 5 | | 0 | \$06 | \$05 | \$06 | PH_A | → | PHA |
| 6 | | 0 | \$10 | \$06 | \$10 {\$11} | Zero {One} | → | MDB |
| 7 | | 0 | \$0D | \$07 | \$0D | DAC_B_5 | → | CB3 |
| 8 | | 0 | \$0C | \$08 | \$0C | DAC_B_4 | → | CB2 |
| 9 | | 0 | \$0B | \$09 | \$0B | DAC_B_3 | → | CB1 |
| 10 | | 0 | \$0A | \$0A | \$0A | DAC_B_2 | → | CB0 |
| 11 | | 1 | \$0E | \$0B | \$2E | PH_B | → | PHB |
| 12 | driver#2 (SMDA=%01) | 0 | \$10 | \$0C | \$10 {\$11} | Zero {One} | → | MDA |
| 13 | | 0 | \$05 | \$0D | \$05 | DAC_A_5 | → | CA3 |
| 14 | | 0 | \$04 | \$0E | \$04 | DAC_A_4 | → | CA2 |
| 15 | | 0 | \$03 | \$0F | \$03 | DAC_A_3 | → | CA1 |
| 16 | | 0 | \$02 | \$10 | \$02 | DAC_A_2 | → | CA0 |
| 17 | | 0 | \$06 | \$11 | \$06 | PH_A | → | PHA |
| 18 | | 0 | \$10 | \$12 | \$10 {\$11} | Zero {One} | → | MDB |
| 19 | | 0 | \$0D | \$13 | \$0D | DAC_B_5 | → | CB3 |
| 20 | | 0 | \$0C | \$14 | \$0C | DAC_B_4 | → | CB2 |
| 21 | | 0 | \$0B | \$15 | \$0B | DAC_B_3 | → | CB1 |
| 22 | | 0 | \$0A | \$16 | \$0A | DAC_B_2 | → | CB0 |
| 23 | | 1 | \$0E | \$17 | \$2E | PH_B | → | PHB |
| 24 | driver#3 (SMDA=%10) | 0 | \$07 | \$18 | \$07 {\$11} | FD_A {One} | → | MDA |
| 25 | | 0 | \$05 | \$19 | \$05 | DAC_A_5 | → | CA3 |
| 26 | | 0 | \$04 | \$1A | \$04 | DAC_A_4 | → | CA2 |
| 27 | | 0 | \$03 | \$1B | \$03 | DAC_A_3 | → | CA1 |
| 28 | | 0 | \$02 | \$1C | \$02 | DAC_A_2 | → | CA0 |
| 29 | | 0 | \$06 | \$1D | \$06 | PH_A | → | PHA |
| 30 | | 0 | \$0F | \$1E | \$0F {\$11} | FD_B {One} | → | MDB |
| 31 | | 0 | \$0D | \$1F | \$0D | DAC_B_5 | → | CB3 |
| 32 | | 0 | \$0C | \$20 | \$0C | DAC_B_4 | → | CB2 |
| 33 | | 0 | \$0B | \$21 | \$0B | DAC_B_3 | → | CB1 |
| 34 | | 0 | \$0A | \$22 | \$0A | DAC_B_2 | → | CB0 |
| 35 | | 1 | \$0E | \$23 | \$2E | PH_B | → | PHB |

With LSMD = %10 the (third) NxM bit at address \$23 (position 35) finishes the datagram transmission

The stepper motor driver datagram configuration can be accessed at any time without conflict, e.g. to change between a configuration using fast decay versus a configuration where fast decay is disabled.

CONFIGURATION DATAGRAM SEQUENCE FOR THE EXAMPLE

with – = don't cares

```

binary datagram specification      : hexadecimal datagram
%10000000-----000101-010000 : $80000510
%10000010-----000011-000100 : $82000304
%10000100-----000110-000010 : $84000602
%10000110-----001101-010000 : $86000D10
%10001000-----001011-001100 : $88000B0C
%10001010-----101110-001010 : $8a002E0A
%10001100-----000101-010000 : $8c000510
%10001110-----000011-000100 : $8e000304
%10010000-----000110-000010 : $90000602
%10010010-----001101-010000 : $92000D10
%10010100-----001011-001100 : $94000B0C
%10010110-----101110-001010 : $96002E0A
%10011000-----000101-000111 : $98000507
%10011010-----000011-000100 : $9a000304
%10011100-----000110-000010 : $9c000602
%10011110-----001101-001111 : $9e000D0F
%10100000-----001011-001100 : $a0000B0C
%10100010-----101110-001010 : $a2002E0A

```

11.4.3 Initialization of SPI Motor Drivers Using Cover Datagrams

Some stepper drivers require an initialization. When they are driven in SPI-Mode by a TMC429 there is no direct access from the μC to stepper motor drivers. The TMC429 supports tunneling of data from the μC to each stepper motor driver in the chain. This mechanism is called *cover datagram*. Also, status information from the drivers may need to be fed back to the μC for special functions. This is enabled by a set of two registers: *datagram-low-word* and *datagram-high-word* buffer data sent back from the drivers.

PROCEDURE:

- The TMC429 enables direct communication between the microcontroller and the stepper motor driver chain by sending a *cover datagram*.
- The position *cover_position* and actual length *cover_len* of a cover datagram is specified by writing them into a common register.
- Writing an up to 24 bit wide cover datagram to the register *cover_datagram* will fade in that cover datagram into the next datagram sent to the stepper motor driver chain.

11.5 Initialization of Microstep Look-Up Table

For an SPI driver chain the TMC429 provides a look-up table (LUT) of 64 values of 6 bit for microstepping. The microstep LUT can be adapted by storing an arbitrary quarter period of a periodic function to match individual stepper motor characteristics. It is common to use a sine wave function for microstepping. With that, the current of one phase is driven with the sine function whereas the other phase is driven with the cosine function.

To initialize the LUT for microstepping, load a quarter sine wave period into the microstep LUT. Each two successive values of the sine wave function are combined in one datagram similar to the driver configuration code words for the stepper motor driver chain configuration. The TMC429 automatically expands the quarter sine wave period to a full sine and cosine function. The necessary data values $y(i)$ to represent a quarter sine wave period for the microstep LUT are defined by

$$y(i) = \text{int} \left[\frac{1}{2} + 64 * \sin \left(\frac{1}{4} * 2 * \pi * \frac{i}{64} \right) \right]$$

with $i = \{ 0, 1, 2, 3, \dots, 60, 61, 62, 63 \}$

where the conditional replacement $y(i) := 63$ for $y(i) > 63$ has to be done. The last five values (which are calculated to be 64) have to be replaced by 63.

With this replacement one finally gets $y(i) = \{ 0, 2, 3, 5, 6, 8, 9, 11, 12, 14, 16, 17, 19, 20, 22, 23, 24, 26, 27, 29, 30, 32, 33, 34, 36, 37, 38, 39, 41, 42, 43, 44, 45, 46, 47, 48, 49, 50, 51, 52, 53, 54, 55, 56, 56, 57, 58, 59, 59, 60, 60, 61, 61, 62, 62, 62, 62, 63, 63, 63, 63, 63, 63, 63 \}$.

The power-on reset default initialization of the TMC429 sine wave LUT is with offset for TMC236/TMC239/TMC246/TMC249 with mixed decay control = One (ON).
Step/Dir control: TMC260/TMC261/TMC262 have their own optimized build-in sine wave look-up table.

| SCHEME OF 1/4 SINE WAVE PERIOD WITH 6 BIT RESOLUTION AND 64 (32 X 2) VALUES | | | | | | | | | | | | | | | | | | | | | | | | | | | | | | | | |
|---|---------|---|---|---|---|----|------------|--------------------------|---|---|---|---|------------|---------------------------|----|---|---|---|---|---|---|---|---|---|---|---|---|---|---|---|---|---|
| 32 BIT DATAGRAM SENT FROM A μ C TO THE TMC429 VIA PIN SDI_C | | | | | | | | | | | | | | | | | | | | | | | | | | | | | | | | |
| 3 3 2 2 2 2 2 2 2 2 2 2 1 1 1 1 1 1 1 1 1 1 9 8 7 6 5 4 3 2 1 0 | | | | | | | | | | | | | | | | | | | | | | | | | | | | | | | | |
| 1 0 9 8 7 6 5 4 3 2 1 0 9 8 7 6 5 4 3 2 1 0 | | | | | | | | | | | | | | | | | | | | | | | | | | | | | | | | |
| RRS | ADDRESS | | | | | RW | DATA | | | | | | | | | | | | | | | | | | | | | | | | | |
| | | | | | | | $(x)_{10}$ | data @ odd RAM addresses | | | | | $(x)_{10}$ | data @ even RAM addresses | | | | | | | | | | | | | | | | | | |
| 1 | 1 | 0 | 0 | 0 | 0 | 0 | 0 | 2 | 0 | 0 | 0 | 0 | 1 | 0 | 0 | 0 | 0 | 0 | 0 | 0 | 0 | 0 | 0 | 0 | 0 | 0 | 0 | 0 | 0 | 0 | 0 | |
| | | 0 | 0 | 0 | 0 | 1 | | 5 | 0 | 0 | 0 | 1 | 0 | 1 | 3 | 0 | 0 | 0 | 0 | 1 | 1 | 0 | 0 | 0 | 0 | 1 | 1 | 0 | 0 | 0 | 0 | |
| | | 0 | 0 | 0 | 1 | 0 | | 8 | 0 | 0 | 1 | 0 | 0 | 0 | 6 | 0 | 0 | 0 | 1 | 1 | 0 | 0 | 0 | 0 | 1 | 1 | 0 | 0 | 0 | 0 | 0 | 0 |
| | | 0 | 0 | 0 | 1 | 1 | | 11 | 0 | 0 | 1 | 0 | 1 | 1 | 9 | 0 | 0 | 1 | 0 | 0 | 1 | 1 | 0 | 0 | 1 | 0 | 0 | 1 | 0 | 0 | 0 | 0 |
| | | 0 | 0 | 1 | 0 | 0 | | 14 | 0 | 0 | 1 | 1 | 1 | 0 | 12 | 0 | 0 | 1 | 1 | 0 | 0 | 0 | 0 | 0 | 1 | 1 | 0 | 0 | 0 | 0 | 0 | 0 |
| | | : | : | : | : | : | | : | : | : | : | : | : | : | : | : | : | : | : | : | : | : | : | : | : | : | : | : | : | : | : | |
| | | 1 | 1 | 0 | 1 | 1 | | 62 | 1 | 1 | 1 | 1 | 1 | 0 | 62 | 1 | 1 | 1 | 1 | 1 | 1 | 0 | 0 | 0 | 0 | 1 | 1 | 1 | 1 | 1 | 0 | 0 |
| | | 1 | 1 | 1 | 0 | 0 | | 63 | 1 | 1 | 1 | 1 | 1 | 1 | 63 | 1 | 1 | 1 | 1 | 1 | 1 | 1 | 1 | 1 | 1 | 1 | 1 | 1 | 1 | 1 | 1 | 1 |
| | | 1 | 1 | 1 | 0 | 1 | | 63 | 1 | 1 | 1 | 1 | 1 | 1 | 63 | 1 | 1 | 1 | 1 | 1 | 1 | 1 | 1 | 1 | 1 | 1 | 1 | 1 | 1 | 1 | 1 | 1 |
| | | 1 | 1 | 1 | 1 | 0 | | 63 | 1 | 1 | 1 | 1 | 1 | 1 | 63 | 1 | 1 | 1 | 1 | 1 | 1 | 1 | 1 | 1 | 1 | 1 | 1 | 1 | 1 | 1 | 1 | 1 |
| | | 1 | 1 | 1 | 1 | 1 | | 63 | 1 | 1 | 1 | 1 | 1 | 1 | 63 | 1 | 1 | 1 | 1 | 1 | 1 | 1 | 1 | 1 | 1 | 1 | 1 | 1 | 1 | 1 | 1 | 1 |

These 64 values represent a quarter sine period in the interval $[0 \dots \pi/4]$ which is expanded automatically by the TMC429 to a full sine cosine period (see section 11.5.1).

The table is sent to the on-chip RAM of the TMC429 by 32 datagrams:

| % binary representation of the datagram | : decimal represented pair of values (separated by & character) | : \$ hexadecimal representation |
|--|--|---------------------------------|
| % 11 0000 0 00000000 00 000010 00 000000 | : 2 & 0 | : \$C0000200 |
| % 11 0001 0 00000000 00 000101 00 000011 | : 5 & 3 | : \$C2000503 |
| % 11 0010 0 00000000 00 001000 00 000110 | : 8 & 6 | : \$C4000806 |
| % 11 0011 0 00000000 00 001011 00 001001 | : 11 & 9 | : \$C6000B09 |
| % 11 0100 0 00000000 00 001110 00 001100 | : 14 & 12 | : \$C8000E0C |
| % 11 0101 0 00000000 00 010001 00 010000 | : 17 & 16 | : \$CA001110 |
| % 11 0110 0 00000000 00 010100 00 010011 | : 20 & 19 | : \$CC001413 |
| % 11 0111 0 00000000 00 010111 00 010110 | : 23 & 22 | : \$CE001716 |
| | | |
| % 11 0100 0 00000000 00 011010 00 011000 | : 26 & 24 | : \$D0001A18 |
| % 11 0101 0 00000000 00 011101 00 011011 | : 29 & 27 | : \$D2001D1B |
| % 11 0101 0 00000000 00 100000 00 011110 | : 32 & 30 | : \$D400201E |
| % 11 0101 0 00000000 00 100010 00 100001 | : 34 & 33 | : \$D6002221 |
| % 11 0110 0 00000000 00 100101 00 100100 | : 37 & 36 | : \$D8002524 |
| % 11 0110 0 00000000 00 100111 00 100110 | : 39 & 38 | : \$DA002726 |
| % 11 0111 0 00000000 00 101010 00 101001 | : 42 & 41 | : \$DC002A29 |
| % 11 0111 0 00000000 00 101100 00 101011 | : 44 & 43 | : \$DE002C2B |
| | | |
| % 11 1000 0 00000000 00 101110 00 101101 | : 46 & 45 | : \$E0002E2D |
| % 11 1001 0 00000000 00 110000 00 101111 | : 48 & 47 | : \$E200302F |
| % 11 1001 0 00000000 00 110010 00 110001 | : 50 & 49 | : \$E4003231 |
| % 11 1001 0 00000000 00 110100 00 110011 | : 52 & 51 | : \$E6003433 |
| % 11 1010 0 00000000 00 110110 00 110101 | : 54 & 53 | : \$E8003635 |
| % 11 1010 0 00000000 00 111000 00 110111 | : 56 & 55 | : \$EA003837 |
| % 11 1011 0 00000000 00 111001 00 111000 | : 57 & 56 | : \$EC003938 |
| % 11 1011 0 00000000 00 111011 00 111010 | : 59 & 58 | : \$EE003B3A |
| | | |
| % 11 1100 0 00000000 00 111100 00 111011 | : 60 & 59 | : \$F0003C3B |
| % 11 1101 0 00000000 00 111101 00 111100 | : 61 & 60 | : \$F2003D3C |
| % 11 1101 0 00000000 00 111110 00 111101 | : 62 & 61 | : \$F4003E3D |
| % 11 1101 0 00000000 00 111110 00 111110 | : 62 & 62 | : \$F6003E3E |
| % 11 1110 0 00000000 00 111111 00 111111 | : 63 & 63 | : \$F8003F3F |
| % 11 1110 0 00000000 00 111111 00 111111 | : 63 & 63 | : \$FA003F3F |
| % 11 1111 0 00000000 00 111111 00 111111 | : 63 & 63 | : \$FC003F3F |
| % 11 1111 0 00000000 00 111111 00 111111 | : 63 & 63 | : \$FE003F3F |

NOTE

- These 32 datagrams for initialization of a quarter sine wave period microstep look-up table are sufficient for all programmable microstep resolutions.
- If microstepping is used for at least one stepper motor, these 32 datagrams have to be sent once to the TMC429 for initialization of the microstep table after power-on reset.
- The initialization of the microstep look-up table is not necessary, if full stepping is used for all stepper motors.
- A complete initialization of the microstep look-up table is recommended to avoid trouble caused by missing look-up table entries.
- A fully initialized microstep look-up table allows the selection of individual microstep resolutions for different stepper motors.

FURTHER FORMULAS FOR SINE WAVE LOOK-UP TABLES

A sine wave table tailored to the motor gives the best fit with respect to equidistance of microsteps or concerning torque ripple. Alternatively, a sine wave look-up table based on the following formula can be used:

$$y(i) = \text{int} \left[63 * \sin \left(\frac{1}{4} * 2 * \pi * \frac{i}{64} \right) \right]$$

Even, adding some offset o within theoretical range from 0 to 63 might enhance the microstep behavior together with mixed decay:

$$y(i) = \text{int} \left[o + (63 - o) * \sin \left(\frac{1}{4} * 2 * \pi * \frac{i}{64} \right) \right]$$

Finally, a sine wave look-up table has to be tested within the application and might need some fine adjustments for optimization.

11.5.1 Stepping through the Wave Look-Up Table (LUT)

The 64 values of the wave look-up table (LUT) hold a quarter period of a sine wave, indexed from 0 to 63. This quarter sine wave is expanded to a full sine wave and full cosine wave by indexing the 64 values of the LUT. The LUT index is mapped from a wave index of a full period from 0 to 255. The stepping through the LUT is done with fixed increment width. The increment width is a power of two and it depends on the microstep resolution selection *USRS*. For motion in positive direction, the full period index is incremented from microstep to microstep. For motion in negative direction, the full period index is decremented from microstep to microstep. The sine is associated to phase A (*ph_a*) and the cosine is associated to phase B (*ph_b*). The phase bits represent the sign of the sine resp. cosine function. The polarity of the phase bit (*ph_a*, *ph_b*) and the polarity of the fast decay control bits (*fd_a*, *fd_b*) can be changed by the polarity bits within the global stepper motor parameter register (see section 0, page 45).

| PHASE BITS AND FAST DECAY CONTROL BITS | | | | | |
|--|-----------------|---------------------------|---------------------------|---------------------------|---------------------------|
| MSBs of full wave index (range) | Quadrant | <i>ph_a</i> <i>sin</i> | <i>ph_b</i> <i>cos</i> | <i>fd_a</i> <i>sin</i> | <i>fd_b</i> <i>cos</i> |
| %00 (0...63) | 1 st | 1 | 1 | 0 | 1 |
| %01 (64...127) | 2 nd | 1 | 0 | 1 | 0 |
| %10 (128...191) | 3 rd | 0 | 0 | 0 | 1 |
| %11 (192...255) | 4 th | 0 | 1 | 1 | 0 |

NOTE

- Always initialize the whole LUT to be sure to read valid wave values and use the MSB DAC bits (no matter what microstep resolution is set).
- The addressing starts with 0 after power-on reset.
- Changing the microstep resolution after some microsteps causes an offset for the addressing which has to be taken into account for positioning a stepper motor.
- With lower microstep resolutions, a slightly different motor behavior may be experienced for left and right rotation. This is, because the TMC236 drivers treat zero current differently depending on the polarity.

| WAVE LUT INDICES FOR DIFFERENT μ STEP RESOLUTIONS | | | | | | |
|---|-----------------|------------|------------------------------|-------------------------------|-------------------------------|------------------------------|
| <i>USRS</i> | increment width | | 1 st quadrant | 2 nd quadrant | 3 rd quadrant | 4 th quadrant |
| %110 | 1 | <i>sin</i> | 0, 1, 2, 3, ..., 61, 62, 63, | 63, 63, 62, 61, ..., 3, 2, 1, | 0, 1, 2, 3, ..., 61, 62, 63, | 63, 63, 62, 61, ..., 3, 2, 1 |
| | | <i>cos</i> | 63, 63, 62, 61, ..., 2, 1, | 0, 1, 2, 3, ..., 61, 62, 63, | 63, 63, 62, 61, ..., 3, 2, 1, | 0, 1, 2, 3, ..., 61, 62, 63 |
| %101 | 2 | <i>sin</i> | 0, 2, 4, 6, ..., 58, 60, 62, | 63, 60, 58, 56, ..., 4, 2, | 0, 2, 4, 6, ..., 58, 60, 62, | 63, 60, 58, 56, ..., 4, 2 |
| | | <i>cos</i> | 63, 60, 58, 56, ..., 4, 2, | 0, 2, 4, 6, ..., 58, 60, 62, | 63, 60, 58, 56, ..., 4, 2, | 0, 2, 4, 6, ..., 58, 60, 62 |
| %100 | 4 | <i>sin</i> | 0, 4, 8, 12, ..., 56, 60, | 63, 60, 56, ..., 12, 8, 4, | 0, 4, 8, 12, ..., 56, 60, | 63, 60, 56, ..., 12, 8, 4 |
| | | <i>cos</i> | 63, 60, 56, ..., 12, 8, 4, | 0, 4, 8, 12, ..., 56, 60, | 63, 60, 56, ..., 12, 8, 4, | 0, 4, 8, 12, ..., 56, 60 |
| %011 | 8 | <i>sin</i> | 0, 8, 16, 24, ..., 48, 56 | 63, 56, 48, 40, ..., 16, 8, | 0, 8, 16, 24, ..., 48, 56 | 63, 56, 48, 40, ..., 16, 8 |
| | | <i>cos</i> | 63, 56, 48, 40, ..., 16, 8, | 0, 8, 16, 24, ..., 48, 56 | 63, 56, 48, 40, ..., 16, 8, | 0, 8, 16, 24, ..., 48, 56 |
| %010 | 16 | <i>sin</i> | 0, 16, 32, 48, | 63, 48, 32, 16, | 0, 16, 32, 48, | 63, 48, 32, 16 |
| | | <i>cos</i> | 63, 48, 32, 16, | 0, 16, 32, 48, | 63, 48, 32, 16, | 0, 16, 32, 48 |
| %001 (HS) | 32 | <i>sin</i> | 0, 32, | 63, 32, | 0, 32, | 63, 32 |
| | | <i>cos</i> | 63, 32, | 0, 32, | 63, 32, | 0, 32 |
| %000 (FS) | 64 | <i>sin</i> | 0, | 63, | 0, | 63 |
| | | <i>cos</i> | 63, | 0, | 63, | 0 |

11.5.2 Partial Look-Up Table Initialization

If all stepper motors (except those driven in full step mode) are programmed to use the same microstep resolution constantly before a single microstep is processed, a partially initialized microstep table can be sufficient. With a partially initialized LUT, the microstep resolution *must be chosen before* any step is made after power-on reset. A partially initialized LUT should only be taken into account, if the memory of the host microcontroller is not big enough to store a full table.

Instead of a partial initialization of the TMC429 look-up table an initialization with a triangular function $f_{rhomb}(\varphi)$ is recommended.

11.5.3 Microstep Enhancement

Even for stepper motors optimized for sine-cosine control, it is possible to improve the microstep behavior by adapting the microstep look-up table. For different types of stepper motors a periodic trapezoidal or triangular function (similar to a sine function) as superposition or replacement might be a good choice. Taking the physics of stepper motors into account, the choice of the function can be determined by a single shape parameter σ .

The programmability of the microstep look-up table provides a simple and effective facility to enhance microstepping for a given type of two-phase stepper motor. Enhanced microstepping requires accurate current control. So, stepper motor driver chips with enabled and well tuned fast decay (resp. mixed decay) have to be used, e.g. TRINAMICs TMC236 / TMC239 / TMC246 / TMC249 driver chips.

Non-linearity (resulting from magnetic field configuration determined by shapes of pole shoes), ferromagnetic characteristics, and other stepper motor characteristics affect non-linearity in microstep behavior of stepper motors. The non-linearity of microstepping causes microstep positioning displacements, vibrations and noise, which can be reduced with an adapted microstep table. The best fitting microstep table can be determined by measuring the microstep motor behavior, e.g. using a laser pointer based on the sine-cosine microstepping table.

Nevertheless sine-cosine microstepping is a good first order approach for microstepping. The micro step enhancement possible with the TMC429 is based on a replacement of the look-up table initialization function $\sin(\varphi)$ used for sine-cosine microstepping by a function with the shape parameter σ . A quarter sine wave period is the basic approach for initialization of the microstep look-up table.

A quarter of a trapezoidal function or a quarter of a triangular function is chosen depending on the shape parameter σ for a given stepper motor type:

$$f_{\sigma}(\varphi) = \begin{cases} f_{\text{box_circle}}(\varphi) & \text{for } \sigma > 0 \\ f_{\text{circle}}(\varphi) & \text{for } \sigma = 0 \\ f_{\text{circle_rhomb}}(\varphi) & \text{for } \sigma < 0 \end{cases} \quad \text{with } -1.0 \leq \sigma \leq +1.0 \text{ and } 0 \leq \varphi < \frac{\pi}{2}$$

The look-up table $f(\varphi)$ of the TMC429 enfolds a quarter period ($0 \leq \varphi < \frac{\pi}{2}$) only. This quarter period is expanded to a full period ($0 \leq \varphi < 2\pi$) and the phase shifted companion function value $f\left(\varphi - \frac{\pi}{2}\right)$ is added automatically by the TMC429 during operation. So, to reach a function value $f(\varphi)$, one automatically gets a pair of function values $\{f(\varphi); f\left(\varphi - \frac{\pi}{2}\right)\}$ respectively $\{\sin(\varphi); \cos(\varphi)\}$. This automatic expansion of the TMC429 functionality – primarily provided for sine cosine microstepping $f(\varphi) = \sin(\varphi)$ – also works fine with other microstep wave forms f_{σ} .

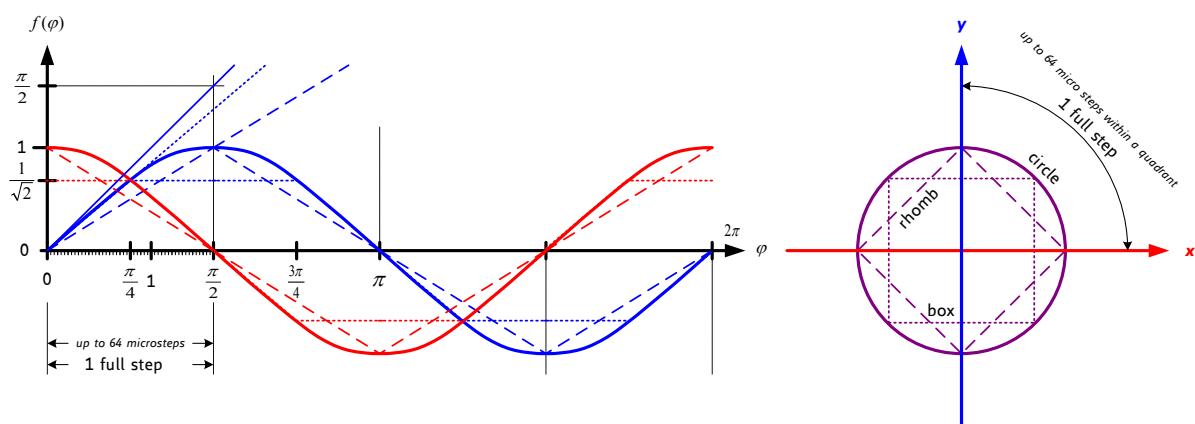

Figure 11.3 Microstep enhancement by introduction of a shape function

The shape parameter σ selects one of three functions:
(respectively a superposition of two of them)

- $f_{box}(\varphi)$
- $f_{circle}(\varphi)$
- $f_{rhomb}(\varphi)$

The shape parameter $\sigma = 0$ selects the function $f_{circle}(\varphi)$ which is the sine function $\sin(\varphi)$ as used for sine cosine microstepping. One gets the unit circle ($r=1.0$) by transformation to Cartesian coordinates $\{y = \sin(\varphi); x = \cos(\varphi)\}$ as outlined in Figure 11.3. Shape parameter $\sigma = +1.0$ results in a box. Shape parameter $\sigma = -1.0$ results in a rhomb. Other values result in something between a box and a circle respectively something between a circle and a rhomb.

The data values $y(i)$ of the look-up table range from 0 to 63 and the argument I ranges also from 0 to 63. In the following, natural angles (radians) ranging from $(0 \leq \varphi < 2\pi)$ are used for the description. The three functions for superposition controlled by the shape parameter σ are

$$f_{box}(\varphi) = \begin{cases} \frac{4}{\pi * \sqrt{2}} * \varphi & \text{if } 0 \leq \varphi < \frac{\pi}{4} \\ \frac{1}{\sqrt{2}} & \text{if } \varphi \geq \frac{\pi}{4} \end{cases}$$

$$f_{circle}(\varphi) = \sin(\varphi)$$

$$f_{rhomb}(\varphi) = \frac{2}{\pi} * \varphi$$

All together, these three functions are combined to form the function

$$f_{\sigma}(\varphi) = \begin{cases} f_{circle}(\varphi) + \sigma * [f_{box}(\varphi) - f_{circle}(\varphi)] & \text{for } \sigma > 0 \\ f_{circle}(\varphi) & \text{for } \sigma = 0 \\ f_{circle}(\varphi) + \sigma * [f_{circle}(\varphi) - f_{rhomb}(\varphi)] & \text{for } \sigma < 0 \end{cases}$$

The shape parameter σ selects the type of function and it also provides a continuous transition between circle and box respectively circle and rhomb. To estimate, what function is best for a given type of stepper motor, try microstepping based on different shape parameters σ by downloading different microstep tables on-the-fly into the TMC429 during motion of a stepper motor.

For the calculation of data for the microstep look-up table replace $\varphi \rightarrow \varphi_I$ ranging from 0 to $\pi/2$ for the quarter period by

$$\varphi_I = \frac{\pi}{2} * \frac{i}{64} \text{ with } i = \{0,1,2,3, \dots, 63\}$$

The amplitude of the shape function $f_{\sigma}(\varphi_I)$ has to be limited to the range of 0.0 to 1.0 respectively to the range of 0 to 63 for the on-chip RAM.

A fourier synthesis or an experimentally optimized wave is an option. Sometimes even a small change like a zero offset is beneficial.

12 Running a Motor

12.1 Getting Started

For starting a motor proceed as follows:

1. Write the stepper motor driver datagram configuration into the RAM area. (SPI mode only)
2. Initialize the microstep look-up table LUT when using microstepping. (SPI mode only; not necessary for TRINAMIC motor driver chips)
3. Initialize the parameter *LSMD*, which is part of the global parameter register. (SPI mode only)
4. Set the velocity parameters *V_MIN* and *V_MAX*.
5. Set the clock pre-dividers *PULSE_DIV* and *RAMP_DIV*.
6. Set the microstep resolution *USRS*.
7. Set *A_MAX* with a valid pair of *PMUL* and *PDIV*.
8. Choose the ramp mode with *RAMP_MODE* register.
9. Choose the reference switch configuration with *REF_CONF* register. The reference switch inputs REF1, REF2, and REF3 should be pulled down to ground. Use the *REF_CONF* register.
10. Now, the TMC429 runs a motor if you write either *X_TARGET* or *V_TARGET*, depending on the choice of the ramp mode.

12.2 Running a Motor with Start-Stop-Speed in *ramp_mode*

The TMC429 has an integrated automatic start-stop-speed mechanism. This can easily be realized by a simple command sequence. To start and stop with a speed *V_START_STOP* different from zero, one has to proceed as follows:

1. Set *V_MIN* := *V_START_STOP*.
2. Set *ramp_mode*.
3. Set *X_TARGET* to desired target position.
4. Set *V_ACTUAL* immediately with correct sign for *V_ACTUAL* to *+V_MIN* resp. *-V_MIN*, depending on the direction of positioning.

13 On-Chip Voltage Regulator

The on-chip voltage regulator delivers a 3.3 V supply for the chip core. The TMC429 provides two operational modes to operate in 5 V or in 3.3 V environments. For both operational modes one resp. two external capacitors are required. *Please keep all connections as short as possible!*

| OPERATIONAL MODE | |
|------------------|--|
| Operational mode | Necessary additional hardware |
| 5 V | <ul style="list-style-type: none"> - An external 100nF ceramic capacitor (CBLOCK) has to be connected between pin V5 and ground. - An external 470nF ceramic capacitor has to be connected between the V33 pin and ground. |
| 3.3 V | An external 100nF ceramic capacitor is necessary only between pin V33 and ground. |

| CHARACTERISTICS OF THE ON-CHIP VOLTAGE REGULATOR | | | | | | |
|--|---------------------|--|-----|-----|-----|--------------------|
| Symbol | Parameter | Conditions | Min | Typ | Max | Unit |
| VDD5REG | Supply voltage vdd5 | 5 V Operational Mode | 4.5 | 5 | 5.5 | V |
| CBLOCK | Block capacitor | 5 V Operational Mode, x7r ceramic capacitor | | 100 | | nF |
| VDD3REG | Supply voltage vdd3 | 3.3 V Operational Mode | 2.9 | 3.3 | 3.6 | V |
| ICCNLREG | Current consumption | No load | | 50 | 100 | μ A |
| tSREG | Startup time | No external capacitor connected | | | 20 | μ s |
| tSREGC | Startup time | C_load = 470 nF | | | 150 | μ s |
| TDRFT | Temperature drift | | | | 300 | ppm / $^{\circ}$ C |
| VRIPPLE | Ripple on vdd3 | With ripple over 50 mV the input thresholds may differ from that specified in the data sheet | | | 100 | mV |
| CREG | External capacitor | Use x7r ceramic capacitors on pin 33. Using an external capacitor with capacity other than typical, the ripple should be measured on pin v33 to be sure that requirements are satisfied. | 33 | 470 | | nF |
| COPT | Optional capacitor | Optional parallel capacitor for additional reduction of high frequency ripple, c0g ceramic, unnecessary in most cases | | 470 | | pF |

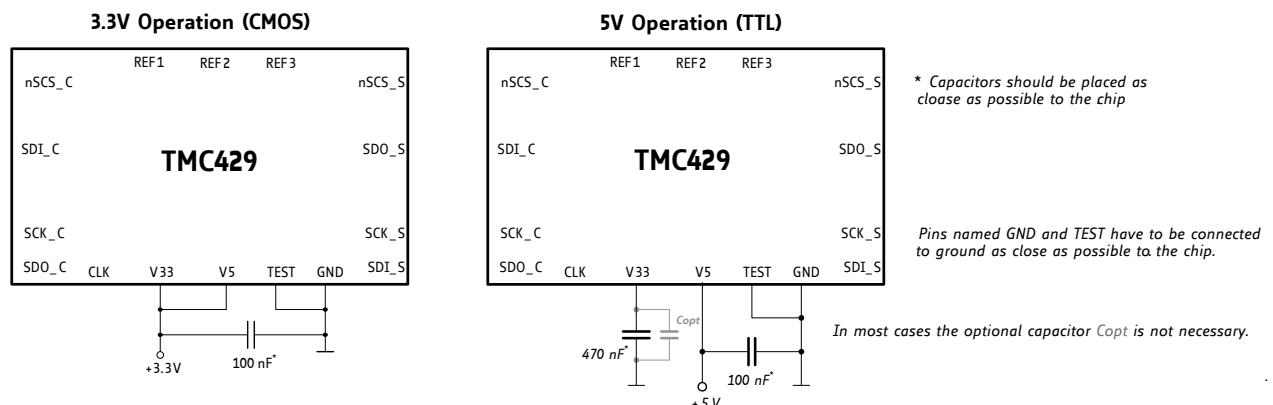

Figure 13.1 3 V operation (CMOS) vs. 5 V operation (TTL)

14 Power-On Reset

The TMC429 is equipped with a static and dynamic reset with an internal hysteresis. The chip performs an automatic reset during power-on. If the power supply voltage falls below the threshold V_{ON} , an automatic power-on reset is performed. The power-on reset time t_{RESPOR} depends on the power-up time of the on-chip voltage regulator.

| CHARACTERISTICS OF THE ON-CHIP POWER-ON-RESET | | | | | |
|---|--------------------------------------|------|------|------|---------|
| Symbol | Parameter | Min | Typ | Max | Unit |
| VDD | Power supply range | 3.0 | 3.3 | 3.6 | V |
| Temp | Temperature | -55 | 25 | 125 | °C |
| V_{OP} | Reset ON/OFF hysteresis | | | 0.80 | V |
| V_{OFF} | Reset OFF | 1.58 | 2.13 | 2.85 | V |
| V_{ON} | Reset ON | 1.49 | 1.98 | 2.70 | V |
| t_{RESPOR} | Reset time of on-chip power-on-reset | 2.14 | 3.31 | 5.52 | μ s |

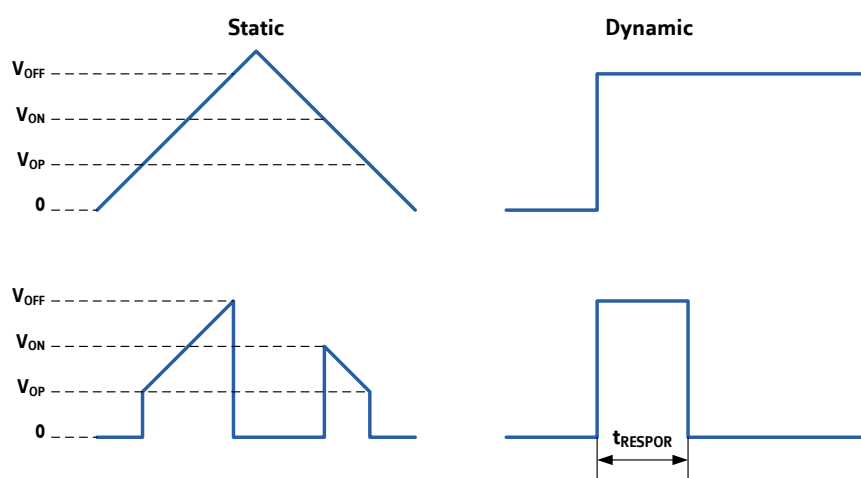

Figure 14.1 Operating principle of the power-on-reset

15 Absolute Maximum Ratings

The maximum ratings may not be exceeded under any circumstances. Operating the circuit at or near more than one maximum rating at a time for extended periods shall be avoided by application design.

| Symbol | Parameter | Conditions | Min | Max | Unit |
|--------------------|-------------------------------|---|------|---------------------------------|------|
| V _{DD3} | DC supply voltage | Voltage at Pin V33 in 3.3V mode | -0.3 | 3.6 | V |
| V _{I3} | DC input voltage, 3.3 V I/Os | | -0.3 | V _{DD3} + 0.3 | V |
| V _{O3} | DC output voltage, 3.3 V I/Os | | -0.3 | V _{DD3} + 0.3 | V |
| V _{DD5} | DC supply voltage | Voltage at Pin V5 | -0.3 | 5.5 | V |
| V _{I5} | DC input voltage, 5V I/Os | Continuous DC Voltage | -0.3 | V _{DD5} + 0.3, 5.5 max | V |
| V _{O5} | DC output voltage, 5V I/Os | Continuous DC Voltage | -0.3 | V _{DD5} + 0.3, 5.5 max | V |
| V _{ESD} | ESD voltage | PAD cells are designed to resist ESD voltages according to Human Body Model according to MIL-STD-883, with R _C = 1 – 10 MΩ, R _D = 1.5 KΩ, and C _S = 100 pF, but it cannot be guaranteed. | | ±2000 | V |
| TEMP _{D2} | Ambient air temperature range | Industrial / consumer type | -40 | +85 | °C |
| TEMP _{D3} | Ambient air temperature range | Automotive type | -55 | +125 | °C |
| TEMP _{D4} | Ambient air temperature range | Industrial type | -40 | +105 | °C |
| TSG | Storage temperature | | -60 | +150 | °C |

16 Electrical Characteristics

16.1 Power Dissipation

| General DC characteristics | | | | | | |
|----------------------------|--------------------|---|-----|------|-----|------|
| Symbol | Parameter | Conditions | Min | Typ | Max | Unit |
| I _{SC32MHZ} | Supply current | f = 32 MHz at T _c = 25°C | | 15 | | mA |
| I _{SC16MHZ} | Supply current | f = 16 MHz at T _c = 25°C | | 5 | 10 | mA |
| I _{SC8MHZ429} | Supply current | f = 8 MHz at T _c = 25°C (IOs driven) | | 5 | | mA |
| I _{SC4MHZ} | Supply current | f = 4 MHz at T _c = 25°C | | 1.25 | 2.5 | mA |
| I _{PDN25C} | Power down current | Power down mode at T _c = 25°C, 5V supply | | 70 | 150 | μA |

16.2 DC Characteristics

DC characteristics contain the spread of values guaranteed within the specified supply voltage range unless otherwise specified. A device with typical values will not leave Min/Max range within the full temperature range.

| General DC characteristics | | | | | | |
|----------------------------|-----------------------|--|------|-----|-----|------|
| Symbol | Parameter | Conditions | Min | Typ | Max | Unit |
| I _{LC} | Input leakage current | | -10 | | 10 | μA |
| C _{IN} | Input capacitance | | | 7 | | pF |
| I _L | Input with pull up | V _{IN} = 0V (REF1R, REF2R, REF3R) | -110 | -30 | -5 | μA |

| DC characteristics for 3.3V supply mode | | | | | | |
|---|------------------------------------|--------------------------|------------------------|-----|------------------------|------|
| Symbol | Parameter | Conditions | Min | Typ | Max | Unit |
| V _{DD3} | DC supply voltage | | 3.0 | 3.3 | 3.6 | V |
| V _{I3} | DC input voltage | | 0 | | V _{DD3} | V |
| V _{IL3} | Low level input voltage | Pin TEST only | 0 | | 0.3 × V _{DD3} | V |
| V _{IH3} | High level input voltage | Pin TEST only | 0.7 × V _{DD3} | | V _{DD3} + 0.3 | V |
| V _{LTH3} | Low level input voltage threshold | All inputs except TEST | 0.9 | | 1.2 | V |
| V _{HTH3} | High level input voltage threshold | All inputs except TEST | 1.5 | | 1.9 | V |
| V _{HYS3} | Schmitt-Trigger hysteresis | | 0.4 | | 0.7 | V |
| V _{OL3} | Low level output voltage | I _{OL} = 0.3 mA | | | 0.1 | V |
| V _{OH3} | High level output voltage | I _{OH} = 0.3 mA | V _{DD3} -0.1 | | | V |
| V _{OL3} | Low level output voltage | I _{OL} = 2 mA | | | 0.4 | |
| V _{OH3} | High level output voltage | I _{OH} = 2 mA | V _{DD3} -0.4 | | | V |

Ripple on V_{DD3} has to be taken into account when measuring thresholds and hysteresis.

| DC characteristics for 5V supply mode | | | | | | |
|---------------------------------------|------------------------------------|--|------------------------|-----|------------------------|------|
| Symbol | Parameter | Conditions | Min | Typ | Max | Unit |
| V _{DD5} | DC supply voltage | | 4.5 | 5 | 5.5 | V |
| V _{I5} | DC input voltage | | 0 | | V _{DD5} | V |
| V _{IL5} | Low level input voltage | Pin TEST only | 0 | | 0.3 × V _{DD5} | V |
| V _{IH5} | High level input voltage | Pin TEST only | 0.7 × V _{DD5} | | V _{DD5} + 0.3 | V |
| V _{LTH5} | Low level input voltage threshold | All inputs except TEST, V _{DD5} =5V | 0.9 | | 1.2 | V |
| V _{HTH5} | High level input voltage threshold | All inputs except TEST, V _{DD5} =5V | 1.5 | | 1.9 | V |
| V _{HYS5} | Schmitt-Trigger hysteresis | | 0.4 | | 0.7 | V |
| V _{OL5} | Low level output voltage | I _{OL} = 0.3 mA | | | 0.1 | V |
| V _{OH5} | High level output voltage | I _{OH} = 0.3 mA | V _{DD5} -0.1 | | | V |
| V _{OL5} | Low level output voltage | I _{OL} = 4 mA | | | 0.4 | |
| V _{OH5} | High level output voltage | I _{OH} = 4 mA | V _{DD5} -0.4 | | | V |

16.3 Timing Characteristics

| General timing parameters (TMC429 with EMI optimized output drivers) | | | | | | |
|--|-------------------------|--|-------|-----|----------|------|
| Symbol | Parameter | Conditions | Min | Typ | Max | Unit |
| f_{CLK} | Operation frequency | $f_{CLK} = 1 / t_{CLK}$ | 0 | 16 | 32 | MHz |
| t_{CLK} | Clock period | Rising edge to rising edge of CLK | 31.25 | | ∞ | ns |
| t_{CLK_L} | Clock time low | | 12.5 | | ∞ | ns |
| t_{CLK_H} | Clock time high | | 12.5 | | ∞ | ns |
| t_{RISE_I} | Input signal rise time | 10% to 90% except TEST pin | 0.5 | | ∞ | ns |
| t_{FALL_I} | Input signal fall time | 90% to 10% except TEST pin | 0.5 | | ∞ | ns |
| $t_{RISE_O_429}$ | Output signal rise time | 10% to 90% | | 7 | | ns |
| $t_{FALL_O_429}$ | Output signal fall time | 90% to 10% | | 7 | | ns |
| t_{SU} | Setup time | Relative to falling clock edge at CLK | 1 | | | ns |
| t_{HD} | Hold time | Relative to falling clock edge at CLK | 1 | | | ns |
| t_{PD_429} | Propagation delay time | 50% of rising edge of the clock CLK to the 50% of the output | 1 | 10 | | ns |

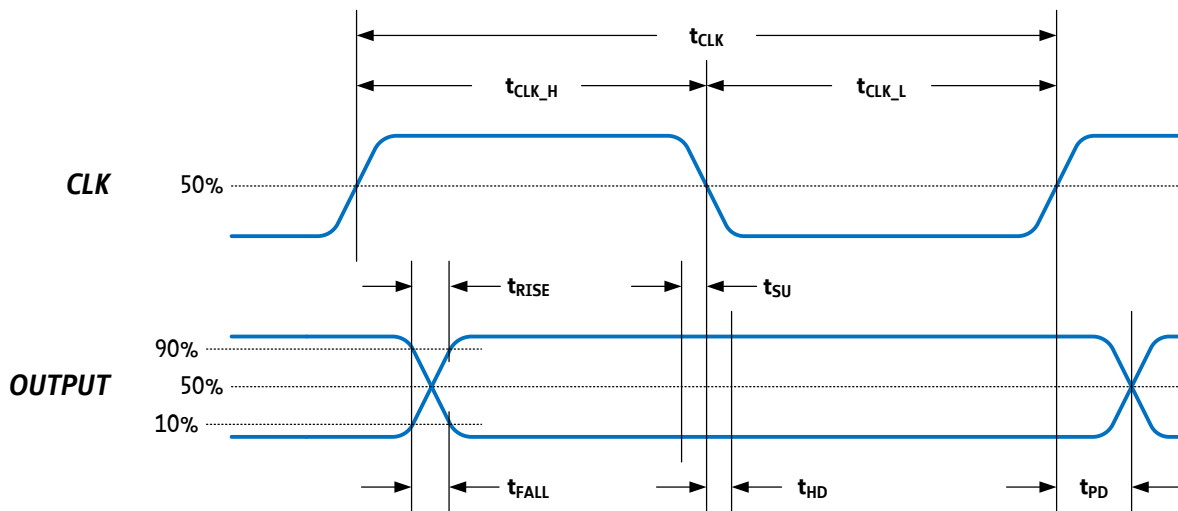

Figure 16.1 General timing parameters

18 Package Mechanical Data

The TMC429 is available within three packages: QFN32, SOP24, and SSOP16

18.1 TMC429-LI / QFN32

18.1.1 Dimensional Drawings

Attention: Drawings not to scale.

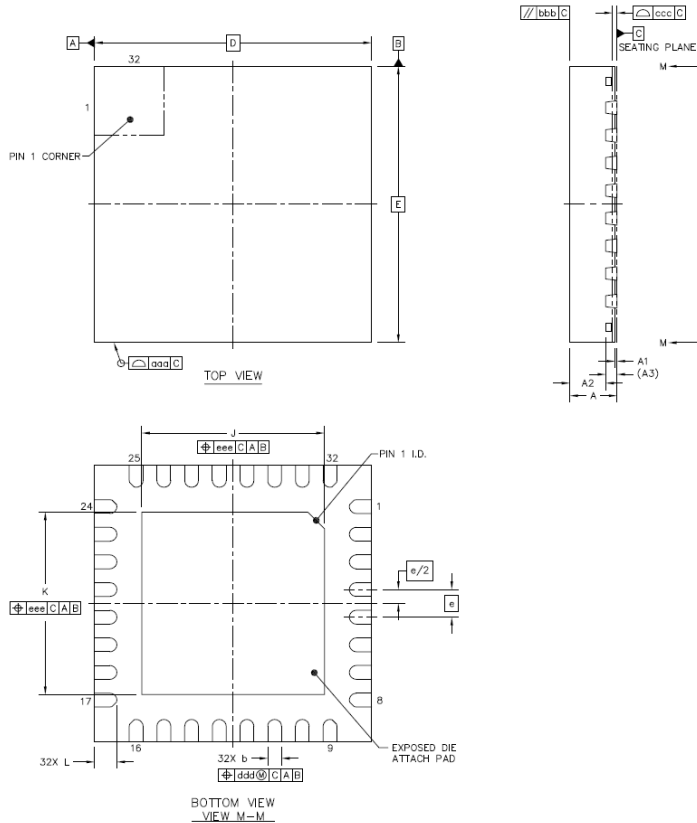

Figure 18.1 Dimensional drawings of QFN32

| DIMENSIONS OF PACKAGE QFN32 | | | | |
|-----------------------------|-----|------|-------|------|
| Parameter | Ref | Min | Nom | Max |
| Total thickness | A | 0.80 | 0.85 | 0.90 |
| Standoff | A1 | 0.00 | 0.035 | 0.05 |
| Mold thickness | A2 | - | 0.65 | 0.67 |
| Lead frame thickness | A3 | | 0.203 | |
| Lead width | b | 0.2 | 0.25 | 0.3 |
| Body size X | D | | 5.0 | |
| Body size Y | E | | 5.0 | |
| Lead pitch | e | | 0.5 | |
| Exposed die pad size X | J | 3.2 | 3.3 | 3.4 |
| Exposed die pad size Y | K | 3.2 | 3.3 | 3.4 |
| Lead length | L | 0.35 | 0.4 | 0.45 |
| Package edge tolerance | aaa | | | 0.1 |
| Mold flatness | bbb | | | 0.1 |
| Coplanarity | ccc | | | 0.08 |
| Lead offset | ddd | | | 0.1 |
| Exposed pad offset | eee | | | 0.1 |

18.1.2 Package Code

| Device | Package | Temperature range | Code/ Marking |
|--------|--------------|-------------------|---------------|
| TMC429 | QFN32 (RoHS) | -40° to +105°C | TMC429-LI |

18.2 TMC429-PI24 / SOP24

18.2.1 Dimensional Drawings

Attention: Drawings not to scale.

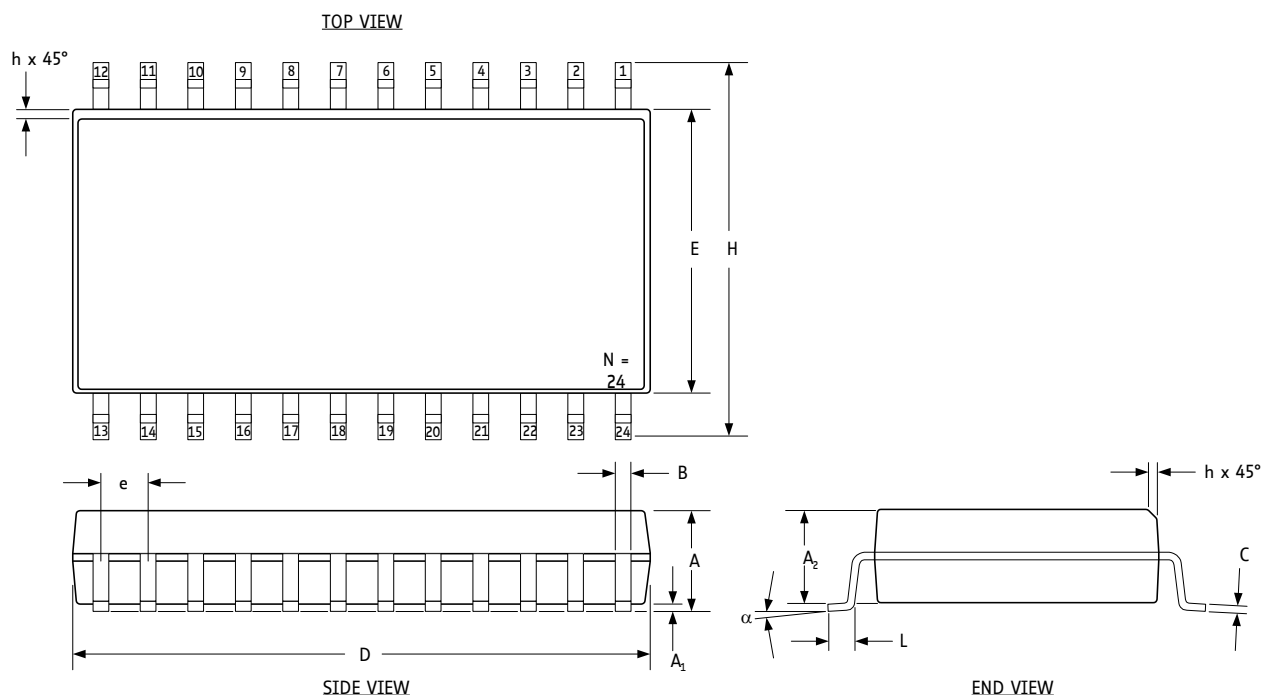

Figure 18.2 Dimensional drawings SOP24, 300 MILS

| DIMENSIONS OF PACKAGE SOP24, 300 MILS | | | | | | |
|---------------------------------------|---------------------------|-----|-------|----------------------|-----|--------|
| Symbol | Dimensions in MILLIMETERS | | | Dimensions in INCHES | | |
| | Min | Typ | Max | Min | Typ | Max |
| A | 2.35 | | 2.65 | 0.0926 | | 0.1043 |
| A1 | 0.1 | | 0.3 | 0.004 | | 0.0118 |
| A2 | | | | | | |
| B | 0.33 | | 0.51 | 0.013 | | 0.02 |
| C | 0.23 | | 0.32 | 0.0091 | | 0.0125 |
| D | 15.2 | | 15.6 | 0.5985 | | 0.6141 |
| E | 7.4 | | 7.6 | 0.2914 | | 0.2992 |
| e | 1.27 best case | | | 0.05 best case | | |
| H | 10 | | 10.65 | 0.394 | | 0.419 |
| h | 0.25 | | 0.75 | 0.01 | | 0.029 |
| L | 0.4 | | 1.27 | 0.016 | | 0.05 |
| N | 24 | | | 24 | | |
| α | 0° | | 8° | 0° | | 8° |

18.2.2 Package Code

| Device | Package | Temperature range | Code/ Marking |
|--------|--------------|-------------------|---------------|
| TMC429 | SOP24 (RoHS) | -40° to +105°C | TMC429-PI24 |

18.4 TMC429-I / SSOP16

18.4.1 Dimensional Drawings

Attention: Drawings not to scale.

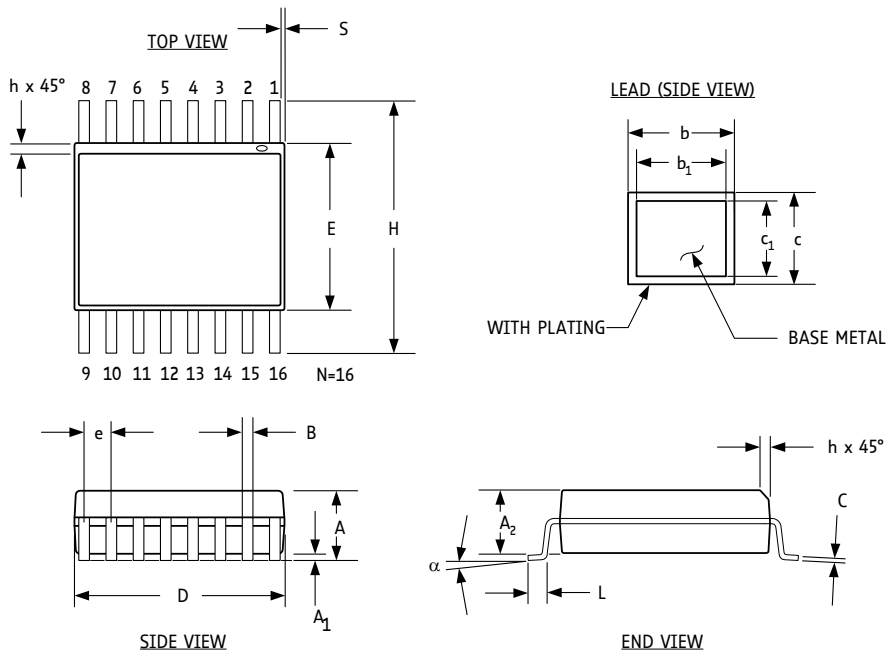

Figure 18.3 Dimensional drawings SSOP16, 150 MILS, 0.635mm (0.025 inch) pitch

| DIMENSIONS OF PACKAGE SSOP16, 150 MILS | | | | | | |
|--|---------------------------|-------|-------|----------------------|--------|--------|
| Symbol | Dimensions in MILLIMETERS | | | Dimensions in INCHES | | |
| | Min | Typ | Max | Min | Typ | Max |
| A | 1.55 | 1.63 | 1.73 | 0.061 | 0.064 | 0.068 |
| A1 | 0.10 | 0.15 | 0.25 | 0.004 | 0.006 | 0.0098 |
| A2 | 1.40 | 1.47 | 1.55 | 0.055 | 0.058 | 0.061 |
| b | 0.20 | | 0.30 | 0.008 | | 0.012 |
| b1 | 0.20 | 0.25 | 0.28 | 0.008 | 0.010 | 0.011 |
| c | 0.18 | | 0.25 | 0.007 | | 0.010 |
| c1 | 0.18 | 0.20 | 0.23 | 0.007 | 0.008 | 0.009 |
| B | 0.20 | 0.25 | 0.31 | 0.008 | 0.010 | 0.012 |
| C | 0.19 | 0.20 | 0.25 | 0.0075 | 0.008 | 0.0098 |
| D | 4.80 | 4.93 | 4.98 | 0.189 | 0.194 | 0.196 |
| E | 3.91 best case | | | 0.154 best case | | |
| e | 0.635 best case | | | 0.025 best case | | |
| H | 6.02 best case | | | 0.237 best case | | |
| h | 0.25 | 0.33 | 0.41 | 0.010 | 0.013 | 0.016 |
| L | 0.41 | 0.635 | 0.89 | 0.016 | 0.025 | 0.035 |
| N | 16 | | | 16 | | |
| S | 0.051 | 0.114 | 0.178 | 0.0020 | 0.0045 | 0.0070 |
| α | 0° | 5° | 8° | 0° | 5° | 8° |

18.4.2 Package Code

| Device | Package | Temperature range | Code/ Marking |
|--------|---------------|-------------------|---------------|
| TMC429 | SSOP16 (RoHS) | -40° to +105°C | TMC429-I |

19 Marking

| | |
|------------------------------|---|
| PRODUCT NAME | TMC429-I |
| Package | SSOP16 – 150 MILS |
| Date code | WWYY (week WW and year YY) |
| Lot number identifier | LLLL |
| Logo | No |
| <i>Zoomed Size</i> |  |

| | |
|------------------------------|--|
| PRODUCT NAME | TMC429-LI |
| Package | QFN32 5mm * 5mm |
| Date code | WWYY (week WW and year YY) |
| Lot number identifier | LLLL |
| Logo | Yes |
| <i>Zoomed Size</i> |  |

| | |
|------------------------------|--|
| PRODUCT NAME | TMC429-PI24 |
| Package | SOP24 – 300 MILS |
| Date code | WWYY (week WW and year YY) |
| Lot number identifier | LLLL |
| Logo | Yes |
| <i>Zoomed Size</i> |  |

20 Compatibility Information: TMC429 and TMC428

The TMC429 is the 100% functional and pin compatible successor of the TMC428. The TMC429 can replace a TMC428 in existing hardware / software environments.

There are some additional functions of the TMC429 which are mapped in register address ranges that were indicated reserved addresses for later versions. When these additional registers of the TMC429 are not accessed, the TMC429 behaves identically as a TMC428. Registers, which are added in the TMC429, are labeled with `_429` (e.g. register `if_configuration_429`).

The TMC429 has a step/direction interface that perfectly fits to the TRINAMIC stepper motor driver family TMC260, TMC261, and TMC262.

The TMC429 has a higher clock frequency range than the TMC428:

- The TMC428 can be clocked up to 16MHz.
- The TMC429 can be clocked with up to 32MHz.

20.1 Signal Descriptions: TMC428 vs. TMC429

Please note, that the STEP/DIR interface of the TMC429 is not mentioned in this section because elder TMC428 applications always use SPI interface. All pin functions necessary for replacing the TMC428 by the TMC429 are described in this table.

| Pin TMC429 Pin TMC428 | SSOP16 | SOP24 TMC428 | SOP24 TMC429 | In/Out | Description |
|----------------------------|--------|-----------------|-----------------|--------|--|
| Reset | - | - | - | - | Internal power-on reset |
| CLK | 5 | 7 | 7 | I | Clock input |
| nSCS_C | 6 | 9 | 9 | I | Low active SPI chip select input driven from μ C |
| SCK_C | 7 | 10 | 10 | I | Serial data clock input driven from μ C |
| SDI_C | 8 | 11 | 11 | I | Serial data input driven from μ C |
| nINT_SDO_C SDO_C / nINT | 9 | 14 | 14 | O | Serial data output to μ C input / multiplexed nINTERRUPT output if communication with μ C is idle (resp. nSCS_C = 1) SDO_C will never be high impedance, but this function can be added with a single gate 74HCT1G125 (see Figure 20.1). The TMC429 is equipped with an additional pin named SDOZ_C which becomes high impedance when nSCS_C=1. |
| nSCS_S_S2 nSCS_S | 12 | 17 | 17 | O | SPI chip select signal to stepper motor driving chain |
| nSCS2_S3 nSCS2 | - | 18 | 18 | O | SPI chip select signal |
| nSCS3_D3 nSCS3 | - | 19 | 19 | O | SPI chip select signal |
| SCK_S_D1 SCK_S | 11 | 16 | 16 | O | Serial data clock output to SPI stepper motor driver chain |
| SDO_S_S1 SDO_S | 10 | 15 | 15 | O | Serial data output to SPI stepper motor driver chain |
| SDI_S_D2 SDI_S | 16 | 23 | 23 | I | Serial data input from SPI stepper motor driver chain (pull-up/down resistor at SDI_S avoids high impedance; SDI_S input is the power-on default) |
| REF1 | 1 | 2 | 2 | I | Reference switch input 1 No internal pull-up R |
| REF2 | 2 | 3 | 3 | I | Reference switch input 2 No internal pull-up R |
| REF3 | 3 | 4 | 4 | I | Reference switch input 3 No internal pull-up R |
| V5 | 13 | 5, 20 | 5, 20 | | +5V supply / +3.3V supply |
| V33 | 14 | 21 | 21 | | 470nF ceramic capacitor pin / +3.3V supply |
| GND | 15 | 8, 22 | 8, 22 | | Ground |

| Pin TMC429 Pin TMC428 | SSOP16 | SOP24 TMC428 | SOP24 TMC429 | In/Out | Description |
|--------------------------|--------|------------------|-----------------|----------|---|
| TEST | 4 | 6 | 6 | I | Must be connected to GND as close as possible to the chip |
| n.c. | - | 1, 12, 13, 24 | - | - | Not connected pins |
| POSCMP n.c. | - | n.c. | 1 | n.c. / O | Position compare output for SOP24 / output for pos_comp function (TMC429 only) |
| SDOZ_C | - | n.c. | 12 | O / Z | SDOZ_C becomes high impedance (Z) when nSCS_C=1 / The nINT signal is not mapped to SDOZ_C pin / The TMC429 provides a register for configuration of the pin nINT_SDO_C to give the nINT signal directly without multiplexing. |
| REFR1 | - | n.c. | 24 | I | Reference switch right 1 input Only available for TMC429 in SOP24 package; internal pull-up R |
| REFR2 | - | n.c. | 13 | I | Reference switch right 2 input Only available for TMC429 in SOP24 package; internal pull-up R |

Note

When replacing a TMC428 in SOP24 package by a TMC429 in SOP24 package on an existing PCB make sure that the pins 1 and 12 are not connected on the PCB. These pins are outputs for the TMC429 in SOP24 package.

The TMC428-I in SSOP16 can be replaced by a TMC429-I without restrictions.

20.2 TMC428 SDO_C Output

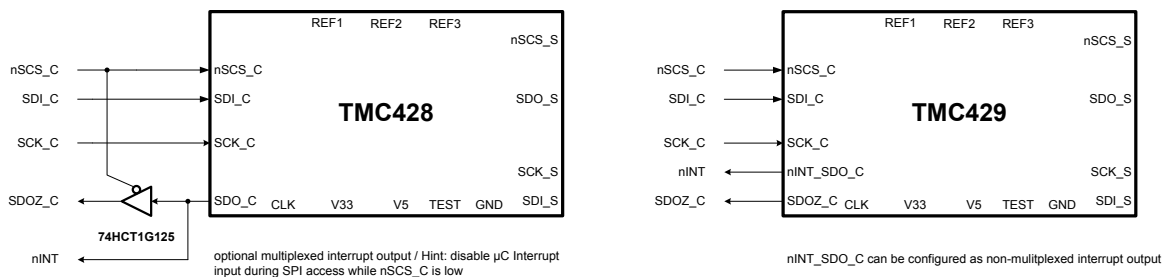

Figure 20.1 TMC428 SDO_C tristate output using a single gate 74HCT1G125. The TMC429 has a dedicated tristate output (SDOZ_C). nINT_SDO_C can be switched to nINT.

20.3 Unused Addresses

20.3.1 Unused Address (IDX=%1111)

Reading the register gives back the actual status bits and 24 data bits set to 0. Writing to this register has no effect for the TMC428. This register address (IDX=%1111) within each stepper motor register block {SMDA=%00, %01, %10} is unused for the TMC428.

20.3.2 Unused Addresses (JDX={%0100, %0101, %0110, %1001})

There are unused addresses within the address range of the global parameter registers. Access to these addresses has no effect for the TMC428. However, access should be avoided, because this address space may be used for future devices. For the TMC429, the global registers at addresses JDX={%0100, %0101, %0110, %1001} are used for TMC429 specific function. Some bits of the clk2_div (JDX=%1111) are used for the timing configuration in step/direction mode of the TMC429.

For the TMC429 some of the un-used addresses are used for additional registers of the TMC429. Additional registers of the TMC429 are named as <NAME>_429 to indicate that these have TMC429 specific functions that are not available for the TMC428.

20.4 General Timing Parameters

The TMC429 has improved values when compared to TMC428. In this table modified timing values are summarized.

| General timing parameters (TMC428 with EMI optimized output drivers) | | | | | | |
|--|-------------------------|--|-------|-----|-----|------|
| Symbol | Parameter | Conditions | Min | Typ | Max | Unit |
| f _{CLK} | Operation frequency | f _{CLK} = 1 / t _{CLK} | 0 | 16 | 32 | MHz |
| t _{CLK} | Clock period | Raising edge to rising edge of CLK | 31.25 | | ∞ | ns |
| t _{CLK_L} | Clock time low | | 12.5 | | ∞ | ns |
| t _{CLK_H} | Clock time high | | 12.5 | | ∞ | ns |
| t _{RISE_I} | Input signal rise time | 10% to 90% except TEST pin | 0.5 | | ∞ | ns |
| t _{FALL_I} | Input signal fall time | 90% to 10% except TEST pin | 0.5 | | ∞ | ns |
| t _{RISE_O_428} | Output signal rise time | 10% to 90% | | 3 | | ns |
| t _{FALL_O_428} | Output signal fall time | 90% to 10% | | 3 | | ns |
| t _{SU} | Setup time | Relative to falling clock edge at CLK | 1 | | | ns |
| t _{HD} | Hold time | Relative to falling clock edge at CLK | 1 | | | ns |
| t _{PD_428} | Propagation delay time | 50% of rising edge of the clock CLK to the 50% of the output | 1 | 5 | | ns |

21 Disclaimer

TRINAMIC Motion Control GmbH & Co. KG does not authorize or warrant any of its products for use in life support systems, without the specific written consent of TRINAMIC Motion Control GmbH & Co. KG. Life support systems are equipment intended to support or sustain life, and whose failure to perform, when properly used in accordance with instructions provided, can be reasonably expected to result in personal injury or death.

Information given in this data sheet is believed to be accurate and reliable. However no responsibility is assumed for the consequences of its use nor for any infringement of patents or other rights of third parties which may result from its use.

Specifications are subject to change without notice.

All trademarks used are property of their respective owners.

22 ESD Sensitive Device

The TMC429 is an ESD-sensitive CMOS device and sensitive to electrostatic discharge. Take special care to use adequate grounding of personnel and machines in manual handling. After soldering the devices to the board, ESD requirements are more relaxed. Failure to do so can result in defects or decreased reliability.

PAD cells are designed to resist ESD voltages corresponding to Human Body Model (MIL-STD-883, with $R_C = 1 - 10 \text{ M}\Omega$, $R_D = 1.5 \text{ K}\Omega$, and $C_S = 100 \text{ pF}$).



Note: In a modern SMD manufacturing process, ESD voltages well below 100V are standard. A major source for ESD is hot-plugging the motor during operation.

23 Table of Figures

| | |
|---|----|
| Figure 1.1 TMC429 functional block diagram..... | 4 |
| Figure 1.2 Application example using Step/Dir driver interface | 5 |
| Figure 1.3 Application example using SPI driver interface | 5 |
| Figure 4.1 TMC429 pin out | 11 |
| Figure 5.1 TMC429 within QFN32 package..... | 13 |
| Figure 5.2 TMC429 / TMC26x outline for configuration via SPI and STEP/DIR for motion..... | 13 |
| Figure 5.3 TMC429 application environment with TMC429 in SSOP16 package..... | 14 |
| Figure 5.4 Usage of drivers without serial data output (SDO) with TMC429 in SOP24 or in QFN32 packages | 14 |
| Figure 6.1 Timing diagram of the serial μ C interface..... | 16 |
| Figure 6.2 The TMC429 has a high impedance pin SDO _{Z_C} . The nINT_SDO_C can be configured as non multiplexed interrupt output nINT if required..... | 17 |
| Figure 8.1 Velocity ramp parameters and velocity profiles..... | 24 |
| Figure 8.2 Target position calculation, ramp generator, and pulse generator..... | 28 |
| Figure 8.3 Proportionality parameter p and outline of velocity profile(s)..... | 30 |
| Figure 8.4 Left switch and right switch for reference search and automatic stop function | 33 |
| Figure 8.5 Example of status bit mapping for a chain of three TMC246 or TMC249..... | 40 |
| Figure 8.6 Cover datagram example with 7 bits covering 7 bits of a 48 bit datagram..... | 41 |
| Figure 9.1 TMC429-LI has three right reference inputs. TMC429-PI24 has two right reference inputs..... | 49 |
| Figure 9.2 Reference switch configuration <i>left-side-only</i> for $mot1r=0$ (and $refmux=0$) | 50 |
| Figure 9.3 Reference switch configuration <i>two-one-zero</i> for $mot1r=1$ (and $refmux=0$)..... | 50 |
| Figure 9.4 Reference switch multiplexing with 74HC157 ($refmux=1$)..... | 51 |
| Figure 9.5 Triple switch configuration <i>left stop switch – reference switch – right stop switch</i> | 51 |
| Figure 9.6 Reference search | 52 |
| Figure 9.7 Reference switch gating for exact simultaneous stepper motor start..... | 52 |
| Figure 10.1 Step/Dir timing ($en_sd = 1$; $step_half = 0$)..... | 53 |
| Figure 11.1 Timing diagram of the serial stepper motor driver interface..... | 54 |
| Figure 11.2 Serially transmitted control and status signals between TMC429 and driver chain..... | 58 |
| Figure 11.3 Microstep enhancement by introduction of a shape function | 65 |
| Figure 13.1 3 V operation (CMOS) vs. 5 V operation (TTL) | 68 |
| Figure 14.1 Operating principle of the power-on-reset..... | 69 |
| Figure 16.1 General timing parameters..... | 72 |
| Figure 18.1 Dimensional drawings of QFN32..... | 73 |
| Figure 18.2 Dimensional drawings SOP24, 300 MILS..... | 74 |
| Figure 18.3 Dimensional drawings SSOP16, 150 MILS, 0.635mm (0.025 inch) pitch..... | 75 |
| Figure 20.1 TMC428 SDO_C tristate output using a single gate 74HCT1G125. The TMC429 has a dedicated tristate output (SDO _{Z_C}). nINT_SDO_C can be switched to nINT. | 78 |

24 Revision History

| Version | Date | Author LL - Lars Larsson BD - Bernhard Dwersteg SD - Sonja Dwersteg | Description |
|---------|--------------|--|--|
| 1.00 | 2009-DEC-08 | LL | <ul style="list-style-type: none"> - TMC429 Datasheet Rev. 1.00 based on TMC428 Datasheet Rev. 2.03 / December 18, 2009. - Corrections: $p = a_max / (128 * 2^{(pulse_div - ramp_div) })$ $p = a_max / (128 * 2^{(ramp_div - pulse_div) });$ |
| | 2010-MAY-05 | LL | <ul style="list-style-type: none"> - QFN32 package pinning added. - Hint added concerning changing of pulse_div while VELOCITY_MODE or HOLD_MODE that might force an internal step pulse depending on the current position. - DIL20 package of TMC428 removed. |
| | 2010-AUG-05 | LL | <ul style="list-style-type: none"> - Pin out GND @ 25 and n.c. @ 32 added for QFN32 package. - Pinning table updated with TMC428 SOP24 package variant. - Hints added for new functions of the TMC429. - Section 20.3 Unused Addresses - Unused Address (IDX=%1111) , p. 78 and section 8.1.16 USTEP_COUNT_429 (IDX=%1111) modified / added because this register was unused for the TMC428 but is a read / write register for the TMC429. |
| | 2010-AUG-26) | LL | <ul style="list-style-type: none"> - SDO_C renamed to iINT_SDC_C at package drawings. - SPI configuration outline added. |
| | 2010-SEP-10 | LL | <ul style="list-style-type: none"> - Figure 20.1 TMC428 SDO_C tristate output using a single gate 74HCT1G125. The TMC429 has a dedicated tristate output (SDOZ_C). nINT_SDO_C can be switched to nINT. - Description of if_Configuration_429 finalized. - Step/direction timing figure and description added (section 10 Step/Dir , page 53). - Short description of differences between TMC428 vs. TMC429. - Section 12.2 Running a Motor with Start-Stop-Speed in ramp_mode, page 67 new. |
| 1.01 | 2010-OCT-10 | LL | <ul style="list-style-type: none"> - Marking (section 19, p. 76) updated. - Timing parameter updated |
| 1.02 | 2010-NOV-01 | LL | Pinning of SSOP16 (pin 10) package variant corrected. |
| 1.03 | 2010-NOV-05 | LL | <ul style="list-style-type: none"> - TMC428 drawings (Figure 20.1, Figure 9.2, Figure 9.3, Figure 9.1, Figure 9.4, Figure 9.7) updated concerning TMC428 / TMC429. - Feature list updated concerning step direction interface; |
| 1.04 | 2010-NOV-11 | LL | <ul style="list-style-type: none"> - Section 10 Step/Dir , page 53 equation tSTEP[μs] corrected. |
| 1.05 | 2010-DEC-06 | LL | <ul style="list-style-type: none"> - Position compare control register (pos_comp) and associated output poscmp labelling unified. - TMC428 changed to TMC429 in text if necessary. |
| | 2011-APR-06 | LL | <ul style="list-style-type: none"> - Preliminary removed and version date updated; no changes within the document itself. |
| | 2011-MAY-17 | | <ul style="list-style-type: none"> - Hint concerning microstep frequency added in section 10, p. 53. |
| | 2011-AUG-02 | | <ul style="list-style-type: none"> - Post address updated. - Hint concerning current scaling at rest added. - Typical current ISC32MHZ added and symbol ISC4MHZ429 corrected/changed to ISC8MHZ429. |
| | 2011-DEC-15 | | <ul style="list-style-type: none"> - Power-on default initialization of the SPI driver chain for |

| Version | Date | Author LL - Lars Larsson BD - Bernhard Dwersteg SD - Sonja Dwersteg | Description |
|---------|---|--|--|
| | 2012-JAN-19 | | TMC236/TMC239/TMC246/TMC249 SPI stepper motor chain updated. - TMC429 power-on reset (POR) default values added. - Hint concerning power-on defaults of sine wave table added. |
| 1.06 | 2012-JAN-27 2012-MAR-28 2012-MAY-22 | LL | - Section 12.2 Running a Motor with Start-Stop-Speed in ramp_mode item set X_TARGET := V_START_STOP corrected to set X_TARGET to desired position. Initialization of On-Chip RAM by μ C after Power-On updated. - Hint concerning frequency of SPI clock SCK relative to TMC429 clock fCLK added. - Updated concerning dimensioning drawing at rising edge of direction signal (signal shape itself was correct). |
| 1.07 | 2012-AUG-01 | SD | - Section 0 corrected: smda 0100. |
| 2.00 | 2012-DEC-03 | SD | Amended datasheet version with new design. Several changes. |
| 2.01 | 2012-DEC-18 | JP | General DC characteristics changed |
| 2.02 | 2013-NOV-04 | SD | - Application example in chapter 5.2 updated. - USTEP_COUNT_429 description updated - Value ranges for X_TARGET and X_ACTUAL updated (signed and unsigned are possible). - Chapter 1.2.1 (serial μ C interface) corrected. |
| 2.03 | 2015-MAR-10 | BD | - A_ACTUAL is signed, 12 bit (p. 22) |
| 2.04 | 2015-JUN-03 | BD | Corrected meaning of RS bits in SPI status information field |

25 References

[TMC429+26x-EVAL] TMC429+26x-EVAL Manual / Evaluation board for S/D chipset (TMC429with TMC260, TMC261, TMC262 and TMC424)

[TMC429+TMC24x-EVAL] TMC429+TMC24x-EVAL Manual / Evaluation board for SPI chipset (TMC429, TMC246, and TMC249)

Looking for pricing, stock, or lifecycle information?

Click below to explore more details on WIN SOURCE:

- ⊖ [View TMC429-I on WIN SOURCE](#)
- ⊖ [Trinamic Motion Control GmbH Information](#)

Optimize Your Supply Chain with WIN SOURCE Solutions

- ✓ Global Sourcing Solution
- ✓ Obsolete Management
- ✓ Cost Control Management
- ✓ Shortage Management
- ✓ Alternative Solution
- ✓ Excess Inventory Management