



**THE DATASHEET OF
100395QC**



100395 Low Power 9-Bit ECL-to-TTL Translator with Registers

General Description

The 100395 is a 9-bit translator for converting F100K logic levels to TTL logic levels. A HIGH on the output enable (\overline{OE}) holds the TTL outputs in a high impedance state. Two separate clock inputs are available for multiplexing and system level testing.

The 100395 is designed with TTL 64 mA outputs for bus driving capability. All inputs have 50 k Ω pull down resistors. When the inputs are either unconnected or at the same potential, the outputs will go LOW.

Features

- 64 mA I_{OL} drive capability
- 2000V ESD protection
- -4.2V to -5.7V operating range
- Registered outputs
- TTL outputs

Ordering Code:

Order Number	Package Number	Package Description
100395QC	V28A	28-Lead Plastic Lead Chip Carrier (PLCC), JEDEC MO-047, 0.450 Square

Devices also available in Tape and Reel. Specify by appending the suffix letter "X" to the ordering code.

Logic Symbol

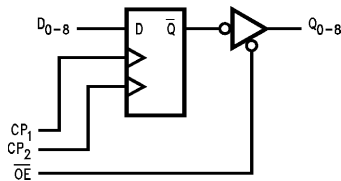

Connection Diagram

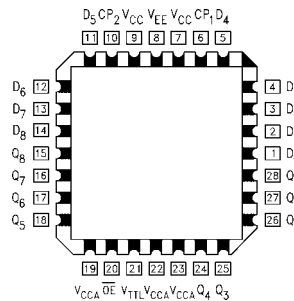

Pin Descriptions

Pin Names	Description
D_0 - D_8	Data Inputs (ECL)
Q_0 - Q_8	Data Outputs (TTL)
\overline{OE}	Output Enable (ECL)
CP_1, CP_2	Clock Inputs (ECL)

Truth Table

Inputs				Outputs
CP_1	CP_2	\overline{OE}	D_N	Q_N
↗	L	L	L	L
L	↗	L	L	L
↗	L	L	H	H
L	↗	L	H	H
H	X	X	X	NC
X	H	X	X	NC
L	L	X	X	NC
X	X	H	X	Z

H = HIGH Voltage Level
L = LOW Voltage Level
X = Don't Care

Z = High Impedance
NC = No Change

100395

Logic Diagram

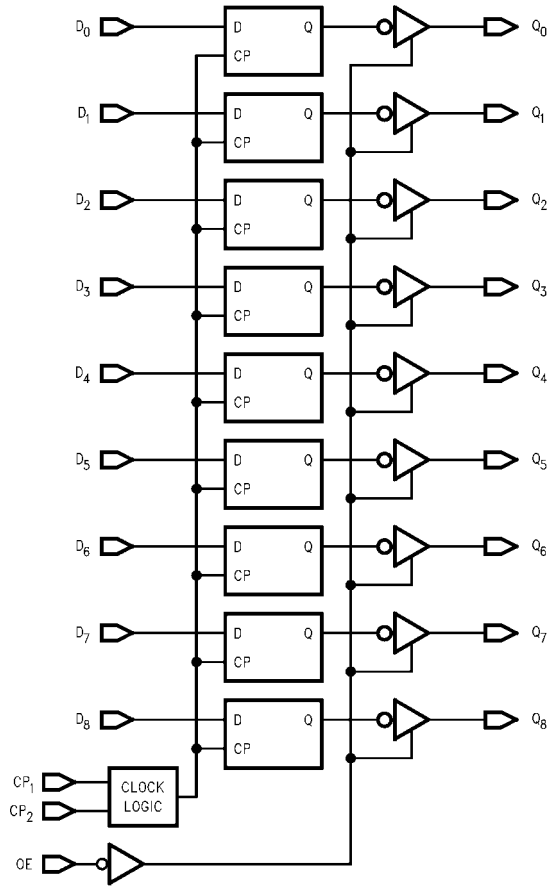

Absolute Maximum Ratings(Note 1)

Storage Temperature (T_{STG})	-65°C to +150°C
Maximum Junction Temperature (T_J)	+150°C
Case Temperature under Bias (T_C)	0°C to +85°C
V_{EE} Pin Potential to Ground Pin	-7.0V to +0.5V
V_{TTL} Pin Potential to Ground Pin	-0.5V to +6.0V
ECL Input Voltage (DC)	V_{EE} to +0.5V
TTL Input Voltage	-0.5V to +7.0V
Output Current	
(DC Output HIGH)	+130 mA
ESD (Note 2)	≥ 2000V

Recommended Operating Conditions

Case Temperature (T_C)	0°C to +85°C
Supply Voltage	
V_{EE}	-5.7V to -4.2V
V_{TTL}	+4.5V to +5.5V

Note 1: The "Absolute Maximum Ratings" are those values beyond which the safety of the device cannot be guaranteed. The device should not be operated at these limits. The parametric values defined in the Electrical Characteristics tables are not guaranteed at the absolute maximum rating. The "Recommended Operating Conditions" table will define the conditions for actual device operation.

Note 2: ESD testing conforms to MIL-STD-883, Method 3015.

Commercial Version**DC Electrical Characteristics** (Note 3)

$V_{EE} = -4.2V$ to $-5.7V$, $V_{CC} = V_{CCA} = GND$, $T_C = 0°C$ to $+85°C$

Symbol	Parameter	Min	Typ	Max	Units	Conditions
V_{OH}	Output HIGH Voltage	2.4			V	$I_{OH} = -15$ mA $V_{IN} = V_{IH}$ (Max)
V_{OL}	Output LOW Voltage			0.55	V	$I_{OL} = 64$ mA or V_{IL} (Min)
V_{IH}	Input HIGH Voltage	-1165		-870	mV	Guaranteed HIGH Signal for All Inputs
V_{IL}	Input LOW Voltage	-1830		-1475	mV	Guaranteed LOW Signal for All Inputs
I_{IL}	Input LOW Current	0.5			μA	$V_{IN} = V_{IL}$ (Min)
I_{IH}	Input HIGH Current			240	μA	$V_{IN} = V_{IH}$ (Max)
I_{OZL}	3-STATE Current Output HIGH			-50	μA	$V_{OUT} = +0.4V$
I_{OZH}	3-STATE Current Output LOW			+50	μA	$V_{OUT} = +2.7V$
I_{CEX}	Output HIGH Leakage Current			250	μA	$V_{OUT} = V_{CC}$
I_{OS}	Output Short-Circuit Current	-100		-225	mA	
I_{EE}	V_{EE} Power Supply Current	-67		-29	mA	Inputs OPEN
I_{CCH}	V_{TTL} Power Supply Current HIGH			29	mA	
I_{CCL}	V_{TTL} Power Supply Current LOW			65	mA	
I_{CCZ}	V_{TTL} Power Supply Current 3-STATE			49	mA	

Note 3: The specified limits represent the "worst case" value for the parameter. Since these values normally occur at the temperature extremes, additional noise immunity and guardbanding can be achieved by decreasing the allowable system operating ranges. Conditions for testing shown in the tables are chosen to guarantee operation under "worst case" conditions.

PLCC AC Electrical Characteristics

$V_{EE} = -4.2V$ to $-5.7V$, $V_{CC} = GND$, $V_{TTL} = +4.5V$ to $+5.5V$

Symbol	Parameter	$T_C = 0°C$		$T_C = +25°C$		$T_C = +85°C$		Units	Conditions
		Min	Max	Min	Max	Min	Max		
t_{PLH}	Propagation Delay	2.30	5.00	2.30	5.00	2.30	5.00	ns	Figures 1, 2
t_{PHL}	Clock to Output	3.00	5.60	3.00	5.60	3.40	6.40		
t_{PZL}	Output Enable Time	3.20	7.60	3.20	7.60	3.20	7.60	ns	Figures 1, 3
t_{PZH}	$\overline{OE} \downarrow$ to Q_N	2.40	5.60	2.40	5.60	2.40	5.60		
t_{PLZ}	Output Disable Time	3.20	7.60	3.20	7.60	3.20	7.60	ns	Figures 1, 3
t_{PHZ}	$\overline{OE} \uparrow$ to Q_N	2.40	5.60	2.40	5.60	2.40	5.60		
t_H	Data to CP \overline{EN}	1.5		1.5		1.5		ns	Figures 1, 2
	Hold Time	1.5		1.5		1.5			
t_S	Data to CP \overline{EN}	0.5		0.5		0.5		ns	Figures 1, 2
	Setup Time	0.5		0.5		0.5			
$t_{PW(H)}$	Clock Pulse Width	2.0		2.0		2.0		ns	Figures 1, 2

Test Circuit

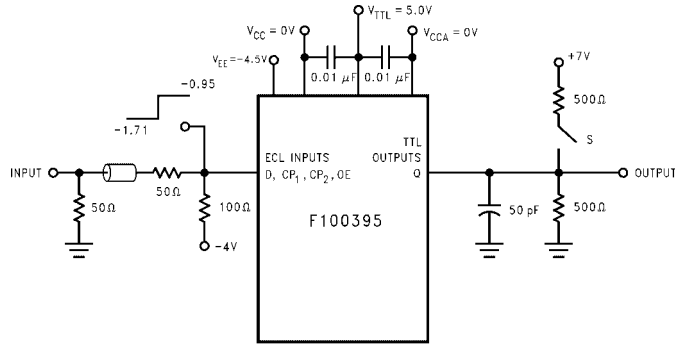

Notes:

$V_{CC} = 0V$, $V_{CCA} = 0V$, $V_{EE} = -4.5V$, $V_{TTL} = +5V$.

All unused outputs are loaded with 500Ω to GND. Decoupling capacitors are necessary in the test and end application environment. When V_{CC} and V_{CCA} are common to a single power plane, typically 0.0V, decouple V_{TTL} to that plane with one 0.01 μF capacitor.

FIGURE 1. AC Test Circuit

Switch Positions for Parameter Testing

Parameter	S-Position
t_{PLH} , t_{PHL}	Open
t_{PHZ} , t_{PZH}	Open
t_{PLZ} , t_{PZL}	Closed

Switching Waveforms

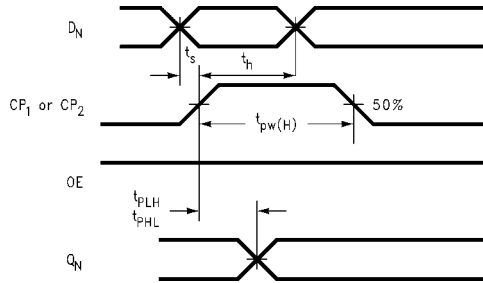

FIGURE 2. Propagation Delay and Transition Times

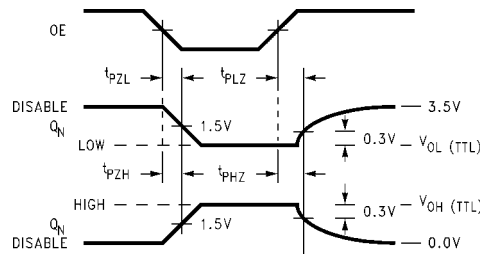
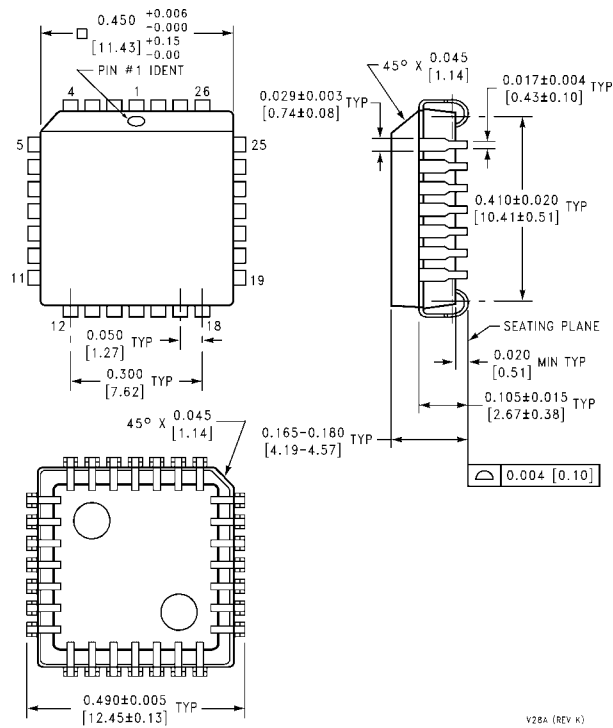

FIGURE 3. Enable and Disable Waveforms, OE to Q_N

Physical Dimensions inches (millimeters) unless otherwise noted



**28-Lead Plastic Lead Chip Carrier (PLCC), JEDEC MO-047, 0.450 Square
Package Number V28A**

V28A (REV K)

Fairchild does not assume any responsibility for use of any circuitry described, no circuit patent licenses are implied and Fairchild reserves the right at any time without notice to change said circuitry and specifications.

LIFE SUPPORT POLICY

FAIRCHILD'S PRODUCTS ARE NOT AUTHORIZED FOR USE AS CRITICAL COMPONENTS IN LIFE SUPPORT DEVICES OR SYSTEMS WITHOUT THE EXPRESS WRITTEN APPROVAL OF THE PRESIDENT OF FAIRCHILD SEMICONDUCTOR CORPORATION. As used herein:

1. Life support devices or systems are devices or systems which, (a) are intended for surgical implant into the body, or (b) support or sustain life, and (c) whose failure to perform when properly used in accordance with instructions for use provided in the labeling, can be reasonably expected to result in a significant injury to the user.
2. A critical component in any component of a life support device or system whose failure to perform can be reasonably expected to cause the failure of the life support device or system, or to affect its safety or effectiveness.

www.fairchildsemi.com

Looking for pricing, stock, or lifecycle information?

Click below to explore more details on WIN SOURCE:

- ⊖ [View 100395QC on WIN SOURCE](#)
- ⊖ [Fairchild/ON Semiconductor Information](#)

Optimize Your Supply Chain with WIN SOURCE Solutions

- ✓ Global Sourcing Solution
- ✓ Obsolete Management
- ✓ Cost Control Management
- ✓ Shortage Management
- ✓ Alternative Solution
- ✓ Excess Inventory Management