



**THE DATASHEET OF  
TLE9180D21QKXUMA1**



## Product Brief

# MOTIX™ BLDC Gate Driver ICs TLE9180D-21/31/32QK & TLE9183QK

The MOTIX™ TLE9180D-21/31/32QK and TLE9183QK are advanced gate driver ICs dedicated to control 6 external N-channel MOSFETs forming an inverter for high-current 3-phase motor drives application in the automotive sector.

A sophisticated high-voltage technology allows ICs to support applications for single and mixed battery systems with battery voltages of 12 V, 24 V and 48 V. Bridge, motor and supply related pins can withstand voltages of up to 90 V. Motor related pins can even withstand negative voltage transients down to - 15 V without damage.

All low- and high-side output stages are based on a floating concept and its driver strength allows to drive lowest R<sub>DS(on)</sub> MOSFETs common on the market. In 12 V applications the gate driver IC is capable of driving 6 MOSFETs, each with a maximum total gate charge of  $Q_{gTOT} = 300 \text{ nC}$ , at a frequency of up to 20 kHz. An integrated SPI interface is used to configure the IC for the application after power-up. After successful power-up parameters can be adjusted by SPI, monitoring data, configuration and error registers can be read. Cyclic redundancy check over data and address bits ensure safe communication and data integrity.

The MOTIX™ TLE9180D-21QK has two integrated current sense amplifier (CSA) for shunt signal conditioning, whereas the TLE9180D-31QK has three CSA, both devices are developed according to the ISO26262 workflow. The TLE9180D-32QK variant is specifically designed for 24/48 V applications with three integrated CSA and developed according to ISO26262 ASIL C workflow. TLE9183QK is designed on the other hand specifically for safety related 12V battery voltage applications and developed according to ISO 26262 ASIL D workflow. Gain and zero current voltage offset can be adjusted by SPI for all devices. The offset can be calibrated.

Diagnostic coverage and redundancy have increased steadily in recent years in automotive drive applications. Therefore, the MOTIX™ TLE9180D-31QK offers a wide range of diagnostic features, like monitoring of power supply voltages as well as system parameters. A testability of safety relevant supervision functions has been integrated. Failure behavior, threshold voltages and filter times of the supervisions of the device are adjustable via SPI.

### Key features

- › Supply range from 5.5 V - 60 V
- › Powerful driver stage with typ. 2 A output current per channel
- › 0 to 100% duty cycle range
- › Two integrated current sense amplifiers for shunt signal
- › Extended protection & supervision
- › LQFP-64 exposed pad package

### Key benefits

- › Suitable for 12 V, 24 V and 48 V battery voltages
- › Integrated load current measurement
- › Detailed diagnosis supports safety relevant use cases
- › Limp home mode
- › Product family approach with ISO26262 compliance

### Key applications

- › Cooling fans
- › Water pump
- › Oil pump
- › HVAC compressor
- › Electric power steering
- › Braking
- › 48 V motor drives
- › Commercial and agricultural vehicles

# MOTIX™ BLDC Gate Driver ICs

## TLE9180D-21/31/32QK & TLE9183QK

Typical application schematic

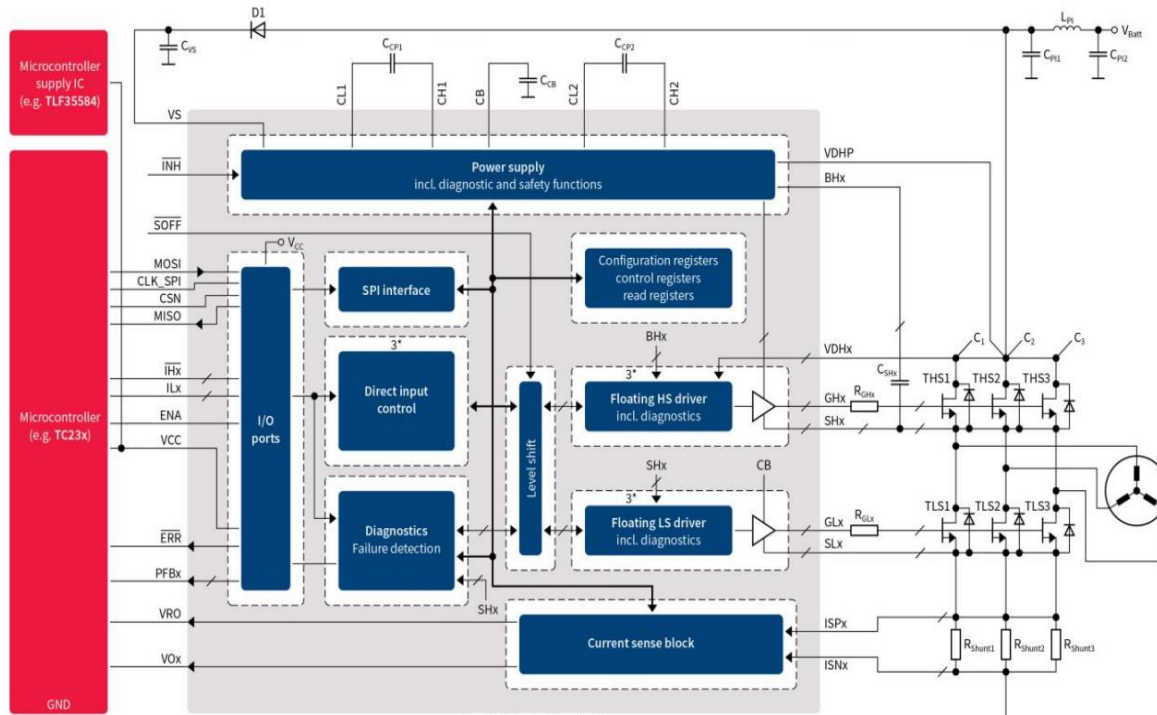

### Product summary

Product type	Current limit (min) [A]	OpAmps	Functional safety	Package	Orderable part number (OPN)
TLE9180D-21QK	3-phase gate driver IC with 2 current sense amplifier	2	ISO Ready	PG-LQFP-64	TLE9180D21QKXUMA1
TLE9180D-31QK	3-phase gate driver IC with 3 current sense amplifier	3	ISO Ready	PG-LQFP-64	TLE9180D31QKXUMA1
TLE9180D-32QK	3-phase gate driver IC with 3 current sense amplifier	3	ASIL C (48 V)	PG-LQFP-64	TLE9180D32QKXUMA1
TLE9183QK	3-phase gate driver IC with 3 current sense amplifier	3	ASIL D (12 V)	PG-LQFP-64	TLE9183QKXUMA1

Published by  
Infineon Technologies AG  
85579 Neubiberg, Germany

© 2023 Infineon Technologies AG.  
All Rights Reserved.

#### Please note!

THIS DOCUMENT IS FOR INFORMATION PURPOSES ONLY AND ANY INFORMATION GIVEN HEREIN SHALL IN NO EVENT BE REGARDED AS A WARRANTY, GUARANTEE OR DESCRIPTION OF ANY FUNCTIONALITY, CONDITIONS AND/OR QUALITY OF OUR PRODUCTS OR ANY SUITABILITY FOR A PARTICULAR PURPOSE. WITH REGARD TO THE TECHNICAL SPECIFICATIONS OF OUR PRODUCTS, WE KINDLY ASK YOU TO REFER TO THE RELEVANT PRODUCT DATA SHEETS PROVIDED BY US. OUR CUSTOMERS AND THEIR TECHNICAL DEPARTMENTS ARE REQUIRED TO EVALUATE THE SUITABILITY OF OUR PRODUCTS FOR THE INTENDED APPLICATION.

WE RESERVE THE RIGHT TO CHANGE THIS DOCUMENT AND/OR THE INFORMATION GIVEN HEREIN AT ANY TIME.

#### Additional information

For further information on technologies, our products, the application of our products, delivery terms and conditions and/or prices please contact your nearest Infineon Technologies office ([www.infineon.com](http://www.infineon.com)).

#### Warnings

Due to technical requirements, our products may contain dangerous substances. For information on the types in question please contact your nearest Infineon Technologies office.

Except as otherwise explicitly approved by us in a written document signed by authorized representatives of Infineon Technologies, our products may not be used in any life endangering applications, including but not limited to medical, nuclear, military, life critical or any other applications where a failure of the product or any consequences of the use thereof can result in personal injury.

## Looking for pricing, stock, or lifecycle information?

Click below to explore more details on WIN SOURCE:

- ⊖ [View TLE9180D21QKXUMA1 on WIN SOURCE](#)
- ⊖ [Infineon Technologies Information](#)

## Optimize Your Supply Chain with WIN SOURCE Solutions

- ✓ Global Sourcing Solution
- ✓ Obsolete Management
- ✓ Cost Control Management
- ✓ Shortage Management
- ✓ Alternative Solution
- ✓ Excess Inventory Management