



**THE DATASHEET OF  
TDA21570AUMA1**



## 1 Description

- High frequency, low profile DC-DC converters;
- Voltage Regulators for CPUs, GPUs and DDR memory arrays;
- Telecom controlled and uncontrolled

The TDA21570 integrated power-stage contains a low quiescent current synchronous buck gate-driver IC which is co-packed with control and synchronous MOSFETs along with an active diode structure that achieves low  $V_{sd}$  similar to a schottky with very little reverse recovery charge. The package is optimized for PCB layout, heat transfer, driver/MOSFET control timing, and minimal switch node ringing when layout guidelines are followed. The paired gate driver and MOSFET combination enables higher efficiency at lower output voltages required by cutting edge CPU, GPU and DDR memory designs.

The internal MOSFET sensing achieves superior current sense accuracy vs. best-in-class controller-based Inductor DCR sense methods.

Protection includes IC temperature reporting and over temperature protection feature (OTP with thermal shutdown), cycle-by-cycle over current protection (OCP), control MOSFET short detection (HSS - High side short detection), VDRV and bootstrap under-voltage protection. The TDA21570 also features "refreshing" of bootstrap capacitor to prevent the bootstrap capacitor from over-discharging.

Operation of up to 1.5 MHz switching frequency enables high performance transient response, allowing miniaturization of output inductors, as well as input and output capacitors while maintaining industry leading efficiency.

### Features

- Integrated driver, active diode, control MOSFET Q1 and synchronous MOSFET Q2
- On-chip MOSFET Current sensing and reporting at 5  $\mu\text{A}/\text{A}$ .
- Input voltage ( $V_{IN}$ ) range of 4.25 V to 16 V
- VCC and VDRV supply of 4.25 V to 5.5 V
- Output voltage range from 0.225 V up to 5.5 V at  $V_{IN} = 12\text{ V}$
- Output current capability of 70 A
- Operation up to 1.5 MHz
- Enhanced Fault reporting and identification
- VDRV under voltage lockout (UVLO)
- Bootstrap under-voltage protection
- 8mV /  $^{\circ}\text{C}$  temperature analog output
- Over temperature protection and thermal shutdown
- Cycle-by-cycle over current Protection (OCP) and flag
- Control MOSFET short (HSS) detection and flag
- Auto-replenishment on bootstrap capacitor
- Compatible with 3.3 V tri-state PWM Input
- Body-Braking™ load transient support
- DEEP SLEEP mode for power saving via EN= low (32  $\mu\text{A}$  typ)
- Small 5 mm x 6 mm x 0.9 mm PQFN package
- Lead free RoHS compliant package

Description

**Table 1** Product Identification

Part Number	Temp Range	Package	Marking
TDA21570	-40 to 125°C	PQFN 5 mm x 6 mm	TDA21570

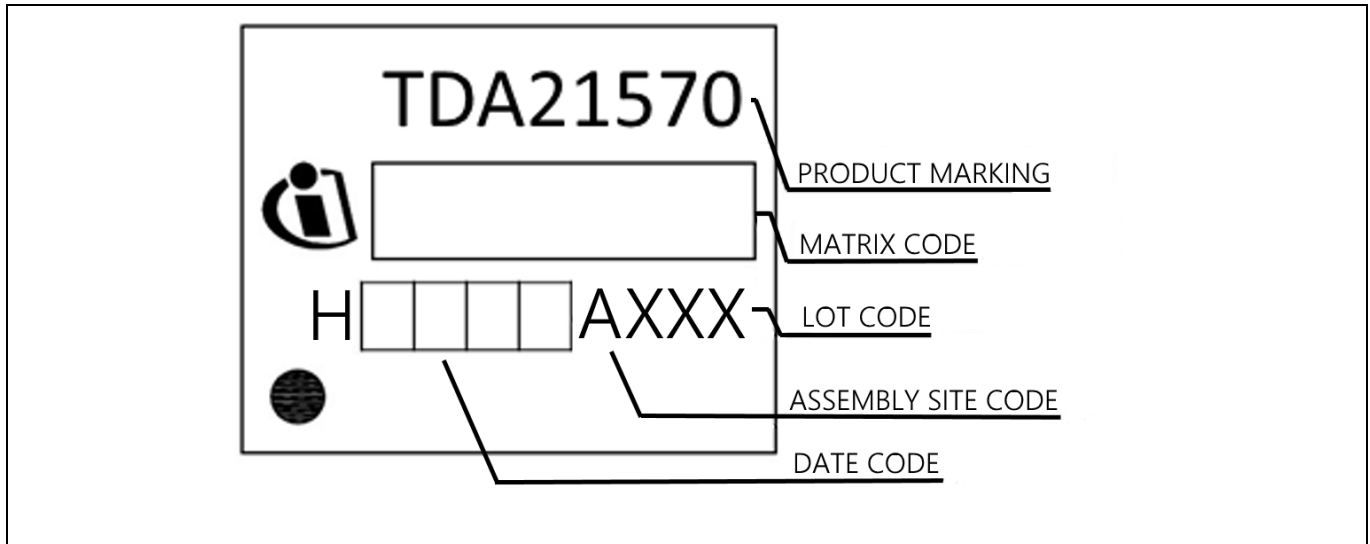

Figure 1 Picture of the Product

## 2 Description

### 2.1 Pinout

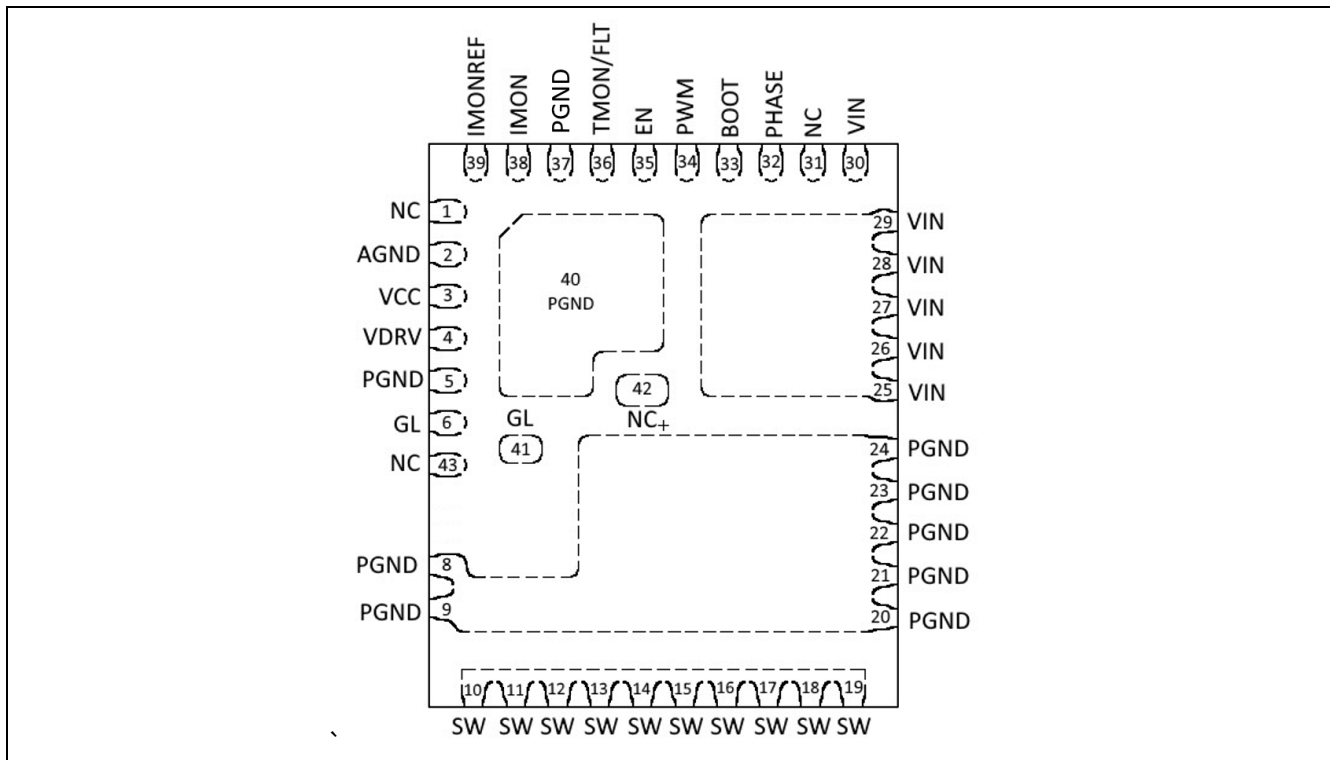

Figure 2 Pinout, Numbering and Name of Pins (transparent top view)

Note: Pin 7 omitted for compatibility with TDA2147x

## Description

Table 2 I/O Signals

Pin No.	Name	Pin Type	Buffer Type	Function
6, 41	GL	I/O	Analog	Low-side MOSFET driver pin that can be connected to a test point in order to observe the waveform.
10-19	SW	O	Analog	Switching node of synchronous buck converter.
32	PHASE	I	Analog	Switching node. For Bootstrap capacitor connection only.
33	BOOT	I	Analog	Bootstrap capacitor connection. Connect an X7R ceramic capacitor with value between 0.22 $\mu$ F to 0.56 $\mu$ F from BOOT to PHASE pin. Recommended value is 0.47 $\mu$ F. The bootstrap capacitor provides the charge to turn on the control MOSFET. For $V_{IN} > 13.2$ V, a 2- $\Omega$ bootstrap resistor in series with the capacitor is required to help reduce SW ringing and EMI.
34	PWM	I/O	+3.3 V logic	3.3 V logic level PWM input. PWM input: “High” turns control MOSFET on; “Tri-state” turns both MOSFETs off; “Low” turns the synchronous MOSFET on.
35	EN	I	+3.3 V logic	Pulling EN high enables the driver; pulling EN low disables the driver and enters ultra-low quiescent current mode. Floating this pin is not recommended, however a pull-down is embedded to keep the driver off if the pin is floating. Pin is VCC tolerant.
36	TMON / FAULT	O	Analog	The voltage at this pin is defined by the equation $8\text{mV} * (\text{Celsius Temperature}) + 0.6$ V. This pin will be pulled up to 3.3 V under severe over-temperature, over-current, HSS or bootstrap under-voltage condition.
38	IMON	O	Analog	Sensed current output signal referenced to the IMONREF pin through external resistor. V (IMON – IMONREF) voltage across that resistor represents current information.
39	IMONREF	I/O	Analog	This pin provides a system reference for the IMON information. This pin can be tied to a fixed voltage between 1.1 V and 1.9 V such as bias rails of a PWM controller.

## Description

**Table 3 Power Supply**

Pin No.	Name	Pin Type	Buffer Type	Function
4	VDRV	POWER	–	The supply of gate driver. Connect a 1 $\mu$ Fcap between VDRV and PGND. VDRV should be connected to +5 V power supply.
3	VCC	POWER	–	Bias voltage for control logic. Connect a 1 $\mu$ Fcap between VCC and AGND. VCC should be connected to +5 V power supply.
25-30	VIN	POWER	–	4.25 V to 16 V high current input voltage connection.

**Table 4 Not Connected**

Pin No.	Name	Pin Type	Buffer Type	Function
1, 31, 43, 42	NC	–	–	Leave the pin unconnected.

**Table 5 Ground Pins**

Pin No.	Name	Pin Type	Buffer Type	Function
2	AGND	GND	–	Signal ground. All interface signals are referenced to this pin.
5, 8, 9, 20-24, 37	PGND	GND	–	Power ground. It is also the power ground of the synchronous MOSFET.

### 3 Simplified Block Diagram

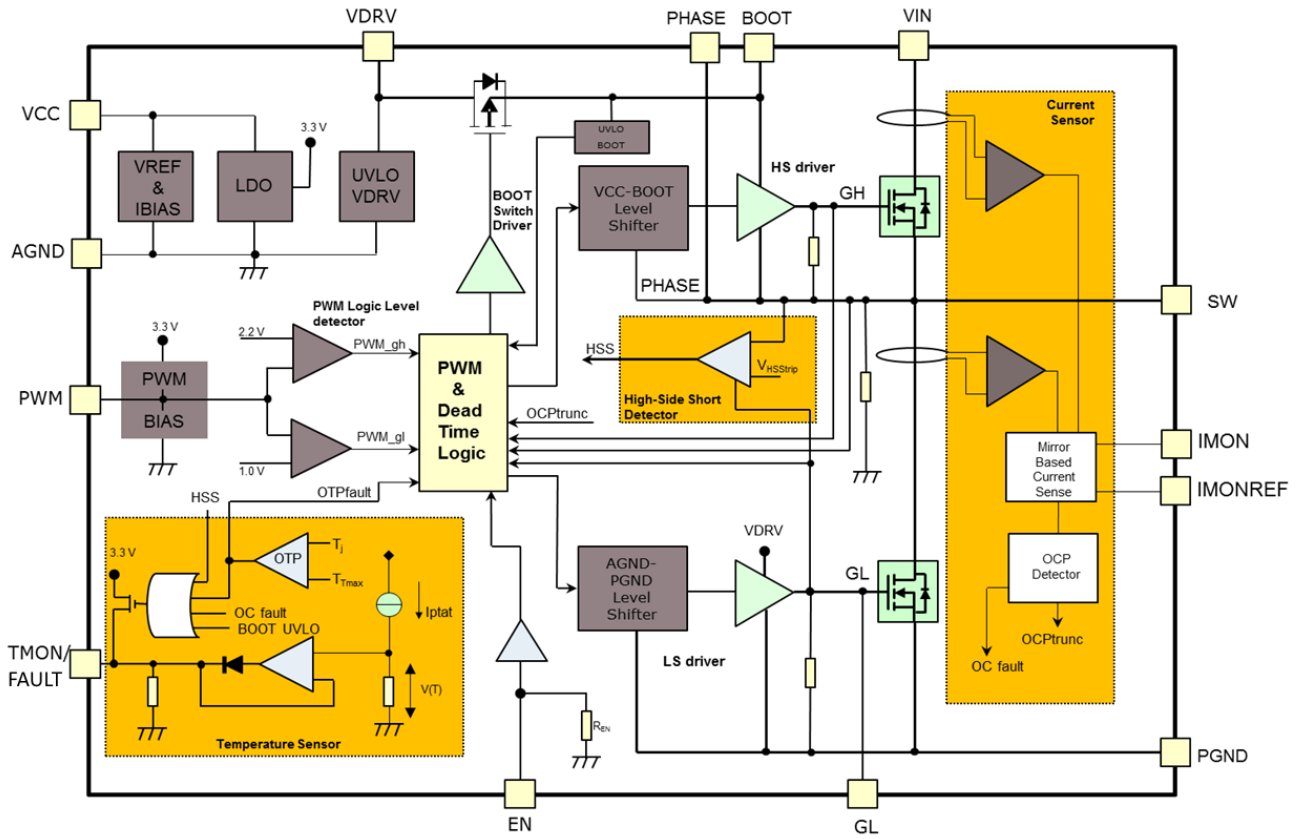

Figure 3 Simplified Block Diagram

## Electrical Specification

## 4 Electrical Specification

### 4.1 Absolute Maximum Ratings

Note:  $T_A = 25\text{ °C}$

Stresses above those listed in Table 6 “Absolute Maximum Ratings” may cause permanent damage to the device. These are absolute stress ratings only and operation of the device is not implied or recommended at these or any other conditions in excess of those given in the operational sections of this specification. Exposure over values of the recommended ratings for extended periods may adversely affect the operation and reliability of the device.

**Table 6 Absolute Maximum Ratings**

Parameter	Symbol	Values			Unit	Note
		Min.	Typ.	Max.		
Frequency of the PWM input	$f_{SW}$	0.1	–	1.5	MHz	
Maximum average load current	$I_{OUT}$	–	–	70	A	
Input Voltage	$V_{IN}$	-0.30	–	25	V	Pin VIN
Logic supply voltage	$V_{CC}$	-0.3	–	6.5	V	Pin VCC
High and low-side driver voltage	$V_{DRV}$	-0.3	–	6.5	V	Pin VDRV
Switch node voltage	$V_{SW}$ (DC)	-1	–	25	V	Pin SW
	$V_{SW}$ (AC)	Below -5V for 5ns	–	34 for 1ns		
PHASE voltage	$V_{PHASE}$ (DC)	-1	–	25	V	Pin PHASE
	$V_{PHASE}$ (AC)	Below -5V for 5ns	–	34 for 1ns		
VIN-PHASE Voltage	$V_{VIN-PHASE}$ (DC)	-1	–	25	V	
	$V_{VIN-PHASE}$ (AC)	Below -5V for 5ns	–	34 for 1ns		
BOOT voltage	$V_{BOOT}$ (DC)	-0.3	–	29	V	Pin BOOT
	$V_{BOOT}$ (AC)	Below -0.3V for 5ns	–	–		
	$V_{BOOT-PHASE}$	-0.3	–	6.5V (DC), 7.5V for 3ns		–
GL voltage	$V_{GL}$	-0.3	–	6.5	V	Pin GL
EN voltage	$V_{EN}$	-0.3	–	6.5	V	Pin EN
PWM voltage	$V_{PWM}$	-0.3	–	3.6	V	Pin PWM
TMON voltage	$V_{TMON}$	-0.3	–	3.6	V	Pin TMON / FAULT
IMON voltage	$V_{IMON}$	-0.3	–	3.6	V	Pin IMON
IMONREF voltage	$V_{IMONREF}$	-0.3	–	3.6	V	Pin IMONREF
NC Pin (Pin 43) voltage	$V_{43}$	-0.3	–	0.3	V	Pin NC
Junction temperature	$T_{Jmax}$	-40	–	150	°C	–
Storage temperature	$T_{STG}$	-55	–	150	°C	–

Note: All rated voltages are relative to voltages on the AGND and PGND pins unless otherwise specified.

## Electrical Specification

## 4.2 Thermal Characteristics

Table 7 Thermal Characteristics

Parameter	Symbol	Values			Unit	Note / Test Condition
		Min.	Typ.	Max.		
Thermal resistance-Junction to PCB (pin 24)	$\theta_{JC\_PCB}$	-	1.5	-	K/W	-
Thermal resistance-Junction to top of package	$\theta_{JC\_Top}$	-	16.7	-		-
Thermal resistance to ambient	$\theta_{JA}$ <sup>Note</sup>	-	20.5	-		-

Note: Thermal Resistance ( $\theta_{JA}$ ) is measured with the component mounted on a high effective thermal conductivity test board in free air.

## 4.3 Recommended Operating Conditions

Table 8 Recommended Operating Conditions

Parameter	Symbol	Values			Unit	Note / Test Condition
		Min.	Typ.	Max.		
Input voltage	$V_{IN}$	4.25	-	16	V	-
MOSFET driver voltage	$V_{DRV}$	4.25	-	5.5		-
Logic supply voltage	$V_{CC}$	4.25	-	5.5		-
Frequency of the PWM	$f_{SW}$	100	-	1500	kHz	-
EN voltage	$V_{EN}$	-	-	5.5	V	Pin EN
PWM voltage	$V_{PWM}$	-	-	3.6	V	Pin PWM
Current Sense reference voltage	$V_{IMON\_CM}$	1.1	-	1.9	V	Pins IMON, IMONREF
Junction temperature	$T_{JOP}$	-40	-	+125	°C	-

## 4.4 Electrical Characteristics

Note:  $V_{DRV} = V_{CC} = 5\text{ V}$ ,  $T_J = 25\text{ °C}$ ,  $V_{IMONREF} = 1.2\text{ V}$

Table 9 Voltage Supply, Biasing Current

Parameter	Symbol	Values			Unit	Note / Test Condition
		Min.	Typ.	Max.		
UVLO VDRV rising	$V_{UVLO\_R}$	-	4.05	-	V	
UVLO VDRV falling	$V_{UVLO\_F}$	-	3.85	-		
Bootstrap Under voltage rising threshold	$V_{UVBOOT\_R}$	-	3.82	-		
Bootstrap Under voltage falling threshold	$V_{UVBOOT\_F}$	-	3.61	-		
Driver current	$I_{VDRV}$	-	29	-	mA	EN = H, $f_{sw} = 600\text{ kHz}$ , D=15%
		-	2.5	-	μA	EN = L
Supply Current	$I_{VCC}$	-	8	-	mA	EN = H, $f_{sw} = 600\text{ kHz}$ , D=15%
		-	30	-	μA	EN = L
VIN Current	$I_{VIN}$	-	-	5	μA	No switching, EN=L

Electrical Specification

Table 10 Current Sense

Parameter		Symbol	Values			Unit	Note / Test Condition
			Min.	Typ.	Max.		
IMON	IMON Voltage range	$V_{IMON}$	0.8	-	2.35	V	DC + AC components <sup>Note 1</sup>
	IMON/IMONREF reference voltage range	$V_{IMON\_CM}$	1.1	-	1.9	V	Reference Voltage connected externally for the current sense signal
	Current sense gain	$A_{CS}$	-	5	-	$\mu A/A$	
	IMON Gain resistor range	$R_{IMON}$	-	1	-	k $\Omega$	Resistor to be connected between IMON and IMONREF. For 5mV/A, recommended 1k $\Omega$ $R_{IMON}$

Table 11 Temperature Sense and Fault Communication

Parameter		Symbol	Values			Unit	Note / Test Condition
			Min.	Typ.	Max.		
TMON / FAULT	Temperature Sense Slope	$A_{TMPGAIN}$	-	8.0	-	mV/°C	$25^{\circ}C \leq T_J \leq 125^{\circ}C$ , <sup>Note 1</sup>
	Temperature Sense Offset Voltage	$V_{TMPOFFSE}$ T	-	800	-	mV	$T_J = 25^{\circ}C, 0.6 V + 8 mV/^{\circ}C * T_J$

Table 12 Other Logic Functions, Inputs/Outputs And Thresholds

Parameter		Symbol	Values			Unit	Note / Test Condition
			Min.	Typ.	Max.		
EN	Enable Power-on Delay	$t_{EN\_ondelay}$	-	17	-	$\mu s$	PWM=0. Measured from EN rising edge to $V_{GL} > 1 V$ . <sup>Note 1</sup>
	Enable Power-off Delay	$t_{EN\_offdelay}$	0.1	-	1	$\mu s$	PWM=0. Measured from EN falling edge to $V_{GL} < 4 V$ . <sup>Note 1</sup>
	Internal Pull down Resistance	$R_{PULLDN\_EN}$	-	280	-	k $\Omega$	When EN is floating
	Input High Voltage	$V_{EN\_H}$	2.0	-	-	V	
	Input Low Voltage	$V_{EN\_L}$	-	-	0.95	V	
PWM	PWM Input High Threshold	$V_{IH}$	2.4	-	-	V	PWM Low or Tri-state to High
	PWM Input Low Threshold	$V_{IL}$	-	-	0.8	V	PWM High or Tri-state to Low
	PWM Hysteresis	$I_{PWM\_HYS}$	-	40	-	mV	Active to Tri-state or Tri-state to Active

## Electrical Specification

Table 13 Protection

Parameter		Symbol	Values			Unit	Note / Test Condition
			Min.	Typ.	Max.		
OTP	Over Temp Rising Threshold	$T_{RISE}$	-	140	-	°C	TMON/FAULT pulled up high <sup>Note 1</sup>
	Over Temp Falling Threshold	$T_{FALL}$	-	128	-	°C	TMON/FAULT released <sup>Note 1</sup>
HSS FAULT	High-side MOSFET Short Threshold	$V_{HSS\_TH}$	-	560	-	mV	$V_{SW} - V_{PGND}$
	TMON/FAULT Delay	$T_{HSS\_DEL}$	-	150	-	ns	After $V_{HSS\_TH}$ is detected and TMON/FAULT is pulled high
OCP	Over-Current Threshold	$I_{OCP\_TH}$	-	100	-	A	
	Over-Current Delay	$T_{OCP\_DEL}$	10	-	-	Cycle	PWM High-Low Cycles to TMON/FAULT is pulled high

## Notes

1. Guaranteed by design but not tested in production

## 5 Typical operating conditions

Single Phase Circuit of Figure 18,  $V_{IN} = 12\text{ V}$ ,  $V_{OUT} = 1.8\text{ V}$ ,  $f_{SW} = 1\text{ MHz}$ ,  $L = 100\text{ nH}$ ,  $V_{CC} = V_{DRV} = 5\text{ V}$ ,  $T_{AMBIENT} = 25\text{ °C}$ , no heat sink, no air flow, 8-layer PCB board of 3.7”(L) x 2.6”(W), no PWM controller loss, no inductor loss, unless specified otherwise.

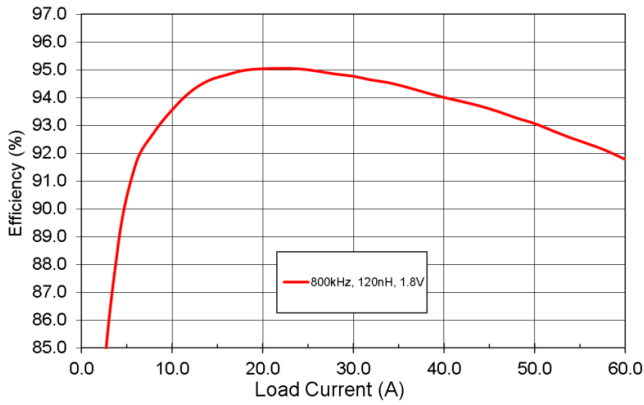

Figure 3 Powerstage Efficiency

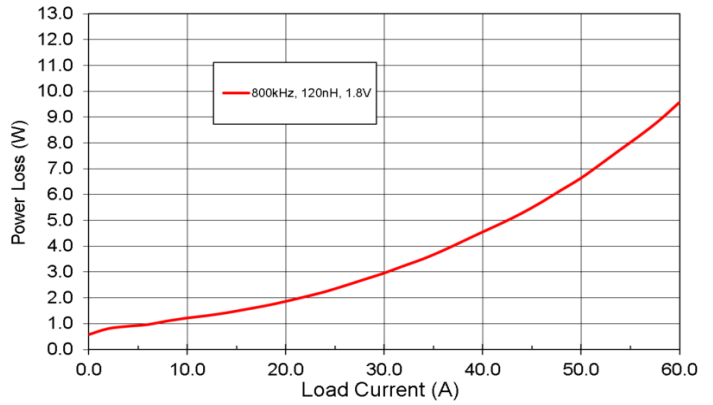

Figure 4 Power stage Loss

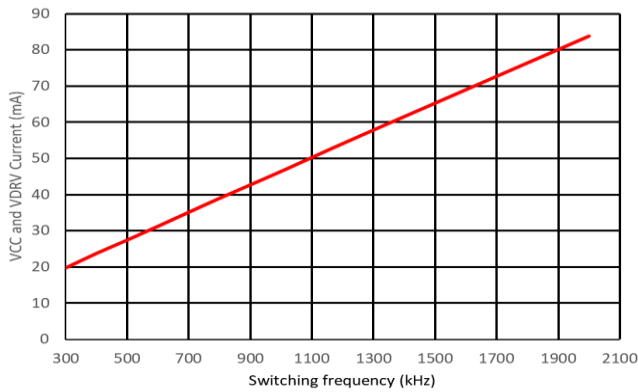

Figure 5 VCC / VDRV current v/s Frequency

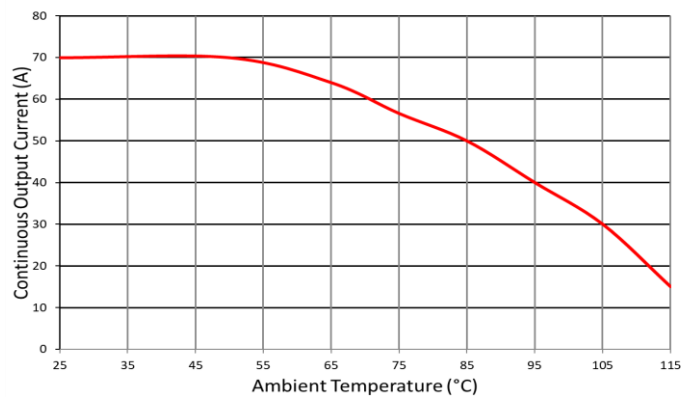

Figure 6 Thermal derating,  $T_{case} \leq 125\text{ °C}$

## **6 Theory of Operation**

### **6.1 Description**

The TDA21570 contains an improved high speed MOSFET driver optimized to drive a pair of co-packaged high-side and low-side OptiMOS MOSFETs at frequency up to 1.5 MHz. Dc-dc controllers using traditional current sense methods like DCR sensing and R<sub>ds(on)</sub> sensing typically have limitations. DCR current sensing is sensitive to temperature changes of the inductor and needs temperature compensation either implemented externally using a thermo-couple or inside the power stage. R<sub>ds(on)</sub> current sensing, on the other hand, is not dependent on the inductor but there is a temperature co-efficient associated with the MOSFET r<sub>ds(on)</sub>. Besides, it is difficult to implement r<sub>ds(on)</sub> current sensing for high-side MOSFET which is therefore replaced by emulated current while the low-side current is sensed across the MOSFET. With the advanced current-mirror sensing in TDA21570, all these limitations are eliminated while achieving superior accuracy. Current on both high-side as well as low-side MOSFET is mirrored on a sense MOSFET which is a part of the main MOSFET device, and hence comes with an inherent temperature compensation without the need for an additional circuitry. Real current-sensing on both MOSFET ensures that the system is always monitoring the real output current and can immediately react to any critical events like load step or over-current fault.

The TDA21570 reports accurate temperature with the gain of 8 mV / °C, which helps the system to actively monitor the temperature in real time. Temperature outputs from multiple power stages can be connected together to report the highest temperature to Infineon's digital PWM controller.

The TDA21570 PWM input is compatible with industry standard 3.3V PWM input with tri-state.

The TDA21570 can enable Body-Braking mode by responding to PWM tri-state signals sent from the controller, quickly disabling both MOSFETs in the power stage in order to enhance transient performance or provide a high impedance output.

The TDA21570 supports diode emulation mode through the PWM tri-state signal. Controlled by Infineon's digital PWM controller, the PWM tri-state signal will force the low-side FET to be off when the inductor current is about to go negative. The light-load efficiency then can be increased by preventing conduction loss caused by negative inductor current.

The TDA21570 also supports deep-sleep power saving mode. When in deep-sleep mode, the driver will disable most of the function circuitry to greatly reduce power consumption.

The TDA21570 features a full-range of protection, including VCC/VDRV Under-Voltage-Lockout (UVLO), thermal shutdown against an internal over-temperature condition, phase fault detection of a shorted high-side MOSFET,

**Theory of Operation**

and programmable cycle-by-cycle over-current protection due to an overload condition or saturated output inductor.

The TDA21570 also features internal protection circuitry to automatically replenish the voltage across the bootstrap capacitor. It avoids the gradual depletion of capacitor energy when the power stage sits in tri-state for a long period of time.

**6.2 Sleep Modes**

When EN is pulled low, the power stage enters deep-sleep mode. The gate driver circuitry will be turned off immediately and most of the logic circuitry will be shut down to reduce the bias current to less than 32  $\mu\text{A}$ . The IMON output will be shorted to IMONREF in deep sleep mode.

When EN toggles from low to high, the power stage will be active and able to accept PWM signals after a delay of 17  $\mu\text{s}$ .

**6.3 Current Sensing and Reporting**

The TDA21570 features a very accurate current mirror architecture on both high-side as well as low-side MOSFET, thus reporting the real time current information. The current information is reported using the IMON and IMONREF pins. A differential connection between IMON and IMONREF pins is connected to the PWM controller to report the powerstage current information to the controller. The reported current is in the form of current output with the gain of  $5\mu\text{A}/\text{A}$ . In order to convert this into voltage, a 1K $\Omega$ , 0.1% resistor is recommended between the IMON and IMONREF pins, close to the controller. The converted voltage signal at the controller side has an effective gain of 5mV/A i.e. for every 1 A load, the controller will read 5mV from the power stage. The current-output differential signal from the power stage provides excellent noise immunity to the reported current information.

**6.4 Advanced Fault Reporting**

TDA21570 uses TMON / FAULT pin for reporting all types of faults detected. Since typical multiphase applications connect the TMON / FAULT signal from all the phases in a particular loop into a wired OR connection, the system cannot distinguish the faulty phase and the type of fault occurred. This is resolved by using advanced fault reporting in TDA21570 which uses a combination of TMON / FAULT and IMON signals to identify the fault. Since the IMON is separately connected from each phase to the controller, it provides phase-specific information in the event of a fault. Appropriate IMON response to each fault is explained in the corresponding fault sub-sections further. A summary of fault reporting is given in the Table 15 at the end of Section 4.

## 6.5 VDRV Undervoltage Lock-out (UVLO)

TDA21570 features a VDRV under voltage lock-out fault circuitry that monitors the VDRV voltage actively. As shown in Table 15, this is a non-catastrophic fault and the TMON/FAULT pin is pulled low with a weak pull down as long as the VDRV voltage is below the UVLO threshold. If the power stage has not started up, the power stage PWM pin is also pulled down to 0V with a weak pull down. This can be monitored by the PWM controller as a signal from the power stage indicating that it is not ready yet for power up. As soon as VDRV voltage is above the UVLO threshold, the PWM pin is at tri state instead of 0V, this indicating the controller that it is OK to send the PWM signals. At the same time, TDA21570 shorts IMON and IMONREF thus identifying itself to the controller that it is in UVLO condition.

Once the powerstage is in normal operation, if then it encounters a VDRV UVLO condition, the power stage stops switching, and both TMON and IMON pins are pulled down to 0V. If there are multiple phases connected in the same loop, the TMON pin voltage, being connected to other power stage TMON pins, will continue reporting the highest power stage temperature. But the controller can still detect IMON pin voltage to be 0V (IMON –IMONREF = -IMONREF, as seen by the controller), and thus identify this faulty phase. Since TMON pin is not pulled high, but continues reporting the temperature, this can be distinguished from a BOOT UVLO condition as shown in Table 15.

## 6.6 Temperature Reporting and Over-temperature protection

An internal temperature-sense circuit monitors the temperature of the TDA21570. The sensed temperature is reported at the TMON/FAULT pin with a linear voltage slope of 8mV/°C and a 0.6V offset at 0°C, as shown in equation (1).

$$V_{TMON/FAULT} (V) = 0.6V + 0.008V / ^\circ C \times T_j(^{\circ}C) \dots\dots\dots (1)$$

The TMON/FAULT pin also serves as a FAULT pin that is pulled to 3.3V in case of any catastrophic faults and is pulled down to 0V in case of any non-catastrophic faults. When there is no fault, it continues reporting temperature as long as the VCC supply is connected to a voltage in the recommended operating range.

Once the temperature rises above the OTP rising threshold (140 °C), the TMON/FAULT output will be pulled high immediately but the driver will continue responding to the PWM signal input from the controller. The controller decides whether to stop the regulation of the VR or continue switching. The TMON/FAULT will remain high until temperature falls below the falling threshold (128 °C). As soon as TMON is pulled high during OTP, the IMON is internally shorted to IMONREF, thus identifying the faulty phase and occurrence of OTP to the system. The system can then respond accordingly.

## **6.7 Over Current Protection and Flag**

This feature protects the power stage from self-destruction from repetitive high current events such as saturated inductors due to poor component selection or by incorrectly optimized control loops. These high current events could eventually lead to a shorted high-side MOSFET failure.

With cycle-by-cycle self-preservation, the current is monitored every cycle. If the over-current threshold (default 100 A) has been exceeded, the PWM high pulse will be truncated so that the inductor current is allowed to relax. When TDA21570 detects 10 consecutive PWM cycle over-current events, the TMON/FAULT pin is flagged high to indicate the controller of the fault. The TMON/FAULT flagged “high” along with IMON information crossing the over-current threshold helps the controller identify the faulty phase that caused OC.

## **6.8 Bootstrap Capacitor Under-Voltage**

TDA21570 features a bootstrap capacitor under voltage circuitry that detects a missing bootstrap capacitor before powering up or a damaged bootstrap capacitor during normal operation. Once bootstrap capacitor under voltage is determined, the TMON/FAULT pin will pulled high to report a catastrophic fault to the PWM controller. At the same time, IMON pin is pulled to 0V or GND voltage, thus effectively indicating a negative IMONREF voltage differential between IMON and IMONREF pins at the controller.

Theory of Operation

Table 15 Advanced Fault Reporting and Identification

Fault Severity Level	Type of Fault	Power stage PWM Response	Power stage IMON Response	Powerstage TMON Response	Recommended Controller Identification Criteria
Non-Catastrophic	VDRV UVLO (power-up)	Weak pull down to 0V (PWM pin voltage can be driven by controller, no switching on powerstage)	= IMONREF	Weak pull down to 0V (or $V_{TMON}$ from other power stages in same loop)	TMON < 2V, PWM < 0.8V
	VDRV UVLO (normal operation)	Weak pull down to 0V (PWM pin voltage can be driven by controller, no switching on powerstage)	= 0V	Weak pull down to 0V (or $V_{TMON}$ from other power stages in same loop)	TMON < 2V, IMON < 0.4V
Catastrophic	OTP	Power stage stops switching until OTP clears	= 0V	= 3.3V	TMON > 2.6V, IMON=IMONREF, 1V < IMON < 2V
	OCP (10 events without 3 consecutive good cycles)	Power stage continues responding to PWM signal from controller. Truncates high side pulse until powerstage is in OCP.	Continues reporting current	= 3.3V	TMON > 2.6V, IMON-IMONREF > CTRL_OCP, IMON < 2.6V
	HSS (1 <sup>st</sup> event)	Power stage continues responding to PWM signal from controller.	= 3.3V (latched)	= 3.3V	TMON > 2.6V, IMON > 2.6V
	BOOT UVLO (10 events without 3 consecutive good cycles)	Power stage continues responding to PWM signal from controller.	= 0V (latched)	= 3.3V	TMON > 2.6V, IMON < 0.4V

# 7 Application

## 7.1 Typical Application

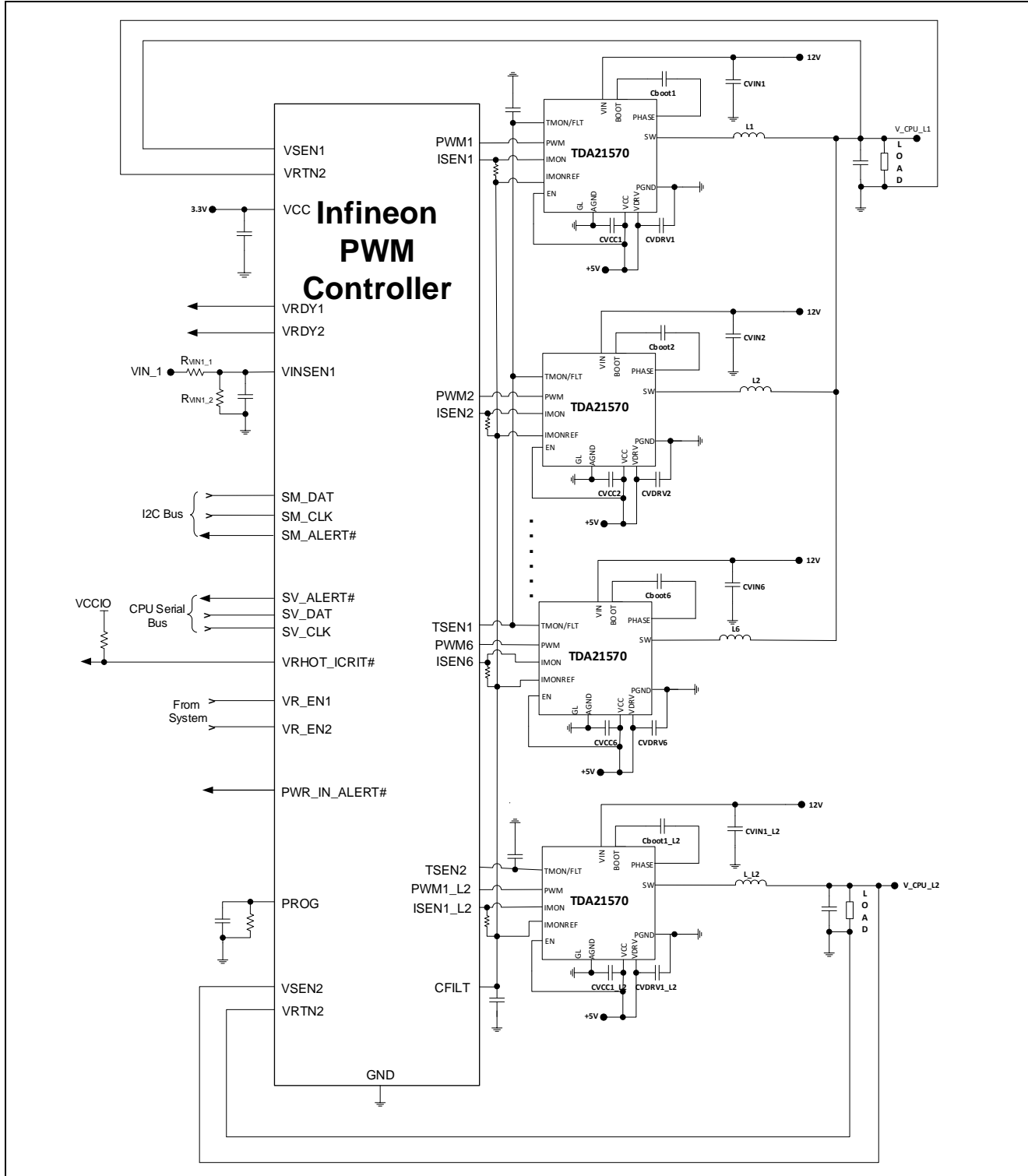

Figure 6 6+1 - Phase Voltage Regulator - Typical Application (simplified schematic)

### 8 Mechanical Drawing PQFN

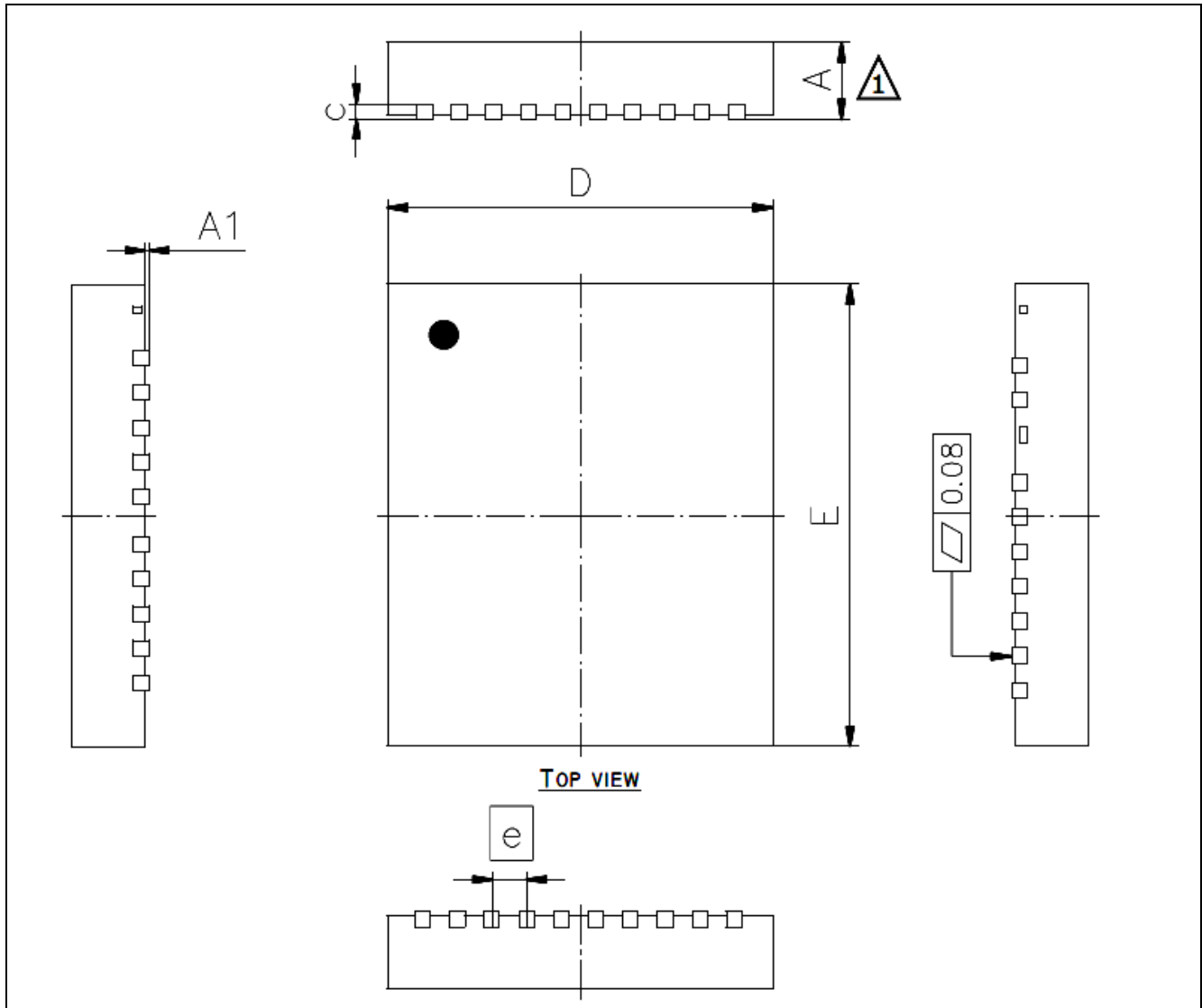

Figure 7 Mechanical Dimensions of Package (Top View and Side View) in mm

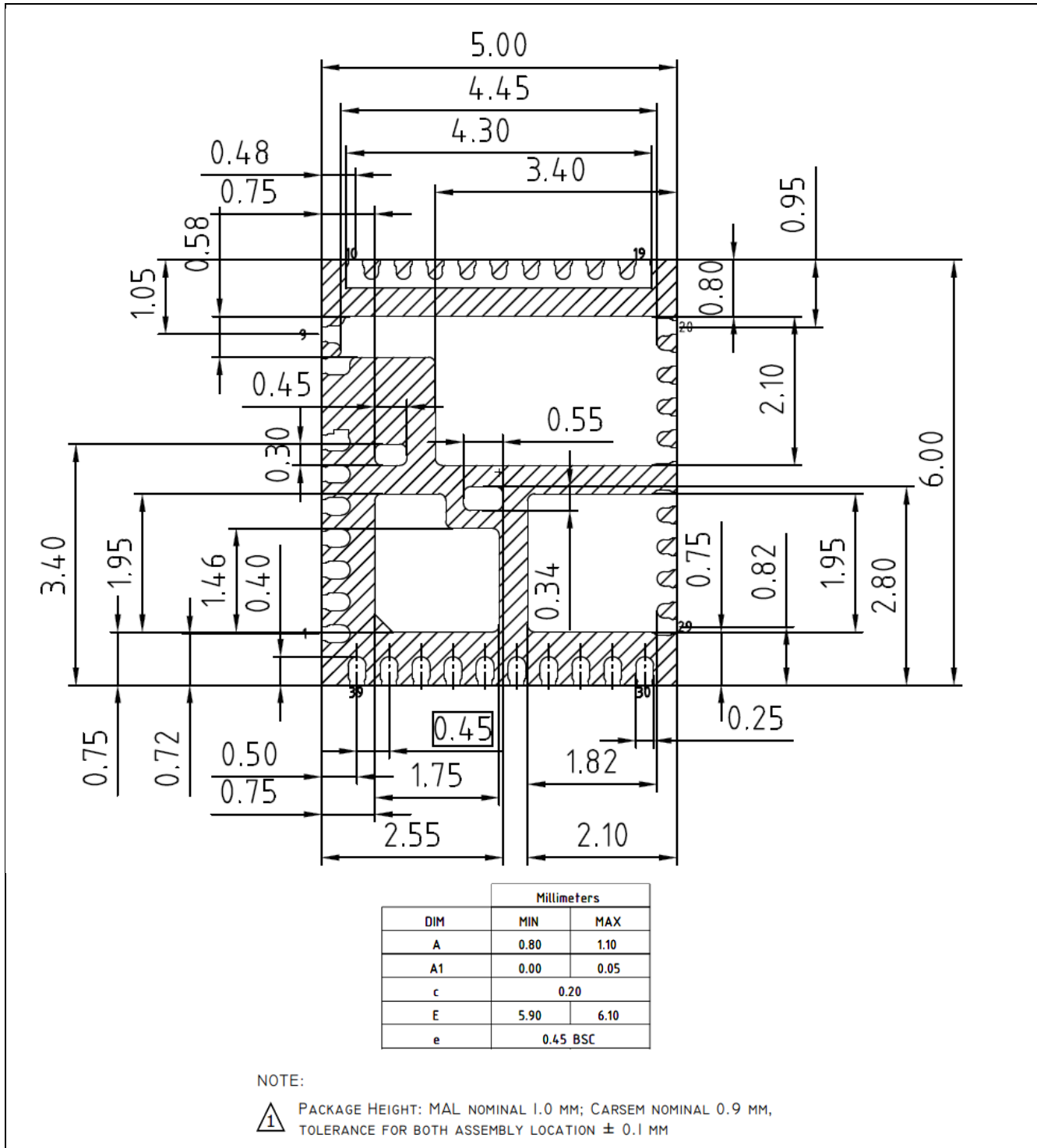

Figure 8 Mechanical Dimensions of Package (Bottom View) in mm

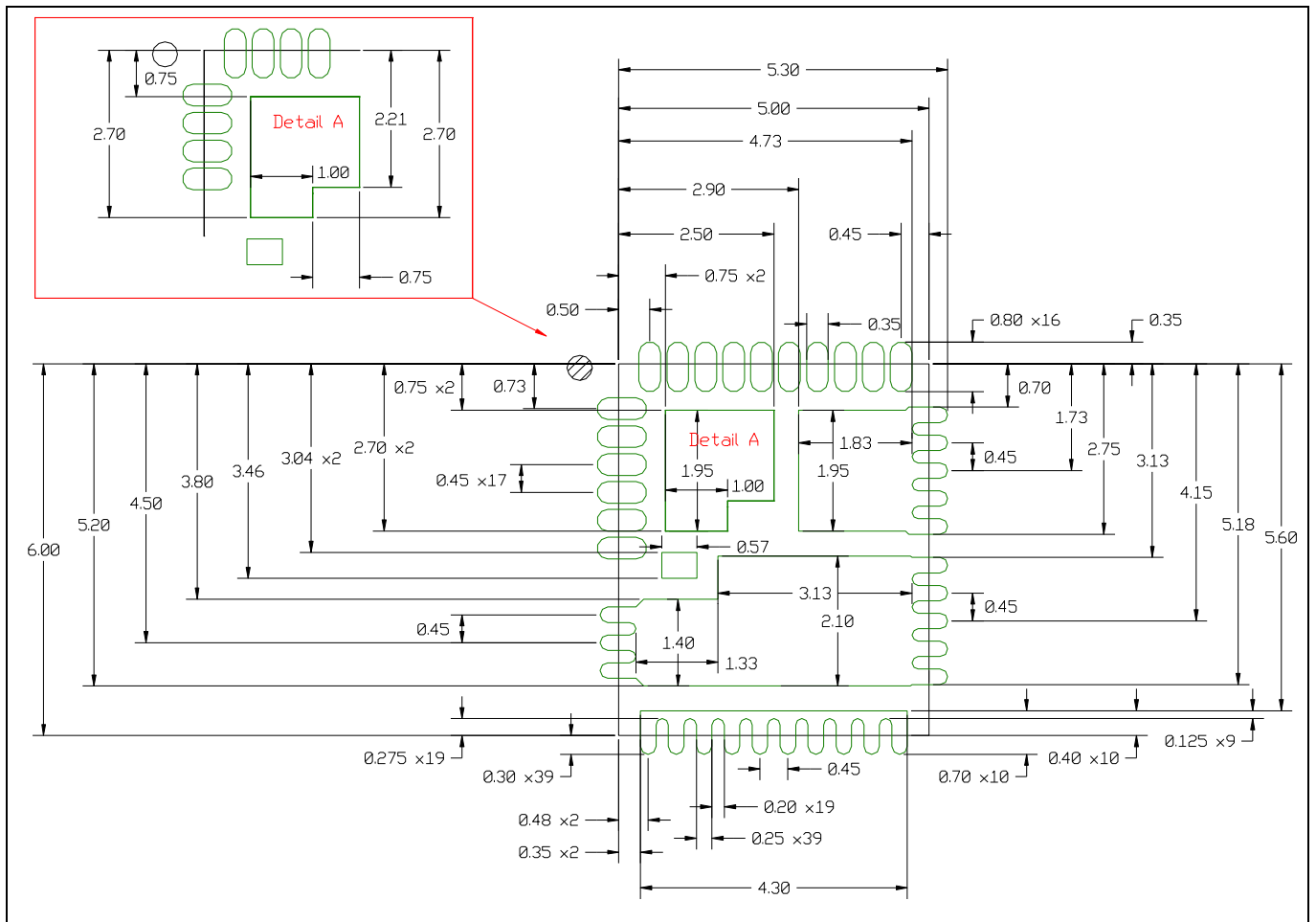

Figure 9 Solder Resist [Compatible with TDA2147x]





#### Trademarks of Infineon Technologies AG

$\mu$ HVIC™,  $\mu$ IPM™,  $\mu$ PFC™, AU-ConvertIR™, AURIX™, C166™, CanPAK™, CIPOS™, CIPURSE™, CoolDP™, CoolGaN™, COOLiR™, CoolMOS™, CoolSET™, CoolSiC™, DAVE™, DI-POL™, DirectFET™, DrBlade™, EasyPIM™, EconoBRIDGE™, EconoDUAL™, EconoPACK™, EconoPIM™, EiceDRIVER™, eupec™, FCOS™, GaNpowIR™, HEXFET™, HITFET™, HybridPACK™, iMOTION™, IRAM™, ISOFACE™, IsoPACK™, LEDrivr™, LITIX™, MIPAQ™, ModSTACK™, my-d™, NovalithIC™, OPTIGA™, OptiMOS™, ORIGA™, PowIRaudio™, PowIRStage™, PrimePACK™, PrimeSTACK™, PROFET™, PRO-SIL™, RASIC™, REAL3™, SmartLEWIS™, SOLID FLASH™, SPOC™, StrongIRFET™, SupIRBuck™, TEMPFET™, TRENCHSTOP™, TriCore™, UHVIC™, XHP™, XMC™

Trademarks updated November 2015

#### Other Trademarks

All referenced product or service names and trademarks are the property of their respective owners.

**Edition <2018-04-05><yyyy-mm-dd>**

**Published by**

**Infineon Technologies AG**

**81726 München, Germany**

**© 2021 Infineon Technologies AG.**

**All Rights Reserved.**

**Do you have a question about this document?**

**Email: [erratum@infineon.com](mailto:erratum@infineon.com)**

**Document reference**

#### IMPORTANT NOTICE

The information given in this document shall in no event be regarded as a guarantee of conditions or characteristics ("Beschaffheitsgarantie").

With respect to any examples, hints or any typical values stated herein and/or any information regarding the application of the product, Infineon Technologies hereby disclaims any and all warranties and liabilities of any kind, including without limitation warranties of non-infringement of intellectual property rights of any third party.

In addition, any information given in this document is subject to customer's compliance with its obligations stated in this document and any applicable legal requirements, norms and standards concerning customer's products and any use of the product of Infineon Technologies in customer's applications.

The data contained in this document is exclusively intended for technically trained staff. It is the responsibility of customer's technical departments to evaluate the suitability of the product for the intended application and the completeness of the product information given in this document with respect to such application.

For further information on the product, technology delivery terms and conditions and prices please contact your nearest Infineon Technologies office ([www.infineon.com](http://www.infineon.com)).



#### WARNINGS

Due to technical requirements products may contain dangerous substances. For information on the types in question please contact your nearest Infineon Technologies office.





Except as otherwise explicitly approved by Infineon Technologies in a written document signed by authorized representatives of Infineon Technologies, Infineon Technologies' products may not be used in any applications where a failure of the product or any consequences of the use thereof car reasonably be expected to result in personal injury.

## Looking for pricing, stock, or lifecycle information?

Click below to explore more details on WIN SOURCE:

-  [View TDA21570AUMA1](#) on WIN SOURCE
-  [Infineon Technologies](#) Information

## Optimize Your Supply Chain with WIN SOURCE Solutions

-  Global Sourcing Solution
-  Obsolete Management
-  Cost Control Management
-  Shortage Management
-  Alternative Solution
-  Excess Inventory Management