

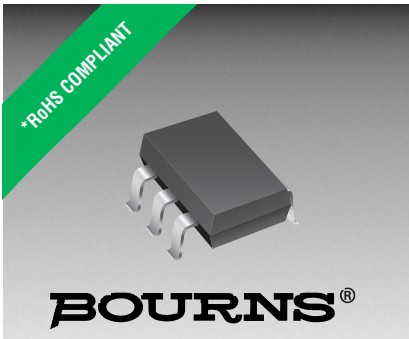

**THE DATASHEET OF  
CDSC706-0504C**





## Features

- Lead free as standard
- RoHS compliant\*
- Low capacitance - 1.3 pF
- ESD protection >25 kV
- Surge protection

## Applications

- Personal Digital Assistants (PDAs)
- Notebook and PC computers
- Memory card protection
- SIM card port protection
- Portable electronics

# CDSC706-0504C - Surface Mount TVS Diode Array

## General Information

The CDSC706-0504C device provides ESD, EFT and Surge protection for high speed data ports meeting IEC 61000-4-2 (ESD), IEC 61000-4-4 (EFT) and IEC 61000-4-5 (Surge) requirements. The Transient Voltage Suppressor array, protecting up to 4 data lines, offers a Working Peak Reverse Voltage of 5 V and Minimum Breakdown Voltage of 6 V.

The SC70-6L packaged device will mount directly onto the industry standard SC70-6 footprint. Bourns® Chip Diodes conform to JEDEC standards, are easy to handle with standard pick and place equipment and the flat configuration minimizes roll away.

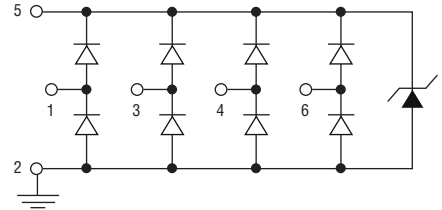

## Thermal Characteristics (@ T<sub>A</sub> = 25 °C Unless Otherwise Noted)

Parameter	Symbol	CDSC706-0504C	Unit
Peak Pulse Power (t <sub>p</sub> = 8/20 μs)	I <sub>PP</sub>	6.5	A
Storage Temperature	T <sub>STG</sub>	-55 to +150	°C
Operating Temperature	T <sub>OPR</sub>	-55 to +85	°C
Operating Supply Voltage	V <sub>DC</sub>	6	V
ESD per IEC61000-4-2 (Air) (I/O Pins)	V <sub>esd IO</sub>	18	kV
ESD per IEC61000-4-2 (Contact) (I/O Pins)		14	
ESD per IEC61000-4-2 (Air) (V <sub>CC</sub> to GND)	V <sub>esd VCC</sub>	30	kV
ESD per IEC61000-4-2 (Contact) (V <sub>CC</sub> to GND)		30	
DC Voltage at any I/O Pin	V <sub>IO</sub>	(GND-0.5) to (VCC+0.5)	V

## Electrical Characteristics (@ T<sub>A</sub> = 25 °C Unless Otherwise Noted)

Parameter	Symbol	CDSC706-0504C	Unit
Maximum Reverse Standoff Voltage <sup>1</sup>	V <sub>RWM</sub>	5.0	V
Maximum Leakage Current <sup>1</sup> @ V <sub>RWM</sub>	I <sub>L</sub>	5.0	μA
Maximum Channel Leakage Current @ V <sub>RWM</sub>	I <sub>CD</sub>	1.0	μA
Minimum Reverse Breakdown Voltage <sup>1</sup> @ I <sub>BV</sub> =1 mA	V <sub>BR</sub>	6.0	V
Maximum Forward Voltage <sup>4</sup> @ I <sub>F</sub> = 15 mA	V <sub>F</sub>	1.0	V
Maximum Clamping Voltage <sup>2</sup> @ 5 A 8/20 μs	V <sub>C</sub>	9.0	V
Typical ESD Clamping Voltage- I/O <sup>2</sup>	V <sub>clamp io</sub>	12.5	V
Maximum Channel Input Capacitance <sup>2</sup> @ V <sub>PIN5</sub> =5 V, V <sub>PIN2</sub> =0 V, V <sub>IN</sub> =2.5 V, f=1 MHz	C <sub>IN</sub>	1.6	pF
Max. Channel to Channel Input Capacitance <sup>3</sup> @ V <sub>PIN5</sub> =5 V, V <sub>PIN2</sub> =0 V, V <sub>IN</sub> =2.5 V, f=1 MHz	C <sub>CROSS</sub>	0.14	pF
Max. Variation of Channel Input Capacitance @ V <sub>PIN5</sub> =5 V, V <sub>PIN2</sub> =0 V, V <sub>IN</sub> =2.5 V, f=1 MHz (I/O Pin to GND)	ΔC <sub>IN</sub>	0.07	pF

**Notes:** 1: Pin 5 to Pin 2 (ground)  
2: Pin 1, 3, 4 or 6 to Pin 2 (ground)

3: Between any two of pins 1, 3, 4, 6.  
4: Pin 2 (ground) to Pin 5

# CDSC706-0504C - Surface Mount TVS Diode Array



## Product Dimensions

This is a molded JEDEC SC70-6L package with lead free 100 % Matte Sn on the lead frame. It weighs approximately 7 mg and has a flammability rating of UL 94V-0.

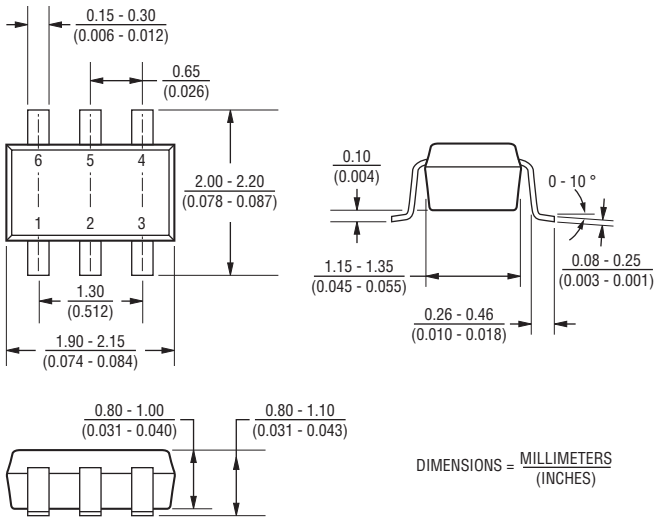

## Configuration

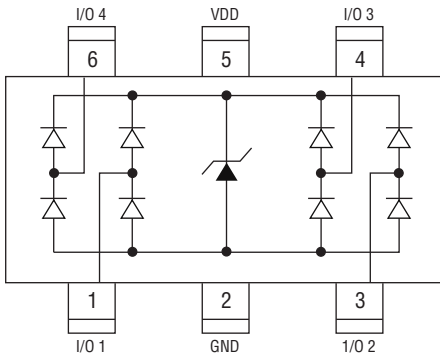

## Recommended Footprint

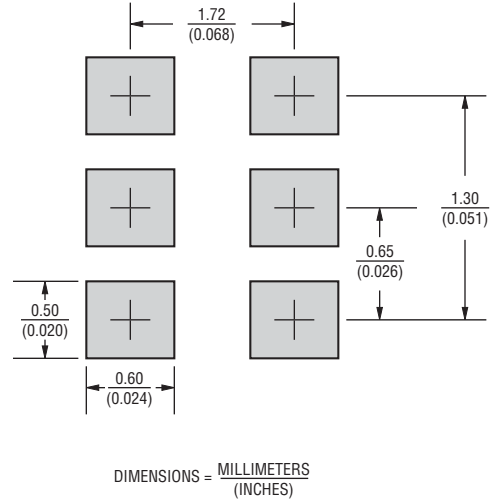

## Typical Part Marking

CDSC706-0504C.....C05

## How to Order

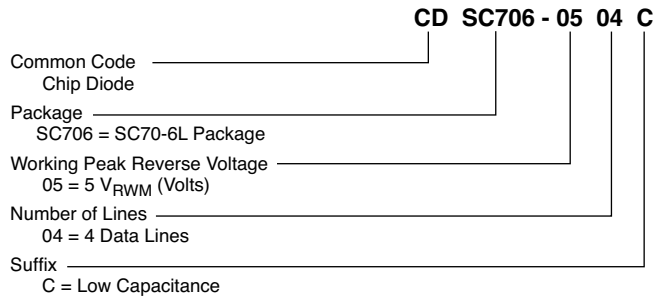

# CDSC706-0504C - Surface Mount TVS Diode Array



## Rating & Characteristic Curves

### Clamping Voltage vs. Peak Pulse Current

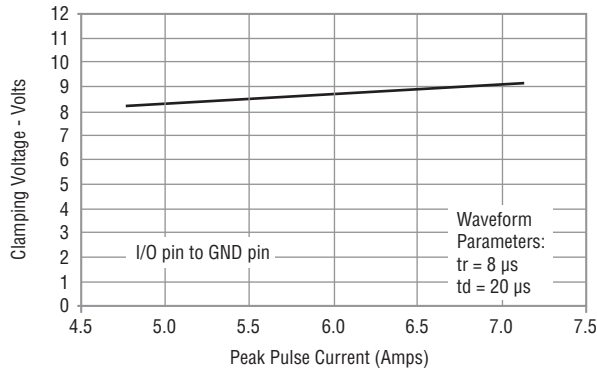

### Pulse Waveform

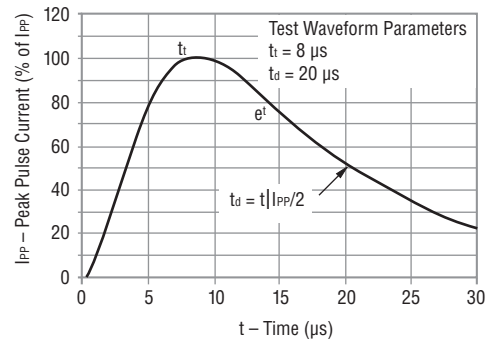

### Overshoot and Clamping Voltage

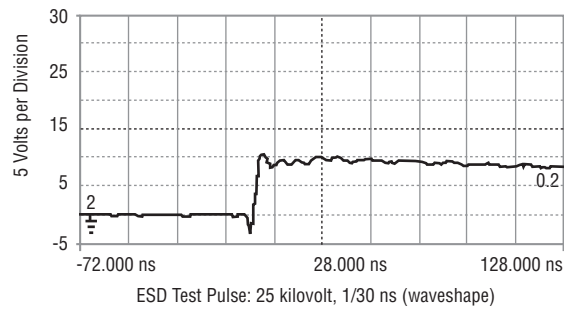

### Power Derating Curve

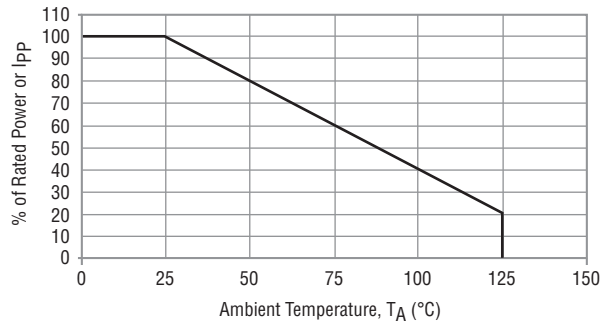

### Forward Voltage vs. Forward Current

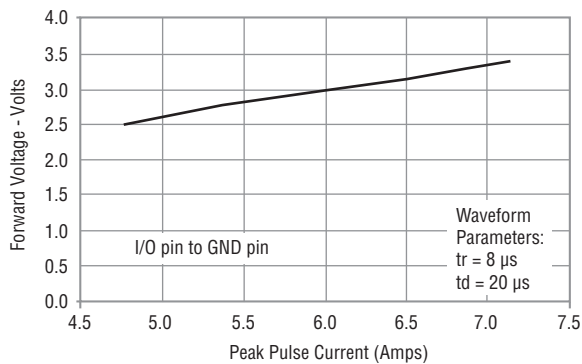

### Typical Variation of C<sub>IN</sub> vs. V<sub>IN</sub>

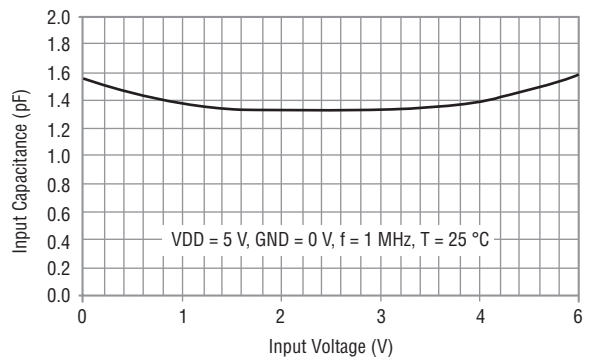

# CDSC706-0504C - Surface Mount TVS Diode Array

**BOURNS®**

## Packaging Information

The product is packaged in tape and reel format per EIA-481 Standard.

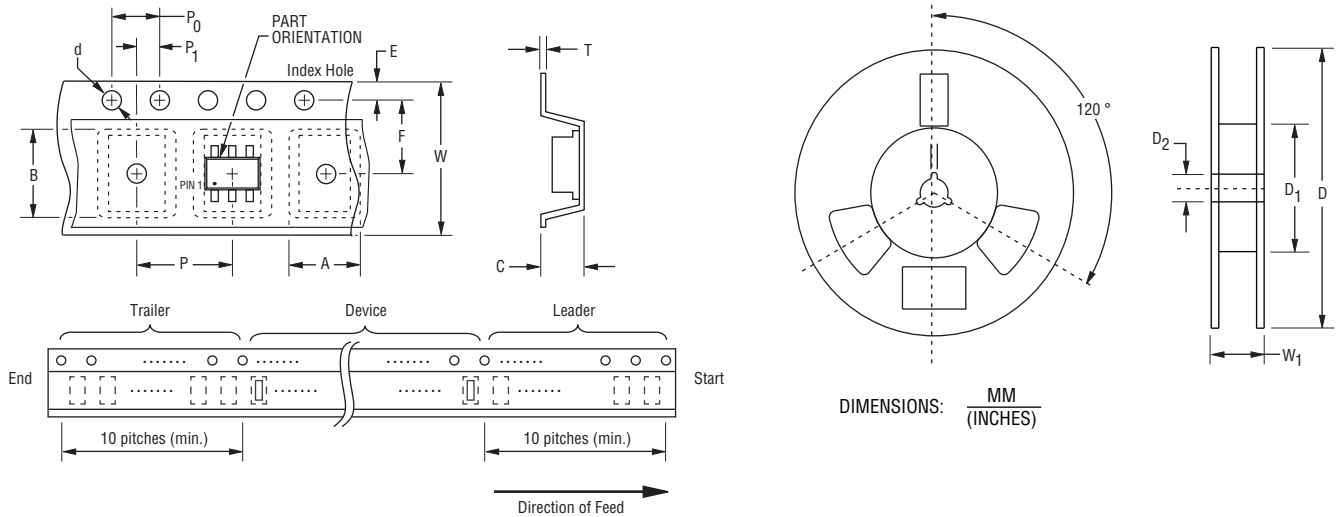

Item	Symbol	SC70-6L
Carrier Width	A	$\frac{2.25 \pm 0.10}{(0.088 \pm 0.004)}$
Carrier Length	B	$\frac{2.34 \pm 0.10}{(0.092 \pm 0.004)}$
Carrier Depth	C	$\frac{1.22 \pm 0.10}{(0.048 \pm 0.004)}$
Sprocket Hole	d	$\frac{1.55 \pm 0.05}{(0.061 \pm 0.002)}$
Reel Outside Diameter	D	$\frac{178}{(7.008)}$
Reel Inner Diameter	D <sub>1</sub>	$\frac{50.0}{(1.969)}$ MIN.
Feed Hole Diameter	D <sub>2</sub>	$\frac{13.0 \pm 0.20}{(0.512 \pm 0.008)}$
Sprocket Hole Position	E	$\frac{1.75 \pm 0.10}{(0.069 \pm 0.004)}$
Punch Hole Position	F	$\frac{3.50 \pm 0.05}{(0.138 \pm 0.002)}$
Punch Hole Pitch	P	$\frac{4.00 \pm 0.10}{(0.157 \pm 0.004)}$
Sprocket Hole Pitch	P <sub>0</sub>	$\frac{4.00 \pm 0.10}{(0.157 \pm 0.004)}$
Embossment Center	P <sub>1</sub>	$\frac{2.00 \pm 0.05}{(0.079 \pm 0.002)}$
Overall Tape Thickness	T	$\frac{0.20 \pm 0.10}{(0.008 \pm 0.004)}$
Tape Width	W	$\frac{8.00 \pm 0.20}{(0.315 \pm 0.008)}$
Reel Width	W <sub>1</sub>	$\frac{14.4}{(0.567)}$ MAX.
Quantity per Reel	--	3000

REV. 12/12

Specifications are subject to change without notice.  
Customers should verify actual device performance in their specific applications.

## Looking for pricing, stock, or lifecycle information?

Click below to explore more details on WIN SOURCE:

- ⊖ [View CDSC706-0504C on WIN SOURCE](#)
- ⊖ [Bourns Inc. Information](#)

## Optimize Your Supply Chain with WIN SOURCE Solutions

- ✓ Global Sourcing Solution
- ✓ Obsolete Management
- ✓ Cost Control Management
- ✓ Shortage Management
- ✓ Alternative Solution
- ✓ Excess Inventory Management