



**THE DATASHEET OF
TC297TP128F300NBCKXUMA1**



32-Bit

Microcontroller

TC290 / TC297 / TC298 / TC299

32-Bit Single-Chip Microcontroller
BC-Step

32-Bit Single-Chip Microcontroller

Data Sheet

V 1.1, 2019-03

Edition 2019-03

**Published by
Infineon Technologies AG
81726 Munich, Germany**

**© 2019 Infineon Technologies AG
All Rights Reserved.**

Legal Disclaimer

The information given in this document shall in no event be regarded as a guarantee of conditions or characteristics. With respect to any examples or hints given herein, any typical values stated herein and/or any information regarding the application of the device, Infineon Technologies hereby disclaims any and all warranties and liabilities of any kind, including without limitation, warranties of non-infringement of intellectual property rights of any third party.

Information

For further information on technology, delivery terms and conditions and prices, please contact the nearest Infineon Technologies Office (www.infineon.com)

Warnings

Due to technical requirements, components may contain dangerous substances. For information on the types in question, please contact the nearest Infineon Technologies Office.

Infineon Technologies components may be used in life-support devices or systems only with the express written approval of Infineon Technologies, if a failure of such components can reasonably be expected to cause the failure of that life-support device or system or to affect the safety or effectiveness of that device or system. Life support devices or systems are intended to be implanted in the human body or to support and/or maintain and sustain and/or protect human life. If they fail, it is reasonable to assume that the health of the user or other persons may be endangered.

Revision History

Page or Item	Subjects (major changes since previous revision)
V 1.1, 2019-03	
	The history is documented in the last chapter

Table of Contents

1	Summary of Features	4
2	Package and Pinning Definitions	8
2.1	TC299x Pin Definition and Functions: BGA516	9
2.1.1	TC299x BGA516 Package Variant Pin Configuration	10
2.1.2	Emergency Stop Function	120
2.1.3	Pull-Up/Pull-Down Reset Behavior of the Pins	121
2.2	TC298x Pin Definition and Functions: BGA416	122
2.2.1	TC298x BGA416 Package Variant Pin Configuration	123
2.2.2	Emergency Stop Function	220
2.2.3	Pull-Up/Pull-Down Reset Behavior of the Pins	221
2.3	TC297x Pin Definition and Functions: BGA292	222
2.3.1	TC297x BGA292 Package Variant Pin Configuration	223
2.3.2	Emergency Stop Function	293
2.3.3	Pull-Up/Pull-Down Reset Behavior of the Pins	293
2.4	TC29x Bare Die Pad Definition	295
2.4.1	Pad Openings	313
2.4.2	Emergency Stop Function	314
2.4.3	Pull-Up/Pull-Down Reset Behavior of the Pins	314
3	Electrical Specification	316
3.1	Parameter Interpretation	316
3.2	Absolute Maximum Ratings	317
3.3	Pin Reliability in Overload	318
3.4	Operating Conditions	322
3.5	5 V / 3.3 V switchable Pads	325
3.6	High performance LVDS Pads (LVDSH)	345
3.7	Medium performance LVDS Pads (LVDSM)	349
3.8	VADC Parameters	350
3.9	DSADC Parameters	356
3.10	MHz Oscillator	361
3.11	Back-up Clock	362
3.12	Temperature Sensor	363
3.13	Power Supply Current	364
3.13.1	Calculating the 1.3 V Current Consumption	369
3.14	Power-up and Power-down	371
3.14.1	External Supply Mode	371
3.14.2	Single Supply Mode	373
3.14.3	External Supply Mode	375
3.14.4	Single Supply Mode	377
3.15	Reset Timing	379
3.16	EVR	381
3.17	Phase Locked Loop (PLL)	386
3.18	ERAY Phase Locked Loop (ERAY_PLL)	387
3.19	AC Specifications	388
3.20	JTAG Parameters	389
3.21	DAP Parameters	391
3.22	ASCLIN SPI Master Timing	393
3.23	ASCLIN SPI Master Timing	397
3.24	QSPI Timings, Master and Slave Mode	401

3.25	QSPI Timings, Master and Slave Mode	406
3.26	MSC Timing 5 V Operation	413
3.27	MSC Timing 3.3 V Operation	418
3.28	Ethernet Interface (ETH) Characteristics	423
3.28.1	ETH Measurement Reference Points	423
3.28.2	ETH Management Signal Parameters (ETH_MDC, ETH_MDIO)	424
3.28.3	ETH MII Parameters	425
3.28.4	ETH RMII Parameters	426
3.29	E-Ray Parameters	427
3.30	HSCT Parameters	429
3.31	Inter-IC (I2C) Interface Timing	432
3.32	EBU Timings	435
3.32.1	BFCLKO Output Clock Timing	435
3.32.2	EBU Asynchronous Timings	435
3.32.3	EBU Burst Mode Access Timing	439
3.32.4	EBU Arbitration Signal Timing	441
3.33	CIF Parameters	442
3.34	Flash Target Parameters	448
3.35	Package Outline	451
3.35.1	Package Parameters	452
3.35.2	TC290 Carrier Tape	452
3.36	Quality Declarations	454
4	History	455
4.1	Changes from TC29xBB_v1.1 to TC29xBC_v1.0	455
4.2	Changes from v1.0 to v1.1	455

Trademarks of Infineon Technologies AG

AURIX™, C166™, CanPAK™, CIPOS™, CIPURSE™, EconoPACK™, CoolMOS™, CoolSET™, CORECONTROL™, CROSSAVE™, DAVE™, DI-POL™, EasyPIM™, EconoBRIDGE™, EconoDUAL™, EconoPIM™, EconoPACK™, EiceDRIVER™, eupec™, FCOS™, HITFET™, HybridPACK™, I²RF™, ISOFACE™, IsoPACK™, MIPAQ™, ModSTACK™, my-d™, NovalithIC™, OptiMOS™, ORIGA™, POWERCODE™; PRIMARION™, PrimePACK™, PrimeSTACK™, PRO-SIL™, PROFET™, RASIC™, ReverSave™, SatRIC™, SIEGET™, SINDRION™, SIPMOS™, SmartLEWIS™, SOLID FLASH™, TEMPFET™, thinQ!™, TRENCHSTOP™, TriCore™.

Other Trademarks

Advance Design System™ (ADS) of Agilent Technologies, AMBA™, ARM™, MULTI-ICE™, KEIL™, PRIMECELL™, REALVIEW™, THUMB™, μ Vision™ of ARM Limited, UK. AUTOSAR™ is licensed by AUTOSAR development partnership. Bluetooth™ of Bluetooth SIG Inc. CAT-iq™ of DECT Forum. COLOSSUS™, FirstGPS™ of Trimble Navigation Ltd. EMV™ of EMVCo, LLC (Visa Holdings Inc.). EPCOS™ of Epcos AG. FLEXGO™ of Microsoft Corporation. FlexRay™ is licensed by FlexRay Consortium. HYPERTERMINAL™ of Hilgraeve Incorporated. IEC™ of Commission Electrotechnique Internationale. IrDA™ of Infrared Data Association Corporation. ISO™ of INTERNATIONAL ORGANIZATION FOR STANDARDIZATION. MATLAB™ of MathWorks, Inc. MAXIM™ of Maxim Integrated Products, Inc. MICROTEC™, NUCLEUS™ of Mentor Graphics Corporation. MIPI™ of MIPI Alliance, Inc. MIPS™ of MIPS Technologies, Inc., USA. muRata™ of MURATA MANUFACTURING CO., MICROWAVE OFFICE™ (MWO) of Applied Wave Research Inc., OmniVision™ of OmniVision Technologies, Inc. Openwave™ Openwave Systems Inc. RED HAT™ Red Hat, Inc. RFMD™ RF Micro Devices, Inc. SIRIUS™ of Sirius Satellite Radio Inc. SOLARIS™ of Sun Microsystems, Inc. SPANSION™ of Spansion LLC Ltd. Symbian™ of Symbian Software Limited. TAIYO YUDEN™ of Taiyo Yuden Co. TEAKLITE™ of CEVA, Inc. TEKTRONIX™ of Tektronix Inc. TOKO™ of TOKO KABUSHIKI KAISHA TA. UNIX™ of X/Open Company Limited. VERILOG™, PALLADIUM™ of Cadence Design Systems, Inc. VLYNQ™ of Texas Instruments Incorporated. VXWORKS™, WIND RIVER™ of WIND RIVER SYSTEMS, INC. ZETEX™ of Diodes Zetex Limited.

Last Trademarks Update 2011-11-11

1 Summary of Features

The TC29x product family has the following features:

- High Performance Microcontroller with three CPU cores
- Two 32-bit super-scalar TriCore CPUs (TC1.6P), each having the following features:
 - Superior real-time performance
 - Strong bit handling
 - Fully integrated DSP capabilities
 - Multiply-accumulate unit able to sustain 2 MAC operations per cycle
 - up to 300 MHz operation at full temperature range
 - up to 120 / 240 Kbyte Data Scratch-Pad RAM (DSPR)
 - up to 32 Kbyte Instruction Scratch-Pad RAM (PSPR)
 - 16 / 32 Kbyte Instruction Cache (ICACHE)
 - 8 Kbyte Data Cache (DCACHE)
- Lockstepped shadow cores for TC1.6P core 1
- Multiple on-chip memories
 - All embedded NVM and SRAM are ECC protected
 - up to 8 Mbyte Program Flash Memory (PFLASH)
 - up to 768 Kbyte Data Flash Memory (DFLASH) usable for EEPROM emulation
 - 32 Kbyte Memory (LMU)
 - BootROM (BROM)
- 128-Channel DMA Controller with safe data transfer
- Sophisticated interrupt system (ECC protected)
- High performance on-chip bus structure
 - 64-bit Cross Bar Interconnect (SRI) giving fast parallel access between bus masters, CPUs and memories
 - 32-bit System Peripheral Bus (SPB) for on-chip peripheral and functional units
 - One bus bridge (SFI Bridge)
- Safety Management Unit (SMU) handling safety monitor alarms
- Memory Test Unit with ECC, Memory Initialization and MBIST functions (MTU)
- Hardware I/O Monitor (IOM) for checking of digital I/O
- Versatile On-chip Peripheral Units
 - Four Asynchronous/Synchronous Serial Channels (ASCLIN) with hardware LIN support (V1.3, V2.0, V2.1 and J2602) up to 50 MBaud
 - Six Queued SPI Interface Channels (QSPI) with master and slave capability up to 50 Mbit/s
 - High Speed Serial Link (HSSL) for serial inter-processor communication up to 320 Mbit/s
 - Two serial Micro Second Bus interfaces (MSC) for serial port expansion to external power devices
 - Two MultiCAN+ Module with 6 CAN nodes and 384 free assignable message objects for high efficiency data handling via FIFO buffering and gateway data transfer
 - 15 Single Edge Nibble Transmission (SENT) channels for connection to sensors
 - Up to two FlexRay™ modules with 2 channels (E-Ray) supporting V2.1
 - One Generic Timer Module (GTM) providing a powerful set of digital signal filtering and timer functionality to realize autonomous and complex Input/Output management
 - One Capture / Compare 6 module (Two kernels CCU60 and CCU61)

- One General Purpose 12 Timer Unit (GPT120)
- Five channel Peripheral Sensor Interface conforming to V1.3 (PSI5)
- Peripheral Sensor Interface with Serial PHY (PSI5-S)
- Inter-Integrated Circuit Bus Interface (I2C) conforming to V2.1
- Optional IEEE802.3 Ethernet MAC with RMI and MII interfaces (ETH)
- Versatile Successive Approximation ADC (VADC)
 - Cluster of 11 independent ADC kernels
 - Input voltage range from 0v to 5.5V (ADC supply)
- Delta-Sigma ADC (DSADC)
 - Ten channels
- Digital programmable I/O ports
- On-chip debug support for OCDS Level 1 (CPUs, DMA, On Chip Buses)
- Dedicated Emulation Device chip available
 - multi-core debugging, real time tracing, and calibration
 - Aurora Gigabit Trace Port (AGBT) on some variants
 - four/five wire JTAG (IEEE 1149.1) or DAP (Device Access Port) interface
- Power Management System and on-chip regulators
- Clock Generation Unit with System PLL and Flexray PLL
- Embedded Voltage Regulator

Ordering Information

The ordering code for Infineon microcontrollers provides an exact reference to the required product. This ordering code identifies:

- The derivative itself, i.e. its function set, the temperature range, and the supply voltage
- The package and the type of delivery.

For the available ordering codes for the TC290 / TC297 / TC298 / TC299 please refer to the “**AURIX™ TC2xx Data Sheet Addendum**”, which summarizes all available variants.

Table 1-1 Overview of TC27x Functions

Feature		
CPU Core	Type	TC1.6P
	P Cores / Checker Cores	3 / 1
	Max. Freq.	300 MHz
	FPU	yes
Program Flash	Size	8 Mbyte
Data Flash	Size	768 Kbyte
Cache	Instruction (P / E)	16 / 32 / 32 Kbyte
	Data (P / E)	8 Kbyte
SRAM	Size TC1.6P (DSPR/PSPR)	120 Kbyte / 32 Kbyte ^{1) 2)} 240Kbyte / 32 Kbyte 240 Kbyte / 32 Kbyte
	Size LMU	32 Kbyte
DMA	Channels	128
ADC	Channels	72 + 12
	Converter	11
DSADC	Channels	10
GTM	TIM	6
	TOM	5
	ATOM / MCS	9 / 6
	CMU / ICM	1 / 1
	PSM	2
	TBU	1
	SPE	4
	CMP / MON	1 / 1
	BRC / DPLL	1 / 1
Timer	GPT12	1
	CCU6	2
STM	Modules	3
FlexRay	Modules	2
	Channels	4
CAN	Nodes	6
	Message Objects	384

Table 1-1 Overview of TC27x Functions (cont'd)

Feature		
QSPI	Channels	6
ASCLIN	Interfaces	4
I2C	Interfaces	2
SENT	Channels	15
PSI5	Modules	5
PSI5-S	Modules	1
HSSL	Channels	1
MSC	Channels	3
Ethernet	Channels	1
ASIL	Level	up to ASIL-D
FCE	Modules	1
Safety support	SMU	1
	IOM	1
Security	HSM	1
ADAS		Yes
Embedded Voltage Regulator	DCDC from 5 V / 3.3 V to 1.3 V	Yes
Embedded Voltage Regulator	LDO from 5 V / 3.3 V to 1.3 V	Yes
Embedded Voltage Regulator	LDO from 5 V to 3.3 V	Yes
Low Power Feature	Standby RAM	Yes
Packages	Type	LF-BGA-292-6 / LF-BGA-292-10 / PG-BGA-416-26 / PG-BGA-416-29 / PG-LFBGA-516-5 / PG-LFBGA-516-10
I/O	Type	5 V CMOS / 3.3 V CMOS / LVDS
T _{ambient}	Range	-40 ... +125°C

- 1) Address range starts at lowest address defined in the User's Manual. For reference see the Memory Maps chapter of the User's Manual.
- 2) To ensure the processor cores are provided with a constant stream of instructions the Instruction Fetch Units will speculatively fetch instructions from the up to 64 bytes ahead of the current PC.
If the current PC is within 64 bytes of the top of an instruction memory the Instruction Fetch Unit may attempt to speculatively fetch instruction from beyond the physical range. This may then lead to error conditions and alarms being triggered by the bus and memory systems.
It is therefore recommended that the upper 64 bytes of any memory be unused for instruction storage.

2 Package and Pinning Definitions

This chapter gives a pinning of the different packages of the TC290 / TC297 / TC298 / TC299.

Package and Pinning Definitions TC299x Pin Definition and Functions:

2.1 TC299x Pin Definition and Functions: BGA516

Figure 2-1 is showing the TC299x Logic Symbol for the package variant: BGA516.

30	29	28	27	26	25	24	23	22	21	20	19	18	17	16	15	14	13	12	11	10	9	8	7	6	5	4	3	2	1			
AK	VSS	VFLEXE	P30.15	P30.13	P30.11	P30.9	P30.7	P30.5	P30.3	P30.1	VFLEXE	P31.15	P31.13	P31.11	P31.9	P31.7	P31.5	P31.3	P31.1	VFLEXE	VSS	VDDM	VSSM	AN48	AN51	AN53	AN55	NC	NC	NC	AK	
AJ	VEXT	VSS	P30.14	P30.12	P30.10	P30.8	P30.6	P30.4	P30.2	P30.0	VGATE3P	P31.14	P31.12	P31.10	P31.8	P31.6	P31.4	P31.2	P31.0	VFLEXE	VSS	VDDM	VSSM	AN49	AN50	AN52	AN54	NC	NC	NC	AJ	
AH	VEBU	VEXT																												NC	NC	AH
AG	P25.0	P26.0																												NC	NC	AG
AF	P25.1	P25.2																												AN57	AN56	AF
AE	P25.3	P25.4																												AN58	AN59	AE
AD	P25.5	P25.7																												AN61	AN60	AD
AC	P25.9	P25.8																												AN62	AN63	AC
AB	P25.11	P25.10																												AN64	AN65	AB
AA	P25.13	P25.12																												AN66	AN67	AA
Y	P25.15	P25.14																												AN69	AN68	Y
W	NC	P25.6																												AN71	AN70	W
V	NC	NC																												NC	NC	V
U	P24.1	P24.0																												P00.14	P00.15	U
T	P24.3	P24.2																												P00.13	NC	T
R	P24.5	P24.4																												NC	NC	R
P	P24.7	P24.6																												P01.14	P01.15	P
N	P24.9	P24.8																												P01.12	P01.13	N
M	P24.11	P24.10																												P01.10	P01.11	M
L	P24.13	P24.12																												P01.9	P01.8	L
K	P24.15	P24.14																												P01.2	P01.1	K
J	VEBU	VEBU																												P01.0	NC	J
H	VSS	VSS																												NC	NC	H
G	NC	NC																												P02.14	P02.15	G
F	NC	NC																												P02.12	P02.13	F
E	NC	NC																												NC	NC	E
D	NC	NC																												NC	NC	D
C	NC	NC																												NC	NC	C
B	VSS	VSS	VDDP3	NC	NC	NC	P15.10	P15.12	P15.14	NC	NC	P14.12	P14.14	NC	P13.4	P13.6	NC	P13.10	P13.12	P13.14	NC	NC	P10.9	P10.10	NC	P10.14	NC	VEXT	VSS	NC	B	
A	VSS	VDDP3	NC	NC	NC	NC	P15.11	P15.13	P15.15	NC	P14.11	P14.13	P14.15	NC	P13.5	P13.7	P13.9	P13.11	P13.13	P13.15	NC	NC	NC	P10.11	P10.13	P10.15	NC	NC	VEXT	NC	A	

Figure 2-1 TC299x Logic Symbol for the package variant BGA516.

2.1.1 TC299x BGA516 Package Variant Pin Configuration

Table 2-1 Port 00 Functions

Pin	Symbol	Ctrl	Type	Function
M6	P00.0	I	MP / PU1 / VEXT	General-purpose input
	TIN9			GTM input
	CTRAPA			CCU61 input
	T12HRE			CCU60 input
	INJ00			MSC0 input
	CIFD9			CIF input
	P00.0			O0
	TOUT9	O1		GTM output
	ASCLK3	O2		ASCLIN3 output
	ATX3	O3		ASCLIN3 output
	–	O4		Reserved
	TXDCAN1	O5		CAN node 1 output
	–	O6		Reserved
	COU63	O7		CCU60 output
	ETHMDIOA	HWOUT		ETH input/output

Package and Pinning Definitions TC299x Pin Definition and Functions:
Table 2-1 Port 00 Functions (cont'd)

Pin	Symbol	Ctrl	Type	Function
M7	P00.1	I	LP / PU1 / VEXT	General-purpose input
	TIN10			GTM input
	ARX3E			ASCLIN3 input
	RXDCAN1D			CAN node 1 input
	PSIRX0A			PSI5 input
	SENT0B			SENT input
	CC60INB			CCU60 input
	CC60INA			CCU61 input
	DSCIN5A			DSADC channel 5 input
	DS5NA			DSADC positive analog input of channel channel 5, pin A
	DSCIN7B			DSADC channel 7 input
	VADCG7.5			VADC analog input channel 5 of group 7
	CIFD10			CIF input
	P00.1			O0
	TOUT10	O1	GTM output	
	ATX3	O2	ASCLIN3 output	
	-	O3	Reserved	
	DSCOUT5	O4	DSADC channel 5 output	
	DSCOUT7	O5	DSADC channel 7 output	
	SPC0	O6	SENT output	
CC60	O7	CCU61 output		
N6	P00.2	I	LP / PU1 / VEXT	General-purpose input
	TIN11			GTM input
	SENT1B			SENT input
	DSDIN5A			DSADC channel 5 input
	DSDIN7B			DSADC channel 7 input
	DS5PA			DSADC negative analog input of channel 5, pin A
	VADCG7.4			VADC analog input channel 4 of group 7
	CIFD11			CIF input
	P00.2	O0	General-purpose output	
	TOUT11	O1	GTM output	
	ASCLK3	O2	ASCLIN3 output	
	TXDCANr1	O3	CAN node 1 output (MultiCANr+)	
	PSITX0	O4	PSI5 output	
	TXDCAN3	O5	CAN node 3 output	
	SLSO34	O6	QSPI3 output	
	COUT60	O7	CCU61 output	

Package and Pinning Definitions TC299x Pin Definition and Functions:

Table 2-1 Port 00 Functions (cont'd)

Pin	Symbol	Ctrl	Type	Function	
N7	P00.3	I	LP / PU1 / VEXT	General-purpose input	
	TIN12			GTM input	
	RXDCAN3A			CAN node 3 input	
	RXDCANr1A			CAN node 1 input (MultiCANr+)	
	PSIRX1A			PSI5 input	
	PSISRXA			PSI5-S input	
	SENT2B			SENT input	
	CC61INB			CCU60 input	
	CC61INA			CCU61 input	
	DSCIN3A			DSADC channel 3 input	
	VADCG7.3			VADC analog input channel 3 of group 7	
	DSITR5F			DSADC channel 5 input	
	CIFD12			CIF input	
	P00.3	O0	General-purpose output		
	TOUT12	O1	GTM output		
	ASLSO3	O2	ASCLIN3 output		
	–	O3	Reserved		
	DSCOUT3	O4	DSADC channel 3 output		
	–	O5	Reserved		
	SPC2	O6	SENT output		
CC61	O7	CCU61 output			
P6	P00.4	I	LP / PU1 / VEXT	General-purpose input	
	TIN13			GTM input	
	REQ7			SCU input	
	SENT3B			SENT input	
	DSDIN3A			DSADC channel 3 input	
	DSSGNA			DSADC channel input	
	VADCG7.2			VADC analog input channel 2 of group 7	
	CIFD13			CIF input	
	P00.4			O0	General-purpose output
	TOUT13			O1	GTM output
	PSISTX	O2	PSI5-S output		
	–	O3	Reserved		
	PSITX1	O4	PSI5 output		
	VADCG4BFL0	O5	VADC output		
	SPC3	O6	SENT output		
	COUT61	O7	CCU61 output		

Package and Pinning Definitions TC299x Pin Definition and Functions:
Table 2-1 Port 00 Functions (cont'd)

Pin	Symbol	Ctrl	Type	Function
P7	P00.5	I	LP / PU1 / VEXT	General-purpose input
	TIN14			GTM input
	PSIRX2A			PSI5 input
	SENT4B			SENT input
	CC62INB			CCU60 input
	CC62INA			CCU61 input
	DSCIN2A			DSADC channel 2 input
	VADCG7.1			VADC analog input channel 1 of group 7
	CIFD14			CIF input
	P00.5	O0		General-purpose output
	TOUT14	O1		GTM output
	DSCGPWMN	O2		DSADC output
	SLSO33	O3		QSPI3 output
	DSCOUT2	O4		DSADC channel 2 output
	VADCG4BFL1	O5		VADC output
	SPC4	O6		SENT output
	CC62	O7		CCU61 output
P9	P00.6	I	LP / PU1 / VEXT	General-purpose input
	TIN15			GTM input
	SENT5B			SENT input
	DSDIN2A			DSADC channel 2 input A
	VADCG7.0			VADC analog input channel 0 of group 7 (with pull down diagnostics)
	DSITR4F			DSADC channel 4 input F
	CIFD15	CIF input		
	P00.6	O0		General-purpose output
	TOUT15	O1		GTM output
	DSCGPWMP	O2		DSADC output
	VADCG4BFL2	O3		VADC output
	PSITX2	O4		PSI5 output
	VADCEMUX10	O5		VADC output
	SPC5	O6		SENT output
	COOUT62	O7		CCU61 output

Package and Pinning Definitions TC299x Pin Definition and Functions:

Table 2-1 Port 00 Functions (cont'd)

Pin	Symbol	Ctrl	Type	Function
R6	P00.7	I	LP / PU1 / VEXT	General-purpose input
	TIN16			GTM input
	SENT6B			SENT input
	CC60INC			CCU61 input
	CCPOS0A			CCU61 input
	T12HRB			CCU60 input
	T2INA			GPT120 input
	DSCIN4A			DSADC channel 4 input A
	DS4NA			DSADC negative analog input channel 4, pin A
	VADCG6.5			VADC analog input channel 5 of group 6
	CIFCLK			CIF input
	P00.7			O0
	TOUT16	O1		GTM output
	–	O2		Reserved
	VADCG4BFL3	O3		VADC output
	DSCOUT4	O4		DSADC channel 4 output
	VADCEMUX11	O5		VADC output
	SPC6	O6		SENT output
	CC60	O7		CCU61 output
R9	P00.8	I	LP / PU1 / VEXT	General-purpose input
	TIN17			GTM input
	SENT7B			SENT input
	CC61INC			CCU61 input
	CCPOS1A			CCU61 input
	T13HRB			CCU60 input
	T2EUDA			GPT120 input
	DSDIN4A			DSADC channel 4 input A
	DS4PA			DSADC positive analog input of channel 4, pin A
	VADCG6.4			VADC analog input channel 4 of group 6
	CIFVSNC			CIF input
	P00.8			O0
	TOUT17	O1		GTM output
	SLSO36	O2		QSPI3 output
	–	O3		Reserved
	–	O4		Reserved
	VADCEMUX12	O5		VADC output
	SPC7	O6		SENT output
	CC61	O7		CCU61 output

Package and Pinning Definitions TC299x Pin Definition and Functions:

Table 2-1 Port 00 Functions (cont'd)

Pin	Symbol	Ctrl	Type	Function
R7	P00.9	I	LP / PU1 / VEXT	General-purpose input
	TIN18			GTM input
	SENT8B			SENT input
	CC62INC			CCU61 input
	CCPOS2A			CCU61 input
	T13HRC			CCU60 input
	T12HRC			CCU60 input
	T4EUDA			GPT120 input
	DSCIN1A			DSADC channel 1 input A
	VADCG6.3			VADC analog input channel 3 of group 6
	DSITR3F			DSADC channel 3 input F
	CIFHSNC			CIF input
	P00.9			O0
	TOUT18	O1		GTM output
	SLSO37	O2		QSPI3 output
	ARTS3	O3		ASCLIN3 output
	DSCOUT1	O4		DSADC channel 1 output
	–	O5		Reserved
	SPC8	O6		SENT output
CC62	O7	CCU61 output		
R10	P00.10	I	LP / PU1 / VEXT	General-purpose input
	TIN19			GTM input
	SENT9B			SENT input
	DSDIN1A			DSADC channel 1 input A
	VADCG6.2			VADC analog input channel 2 of group 6
	P00.10	O0		General-purpose output
	TOUT19	O1		GTM output
	–	O2		Reserved
	–	O3		Reserved
	–	O4		Reserved
	–	O5		Reserved
	SPC9	O6		SENT output
	COU63	O7		CCU61 output

Package and Pinning Definitions TC299x Pin Definition and Functions:
Table 2-1 Port 00 Functions (cont'd)

Pin	Symbol	Ctrl	Type	Function
T6	P00.11	I	LP / PU1 / VEXT	General-purpose input
	TIN20			GTM input
	CTRAPA			CCU60 input
	T12HRE			CCU61 input
	DSCIN0A			DSADC channel 0 input A
	VADCG6.1			VADC analog input channel 1 of group 6
	P00.11			O0
	TOUT20	O1		GTM output
	—	O2		Reserved
	—	O3		Reserved
	DSCOUT0	O4		DSADC channel 0 output
	—	O5		Reserved
	—	O6		Reserved
	—	O7		Reserved
T7	P00.12	I	LP / PU1 / VEXT	General-purpose input
	TIN21			GTM input
	ACTS3A			ASCLIN3 input
	DSDIN0A			DSADC channel 0 input A
	VADCG6.0			VADC analog input channel 0 of group 6
	P00.12	O0		General-purpose output
	TOUT21	O1		GTM output
	—	O2		Reserved
	—	O3		Reserved
	—	O4		Reserved
	—	O5		Reserved
	—	O6		Reserved
COOUT63	O7	CCU61 output		
T2	P00.13	I	MP+ / PU1 / VEXT	General-purpose input
	TIN167			GTM input
	DSDIN6A			DSADC channel 6 input A
	P00.13	O0		General-purpose output
	TOUT167	O1		GTM output
	—	O2		Reserved
	—	O3		Reserved
	EXTCLK1	O4		SCU output
	—	O5		Reserved
	—	O6		Reserved
	—	O7		Reserved

Package and Pinning Definitions TC299x Pin Definition and Functions:
Table 2-1 Port 00 Functions (cont'd)

Pin	Symbol	Ctrl	Type	Function
U2	P00.14	I	LP / PU1 / VEXT	General-purpose input
	TIN166			GTM input
	DSCIN6A			DSADC channel 6 input A
	P00.14	O0		General-purpose output
	TOUT166	O1		GTM output
	—	O2		Reserved
	—	O3		Reserved
	DSCOUT6	O4		DSADC channel 6 output
	—	O5		Reserved
	—	O6		Reserved
—	O7	Reserved		
U1	P00.15	I	MP+ / PU1 / VEXT	General-purpose input
	TIN168			GTM input
	DSITR6F			DSADC channel 6 input F
	P00.15	O0		General-purpose output
	TOUT168	O1		GTM output
	—	O2		Reserved
	—	O3		Reserved
	EXTCLK0	O4		SCU output
	—	O5		Reserved
	—	O6		Reserved
—	O7	Reserved		

Table 2-2 Port 01 Functions

Pin	Symbol	Ctrl	Type	Function
J2	P01.0	I	LP / PU1 / VEXT	General-purpose input
	TIN155			GTM input
	DSITR6E			DSADC channel 6 input E
	RXDCAN3F			CAN node 3 input
	RXDCANr1E			CAN node 1 input (MultiCANr+)
	P01.0	O0		General-purpose output
	TOUT155	O1		GTM output
	—	O2		Reserved
	—	O3		Reserved
	—	O4		Reserved
	—	O5		Reserved
	—	O6		Reserved
—	O7	Reserved		

Package and Pinning Definitions TC299x Pin Definition and Functions:

Table 2-2 Port 01 Functions (cont'd)

Pin	Symbol	Ctrl	Type	Function
K1	P01.1	I	LP / PU1 / VEXT	General-purpose input
	TIN159			GTM input
	DSITR8E			DSADC channel 8 input E
	RXD1A1			ERAY1 input
	SENT10B			SENT input
	P01.1	O0		General-purpose output
	TOUT159	O1		GTM output
	–	O2		Reserved
	–	O3		Reserved
	–	O4		Reserved
	–	O5		Reserved
	–	O6		Reserved
	–	O7		Reserved
	K2	P01.2		I
TIN156		GTM input		
DSCIN7A		DSADC channel 7 input A		
P01.2		O0	General-purpose output	
TOUT156		O1	GTM output	
–		O2	Reserved	
TXDCAN3		O3	CAN node 3 output	
–		O4	Reserved	
TXDCANr1		O5	CAN node 1 output (MultiCANr+)	
DSCOUT7		O6	DSADC channel 7 output	
–		O7	Reserved	
M10	P01.3	I	LP / PU1 / VEXT	General-purpose input
	TIN111			GTM input
	SLSI3B			QSPI3 input
	DSITR7F			DSADC channel 7 input F
	P01.3	O0		General-purpose output
	TOUT111	O1		GTM output
	–	O2		Reserved
	–	O3		Reserved
	SLSO39	O4		QSPI3 output
	TXDCAN1	O5		CAN node 1 output
	–	O6		Reserved
	–	O7		Reserved

Package and Pinning Definitions TC299x Pin Definition and Functions:

Table 2-2 Port 01 Functions (cont'd)

Pin	Symbol	Ctrl	Type	Function
M9	P01.4	I	LP / PU1 / VEXT	General-purpose input
	TIN112			GTM input
	RXDCAN1C			CAN node 1 input
	DSITR7E			DSADC channel 7 input E
	P01.4	O0		General-purpose output
	TOUT112	O1		GTM output
	–	O2		Reserved
	–	O3		Reserved
	SLSO310	O4		QSPI3 output
	–	O5		Reserved
	–	O6		Reserved
	–	O7		Reserved
N10	P01.5	I	LP / PU1 / VEXT	General-purpose input
	TIN113			GTM input
	MRST3C			QSPI3 input
	DSCIN8A			DSADC channel 8 input A
	P01.5	O0		General-purpose output
	TOUT113	O1		GTM output
	–	O2		Reserved
	–	O3		Reserved
	MRST3	O4		QSPI3 output
	–	O5		Reserved
	DSCOUT8	O6		DSADC channel 8 output
	–	O7		Reserved
N9	P01.6	I	MP / PU1 / VEXT	General-purpose input
	TIN114			GTM input
	MTR3C			QSPI3 input
	DSDIN8A			DSADC channel 8 input A
	P01.6	O0		General-purpose output
	TOUT114	O1		GTM output
	–	O2		Reserved
	–	O3		Reserved
	MTR3	O4		QSPI3 output
	–	O5		Reserved
	–	O6		Reserved
	–	O7		Reserved

Package and Pinning Definitions TC299x Pin Definition and Functions:

Table 2-2 Port 01 Functions (cont'd)

Pin	Symbol	Ctrl	Type	Function
P10	P01.7	I	MP / PU1 / VEXT	General-purpose input
	TIN115			GTM input
	SCLK3C			QSPI3 input
	DSITR8F			DSADC channel 8 input F
	P01.7	O0		General-purpose output
	TOUT115	O1		GTM output
	–	O2		Reserved
	–	O3		Reserved
	SCLK3	O4		QSPI3 output
	–	O5		Reserved
	–	O6		Reserved
	–	O7		Reserved
	L1	P01.8		I
TIN162		GTM input		
DSDIN9A		DSADC channel 9 input A		
SENT12B		SENT input		
ARX0C		ASCLIN0 input		
RXDCAN0F		CAN node 0 input		
RXDCANr0E		CAN node 0 input (MultiCANr+)		
RXD1B1		ERAY1 input		
P01.8		O0	General-purpose output	
TOUT162		O1	GTM output	
–		O2	Reserved	
–		O3	Reserved	
–		O4	Reserved	
–	O5	Reserved		
–	O6	Reserved		
–	O7	Reserved		

Package and Pinning Definitions TC299x Pin Definition and Functions:
Table 2-2 Port 01 Functions (cont'd)

Pin	Symbol	Ctrl	Type	Function
L2	P01.9	I	LP / PU1 / VEXT	General-purpose input
	TIN160			GTM input
	DSCIN9A			DSADC channel 9 input A
	SENT11B			SENT input
	P01.9	O0		General-purpose output
	TOUT160	O1		GTM output
	—	O2		Reserved
	—	O3		Reserved
	—	O4		Reserved
	—	O5		Reserved
	DSCOUT9	O6		DSADC channel 9 output
	—	O7		Reserved
M2	P01.10	I	LP / PU1 / VEXT	General-purpose input
	TIN163			GTM input
	DSITR9F			DSADC channel 9 input F
	SENT13B			SENT input
	P01.10	O0		General-purpose output
	TOUT163	O1		GTM output
	—	O2		Reserved
	—	O3		Reserved
	—	O4		Reserved
	—	O5		Reserved
	—	O6		Reserved
	—	O7		Reserved
M1	P01.11	I	LP / PU1 / VEXT	General-purpose input
	TIN165			GTM input
	DSITR9E			DSADC channel 9 input E
	SENT14B			SENT input
	P01.11	O0		General-purpose output
	TOUT165	O1		GTM output
	—	O2		Reserved
	—	O3		Reserved
	—	O4		Reserved
	—	O5		Reserved
	—	O6		Reserved
	—	O7		Reserved

Package and Pinning Definitions TC299x Pin Definition and Functions:

Table 2-2 Port 01 Functions (cont'd)

Pin	Symbol	Ctrl	Type	Function
N2	P01.12	I	MP+ / PU1 / VEXT	General-purpose input
	TIN158			GTM input
	P01.12	O0		General-purpose output
	TOUT158	O1		GTM output
	—	O2		Reserved
	—	O3		Reserved
	—	O4		Reserved
	—	O5		Reserved
	TXD1A	O6		ERAY1 output
	—	O7		Reserved
N1	P01.13	I	MP+ / PU1 / VEXT	General-purpose input
	TIN161			GTM input
	P01.13	O0		General-purpose output
	TOUT161	O1		GTM output
	ATX0	O2		ASCLIN0 output
	—	O3		Reserved
	TXDCAN0	O4		CAN node 0 output
	TXDCANr0	O5		CAN node 0 output (MultiCANr+)
	TXD1B	O6		ERAY1 output
	—	O7		Reserved
P2	P01.14	I	MP+ / PU1 / VEXT	General-purpose input
	TIN164			GTM input
	P01.14	O0		General-purpose output
	TOUT164	O1		GTM output
	—	O2		Reserved
	—	O3		Reserved
	—	O4		Reserved
	—	O5		Reserved
	TXEN1A	O6		ERAY1 output
	—	O7		Reserved

Package and Pinning Definitions TC299x Pin Definition and Functions:

Table 2-2 Port 01 Functions (cont'd)

Pin	Symbol	Ctrl	Type	Function
P1	P01.15	I	LP / PU1 / VEXT	General-purpose input
	TIN157			GTM input
	DSDIN7A			DSADC channel 7 input A
	P01.15	O0		General-purpose output
	TOUT157	O1		GTM output
	—	O2		Reserved
	—	O3		Reserved
	—	O4		Reserved
	—	O5		Reserved
	—	O6		Reserved
	—	O7		Reserved

Table 2-3 Port 02 Functions

Pin	Symbol	Ctrl	Type	Function
G6	P02.0	I	MP+ / PU1 / VEXT	General-purpose input
	TIN0			GTM input
	REQ6			SCU input
	ARX2G			ASCLIN2 input
	CC60INA			CCU60 input
	CC60INB			CCU61 input
	CIFD0			CIF input
	P02.0			O0
	TOUT0	O1		GTM output
	ATX2	O2		ASCLIN2 output
	SLSO31	O3		QSPI3 output
	DSCGPWMN	O4		DSADC output
	TXDCAN0	O5		CAN node 0 output
	TXD0A	O6		ERAY0 output
	CC60	O7		CCU60 output

Package and Pinning Definitions TC299x Pin Definition and Functions:

Table 2-3 Port 02 Functions (cont'd)

Pin	Symbol	Ctrl	Type	Function
H7	P02.1	I	LP / PU1 / VEXT	General-purpose input
	TIN1			GTM input
	REQ14			SCU input
	ARX2B			ASCLIN2 input
	RXDCAN0A			CAN node 0 input
	RXD0A2			ERAY0 input
	CIFD1			CIF input
	P02.1	O0		General-purpose output
	TOUT1	O1		GTM output
	SLSO47	O2		QSPI4 output
	SLSO32	O3		QSPI3 output
	DSCGPWMP	O4		DSADC output
	–	O5		Reserved
	–	O6		Reserved
	COU60	O7		CCU60 output
H6	P02.2	I	MP+ / PU1 / VEXT	General-purpose input
	TIN2			GTM input
	CC61INA			CCU60 input
	CC61INB			CCU61 input
	CIFD2			CIF input
	P02.2	O0		General-purpose output
	TOUT2	O1		GTM output
	ATX1	O2		ASCLIN1 output
	SLSO33	O3		QSPI3 output
	PSITX0	O4		PSI5 output
	TXDCAN2	O5		CAN node 2 output
	TXD0B	O6		ERAY0 output
	CC61	O7		CCU60 output

Package and Pinning Definitions TC299x Pin Definition and Functions:

Table 2-3 Port 02 Functions (cont'd)

Pin	Symbol	Ctrl	Type	Function
J7	P02.3	I	LP / PU1 / VEXT	General-purpose input
	TIN3			GTM input
	ARX1G			ASCLIN1 input
	RXDCAN2B			CAN node 2 input
	RXD0B2			ERAY0 input
	PSIRX0B			PSI5 input
	DSCIN5B			DSADC channel 5 input B
	SDI11			MSC1 input
	CIFD3			CIF input
	P02.3	O0		General-purpose output
	TOUT3	O1		GTM output
	ASLSO2	O2		ASCLIN2 output
	SLSO34	O3		QSPI3 output
	DSCOUT5	O4		DSADC channel 5 output
	–	O5		Reserved
	–	O6		Reserved
	COUT61	O7		CCU60 output
J6	P02.4	I	MP+ / PU1 / VEXT	General-purpose input
	TIN4			GTM input
	SLSI3A			QSPI3 input
	ECTT1			TTCAN input
	RXDCAN0D			CAN node 0 input
	CC62INA			CCU60 input
	CC62INB			CCU61 input
	DSDIN5B			DSADC channel 5 input B
	SDA0A			I2C0 input
	CIFD4	CIF input		
	P02.4	O0		General-purpose output
	TOUT4	O1		GTM output
	ASCLK2	O2		ASCLIN2 output
	SLSO30	O3		QSPI3 output
	PSISCLK	O4		PSI5-S output
	SDA0	O5		I2C0 output
	TXEN0A	O6		ERAY0 output
CC62	O7	CCU60 output		

Package and Pinning Definitions TC299x Pin Definition and Functions:

Table 2-3 Port 02 Functions (cont'd)

Pin	Symbol	Ctrl	Type	Function
K7	P02.5	I	MP+ / PU1 / VEXT	General-purpose input
	TIN5			GTM input
	MRST3A			QSPI3 input
	ECTT2			TTCAN input
	PSIRX1B			PSI5 input
	PSISRXB			PSI5-S input
	SENT3C			SENT input
	DSCIN4B			DSADC channel 4 input B
	SCL0A			I2C0 input
	CIFD5			CIF input
	P02.5	O0		General-purpose output
	TOUT5	O1		GTM output
	TXDCAN0	O2		CAN node 0 output
	MRST3	O3		QSPI3 output
	DSCOUT4	O4		DSADC channel 4 output
	SCL0	O5		I2C0 output
	TXEN0B	O6		ERAY0 output
COUT62	O7	CCU60 output		
K6	P02.6	I	MP / PU1 / VEXT	General-purpose input
	TIN6			GTM input
	MTRSR3A			QSPI3 input
	SENT2C			SENT input
	CC60INC			CCU60 input
	CCPOS0A			CCU60 input
	T12HRB			CCU61 input
	T3INA			GPT120 input
	CIFD6			CIF input
	DSDIN4B			DSADC channel 4 input B
	DSITR5E	DSADC channel 5 input E		
	P02.6	O0		General-purpose output
	TOUT6	O1		GTM output
	PSISTX	O2		PSI5-S output
	MTRSR3	O3		QSPI3 output
	PSITX1	O4		PSI5 output
	VADCEMUX00	O5		VADC output
—	O6	Reserved		
CC60	O7	CCU60 output		

Package and Pinning Definitions TC299x Pin Definition and Functions:

Table 2-3 Port 02 Functions (cont'd)

Pin	Symbol	Ctrl	Type	Function
L7	P02.7	I	MP / PU1 / VEXT	General-purpose input
	TIN7			GTM input
	SCLK3A			QSPI3 input
	PSIRX2B			PSI5 input
	SENT1C			SENT input
	CC61INC			CCU60 input
	CCPOS1A			CCU60 input
	T13HRB			CCU61 input
	T3EUDA			GPT120 input
	CIFD7			CIF input
	DSCIN3B			DSADC channel 3 input B
	DSITR4E			DSADC channel 4 input E
	P02.7			O0
	TOUT7	O1		GTM output
	–	O2		Reserved
	SCLK3	O3		QSPI3 output
	DSCOUT3	O4		DSADC channel 3 output
	VADCEMUX01	O5		VADC output
	SPC1	O6		SENT output
	CC61	O7		CCU60 output

Package and Pinning Definitions TC299x Pin Definition and Functions:

Table 2-3 Port 02 Functions (cont'd)

Pin	Symbol	Ctrl	Type	Function	
L6	P02.8	I	LP / PU1 / VEXT	General-purpose input	
	TIN8			GTM input	
	SENT0C			SENT input	
	CC62INC			CCU60 input	
	CCPOS2A			CCU60 input	
	T12HRC			CCU61 input	
	T13HRC			CCU61 input	
	T4INA			GPT120 input	
	CIFD8			CIF input	
	DSDIN3B			DSADC channel 3 input B	
	DSITR3E			DSADC channel 3 input E	
	P02.8			O0	General-purpose output
	TOUT8			O1	GTM output
	SLSO35	O2	QSPI3 output		
	–	O3	Reserved		
	PSITX2	O4	PSI5 output		
	VADCEMUX02	O5	VADC output		
	ETHMDC	O6	ETH output		
	CC62	O7	CCU60 output		
K9	P02.9	I	LP / PU1 / VEXT	General-purpose input	
	TIN116			GTM input	
	P02.9	O0		General-purpose output	
	TOUT116	O1		GTM output	
	ATX2	O2		ASCLIN2 output	
	–	O3		Reserved	
	–	O4		Reserved	
	TXDCAN1	O5		CAN node 1 output	
	–	O6		Reserved	
	–	O7		Reserved	

Package and Pinning Definitions TC299x Pin Definition and Functions:

Table 2-3 Port 02 Functions (cont'd)

Pin	Symbol	Ctrl	Type	Function
L10	P02.10	I	LP / PU1 / VEXT	General-purpose input
	TIN117			GTM input
	ARX2C			ASCLIN2 input
	RXDCAN1E			CAN node 1 input
	P02.10	O0		General-purpose output
	TOUT117	O1		GTM output
	—	O2		Reserved
	—	O3		Reserved
	—	O4		Reserved
	—	O5		Reserved
	—	O6		Reserved
—	O7	Reserved		
L9	P02.11	I	LP / PU1 / VEXT	General-purpose input
	TIN118			GTM input
	P02.11	O0		General-purpose output
	TOUT118	O1		GTM output
	—	O2		Reserved
	—	O3		Reserved
	—	O4		Reserved
	—	O5		Reserved
	—	O6		Reserved
	—	O7		Reserved
F2	P02.12	I	LP / PU1 / VEXT	General-purpose input
	TIN151			GTM input
	P02.12	O0		General-purpose output
	TOUT151	O1		GTM output
	SLSO35	O2		QSPI3 output
	SLSO44	O3		QSPI4 output
	—	O4		Reserved
	—	O5		Reserved
	—	O6		Reserved
	—	O7		Reserved

Package and Pinning Definitions TC299x Pin Definition and Functions:

Table 2-3 Port 02 Functions (cont'd)

Pin	Symbol	Ctrl	Type	Function
F1	P02.13	I	LP / PU1 / VEXT	General-purpose input
	TIN153			GTM input
	P02.13	O0		General-purpose output
	TOUT153	O1		GTM output
	SLSO37	O2		QSPI3 output
	SLSO46	O3		QSPI4 output
	TXDCAN0	O4		CAN node 0 output
	TXDCANr0	O5		CAN node 0 output (MultiCANr+)
	—	O6		Reserved
	—	O7		Reserved
G2	P02.14	I	LP / PU1 / VEXT	General-purpose input
	TIN154			GTM input
	RXDCAN0H			CAN node 0 input
	RXDCANr0D			CAN node 0 input (MultiCANr+)
	P02.14	O0		General-purpose output
	TOUT154	O1		GTM output
	—	O2		Reserved
	—	O3		Reserved
	—	O4		Reserved
	—	O5		Reserved
	—	O6		Reserved
	—	O7		Reserved
G1	P02.15	I	MP+ / PU1 / VEXT	General-purpose input
	TIN152			GTM input
	P02.15	O0		General-purpose output
	TOUT152	O1		GTM output
	SLSO36	O2		QSPI3 output
	SLSO45	O3		QSPI4 output
	—	O4		Reserved
	—	O5		Reserved
	TXEN1B	O6		ERAY1 output
	—	O7		Reserved

Package and Pinning Definitions TC299x Pin Definition and Functions:

Table 2-4 Port 10 Functions

Pin	Symbol	Ctrl	Type	Function
F12	P10.0	I	LP / PU1 / VEXT	General-purpose input
	TIN102			GTM input
	T6EUDB			GPT120 input
	P10.0	O0		General-purpose output
	TOUT102	O1		GTM output
	–	O2		Reserved
	SLSO110	O3		QSPI1 output
	–	O4		Reserved
	VADCG6BFL0	O5		VADC output
	–	O6		Reserved
	–	O7		Reserved
	G12	P10.1		I
TIN103		GTM input		
MRST1A		QSPI1 input		
T5EUDB		GPT120 input		
P10.1		O0	General-purpose output	
TOUT103		O1	GTM output	
MTSR1		O2	QSPI1 output	
MRST1		O3	QSPI1 output	
EN01		O4	MSC0 output	
VADCG6BFL1		O5	VADC output	
END03		O6	MSC0 output	
–		O7	Reserved	
F10	P10.2	I	MP / PU1 / VEXT	General-purpose input
	TIN104			GTM input
	SCLK1A			QSPI1 input
	T6INB			GPT120 input
	REQ2			SCU input
	RXDCAN2E			CAN node 2 input
	SDI01			MSC0 input
	P10.2			O0
	TOUT104	O1		GTM output
	–	O2		Reserved
	SCLK1	O3		QSPI1 output
	EN00	O4		MSC0 output
	VADCG6BFL2	O5		VADC output
	END02	O6		MSC0 output
	–	O7		Reserved

Package and Pinning Definitions TC299x Pin Definition and Functions:

Table 2-4 Port 10 Functions (cont'd)

Pin	Symbol	Ctrl	Type	Function
F11	P10.3	I	MP / PU1 / VEXT	General-purpose input
	TIN105			GTM input
	MTSR1A			QSPI1 input
	REQ3			SCU input
	T5INB			GPT120 input
	P10.3			O0
	TOUT105	O1		GTM output
	VADCG6BFL3	O2		VADC output
	MTSR1	O3		QSPI1 output
	EN00	O4		MSC0 output
	END02	O5		MSC0 output
	TXDCAN2	O6		CAN node 2 output
	–	O7		Reserved
	G11	P10.4		I
TIN106		GTM input		
MTSR1C		QSPI1 input		
CCPOS0C		CCU60 input		
T3INB		GPT120 input		
P10.4		O0	General-purpose output	
TOUT106		O1	GTM output	
–		O2	Reserved	
SLSO18		O3	QSPI1 output	
MTSR1		O4	QSPI1 output	
EN00		O5	MSC0 output	
END02		O6	MSC0 output	
–		O7	Reserved	

Package and Pinning Definitions TC299x Pin Definition and Functions:

Table 2-4 Port 10 Functions (cont'd)

Pin	Symbol	Ctrl	Type	Function
G10	P10.5	I	LP / PU1 / VEXT	General-purpose input
	TIN107			GTM input
	HWCFG4			SCU input
	RXDCANr0A			CAN node 0 input (MultiCANr+)
	INJ01			MSC0 input
	P10.5	O0		General-purpose output
	TOUT107	O1		GTM output
	ATX2	O2		ASCLIN2 output
	SLSO38	O3		QSPI3 output
	SLSO19	O4		QSPI1 output
	T6OUT	O5		GPT120 output
	ASLSO2	O6		ASCLIN2 output
	PSITX3	O7		PSI5 output
	F9	P10.6		I
TIN108		GTM input		
ARX2D		ASCLIN2 input		
MTSR3B		QSPI3 input		
PSIRX3C		PSI5 input		
HWCFG5		SCU input		
P10.6		O0	General-purpose output	
TOUT108		O1	GTM output	
ASCLK2		O2	ASCLIN2 output	
MTSR3		O3	QSPI3 output	
T3OUT		O4	GPT120 output	
TXDCANr0		O5	CAN node 0 output (MultiCANr+)	
MRST1		O6	QSPI1 output	
VADCG7BFL0		O7	VADC output	

Package and Pinning Definitions TC299x Pin Definition and Functions:
Table 2-4 Port 10 Functions (cont'd)

Pin	Symbol	Ctrl	Type	Function
F8	P10.7	I	LP / PU1 / VEXT	General-purpose input
	TIN109			GTM input
	ACTS2A			ASCLIN2 input
	MRST3B			QSPI3 input
	REQ4			SCU input
	CCPOS1C			CCU60 input
	T3EUDB			GPT120 input
	P10.7			O0
	TOUT109	O1		GTM output
	–	O2		Reserved
	MRST3	O3		QSPI3 output
	VADCG7BFL1	O4		VADC output
	TXDCANr0	O5		CAN node 0 output (MultiCANr+)
	–	O6		Reserved
	–	O7		Reserved
	G9	P10.8		I
TIN110		GTM input		
SCLK3B		QSPI3 input		
REQ5		SCU input		
CCPOS2C		CCU60 input		
T4INB		GPT120 input		
RXDCANr0B		CAN node 0 input (MultiCANr+)		
P10.8		O0	General-purpose output	
TOUT110		O1	GTM output	
ARTS2		O2	ASCLIN2 output	
SCLK3		O3	QSPI3 output	
–		O4	Reserved	
–		O5	Reserved	
–		O6	Reserved	
–		O7	Reserved	

Package and Pinning Definitions TC299x Pin Definition and Functions:

Table 2-4 Port 10 Functions (cont'd)

Pin	Symbol	Ctrl	Type	Function
B8	P10.9	I	LP / PU1 / VEXT	General-purpose input
	TIN265			GTM input
	SENT10C			SENT input
	P10.9	O0		General-purpose output
	TOUT265	O1		GTM output
	—	O2		Reserved
	—	O3		Reserved
	—	O4		Reserved
	—	O5		Reserved
	—	O6		Reserved
	—	O7		Reserved
B7	P10.10	I	LP / PU1 / VEXT	General-purpose input
	TIN266			GTM input
	SENT11C			SENT input
	P10.10	O0		General-purpose output
	TOUT266	O1		GTM output
	—	O2		Reserved
	—	O3		Reserved
	—	O4		Reserved
	—	O5		Reserved
	—	O6		Reserved
	—	O7		Reserved
A7	P10.11	I	LP / PU1 / VEXT	General-purpose input
	TIN269			GTM input
	SENT14C			SENT input
	P10.11	O0		General-purpose output
	TOUT269	O1		GTM output
	—	O2		Reserved
	—	O3		Reserved
	—	O4		Reserved
	—	O5		Reserved
	—	O6		Reserved
	—	O7		Reserved

Package and Pinning Definitions TC299x Pin Definition and Functions:

Table 2-4 Port 10 Functions (cont'd)

Pin	Symbol	Ctrl	Type	Function
A6	P10.13	I	LP / PU1 / VEXT	General-purpose input
	TIN268			GTM input
	SENT13C			SENT input
	P10.13	O0		General-purpose output
	TOUT268	O1		GTM output
	—	O2		Reserved
	—	O3		Reserved
	—	O4		Reserved
	—	O5		Reserved
	—	O6		Reserved
—	O7	Reserved		
B5	P10.14	I	LP / PU1 / VEXT	General-purpose input
	TIN267			GTM input
	SENT12C			SENT input
	P10.14	O0		General-purpose output
	TOUT267	O1		GTM output
	—	O2		Reserved
	—	O3		Reserved
	—	O4		Reserved
	—	O5		Reserved
	—	O6		Reserved
—	O7	Reserved		
A5	P10.15	I	LP / PU1 / VEXT	General-purpose input
	TIN270			GTM input
	P10.15			O0
	TOUT270	O1		GTM output
	—	O2		Reserved
	—	O3		Reserved
	—	O4		Reserved
	—	O5		Reserved
	—	O6		Reserved
	—	O7		Reserved

Package and Pinning Definitions TC299x Pin Definition and Functions:

Table 2-5 Port 11 Functions

Pin	Symbol	Ctrl	Type	Function
K15	P11.0	I	MP+ / PU1 / VFLEX	General-purpose input
	TIN119			GTM input
	ARX3B			ASCLIN3 input
	P11.0	O0		General-purpose output
	TOUT119	O1		GTM output
	ATX3	O2		ASCLIN3 output
	–	O3		Reserved
	–	O4		Reserved
	–	O5		Reserved
	ETHTXD3	O6		ETH output
	–	O7		Reserved
K14	P11.1	I	MP+ / PU1 / VFLEX	General-purpose input
	TIN120			GTM input
	P11.1			O0
	TOUT120	O1		GTM output
	ASCLK3	O2		ASCLIN3 output
	ATX3	O3		ASCLIN3 output
	–	O4		Reserved
	–	O5		Reserved
	ETHTXD2	O6		ETH output
	–	O7		Reserved
	F15	P11.2		I
TIN95		GTM input		
P11.2		O0	General-purpose output	
TOUT95		O1	GTM output	
END03		O2	MSC0 output	
SLSO05		O3	QSPI0 output	
SLSO15		O4	QSPI1 output	
EN01		O5	MSC0 output	
ETHTXD1		O6	ETH output	
COU63		O7	CCU60 output	

Package and Pinning Definitions TC299x Pin Definition and Functions:

Table 2-5 Port 11 Functions (cont'd)

Pin	Symbol	Ctrl	Type	Function
G15	P11.3	I	MPR / PU1 / VFLEX	General-purpose input
	TIN96			GTM input
	MRST1B			QSPI1 input
	SDI03			MSC0 input
	P11.3	O0		General-purpose output
	TOUT96	O1		GTM output
	–	O2		Reserved
	MRST1	O3		QSPI1 output
	TXD0A	O4		ERAY0 output
	–	O5		Reserved
	ETHTXD0	O6		ETH output
	COUT62	O7		CCU60 output
J15	P11.4	I	MP+ / PU1 / VFLEX	General-purpose input
	TIN121			GTM input
	ETHRXCLKB			ETH input
	P11.4			General-purpose output
	TOUT121	O1		GTM output
	ASCLK3	O2		ASCLIN3 output
	–	O3		Reserved
	–	O4		Reserved
	–	O5		Reserved
	ETHTXER	O6		ETH output
	–	O7		Reserved
	J13	P11.5		I
TIN122		GTM input		
ETHTXCLKA		ETH input		
P11.5		General-purpose output		
TOUT122		O1	GTM output	
–		O2	Reserved	
–		O3	Reserved	
–		O4	Reserved	
–		O5	Reserved	
–		O6	Reserved	
–		O7	Reserved	

Package and Pinning Definitions TC299x Pin Definition and Functions:

Table 2-5 Port 11 Functions (cont'd)

Pin	Symbol	Ctrl	Type	Function
J14	P11.6	I	MPR / PU1 / VFLEX	General-purpose input
	TIN97			GTM input
	SCLK1B			QSPI1 input
	P11.6	O0		General-purpose output
	TOUT97	O1		GTM output
	TXEN0B	O2		ERAY0 output
	SCLK1	O3		QSPI1 output
	TXEN0A	O4		ERAY0 output
	FCLP0	O5		MSC0 output
	ETHTXEN	O6		ETH output
	COU61	O7		CCU60 output
K13	P11.7	I	LP / PU1 / VFLEX	General-purpose input
	TIN123			GTM input
	ETHRXD3			ETH input
	P11.7	O0		General-purpose output
	TOUT123	O1		GTM output
	–	O2		Reserved
	–	O3		Reserved
	–	O4		Reserved
	–	O5		Reserved
	–	O6		Reserved
	–	O7		Reserved
K12	P11.8	I	LP / PU1 / VFLEX	General-purpose input
	TIN124			GTM input
	ETHRXD2			ETH input
	P11.8	O0		General-purpose output
	TOUT124	O1		GTM output
	–	O2		Reserved
	–	O3		Reserved
	–	O4		Reserved
	–	O5		Reserved
	–	O6		Reserved
	–	O7		Reserved

Package and Pinning Definitions TC299x Pin Definition and Functions:

Table 2-5 Port 11 Functions (cont'd)

Pin	Symbol	Ctrl	Type	Function
F14	P11.9	I	MP+ / PU1 / VFLEX	General-purpose input
	TIN98			GTM input
	MTSR1B			QSPI1 input
	RXD0A1			ERAY0 input
	ETHRXD1			ETH input
	P11.9			O0
	TOUT98	O1		GTM output
	–	O2		Reserved
	MTSR1	O3		QSPI1 output
	–	O4		Reserved
	SOP0	O5		MSC0 output
	–	O6		Reserved
	COUT60	O7		CCU60 output
	G14	P11.10		I
TIN99		GTM input		
REQ12		SCU input		
ARX1E		ASCLIN1 input		
SLS1A		QSPI1 input		
RXDCAN3D		CAN node 3 input		
RXD0B1		ERAY0 input		
ETHRXD0		ETH input		
SDI00		MSC0 input		
P11.10		O0	General-purpose output	
TOUT99		O1	GTM output	
–		O2	Reserved	
SLSO03		O3	QSPI0 output	
SLSO13		O4	QSPI1 output	
–		O5	Reserved	
–		O6	Reserved	
CC62		O7	CCU60 output	

Package and Pinning Definitions TC299x Pin Definition and Functions:

Table 2-5 Port 11 Functions (cont'd)

Pin	Symbol	Ctrl	Type	Function
F13	P11.11	I	MP+ / PU1 / VFLEX	General-purpose input
	TIN100			GTM input
	ETHCRSDVA			ETH input
	ETHRXDVA			ETH input
	ETHCRSB			ETH input
	P11.11	O0		General-purpose output
	TOUT100	O1		GTM output
	END02	O2		MSC0 output
	SLSO04	O3		QSPI0 output
	SLSO14	O4		QSPI1 output
	EN00	O5		MSC0 output
	TXEN0B	O6		ERAY0 output
	CC61	O7		CCU60 output
G13	P11.12	I	MPR / PU1 / VFLEX	General-purpose input
	TIN101			GTM input
	ETHREFCLK			ETH input
	ETHTXCLKB			ETH input (Not for productive purposes)
	ETHRXCLKA			ETH input (Not for productive purposes)
	P11.12	O0		General-purpose output
	TOUT101	O1		GTM output
	ATX1	O2		ASCLIN1 output
	GTMCLK2	O3		GTM output
	TXD0B	O4		ERAY0 output
	TXDCAN3	O5		CAN node 3 output
	EXTCLK1	O6		SCU output
	CC60	O7		CCU60 output

Package and Pinning Definitions TC299x Pin Definition and Functions:

Table 2-5 Port 11 Functions (cont'd)

Pin	Symbol	Ctrl	Type	Function
K11	P11.13	I	LP / PU1 / VFLEX	General-purpose input
	TIN125			GTM input
	ETHRXERA			ETH input
	SDA1A			I2C1 input
	P11.13	O0		General-purpose output
	TOUT125	O1		GTM output
	–	O2		Reserved
	–	O3		Reserved
	–	O4		Reserved
	–	O5		Reserved
	SDA1	O6		I2C1 output
	–	O7		Reserved
J12	P11.14	I	LP / PU1 / VFLEX	General-purpose input
	TIN126			GTM input
	ETHCRSDVB			ETH input
	ETHRXDVB			ETH input
	ETHCRSA	ETH input		
	SCL1A	I2C1 input		
	P11.14	O0		General-purpose output
	TOUT126	O1		GTM output
	–	O2		Reserved
	–	O3		Reserved
	–	O4		Reserved
	–	O5		Reserved
SCL1	O6	I2C1 output		
–	O7	Reserved		
J11	P11.15	I	LP / PU1 / VFLEX	General-purpose input
	TIN127			GTM input
	ETHCOL			ETH input
	P11.15			O0
	TOUT127	O1		GTM output
	–	O2		Reserved
	–	O3		Reserved
	–	O4		Reserved
	–	O5		Reserved
	–	O6		Reserved
	–	O7		Reserved

Package and Pinning Definitions TC299x Pin Definition and Functions:

Table 2-6 Port 12 Functions

Pin	Symbol	Ctrl	Type	Function
K17	P12.0	I	LP / PU1 / VFLEX	General-purpose input
	TIN128			GTM input
	ETHRXCLKC			ETH input
	RXDCAN0C			CAN node 0 input
	P12.0	O0		General-purpose output
	TOUT128	O1		GTM output
	—	O2		Reserved
	—	O3		Reserved
	—	O4		Reserved
	—	O5		Reserved
	ETHMDC	O6		ETH output
	—	O7		Reserved
K16	P12.1	I	LP / PU1 / VFLEX	General-purpose input
	TIN129			GTM input
	P12.1	O0		General-purpose output
	TOUT129	O1		GTM output
	ASLSO3	O2		ASCLIN3 output
	—	O3		Reserved
	—	O4		Reserved
	TXDCAN0	O5		CAN node 0 output
	—	O6		Reserved
	—	O7		Reserved
	ETHMDIOC	HWOUT		ETH input/output

Table 2-7 Port 13 Functions

Pin	Symbol	Ctrl	Type	Function
G17	P13.0	I	LVDSM_N / PU1 / VEXT	General-purpose input
	TIN91			GTM input
	P13.0	O0		General-purpose output
	TOUT91	O1		GTM output
	END03	O2		MSC0 output
	SCLK2N	O3		QSPI2 output (LVDS)
	EN01	O4		MSC0 output
	FCLN0	O5		MSC0 output (LVDS)
	FCLND0	O6		MSC0 output (LVDS)
	—	O7		Reserved

Package and Pinning Definitions TC299x Pin Definition and Functions:

Table 2-7 Port 13 Functions (cont'd)

Pin	Symbol	Ctrl	Type	Function
F17	P13.1	I	LVDSM_P / PU1 / VEXT	General-purpose input
	TIN92			GTM input
	SCL0B			I2C0 input
	P13.1	O0		General-purpose output
	TOUT92	O1		GTM output
	–	O2		Reserved
	SCLK2P	O3		QSPI2 output (LVDS)
	–	O4		Reserved
	FCLP0	O5		MSC0 output (LVDS)
	SCL0	O6		I2C0 output
	–	O7		Reserved
	G16	P13.2		I
TIN93		GTM input		
CAPINA		GPT120 input		
SDA0B		I2C0 input		
P13.2		O0	General-purpose output	
TOUT93		O1	GTM output	
–		O2	Reserved	
MTSR2N		O3	QSPI2 output (LVDS)	
FCLP0		O4	MSC0 output	
SON0		O5	MSC0 output (LVDS)	
SDA0		O6	I2C0 output	
SOND0		O7	MSC0 output (LVDS)	
F16	P13.3	I	LVDSM_P / PU1 / VEXT	General-purpose input
	TIN94			GTM input
	P13.3	O0		General-purpose output
	TOUT94	O1		GTM output
	–	O2		Reserved
	MTSR2P	O3		QSPI2 output (LVDS)
	–	O4		Reserved
	SOP0	O5		MSC0 output (LVDS)
	–	O6		Reserved
	–	O7		Reserved

Package and Pinning Definitions TC299x Pin Definition and Functions:

Table 2-7 Port 13 Functions (cont'd)

Pin	Symbol	Ctrl	Type	Function
B16	P13.4	I	LVDSM_N / PU1 / VEXT	General-purpose input
	TIN253			GTM input
	PSIRX4A			PSI5 input
	P13.4	O0		General-purpose output
	TOUT253	O1		GTM output
	END22	O2		MSC2 output
	–	O3		Reserved
	EN20	O4		MSC2 output
	FCLN2	O5		MSC2 output (LVDS)
	FCLND2	O6		MSC2 output (LVDS)
	–	O7		Reserved
A16	P13.5	I	LVDSM_P / PU1 / VEXT	General-purpose input
	TIN254			GTM input
	P13.5			O0
	TOUT254	O1		GTM output
	–	O2		Reserved
	–	O3		Reserved
	–	O4		Reserved
	FCLP2	O5		MSC2 output (LVDS)
	–	O6		Reserved
	–	O7		Reserved
	B15	P13.6		I
TIN255		GTM input		
P13.6		O0	General-purpose output	
TOUT255		O1	GTM output	
–		O2	Reserved	
–		O3	Reserved	
–		O4	Reserved	
SON2		O5	MSC2 output (LVDS)	
SOND2		O6	MSC2 output (LVDS)	
–		O7	Reserved	

Package and Pinning Definitions TC299x Pin Definition and Functions:

Table 2-7 Port 13 Functions (cont'd)

Pin	Symbol	Ctrl	Type	Function
A15	P13.7	I	LVDSM_P / PU1 / VEXT	General-purpose input
	TIN256			GTM input
	P13.7			General-purpose output
	TOUT256	O1		GTM output
	—	O2		Reserved
	—	O3		Reserved
	—	O4		Reserved
	SOP2	O5		MSC2 output (LVDS)
	—	O6		Reserved
	—	O7		Reserved
A14	P13.9	I	MP / PU1 / VEXT	General-purpose input
	TIN248			GTM input
	SCL1B			I2C1 input
	P13.9	O0		General-purpose output
	TOUT248	O1		GTM output
	ATX3	O2		ASCLIN3 output
	SLSO55	O3		QSPI5 output
	—	O4		Reserved
	TXDCANr1	O5		CAN node 1 output (MultiCANr+)
	SCL1	O6		I2C1 output
	—	O7		Reserved
B13	P13.10	I	LP / PU1 / VEXT	General-purpose input
	TIN251			GTM input
	PSIRX3A			PSI5 input
	P13.10	O0		General-purpose output
	TOUT251	O1		GTM output
	ATX0	O2		ASCLIN0 output
	—	O3		Reserved
	—	O4		Reserved
	—	O5		Reserved
	—	O6		Reserved
	—	O7		Reserved

Package and Pinning Definitions TC299x Pin Definition and Functions:

Table 2-7 Port 13 Functions (cont'd)

Pin	Symbol	Ctrl	Type	Function
A13	P13.11	I	LP / PU1 / VEXT	General-purpose input
	TIN250			GTM input
	ARX0E			ASCLIN0 input
	P13.11	O0		General-purpose output
	TOUT250	O1		GTM output
	—	O2		Reserved
	—	O3		Reserved
	—	O4		Reserved
	PSITX3	O5		PSI5 output
	—	O6		Reserved
	—	O7		Reserved
B12	P13.12	I	LP / PU1 / VEXT	General-purpose input
	TIN249			GTM input
	ARX3H			ASCLIN3 input
	RXDCANr1B			CAN node 1 input (MultiCANr+)
	SDA1B			I2C1 input
	P13.12	O0		General-purpose output
	TOUT249	O1		GTM output
	—	O2		Reserved
	—	O3		Reserved
	—	O4		Reserved
	—	O5		Reserved
SDA1	O6	I2C1 output		
—	O7	Reserved		
A12	P13.13	I	LP / PU1 / VEXT	General-purpose input
	TIN262			GTM input
	PSIRX3B			PSI5 input
	INJ20			MSC2 input
	—	—		—
	P13.13	O0		General-purpose output
	TOUT262	O1		GTM output
	—	O2		Reserved
	—	O3		Reserved
	—	O4		Reserved
	—	O5		Reserved
—	O6	Reserved		
—	O7	Reserved		

Package and Pinning Definitions TC299x Pin Definition and Functions:

Table 2-7 Port 13 Functions (cont'd)

Pin	Symbol	Ctrl	Type	Function
B11	P13.14	I	LP / PU1 / VEXT	General-purpose input
	TIN252			GTM input
	P13.14	O0		General-purpose output
	TOUT252	O1		GTM output
	—	O2		Reserved
	SLSO54	O3		QSPI5 output
	—	O4		Reserved
	—	O5		Reserved
	—	O6		Reserved
	—	O7		Reserved
A11	P13.15	I	LP / PU1 / VEXT	General-purpose input
	TIN264			GTM input
	P13.15	O0		General-purpose output
	TOUT264	O1		GTM output
	—	O2		Reserved
	—	O3		Reserved
	PSITX3	O4		PSI5 output
	—	O5		Reserved
	—	O6		Reserved
	—	O7		Reserved

Table 2-8 Port 14 Functions

Pin	Symbol	Ctrl	Type	Function
G21	P14.0	I	MP+ / PU1 / VEXT	General-purpose input
	TIN80			GTM input
	SENT12D			SENT input
	P14.0	O0		General-purpose output
	TOUT80	O1		GTM output
	ATX0	O2		ASCLIN0 output Recommended as Boot loader pin
	TXD0A	O3		ERAY0 output
	TXD0B	O4		ERAY0 output
	TXDCAN1	O5		CAN node 1 output Used for single pin DAP (SPD) function
	ASCLK0	O6		ASCLIN0 output
	COU62	O7		CCU60 output

Package and Pinning Definitions TC299x Pin Definition and Functions:

Table 2-8 Port 14 Functions (cont'd)

Pin	Symbol	Ctrl	Type	Function
F20	P14.1	I	MP / PU1 / VEXT	General-purpose input
	TIN81			GTM input
	REQ15			SCU input
	SENT13D			SENT input
	ARX0A			ASCLIN0 input Recommended as Boot loader pin
	RXDCAN1B			CAN node 1 input Used for single pin DAP (SPD) function
	RXD0A3			ERAY0 input
	RXD0B3			ERAY0 input
	EVRWUPA			SCU input
	P14.1			O0
	TOUT81	O1		GTM output
	ATX0	O2		ASCLIN0 output Recommended as Boot loader pin.
	–	O3		Reserved
	–	O4		Reserved
	–	O5		Reserved
	–	O6		Reserved
	COUT63	O7		CCU60 output
K18	P14.2	I	LP / PU1 / VEXT	General-purpose input
	TIN82			GTM input
	HWCFG2 EVR13			SCU input Latched at cold power on reset to decide EVR13 activation.
	P14.2	O0		General-purpose output
	TOUT82	O1		GTM output
	ATX2	O2		ASCLIN2 output
	SLSO21	O3		QSPI2 output
	–	O4		Reserved
	–	O5		Reserved
	ASCLK2	O6		ASCLIN2 output
	–	O7		Reserved

Package and Pinning Definitions TC299x Pin Definition and Functions:

Table 2-8 Port 14 Functions (cont'd)

Pin	Symbol	Ctrl	Type	Function
G19	P14.3	I	LP / PU1 / VEXT	General-purpose input
	TIN83			GTM input
	ARX2A			ASCLIN2 input
	REQ10			SCU input
	HWCFG3_BMI			SCU input
	SDI02			MSC0 input
	P14.3			O0
	TOUT83	O1		GTM output
	ATX2	O2		ASCLIN2 output
	SLSO23	O3		QSPI2 output
	ASLSO1	O4		ASCLIN1 output
	ASLSO3	O5		ASCLIN3 output
	-	O6		Reserved
	-	O7		Reserved
G20	P14.4	I	LP / PU1 / VEXT	General-purpose input
	TIN84			GTM input
	HWCFG6			SCU input Latched at cold power on reset to decide default pad reset state (PU or HighZ).
	P14.4	O0		General-purpose output
	TOUT84	O1		GTM output
	-	O2		Reserved
	-	O3		Reserved
	-	O4		Reserved
	-	O5		Reserved
	-	O6		Reserved
-	O7	Reserved		

Package and Pinning Definitions TC299x Pin Definition and Functions:

Table 2-8 Port 14 Functions (cont'd)

Pin	Symbol	Ctrl	Type	Function
F19	P14.5	I	MP+ / PU1 / VEXT	General-purpose input
	TIN85			GTM input
	HWCFG1 EVR33			SCU input Latched at cold power on reset to decide EVR33 activation.
	P14.5	O0		General-purpose output
	TOUT85	O1		GTM output
	—	O2		Reserved
	—	O3		Reserved
	—	O4		Reserved
	—	O5		Reserved
	TXD0B	O6		ERAY0 output
TXD1B	O7	ERAY1 output		
G18	P14.6	I	MP+ / PU1 / VEXT	General-purpose input
	TIN86			GTM input
	HWCFG0 DCLDO			SCU input If EVR13 active, latched at cold power on reset to decide between LDO and SMPS mode.
	P14.6	O0		General-purpose output
	TOUT86	O1		GTM output
	—	O2		Reserved
	SLSO22	O3		QSPI2 output
	—	O4		Reserved
	—	O5		Reserved
	TXEN0B	O6		ERAY0 output
TXEN1B	O7	ERAY1 output		
J18	P14.7	I	LP / PU1 / VEXT	General-purpose input
	TIN87			GTM input
	RXD0B0			ERAY0 input
	RXD1B0			ERAY1 input
	P14.7	O0		General-purpose output
	TOUT87	O1		GTM output
	ARTS0	O2		ASCLIN0 output
	SLSO24	O3		QSPI2 output
	—	O4		Reserved
	—	O5		Reserved
—	O6	Reserved		
—	O7	Reserved		

Package and Pinning Definitions TC299x Pin Definition and Functions:

Table 2-8 Port 14 Functions (cont'd)

Pin	Symbol	Ctrl	Type	Function
F18	P14.8	I	LP / PU1 / VEXT	General-purpose input
	TIN88			GTM input
	ARX1D			ASCLIN1 input
	RXDCAN2D			CAN node 2 input
	RXD0A0			ERAY0 input
	RXD1A0			ERAY1 input
	P14.8			O0
	TOUT88	O1		GTM output
	—	O2		Reserved
	—	O3		Reserved
	—	O4		Reserved
	—	O5		Reserved
	—	O6		Reserved
	—	O7		Reserved
J17	P14.9	I	MP+ / PU1 / VEXT	General-purpose input
	TIN89			GTM input
	ACTS0A			ASCLIN0 input
	P14.9	O0		General-purpose output
	TOUT89	O1		GTM output
	END03	O2		MSC0 output
	EN01	O3		MSC0 output
	—	O4		Reserved
	$\overline{\text{TXEN0B}}$	O5		ERAY0 output
	$\overline{\text{TXEN0A}}$	O6		ERAY0 output
	$\overline{\text{TXEN1A}}$	O7		ERAY1 output
J16	P14.10	I	MP+ / PU1 / VEXT	General-purpose input
	TIN90			GTM input
	P14.10	O0		General-purpose output
	TOUT90	O1		GTM output
	END02	O2		MSC0 output
	EN00	O3		MSC0 output
	ATX1	O4		ASCLIN1 output
	TXDCAN2	O5		CAN node 2 output
	TXD0A	O6		ERAY0 output
	TXD1A	O7		ERAY1 output

Package and Pinning Definitions TC299x Pin Definition and Functions:

Table 2-8 Port 14 Functions (cont'd)

Pin	Symbol	Ctrl	Type	Function
A20	P14.11	I	LP / PU1 / VEXT	General-purpose input
	TIN258			GTM input
	P14.11	O0		General-purpose output
	TOUT258	O1		GTM output
	END20	O2		MSC2 output
	PSITX4	O3		PSI5 output
	EN22	O4		MSC2 output
	SOP2	O5		MSC2 output
	–	O6		Reserved
	–	O7		Reserved
B19	P14.12	I	LP / PU1 / VEXT	General-purpose input
	TIN261			GTM input
	SDI20			MSC2 input
	P14.12	O0		General-purpose output
	TOUT261	O1		GTM output
	–	O2		Reserved
	–	O3		Reserved
	–	O4		Reserved
	–	O5		Reserved
	–	O6		Reserved
–	O7	Reserved		
A19	P14.13	I	MP+ / PU1 / VEXT	General-purpose input
	TIN260			GTM input
	P14.13	O0		General-purpose output
	TOUT260	O1		GTM output
	END23	O2		MSC2 output
	–	O3		Reserved
	EN21	O4		MSC2 output
	–	O5		Reserved
	–	O6		Reserved
	–	O7		Reserved

Package and Pinning Definitions TC299x Pin Definition and Functions:

Table 2-8 Port 14 Functions (cont'd)

Pin	Symbol	Ctrl	Type	Function
B18	P14.14	I	MP+ / PU1 / VEXT	General-purpose input
	TIN259			GTM input
	P14.14	O0		General-purpose output
	TOUT259	O1		GTM output
	END22	O2		MSC2 output
	—	O3		Reserved
	EN20	O4		MSC2 output
	—	O5		Reserved
	—	O6		Reserved
	—	O7		Reserved
A18	P14.15	I	LP / PU1 / VEXT	General-purpose input
	TIN263			GTM input
	INJ21			MSC2 output
	P14.15	O0		General-purpose output
	TOUT263	O1		GTM output
	ATX1	O2		ASCLIN1 output
	—	O3		Reserved
	—	O4		Reserved
	—	O5		Reserved
	—	O6		Reserved
—	O7	Reserved		

Table 2-9 Port 15 Functions

Pin	Symbol	Ctrl	Type	Function
G25	P15.0	I	LP / PU1 / VEXT	General-purpose input
	TIN71			GTM input
	P15.0	O0		General-purpose output
	TOUT71	O1		GTM output
	ATX1	O2		ASCLIN1 output
	SLSO013	O3		QSPI0 output
	—	O4		Reserved
	TXDCAN2	O5		CAN node 2 output
	ASCLK1	O6		ASCLIN1 output
	—	O7		Reserved

Package and Pinning Definitions TC299x Pin Definition and Functions:

Table 2-9 Port 15 Functions (cont'd)

Pin	Symbol	Ctrl	Type	Function
F23	P15.1	I	LP / PU1 / VEXT	General-purpose input
	TIN72			GTM input
	REQ16			SCU input
	ARX1A			ASCLIN1 input
	RXDCAN2A			CAN node 2 input
	SLSI2B			QSPI2 input
	EVRWUPB			SCU input
	P15.1	O0		General-purpose output
	TOUT72	O1		GTM output
	ATX1	O2		ASCLIN1 output
	SLSO25	O3		QSPI2 output
	—	O4		Reserved
	—	O5		Reserved
	—	O6		Reserved
—	O7	Reserved		
H24	P15.2	I	MP / PU1 / VEXT	General-purpose input
	TIN73			GTM input
	SLSI2A			QSPI2 input
	MRST2E			QSPI2 input
	SENT10D			SENT input
	HSIC2INA			QSPI2 input
	P15.2			O0
	TOUT73	O1		GTM output
	ATX0	O2		ASCLIN0 output
	SLSO20	O3		QSPI2 output
	—	O4		Reserved
	TXDCAN1	O5		CAN node 1 output
	ASCLK0	O6		ASCLIN0 output
	—	O7		Reserved

Package and Pinning Definitions TC299x Pin Definition and Functions:

Table 2-9 Port 15 Functions (cont'd)

Pin	Symbol	Ctrl	Type	Function
G22	P15.3	I	MP / PU1 / VEXT	General-purpose input
	TIN74			GTM input
	ARX0B			ASCLIN0 input
	SCLK2A			QSPI2 input
	RXDCAN1A			CAN node 1 input
	HSIC2INB			QSPI2 input
	P15.3	O0		General-purpose output
	TOUT74	O1		GTM output
	ATX0	O2		ASCLIN0 output
	SCLK2	O3		QSPI2 output
	END03	O4		MSC0 output
	EN01	O5		MSC0 output
	—	O6		Reserved
	—	O7		Reserved
F22	P15.4	I	MP / PU1 / VEXT	General-purpose input
	TIN75			GTM input
	MRST2A			QSPI2 input
	REQ0			SCU input
	SCL0C			I2C0 input
	SENT11D			SENT input
	P15.4	O0		General-purpose output
	TOUT75	O1		GTM output
	ATX1	O2		ASCLIN1 output
	MRST2	O3		QSPI2 output
	—	O4		Reserved
	—	O5		Reserved
	SCL0	O6		I2C0 output
	CC62	O7		CCU60 output

Package and Pinning Definitions TC299x Pin Definition and Functions:

Table 2-9 Port 15 Functions (cont'd)

Pin	Symbol	Ctrl	Type	Function
K19	P15.5	I	MP / PU1 / VEXT	General-purpose input
	TIN76			GTM input
	ARX1B			ASCLIN1 input
	MTSR2A			QSPI2 input
	REQ13			SCU input
	SDA0C			I2C0 input
	P15.5			O0
	TOUT76	O1		GTM output
	ATX1	O2		ASCLIN1 output
	MTSR2	O3		QSPI2 output
	END02	O4		MSC0 output
	EN00	O5		MSC0 output
	SDA0	O6		I2C0 output
	CC61	O7		CCU60 output
F21	P15.6	I	MP / PU1 / VEXT	General-purpose input
	TIN77			GTM input
	MTSR2B			QSPI2 input
	P15.6	O0		General-purpose output
	TOUT77	O1		GTM output
	ATX3	O2		ASCLIN3 output
	MTSR2	O3		QSPI2 output
	SLSO53	O4		QSPI5 output
	SCLK2	O5		QSPI2 output
	ASCLK3	O6		ASCLIN3 output
CC60	O7	CCU60 output		
J20	P15.7	I	MP / PU1 / VEXT	General-purpose input
	TIN78			GTM input
	ARX3A			ASCLIN3 input
	MRST2B			QSPI2 input
	P15.7	O0		General-purpose output
	TOUT78	O1		GTM output
	ATX3	O2		ASCLIN3 output
	MRST2	O3		QSPI2 output
	–	O4		Reserved
	–	O5		Reserved
	–	O6		Reserved
	COUT60	O7		CCU60 output

Package and Pinning Definitions TC299x Pin Definition and Functions:

Table 2-9 Port 15 Functions (cont'd)

Pin	Symbol	Ctrl	Type	Function
J19	P15.8	I	MP / PU1 / VEXT	General-purpose input
	TIN79			GTM input
	SCLK2B			QSPI2 input
	REQ1			SCU input
	P15.8	O0		General-purpose output
	TOUT79	O1		GTM output
	—	O2		Reserved
	SCLK2	O3		QSPI2 output
	—	O4		Reserved
	—	O5		Reserved
	ASCLK3	O6		ASCLIN3 output
COU61	O7	CCU60 output		
B24	P15.10	I	LP / PU1 / VEXT	General-purpose input
	TIN242			GTM input
	MRST5A			QSPI5 input
	P15.10			O0
	TOUT242	O1		GTM output
	—	O2		Reserved
	MRST5	O3		QSPI5 output
	—	O4		Reserved
	—	O5		Reserved
	—	O6		Reserved
	—	O7		Reserved
A24	P15.11	I	LP / PU1 / VEXT	General-purpose input
	TIN243			GTM input
	SLSI5A			QSPI5 input
	P15.11			O0
	TOUT243	O1		GTM output
	—	O2		Reserved
	SLSO52	O3		QSPI5 output
	—	O4		Reserved
	—	O5		Reserved
	—	O6		Reserved
	—	O7		Reserved

Package and Pinning Definitions TC299x Pin Definition and Functions:

Table 2-9 Port 15 Functions (cont'd)

Pin	Symbol	Ctrl	Type	Function
B23	P15.12	I	LP / PU1 / VEXT	General-purpose input
	TIN244			GTM input
	P15.12	O0		General-purpose output
	TOUT244	O1		GTM output
	—	O2		Reserved
	SLSO51	O3		QSPI5 output
	—	O4		Reserved
	—	O5		Reserved
	—	O6		Reserved
	—	O7		Reserved
A23	P15.13	I	LP / PU1 / VEXT	General-purpose input
	TIN245			GTM input
	P15.13	O0		General-purpose output
	TOUT245	O1		GTM output
	—	O2		Reserved
	SLSO50	O3		QSPI5 output
	—	O4		Reserved
	—	O5		Reserved
	—	O6		Reserved
	—	O7		Reserved
B22	P15.14	I	MP / PU1 / VEXT	General-purpose input
	TIN246			GTM input
	MTSR5A	O0		QSPI5 input
	P15.14			General-purpose output
	TOUT246	O1		GTM output
	—	O2		Reserved
	MTSR5	O3		QSPI5 output
	—	O4		Reserved
	—	O5		Reserved
	—	O6		Reserved
—	O7	Reserved		

Package and Pinning Definitions TC299x Pin Definition and Functions:

Table 2-9 Port 15 Functions (cont'd)

Pin	Symbol	Ctrl	Type	Function
A22	P15.15	I	MP / PU1 / VEXT	General-purpose input
	TIN247			GTM input
	SCLK5A			QSPI5 input
	P15.15	O0		General-purpose output
	TOUT247	O1		GTM output
	–	O2		Reserved
	SCLK5	O3		QSPI5 output
	–	O4		Reserved
	–	O5		Reserved
	–	O6		Reserved
	–	O7		Reserved

Table 2-10 Port 20 Functions

Pin	Symbol	Ctrl	Type	Function
N25	P20.0	I	MP / PU1 / VEXT	General-purpose input
	TIN59			GTM input
	RXDCAN3C			CAN node 3 input
	RXDCANr1C			CAN node 1 input (MultiCANr+)
	T6EUDA			GPT120 input
	REQ9			SCU input
	SYSCLK			HSCT input
	TGI0			OCDS input
	P20.0			O0
	TOUT59	O1		GTM output
	ATX3	O2		ASCLIN3 output
	ASCLK3	O3		ASCLIN3 output
	–	O4		Reserved
	SYSCLK	O5		HSCT output
	–	O6		Reserved
	–	O7		Reserved
	TGO0	HWOUT		OCDS; ENx

Package and Pinning Definitions TC299x Pin Definition and Functions:

Table 2-10 Port 20 Functions (cont'd)

Pin	Symbol	Ctrl	Type	Function
M24	P20.1	I	LP / PU1 / VEXT	General-purpose input
	TIN60			GTM input
	TGI1			OCDS input
	P20.1	O0		General-purpose output
	TOUT60	O1		GTM output
	—	O2		Reserved
	—	O3		Reserved
	—	O4		Reserved
	—	O5		Reserved
	—	O6		Reserved
	—	O7		Reserved
	TGO1	HWOU T		OCDS; ENx
N24	P20.2	I	LP / PU1 / VEXT	General-purpose input This pin is latched at power on reset release to enter test mode.
	TESTMODE			OCDS input
	P20.2	O0		Output function not available
	—	O1		Output function not available
	—	O2		Output function not available
	—	O3		Output function not available
	—	O4		Output function not available
	—	O5		Output function not available
	—	O6		Output function not available
	—	O7		Output function not available
M25	P20.3	I	LP / PU1 / VEXT	General-purpose input
	TIN61			GTM input
	T6INA			GPT120 input
	ARX3C			ASCLIN3 input
	P20.3	O0		General-purpose output
	TOUT61	O1		GTM output
	ATX3	O2		ASCLIN3 output
	SLSO09	O3		QSPI0 output
	SLSO29	O4		QSPI2 output
	TXDCAN3	O5		CAN node 3 output
	TXDCANr1	O6		CAN node 1 output (MultiCANr+)
	—	O7		Reserved

Package and Pinning Definitions TC299x Pin Definition and Functions:

Table 2-10 Port 20 Functions (cont'd)

Pin	Symbol	Ctrl	Type	Function
L22	P20.6	I	LP / PU1 / VEXT	General-purpose input
	TIN62			GTM input
	P20.6	O0		General-purpose output
	TOUT62	O1		GTM output
	ARTS1	O2		ASCLIN1 output
	SLSO08	O3		QSPI0 output
	SLSO28	O4		QSPI2 output
	–	O5		Reserved
	WDT2LCK	O6		SCU output
	–	O7		Reserved
L24	P20.7	I	LP / PU1 / VEXT	General-purpose input
	TIN63			GTM input
	ACTS1A			ASCLIN1 input
	RXDCAN0B			CAN node 0 input
	P20.7	O0		General-purpose output
	TOUT63	O1		GTM output
	–	O2		Reserved
	–	O3		Reserved
	–	O4		Reserved
	–	O5		Reserved
	WDT1LCK	O6		SCU output
	COU63	O7		CCU61 output
L25	P20.8	I	MP / PU1 / VEXT	General-purpose input
	TIN64			GTM input
	P20.8	O0		General-purpose output
	TOUT64	O1		GTM output
	ASLSO1	O2		ASCLIN1 output
	SLSO00	O3		QSPI0 output
	SLSO10	O4		QSPI1 output
	TXDCAN0	O5		CAN node 0 output
	WDT0LCK	O6		SCU output
	CC60	O7		CCU61 output

Package and Pinning Definitions TC299x Pin Definition and Functions:

Table 2-10 Port 20 Functions (cont'd)

Pin	Symbol	Ctrl	Type	Function
K22	P20.9	I	LP / PU1 / VEXT	General-purpose input
	TIN65			GTM input
	ARX1C			ASCLIN1 input
	RXDCAN3E			CAN node 3 input
	REQ11			SCU input
	SLSI0B			QSPI0 input
	P20.9			O0
	TOUT65	O1		GTM output
	–	O2		Reserved
	SLSO01	O3		QSPI0 output
	SLSO11	O4		QSPI1 output
	–	O5		Reserved
	WDTSLCK	O6		SCU output
	CC61	O7		CCU61 output
K24	P20.10	I	MP / PU1 / VEXT	General-purpose input
	TIN66			GTM input
	P20.10	O0		General-purpose output
	TOUT66	O1		GTM output
	ATX1	O2		ASCLIN1 output
	SLSO06	O3		QSPI0 output
	SLSO27	O4		QSPI2 output
	TXDCAN3	O5		CAN node 3 output
	ASCLK1	O6		ASCLIN1 output
	CC62	O7		CCU61 output
K25	P20.11	I	MP / PU1 / VEXT	General-purpose input
	TIN67			GTM input
	SCLK0A			QSPI0 input
	P20.11	O0		General-purpose output
	TOUT67	O1		GTM output
	–	O2		Reserved
	SCLK0	O3		QSPI0 output
	–	O4		Reserved
	–	O5		Reserved
	–	O6		Reserved
	COU60	O7		CCU61 output

Package and Pinning Definitions TC299x Pin Definition and Functions:

Table 2-10 Port 20 Functions (cont'd)

Pin	Symbol	Ctrl	Type	Function
J24	P20.12	I	MP / PU1 / VEXT	General-purpose input
	TIN68			GTM input
	MRST0A			QSPI0 input
	P20.12	O0		General-purpose output
	TOUT68	O1		GTM output
	–	O2		Reserved
	MRST0	O3		QSPI0 output
	MTRS0	O4		QSPI0 output
	–	O5		Reserved
	–	O6		Reserved
COU61	O7	CCU61 output		
J25	P20.13	I	MP / PU1 / VEXT	General-purpose input
	TIN69			GTM input
	SLSI0A			QSPI0 input
	P20.13	O0		General-purpose output
	TOUT69	O1		GTM output
	–	O2		Reserved
	SLSO02	O3		QSPI0 output
	SLSO12	O4		QSPI1 output
	SCLK0	O5		QSPI0 output
	–	O6		Reserved
COU62	O7	CCU61 output		
H25	P20.14	I	MP / PU1 / VEXT	General-purpose input
	TIN70			GTM input
	MTRS0A			QSPI0 input
	P20.14	O0		General-purpose output
	TOUT70	O1		GTM output
	–	O2		Reserved
	MTRS0	O3		QSPI0 output
	–	O4		Reserved
	–	O5		Reserved
	–	O6		Reserved
–	O7	Reserved		

Package and Pinning Definitions TC299x Pin Definition and Functions:

Table 2-11 Port 21 Functions

Pin	Symbol	Ctrl	Type	Function
R22	P21.0	I	LVDSH_N/ PU1 / VDDP3	General-purpose input
	TIN51			GTM input
	MRST4DN			QSPI4 input (LVDS)
	HOLD			EBU input
	P21.0	O0		General-purpose output
	TOUT51	O1		GTM output
	–	O2		Reserved
	–	O3		Reserved
	–	O4		Reserved
	–	O5		Reserved
	ETHMDC	O6		ETH output
	BAABA0	O7		EBU output (combined for BAA and BA0)
	HSM1	O		HSM output
	P22	P21.1		I
TIN52		GTM input		
ETHMDIOB		ETH input (Not for production purposes)		
MRST4DP		QSPI4 input (LVDS)		
WAIT		EBU input		
P21.1		O0	General-purpose output	
TOUT52		O1	GTM output	
–		O2	Reserved	
–		O3	Reserved	
–		O4	Reserved	
–		O5	Reserved	
ETHMDIO		O6	ETH output (Not for production purposes)	
BREQBA1		O7	EBU output (combined for BREQ and BA1)	
HSM2		O	HSM output	

Package and Pinning Definitions TC299x Pin Definition and Functions:

Table 2-11 Port 21 Functions (cont'd)

Pin	Symbol	Ctrl	Type	Function
R24	P21.2	I	LVDSH_N/ PU1 / VDDP3	General-purpose input
	TIN53			GTM input
	MRST2CN			QSPI2 input (LVDS)
	MRST4CN			QSPI4 input (LVDS)
	ARX3GN			ASCLIN3 input (LVDS)
	EMGSTOPB			SCU input
	RXDN			HSCT input (LVDS)
	P21.2	O0		General-purpose output
	TOUT53	O1		GTM output
	ASLSO3	O2		ASCLIN3 output
	–	O3		Reserved
	–	O4		Reserved
	ETHMDC	O5		ETH output
	SDRAMA8	O6		EBU output
	–	O7		Reserved
P24	P21.3	I	LVDSH_P/ PU1 / VDDP3	General-purpose input
	TIN54			GTM input
	MRST2CP			QSPI2 input (LVDS)
	MRST4CP			QSPI4 input (LVDS)
	ARX3GP			ASCLIN3 input (LVDS)
	RXDP			HSCT input (LVDS)
	P21.3			O0
	TOUT54	O1		GTM output
	–	O2		Reserved
	–	O3		Reserved
	–	O4		Reserved
	–	O5		Reserved
	SDRAMA9	O6		EBU output
	–	O7		Reserved
	ETHMDIOD	HWOUT		ETH input/output

Package and Pinning Definitions TC299x Pin Definition and Functions:
Table 2-11 Port 21 Functions (cont'd)

Pin	Symbol	Ctrl	Type	Function
R25	P21.4	I	LVDSH_N/ PU1 / VDDP3	General-purpose input
	TIN55			GTM input
	P21.4	O0		General-purpose output
	TOUT55	O1		GTM output
	–	O2		Reserved
	–	O3		Reserved
	–	O4		Reserved
	–	O5		Reserved
	SDRAMA10	O6		EBU output
	–	O7		Reserved
	TXDN	HSCT		HSCT output (LVDS)
P25	P21.5	I	LVDSH_P/ PU1 / VDDP3	General-purpose input
	TIN56			GTM input
	P21.5	O0		General-purpose output
	TOUT56	O1		GTM output
	ASCLK3	O2		ASCLIN3 output
	–	O3		Reserved
	–	O4		Reserved
	–	O5		Reserved
	SDRAMA11	O6		EBU output
	–	O7		Reserved
	TXDP	HSCT		HSCT output (LVDS)
N22	P21.6	I	A2 / PU / VDDP3	General-purpose input
	TIN57			GTM input
	ARX3F			ASCLIN3 input
	$\overline{\text{TGI2}}$			OCDS input
	TDI			OCDS (JTAG) input
	T5EUDA			GPT120 input
	P21.6			O0
	TOUT57	O1		GTM output
	ASLSO3	O2		ASCLIN3 output
	–	O3		Reserved
	–	O4		Reserved
	SYSCLK	O5		HSCT output
	SDRAMA12	O6		EBU output
	T3OUT	O7		GPT120 output
	$\overline{\text{TGO2}}$	HWOUT		OCDS; ENx

Package and Pinning Definitions TC299x Pin Definition and Functions:
Table 2-11 Port 21 Functions (cont'd)

Pin	Symbol	Ctrl	Type	Function
N21	P21.7	I	A2 / PU / VDDP3	General-purpose input
	TIN58			GTM input
	DAP2			OCDS (3-Pin DAP) input In the 3-Pin DAP mode this pin is used as DAP2. In the 2-PIN DAP mode this pin is used as P21.7 and controlled by the related port control logic
	TGI3			OCDS input
	ETHRXERB			ETH input
	T5INA			GPT120 input
	P21.7			O0
	TOUT58	O1		GTM output
	ATX3	O2		ASCLIN3 output
	ASCLK3	O3		ASCLIN3 output
	–	O4		Reserved
	–	O5		Reserved
	SDRAMA13	O6		EBU output
	T6OUT	O7		GPT120 output
	TGO3	HWOUT		OCDS; ENx
	TDO			OCDS (JTAG); ENx The JTAG TDO function is overlaid with P21.7 via a double bond. In JTAG mode this pin is used as TDO, after power-on reset it is HighZ.
	DAP2			OCDS (3-Pin DAP); ENx In the 3-Pin DAP mode this pin is used as DAP2.

Table 2-12 Port 22 Functions

Pin	Symbol	Ctrl	Type	Function
W25	P22.0	I	LVDSM_N / PU1 / VEXT	General-purpose input
	TIN47			GTM input
	MTSR4B			QSPI4 input
	P22.0	O0		General-purpose output
	TOUT47	O1		GTM output
	ATX3N	O2		ASCLIN3 output (LVDS)
	MTSR4	O3		QSPI4 output
	SCLK4N	O4		QSPI4 output (LVDS)
	FCLN1	O5		MSC1 output (LVDS)
	FCLND1	O6		MSC1 output (LVDS)
	–	O7		Reserved

Package and Pinning Definitions TC299x Pin Definition and Functions:

Table 2-12 Port 22 Functions (cont'd)

Pin	Symbol	Ctrl	Type	Function
W24	P22.1	I	LVDSM_P / PU1 / VEXT	General-purpose input
	TIN48			GTM input
	MRST4B			QSPI4 input
	P22.1	O0		General-purpose output
	TOUT48	O1		GTM output
	ATX3P	O2		ASCLIN3 output (LVDS)
	MRST4	O3		QSPI4 output
	SCLK4P	O4		QSPI4 output (LVDS)
	FCLP1	O5		MSC1 output (LVDS)
	–	O6		Reserved
–	O7	Reserved		
Y25	P22.2	I	LVDSM_N / PU1 / VEXT	General-purpose input
	TIN49			GTM input
	SLSI4B			QSPI4 input
	P22.2	O0		General-purpose output
	TOUT49	O1		GTM output
	–	O2		Reserved
	SLSO43	O3		QSPI4 output
	MTSR4N	O4		QSPI4 output (LVDS)
	SON1	O5		MSC1 output (LVDS)
	SOND1	O6		MSC1 output (LVDS)
–	O7	Reserved		
Y24	P22.3	I	LVDSM_P / PU1 / VEXT	General-purpose input
	TIN50			GTM input
	SCLK4B			QSPI4 input
	P22.3	O0		General-purpose output
	TOUT50	O1		GTM output
	–	O2		Reserved
	SCLK4	O3		QSPI4 output
	MTSR4P	O4		QSPI4 output (LVDS)
	SOP1	O5		MSC1 output (LVDS)
	–	O6		Reserved
–	O7	Reserved		

Package and Pinning Definitions TC299x Pin Definition and Functions:

Table 2-12 Port 22 Functions (cont'd)

Pin	Symbol	Ctrl	Type	Function
W21	P22.4	I	LP / PU1 / VEXT	General-purpose input
	TIN130			GTM input
	P22.4			General-purpose output
	TOUT130	O1		GTM output
	–	O2		Reserved
	–	O3		Reserved
	SLSO012	O4		QSPI0 output
	PSITX4	O5		PSI5 output
	–	O6		Reserved
	–	O7		Reserved
W22	P22.5	I	LP / PU1 / VEXT	General-purpose input
	TIN131			GTM input
	MTSR0C			QSPI0 input
	PSIRX4B			PSI5 input
	P22.5	O0		General-purpose output
	TOUT131	O1		GTM output
	–	O2		Reserved
	–	O3		Reserved
	MTSR0	O4		QSPI0 output
	–	O5		Reserved
–	O6	Reserved		
–	O7	Reserved		
V21	P22.6	I	LP / PU1 / VEXT	General-purpose input
	TIN132			GTM input
	MRST0C			QSPI0 input
	P22.6	O0		General-purpose output
	TOUT132	O1		GTM output
	–	O2		Reserved
	–	O3		Reserved
	MRST0	O4		QSPI0 output
	–	O5		Reserved
	–	O6		Reserved
–	O7	Reserved		

Package and Pinning Definitions TC299x Pin Definition and Functions:

Table 2-12 Port 22 Functions (cont'd)

Pin	Symbol	Ctrl	Type	Function
V22	P22.7	I	LP / PU1 / VEXT	General-purpose input
	TIN133			GTM input
	SCLK0C			QSPIO input
	P22.7	O0		General-purpose output
	TOUT133	O1		GTM output
	—	O2		Reserved
	—	O3		Reserved
	SCLK0	O4		QSPIO output
	—	O5		Reserved
	—	O6		Reserved
—	O7	Reserved		
U21	P22.8	I	LP / PU1 / VEXT	General-purpose input
	TIN134			GTM input
	SCLK0B			QSPIO input
	P22.8	O0		General-purpose output
	TOUT134	O1		GTM output
	—	O2		Reserved
	—	O3		Reserved
	SCLK0	O4		QSPIO output
	—	O5		Reserved
	—	O6		Reserved
—	O7	Reserved		
U22	P22.9	I	LP / PU1 / VEXT	General-purpose input
	TIN135			GTM input
	MRST0B			QSPIO input
	P22.9	O0		General-purpose output
	TOUT135	O1		GTM output
	—	O2		Reserved
	—	O3		Reserved
	MRST0	O4		QSPIO output
	—	O5		Reserved
	—	O6		Reserved
—	O7	Reserved		

Package and Pinning Definitions TC299x Pin Definition and Functions:
Table 2-12 Port 22 Functions (cont'd)

Pin	Symbol	Ctrl	Type	Function
T21	P22.10	I	LP / PU1 / VEXT	General-purpose input
	TIN136			GTM input
	MTSR0B			QSPIO input
	P22.10	O0		General-purpose output
	TOUT136	O1		GTM output
	—	O2		Reserved
	—	O3		Reserved
	MTSR0	O4		QSPIO output
	—	O5		Reserved
	—	O6		Reserved
	—	O7		Reserved
T22	P22.11	I	LP / PU1 / VEXT	General-purpose input
	TIN137			GTM input
	P22.11			O0
	TOUT137	O1		GTM output
	—	O2		Reserved
	—	O3		Reserved
	SLSO010	O4		QSPIO output
	—	O5		Reserved
	—	O6		Reserved
	—	O7		Reserved

Table 2-13 Port 23 Functions

Pin	Symbol	Ctrl	Type	Function
AC25	P23.0	I	LP / PU1 / VEXT	General-purpose input
	TIN41			GTM input
	P23.0			O0
	TOUT41	O1		GTM output
	—	O2		Reserved
	—	O3		Reserved
	—	O4		Reserved
	—	O5		Reserved
	—	O6		Reserved
	—	O7		Reserved

Package and Pinning Definitions TC299x Pin Definition and Functions:

Table 2-13 Port 23 Functions (cont'd)

Pin	Symbol	Ctrl	Type	Function
AB24	P23.1	I	MP+ / PU1 / VEXT	General-purpose input
	TIN42			GTM input
	SDI10			MSC1 input
	P23.1	O0		General-purpose output
	TOUT42	O1		GTM output
	ARTS1	O2		ASCLIN1 output
	SLSO46	O3		QSPI4 output
	GTMCLK0	O4		GTM output
	—	O5		Reserved
	EXTCLK0	O6		SCU output
—	O7	Reserved		
AB25	P23.2	I	LP / PU1 / VEXT	General-purpose input
	TIN43			GTM input
	P23.2			General-purpose output
	TOUT43	O1		GTM output
	—	O2		Reserved
	—	O3		Reserved
	—	O4		Reserved
	—	O5		Reserved
	—	O6		Reserved
	—	O7		Reserved
AA24	P23.3	I	LP / PU1 / VEXT	General-purpose input
	TIN44			GTM input
	INJ10			MSC1 input
	P23.3	O0		General-purpose output
	TOUT44	O1		GTM output
	—	O2		Reserved
	—	O3		Reserved
	—	O4		Reserved
	—	O5		Reserved
	—	O6		Reserved
—	O7	Reserved		

Package and Pinning Definitions TC299x Pin Definition and Functions:

Table 2-13 Port 23 Functions (cont'd)

Pin	Symbol	Ctrl	Type	Function
AA25	P23.4	I	MP+ / PU1 / VEXT	General-purpose input
	TIN45			GTM input
	P23.4	O0		General-purpose output
	TOUT45	O1		GTM output
	—	O2		Reserved
	SLSO45	O3		QSPI4 output
	END12	O4		MSC1 output
	EN10	O5		MSC1 output
	—	O6		Reserved
	—	O7		Reserved
AA22	P23.5	I	MP+ / PU1 / VEXT	General-purpose input
	TIN46			GTM input
	P23.5	O0		General-purpose output
	TOUT46	O1		GTM output
	—	O2		Reserved
	SLSO44	O3		QSPI4 output
	END13	O4		MSC1 output
	EN11	O5		MSC1 output
	—	O6		Reserved
	—	O7		Reserved
Y22	P23.6	I	LP / PU1 / VEXT	General-purpose input
	TIN138			GTM input
	P23.6	O0		General-purpose output
	TOUT138	O1		GTM output
	—	O2		Reserved
	—	O3		Reserved
	SLSO011	O4		QSPI0 output
	—	O5		Reserved
	—	O6		Reserved
	—	O7		Reserved

Package and Pinning Definitions TC299x Pin Definition and Functions:
Table 2-13 Port 23 Functions (cont'd)

Pin	Symbol	Ctrl	Type	Function
Y21	P23.7	I	LP / PU1 / VEXT	General-purpose input
	TIN139			GTM input
	P23.7	O0		General-purpose output
	TOUT139	O1		GTM output
	—	O2		Reserved
	—	O3		Reserved
	—	O4		Reserved
	—	O5		Reserved
	—	O6		Reserved
	—	O7		Reserved

Table 2-14 Port 24 Functions

Pin	Symbol	Ctrl	Type	Function
U29	P24.0	I	A2 / PU1 / VEBU	General-purpose input
	TIN222			GTM input
	P24.0	O0		General-purpose output
	TOUT222	O1		GTM output
	—	O2		Reserved
	—	O3		Reserved
	—	O4		Reserved
	—	O5		Reserved
	—	O6		Reserved
	—	O7		Reserved
		DQ11		HWOU
	A11	T		EBU output
U30	P24.1	I	A2 / PU1 / VEBU	General-purpose input
	TIN223			GTM input
	P24.1	O0		General-purpose output
	TOUT223	O1		GTM output
	—	O2		Reserved
	—	O3		Reserved
	—	O4		Reserved
	—	O5		Reserved
	—	O6		Reserved
	—	O7		Reserved
		DQ15		HWOU
	A15	T		EBU output

Package and Pinning Definitions TC299x Pin Definition and Functions:

Table 2-14 Port 24 Functions (cont'd)

Pin	Symbol	Ctrl	Type	Function
T29	P24.2	I	A2 / PU1 / VEBU	General-purpose input
	TIN224			GTM input
	P24.2	O0		General-purpose output
	TOUT224	O1		GTM output
	—	O2		Reserved
	—	O3		Reserved
	—	O4		Reserved
	—	O5		Reserved
	—	O6		Reserved
	—	O7		Reserved
	DQ14	HWOU		EBU Data Bus Line (SDRAM)
	A14	T		EBU output
T30	P24.3	I	A2 / PU1 / VEBU	General-purpose input
	TIN225			GTM input
	P24.3	O0		General-purpose output
	TOUT225	O1		GTM output
	—	O2		Reserved
	—	O3		Reserved
	—	O4		Reserved
	—	O5		Reserved
	—	O6		Reserved
	—	O7		Reserved
	DQ13	HWOU		EBU Data Bus Line (SDRAM)
	A13	T		EBU output
R29	P24.4	I	A2 / PU1 / VEBU	General-purpose input
	TIN226			GTM input
	P24.4	O0		General-purpose output
	TOUT226	O1		GTM output
	—	O2		Reserved
	—	O3		Reserved
	—	O4		Reserved
	—	O5		Reserved
	—	O6		Reserved
	—	O7		Reserved
	DQ9	HWOU		EBU Data Bus Line (SDRAM)
	A9	T		EBU output

Package and Pinning Definitions TC299x Pin Definition and Functions:
Table 2-14 Port 24 Functions (cont'd)

Pin	Symbol	Ctrl	Type	Function
R30	P24.5	I	A2 / PU1 / VEBU	General-purpose input
	TIN227			GTM input
	P24.5	O0		General-purpose output
	TOUT227	O1		GTM output
	—	O2		Reserved
	—	O3		Reserved
	—	O4		Reserved
	—	O5		Reserved
	—	O6		Reserved
	—	O7		Reserved
	DQ12	HWOU		EBU Data Bus Line (SDRAM)
	A12	T		EBU output
P29	P24.6	I	A2 / PU1 / VEBU	General-purpose input
	TIN228			GTM input
	P24.6	O0		General-purpose output
	TOUT228	O1		GTM output
	—	O2		Reserved
	—	O3		Reserved
	—	O4		Reserved
	—	O5		Reserved
	—	O6		Reserved
	—	O7		Reserved
	DQ5	HWOU		EBU Data Bus Line (SDRAM)
	A5	T		EBU output
P30	P24.7	I	A2 / PU1 / VEBU	General-purpose input
	TIN229			GTM input
	P24.7	O0		General-purpose output
	TOUT229	O1		GTM output
	—	O2		Reserved
	—	O3		Reserved
	—	O4		Reserved
	—	O5		Reserved
	—	O6		Reserved
	—	O7		Reserved
	DQ8	HWOU		EBU Data Bus Line (SDRAM)
	A8	T		EBU output

Package and Pinning Definitions TC299x Pin Definition and Functions:

Table 2-14 Port 24 Functions (cont'd)

Pin	Symbol	Ctrl	Type	Function
N29	P24.8	I	A2 / PU1 / VEBU	General-purpose input
	TIN230			GTM input
	P24.8	O0		General-purpose output
	TOUT230	O1		GTM output
	—	O2		Reserved
	—	O3		Reserved
	—	O4		Reserved
	—	O5		Reserved
	—	O6		Reserved
	—	O7		Reserved
	DQ10	HWOU		EBU Data Bus Line (SDRAM)
	A10	T		EBU output
N30	P24.9	I	A2 / PU1 / VEBU	General-purpose input
	TIN231			GTM input
	P24.9	O0		General-purpose output
	TOUT231	O1		GTM output
	—	O2		Reserved
	—	O3		Reserved
	—	O4		Reserved
	—	O5		Reserved
	—	O6		Reserved
	—	O7		Reserved
	DQ6	HWOU		EBU Data Bus Line (SDRAM)
	A6	T		EBU output
M29	P24.10	I	A2 / PU1 / VEBU	General-purpose input
	TIN232			GTM input
	P24.10	O0		General-purpose output
	TOUT232	O1		GTM output
	—	O2		Reserved
	—	O3		Reserved
	—	O4		Reserved
	—	O5		Reserved
	—	O6		Reserved
	—	O7		Reserved
	DQ4	HWOU		EBU Data Bus Line (SDRAM)
	A4	T		EBU output

Package and Pinning Definitions TC299x Pin Definition and Functions:

Table 2-14 Port 24 Functions (cont'd)

Pin	Symbol	Ctrl	Type	Function
M30	P24.11	I	A2 / PU1 / VEBU	General-purpose input
	TIN233			GTM input
	P24.11	O0		General-purpose output
	TOUT233	O1		GTM output
	—	O2		Reserved
	—	O3		Reserved
	—	O4		Reserved
	—	O5		Reserved
	—	O6		Reserved
	—	O7		Reserved
	DQ3	HWOU		EBU Data Bus Line (SDRAM)
	A3	T		EBU output
L29	P24.12	I	A2 / PU1 / VEBU	General-purpose input
	TIN234			GTM input
	P24.12	O0		General-purpose output
	TOUT234	O1		GTM output
	—	O2		Reserved
	—	O3		Reserved
	—	O4		Reserved
	—	O5		Reserved
	—	O6		Reserved
	—	O7		Reserved
	DQ1	HWOU		EBU Data Bus Line (SDRAM)
	A1	T		EBU output
L30	P24.13	I	A2 / PU1 / VEBU	General-purpose input
	TIN235			GTM input
	P24.13	O0		General-purpose output
	TOUT235	O1		GTM output
	—	O2		Reserved
	—	O3		Reserved
	—	O4		Reserved
	—	O5		Reserved
	—	O6		Reserved
	—	O7		Reserved
	DQ2	HWOU		EBU Data Bus Line (SDRAM)
	A2	T		EBU output

Package and Pinning Definitions TC299x Pin Definition and Functions:

Table 2-14 Port 24 Functions (cont'd)

Pin	Symbol	Ctrl	Type	Function
K29	P24.14	I	A2 / PU1 / VEBU	General-purpose input
	TIN236			GTM input
	P24.14	O0		General-purpose output
	TOUT236	O1		GTM output
	—	O2		Reserved
	—	O3		Reserved
	—	O4		Reserved
	—	O5		Reserved
	—	O6		Reserved
	—	O7		Reserved
	DQ0	HWOU		EBU Data Bus Line (SDRAM)
	A0	T		EBU output
K30	P24.15	I	A2 / PU1 / VEBU	General-purpose input
	TIN237			GTM input
	P24.15	O0		General-purpose output
	TOUT237	O1		GTM output
	—	O2		Reserved
	—	O3		Reserved
	—	O4		Reserved
	—	O5		Reserved
	—	O6		Reserved
	—	O7		Reserved
	DQ7	HWOU		EBU Data Bus Line (SDRAM)
	A7	T		EBU output

Package and Pinning Definitions TC299x Pin Definition and Functions:

Table 2-15 Port 25 Functions

Pin	Symbol	Ctrl	Type	Function
AG30	P25.0	I	A2 / PU1 / VEBU	General-purpose input
	TIN206			GTM input
	SDCLKI			EBU input
	P25.0	O0		General-purpose output
	TOUT206	O1		GTM output
	—	O2		Reserved
	—	O3		Reserved
	—	O4		Reserved
	—	O5		Reserved
	—	O6		Reserved
	—	O7		Reserved
	BFCLKO	HWOU		EBU output
	SDCLKO	T		EBU output
AF30	P25.1	I	A2 / PU1 / VEBU	General-purpose input
	TIN207			GTM input
	P25.1			General-purpose output
	TOUT207	O1		GTM output
	—	O2		Reserved
	—	O3		Reserved
	—	O4		Reserved
	—	O5		Reserved
	—	O6		Reserved
	—	O7		Reserved
	$\overline{\text{RD}}$	HWOU		EBU output
	$\overline{\text{RAS}}$	T		EBU output
	AF29	P25.2		I
TIN208		GTM input		
P25.2		General-purpose output		
TOUT208		O1	GTM output	
—		O2	Reserved	
—		O3	Reserved	
—		O4	Reserved	
—		O5	Reserved	
—		O6	Reserved	
—		O7	Reserved	
$\overline{\text{RD}}/\overline{\text{WR}}$		HWOU	EBU output	
$\overline{\text{WR}}$		T	EBU output	

Package and Pinning Definitions TC299x Pin Definition and Functions:

Table 2-15 Port 25 Functions (cont'd)

Pin	Symbol	Ctrl	Type	Function
AE30	P25.3	I	A2 / PU1 / VEBU	General-purpose input
	TIN209			GTM input
	HOLDA			EBU input
	P25.3	O0		General-purpose output
	TOUT209	O1		GTM output
	—	O2		Reserved
	—	O3		Reserved
	—	O4		Reserved
	—	O5		Reserved
	—	O6		Reserved
	BAABA0	O7		EBU output (combined for BAA and BA0)
	CS2	HWOU T		EBU output
	DQM1			EBU output
	HOLDA			EBU output
AE29	P25.4	I	A2 / PU1 / VEBU	General-purpose input
	TIN210			GTM input
	P25.4	O0		General-purpose output
	TOUT210	O1		GTM output
	—	O2		Reserved
	—	O3		Reserved
	—	O4		Reserved
	—	O5		Reserved
	—	O6		Reserved
	—	O7		Reserved
	CS1	HWOU T		EBU output
	DQM0			EBU output
AD30	P25.5	I	A2 / PU1 / VEBU	General-purpose input
	TIN211			GTM input
	P25.5	O0		General-purpose output
	TOUT211	O1		GTM output
	—	O2		Reserved
	—	O3		Reserved
	—	O4		Reserved
	—	O5		Reserved
	—	O6		Reserved
	—	O7		Reserved
	CS0	HWOU T		EBU output

Package and Pinning Definitions TC299x Pin Definition and Functions:

Table 2-15 Port 25 Functions (cont'd)

Pin	Symbol	Ctrl	Type	Function
W29	P25.6	I	A2 / PU1 / VEBU	General-purpose input
	P25.6	O0		General-purpose output
	TOUT212	O1		GTM output
	—	O2		Reserved
	—	O3		Reserved
	—	O4		Reserved
	—	O5		Reserved
	—	O6		Reserved
	—	O7		Reserved
	CKE	HWOUT		EBU output
	AD29	P25.7		I
TIN213			GTM input	
P25.7		O0	General-purpose output	
TOUT213		O1	GTM output	
—		O2	Reserved	
—		O3	Reserved	
—		O4	Reserved	
—		O5	Reserved	
—		O6	Reserved	
—		O7	Reserved	
ADV		HWOUT	EBU output	
CAS	T	EBU output		
AC29	P25.8	I	A2 / PU1 / VEBU	General-purpose input
	TIN214			GTM input
	P25.8	O0		General-purpose output
	TOUT214	O1		GTM output
	—	O2		Reserved
	—	O3		Reserved
	—	O4		Reserved
	A23	O5		EBU output
	SDRAMA0	O6		EBU output
	—	O7		Reserved
	BC0	HWOUT		EBU output
	T			

Package and Pinning Definitions TC299x Pin Definition and Functions:

Table 2-15 Port 25 Functions (cont'd)

Pin	Symbol	Ctrl	Type	Function
AC30	P25.9	I	A2 / PU1 / VEBU	General-purpose input
	TIN215			GTM input
	P25.9	O0		General-purpose output
	TOUT215	O1		GTM output
	—	O2		Reserved
	—	O3		Reserved
	—	O4		Reserved
	A22	O5		EBU output
	SDRAMA1	O6		EBU output
	—	O7		Reserved
	BC1	HWOUT		EBU output
	T			
AB29	P25.10	I	A2 / PU1 / VEBU	General-purpose input
	TIN216			GTM input
	P25.10	O0		General-purpose output
	TOUT216	O1		GTM output
	—	O2		Reserved
	—	O3		Reserved
	—	O4		Reserved
	A21	O5		EBU output
	SDRAMA2	O6		EBU output
	—	O7		Reserved
	BC2	HWOUT		EBU output
	T			
AB30	P25.11	I	A2 / PU1 / VEBU	General-purpose input
	TIN217			GTM input
	P25.11	O0		General-purpose output
	TOUT217	O1		GTM output
	—	O2		Reserved
	—	O3		Reserved
	—	O4		Reserved
	A20	O5		EBU output
	SDRAMA3	O6		EBU output
	—	O7		Reserved
	BC3	HWOUT		EBU output
	T			

Package and Pinning Definitions TC299x Pin Definition and Functions:

Table 2-15 Port 25 Functions (cont'd)

Pin	Symbol	Ctrl	Type	Function
AA29	P25.12	I	A2 / PU1 / VEBU	General-purpose input
	TIN218			GTM input
	P25.12	O0		General-purpose output
	TOUT218	O1		GTM output
	—	O2		Reserved
	—	O3		Reserved
	—	O4		Reserved
	—	O5		Reserved
	SDRAMA4	O6		EBU output
	—	O7		Reserved
	A19	HWOUT		EBU output
AA30	P25.13	I	A2 / PU1 / VEBU	General-purpose input
	TIN219			GTM input
	P25.13	O0		General-purpose output
	TOUT219	O1		GTM output
	—	O2		Reserved
	—	O3		Reserved
	—	O4		Reserved
	—	O5		Reserved
	SDRAMA5	O6		EBU output
	—	O7		Reserved
	A17	HWOUT		EBU output
Y29	P25.14	I	A2 / PU1 / VEBU	General-purpose input
	TIN220			GTM input
	P25.14	O0		General-purpose output
	TOUT220	O1		GTM output
	—	O2		Reserved
	—	O3		Reserved
	—	O4		Reserved
	—	O5		Reserved
	SDRAMA6	O6		EBU output
	—	O7		Reserved
	A18	HWOUT		EBU output

Package and Pinning Definitions TC299x Pin Definition and Functions:

Table 2-15 Port 25 Functions (cont'd)

Pin	Symbol	Ctrl	Type	Function
Y30	P25.15	I	A2 / PU1 / VEBU	General-purpose input
	TIN221			GTM input
	P25.15	O0		General-purpose output
	TOUT221	O1		GTM output
	—	O2		Reserved
	—	O3		Reserved
	—	O4		Reserved
	—	O5		Reserved
	SDRAMA7	O6		EBU output
	—	O7		Reserved
	A16	HWOUT		EBU output

Table 2-16 Port 26 Functions

Pin	Symbol	Ctrl	Type	Function
AG29	P26.0	I	LP / PU1 / VFLEXE	General-purpose input
	TIN212			GTM input
	BFCLKI			EBU input
	P26.0	O0		General-purpose output
	TOUT212	O1		GTM output
	—	O2		Reserved
	—	O3		Reserved
	—	O4		Reserved
	—	O5		Reserved
	—	O6		Reserved
	—	O7		Reserved

Package and Pinning Definitions TC299x Pin Definition and Functions:

Table 2-17 Port 30 Functions

Pin	Symbol	Ctrl	Type	Function
AJ21	P30.0	I	MP / PU1 / VFLEXE	General-purpose input
	TIN190			GTM input
	P30.0	O0		General-purpose output
	TOUT190	O1		GTM output
	—	O2		Reserved
	—	O3		Reserved
	—	O4		Reserved
	—	O5		Reserved
	—	O6		Reserved
	—	O7		Reserved
	AD14	HWOUT		EBU Address / Data Bus Line
AK21	P30.1	I	MP / PU1 / VFLEXE	General-purpose input
	TIN191			GTM input
	P30.1	O0		General-purpose output
	TOUT191	O1		GTM output
	—	O2		Reserved
	—	O3		Reserved
	—	O4		Reserved
	—	O5		Reserved
	—	O6		Reserved
	—	O7		Reserved
	AD11	HWOUT		EBU Address / Data Bus Line
AJ22	P30.2	I	MP / PU1 / VFLEXE	General-purpose input
	TIN192			GTM input
	P30.2	O0		General-purpose output
	TOUT192	O1		GTM output
	—	O2		Reserved
	—	O3		Reserved
	—	O4		Reserved
	—	O5		Reserved
	—	O6		Reserved
	—	O7		Reserved
	AD12	HWOUT		EBU Address / Data Bus Line

Package and Pinning Definitions TC299x Pin Definition and Functions:

Table 2-17 Port 30 Functions (cont'd)

Pin	Symbol	Ctrl	Type	Function
AK22	P30.3	I	MP / PU1 / VFLEXE	General-purpose input
	TIN193			GTM input
	P30.3	O0		General-purpose output
	TOUT193	O1		GTM output
	—	O2		Reserved
	—	O3		Reserved
	—	O4		Reserved
	—	O5		Reserved
	—	O6		Reserved
	—	O7		Reserved
	AD15	HWOUT		EBU Address / Data Bus Line
	AJ23	P30.4		I
TIN194		GTM input		
P30.4		O0	General-purpose output	
TOUT194		O1	GTM output	
—		O2	Reserved	
—		O3	Reserved	
—		O4	Reserved	
—		O5	Reserved	
—		O6	Reserved	
—		O7	Reserved	
AD8		HWOUT	EBU Address / Data Bus Line	
AK23		P30.5	I	MP / PU1 / VFLEXE
	TIN195	GTM input		
	P30.5	O0	General-purpose output	
	TOUT195	O1	GTM output	
	—	O2	Reserved	
	—	O3	Reserved	
	—	O4	Reserved	
	—	O5	Reserved	
	—	O6	Reserved	
	—	O7	Reserved	
	AD13	HWOUT	EBU Address / Data Bus Line	

Package and Pinning Definitions TC299x Pin Definition and Functions:
Table 2-17 Port 30 Functions (cont'd)

Pin	Symbol	Ctrl	Type	Function
AJ24	P30.6	I	MP / PU1 / VFLEXE	General-purpose input
	TIN196			GTM input
	P30.6	O0		General-purpose output
	TOUT196	O1		GTM output
	—	O2		Reserved
	—	O3		Reserved
	—	O4		Reserved
	—	O5		Reserved
	—	O6		Reserved
	—	O7		Reserved
	AD4	HWOUT		EBU Address / Data Bus Line
	AK24	P30.7		I
TIN197		GTM input		
P30.7		O0	General-purpose output	
TOUT197		O1	GTM output	
—		O2	Reserved	
—		O3	Reserved	
—		O4	Reserved	
—		O5	Reserved	
—		O6	Reserved	
—		O7	Reserved	
AD7		HWOUT	EBU Address / Data Bus Line	
AJ25		P30.8	I	MP / PU1 / VFLEXE
	TIN198	GTM input		
	P30.8	O0	General-purpose output	
	TOUT198	O1	GTM output	
	—	O2	Reserved	
	—	O3	Reserved	
	—	O4	Reserved	
	—	O5	Reserved	
	—	O6	Reserved	
	—	O7	Reserved	
	AD3	HWOUT	EBU Address / Data Bus Line	

Package and Pinning Definitions TC299x Pin Definition and Functions:
Table 2-17 Port 30 Functions (cont'd)

Pin	Symbol	Ctrl	Type	Function
AK25	P30.9	I	MP / PU1 / VFLEXE	General-purpose input
	TIN199			GTM input
	P30.9	O0		General-purpose output
	TOUT199	O1		GTM output
	—	O2		Reserved
	—	O3		Reserved
	—	O4		Reserved
	—	O5		Reserved
	—	O6		Reserved
	—	O7		Reserved
	AD0	HWOUT		EBU Address / Data Bus Line
AJ26	P30.10	I	MP / PU1 / VFLEXE	General-purpose input
	TIN200			GTM input
	P30.10	O0		General-purpose output
	TOUT200	O1		GTM output
	—	O2		Reserved
	—	O3		Reserved
	—	O4		Reserved
	—	O5		Reserved
	—	O6		Reserved
	—	O7		Reserved
	AD5	HWOUT		EBU Address / Data Bus Line
AK26	P30.11	I	MP / PU1 / VFLEXE	General-purpose input
	TIN201			GTM input
	P30.11	O0		General-purpose output
	TOUT201	O1		GTM output
	—	O2		Reserved
	—	O3		Reserved
	—	O4		Reserved
	—	O5		Reserved
	—	O6		Reserved
	—	O7		Reserved
	AD10	HWOUT		EBU Address / Data Bus Line

Package and Pinning Definitions TC299x Pin Definition and Functions:
Table 2-17 Port 30 Functions (cont'd)

Pin	Symbol	Ctrl	Type	Function
AJ27	P30.12	I	MP / PU1 / VFLEXE	General-purpose input
	TIN202			GTM input
	P30.12	O0		General-purpose output
	TOUT202	O1		GTM output
	—	O2		Reserved
	—	O3		Reserved
	—	O4		Reserved
	—	O5		Reserved
	—	O6		Reserved
	—	O7		Reserved
	AD9	HWOUT		EBU Address / Data Bus Line
AK27	P30.13	I	MP / PU1 / VFLEXE	General-purpose input
	TIN203			GTM input
	P30.13	O0		General-purpose output
	TOUT203	O1		GTM output
	—	O2		Reserved
	—	O3		Reserved
	—	O4		Reserved
	—	O5		Reserved
	—	O6		Reserved
	—	O7		Reserved
	AD2	HWOUT		EBU Address / Data Bus Line
AJ28	P30.14	I	MP / PU1 / VFLEXE	General-purpose input
	TIN204			GTM input
	P30.14	O0		General-purpose output
	TOUT204	O1		GTM output
	—	O2		Reserved
	—	O3		Reserved
	—	O4		Reserved
	—	O5		Reserved
	—	O6		Reserved
	—	O7		Reserved
	AD1	HWOUT		EBU Address / Data Bus Line

Package and Pinning Definitions TC299x Pin Definition and Functions:

Table 2-17 Port 30 Functions (cont'd)

Pin	Symbol	Ctrl	Type	Function
AK28	P30.15	I	MP / PU1 / VFLEXE	General-purpose input
	TIN205			GTM input
	P30.15	O0		General-purpose output
	TOUT205	O1		GTM output
	—	O2		Reserved
	—	O3		Reserved
	—	O4		Reserved
	—	O5		Reserved
	—	O6		Reserved
	—	O7		Reserved
	AD6	HWOUT		EBU Address / Data Bus Line

Table 2-18 Port 31 Functions

Pin	Symbol	Ctrl	Type	Function
AJ12	P31.0	I	MP / PU1 / VFLEXE	General-purpose input
	TIN174			GTM input
	P31.0	O0		General-purpose output
	TOUT174	O1		GTM output
	—	O2		Reserved
	—	O3		Reserved
	—	O4		Reserved
	—	O5		Reserved
	—	O6		Reserved
	—	O7		Reserved
	AD30	HWOUT		EBU Address / Data Bus Line
	AK12	P31.1		I
TIN175		GTM input		
P31.1		O0	General-purpose output	
TOUT175		O1	GTM output	
—		O2	Reserved	
—		O3	Reserved	
—		O4	Reserved	
—		O5	Reserved	
—		O6	Reserved	
—		O7	Reserved	
AD29		HWOUT	EBU Address / Data Bus Line	

Package and Pinning Definitions TC299x Pin Definition and Functions:

Table 2-18 Port 31 Functions (cont'd)

Pin	Symbol	Ctrl	Type	Function
AJ13	P31.2	I	MP / PU1 / VFLEXE	General-purpose input
	TIN176			GTM input
	P31.2	O0		General-purpose output
	TOUT176	O1		GTM output
	—	O2		Reserved
	—	O3		Reserved
	—	O4		Reserved
	—	O5		Reserved
	—	O6		Reserved
	—	O7		Reserved
	AD28	HWOUT		EBU Address / Data Bus Line
AK13	P31.3	I	MP / PU1 / VFLEXE	General-purpose input
	TIN177			GTM input
	P31.3	O0		General-purpose output
	TOUT177	O1		GTM output
	—	O2		Reserved
	—	O3		Reserved
	—	O4		Reserved
	—	O5		Reserved
	—	O6		Reserved
	—	O7		Reserved
	AD26	HWOUT		EBU Address / Data Bus Line
AJ14	P31.4	I	MP / PU1 / VFLEXE	General-purpose input
	TIN178			GTM input
	P31.4	O0		General-purpose output
	TOUT178	O1		GTM output
	—	O2		Reserved
	—	O3		Reserved
	—	O4		Reserved
	—	O5		Reserved
	—	O6		Reserved
	—	O7		Reserved
	AD24	HWOUT		EBU Address / Data Bus Line

Package and Pinning Definitions TC299x Pin Definition and Functions:
Table 2-18 Port 31 Functions (cont'd)

Pin	Symbol	Ctrl	Type	Function
AK14	P31.5	I	MP / PU1 / VFLEXE	General-purpose input
	TIN179			GTM input
	P31.5	O0		General-purpose output
	TOUT179	O1		GTM output
	—	O2		Reserved
	—	O3		Reserved
	—	O4		Reserved
	—	O5		Reserved
	—	O6		Reserved
	—	O7		Reserved
	AD23	HWOUT		EBU Address / Data Bus Line
AJ15	P31.6	I	MP / PU1 / VFLEXE	General-purpose input
	TIN180			GTM input
	P31.6	O0		General-purpose output
	TOUT180	O1		GTM output
	—	O2		Reserved
	—	O3		Reserved
	—	O4		Reserved
	—	O5		Reserved
	—	O6		Reserved
	—	O7		Reserved
	AD20	HWOUT		EBU Address / Data Bus Line
AK15	P31.7	I	MP / PU1 / VFLEXE	General-purpose input
	TIN181			GTM input
	P31.7	O0		General-purpose output
	TOUT181	O1		GTM output
	—	O2		Reserved
	—	O3		Reserved
	—	O4		Reserved
	—	O5		Reserved
	—	O6		Reserved
	—	O7		Reserved
	AD16	HWOUT		EBU Address / Data Bus Line

Package and Pinning Definitions TC299x Pin Definition and Functions:
Table 2-18 Port 31 Functions (cont'd)

Pin	Symbol	Ctrl	Type	Function
AJ16	P31.8	I	MP / PU1 / VFLEXE	General-purpose input
	TIN182			GTM input
	P31.8	O0		General-purpose output
	TOUT182	O1		GTM output
	—	O2		Reserved
	—	O3		Reserved
	—	O4		Reserved
	—	O5		Reserved
	—	O6		Reserved
	—	O7		Reserved
	AD31	HWOUT		EBU Address / Data Bus Line
AK16	P31.9	I	MP / PU1 / VFLEXE	General-purpose input
	TIN183			GTM input
	P31.9	O0		General-purpose output
	TOUT183	O1		GTM output
	—	O2		Reserved
	—	O3		Reserved
	—	O4		Reserved
	—	O5		Reserved
	—	O6		Reserved
	—	O7		Reserved
	AD27	HWOUT		EBU Address / Data Bus Line
AJ17	P31.10	I	MP / PU1 / VFLEXE	General-purpose input
	TIN184			GTM input
	P31.10	O0		General-purpose output
	TOUT184	O1		GTM output
	—	O2		Reserved
	—	O3		Reserved
	—	O4		Reserved
	—	O5		Reserved
	—	O6		Reserved
	—	O7		Reserved
	AD21	HWOUT		EBU Address / Data Bus Line

Package and Pinning Definitions TC299x Pin Definition and Functions:

Table 2-18 Port 31 Functions (cont'd)

Pin	Symbol	Ctrl	Type	Function
AK17	P31.11	I	MP / PU1 / VFLEXE	General-purpose input
	TIN185			GTM input
	P31.11	O0		General-purpose output
	TOUT185	O1		GTM output
	—	O2		Reserved
	—	O3		Reserved
	—	O4		Reserved
	—	O5		Reserved
	—	O6		Reserved
	—	O7		Reserved
	AD25	HWOUT		EBU Address / Data Bus Line
AJ18	P31.12	I	MP / PU1 / VFLEXE	General-purpose input
	TIN186			GTM input
	P31.12	O0		General-purpose output
	TOUT186	O1		GTM output
	—	O2		Reserved
	—	O3		Reserved
	—	O4		Reserved
	—	O5		Reserved
	—	O6		Reserved
	—	O7		Reserved
	AD19	HWOUT		EBU Address / Data Bus Line
AK18	P31.13	I	MP / PU1 / VFLEXE	General-purpose input
	TIN187			GTM input
	P31.13	O0		General-purpose output
	TOUT187	O1		GTM output
	—	O2		Reserved
	—	O3		Reserved
	—	O4		Reserved
	—	O5		Reserved
	—	O6		Reserved
	—	O7		Reserved
	AD22	HWOUT		EBU Address / Data Bus Line

Package and Pinning Definitions TC299x Pin Definition and Functions:

Table 2-18 Port 31 Functions (cont'd)

Pin	Symbol	Ctrl	Type	Function
AJ19	P31.14	I	MP / PU1 / VFLEXE	General-purpose input
	TIN188			GTM input
	P31.14	O0		General-purpose output
	TOUT188	O1		GTM output
	—	O2		Reserved
	—	O3		Reserved
	—	O4		Reserved
	—	O5		Reserved
	—	O6		Reserved
	—	O7		Reserved
	AD18	HWOUT		EBU Address / Data Bus Line
	AK19	P31.15		I
TIN189		GTM input		
P31.15		O0	General-purpose output	
TOUT189		O1	GTM output	
—		O2	Reserved	
—		O3	Reserved	
—		O4	Reserved	
—		O5	Reserved	
—		O6	Reserved	
—		O7	Reserved	
AD17		HWOUT	EBU Address / Data Bus Line	

Package and Pinning Definitions TC299x Pin Definition and Functions:

Table 2-19 Port 32 Functions

Pin	Symbol	Ctrl	Type	Function
AE22	P32.0	I	LP / PX/ VEXT	General-purpose input
	TIN36			GTM input
	FDEST			PMU input
	VGATE1N			SMPS mode: analog output. External Pass Device gate control for EVR13
	P32.0	O0		General-purpose output
	TOUT36	O1		GTM output
	–	O2		Reserved
	–	O3		Reserved
	–	O4		Reserved
	–	O5		Reserved
	–	O6		Reserved
	–	O7		Reserved
AE23	P32.2	I	LP / PU1 / VEXT	General-purpose input
	TIN38			GTM input
	ARX3D			ASCLIN3 input
	RXDCAN3B			CAN node 3 input
	RXDCANr1D			CAN node 1 input (MultiCANr+)
	P32.2	O0		General-purpose output
	TOUT38	O1		GTM output
	ATX3	O2		ASCLIN3 output
	–	O3		Reserved
	–	O4		Reserved
	–	O5		Reserved
	DCDCSYNC	O6		SCU output
–	O7	Reserved		
AE24	P32.3	I	LP / PU1 / VEXT	General-purpose input
	TIN39			GTM input
	P32.3	O0		General-purpose output
	TOUT39	O1		GTM output
	ATX3	O2		ASCLIN3 output
	–	O3		Reserved
	ASCLK3	O4		ASCLIN3 output
	TXDCAN3	O5		CAN node 3 output
	TXDCANr1	O6		CAN node 1 output (MultiCANr+)
	–	O7		Reserved

Package and Pinning Definitions TC299x Pin Definition and Functions:
Table 2-19 Port 32 Functions (cont'd)

Pin	Symbol	Ctrl	Type	Function
AD23	P32.4	I	MP+ / PU1 / VEXT	General-purpose input
	TIN40			GTM input
	ACTS1B			ASCLIN1 input
	SDI12			MSC1 input
	P32.4	O0		General-purpose output
	TOUT40	O1		GTM output
	–	O2		Reserved
	END12	O3		MSC1 output
	GTMCLK1	O4		GTM output
	EN10	O5		MSC1 output
	EXTCLK1	O6		SCU output
	COU63	O7		CCU60 output
AA20	P32.5	I	LP / PU1 / VEXT	General-purpose input
	TIN140			GTM input
	P32.5	O0		General-purpose output
	TOUT140	O1		GTM output
	ATX2	O2		ASCLIN2 output
	–	O3		Reserved
	–	O4		Reserved
	–	O5		Reserved
	TXDCAN2	O6		CAN node 2 output
	–	O7		Reserved
AB20	P32.6	I	LP / PU1 / VEXT	General-purpose input
	TGI4			OCDS input
	TIN141			GTM input
	RXDCAN2C			CAN node 2 input
	ARX2F			ASCLIN2 input
	P32.6	O0		General-purpose output
	TOUT141	O1		GTM output
	–	O2		Reserved
	–	O3		Reserved
	SLSO212	O4		QSPI2 output
	–	O5		Reserved
	–	O6		Reserved
	–	O7		Reserved
	TGO4	HWOUT		OCDS; ENx

Package and Pinning Definitions TC299x Pin Definition and Functions:

Table 2-19 Port 32 Functions (cont'd)

Pin	Symbol	Ctrl	Type	Function
AB21	P32.7	I	LP / PU1 / VEXT	General-purpose input
	TIN142			GTM input
	TGI5			OCDS input
	P32.7	O0		General-purpose output
	TOUT142	O1		GTM output
	—	O2		Reserved
	—	O3		Reserved
	—	O4		Reserved
	—	O5		Reserved
	—	O6		Reserved
	—	O7		Reserved
	TGO5	HWOUT		OCDS; ENx

Table 2-20 Port 33 Functions

Pin	Symbol	Ctrl	Type	Function
AD15	P33.0	I	LP / PU1 / VEXT	General-purpose input
	TIN22			GTM input
	DSITR0E			DSADC channel 0 input E
	P33.0	O0		General-purpose output
	TOUT22	O1		GTM output
	—	O2		Reserved
	—	O3		Reserved
	—	O4		Reserved
	—	O5		Reserved
	VADCG2BFL0	O6		VADC output
	—	O7		Reserved

Package and Pinning Definitions TC299x Pin Definition and Functions:

Table 2-20 Port 33 Functions (cont'd)

Pin	Symbol	Ctrl	Type	Function
AE15	P33.1	I	LP / PU1 / VEXT	General-purpose input
	TIN23			GTM input
	PSIRX0C			PSI5 input
	SENT9C			SENT input
	DSCIN2B			DSADC channel 2 input B
	DSITR1E			DSADC channel 1 input E
	P33.1			O0
	TOUT23	O1		GTM output
	ASLSO3	O2		ASCLIN3 output
	SCLK2	O3		QSPI2 output
	DSCOUT2	O4		DSADC channel 2 output
	VADCEMUX02	O5		VADC output
	VADCG2BFL1	O6		VADC output
	–	O7		Reserved
AD16	P33.2	I	LP / PU1 / VEXT	General-purpose input
	TIN24			GTM input
	SENT8C			SENT input
	DSDIN2B			DSADC channel 2 input B
	DSITR2E			DSADC channel 2 input E
	P33.2	O0		General-purpose output
	TOUT24	O1		GTM output
	ASCLK3	O2		ASCLIN3 output
	SLSO210	O3		QSPI2 output
	PSITX0	O4		PSI5 output
	VADCEMUX01	O5		VADC output
	VADCG2BFL2	O6		VADC output
	–	O7		Reserved

Package and Pinning Definitions TC299x Pin Definition and Functions:

Table 2-20 Port 33 Functions (cont'd)

Pin	Symbol	Ctrl	Type	Function
AE16	P33.3	I	LP / PU1 / VEXT	General-purpose input
	TIN25			GTM input
	PSIRX1C			PSI5 input
	SENT7C			SENT input
	DSCIN1B			DSADC channel 1 input B
	P33.3			O0
	TOUT25	O1		GTM output
	–	O2		Reserved
	–	O3		Reserved
	DSCOUT1	O4		DSADC channel 1 output
	VADCEMUX00	O5		VADC output
	VADCG2BFL3	O6		VADC output
	–	O7		Reserved
	AD17	P33.4		I
TIN26		GTM input		
SENT6C		SENT input		
CTR \overline APC		CCU61 input		
DSDIN1B		DSADC channel 1 input		
DSITR0F		DSADC channel 0 input F		
P33.4		O0	General-purpose output	
TOUT26		O1	GTM output	
ARTS2		O2	ASCLIN2 output	
SLSO212		O3	QSPI2 output	
PSITX1		O4	PSI5 output	
VADCEMUX12		O5	VADC output	
VADCG0BFL0		O6	VADC output	
–		O7	Reserved	

Package and Pinning Definitions TC299x Pin Definition and Functions:

Table 2-20 Port 33 Functions (cont'd)

Pin	Symbol	Ctrl	Type	Function
AE17	P33.5	I	LP / PU1 / VEXT	General-purpose input
	TIN27			GTM input
	ACTS2B			ASCLIN2 input
	PSIRX2C			PSI5 input
	PSISRXC			PSI5-S input
	SENT5C			SENT input
	CCPOS2C			CCU61 input
	T4EADB			GPT120 input
	DSCIN0B			DSADC channel 0 input B
	DSITR1F			DSADC channel 1 input F
	P33.5			O0
	TOUT27	O1	GTM output	
	SLSO07	O2	QSPI0 output	
	SLSO17	O3	QSPI1 output	
	DSCOUT0	O4	DSADC channel 0 output	
	VADCEMUX11	O5	VADC output	
	VADCG0BFL1	O6	VADC output	
	–	O7	Reserved	
	AD18	P33.6	I	LP / PU1 / VEXT
TIN28		GTM input		
SENT4C		SENT input		
CCPOS1C		CCU61 input		
T2EADB		GPT120 input		
DSDIN0B		DSADC channel 0 input B		
DSITR2F		DSADC channel 2 input F		
P33.6		O0	General-purpose output	
TOUT28		O1	GTM output	
ASLSO2		O2	ASCLIN2 output	
SLSO211		O3	QSPI2 output	
PSITX2		O4	PSI5 output	
VADCEMUX10		O5	VADC output	
VADCG1BFL0		O6	VADC output	
PSISTX		O7	PSI5-S output	

Package and Pinning Definitions TC299x Pin Definition and Functions:

Table 2-20 Port 33 Functions (cont'd)

Pin	Symbol	Ctrl	Type	Function
AE18	P33.7	I	LP / PU1 / VEXT	General-purpose input
	TIN29			GTM input
	RXDCAN0E			CAN node 0 input
	REQ8			SCU input
	CCPOS0C			CCU61 input
	T2INB			GPT120 input
	P33.7			O0
	TOUT29	O1		GTM output
	ASCLK2	O2		ASCLIN2 output
	SLSO47	O3		QSPI4 output
	–	O4		Reserved
	–	O5		Reserved
	VADCG1BFL1	O6		VADC output
	–	O7		Reserved
AD19	P33.8	I	MP / HighZ / VEXT	General-purpose input
	TIN30			GTM input
	ARX2E			ASCLIN2 input
	EMGSTOPA			SCU input
	P33.8	O0		General-purpose output
	TOUT30	O1		GTM output
	ATX2	O2		ASCLIN2 output
	SLSO42	O3		QSPI4 output
	–	O4		Reserved
	TXDCAN0	O5		CAN node 0 output
	–	O6		Reserved
	COUT62	O7		CCU61 output
	SMUFSP	HWOUT		SMU
	AE19	P33.9		I
TIN31		GTM input		
HSIC3INA		QSPI3 input		
P33.9		O0	General-purpose output	
TOUT31		O1	GTM output	
ATX2		O2	ASCLIN2 output	
SLSO41		O3	QSPI4 output	
ASCLK2		O4	ASCLIN2 output	
–		O5	Reserved	
–		O6	Reserved	
CC62		O7	CCU61 output	

Package and Pinning Definitions TC299x Pin Definition and Functions:

Table 2-20 Port 33 Functions (cont'd)

Pin	Symbol	Ctrl	Type	Function
AD20	P33.10	I	MP / PU1 / VEXT	General-purpose input
	TIN32			GTM input
	SLSI4A			QSPI4 input
	HSIC3INB			QSPI3 input
	P33.10	O0		General-purpose output
	TOUT32	O1		GTM output
	SLSO16	O2		QSPI1 output
	SLSO40	O3		QSPI4 output
	ASLSO1	O4		ASCLIN1 output
	PSISCLK	O5		PSI5-S output
	–	O6		Reserved
	COUT61	O7		CCU61 output
AE20	P33.11	I	MP / PU1 / VEXT	General-purpose input
	TIN33			GTM input
	SCLK4A			QSPI4 input
	P33.11			O0
	TOUT33	O1		GTM output
	ASCLK1	O2		ASCLIN1 output
	SCLK4	O3		QSPI4 output
	–	O4		Reserved
	–	O5		Reserved
	DSCGPWMN	O6		DSADC channel output
	CC61	O7		CCU61 output
	AD21	P33.12		I
TIN34		GTM input		
MTSR4A		QSPI4 input		
P33.12		O0	General-purpose output	
TOUT34		O1	GTM output	
ATX1		O2	ASCLIN1 output	
MTSR4		O3	QSPI4 output	
ASCLK1		O4	ASCLIN1 output	
–		O5	Reserved	
DSCGPWMP		O6	DSADC output	
COUT60		O7	CCU61 output	

Package and Pinning Definitions TC299x Pin Definition and Functions:

Table 2-20 Port 33 Functions (cont'd)

Pin	Symbol	Ctrl	Type	Function
AE21	P33.13	I	MP / PU1 / VEXT	General-purpose input
	TIN35			GTM input
	ARX1F			ASCLIN1 input
	MRST4A			QSPI4 input
	DSSGNB			DSADC channel input B
	INJ11			MSC1 input
	P33.13			O0
	TOUT35	O1		GTM output
	ATX1	O2		ASCLIN1 output
	MRST4	O3		QSPI4 output
	SLSO26	O4		QSPI2 output
	–	O5		Reserved
	DCDCSYNC	O6		SCU output
	CC60	O7		CCU61 output
AA19	P33.14	I	LP / PU1 / VEXT	General-purpose input
	TIN143			GTM input
	$\overline{\text{TGI6}}$			OCDS input
	SCLK2D			QSPI2 input
	P33.14			O0
	TOUT143	O1		GTM output
	–	O2		Reserved
	SCLK2	O3		QSPI2 output
	–	O4		Reserved
	–	O5		Reserved
	–	O6		Reserved
	CC62	O7		CCU60 output
	$\overline{\text{TGO6}}$	HWOUT		OCDS; ENx
		T		

Package and Pinning Definitions TC299x Pin Definition and Functions:

Table 2-20 Port 33 Functions (cont'd)

Pin	Symbol	Ctrl	Type	Function
AB19	P33.15	I	LP / PU1 / VEXT	General-purpose input
	TIN144			GTM input
	TGI7			OCDS input
	P33.15	O0		General-purpose output
	TOUT144	O1		GTM output
	—	O2		Reserved
	SLSO211	O3		QSPI2 output
	—	O4		Reserved
	—	O5		Reserved
	—	O6		Reserved
	COU62	O7		CCU60 output
	TGO7	HWOUT		OCDS; ENx

Table 2-21 Port 34 Functions

Pin	Symbol	Ctrl	Type	Function
AB16	P34.1	I	LP / PU1 / VEXT	General-purpose input
	TIN146			GTM input
	P34.1	O0		General-purpose output
	TOUT146	O1		GTM output
	ATX0	O2		ASCLIN0 output
	—	O3		Reserved
	TXDCAN0	O4		CAN node 0 output
	TXDCANr0	O5		CAN node 0 output (MultiCANr+)
	—	O6		Reserved
	COU63	O7		CCU60 output
AA17	P34.2	I	LP / PU1 / VEXT	General-purpose input
	TIN147			GTM input
	ARX0D			ASCLIN0 input
	RXDCAN0G			CAN node 0 input
	RXDCANr0C			CAN node 0 input (MultiCANr+)
	P34.2	O0		General-purpose output
	TOUT147	O1		GTM output
	—	O2		Reserved
	—	O3		Reserved
	—	O4		Reserved
	—	O5		Reserved
	—	O6		Reserved
	CC60	O7		CCU60 output

Package and Pinning Definitions TC299x Pin Definition and Functions:

Table 2-21 Port 34 Functions (cont'd)

Pin	Symbol	Ctrl	Type	Function
AB17	P34.3	I	LP / PU1 / VEXT	General-purpose input
	TIN148			GTM input
	P34.3			General-purpose output
	TOUT148	O0		GTM output
	—	O1		Reserved
	—	O2		Reserved
	—	O3		Reserved
	SLSO210	O4		QSPI2 output
	—	O5		Reserved
	—	O6		Reserved
COUT60	O7	CCU60 output		
AA18	P34.4	I	LP / PU1 / VEXT	General-purpose input
	TIN149			GTM input
	MRST2D			QSPI2 input
	P34.4	O0		General-purpose output
	TOUT149	O1		GTM output
	—	O2		Reserved
	—	O3		Reserved
	MRST2	O4		QSPI2 output
	—	O5		Reserved
	—	O6		Reserved
CC61	O7	CCU60 output		
AB18	P34.5	I	LP / PU1 / VEXT	General-purpose input
	TIN150			GTM input
	MTRSR2D			QSPI2 input
	P34.5	O0		General-purpose output
	TOUT150	O1		GTM output
	—	O2		Reserved
	—	O3		Reserved
	MTRSR2	O4		QSPI2 output
	—	O5		Reserved
	—	O6		Reserved
COUT61	O7	CCU60 output		

Package and Pinning Definitions TC299x Pin Definition and Functions:
Table 2-22 Port 40 Functions

Pin	Symbol	Ctrl	Type	Function
AD7	P40.0	I	S / HighZ / VDDM	General-purpose input
	VADCG3.0			VADC analog input channel 0 of group 3
	DS2PB			DSADC: positive analog input of channel 2, pin B
	CCPOS0D			CCU60 input
	SENT0A			SENT input
AD6	P40.1	I	S / HighZ / VDDM	General-purpose input
	VADCG3.1			VADC analog input channel 1 of group 3 (with pull down diagnostics)
	DS2NB			DSADC: negative analog input channel 2, pin B
	CCPOS1B			CCU60 input
	SENT1A			SENT input
AC7	P40.2	I	S / HighZ / VDDM	General-purpose input
	VADCG3.2			VADC analog input channel 2 of group 3 (with pull down diagnostics)
	CCPOS1D			CCU60 input
	SENT2A			SENT input
AC6	P40.3	I	S / HighZ / VDDM	General-purpose input
	VADCG3.3			VADC analog input channel 3 of group 3 (with pull down diagnostics)
	CCPOS2B			CCU60 input
	SENT3A			SENT input
W9	P40.4	I	S / HighZ / VDDM	General-purpose input
	VADCG4.0			VADC analog input channel 0 of group 4
	CCPOS2D			CCU60 input
	SENT4A			SENT input
Y6	P40.5	I	S / HighZ / VDDM	General-purpose input
	VADCG4.1			VADC analog input channel 1 of group 4
	CCPOS0D			CCU61 input
	SENT5A			SENT input
V9	P40.6	I	S / HighZ / VDDM	General-purpose input
	VADCG4.4			VADC analog input channel 4 of group 4
	DS3PA			DSADC: positive analog input of channel 3, pin A
	CCPOS1B			CCU61 input
	SENT6A			SENT input

Package and Pinning Definitions TC299x Pin Definition and Functions:
Table 2-22 Port 40 Functions (cont'd)

Pin	Symbol	Ctrl	Type	Function
W7	P40.7	I	S / HighZ / VDDM	General-purpose input
	VADCG4.5			VADC analog input channel 5 of group 4
	DS3NA			DSADC: negative analog input channel 3, pin A
	CCPOS1D			CCU61 input
	SENT7A			SENT input
V10	P40.8	I	S / HighZ / VDDM	General-purpose input
	VADCG4.6			VADC analog input channel 6 of group 4
	DS3PB			DSADC: positive analog input of channel 3, pin B
	CCPOS2B			CCU61 input
	SENT8A			SENT input
W6	P40.9	I	S / HighZ / VDDM	General-purpose input
	VADCG4.7			VADC analog input channel 7 of group 4
	DS3NB			DSADC: negative analog input channel 3, pin B
	CCPOS2D			CCU61 input
	SENT9A			SENT input
AA1	P40.10	I	S / HighZ / VDDM	General-purpose input
	VADCG10.3			VADC analog input channel 3 of group 10
	DS8NB			DSADC: negative analog input channel 8, pin B
	SENT10A			SENT input
Y1	P40.11	I	S / HighZ / VDDM	General-purpose input
	VADCG10.4			VADC analog input channel 4 of group 10
	DS8PA			DSADC: positive analog input of channel 8, pin A
	SENT11A			SENT input
Y2	P40.12	I	S / HighZ / VDDM	General-purpose input
	VADCG10.5			VADC analog input channel 5 of group 10
	DS8NA			DSADC: positive analog input of channel 8, pin A
	SENT12A			SENT input
W1	P40.13	I	S / HighZ / VDDM	General-purpose input
	VADCG10.6			VADC analog input channel 6 of group 10
	DS9PA			DSADC: positive analog input of channel 9, pin A
	SENT13A			SENT input
W2	P40.14	I	S / HighZ / VDDM	General-purpose input
	VADCG10.7			VADC analog input channel 7 of group 10
	DS9NA			DSADC: positive analog input of channel 9, pin A
	SENT14A			SENT input

Package and Pinning Definitions TC299x Pin Definition and Functions:
Table 2-23 Analog Inputs

Pin	Symbol	Ctrl	Type	Function
AA15	AN0	I	D / HighZ / VDDM	Analog input 0
	VADCG0.0			VADC analog input channel 0 of group 0
	DS1PA			DSADC: positive analog input of channel 1, pin A
AB15	AN1	I	D / HighZ / VDDM	Analog input 1
	VADCG0.1			VADC analog input channel 1 of group 0
	DS1NA			DSADC: negative analog input channel 1, pin A
AD14	AN2	I	D / HighZ / VDDM	Analog input 2
	VADCG0.2			VADC analog input channel 2 of group 0
	DS0PA			DSADC: positive analog input of channel 0, pin A
AB14	AN3	I	D / HighZ / VDDM	Analog input 3
	VADCG0.3			VADC analog input channel 3 of group 0
	DS0NA			DSADC: negative analog input channel 0, pin A
AA14	AN4	I	D / HighZ / VDDM	Analog input 4
	VADCG0.4			VADC analog input channel 4 of group 0
AE14	AN5	I	D / HighZ / VDDM	Analog input 5
	VADCG0.5			VADC analog input channel 5 of group 0
AA13	AN6	I	D / HighZ / VDDM	Analog input 6
	VADCG0.6			VADC analog input channel 6 of group 0
AB13	AN7	I	D / HighZ / VDDM	Analog input 7
	VADCG0.7			VADC analog input channel 7 of group 0 (with pull down diagnostics)
AD13	AN8	I	D / HighZ / VDDM	Analog input 8
	VADCG1.0			VADC analog input channel 0 of group 1
AB12	AN9	I	D / HighZ / VDDM	Analog input 9
	VADCG1.1			VADC analog input channel 1 of group 1
AE13	AN10	I	D / HighZ / VDDM	Analog input 10
	VADCG1.2			VADC analog input channel 2 of group 1
AD12	AN11	I	D / HighZ / VDDM	Analog input 11
	VADCG1.3			VADC analog input channel 3 of group 1 (with pull down diagnostics)
AA12	AN12	I	D / HighZ / VDDM	Analog input 12
	VADCG1.4			VADC analog input channel 4 of group 1
AD11	AN13	I	D / HighZ / VDDM	Analog input 13
	VADCG1.5			VADC analog input channel 5 of group 1
AB11	AN14	I	D / HighZ / VDDM	Analog input 14
	VADCG1.6			VADC analog input channel 6 of group 1
AA11	AN15	I	D / HighZ / VDDM	Analog input 15
	VADCG1.7			VADC analog input channel 7 of group 1

Package and Pinning Definitions TC299x Pin Definition and Functions:
Table 2-23 Analog Inputs (cont'd)

Pin	Symbol	Ctrl	Type	Function
AD10	AN16	I	D / HighZ / VDDM	Analog input 16
	VADCG2.0			VADC analog input channel 0 of group 2
AB10	AN17	I	D / HighZ / VDDM	Analog input 17
	VADCG2.1			VADC analog input channel 1 of group 2
AD9	AN18	I	D / HighZ / VDDM	Analog input 18
	VADCG2.2			VADC analog input channel 2 of group 2
AD8	AN19	I	D / HighZ / VDDM	Analog input 19
	VADCG2.3			VADC analog input channel 3 of group 2 (with pull down diagnostics)
AE8	AN20	I	D / HighZ / VDDM	Analog input 20
	VADCG2.4			VADC analog input channel 4 of group 2
	DS2PA			DSADC: positive analog input of channel 2, pin A
AE7	AN21	I	D / HighZ / VDDM	Analog input 21
	VADCG2.5			VADC analog input channel 5 of group 2
	DS2NA			DSADC: negative analog input channel 2, pin A
AA10	AN22	I	D / HighZ / VDDM	Analog input 22
	VADCG2.6			VADC analog input channel 6 of group 2
Y10	AN23	I	D / HighZ / VDDM	Analog input 23
	VADCG2.7			VADC analog input channel 7 of group 2
AD7	AN24	I	S / HighZ / VDDM	Analog input 24
	VADCG3.0			VADC analog input channel 0 of group 3
	DS2PB			DSADC: positive analog input of channel 2, pin B
	SENT0A			SENT input channel 0, pin A
AD6	AN25	I	S / HighZ / VDDM	Analog input 24
	VADCG3.1			VADC analog input channel 1 of group 3 (with pull down diagnostics)
	DS2NB			DSADC: negative analog input channel 2, pin B
	SENT1A			SENT input channel 1, pin A
AC7	AN26	I	S / HighZ / VDDM	Analog input 26
	VADCG3.2			VADC analog input channel 2 of group 3 (with pull down diagnostics)
	SENT2A			SENT input channel 2, pin A
AC6	AN27	I	S / HighZ / VDDM	Analog input 27
	VADCG3.3			VADC analog input channel 3 of group 3 (with pull down diagnostics)
	SENT3A			SENT input channel 3, pin A
AB7	AN28	I	D / HighZ / VDDM	Analog input 28
	VADCG3.4			VADC analog input channel 4 of group 3 (with pull down diagnostics)

Package and Pinning Definitions TC299x Pin Definition and Functions:
Table 2-23 Analog Inputs (cont'd)

Pin	Symbol	Ctrl	Type	Function
AB6	AN29	I	D / HighZ / VDDM	Analog input 29
	VADCG3.5			VADC analog input channel 5 of group 3 (with pull down diagnostics)
AA9	AN30	I	D / HighZ / VDDM	Analog input 30
	VADCG3.6			VADC analog input channel 6 of group 3
Y9	AN31	I	D / HighZ / VDDM	Analog input 31
	VADCG3.7			VADC analog input channel 7 of group 3
W9	AN32	I	S / HighZ / VDDM	Analog input 32
	VADCG4.0			VADC analog input channel 0 of group 4
	SENT4A			SENT input channel 4, pin A
Y6	AN33	I	S / HighZ / VDDM	Analog input 33
	VADCG4.1			VADC analog input channel 1 of group 4
	SENT5A			SENT input channel 5, pin A
W10	AN34	I	D / HighZ / VDDM	Analog input 34
	VADCG4.2			VADC analog input channel 2 of group 4
Y7	AN35	I	D / HighZ / VDDM	Analog input 35
	VADCG4.3			VADC analog input channel 3 of group 4 (with pull down diagnostics)
V9	AN36	I	S / HighZ / VDDM	Analog input 34
	VADCG4.4			VADC analog input channel 4 of group 4
	DS3PA			DSADC: positive analog input of channel 3, pin A
	SENT6A			SENT input channel 6, pin A
W7	AN37	I	S / HighZ / VDDM	Analog input 37
	VADCG4.5			VADC analog input channel 5 of group 4
	DS3NA			DSADC: negative analog input channel 3, pin A
	SENT7A			SENT input channel 7, pin A
V10	AN38	I	S / HighZ / VDDM	Analog input 38
	VADCG4.6			VADC analog input channel 6 of group 4
	DS3PB			DSADC: positive analog input of channel 3, pin B
	SENT8A			SENT input channel 8, pin A
W6	AN39	I	S / HighZ / VDDM	Analog input 39
	VADCG4.7			VADC analog input channel 7 of group 4
	DS3NB			DSADC: negative analog input channel 3, pin B
	SENT9A			SENT input channel 9, pin A
U10	AN40	I	D / HighZ / VDDM	Analog input 40
	VADCG5.0			VADC analog input channel 0 of group 5
U9	AN41	I	D / HighZ / VDDM	Analog input 41
	VADCG5.1			VADC analog input channel 1 of group 5

Package and Pinning Definitions TC299x Pin Definition and Functions:
Table 2-23 Analog Inputs (cont'd)

Pin	Symbol	Ctrl	Type	Function
T10	AN42	I	D / HighZ / VDDM	Analog input 42
	VADCG5.2			VADC analog input channel 2 of group 5
T9	AN43	I	D / HighZ / VDDM	Analog input 43
	VADCG5.3			VADC analog input channel 3 of group 5 (with pull down diagnostics)
V6	AN44	I	D / HighZ / VDDM	Analog input 44
	VADCG5.4			VADC analog input channel 4 of group 5
	DS3PC			DSADC: positive analog input of channel 3, pin C
V7	AN45	I	D / HighZ / VDDM	Analog input 45
	VADCG5.5			VADC analog input channel 5 of group 5
	DS3NC			DSADC: negative analog input channel 3, pin C
U6	AN46	I	D / HighZ / VDDM	Analog input 46
	VADCG5.6			VADC analog input channel 6 of group 5
	DS3PD			DSADC: positive analog input of channel 3, pin D
U7	AN47	I	D / HighZ / VDDM	Analog input 47
	VADCG5.7			VADC analog input channel 7 of group 5
	DS3ND			DSADC: negative analog input channel 3, pin D
AK7	AN48	I	D / HighZ / VDDM	Analog input 48
	VADCG8.0			VADC analog input channel 0 of group 8
AJ7	AN49	I	D / HighZ / VDDM	Analog input 49
	VADCG8.1			VADC analog input channel 1 of group 8 (muxttest)
AJ6	AN50	I	D / HighZ / VDDM	Analog input 50
	VADCG8.2			VADC analog input channel 2 of group 8 (muxttest)
AK6	AN51	I	D / HighZ / VDDM	Analog input 51
	VADCG8.3			VADC analog input channel 3 of group 8
AJ5	AN52	I	D / HighZ / VDDM	Analog input 52
	VADCG8.4			VADC analog input channel 4 of group 8
	DS6PA			DSADC: positive analog input of channel 6, pin A
AK5	AN53	I	D / HighZ / VDDM	Analog input 53
	VADCG8.5			VADC analog input channel 5 of group 8
	DS6NA			DSADC: negative analog input channel 6, pin A
AJ4	AN54	I	D / HighZ / VDDM	Analog input 5
	VADCG8.6			VADC analog input channel 6 of group 8
	DS6PB			DSADC: positive analog input of channel 6, pin B
AK4	AN55	I	D / HighZ / VDDM	Analog input 50
	VADCG8.7			VADC analog input channel 7 of group 8
	DS6NB			DSADC: negative analog input channel 6, pin B
AF1	AN56	I	D / HighZ / VDDM	Analog input 56
	VADCG9.0			VADC analog input channel 0 of group 9

Package and Pinning Definitions TC299x Pin Definition and Functions:
Table 2-23 Analog Inputs (cont'd)

Pin	Symbol	Ctrl	Type	Function
AF2	AN57	I	D / HighZ / VDDM	Analog input 57
	VADCG9.1			VADC analog input channel 1 of group 9 (muxtest)
AE2	AN58	I	D / HighZ / VDDM	Analog input 58
	VADCG9.2			VADC analog input channel 2 of group 9 (muxtest)
AE1	AN59	I	D / HighZ / VDDM	Analog input 59
	VADCG9.3			VADC analog input channel 3 of group 9
AD1	AN60	I	D / HighZ / VDDM	Analog input 60
	VADCG9.4			VADC analog input channel 4 of group 9
	DS7PA			DSADC: positive analog input of channel 7, pin A
AD2	AN61	I	D / HighZ / VDDM	Analog input 61
	VADCG9.5			VADC analog input channel 5 of group 9
	DS7NA			DSADC: negative analog input channel 7, pin A
AC2	AN62	I	D / HighZ / VDDM	Analog input 62
	VADCG9.6			VADC analog input channel 6 of group 9
	DS7PB			DSADC: positive analog input of channel 7, pin B
AC1	AN63	I	D / HighZ / VDDM	Analog input 63
	VADCG9.7			VADC analog input channel 7 of group 9
	DS7NB			DSADC: negative analog input channel 7, pin B
AB2	AN64	I	D / HighZ / VDDM	Analog input 64
	VADCG10.0			VADC analog input channel 0 of group 10
AB1	AN65	I	D / HighZ / VDDM	Analog input 65
	VADCG10.1			VADC analog input channel 1 of group 10 (muxtest)
AA2	AN66	I	D / HighZ / VDDM	Analog input 66
	VADCG10.2			VADC analog input channel 2 of group 10 (muxtest)
	DS8PB			DSADC: positive analog input of channel 8, pin B
AA1	AN67	I	S / HighZ / VDDM	Analog input 67
	VADCG10.3			VADC analog input channel 3 of group 10
	DS8NB			DSADC: negative analog input channel 8, pin B
	SENT10A			SENT input channel 10, pin A
Y1	AN68	I	S / HighZ / VDDM	Analog input 68
	VADCG10.4			VADC analog input channel 4 of group 10
	DS8PA			DSADC: positive analog input of channel 8, pin A
	SENT11A			SENT input channel 11, pin A
Y2	AN69	I	S / HighZ / VDDM	Analog input 69
	VADCG10.5			VADC analog input channel 5 of group 10
	DS8NA			DSADC: negative analog input channel 8, pin A
	SENT12A			SENT input channel 12, pin A

Package and Pinning Definitions TC299x Pin Definition and Functions:
Table 2-23 Analog Inputs (cont'd)

Pin	Symbol	Ctrl	Type	Function
W1	AN70	I	S / HighZ / VDDM	Analog input 70
	VADCG10.6			VADC analog input channel 6 of group 10
	DS9PA			DSADC: positive analog input of channel 9, pin A
	SENT13A			SENT input channel 13, pin A
W2	AN71	I	S / HighZ / VDDM	Analog input 71
	VADCG10.7			VADC analog input channel 7 of group 10
	DS9NA			DSADC: negative analog input channel 9, pin A
	SENT14A			SENT input channel 14, pin A

Table 2-24 System I/O

Pin	Symbol	Ctrl	Type	Function
M22	$\overline{\text{PORST}}$	I	PORST / PD / VEXT	Power On Reset Input Additional strong PD in case of power fail.
L21	$\overline{\text{ESR0}}$	I/O	MP / OD / VEXT	External System Request Reset 0 Default configuration during and after reset is open-drain driver. The driver drives low during power-on reset. This is valid additionally after deactivation of PORST until the internal reset phase has finished. See also SCU chapter for details. Default after power-on can be different. See also SCU chapter 'Reset Control Unit' and SCU_IOCR register description.
	EVRWUP	I		EVR Wakeup Pin
M21	$\overline{\text{ESR1}}$	I/O	MP / PU1 / VEXT	External System Request Reset 1 Default NMI function. See also SCU chapter 'Reset Control Unit' and SCU_IOCR register description.
	EVRWUP	I		EVR Wakeup Pin
AD22	VGATE1P	O	VGATE1P / - / VEXT	External Pass Device gate control for EVR13
AJ20	VGATE3P	O	VGATE3P / - / VEXT	External Pass Device gate control for EVR33
R21	TMS	I	A2 / PD / VDDP3	JTAG Module State Machine Control Input
	DAP1	I/O		Device Access Port Line 1
T24	$\overline{\text{TRST}}$	I	A2 / PD / VDDP3	JTAG Module Reset/Enable Input

Package and Pinning Definitions TC299x Pin Definition and Functions:
Table 2-24 System I/O (cont'd)

Pin	Symbol	Ctrl	Type	Function
P21	TCK	I	A2 / PD / VDDP3	JTAG Module Clock Input
	DAP0	I		Device Access Port Line 0
U25	XTAL1	I	XTAL1 / - / VDDP3	Main Oscillator/PLL/Clock Generator Input
U24	XTAL2	O	XTAL2 / - / VDDP3	Main Oscillator/PLL/Clock Generator Output

Table 2-25 Supply

Pin	Symbol	Ctrl	Type	Function
AE11	VAREF1	I	Vx	Positive Analog Reference Voltage 1
AE12	VAGND1	I	Vx	Negative Analog Reference Voltage 1
AA6	VAREF2	I	Vx	Positive Analog Reference Voltage 2
AA7	VAGND2	I	Vx	Negative Analog Reference Voltage 2
AE10, AJ9, AK9	VDDM	I	Vx	ADC Analog Power Supply (3.3V / 5V)
N12, M13	VDD / VDDSB	I	Vx	Emulation Device: Emulation SRAM Standby Power Supply (1.3V) (Emulation Device only). Production Device: VDD (1.3V).
M18, N19, V12, V19, W13, W18	VDD	I	Vx	Digital Core Power Supply (1.3V)
V24	VDD	I	Vx	Digital Core Power Supply (1.3V). The supply pin inturn supplies the main XTAL Oscillator/PLL (1.3V) . A higher decoupling capacitor is therefore recommended to the VSS pin for better noise immunity.
A2, B3, F7, G8, AC24, AD25, AH29, AJ30	VEXT	I	Vx	External Power Supply (5V / 3.3V)
A29, B28, F24, G23	VDDP3	I	Vx	Digital Power Supply for Flash (3.3V). Can be also used as external 3.3V Power Supply for VFLEX.
V25	VDDP3	I	Vx	Digital Power Supply for Oscillator, LVDSH and A2 pads (3.3V). The supply pin inturn supplies the main XTAL Oscillator/PLL (3.3V) . A higher decoupling capacitor is therefore recommended to the VSS pin for better noise immunity.
K20, J21	VDDFL3	I	Vx	Flash Power Supply (3.3V)
J10	VFLEX	I	Vx	Digital Power Supply for Flex Port Pads (5V / 3.3V)

Package and Pinning Definitions TC299x Pin Definition and Functions:
Table 2-25 Supply (cont'd)

Pin	Symbol	Ctrl	Type	Function
AJ11, AK11, AK20, AK29	VFLEXE	I	Vx	Digital Power Supply for EBU Flex Port Pads (5V / 3.3V)
J29, J30, AH30	VEBU	I	Vx	Digital Power Supply for EBU (3.3V)
AK8, AJ8, AE9	VSSM	I	Vx	Analog Ground for VDDM
AA16	VEVRSB	I	Vx	Standby Power Supply (3.3V/5V) for the Standby SRAM (CPU0.DSPR). If Standby mode is not used: To be handled like VEXT (3.3V/5V).
A30, B2, B29, B30, F25, G7, G24, H29, H30, J9, J22, K10, K21, T25, AA21, AB22, AD24, AE25, AJ10, AJ29, AK10, AK30	VSS	I	Vx	Digital Ground (outer balls)
W14, W17, V14, V15, V16, V17	VSS	I	Vx	Digital Ground (center balls)
U12, U13, U15, U16, U18, U19	VSS	I	Vx	Digital Ground (center balls)
T13, T14, T15, T16, T17, T18	VSS	I	Vx	Digital Ground (center balls)
R13, R14, R15, R16, R17, R18	VSS	I	Vx	Digital Ground (center balls)
P12, P13, P15, P16, P18, P19	VSS	I	Vx	Digital Ground (center balls)
M14, M15, M16, M17, N14, N15, N16, N17	VSS	I	Vx	Digital Ground (center balls)
W15	VSS	I	Vx	Digital Ground (center balls) This ball is used in the Emulation Device as AGBT TX0N
W16	VSS	I	Vx	Digital Ground (center balls) This ball is used in the Emulation Device as AGBT TX0P
T12	VSS	I	Vx	Digital Ground (center balls) This ball is used in the Emulation Device as AGBT CLKN
R12	VSS	I	Vx	Digital Ground (center balls) This ball is used in the Emulation Device as AGBT CLKP
T19	VSS	I	Vx	Digital Ground (center balls) This ball is used in the Emulation Device as AGBT ERR

Package and Pinning Definitions TC299x Pin Definition and Functions:

Table 2-25 Supply (cont'd)

Pin	Symbol	Ctrl	Type	Function
AK2, AK3, AJ1, AJ2, AJ3, AH1, AH2, AG1, AG2, W30, V1, V2, V29, V30, T1, R1, R2, J1, H1, H2, G29, G30, F29, F30, E1, E2, E29, E30, D1, D2, D29, D30, C1, C2, C29, C30 B1, B4, B6, B9, B10, B14, B17, B20, B21, B25, B26, B27, A3, A4, A8, A9, A10, A17, A21, A25, A26, A27, A28	NC	I	NC	Not Connected. These pins are reserved for future extensions and shall not be connected externally.
R19	NC / VDDPSB	I	NCVDD PSB	Emulation Device: Power Supply (3.3V) for DAP/JTAG pad group. Can be connected to VDDP or can be left unsupplied (see document 'AurixED' / Aurix Emulation Devices specification). Production Device: This pin is not connected on package level. It can be connected on PCB level to VDDP or Ground or can be left unsupplied.
A1, F6, AK1, AE6, AB9	NC	I	NC1	Not Connected. These pins are not connected on package level and will not be used for future extensions.

Legend:

Column "Ctrl.":

 I = Input (for GPIO port Lines with IOCR bit field Selection PCx = 0XXX_B)

O = Output

 O0 = Output with IOCR bit field selection PCx = 1X000_B

 O1 = Output with IOCR bit field selection PCx = 1X001_B (ALT1)

 O2 = Output with IOCR bit field selection PCx = 1X010_B (ALT2)

 O3 = Output with IOCR bit field selection PCx = 1X011_B (ALT3)

 O4 = Output with IOCR bit field selection PCx = 1X100_B (ALT4)

 O5 = Output with IOCR bit field selection PCx = 1X101_B (ALT5)

 O6 = Output with IOCR bit field selection PCx = 1X110_B (ALT6)

 O7 = Output with IOCR bit field selection PCx = 1X111_B (ALT7)

Column "Type":

LP = Pad class LP (5V/3.3V, Class LP parameters for digital input / output and class D parameters for analog input function)

MP = Pad class MP (5V/3.3V)

MP+ = Pad class MP+ (5V/3.3V)

MPR = Pad class MPR (5V/3.3V)

A2 = Pad class A2 (3.3V)

Package and Pinning Definitions TC299x Pin Definition and Functions:

LVDSM = Pad class LVDSM (5V/3.3V)

LVDSH = Pad class LVDSH (3.3V)

S = Pad class S (Class S parameters for digital input and class D parameters for analog input function)

D = Pad class D (VADC / DSADC)

PU = with pull-up device connected during reset ($\overline{\text{PORST}} = 0$)

PU1 = with pull-up device connected during reset ($\overline{\text{PORST}} = 0$)^{1) 2) 3)}

PD = with pull-down device connected during reset ($\overline{\text{PORST}} = 0$)

PD1 = with pull-down device connected during reset ($\overline{\text{PORST}} = 0$)^{1) 2) 3)}

PX = Behavior depends on usage: PD in EVR13 SMPS Mode and PU1 in GPIO Mode

OD = open drain during reset ($\overline{\text{PORST}} = 0$)

HighZ = tri-state during reset ($\overline{\text{PORST}} = 0$)

PORST = PORST input pad

XTAL1 = XTAL1 input pad

XTAL2 = XTAL2 input pad

VGATE1P = VGATE1P

VGATE3P = VGATE3P

Vx = Supply

NC = These pins are reserved for future extensions and shall not be connected externally

NC1 = These pins are not connected on package level and will not be used for future extensions

NCVDDPSB = This pin has a different functionality in an Production Device and an Emulation Device. For details pls. see Pin/Ball description of this pin.

NCVDDSB = This pin has a different functionality in an Production Device and an Emulation Device. For details pls. see Pin/Ball description of this pin.

2.1.2 Emergency Stop Function

The Emergency Stop function can be used to force GPIOs (General Purpose Inputs/Outputs) via an external input signal (EMGSTOPA or EMGSTOPB) into a defined state:

- Input state and
- PU or High-Z depending on HWCFG[6] level latched during Porst active

Control of the Emergency Stop function:

- The Emergency Stop function can be enabled/disabled in the SCU (see chapter "SCU", "Emergency Stop Control")
- The Emergency Stop input signal, EMGSTOPA (P33.8) / EMGSTOPB (P21.2), can be selected in the SCU (see chapter "SCU", "Emergency Stop Control")
- On port level, each GPIO can be enabled/disabled for the Emergency Stop function via the Px_ESR (Port x Emergency Stop) registers in the port control logic (see chapter "General Purpose I/O Ports and Peripheral I/O Lines", "Emergency Stop Register").

The Emergency Stop function is available for all GPIO Ports with the following exceptions:

- Not available for P20.2 (General Purpose Input/GPI only, overlaid with Testmode)
- Not available for P40.x (analog input ANx overlaid with GPI)
- Not available for P32.0 EVR13 SMPS mode.

1) The default state of GPIOs (Px.y) during and after PORST active is controlled via HWCFG[6] (P14.4). HWCFG[6] has a weak internal pull-up active at start-up if the pin is left unconnected. See also User's Manual, "Introduction Chapter", "General Purpose I/O Ports and Peripheral I/O Lines", Figure: "Default state of port pins during and after reset".

2) If HWCFG[6] is left unconnected or is externally pulled high, weak internal pull-ups (PU1) / pull-downs (PD1) are active during and after reset.

3) If HWCFG[6] is connected to ground, the PD1 / PU1 pins are predominantly in HighZ during and after reset.

Package and Pinning Definitions TC299x Pin Definition and Functions:

- Not available for dedicated I/O without General Purpose Output function (e.g ESRx, TMS, TCK)

The Emergency Stop function can be overruled on the following GPIO Ports:

- P00.x and P02.x: Emergency Stop can be overruled by the 8-Bit Standby Controller (SBR), if implemented. Overruling can be disabled via the control registers P00_SCR / P02_SCR (see chapter “General Purpose I/O Ports and Peripheral I/O Lines”, P00 / P01)
- P00.x: Emergency Stop can be overruled by the VADC. Overruling can be disabled via the control register P00_SCR (see chapter “General Purpose I/O Ports and Peripheral I/O Lines”, P00)
- P14.0 and P14.1: Emergency Stop can be overruled in the DXCPL mode (DAP over can physical layer mode). No Overruling in the DXCM (Debug over can message) mode
- P21.6: Emergency Stop can be overruled in JTAG mode if this pin is used as TDI
- P21.7: Emergency Stop can be overruled in JTAG or Three Pin DAP mode
- P20.0: Emergency Stop can be overruled in JTAG mode if this GPIO is used as TDI
- P33.8: Emergency Stop can be overruled if this pin is used as safety output pin (SMUFSP)

2.1.3 Pull-Up/Pull-Down Reset Behavior of the Pins

Table 2-26 List of Pull-Up/Pull-Down Reset Behavior of the Pins

Pins	PORST = 0	PORST = 1
all GPIOs	Pull-up if HWCFG[6] = 1 or High-Z if HWCFG[6] = 0	
$\overline{\text{TDI}}$, $\overline{\text{TESTMODE}}$	Pull-up	
$\overline{\text{PORST}}^{1)}$	Pull-down with I_{PORST} relevant	Pull-down with I_{PDLI} relevant
$\overline{\text{TRST}}$, TCK, TMS	Pull-down	
ESR0	The open-drain driver is used to drive low. ²⁾	Pull-up ³⁾
ESR1	Pull-up ³⁾	
TDO	Pull-up	High-Z/Pull-up ⁴⁾

1) Pull-down with I_{PORST} relevant is always activated when a primary supply monitor detects a violation.

2) Valid additionally after deactivation of PORST until the internal reset phase has finished. See the SCU chapter for details.

3) See the SCU_IOCRR register description.

4) Depends on JTAG/DAP selection with $\overline{\text{TRST}}$.

In case of leakage test ($\overline{\text{PORST}} = 0$ and $\overline{\text{TESTMODE}} = 0$), the pull-down of the $\overline{\text{TRST}}$ pin is switched off. In case of an user application ($\overline{\text{TESTMODE}} = 1$), the pull-down of the $\overline{\text{TRST}}$ is always switched on.

Package and Pinning Definitions TC298x Pin Definition and Functions:

2.2 TC298x Pin Definition and Functions: BGA416

Figure 2-2 is showing the TC298x Logic Symbol for the package variant: BGA416.

	1	2	3	4	5	6	7	8	9	10	11	12	13	14	15	16	17	18	19	20	21	22	23	24	25	26	
A	NC	P10.15	P10.11	P10.8	P11.3	P10.5	P10.2	P10.4	P10.0	P11.7	P12.0	P13.14	P13.10	P14.8	P14.12	P13.6	P13.5	VDDFL3	P14.11	P15.7	P15.4	ESR1	ESF0	P20.0	VEXT	VSS	A
B	P02.1	P02.0	P10.13	P10.7	P11.9	P10.9	P10.3	P10.1	P11.13	P11.5	P12.1	P13.12	P13.11	P14.15	P14.14	P13.7	P13.4	VDDFL3	P14.13	P15.6	P15.2	FORST	P20.2	VEXT	VSS	VDD	B
C	P02.4	P02.11	P10.14	P10.10	P11.12	P11.6	P11.15	P11.14	P11.8	P11.4	P11.1	P13.9	P14.6	P14.3	P14.10	P13.3	P13.0	P13.1	P14.9	P14.5	P14.0	P15.1	VEXT	VSS	VDD	P21.5	C
D	P02.13	P02.15	P02.12	P02.5	P11.10	P11.11	VLEX	VSS	VDD	P11.2	P11.0	P14.7	P14.4	VEXT	VSS	P15.8	P13.2	P15.3	P15.5	P14.2	P14.1	VEXT	VSS	VDD	P21.7	P21.4	D
E	P02.14	P02.2	F01.7	F02.9	E	6	7	8	9	10	11	12	13	14	15	16	17	18	19	20	21	E	VDD	TCK	P21.6	VDDP3	E
F	F01.0	F02.3	F01.6	F02.10	F																	F	TRST	TMS	VSS	VDD	F
G	F01.2	P10.6	F01.4	F01.5	G																	G	P21.3	P21.1	XTA2	XTA1	G
H	P02.7	P02.6	F01.3	VDD	H																	H	P21.2	VDDP3	VDDP3	VDDP3	H
J	F01.9	F01.1	F02.8	VSS	J																	J	P21.0	P22.1	P22.2	P22.3	J
K	F01.11	F01.10	F01.8	VEXT	K																	K	P22.0	P23.4	P23.5	P23.6	K
L	F01.15	F01.14	F01.13	F01.12	L																	L	VSS	P23.1	P23.2	P23.3	L
M	F00.3	F00.2	F00.1	F00.0	M																	M	VEBU	P24.14	P24.15	P23.0	M
N	F00.10	F00.9	F00.5	F00.4	N																	N	P24.10	P24.11	P24.12	P24.13	N
P	F00.12	F00.11	F00.13	F00.15	P																	P	VDD	P24.7	P24.8	P24.9	P
R	NC/ VDDSB	F00.14	F00.6	NC/ VDDSB	R																	R	VSS	P24.4	P24.5	P24.6	R
T	A#2	F00.8	F00.7	VSS	T																	T	VEBU	P24.1	P24.2	P24.3	T
U	A#3	A#0	A#1	A#0	U																	U	P24.0	P25.13	P25.14	P25.15	U
V	A#7	A#6	A#7	A#6	V																	V	VDD	P25.10	P25.11	P25.12	V
W	A#9	A#4	A#2	VAREF2	W																	W	VSS	P25.7	P25.8	P25.9	W
Y	A#5	A#0	A#3	VQND2	Y																	Y	VEBU	P25.3	P25.4	P25.5	Y
AA	A#1	A#6	A#5	A#6	AA																	AA	P25.2	P25.1	P26.0	P25.0	AA
AB	A#8	A#7	A#7	A#7	AB	6	7	8	9	10	11	12	13	14	15	16	17	18	19	20	21	AB	VDD	P30.2	P30.7	P30.12	AB
AC	A#9	A#4	A#16	A#8	A#0	VQND1	A#4	A#0	P34.1	P34.2	P33.0	P33.4	P33.14	P32.4	P33.7	VEXT	VGATEIP	VLEDE	VSS	VDD	VGATEIP	VLEDE	VSS	P30.3	P30.8	P30.13	AC
AD	A#6	A#8	A#17	A#9	A#1	VAREF1	A#5	A#1	VLEFSB	P34.4	P33.1	P33.5	P33.15	P32.5	P33.8	VEXT	P32.0	P31.0	P31.3	P31.6	P31.9	P31.12	P31.14	P30.4	P30.9	P30.14	AD
AE	A#9	A#18	A#10	A#2	VDDM	A#2	A#4	A#2	VDDM	P34.5	P33.2	P33.6	P32.2	P33.10	P33.13	VEXT	P32.6	P31.1	P31.4	P31.7	P31.10	P31.13	P31.15	P30.5	P30.10	P30.15	AE
AF	NC	A#19	A#11	A#8	VSSM	A#3	A#5	A#3	VSSM	P34.3	P33.3	P33.9	P32.3	P33.11	P33.12	VEXT	P32.7	P31.2	P31.5	P31.8	P31.11	P30.0	P30.1	P30.6	P30.11	NC	AF
	1	2	3	4	5	6	7	8	9	10	11	12	13	14	15	16	17	18	19	20	21	22	23	24	25	26	

Top-View

	10	11	12	13	14	15	16	17	
K	VSS	VSS	VSS	VSS	VSS	VSS	VSS	VSS	K
L	VSS	VSS	VSS	VSS	VSS	VSS	VSS	VSS	L
M	VSS	VSS	VSS	VSS	VSS	VSS	VSS	VSS	M
N	VSS	VSS	VSS	VSS	VSS	VSS	VSS	VSS	N
P	VSS (ACBT CLKP)	VSS	VSS	VSS	VSS	VSS	VSS	NC (VDDP3)	P
R	VSS (ACBT CLKN)	VSS	VSS	VSS	VSS	VSS	VSS	VSS (ACBT EPR)	R
T	VSS	VSS	VSS	VSS	VSS	VSS	VSS	VSS	T
U	VSS	VSS	VSS (ACBT TXDN)	VSS (ACBT TXDP)	VSS	VSS	VSS	VSS	U

Figure 2-2 TC298x Logic Symbol for the package variant BGA416.

2.2.1 TC298x BGA416 Package Variant Pin Configuration

Table 2-27 Port 00 Functions

Pin	Symbol	Ctrl	Type	Function
M4	P00.0	I	MP / PU1 / VEXT	General-purpose input
	TIN9			GTM input
	CTRAPA			CCU61 input
	T12HRE			CCU60 input
	INJ00			MSC0 input
	CIFD9			CIF input
	P00.0			O0
	TOUT9	O1		GTM output
	ASCLK3	O2		ASCLIN3 output
	ATX3	O3		ASCLIN3 output
	–	O4		Reserved
	TXDCAN1	O5		CAN node 1 output
	–	O6		Reserved
	COU63	O7		CCU60 output
	ETHMDIOA	HWOUT		ETH input/output

Package and Pinning Definitions TC298x Pin Definition and Functions:
Table 2-27 Port 00 Functions (cont'd)

Pin	Symbol	Ctrl	Type	Function
M3	P00.1	I	LP / PU1 / VEXT	General-purpose input
	TIN10			GTM input
	ARX3E			ASCLIN3 input
	RXDCAN1D			CAN node 1 input
	PSIRX0A			PSI5 input
	SENT0B			SENT input
	CC60INB			CCU60 input
	CC60INA			CCU61 input
	DSCIN5A			DSADC channel 5 input
	DS5NA			DSADC positive analog input of channel channel 5, pin A
	DSCIN7B			DSADC channel 7 input
	VADCG7.5			VADC analog input channel 5 of group 7
	CIFD10			CIF input
	P00.1			O0
	TOUT10	O1	GTM output	
	ATX3	O2	ASCLIN3 output	
	-	O3	Reserved	
	DSCOUT5	O4	DSADC channel 5 output	
	DSCOUT7	O5	DSADC channel 7 output	
	SPC0	O6	SENT output	
CC60	O7	CCU61 output		
M2	P00.2	I	LP / PU1 / VEXT	General-purpose input
	TIN11			GTM input
	SENT1B			SENT input
	DSDIN5A			DSADC channel 5 input
	DSDIN7B			DSADC channel 7 input
	DS5PA			DSADC negative analog input of channel 5, pin A
	VADCG7.4			VADC analog input channel 4 of group 7
	CIFD11			CIF input
	P00.2			O0
	TOUT11	O1	GTM output	
	ASCLK3	O2	ASCLIN3 output	
	TXDCANr1	O3	CAN node 1 output (MultiCANr+)	
	PSITX0	O4	PSI5 output	
	TXDCAN3	O5	CAN node 3 output	
	SLSO34	O6	QSPI3 output	
	COUT60	O7	CCU61 output	

Package and Pinning Definitions TC298x Pin Definition and Functions:

Table 2-27 Port 00 Functions (cont'd)

Pin	Symbol	Ctrl	Type	Function	
M1	P00.3	I	LP / PU1 / VEXT	General-purpose input	
	TIN12			GTM input	
	RXDCAN3A			CAN node 3 input	
	RXDCANr1A			CAN node 1 input (MultiCANr+)	
	PSIRX1A			PSI5 input	
	PSISRXA			PSI5-S input	
	SENT2B			SENT input	
	CC61INB			CCU60 input	
	CC61INA			CCU61 input	
	DSCIN3A			DSADC channel 3 input	
	VADCG7.3			VADC analog input channel 3 of group 7	
	DSITR5F			DSADC channel 5 input	
	CIFD12			CIF input	
	P00.3	O0	General-purpose output		
	TOUT12	O1	GTM output		
	ASLSO3	O2	ASCLIN3 output		
	–	O3	Reserved		
	DSCOUT3	O4	DSADC channel 3 output		
	–	O5	Reserved		
	SPC2	O6	SENT output		
CC61	O7	CCU61 output			
N4	P00.4	I	LP / PU1 / VEXT	General-purpose input	
	TIN13			GTM input	
	REQ7			SCU input	
	SENT3B			SENT input	
	DSDIN3A			DSADC channel 3 input	
	DSSGNA			DSADC channel input	
	VADCG7.2			VADC analog input channel 2 of group 7	
	CIFD13			CIF input	
	P00.4			O0	General-purpose output
	TOUT13			O1	GTM output
	PSISTX			O2	PSI5-S output
	–			O3	Reserved
	PSITX1			O4	PSI5 output
	VADCG4BFL0	O5	VADC output		
	SPC3	O6	SENT output		
	COUT61	O7	CCU61 output		

Package and Pinning Definitions TC298x Pin Definition and Functions:
Table 2-27 Port 00 Functions (cont'd)

Pin	Symbol	Ctrl	Type	Function	
N3	P00.5	I	LP / PU1 / VEXT	General-purpose input	
	TIN14			GTM input	
	PSIRX2A			PSI5 input	
	SENT4B			SENT input	
	CC62INB			CCU60 input	
	CC62INA			CCU61 input	
	DSCIN2A			DSADC channel 2 input	
	VADCG7.1			VADC analog input channel 1 of group 7	
	CIFD14			CIF input	
	P00.5	O0		General-purpose output	
	TOUT14	O1		GTM output	
	DSCGPWMN	O2		DSADC output	
	SLSO33	O3		QSPI3 output	
	DSCOUT2	O4		DSADC channel 2 output	
	VADCG4BFL1	O5		VADC output	
	SPC4	O6		SENT output	
	CC62	O7		CCU61 output	
R3	P00.6	I	LP / PU1 / VEXT	General-purpose input	
	TIN15			GTM input	
	SENT5B			SENT input	
	DSDIN2A			DSADC channel 2 input A	
	VADCG7.0			VADC analog input channel 0 of group 7 (with pull down diagnostics)	
	DSITR4F			DSADC channel 4 input F	
	CIFD15			CIF input	
	P00.6			O0	General-purpose output
	TOUT15			O1	GTM output
	DSCGPWMP	O2		DSADC output	
	VADCG4BFL2	O3		VADC output	
	PSITX2	O4		PSI5 output	
	VADCEMUX10	O5		VADC output	
	SPC5	O6		SENT output	
	COOUT62	O7		CCU61 output	

Package and Pinning Definitions TC298x Pin Definition and Functions:
Table 2-27 Port 00 Functions (cont'd)

Pin	Symbol	Ctrl	Type	Function	
T3	P00.7	I	LP / PU1 / VEXT	General-purpose input	
	TIN16			GTM input	
	SENT6B			SENT input	
	CC60INC			CCU61 input	
	CCPOS0A			CCU61 input	
	T12HRB			CCU60 input	
	T2INA			GPT120 input	
	DSCIN4A			DSADC channel 4 input A	
	DS4NA			DSADC negative analog input channel 4, pin A	
	VADCG6.5			VADC analog input channel 5 of group 6	
	CIFCLK			CIF input	
	P00.7			O0	General-purpose output
	TOUT16			O1	GTM output
	–	O2	Reserved		
	VADCG4BFL3	O3	VADC output		
	DSCOUT4	O4	DSADC channel 4 output		
	VADCEMUX11	O5	VADC output		
	SPC6	O6	SENT output		
	CC60	O7	CCU61 output		
T2	P00.8	I	LP / PU1 / VEXT	General-purpose input	
	TIN17			GTM input	
	SENT7B			SENT input	
	CC61INC			CCU61 input	
	CCPOS1A			CCU61 input	
	T13HRB			CCU60 input	
	T2EUDA			GPT120 input	
	DSDIN4A			DSADC channel 4 input A	
	DS4PA			DSADC positive analog input of channel 4, pin A	
	VADCG6.4			VADC analog input channel 4 of group 6	
	CIFVSNC			CIF input	
	P00.8			O0	General-purpose output
	TOUT17			O1	GTM output
	SLSO36	O2	QSPI3 output		
	–	O3	Reserved		
	–	O4	Reserved		
	VADCEMUX12	O5	VADC output		
	SPC7	O6	SENT output		
	CC61	O7	CCU61 output		

Package and Pinning Definitions TC298x Pin Definition and Functions:

Table 2-27 Port 00 Functions (cont'd)

Pin	Symbol	Ctrl	Type	Function
N2	P00.9	I	LP / PU1 / VEXT	General-purpose input
	TIN18			GTM input
	SENT8B			SENT input
	CC62INC			CCU61 input
	CCPOS2A			CCU61 input
	T13HRC			CCU60 input
	T12HRC			CCU60 input
	T4EUDA			GPT120 input
	DSCIN1A			DSADC channel 1 input A
	VADCG6.3			VADC analog input channel 3 of group 6
	DSITR3F			DSADC channel 3 input F
	CIFHSNC			CIF input
	P00.9			O0
	TOUT18	O1		GTM output
	SLSO37	O2		QSPI3 output
	ARTS3	O3		ASCLIN3 output
	DSCOUT1	O4		DSADC channel 1 output
	–	O5		Reserved
	SPC8	O6		SENT output
CC62	O7	CCU61 output		
N1	P00.10	I	LP / PU1 / VEXT	General-purpose input
	TIN19			GTM input
	SENT9B			SENT input
	DSDIN1A			DSADC channel 1 input A
	VADCG6.2			VADC analog input channel 2 of group 6
	P00.10	O0		General-purpose output
	TOUT19	O1		GTM output
	–	O2		Reserved
	–	O3		Reserved
	–	O4		Reserved
	–	O5		Reserved
	SPC9	O6		SENT output
	COU63	O7		CCU61 output

Package and Pinning Definitions TC298x Pin Definition and Functions:

Table 2-27 Port 00 Functions (cont'd)

Pin	Symbol	Ctrl	Type	Function
P2	P00.11	I	LP / PU1 / VEXT	General-purpose input
	TIN20			GTM input
	CTRAPA			CCU60 input
	T12HRE			CCU61 input
	DSCIN0A			DSADC channel 0 input A
	VADCG6.1			VADC analog input channel 1 of group 6
	P00.11			O0
	TOUT20	O1		GTM output
	—	O2		Reserved
	—	O3		Reserved
	DSCOUT0	O4		DSADC channel 0 output
	—	O5		Reserved
	—	O6		Reserved
	—	O7		Reserved
P1	P00.12	I	LP / PU1 / VEXT	General-purpose input
	TIN21			GTM input
	ACTS3A			ASCLIN3 input
	DSDIN0A			DSADC channel 0 input A
	VADCG6.0			VADC analog input channel 0 of group 6
	P00.12	O0		General-purpose output
	TOUT21	O1		GTM output
	—	O2		Reserved
	—	O3		Reserved
	—	O4		Reserved
	—	O5		Reserved
	—	O6		Reserved
	COOUT63	O7		CCU61 output
	P3	P00.13		I
TIN167		GTM input		
DSDIN6A		DSADC channel 6 input A		
P00.13		O0	General-purpose output	
TOUT167		O1	GTM output	
—		O2	Reserved	
—		O3	Reserved	
EXTCLK1		O4	SCU output	
—		O5	Reserved	
—		O6	Reserved	
—		O7	Reserved	

Package and Pinning Definitions TC298x Pin Definition and Functions:

Table 2-27 Port 00 Functions (cont'd)

Pin	Symbol	Ctrl	Type	Function
R2	P00.14	I	LP / PU1 / VEXT	General-purpose input
	TIN166			GTM input
	DSCIN6A			DSADC channel 6 input A
	P00.14	O0		General-purpose output
	TOUT166	O1		GTM output
	—	O2		Reserved
	—	O3		Reserved
	DSCOUT6	O4		DSADC channel 6 output
	—	O5		Reserved
	—	O6		Reserved
	—	O7		Reserved
P4	P00.15	I	MP+ / PU1 / VEXT	General-purpose input
	TIN168			GTM input
	DSITR6F			DSADC channel 6 input F
	P00.15	O0		General-purpose output
	TOUT168	O1		GTM output
	—	O2		Reserved
	—	O3		Reserved
	EXTCLK0	O4		SCU output
	—	O5		Reserved
	—	O6		Reserved
	—	O7		Reserved

Table 2-28 Port 01 Functions

Pin	Symbol	Ctrl	Type	Function
F1	P01.0	I	LP / PU1 / VEXT	General-purpose input
	TIN155			GTM input
	DSITR6E			DSADC channel 6 input E
	RXDCAN3F			CAN node 3 input
	RXDCANr1E			CAN node 1 input (MultiCANr+)
	P01.0	O0		General-purpose output
	TOUT155	O1		GTM output
	—	O2		Reserved
	—	O3		Reserved
	—	O4		Reserved
	—	O5		Reserved
	—	O6		Reserved
	—	O7		Reserved

Package and Pinning Definitions TC298x Pin Definition and Functions:
Table 2-28 Port 01 Functions (cont'd)

Pin	Symbol	Ctrl	Type	Function
J2	P01.1	I	LP / PU1 / VEXT	General-purpose input
	TIN159			GTM input
	DSITR8E			DSADC channel 8 input E
	RXD1A1			ERAY1 input
	SENT10B			SENT input
	P01.1	O0		General-purpose output
	TOUT159	O1		GTM output
	–	O2		Reserved
	–	O3		Reserved
	–	O4		Reserved
	–	O5		Reserved
	–	O6		Reserved
	–	O7		Reserved
G1	P01.2	I	LP / PU1 / VEXT	General-purpose input
	TIN156			GTM input
	DSCIN7A			DSADC channel 7 input A
	P01.2	O0		General-purpose output
	TOUT156	O1		GTM output
	–	O2		Reserved
	TXDCAN3	O3		CAN node 3 output
	–	O4		Reserved
	TXDCANr1	O5		CAN node 1 output (MultiCANr+)
	DSCOUT7	O6		DSADC channel 7 output
	–	O7		Reserved
H3	P01.3	I	LP / PU1 / VEXT	General-purpose input
	TIN111			GTM input
	SLSI3B			QSPI3 input
	DSITR7F			DSADC channel 7 input F
	P01.3	O0		General-purpose output
	TOUT111	O1		GTM output
	–	O2		Reserved
	–	O3		Reserved
	SLSO39	O4		QSPI3 output
	TXDCAN1	O5		CAN node 1 output
	–	O6		Reserved
	–	O7		Reserved

Package and Pinning Definitions TC298x Pin Definition and Functions:

Table 2-28 Port 01 Functions (cont'd)

Pin	Symbol	Ctrl	Type	Function
G3	P01.4	I	LP / PU1 / VEXT	General-purpose input
	TIN112			GTM input
	RXDCAN1C			CAN node 1 input
	DSITR7E			DSADC channel 7 input E
	P01.4	O0		General-purpose output
	TOUT112	O1		GTM output
	–	O2		Reserved
	–	O3		Reserved
	SLSO310	O4		QSPI3 output
	–	O5		Reserved
	–	O6		Reserved
	–	O7		Reserved
G4	P01.5	I	LP / PU1 / VEXT	General-purpose input
	TIN113			GTM input
	MRST3C			QSPI3 input
	DSCIN8A			DSADC channel 8 input A
	P01.5	O0		General-purpose output
	TOUT113	O1		GTM output
	–	O2		Reserved
	–	O3		Reserved
	MRST3	O4		QSPI3 output
	–	O5		Reserved
	DSCOUT8	O6		DSADC channel 8 output
	–	O7		Reserved
F3	P01.6	I	MP / PU1 / VEXT	General-purpose input
	TIN114			GTM input
	MTR3C			QSPI3 input
	DSDIN8A			DSADC channel 8 input A
	P01.6	O0		General-purpose output
	TOUT114	O1		GTM output
	–	O2		Reserved
	–	O3		Reserved
	MTR3	O4		QSPI3 output
	–	O5		Reserved
	–	O6		Reserved
	–	O7		Reserved

Package and Pinning Definitions TC298x Pin Definition and Functions:

Table 2-28 Port 01 Functions (cont'd)

Pin	Symbol	Ctrl	Type	Function
E3	P01.7	I	MP / PU1 / VEXT	General-purpose input
	TIN115			GTM input
	SCLK3C			QSPI3 input
	DSITR8F			DSADC channel 8 input F
	P01.7	O0		General-purpose output
	TOUT115	O1		GTM output
	–	O2		Reserved
	–	O3		Reserved
	SCLK3	O4		QSPI3 output
	–	O5		Reserved
	–	O6		Reserved
	–	O7		Reserved
	K3	P01.8		I
TIN162		GTM input		
DSDIN9A		DSADC channel 9 input A		
SENT12B		SENT input		
ARX0C		ASCLIN0 input		
RXDCAN0F		CAN node 0 input		
RXDCANr0E		CAN node 0 input (MultiCANr+)		
RXD1B1		ERAY1 input		
P01.8		O0	General-purpose output	
TOUT162		O1	GTM output	
–		O2	Reserved	
–		O3	Reserved	
–		O4	Reserved	
–		O5	Reserved	
–		O6	Reserved	
–	O7	Reserved		

Package and Pinning Definitions TC298x Pin Definition and Functions:
Table 2-28 Port 01 Functions (cont'd)

Pin	Symbol	Ctrl	Type	Function
J1	P01.9	I	LP / PU1 / VEXT	General-purpose input
	TIN160			GTM input
	DSCIN9A			DSADC channel 9 input A
	SENT11B			SENT input
	P01.9	O0		General-purpose output
	TOUT160	O1		GTM output
	—	O2		Reserved
	—	O3		Reserved
	—	O4		Reserved
	—	O5		Reserved
	DSCOUT9	O6		DSADC channel 9 output
	—	O7		Reserved
K2	P01.10	I	LP / PU1 / VEXT	General-purpose input
	TIN163			GTM input
	DSITR9F			DSADC channel 9 input F
	SENT13B			SENT input
	P01.10	O0		General-purpose output
	TOUT163	O1		GTM output
	—	O2		Reserved
	—	O3		Reserved
	—	O4		Reserved
	—	O5		Reserved
	—	O6		Reserved
	—	O7		Reserved
K1	P01.11	I	LP / PU1 / VEXT	General-purpose input
	TIN165			GTM input
	DSITR9E			DSADC channel 9 input E
	SENT14B			SENT input
	P01.11	O0		General-purpose output
	TOUT165	O1		GTM output
	—	O2		Reserved
	—	O3		Reserved
	—	O4		Reserved
	—	O5		Reserved
	—	O6		Reserved
	—	O7		Reserved

Package and Pinning Definitions TC298x Pin Definition and Functions:

Table 2-28 Port 01 Functions (cont'd)

Pin	Symbol	Ctrl	Type	Function
L4	P01.12	I	MP+ / PU1 / VEXT	General-purpose input
	TIN158			GTM input
	P01.12	O0		General-purpose output
	TOUT158	O1		GTM output
	—	O2		Reserved
	—	O3		Reserved
	—	O4		Reserved
	—	O5		Reserved
	TXD1A	O6		ERAY1 output
	—	O7		Reserved
L3	P01.13	I	MP+ / PU1 / VEXT	General-purpose input
	TIN161			GTM input
	P01.13	O0		General-purpose output
	TOUT161	O1		GTM output
	ATX0	O2		ASCLIN0 output
	—	O3		Reserved
	TXDCAN0	O4		CAN node 0 output
	TXDCANr0	O5		CAN node 0 output (MultiCANr+)
	TXD1B	O6		ERAY1 output
	—	O7		Reserved
L2	P01.14	I	MP+ / PU1 / VEXT	General-purpose input
	TIN164			GTM input
	P01.14	O0		General-purpose output
	TOUT164	O1		GTM output
	—	O2		Reserved
	—	O3		Reserved
	—	O4		Reserved
	—	O5		Reserved
	TXEN1A	O6		ERAY1 output
	—	O7		Reserved

Package and Pinning Definitions TC298x Pin Definition and Functions:

Table 2-28 Port 01 Functions (cont'd)

Pin	Symbol	Ctrl	Type	Function
L1	P01.15	I	LP / PU1 / VEXT	General-purpose input
	TIN157			GTM input
	DSDIN7A			DSADC channel 7 input A
	P01.15	O0		General-purpose output
	TOUT157	O1		GTM output
	—	O2		Reserved
	—	O3		Reserved
	—	O4		Reserved
	—	O5		Reserved
	—	O6		Reserved
	—	O7		Reserved

Table 2-29 Port 02 Functions

Pin	Symbol	Ctrl	Type	Function
B2	P02.0	I	MP+ / PU1 / VEXT	General-purpose input
	TIN0			GTM input
	REQ6			SCU input
	ARX2G			ASCLIN2 input
	CC60INA			CCU60 input
	CC60INB			CCU61 input
	CIFD0			CIF input
	P02.0			O0
	TOUT0	O1		GTM output
	ATX2	O2		ASCLIN2 output
	SLSO31	O3		QSPI3 output
	DSCGPWMN	O4		DSADC output
	TXDCAN0	O5		CAN node 0 output
	TXD0A	O6		ERAY0 output
	CC60	O7		CCU60 output

Package and Pinning Definitions TC298x Pin Definition and Functions:

Table 2-29 Port 02 Functions (cont'd)

Pin	Symbol	Ctrl	Type	Function
B1	P02.1	I	LP / PU1 / VEXT	General-purpose input
	TIN1			GTM input
	REQ14			SCU input
	ARX2B			ASCLIN2 input
	RXDCAN0A			CAN node 0 input
	RXD0A2			ERAY0 input
	CIFD1			CIF input
	P02.1			O0
	TOUT1	O1		GTM output
	SLSO47	O2		QSPI4 output
	SLSO32	O3		QSPI3 output
	DSCGPWMP	O4		DSADC output
	–	O5		Reserved
	–	O6		Reserved
	COU60	O7		CCU60 output
E2	P02.2	I	MP+ / PU1 / VEXT	General-purpose input
	TIN2			GTM input
	CC61INA			CCU60 input
	CC61INB			CCU61 input
	CIFD2			CIF input
	P02.2	O0		General-purpose output
	TOUT2	O1		GTM output
	ATX1	O2		ASCLIN1 output
	SLSO33	O3		QSPI3 output
	PSITX0	O4		PSI5 output
	TXDCAN2	O5		CAN node 2 output
	TXD0B	O6		ERAY0 output
	CC61	O7		CCU60 output

Package and Pinning Definitions TC298x Pin Definition and Functions:

Table 2-29 Port 02 Functions (cont'd)

Pin	Symbol	Ctrl	Type	Function
F2	P02.3	I	LP / PU1 / VEXT	General-purpose input
	TIN3			GTM input
	ARX1G			ASCLIN1 input
	RXDCAN2B			CAN node 2 input
	RXD0B2			ERAY0 input
	PSIRX0B			PSI5 input
	DSCIN5B			DSADC channel 5 input B
	SDI11			MSC1 input
	CIFD3			CIF input
	P02.3			O0
	TOUT3	O1		GTM output
	ASLSO2	O2		ASCLIN2 output
	SLSO34	O3		QSPI3 output
	DSCOUT5	O4		DSADC channel 5 output
	–	O5		Reserved
	–	O6		Reserved
	COUT61	O7		CCU60 output
	C1	P02.4		I
TIN4		GTM input		
SLSI3A		QSPI3 input		
ECTT1		TTCAN input		
RXDCAN0D		CAN node 0 input		
CC62INA		CCU60 input		
CC62INB		CCU61 input		
DSDIN5B		DSADC channel 5 input B		
SDA0A		I2C0 input		
CIFD4		CIF input		
P02.4		O0	General-purpose output	
TOUT4		O1	GTM output	
ASCLK2		O2	ASCLIN2 output	
SLSO30		O3	QSPI3 output	
PSISCLK		O4	PSI5-S output	
SDA0		O5	I2C0 output	
TXEN0A		O6	ERAY0 output	
CC62		O7	CCU60 output	

Package and Pinning Definitions TC298x Pin Definition and Functions:

Table 2-29 Port 02 Functions (cont'd)

Pin	Symbol	Ctrl	Type	Function
D4	P02.5	I	MP+ / PU1 / VEXT	General-purpose input
	TIN5			GTM input
	MRST3A			QSPI3 input
	ECTT2			TTCAN input
	PSIRX1B			PSI5 input
	PSISRXB			PSI5-S input
	SENT3C			SENT input
	DSCIN4B			DSADC channel 4 input B
	SCL0A			I2C0 input
	CIFD5			CIF input
	P02.5			O0
	TOUT5	O1		GTM output
	TXDCAN0	O2		CAN node 0 output
	MRST3	O3		QSPI3 output
	DSCOUT4	O4		DSADC channel 4 output
	SCL0	O5		I2C0 output
	TXEN0B	O6		ERAY0 output
	COUT62	O7		CCU60 output
H2	P02.6	I	MP / PU1 / VEXT	General-purpose input
	TIN6			GTM input
	MTR3A			QSPI3 input
	SENT2C			SENT input
	CC60INC			CCU60 input
	CCPOS0A			CCU60 input
	T12HRB			CCU61 input
	T3INA			GPT120 input
	CIFD6			CIF input
	DSDIN4B			DSADC channel 4 input B
	DSITR5E			DSADC channel 5 input E
	P02.6	O0		General-purpose output
	TOUT6	O1		GTM output
	PSISTX	O2		PSI5-S output
	MTR3	O3		QSPI3 output
	PSITX1	O4		PSI5 output
	VADCEMUX00	O5		VADC output
	—	O6		Reserved
CC60	O7	CCU60 output		

Package and Pinning Definitions TC298x Pin Definition and Functions:

Table 2-29 Port 02 Functions (cont'd)

Pin	Symbol	Ctrl	Type	Function
H1	P02.7	I	MP / PU1 / VEXT	General-purpose input
	TIN7			GTM input
	SCLK3A			QSPI3 input
	PSIRX2B			PSI5 input
	SENT1C			SENT input
	CC61INC			CCU60 input
	CCPOS1A			CCU60 input
	T13HRB			CCU61 input
	T3EUDA			GPT120 input
	CIFD7			CIF input
	DSCIN3B			DSADC channel 3 input B
	DSITR4E			DSADC channel 4 input E
	P02.7			O0
	TOUT7	O1		GTM output
	–	O2		Reserved
	SCLK3	O3		QSPI3 output
	DSCOUT3	O4		DSADC channel 3 output
	VADCEMUX01	O5		VADC output
	SPC1	O6		SENT output
	CC61	O7		CCU60 output

Package and Pinning Definitions TC298x Pin Definition and Functions:

Table 2-29 Port 02 Functions (cont'd)

Pin	Symbol	Ctrl	Type	Function
J3	P02.8	I	LP / PU1 / VEXT	General-purpose input
	TIN8			GTM input
	SENT0C			SENT input
	CC62INC			CCU60 input
	CCPOS2A			CCU60 input
	T12HRC			CCU61 input
	T13HRC			CCU61 input
	T4INA			GPT120 input
	CIFD8			CIF input
	DSDIN3B			DSADC channel 3 input B
	DSITR3E			DSADC channel 3 input E
	P02.8	O0	General-purpose output	
	TOUT8	O1	GTM output	
	SLSO35	O2	QSPI3 output	
	–	O3	Reserved	
	PSITX2	O4	PSI5 output	
	VADCEMUX02	O5	VADC output	
ETHMDC	O6	ETH output		
CC62	O7	CCU60 output		
E4	P02.9	I	LP / PU1 / VEXT	General-purpose input
	TIN116			GTM input
	P02.9	O0		General-purpose output
	TOUT116	O1		GTM output
	ATX2	O2		ASCLIN2 output
	–	O3		Reserved
	–	O4		Reserved
	TXDCAN1	O5		CAN node 1 output
	–	O6		Reserved
	–	O7		Reserved

Package and Pinning Definitions TC298x Pin Definition and Functions:

Table 2-29 Port 02 Functions (cont'd)

Pin	Symbol	Ctrl	Type	Function
F4	P02.10	I	LP / PU1 / VEXT	General-purpose input
	TIN117			GTM input
	ARX2C			ASCLIN2 input
	RXDCAN1E			CAN node 1 input
	P02.10	O0		General-purpose output
	TOUT117	O1		GTM output
	—	O2		Reserved
	—	O3		Reserved
	—	O4		Reserved
	—	O5		Reserved
	—	O6		Reserved
—	O7	Reserved		
C2	P02.11	I	LP / PU1 / VEXT	General-purpose input
	TIN118			GTM input
	P02.11	O0		General-purpose output
	TOUT118	O1		GTM output
	—	O2		Reserved
	—	O3		Reserved
	—	O4		Reserved
	—	O5		Reserved
	—	O6		Reserved
	—	O7		Reserved
	D3	P02.12		I
TIN151		GTM input		
P02.12		O0	General-purpose output	
TOUT151		O1	GTM output	
SLSO35		O2	QSPI3 output	
SLSO44		O3	QSPI4 output	
—		O4	Reserved	
—		O5	Reserved	
—		O6	Reserved	
—		O7	Reserved	

Package and Pinning Definitions TC298x Pin Definition and Functions:

Table 2-29 Port 02 Functions (cont'd)

Pin	Symbol	Ctrl	Type	Function
D1	P02.13	I	LP / PU1 / VEXT	General-purpose input
	TIN153			GTM input
	P02.13	O0		General-purpose output
	TOUT153	O1		GTM output
	SLSO37	O2		QSPI3 output
	SLSO46	O3		QSPI4 output
	TXDCAN0	O4		CAN node 0 output
	TXDCANr0	O5		CAN node 0 output (MultiCANr+)
	—	O6		Reserved
	—	O7		Reserved
E1	P02.14	I	LP / PU1 / VEXT	General-purpose input
	TIN154			GTM input
	RXDCAN0H			CAN node 0 input
	RXDCANr0D			CAN node 0 input (MultiCANr+)
	P02.14	O0		General-purpose output
	TOUT154	O1		GTM output
	—	O2		Reserved
	—	O3		Reserved
	—	O4		Reserved
	—	O5		Reserved
	—	O6		Reserved
	—	O7		Reserved
D2	P02.15	I	MP+ / PU1 / VEXT	General-purpose input
	TIN152			GTM input
	P02.15	O0		General-purpose output
	TOUT152	O1		GTM output
	SLSO36	O2		QSPI3 output
	SLSO45	O3		QSPI4 output
	—	O4		Reserved
	—	O5		Reserved
	TXEN1B	O6		ERAY1 output
	—	O7		Reserved

Package and Pinning Definitions TC298x Pin Definition and Functions:

Table 2-30 Port 10 Functions

Pin	Symbol	Ctrl	Type	Function
A9	P10.0	I	LP / PU1 / VEXT	General-purpose input
	TIN102			GTM input
	T6EUDB			GPT120 input
	P10.0	O0		General-purpose output
	TOUT102	O1		GTM output
	–	O2		Reserved
	SLSO110	O3		QSPI1 output
	–	O4		Reserved
	VADCG6BFL0	O5		VADC output
	–	O6		Reserved
	–	O7		Reserved
	B8	P10.1		I
TIN103		GTM input		
MRST1A		QSPI1 input		
T5EUDB		GPT120 input		
P10.1		O0	General-purpose output	
TOUT103		O1	GTM output	
MTSR1		O2	QSPI1 output	
MRST1		O3	QSPI1 output	
EN01		O4	MSC0 output	
VADCG6BFL1		O5	VADC output	
END03		O6	MSC0 output	
–		O7	Reserved	
A7	P10.2	I	MP / PU1 / VEXT	General-purpose input
	TIN104			GTM input
	SCLK1A			QSPI1 input
	T6INB			GPT120 input
	REQ2			SCU input
	RXDCAN2E			CAN node 2 input
	SDI01			MSC0 input
	P10.2			O0
	TOUT104	O1		GTM output
	–	O2		Reserved
	SCLK1	O3		QSPI1 output
	EN00	O4		MSC0 output
	VADCG6BFL2	O5		VADC output
	END02	O6		MSC0 output
	–	O7		Reserved

Package and Pinning Definitions TC298x Pin Definition and Functions:

Table 2-30 Port 10 Functions (cont'd)

Pin	Symbol	Ctrl	Type	Function
B7	P10.3	I	MP / PU1 / VEXT	General-purpose input
	TIN105			GTM input
	MTSR1A			QSPI1 input
	REQ3			SCU input
	T5INB			GPT120 input
	P10.3			O0
	TOUT105	O1		GTM output
	VADCG6BFL3	O2		VADC output
	MTSR1	O3		QSPI1 output
	EN00	O4		MSC0 output
	END02	O5		MSC0 output
	TXDCAN2	O6		CAN node 2 output
	–	O7		Reserved
	A8	P10.4		I
TIN106		GTM input		
MTSR1C		QSPI1 input		
CCPOS0C		CCU60 input		
T3INB		GPT120 input		
P10.4		O0	General-purpose output	
TOUT106		O1	GTM output	
–		O2	Reserved	
SLSO18		O3	QSPI1 output	
MTSR1		O4	QSPI1 output	
EN00		O5	MSC0 output	
END02		O6	MSC0 output	
–		O7	Reserved	

Package and Pinning Definitions TC298x Pin Definition and Functions:

Table 2-30 Port 10 Functions (cont'd)

Pin	Symbol	Ctrl	Type	Function
A6	P10.5	I	LP / PU1 / VEXT	General-purpose input
	TIN107			GTM input
	HWCFG4			SCU input
	RXDCANr0A			CAN node 0 input (MultiCANr+)
	INJ01			MSC0 input
	P10.5	O0		General-purpose output
	TOUT107	O1		GTM output
	ATX2	O2		ASCLIN2 output
	SLSO38	O3		QSPI3 output
	SLSO19	O4		QSPI1 output
	T6OUT	O5		GPT120 output
	ASLSO2	O6		ASCLIN2 output
	PSITX3	O7		PSI5 output
	G2	P10.6		I
TIN108		GTM input		
ARX2D		ASCLIN2 input		
MTSR3B		QSPI3 input		
PSIRX3C		PSI5 input		
HWCFG5		SCU input		
P10.6		O0	General-purpose output	
TOUT108		O1	GTM output	
ASCLK2		O2	ASCLIN2 output	
MTSR3		O3	QSPI3 output	
T3OUT		O4	GPT120 output	
TXDCANr0		O5	CAN node 0 output (MultiCANr+)	
MRST1		O6	QSPI1 output	
VADCG7BFL0		O7	VADC output	

Package and Pinning Definitions TC298x Pin Definition and Functions:

Table 2-30 Port 10 Functions (cont'd)

Pin	Symbol	Ctrl	Type	Function
B4	P10.7	I	LP / PU1 / VEXT	General-purpose input
	TIN109			GTM input
	ACTS2A			ASCLIN2 input
	MRST3B			QSPI3 input
	REQ4			SCU input
	CCPOS1C			CCU60 input
	T3EUDB			GPT120 input
	P10.7			O0
	TOUT109	O1		GTM output
	–	O2		Reserved
	MRST3	O3		QSPI3 output
	VADCG7BFL1	O4		VADC output
	TXDCANr0	O5		CAN node 0 output (MultiCANr+)
	–	O6		Reserved
	–	O7		Reserved
A4	P10.8	I	LP / PU1 / VEXT	General-purpose input
	TIN110			GTM input
	SCLK3B			QSPI3 input
	REQ5			SCU input
	CCPOS2C			CCU60 input
	T4INB			GPT120 input
	RXDCANr0B			CAN node 0 input (MultiCANr+)
	P10.8			O0
	TOUT110	O1		GTM output
	ARTS2	O2		ASCLIN2 output
	SCLK3	O3		QSPI3 output
	–	O4		Reserved
	–	O5		Reserved
	–	O6		Reserved
	–	O7		Reserved

Package and Pinning Definitions TC298x Pin Definition and Functions:

Table 2-30 Port 10 Functions (cont'd)

Pin	Symbol	Ctrl	Type	Function
B6	P10.9	I	LP / PU1 / VEXT	General-purpose input
	TIN265			GTM input
	SENT10C			SENT input
	P10.9	O0		General-purpose output
	TOUT265	O1		GTM output
	—	O2		Reserved
	—	O3		Reserved
	—	O4		Reserved
	—	O5		Reserved
	—	O6		Reserved
—	O7	Reserved		
C4	P10.10	I	LP / PU1 / VEXT	General-purpose input
	TIN266			GTM input
	SENT11C			SENT input
	P10.10	O0		General-purpose output
	TOUT266	O1		GTM output
	—	O2		Reserved
	—	O3		Reserved
	—	O4		Reserved
	—	O5		Reserved
	—	O6		Reserved
—	O7	Reserved		
A3	P10.11	I	LP / PU1 / VEXT	General-purpose input
	TIN269			GTM input
	SENT14C			SENT input
	P10.11	O0		General-purpose output
	TOUT269	O1		GTM output
	—	O2		Reserved
	—	O3		Reserved
	—	O4		Reserved
	—	O5		Reserved
	—	O6		Reserved
—	O7	Reserved		

Package and Pinning Definitions TC298x Pin Definition and Functions:

Table 2-30 Port 10 Functions (cont'd)

Pin	Symbol	Ctrl	Type	Function
B3	P10.13	I	LP / PU1 / VEXT	General-purpose input
	TIN268			GTM input
	SENT13C			SENT input
	P10.13	O0		General-purpose output
	TOUT268	O1		GTM output
	—	O2		Reserved
	—	O3		Reserved
	—	O4		Reserved
	—	O5		Reserved
	—	O6		Reserved
—	O7	Reserved		
C3	P10.14	I	LP / PU1 / VEXT	General-purpose input
	TIN267			GTM input
	SENT12C			SENT input
	P10.14	O0		General-purpose output
	TOUT267	O1		GTM output
	—	O2		Reserved
	—	O3		Reserved
	—	O4		Reserved
	—	O5		Reserved
	—	O6		Reserved
—	O7	Reserved		
A2	P10.15	I	LP / PU1 / VEXT	General-purpose input
	TIN270			GTM input
	P10.15			O0
	TOUT270	O1		GTM output
	—	O2		Reserved
	—	O3		Reserved
	—	O4		Reserved
	—	O5		Reserved
	—	O6		Reserved
	—	O7		Reserved

Package and Pinning Definitions TC298x Pin Definition and Functions:

Table 2-31 Port 11 Functions

Pin	Symbol	Ctrl	Type	Function
D11	P11.0	I	MP+ / PU1 / VFLEX	General-purpose input
	TIN119			GTM input
	ARX3B			ASCLIN3 input
	P11.0	O0		General-purpose output
	TOUT119	O1		GTM output
	ATX3	O2		ASCLIN3 output
	–	O3		Reserved
	–	O4		Reserved
	–	O5		Reserved
	ETHTXD3	O6		ETH output
	–	O7		Reserved
C11	P11.1	I	MP+ / PU1 / VFLEX	General-purpose input
	TIN120			GTM input
	P11.1			O0
	TOUT120	O1		GTM output
	ASCLK3	O2		ASCLIN3 output
	ATX3	O3		ASCLIN3 output
	–	O4		Reserved
	–	O5		Reserved
	ETHTXD2	O6		ETH output
	–	O7		Reserved
	D10	P11.2		I
TIN95		GTM input		
P11.2		O0	General-purpose output	
TOUT95		O1	GTM output	
END03		O2	MSC0 output	
SLSO05		O3	QSPI0 output	
SLSO15		O4	QSPI1 output	
EN01		O5	MSC0 output	
ETHTXD1		O6	ETH output	
COUT63		O7	CCU60 output	

Package and Pinning Definitions TC298x Pin Definition and Functions:

Table 2-31 Port 11 Functions (cont'd)

Pin	Symbol	Ctrl	Type	Function
A5	P11.3	I	MPR / PU1 / VFLEX	General-purpose input
	TIN96			GTM input
	MRST1B			QSPI1 input
	SDI03			MSC0 input
	P11.3	O0		General-purpose output
	TOUT96	O1		GTM output
	–	O2		Reserved
	MRST1	O3		QSPI1 output
	TXD0A	O4		ERAY0 output
	–	O5		Reserved
	ETHTXD0	O6		ETH output
	COUT62	O7		CCU60 output
C10	P11.4	I	MP+ / PU1 / VFLEX	General-purpose input
	TIN121			GTM input
	ETHRXCLKB			ETH input
	P11.4			General-purpose output
	TOUT121	O1		GTM output
	ASCLK3	O2		ASCLIN3 output
	–	O3		Reserved
	–	O4		Reserved
	–	O5		Reserved
	ETHTXER	O6		ETH output
	–	O7		Reserved
	B10	P11.5		I
TIN122		GTM input		
ETHTXCLKA		ETH input		
P11.5		General-purpose output		
TOUT122		O1	GTM output	
–		O2	Reserved	
–		O3	Reserved	
–		O4	Reserved	
–		O5	Reserved	
–		O6	Reserved	
–		O7	Reserved	

Package and Pinning Definitions TC298x Pin Definition and Functions:

Table 2-31 Port 11 Functions (cont'd)

Pin	Symbol	Ctrl	Type	Function
C6	P11.6	I	MPR / PU1 / VFLEX	General-purpose input
	TIN97			GTM input
	SCLK1B			QSPI1 input
	P11.6	O0		General-purpose output
	TOUT97	O1		GTM output
	TXEN0B	O2		ERAY0 output
	SCLK1	O3		QSPI1 output
	TXEN0A	O4		ERAY0 output
	FCLP0	O5		MSC0 output
	ETHTXEN	O6		ETH output
	COU61	O7		CCU60 output
A10	P11.7	I	LP / PU1 / VFLEX	General-purpose input
	TIN123			GTM input
	ETHRXD3			ETH input
	P11.7	O0		General-purpose output
	TOUT123	O1		GTM output
	–	O2		Reserved
	–	O3		Reserved
	–	O4		Reserved
	–	O5		Reserved
	–	O6		Reserved
	–	O7		Reserved
C9	P11.8	I	LP / PU1 / VFLEX	General-purpose input
	TIN124			GTM input
	ETHRXD2			ETH input
	P11.8	O0		General-purpose output
	TOUT124	O1		GTM output
	–	O2		Reserved
	–	O3		Reserved
	–	O4		Reserved
	–	O5		Reserved
	–	O6		Reserved
	–	O7		Reserved

Package and Pinning Definitions TC298x Pin Definition and Functions:

Table 2-31 Port 11 Functions (cont'd)

Pin	Symbol	Ctrl	Type	Function
B5	P11.9	I	MP+ / PU1 / VFLEX	General-purpose input
	TIN98			GTM input
	MTSR1B			QSPI1 input
	RXD0A1			ERAY0 input
	ETHRXD1			ETH input
	P11.9			O0
	TOUT98	O1		GTM output
	–	O2		Reserved
	MTSR1	O3		QSPI1 output
	–	O4		Reserved
	SOP0	O5		MSC0 output
	–	O6		Reserved
	COUT60	O7		CCU60 output
	D5	P11.10		I
TIN99		GTM input		
REQ12		SCU input		
ARX1E		ASCLIN1 input		
SLS1A		QSPI1 input		
RXDCAN3D		CAN node 3 input		
RXD0B1		ERAY0 input		
ETHRXD0		ETH input		
SDI00		MSC0 input		
P11.10		O0	General-purpose output	
TOUT99		O1	GTM output	
–		O2	Reserved	
SLSO03		O3	QSPI0 output	
SLSO13		O4	QSPI1 output	
–		O5	Reserved	
–		O6	Reserved	
CC62		O7	CCU60 output	

Package and Pinning Definitions TC298x Pin Definition and Functions:

Table 2-31 Port 11 Functions (cont'd)

Pin	Symbol	Ctrl	Type	Function
D6	P11.11	I	MP+ / PU1 / VFLEX	General-purpose input
	TIN100			GTM input
	ETHCRSDVA			ETH input
	ETHRXDVA			ETH input
	ETHCRSB			ETH input
	P11.11	O0		General-purpose output
	TOUT100	O1		GTM output
	END02	O2		MSC0 output
	SLSO04	O3		QSPI0 output
	SLSO14	O4		QSPI1 output
	EN00	O5		MSC0 output
	TXEN0B	O6		ERAY0 output
	CC61	O7		CCU60 output
C5	P11.12	I	MPR / PU1 / VFLEX	General-purpose input
	TIN101			GTM input
	ETHREFCLK			ETH input
	ETHTXCLKB			ETH input (Not for productive purposes)
	ETHRXCLKA			ETH input (Not for productive purposes)
	P11.12	O0		General-purpose output
	TOUT101	O1		GTM output
	ATX1	O2		ASCLIN1 output
	GTMCLK2	O3		GTM output
	TXD0B	O4		ERAY0 output
	TXDCAN3	O5		CAN node 3 output
	EXTCLK1	O6		SCU output
	CC60	O7		CCU60 output

Package and Pinning Definitions TC298x Pin Definition and Functions:

Table 2-31 Port 11 Functions (cont'd)

Pin	Symbol	Ctrl	Type	Function	
B9	P11.13	I	LP / PU1 / VFLEX	General-purpose input	
	TIN125			GTM input	
	ETHRXERA			ETH input	
	SDA1A			I2C1 input	
	P11.13			O0	General-purpose output
	TOUT125			O1	GTM output
	–			O2	Reserved
	–			O3	Reserved
	–			O4	Reserved
	–			O5	Reserved
	SDA1			O6	I2C1 output
	–			O7	Reserved
C8	P11.14	I	LP / PU1 / VFLEX	General-purpose input	
	TIN126			GTM input	
	ETHCRSDVB			ETH input	
	ETHRXDVB			ETH input	
	ETHCRSA			ETH input	
	SCL1A			I2C1 input	
	P11.14			O0	General-purpose output
	TOUT126			O1	GTM output
	–			O2	Reserved
	–			O3	Reserved
	–			O4	Reserved
	–			O5	Reserved
SCL1	O6	I2C1 output			
–	O7	Reserved			
C7	P11.15	I	LP / PU1 / VFLEX	General-purpose input	
	TIN127			GTM input	
	ETHCOL			ETH input	
	P11.15			O0	General-purpose output
	TOUT127			O1	GTM output
	–			O2	Reserved
	–			O3	Reserved
	–			O4	Reserved
	–			O5	Reserved
	–			O6	Reserved
	–			O7	Reserved

Package and Pinning Definitions TC298x Pin Definition and Functions:

Table 2-32 Port 12 Functions

Pin	Symbol	Ctrl	Type	Function	
A11	P12.0	I	LP / PU1 / VFLEX	General-purpose input	
	TIN128			GTM input	
	ETHRXCLKC			ETH input	
	RXDCAN0C			CAN node 0 input	
	P12.0	O0		General-purpose output	
	TOUT128	O1		GTM output	
	—	O2		Reserved	
	—	O3		Reserved	
	—	O4		Reserved	
	—	O5		Reserved	
	ETHMDC	O6		ETH output	
	—	O7		Reserved	
B11	P12.1	I	LP / PU1 / VFLEX	General-purpose input	
	TIN129			GTM input	
	P12.1			O0	General-purpose output
	TOUT129			O1	GTM output
	ASLSO3	O2		ASCLIN3 output	
	—	O3		Reserved	
	—	O4		Reserved	
	TXDCAN0	O5		CAN node 0 output	
	—	O6		Reserved	
	—	O7		Reserved	
	ETHMDIOC	HWOUT		ETH input/output	

Table 2-33 Port 13 Functions

Pin	Symbol	Ctrl	Type	Function
C17	P13.0	I	LVDSM_N / PU1 / VEXT	General-purpose input
	TIN91			GTM input
	P13.0	O0		General-purpose output
	TOUT91	O1		GTM output
	END03	O2		MSC0 output
	SCLK2N	O3		QSPI2 output (LVDS)
	EN01	O4		MSC0 output
	FCLN0	O5		MSC0 output (LVDS)
	FCLND0	O6		MSC0 output (LVDS)
	—	O7		Reserved

Package and Pinning Definitions TC298x Pin Definition and Functions:

Table 2-33 Port 13 Functions (cont'd)

Pin	Symbol	Ctrl	Type	Function
C18	P13.1	I	LVDSM_P / PU1 / VEXT	General-purpose input
	TIN92			GTM input
	SCL0B			I2C0 input
	P13.1	O0		General-purpose output
	TOUT92	O1		GTM output
	–	O2		Reserved
	SCLK2P	O3		QSPI2 output (LVDS)
	–	O4		Reserved
	FCLP0	O5		MSC0 output (LVDS)
	SCL0	O6		I2C0 output
	–	O7		Reserved
	D17	P13.2		I
TIN93		GTM input		
CAPINA		GPT120 input		
SDA0B		I2C0 input		
P13.2		O0	General-purpose output	
TOUT93		O1	GTM output	
–		O2	Reserved	
MTSR2N		O3	QSPI2 output (LVDS)	
FCLP0		O4	MSC0 output	
SON0		O5	MSC0 output (LVDS)	
SDA0		O6	I2C0 output	
SOND0		O7	MSC0 output (LVDS)	
C16	P13.3	I	LVDSM_P / PU1 / VEXT	General-purpose input
	TIN94			GTM input
	P13.3	O0		General-purpose output
	TOUT94	O1		GTM output
	–	O2		Reserved
	MTSR2P	O3		QSPI2 output (LVDS)
	–	O4		Reserved
	SOP0	O5		MSC0 output (LVDS)
	–	O6		Reserved
	–	O7		Reserved

Package and Pinning Definitions TC298x Pin Definition and Functions:

Table 2-33 Port 13 Functions (cont'd)

Pin	Symbol	Ctrl	Type	Function
B17	P13.4	I	LVDSM_N / PU1 / VEXT	General-purpose input
	TIN253			GTM input
	PSIRX4A			PSI5 input
	P13.4	O0		General-purpose output
	TOUT253	O1		GTM output
	END22	O2		MSC2 output
	–	O3		Reserved
	EN20	O4		MSC2 output
	FCLN2	O5		MSC2 output (LVDS)
	FCLND2	O6		MSC2 output (LVDS)
	–	O7		Reserved
A17	P13.5	I	LVDSM_P / PU1 / VEXT	General-purpose input
	TIN254			GTM input
	P13.5			O0
	TOUT254	O1		GTM output
	–	O2		Reserved
	–	O3		Reserved
	–	O4		Reserved
	FCLP2	O5		MSC2 output (LVDS)
	–	O6		Reserved
	–	O7		Reserved
	A16	P13.6		I
TIN255		GTM input		
P13.6		O0	General-purpose output	
TOUT255		O1	GTM output	
–		O2	Reserved	
–		O3	Reserved	
–		O4	Reserved	
SON2		O5	MSC2 output (LVDS)	
SOND2		O6	MSC2 output (LVDS)	
–		O7	Reserved	

Package and Pinning Definitions TC298x Pin Definition and Functions:

Table 2-33 Port 13 Functions (cont'd)

Pin	Symbol	Ctrl	Type	Function
B16	P13.7	I	LVDSM_P / PU1 / VEXT	General-purpose input
	TIN256			GTM input
	P13.7			General-purpose output
	TOUT256	O1		GTM output
	—	O2		Reserved
	—	O3		Reserved
	—	O4		Reserved
	SOP2	O5		MSC2 output (LVDS)
	—	O6		Reserved
	—	O7		Reserved
C12	P13.9	I	MP / PU1 / VEXT	General-purpose input
	TIN248			GTM input
	SCL1B			I2C1 input
	P13.9	O0		General-purpose output
	TOUT248	O1		GTM output
	ATX3	O2		ASCLIN3 output
	SLSO55	O3		QSPI5 output
	—	O4		Reserved
	TXDCANr1	O5		CAN node 1 output (MultiCANr+)
	SCL1	O6		I2C1 output
	—	O7		Reserved
A13	P13.10	I	LP / PU1 / VEXT	General-purpose input
	TIN251			GTM input
	PSIRX3A			PSI5 input
	P13.10	O0		General-purpose output
	TOUT251	O1		GTM output
	ATX0	O2		ASCLIN0 output
	—	O3		Reserved
	—	O4		Reserved
	—	O5		Reserved
	—	O6		Reserved
	—	O7		Reserved

Package and Pinning Definitions TC298x Pin Definition and Functions:

Table 2-33 Port 13 Functions (cont'd)

Pin	Symbol	Ctrl	Type	Function
B13	P13.11	I	LP / PU1 / VEXT	General-purpose input
	TIN250			GTM input
	ARX0E			ASCLIN0 input
	P13.11	O0		General-purpose output
	TOUT250	O1		GTM output
	—	O2		Reserved
	—	O3		Reserved
	—	O4		Reserved
	PSITX3	O5		PSI5 output
	—	O6		Reserved
	—	O7		Reserved
B12	P13.12	I	LP / PU1 / VEXT	General-purpose input
	TIN249			GTM input
	ARX3H			ASCLIN3 input
	RXDCANr1B			CAN node 1 input (MultiCANr+)
	SDA1B			I2C1 input
	P13.12	O0		General-purpose output
	TOUT249	O1		GTM output
	—	O2		Reserved
	—	O3		Reserved
	—	O4		Reserved
	—	O5		Reserved
SDA1	O6	I2C1 output		
—	O7	Reserved		
A12	P13.14	I	LP / PU1 / VEXT	General-purpose input
	TIN252			GTM input
	P13.14	O0		General-purpose output
	TOUT252	O1		GTM output
	—	O2		Reserved
	SLSO54	O3		QSPI5 output
	—	O4		Reserved
	—	O5		Reserved
	—	O6		Reserved
	—	O7		Reserved

Package and Pinning Definitions TC298x Pin Definition and Functions:

Table 2-34 Port 14 Functions

Pin	Symbol	Ctrl	Type	Function	
C21	P14.0	I	MP+ / PU1 / VEXT	General-purpose input	
	TIN80			GTM input	
	SENT12D			SENT input	
	P14.0	O0		General-purpose output	
	TOUT80	O1		GTM output	
	ATX0	O2		ASCLIN0 output Recommended as Boot loader pin	
	TXD0A	O3		ERAY0 output	
	TXD0B	O4		ERAY0 output	
	TXDCAN1	O5		CAN node 1 output Used for single pin DAP (SPD) function	
	ASCLK0	O6		ASCLIN0 output	
	COU62	O7		CCU60 output	
D21	P14.1	I	MP / PU1 / VEXT	General-purpose input	
	TIN81			GTM input	
	REQ15			SCU input	
	SENT13D			SENT input	
	ARX0A			ASCLIN0 input Recommended as Boot loader pin	
	RXDCAN1B			CAN node 1 input Used for single pin DAP (SPD) function	
	RXD0A3			ERAY0 input	
	RXD0B3			ERAY0 input	
	EVRWUPA			SCU input	
	P14.1			O0	General-purpose output
	TOUT81			O1	GTM output
	ATX0	O2		ASCLIN0 output Recommended as Boot loader pin.	
	-	O3		Reserved	
	-	O4		Reserved	
	-	O5		Reserved	
	-	O6		Reserved	
	COU63	O7		CCU60 output	

Package and Pinning Definitions TC298x Pin Definition and Functions:

Table 2-34 Port 14 Functions (cont'd)

Pin	Symbol	Ctrl	Type	Function		
D20	P14.2	I	LP / PU1 / VEXT	General-purpose input		
	TIN82			GTM input		
	HWCFG2 EVR13			SCU input Latched at cold power on reset to decide EVR13 activation.		
	P14.2	O0		General-purpose output		
	TOUT82	O1		GTM output		
	ATX2	O2		ASCLIN2 output		
	SLSO21	O3		QSPI2 output		
	–	O4		Reserved		
	–	O5		Reserved		
	ASCLK2	O6		ASCLIN2 output		
	–	O7		Reserved		
	C14	P14.3		I	LP / PU1 / VEXT	General-purpose input
		TIN83				GTM input
ARX2A		ASCLIN2 input				
REQ10		SCU input				
HWCFG3_BMI		SCU input				
SDI02		MSC0 input				
P14.3		O0	General-purpose output			
TOUT83		O1	GTM output			
ATX2		O2	ASCLIN2 output			
SLSO23		O3	QSPI2 output			
ASLSO1		O4	ASCLIN1 output			
ASLSO3		O5	ASCLIN3 output			
–		O6	Reserved			
–		O7	Reserved			

Package and Pinning Definitions TC298x Pin Definition and Functions:

Table 2-34 Port 14 Functions (cont'd)

Pin	Symbol	Ctrl	Type	Function
D13	P14.4	I	LP / PU1 / VEXT	General-purpose input
	TIN84			GTM input
	HWCFG6			SCU input Latched at cold power on reset to decide default pad reset state (PU or HighZ).
	P14.4	O0		General-purpose output
	TOUT84	O1		GTM output
	—	O2		Reserved
	—	O3		Reserved
	—	O4		Reserved
	—	O5		Reserved
	—	O6		Reserved
—	O7	Reserved		
C20	P14.5	I	MP+ / PU1 / VEXT	General-purpose input
	TIN85			GTM input
	HWCFG1 EVR33			SCU input Latched at cold power on reset to decide EVR33 activation.
	P14.5	O0		General-purpose output
	TOUT85	O1		GTM output
	—	O2		Reserved
	—	O3		Reserved
	—	O4		Reserved
	—	O5		Reserved
	TXD0B	O6		ERAY0 output
TXD1B	O7	ERAY1 output		
C13	P14.6	I	MP+ / PU1 / VEXT	General-purpose input
	TIN86			GTM input
	HWCFG0 DCLDO			SCU input If EVR13 active, latched at cold power on reset to decide between LDO and SMPS mode.
	P14.6	O0		General-purpose output
	TOUT86	O1		GTM output
	—	O2		Reserved
	SLSO22	O3		QSPI2 output
	—	O4		Reserved
	—	O5		Reserved
	TXEN0B	O6		ERAY0 output
TXEN1B	O7	ERAY1 output		

Package and Pinning Definitions TC298x Pin Definition and Functions:

Table 2-34 Port 14 Functions (cont'd)

Pin	Symbol	Ctrl	Type	Function
D12	P14.7	I	LP / PU1 / VEXT	General-purpose input
	TIN87			GTM input
	RXD0B0			ERAY0 input
	RXD1B0			ERAY1 input
	P14.7	O0		General-purpose output
	TOUT87	O1		GTM output
	ARTS0	O2		ASCLIN0 output
	SLSO24	O3		QSPI2 output
	—	O4		Reserved
	—	O5		Reserved
	—	O6		Reserved
	—	O7		Reserved
A14	P14.8	I	LP / PU1 / VEXT	General-purpose input
	TIN88			GTM input
	ARX1D			ASCLIN1 input
	RXDCAN2D			CAN node 2 input
	RXD0A0			ERAY0 input
	RXD1A0			ERAY1 input
	P14.8	O0		General-purpose output
	TOUT88	O1		GTM output
	—	O2		Reserved
	—	O3		Reserved
	—	O4		Reserved
	—	O5		Reserved
—	O6	Reserved		
—	O7	Reserved		
C19	P14.9	I	MP+ / PU1 / VEXT	General-purpose input
	TIN89			GTM input
	ACTS0A			ASCLIN0 input
	P14.9	O0		General-purpose output
	TOUT89	O1		GTM output
	END03	O2		MSC0 output
	EN01	O3		MSC0 output
	—	O4		Reserved
	$\overline{\text{TXEN0B}}$	O5		ERAY0 output
	$\overline{\text{TXEN0A}}$	O6		ERAY0 output
	$\overline{\text{TXEN1A}}$	O7		ERAY1 output

Package and Pinning Definitions TC298x Pin Definition and Functions:

Table 2-34 Port 14 Functions (cont'd)

Pin	Symbol	Ctrl	Type	Function
C15	P14.10	I	MP+ / PU1 / VEXT	General-purpose input
	TIN90			GTM input
	P14.10	O0		General-purpose output
	TOUT90	O1		GTM output
	END02	O2		MSC0 output
	EN00	O3		MSC0 output
	ATX1	O4		ASCLIN1 output
	TXDCAN2	O5		CAN node 2 output
	TXD0A	O6		ERAY0 output
	TXD1A	O7		ERAY1 output
A19	P14.11	I	LP / PU1 / VEXT	General-purpose input
	TIN258			GTM input
	P14.11	O0		General-purpose output
	TOUT258	O1		GTM output
	END20	O2		MSC2 output
	PSITX4	O3		PSI5 output
	EN22	O4		MSC2 output
	SOP2	O5		MSC2 output
	-	O6		Reserved
	-	O7		Reserved
A15	P14.12	I	LP / PU1 / VEXT	General-purpose input
	TIN261			GTM input
	SDI20			MSC2 input
	P14.12	O0		General-purpose output
	TOUT261	O1		GTM output
	-	O2		Reserved
	-	O3		Reserved
	-	O4		Reserved
	-	O5		Reserved
	-	O6		Reserved
-	O7	Reserved		

Package and Pinning Definitions TC298x Pin Definition and Functions:

Table 2-34 Port 14 Functions (cont'd)

Pin	Symbol	Ctrl	Type	Function
B19	P14.13	I	MP+ / PU1 / VEXT	General-purpose input
	TIN260			GTM input
	P14.13	O0		General-purpose output
	TOUT260	O1		GTM output
	END23	O2		MSC2 output
	–	O3		Reserved
	EN21	O4		MSC2 output
	–	O5		Reserved
	–	O6		Reserved
	–	O7		Reserved
B15	P14.14	I	MP+ / PU1 / VEXT	General-purpose input
	TIN259			GTM input
	P14.14	O0		General-purpose output
	TOUT259	O1		GTM output
	END22	O2		MSC2 output
	–	O3		Reserved
	EN20	O4		MSC2 output
	–	O5		Reserved
	–	O6		Reserved
	–	O7		Reserved
B14	P14.15	I	LP / PU1 / VEXT	General-purpose input
	TIN263			GTM input
	INJ21	O0		MSC2 output
	P14.15			General-purpose output
	TOUT263	O1		GTM output
	ATX1	O2		ASCLIN1 output
	–	O3		Reserved
	–	O4		Reserved
	–	O5		Reserved
	–	O6		Reserved
–	O7	Reserved		

Package and Pinning Definitions TC298x Pin Definition and Functions:

Table 2-35 Port 15 Functions

Pin	Symbol	Ctrl	Type	Function	
C22	P15.1	I	LP / PU1 / VEXT	General-purpose input	
	TIN72			GTM input	
	REQ16			SCU input	
	ARX1A			ASCLIN1 input	
	RXDCAN2A			CAN node 2 input	
	SLSI2B			QSPI2 input	
	EVRWUPB			SCU input	
	P15.1			O0	General-purpose output
	TOUT72	O1		GTM output	
	ATX1	O2		ASCLIN1 output	
	SLSO25	O3		QSPI2 output	
	–	O4		Reserved	
	–	O5		Reserved	
	–	O6		Reserved	
	–	O7		Reserved	
	B21	P15.2		I	MP / PU1 / VEXT
TIN73		GTM input			
SLSI2A		QSPI2 input			
MRST2E		QSPI2 input			
SENT10D		SENT input			
HSIC2INA		QSPI2 input			
P15.2		O0	General-purpose output		
TOUT73		O1	GTM output		
ATX0		O2	ASCLIN0 output		
SLSO20		O3	QSPI2 output		
–		O4	Reserved		
TXDCAN1		O5	CAN node 1 output		
ASCLK0		O6	ASCLIN0 output		
–		O7	Reserved		

Package and Pinning Definitions TC298x Pin Definition and Functions:

Table 2-35 Port 15 Functions (cont'd)

Pin	Symbol	Ctrl	Type	Function
D18	P15.3	I	MP / PU1 / VEXT	General-purpose input
	TIN74			GTM input
	ARX0B			ASCLIN0 input
	SCLK2A			QSPI2 input
	RXDCAN1A			CAN node 1 input
	HSIC2INB			QSPI2 input
	P15.3	O0		General-purpose output
	TOUT74	O1		GTM output
	ATX0	O2		ASCLIN0 output
	SCLK2	O3		QSPI2 output
	END03	O4		MSC0 output
	EN01	O5		MSC0 output
	—	O6		Reserved
	—	O7		Reserved
A21	P15.4	I	MP / PU1 / VEXT	General-purpose input
	TIN75			GTM input
	MRST2A			QSPI2 input
	REQ0			SCU input
	SCL0C			I2C0 input
	SENT11D			SENT input
	P15.4	O0		General-purpose output
	TOUT75	O1		GTM output
	ATX1	O2		ASCLIN1 output
	MRST2	O3		QSPI2 output
	—	O4		Reserved
	—	O5		Reserved
	SCL0	O6		I2C0 output
	CC62	O7		CCU60 output

Package and Pinning Definitions TC298x Pin Definition and Functions:

Table 2-35 Port 15 Functions (cont'd)

Pin	Symbol	Ctrl	Type	Function
D19	P15.5	I	MP / PU1 / VEXT	General-purpose input
	TIN76			GTM input
	ARX1B			ASCLIN1 input
	MTSR2A			QSPI2 input
	REQ13			SCU input
	SDA0C			I2C0 input
	P15.5			O0
	TOUT76	O1		GTM output
	ATX1	O2		ASCLIN1 output
	MTSR2	O3		QSPI2 output
	END02	O4		MSC0 output
	EN00	O5		MSC0 output
	SDA0	O6		I2C0 output
	CC61	O7		CCU60 output
B20	P15.6	I	MP / PU1 / VEXT	General-purpose input
	TIN77			GTM input
	MTSR2B			QSPI2 input
	P15.6	O0		General-purpose output
	TOUT77	O1		GTM output
	ATX3	O2		ASCLIN3 output
	MTSR2	O3		QSPI2 output
	SLSO53	O4		QSPI5 output
	SCLK2	O5		QSPI2 output
	ASCLK3	O6		ASCLIN3 output
CC60	O7	CCU60 output		
A20	P15.7	I	MP / PU1 / VEXT	General-purpose input
	TIN78			GTM input
	ARX3A			ASCLIN3 input
	MRST2B			QSPI2 input
	P15.7	O0		General-purpose output
	TOUT78	O1		GTM output
	ATX3	O2		ASCLIN3 output
	MRST2	O3		QSPI2 output
	—	O4		Reserved
	—	O5		Reserved
	—	O6		Reserved
	COUT60	O7		CCU60 output

Package and Pinning Definitions TC298x Pin Definition and Functions:

Table 2-35 Port 15 Functions (cont'd)

Pin	Symbol	Ctrl	Type	Function
D16	P15.8	I	MP / PU1 / VEXT	General-purpose input
	TIN79			GTM input
	SCLK2B			QSPI2 input
	REQ1			SCU input
	P15.8	O0		General-purpose output
	TOUT79	O1		GTM output
	–	O2		Reserved
	SCLK2	O3		QSPI2 output
	–	O4		Reserved
	–	O5		Reserved
	ASCLK3	O6		ASCLIN3 output
	COU61	O7		CCU60 output

Table 2-36 Port 20 Functions

Pin	Symbol	Ctrl	Type	Function
A24	P20.0	I	MP / PU1 / VEXT	General-purpose input
	TIN59			GTM input
	RXDCAN3C			CAN node 3 input
	RXDCANr1C			CAN node 1 input (MultiCANr+)
	T6EUDA			GPT120 input
	REQ9			SCU input
	SYSCLK			HSCT input
	TGI0			OCDS input
	P20.0			O0
	TOUT59	O1		GTM output
	ATX3	O2		ASCLIN3 output
	ASCLK3	O3		ASCLIN3 output
	–	O4		Reserved
	SYSCLK	O5		HSCT output
	–	O6		Reserved
	–	O7		Reserved
	TGO0	HWOUT		OCDS; ENx

Package and Pinning Definitions TC298x Pin Definition and Functions:
Table 2-36 Port 20 Functions (cont'd)

Pin	Symbol	Ctrl	Type	Function
B23	P20.2	I	LP / PU1 / VEXT	General-purpose input This pin is latched at power on reset release to enter test mode.
	$\overline{\text{TESTMODE}}$			OCDS input
	P20.2	O0		Output function not available
	—	O1		Output function not available
	—	O2		Output function not available
	—	O3		Output function not available
	—	O4		Output function not available
	—	O5		Output function not available
	—	O6		Output function not available
	—	O7		Output function not available

Table 2-37 Port 21 Functions

Pin	Symbol	Ctrl	Type	Function
J23	P21.0	I	LVDSH_N/ PU1 / VDDP3	General-purpose input
	TIN51			GTM input
	MRST4DN			QSPI4 input (LVDS)
	HOLD			EBU input
	P21.0	O0		General-purpose output
	TOUT51	O1		GTM output
	—	O2		Reserved
	—	O3		Reserved
	—	O4		Reserved
	—	O5		Reserved
	ETHMDC	O6		ETH output
	BAABA0	O7		EBU output (combined for BAA and BA0)
	HSM1	O		HSM output

Package and Pinning Definitions TC298x Pin Definition and Functions:

Table 2-37 Port 21 Functions (cont'd)

Pin	Symbol	Ctrl	Type	Function
G24	P21.1	I	LVDSH_P/ PU1 / VDDP3	General-purpose input
	TIN52			GTM input
	ETHMDIOB			ETH input (Not for production purposes)
	MRST4DP			QSPI4 input (LVDS)
	WAIT			EBU input
	P21.1	O0		General-purpose output
	TOUT52	O1		GTM output
	–	O2		Reserved
	–	O3		Reserved
	–	O4		Reserved
	–	O5		Reserved
	ETHMDIO	O6		ETH output (Not for production purposes)
	BREQBA1	O7		EBU output (combined for BREQ and BA1)
	HSM2	O		HSM output
H23	P21.2	I	LVDSH_N/ PU1 / VDDP3	General-purpose input
	TIN53			GTM input
	MRST2CN			QSPI2 input (LVDS)
	MRST4CN			QSPI4 input (LVDS)
	ARX3GN			ASCLIN3 input (LVDS)
	EMGSTOPB			SCU input
	RXDN			H SCT input (LVDS)
	P21.2	O0		General-purpose output
	TOUT53	O1		GTM output
	ASLSO3	O2		ASCLIN3 output
	–	O3		Reserved
	–	O4		Reserved
	ETHMDC	O5		ETH output
	SDRAMA8	O6		EBU output
–	O7	Reserved		

Package and Pinning Definitions TC298x Pin Definition and Functions:

Table 2-37 Port 21 Functions (cont'd)

Pin	Symbol	Ctrl	Type	Function
G23	P21.3	I	LVDSH_P/ PU1 / VDDP3	General-purpose input
	TIN54			GTM input
	MRST2CP			QSPI2 input (LVDS)
	MRST4CP			QSPI4 input (LVDS)
	ARX3GP			ASCLIN3 input (LVDS)
	RXDP			HSCT input (LVDS)
	P21.3	O0		General-purpose output
	TOUT54	O1		GTM output
	–	O2		Reserved
	–	O3		Reserved
	–	O4		Reserved
	–	O5		Reserved
	SDRAMA9	O6		EBU output
	–	O7		Reserved
ETHMDIOD	HWOUT	ETH input/output		
D26	P21.4	I	LVDSH_N/ PU1 / VDDP3	General-purpose input
	TIN55			GTM input
	P21.4	O0		General-purpose output
	TOUT55	O1		GTM output
	–	O2		Reserved
	–	O3		Reserved
	–	O4		Reserved
	–	O5		Reserved
	SDRAMA10	O6		EBU output
	–	O7		Reserved
	TXDN	HSCT		HSCT output (LVDS)
C26	P21.5	I	LVDSH_P/ PU1 / VDDP3	General-purpose input
	TIN56			GTM input
	P21.5	O0		General-purpose output
	TOUT56	O1		GTM output
	ASCLK3	O2		ASCLIN3 output
	–	O3		Reserved
	–	O4		Reserved
	–	O5		Reserved
	SDRAMA11	O6		EBU output
	–	O7		Reserved
	TXDP	HSCT		HSCT output (LVDS)

Package and Pinning Definitions TC298x Pin Definition and Functions:
Table 2-37 Port 21 Functions (cont'd)

Pin	Symbol	Ctrl	Type	Function
E25	P21.6	I	A2 / PU / VDDP3	General-purpose input
	TIN57			GTM input
	ARX3F			ASCLIN3 input
	TGI2			OCDS input
	TDI			OCDS (JTAG) input
	T5EUDA			GPT120 input
	P21.6			O0
	TOUT57	O1		GTM output
	ASLSO3	O2		ASCLIN3 output
	–	O3		Reserved
	–	O4		Reserved
	SYCLK	O5		H SCT output
	SDRAMA12	O6		EBU output
	T3OUT	O7		GPT120 output
	TGO2	HWOUT		OCDS; ENx
D25	P21.7	I	A2 / PU / VDDP3	General-purpose input
	TIN58			GTM input
	DAP2			OCDS (3-Pin DAP) input In the 3-Pin DAP mode this pin is used as DAP2. In the 2-PIN DAP mode this pin is used as P21.7 and controlled by the related port control logic
	TGI3			OCDS input
	ETHRXERB			ETH input
	T5INA			GPT120 input
	P21.7			O0
	TOUT58	O1		GTM output
	ATX3	O2		ASCLIN3 output
	ASCLK3	O3		ASCLIN3 output
	–	O4		Reserved
	–	O5		Reserved
	SDRAMA13	O6		EBU output
	T6OUT	O7		GPT120 output
	TGO3	HWOUT		OCDS; ENx
	TDO			OCDS (JTAG); ENx The JTAG TDO function is overlaid with P21.7 via a double bond. In JTAG mode this pin is used as TDO, after power-on reset it is HighZ.
	DAP2			OCDS (3-Pin DAP); ENx In the 3-Pin DAP mode this pin is used as DAP2.

Package and Pinning Definitions TC298x Pin Definition and Functions:

Table 2-38 Port 22 Functions

Pin	Symbol	Ctrl	Type	Function
K23	P22.0	I	LVDSM_N / PU1 / VEXT	General-purpose input
	TIN47			GTM input
	M TSR4B			QSPI4 input
	P22.0	O0		General-purpose output
	TOUT47	O1		GTM output
	ATX3N	O2		ASCLIN3 output (LVDS)
	M TSR4	O3		QSPI4 output
	SCLK4N	O4		QSPI4 output (LVDS)
	FCLN1	O5		MSC1 output (LVDS)
	FCLND1	O6		MSC1 output (LVDS)
	–	O7		Reserved
J24	P22.1	I	LVDSM_P / PU1 / VEXT	General-purpose input
	TIN48			GTM input
	M RST4B			QSPI4 input
	P22.1	O0		General-purpose output
	TOUT48	O1		GTM output
	ATX3P	O2		ASCLIN3 output (LVDS)
	M RST4	O3		QSPI4 output
	SCLK4P	O4		QSPI4 output (LVDS)
	FCLP1	O5		MSC1 output (LVDS)
	–	O6		Reserved
	–	O7		Reserved
J25	P22.2	I	LVDSM_N / PU1 / VEXT	General-purpose input
	TIN49			GTM input
	SLSI4B			QSPI4 input
	P22.2	O0		General-purpose output
	TOUT49	O1		GTM output
	–	O2		Reserved
	SLSO43	O3		QSPI4 output
	M TSR4N	O4		QSPI4 output (LVDS)
	SON1	O5		MSC1 output (LVDS)
	SOND1	O6		MSC1 output (LVDS)
	–	O7		Reserved

Package and Pinning Definitions TC298x Pin Definition and Functions:

Table 2-38 Port 22 Functions (cont'd)

Pin	Symbol	Ctrl	Type	Function
J26	P22.3	I	LVDSM_P / PU1 / VEXT	General-purpose input
	TIN50			GTM input
	SCLK4B			QSPI4 input
	P22.3	O0		General-purpose output
	TOUT50	O1		GTM output
	–	O2		Reserved
	SCLK4	O3		QSPI4 output
	MTSR4P	O4		QSPI4 output (LVDS)
	SOP1	O5		MSC1 output (LVDS)
	–	O6		Reserved
	–	O7		Reserved

Table 2-39 Port 23 Functions

Pin	Symbol	Ctrl	Type	Function
M26	P23.0	I	LP / PU1 / VEXT	General-purpose input
	TIN41			GTM input
	P23.0	O0		General-purpose output
	TOUT41	O1		GTM output
	–	O2		Reserved
	–	O3		Reserved
	–	O4		Reserved
	–	O5		Reserved
	–	O6		Reserved
	–	O7		Reserved
L24	P23.1	I	MP+ / PU1 / VEXT	General-purpose input
	TIN42			GTM input
	SDI10			MSC1 input
	P23.1	O0		General-purpose output
	TOUT42	O1		GTM output
	ARTS1	O2		ASCLIN1 output
	SLSO46	O3		QSPI4 output
	GTMCLK0	O4		GTM output
	–	O5		Reserved
	EXTCLK0	O6		SCU output
	–	O7		Reserved

Package and Pinning Definitions TC298x Pin Definition and Functions:

Table 2-39 Port 23 Functions (cont'd)

Pin	Symbol	Ctrl	Type	Function
L25	P23.2	I	LP / PU1 / VEXT	General-purpose input
	TIN43			GTM input
	P23.2	O0		General-purpose output
	TOUT43	O1		GTM output
	—	O2		Reserved
	—	O3		Reserved
	—	O4		Reserved
	—	O5		Reserved
	—	O6		Reserved
	—	O7		Reserved
L26	P23.3	I	LP / PU1 / VEXT	General-purpose input
	TIN44			GTM input
	INJ10			MSC1 input
	P23.3	O0		General-purpose output
	TOUT44	O1		GTM output
	—	O2		Reserved
	—	O3		Reserved
	—	O4		Reserved
	—	O5		Reserved
	—	O6		Reserved
—	O7	Reserved		
K24	P23.4	I	MP+ / PU1 / VEXT	General-purpose input
	TIN45			GTM input
	P23.4	O0		General-purpose output
	TOUT45	O1		GTM output
	—	O2		Reserved
	SLSO45	O3		QSPI4 output
	END12	O4		MSC1 output
	EN10	O5		MSC1 output
	—	O6		Reserved
	—	O7		Reserved

Package and Pinning Definitions TC298x Pin Definition and Functions:
Table 2-39 Port 23 Functions (cont'd)

Pin	Symbol	Ctrl	Type	Function
K25	P23.5	I	MP+ / PU1 / VEXT	General-purpose input
	TIN46			GTM input
	P23.5	O0		General-purpose output
	TOUT46	O1		GTM output
	—	O2		Reserved
	SLSO44	O3		QSPI4 output
	END13	O4		MSC1 output
	EN11	O5		MSC1 output
	—	O6		Reserved
	—	O7		Reserved
K26	P23.6	I	LP / PU1 / VEXT	General-purpose input
	TIN138			GTM input
	P23.6	O0		General-purpose output
	TOUT138	O1		GTM output
	—	O2		Reserved
	—	O3		Reserved
	SLSO011	O4		QSPI0 output
	—	O5		Reserved
	—	O6		Reserved
	—	O7		Reserved

Table 2-40 Port 24 Functions

Pin	Symbol	Ctrl	Type	Function
U23	P24.0	I	A2 / PU1 / VEBU	General-purpose input
	TIN222			GTM input
	P24.0	O0		General-purpose output
	TOUT222	O1		GTM output
	—	O2		Reserved
	—	O3		Reserved
	—	O4		Reserved
	—	O5		Reserved
	—	O6		Reserved
	—	O7		Reserved
	DQ11	HWOU		EBU Data Bus Line (SDRAM)
	A11	T		EBU output

Package and Pinning Definitions TC298x Pin Definition and Functions:

Table 2-40 Port 24 Functions (cont'd)

Pin	Symbol	Ctrl	Type	Function
T24	P24.1	I	A2 / PU1 / VEBU	General-purpose input
	TIN223			GTM input
	P24.1	O0		General-purpose output
	TOUT223	O1		GTM output
	—	O2		Reserved
	—	O3		Reserved
	—	O4		Reserved
	—	O5		Reserved
	—	O6		Reserved
	—	O7		Reserved
	DQ15	HWOU		EBU Data Bus Line (SDRAM)
	A15	T		EBU output
T25	P24.2	I	A2 / PU1 / VEBU	General-purpose input
	TIN224			GTM input
	P24.2	O0		General-purpose output
	TOUT224	O1		GTM output
	—	O2		Reserved
	—	O3		Reserved
	—	O4		Reserved
	—	O5		Reserved
	—	O6		Reserved
	—	O7		Reserved
	DQ14	HWOU		EBU Data Bus Line (SDRAM)
	A14	T		EBU output
T26	P24.3	I	A2 / PU1 / VEBU	General-purpose input
	TIN225			GTM input
	P24.3	O0		General-purpose output
	TOUT225	O1		GTM output
	—	O2		Reserved
	—	O3		Reserved
	—	O4		Reserved
	—	O5		Reserved
	—	O6		Reserved
	—	O7		Reserved
	DQ13	HWOU		EBU Data Bus Line (SDRAM)
	A13	T		EBU output

Package and Pinning Definitions TC298x Pin Definition and Functions:

Table 2-40 Port 24 Functions (cont'd)

Pin	Symbol	Ctrl	Type	Function
R24	P24.4	I	A2 / PU1 / VEBU	General-purpose input
	TIN226			GTM input
	P24.4	O0		General-purpose output
	TOUT226	O1		GTM output
	—	O2		Reserved
	—	O3		Reserved
	—	O4		Reserved
	—	O5		Reserved
	—	O6		Reserved
	—	O7		Reserved
	DQ9	HWOU		EBU Data Bus Line (SDRAM)
	A9	T		EBU output
R25	P24.5	I	A2 / PU1 / VEBU	General-purpose input
	TIN227			GTM input
	P24.5	O0		General-purpose output
	TOUT227	O1		GTM output
	—	O2		Reserved
	—	O3		Reserved
	—	O4		Reserved
	—	O5		Reserved
	—	O6		Reserved
	—	O7		Reserved
	DQ12	HWOU		EBU Data Bus Line (SDRAM)
	A12	T		EBU output
R26	P24.6	I	A2 / PU1 / VEBU	General-purpose input
	TIN228			GTM input
	P24.6	O0		General-purpose output
	TOUT228	O1		GTM output
	—	O2		Reserved
	—	O3		Reserved
	—	O4		Reserved
	—	O5		Reserved
	—	O6		Reserved
	—	O7		Reserved
	DQ5	HWOU		EBU Data Bus Line (SDRAM)
	A5	T		EBU output

Package and Pinning Definitions TC298x Pin Definition and Functions:

Table 2-40 Port 24 Functions (cont'd)

Pin	Symbol	Ctrl	Type	Function
P24	P24.7	I	A2 / PU1 / VEBU	General-purpose input
	TIN229			GTM input
	P24.7	O0		General-purpose output
	TOUT229	O1		GTM output
	—	O2		Reserved
	—	O3		Reserved
	—	O4		Reserved
	—	O5		Reserved
	—	O6		Reserved
	—	O7		Reserved
	DQ8	HWOU		EBU Data Bus Line (SDRAM)
	A8	T		EBU output
P25	P24.8	I	A2 / PU1 / VEBU	General-purpose input
	TIN230			GTM input
	P24.8	O0		General-purpose output
	TOUT230	O1		GTM output
	—	O2		Reserved
	—	O3		Reserved
	—	O4		Reserved
	—	O5		Reserved
	—	O6		Reserved
	—	O7		Reserved
	DQ10	HWOU		EBU Data Bus Line (SDRAM)
	A10	T		EBU output
P26	P24.9	I	A2 / PU1 / VEBU	General-purpose input
	TIN231			GTM input
	P24.9	O0		General-purpose output
	TOUT231	O1		GTM output
	—	O2		Reserved
	—	O3		Reserved
	—	O4		Reserved
	—	O5		Reserved
	—	O6		Reserved
	—	O7		Reserved
	DQ6	HWOU		EBU Data Bus Line (SDRAM)
	A6	T		EBU output

Package and Pinning Definitions TC298x Pin Definition and Functions:
Table 2-40 Port 24 Functions (cont'd)

Pin	Symbol	Ctrl	Type	Function
N23	P24.10	I	A2 / PU1 / VEBU	General-purpose input
	TIN232			GTM input
	P24.10	O0		General-purpose output
	TOUT232	O1		GTM output
	—	O2		Reserved
	—	O3		Reserved
	—	O4		Reserved
	—	O5		Reserved
	—	O6		Reserved
	—	O7		Reserved
	DQ4	HWOU T		EBU Data Bus Line (SDRAM)
	A4			EBU output
N24	P24.11	I	A2 / PU1 / VEBU	General-purpose input
	TIN233			GTM input
	P24.11	O0		General-purpose output
	TOUT233	O1		GTM output
	—	O2		Reserved
	—	O3		Reserved
	—	O4		Reserved
	—	O5		Reserved
	—	O6		Reserved
	—	O7		Reserved
	DQ3	HWOU T		EBU Data Bus Line (SDRAM)
	A3			EBU output
N25	P24.12	I	A2 / PU1 / VEBU	General-purpose input
	TIN234			GTM input
	P24.12	O0		General-purpose output
	TOUT234	O1		GTM output
	—	O2		Reserved
	—	O3		Reserved
	—	O4		Reserved
	—	O5		Reserved
	—	O6		Reserved
	—	O7		Reserved
	DQ1	HWOU T		EBU Data Bus Line (SDRAM)
	A1			EBU output

Package and Pinning Definitions TC298x Pin Definition and Functions:

Table 2-40 Port 24 Functions (cont'd)

Pin	Symbol	Ctrl	Type	Function
N26	P24.13	I	A2 / PU1 / VEBU	General-purpose input
	TIN235			GTM input
	P24.13	O0		General-purpose output
	TOUT235	O1		GTM output
	—	O2		Reserved
	—	O3		Reserved
	—	O4		Reserved
	—	O5		Reserved
	—	O6		Reserved
	—	O7		Reserved
	DQ2	HWOU		EBU Data Bus Line (SDRAM)
	A2	T		EBU output
M24	P24.14	I	A2 / PU1 / VEBU	General-purpose input
	TIN236			GTM input
	P24.14	O0		General-purpose output
	TOUT236	O1		GTM output
	—	O2		Reserved
	—	O3		Reserved
	—	O4		Reserved
	—	O5		Reserved
	—	O6		Reserved
	—	O7		Reserved
	DQ0	HWOU		EBU Data Bus Line (SDRAM)
	A0	T		EBU output
M25	P24.15	I	A2 / PU1 / VEBU	General-purpose input
	TIN237			GTM input
	P24.15	O0		General-purpose output
	TOUT237	O1		GTM output
	—	O2		Reserved
	—	O3		Reserved
	—	O4		Reserved
	—	O5		Reserved
	—	O6		Reserved
	—	O7		Reserved
	DQ7	HWOU		EBU Data Bus Line (SDRAM)
	A7	T		EBU output

Package and Pinning Definitions TC298x Pin Definition and Functions:

Table 2-41 Port 25 Functions

Pin	Symbol	Ctrl	Type	Function
AA26	P25.0	I	A2 / PU1 / VEBU	General-purpose input
	TIN206			GTM input
	SDCLKI			EBU input
	P25.0	O0		General-purpose output
	TOUT206	O1		GTM output
	—	O2		Reserved
	—	O3		Reserved
	—	O4		Reserved
	—	O5		Reserved
	—	O6		Reserved
	—	O7		Reserved
	BFCLKO	HWOU		EBU output
	SDCLKO	T		EBU output
AA24	P25.1	I	A2 / PU1 / VEBU	General-purpose input
	TIN207			GTM input
	P25.1			General-purpose output
	TOUT207	O1		GTM output
	—	O2		Reserved
	—	O3		Reserved
	—	O4		Reserved
	—	O5		Reserved
	—	O6		Reserved
	—	O7		Reserved
	$\overline{\text{RD}}$	HWOU		EBU output
	$\overline{\text{RAS}}$	T		EBU output
	AA23	P25.2		I
TIN208		GTM input		
P25.2		General-purpose output		
TOUT208		O1	GTM output	
—		O2	Reserved	
—		O3	Reserved	
—		O4	Reserved	
—		O5	Reserved	
—		O6	Reserved	
—		O7	Reserved	
$\overline{\text{RD}}/\overline{\text{WR}}$		HWOU	EBU output	
$\overline{\text{WR}}$		T	EBU output	

Package and Pinning Definitions TC298x Pin Definition and Functions:

Table 2-41 Port 25 Functions (cont'd)

Pin	Symbol	Ctrl	Type	Function
Y24	P25.3	I	A2 / PU1 / VEBU	General-purpose input
	TIN209			GTM input
	HOLDA			EBU input
	P25.3	O0		General-purpose output
	TOUT209	O1		GTM output
	—	O2		Reserved
	—	O3		Reserved
	—	O4		Reserved
	—	O5		Reserved
	—	O6		Reserved
	BAABA0	O7		EBU output (combined for BAA and BA0)
	CS2	HWOU T		EBU output
	DQM1			EBU output
	HOLDA			EBU output
Y25	P25.4	I	A2 / PU1 / VEBU	General-purpose input
	TIN210			GTM input
	P25.4	O0		General-purpose output
	TOUT210	O1		GTM output
	—	O2		Reserved
	—	O3		Reserved
	—	O4		Reserved
	—	O5		Reserved
	—	O6		Reserved
	—	O7		Reserved
	CS1	HWOU T		EBU output
DQM0	EBU output			
Y26	P25.5	I	A2 / PU1 / VEBU	General-purpose input
	TIN211			GTM input
	P25.5	O0		General-purpose output
	TOUT211	O1		GTM output
	—	O2		Reserved
	—	O3		Reserved
	—	O4		Reserved
	—	O5		Reserved
	—	O6		Reserved
	—	O7		Reserved
	CS0	HWOU T		EBU output

Package and Pinning Definitions TC298x Pin Definition and Functions:

Table 2-41 Port 25 Functions (cont'd)

Pin	Symbol	Ctrl	Type	Function
W24	P25.7	I	A2 / PU1 / VEBU	General-purpose input
	TIN213			GTM input
	P25.7	O0		General-purpose output
	TOUT213	O1		GTM output
	—	O2		Reserved
	—	O3		Reserved
	—	O4		Reserved
	—	O5		Reserved
	—	O6		Reserved
	—	O7		Reserved
	ADV	HWOU		EBU output
	CAS	T		EBU output
W25	P25.8	I	A2 / PU1 / VEBU	General-purpose input
	TIN214			GTM input
	P25.8	O0		General-purpose output
	TOUT214	O1		GTM output
	—	O2		Reserved
	—	O3		Reserved
	—	O4		Reserved
	A23	O5		EBU output
	SDRAMA0	O6		EBU output
	—	O7		Reserved
	BC0	HWOU T		EBU output
W26	P25.9	I	A2 / PU1 / VEBU	General-purpose input
	TIN215			GTM input
	P25.9	O0		General-purpose output
	TOUT215	O1		GTM output
	—	O2		Reserved
	—	O3		Reserved
	—	O4		Reserved
	A22	O5		EBU output
	SDRAMA1	O6		EBU output
	—	O7		Reserved
	BC1	HWOU T		EBU output

Package and Pinning Definitions TC298x Pin Definition and Functions:

Table 2-41 Port 25 Functions (cont'd)

Pin	Symbol	Ctrl	Type	Function
V24	P25.10	I	A2 / PU1 / VEBU	General-purpose input
	TIN216			GTM input
	P25.10	O0		General-purpose output
	TOUT216	O1		GTM output
	—	O2		Reserved
	—	O3		Reserved
	—	O4		Reserved
	A21	O5		EBU output
	SDRAMA2	O6		EBU output
	—	O7		Reserved
	BC2	HWOUT		EBU output
V25	P25.11	I	A2 / PU1 / VEBU	General-purpose input
	TIN217			GTM input
	P25.11	O0		General-purpose output
	TOUT217	O1		GTM output
	—	O2		Reserved
	—	O3		Reserved
	—	O4		Reserved
	A20	O5		EBU output
	SDRAMA3	O6		EBU output
	—	O7		Reserved
	BC3	HWOUT		EBU output
V26	P25.12	I	A2 / PU1 / VEBU	General-purpose input
	TIN218			GTM input
	P25.12	O0		General-purpose output
	TOUT218	O1		GTM output
	—	O2		Reserved
	—	O3		Reserved
	—	O4		Reserved
	—	O5		Reserved
	SDRAMA4	O6		EBU output
	—	O7		Reserved
	A19	HWOUT		EBU output

Package and Pinning Definitions TC298x Pin Definition and Functions:

Table 2-41 Port 25 Functions (cont'd)

Pin	Symbol	Ctrl	Type	Function
U24	P25.13	I	A2 / PU1 / VEBU	General-purpose input
	TIN219			GTM input
	P25.13	O0		General-purpose output
	TOUT219	O1		GTM output
	—	O2		Reserved
	—	O3		Reserved
	—	O4		Reserved
	—	O5		Reserved
	SDRAMA5	O6		EBU output
	—	O7		Reserved
A17	HWOUT	EBU output		
U25	P25.14	I	A2 / PU1 / VEBU	General-purpose input
	TIN220			GTM input
	P25.14	O0		General-purpose output
	TOUT220	O1		GTM output
	—	O2		Reserved
	—	O3		Reserved
	—	O4		Reserved
	—	O5		Reserved
	SDRAMA6	O6		EBU output
	—	O7		Reserved
A18	HWOUT	EBU output		
U26	P25.15	I	A2 / PU1 / VEBU	General-purpose input
	TIN221			GTM input
	P25.15	O0		General-purpose output
	TOUT221	O1		GTM output
	—	O2		Reserved
	—	O3		Reserved
	—	O4		Reserved
	—	O5		Reserved
	SDRAMA7	O6		EBU output
	—	O7		Reserved
A16	HWOUT	EBU output		

Package and Pinning Definitions TC298x Pin Definition and Functions:

Table 2-42 Port 26 Functions

Pin	Symbol	Ctrl	Type	Function
AA25	P26.0	I	LP / PU1 / VFLEXE	General-purpose input
	TIN212			GTM input
	BFCLKI			EBU input
	P26.0	O0		General-purpose output
	TOUT212	O1		GTM output
	—	O2		Reserved
	—	O3		Reserved
	—	O4		Reserved
	—	O5		Reserved
	—	O6		Reserved
	—	O7		Reserved

Table 2-43 Port 30 Functions

Pin	Symbol	Ctrl	Type	Function
AF22	P30.0	I	MP / PU1 / VFLEXE	General-purpose input
	TIN190			GTM input
	P30.0			O0
	TOUT190	O1		GTM output
	—	O2		Reserved
	—	O3		Reserved
	—	O4		Reserved
	—	O5		Reserved
	—	O6		Reserved
	—	O7		Reserved
		AD14		HWOUT
AF23	P30.1	I	MP / PU1 / VFLEXE	General-purpose input
	TIN191			GTM input
	P30.1			O0
	TOUT191	O1		GTM output
	—	O2		Reserved
	—	O3		Reserved
	—	O4		Reserved
	—	O5		Reserved
	—	O6		Reserved
	—	O7		Reserved
		AD11		HWOUT

Package and Pinning Definitions TC298x Pin Definition and Functions:
Table 2-43 Port 30 Functions (cont'd)

Pin	Symbol	Ctrl	Type	Function
AB24	P30.2	I	MP / PU1 / VFLEXE	General-purpose input
	TIN192			GTM input
	P30.2	O0		General-purpose output
	TOUT192	O1		GTM output
	—	O2		Reserved
	—	O3		Reserved
	—	O4		Reserved
	—	O5		Reserved
	—	O6		Reserved
	—	O7		Reserved
	AD12	HWOUT		EBU Address / Data Bus Line
AC24	P30.3	I	MP / PU1 / VFLEXE	General-purpose input
	TIN193			GTM input
	P30.3	O0		General-purpose output
	TOUT193	O1		GTM output
	—	O2		Reserved
	—	O3		Reserved
	—	O4		Reserved
	—	O5		Reserved
	—	O6		Reserved
	—	O7		Reserved
	AD15	HWOUT		EBU Address / Data Bus Line
AD24	P30.4	I	MP / PU1 / VFLEXE	General-purpose input
	TIN194			GTM input
	P30.4	O0		General-purpose output
	TOUT194	O1		GTM output
	—	O2		Reserved
	—	O3		Reserved
	—	O4		Reserved
	—	O5		Reserved
	—	O6		Reserved
	—	O7		Reserved
	AD8	HWOUT		EBU Address / Data Bus Line

Package and Pinning Definitions TC298x Pin Definition and Functions:
Table 2-43 Port 30 Functions (cont'd)

Pin	Symbol	Ctrl	Type	Function
AE24	P30.5	I	MP / PU1 / VFLEXE	General-purpose input
	TIN195			GTM input
	P30.5	O0		General-purpose output
	TOUT195	O1		GTM output
	—	O2		Reserved
	—	O3		Reserved
	—	O4		Reserved
	—	O5		Reserved
	—	O6		Reserved
	—	O7		Reserved
	AD13	HWOUT		EBU Address / Data Bus Line
AF24	P30.6	I	MP / PU1 / VFLEXE	General-purpose input
	TIN196			GTM input
	P30.6	O0		General-purpose output
	TOUT196	O1		GTM output
	—	O2		Reserved
	—	O3		Reserved
	—	O4		Reserved
	—	O5		Reserved
	—	O6		Reserved
	—	O7		Reserved
	AD4	HWOUT		EBU Address / Data Bus Line
AB25	P30.7	I	MP / PU1 / VFLEXE	General-purpose input
	TIN197			GTM input
	P30.7	O0		General-purpose output
	TOUT197	O1		GTM output
	—	O2		Reserved
	—	O3		Reserved
	—	O4		Reserved
	—	O5		Reserved
	—	O6		Reserved
	—	O7		Reserved
	AD7	HWOUT		EBU Address / Data Bus Line

Package and Pinning Definitions TC298x Pin Definition and Functions:
Table 2-43 Port 30 Functions (cont'd)

Pin	Symbol	Ctrl	Type	Function
AC25	P30.8	I	MP / PU1 / VFLEXE	General-purpose input
	TIN198			GTM input
	P30.8	O0		General-purpose output
	TOUT198	O1		GTM output
	—	O2		Reserved
	—	O3		Reserved
	—	O4		Reserved
	—	O5		Reserved
	—	O6		Reserved
	—	O7		Reserved
	AD3	HWOUT		EBU Address / Data Bus Line
AD25	P30.9	I	MP / PU1 / VFLEXE	General-purpose input
	TIN199			GTM input
	P30.9	O0		General-purpose output
	TOUT199	O1		GTM output
	—	O2		Reserved
	—	O3		Reserved
	—	O4		Reserved
	—	O5		Reserved
	—	O6		Reserved
	—	O7		Reserved
	AD0	HWOUT		EBU Address / Data Bus Line
AE25	P30.10	I	MP / PU1 / VFLEXE	General-purpose input
	TIN200			GTM input
	P30.10	O0		General-purpose output
	TOUT200	O1		GTM output
	—	O2		Reserved
	—	O3		Reserved
	—	O4		Reserved
	—	O5		Reserved
	—	O6		Reserved
	—	O7		Reserved
	AD5	HWOUT		EBU Address / Data Bus Line

Package and Pinning Definitions TC298x Pin Definition and Functions:
Table 2-43 Port 30 Functions (cont'd)

Pin	Symbol	Ctrl	Type	Function
AF25	P30.11	I	MP / PU1 / VFLEXE	General-purpose input
	TIN201			GTM input
	P30.11	O0		General-purpose output
	TOUT201	O1		GTM output
	—	O2		Reserved
	—	O3		Reserved
	—	O4		Reserved
	—	O5		Reserved
	—	O6		Reserved
	—	O7		Reserved
	AD10	HWOUT		EBU Address / Data Bus Line
AB26	P30.12	I	MP / PU1 / VFLEXE	General-purpose input
	TIN202			GTM input
	P30.12	O0		General-purpose output
	TOUT202	O1		GTM output
	—	O2		Reserved
	—	O3		Reserved
	—	O4		Reserved
	—	O5		Reserved
	—	O6		Reserved
	—	O7		Reserved
	AD9	HWOUT		EBU Address / Data Bus Line
AC26	P30.13	I	MP / PU1 / VFLEXE	General-purpose input
	TIN203			GTM input
	P30.13	O0		General-purpose output
	TOUT203	O1		GTM output
	—	O2		Reserved
	—	O3		Reserved
	—	O4		Reserved
	—	O5		Reserved
	—	O6		Reserved
	—	O7		Reserved
	AD2	HWOUT		EBU Address / Data Bus Line

Package and Pinning Definitions TC298x Pin Definition and Functions:

Table 2-43 Port 30 Functions (cont'd)

Pin	Symbol	Ctrl	Type	Function
AD26	P30.14	I	MP / PU1 / VFLEXE	General-purpose input
	TIN204			GTM input
	P30.14	O0		General-purpose output
	TOUT204	O1		GTM output
	—	O2		Reserved
	—	O3		Reserved
	—	O4		Reserved
	—	O5		Reserved
	—	O6		Reserved
	—	O7		Reserved
	AD1	HWOUT		EBU Address / Data Bus Line
	AE26	P30.15		I
TIN205		GTM input		
P30.15		O0	General-purpose output	
TOUT205		O1	GTM output	
—		O2	Reserved	
—		O3	Reserved	
—		O4	Reserved	
—		O5	Reserved	
—		O6	Reserved	
—		O7	Reserved	
AD6		HWOUT	EBU Address / Data Bus Line	

Table 2-44 Port 31 Functions

Pin	Symbol	Ctrl	Type	Function
AD18	P31.0	I	MP / PU1 / VFLEXE	General-purpose input
	TIN174			GTM input
	P31.0	O0		General-purpose output
	TOUT174	O1		GTM output
	—	O2		Reserved
	—	O3		Reserved
	—	O4		Reserved
	—	O5		Reserved
	—	O6		Reserved
	—	O7		Reserved
	AD30	HWOUT		EBU Address / Data Bus Line

Package and Pinning Definitions TC298x Pin Definition and Functions:

Table 2-44 Port 31 Functions (cont'd)

Pin	Symbol	Ctrl	Type	Function
AE18	P31.1	I	MP / PU1 / VFLEXE	General-purpose input
	TIN175			GTM input
	P31.1	O0		General-purpose output
	TOUT175	O1		GTM output
	—	O2		Reserved
	—	O3		Reserved
	—	O4		Reserved
	—	O5		Reserved
	—	O6		Reserved
	—	O7		Reserved
	AD29	HWOUT		EBU Address / Data Bus Line
AF18	P31.2	I	MP / PU1 / VFLEXE	General-purpose input
	TIN176			GTM input
	P31.2	O0		General-purpose output
	TOUT176	O1		GTM output
	—	O2		Reserved
	—	O3		Reserved
	—	O4		Reserved
	—	O5		Reserved
	—	O6		Reserved
	—	O7		Reserved
	AD28	HWOUT		EBU Address / Data Bus Line
AD19	P31.3	I	MP / PU1 / VFLEXE	General-purpose input
	TIN177			GTM input
	P31.3	O0		General-purpose output
	TOUT177	O1		GTM output
	—	O2		Reserved
	—	O3		Reserved
	—	O4		Reserved
	—	O5		Reserved
	—	O6		Reserved
	—	O7		Reserved
	AD26	HWOUT		EBU Address / Data Bus Line

Package and Pinning Definitions TC298x Pin Definition and Functions:
Table 2-44 Port 31 Functions (cont'd)

Pin	Symbol	Ctrl	Type	Function
AE19	P31.4	I	MP / PU1 / VFLEXE	General-purpose input
	TIN178			GTM input
	P31.4	O0		General-purpose output
	TOUT178	O1		GTM output
	—	O2		Reserved
	—	O3		Reserved
	—	O4		Reserved
	—	O5		Reserved
	—	O6		Reserved
	—	O7		Reserved
	AD24	HWOUT		EBU Address / Data Bus Line
AF19	P31.5	I	MP / PU1 / VFLEXE	General-purpose input
	TIN179			GTM input
	P31.5	O0		General-purpose output
	TOUT179	O1		GTM output
	—	O2		Reserved
	—	O3		Reserved
	—	O4		Reserved
	—	O5		Reserved
	—	O6		Reserved
	—	O7		Reserved
	AD23	HWOUT		EBU Address / Data Bus Line
AD20	P31.6	I	MP / PU1 / VFLEXE	General-purpose input
	TIN180			GTM input
	P31.6	O0		General-purpose output
	TOUT180	O1		GTM output
	—	O2		Reserved
	—	O3		Reserved
	—	O4		Reserved
	—	O5		Reserved
	—	O6		Reserved
	—	O7		Reserved
	AD20	HWOUT		EBU Address / Data Bus Line

Package and Pinning Definitions TC298x Pin Definition and Functions:
Table 2-44 Port 31 Functions (cont'd)

Pin	Symbol	Ctrl	Type	Function
AE20	P31.7	I	MP / PU1 / VFLEXE	General-purpose input
	TIN181			GTM input
	P31.7	O0		General-purpose output
	TOUT181	O1		GTM output
	—	O2		Reserved
	—	O3		Reserved
	—	O4		Reserved
	—	O5		Reserved
	—	O6		Reserved
	—	O7		Reserved
	AD16	HWOUT		EBU Address / Data Bus Line
AF20	P31.8	I	MP / PU1 / VFLEXE	General-purpose input
	TIN182			GTM input
	P31.8	O0		General-purpose output
	TOUT182	O1		GTM output
	—	O2		Reserved
	—	O3		Reserved
	—	O4		Reserved
	—	O5		Reserved
	—	O6		Reserved
	—	O7		Reserved
	AD31	HWOUT		EBU Address / Data Bus Line
AD21	P31.9	I	MP / PU1 / VFLEXE	General-purpose input
	TIN183			GTM input
	P31.9	O0		General-purpose output
	TOUT183	O1		GTM output
	—	O2		Reserved
	—	O3		Reserved
	—	O4		Reserved
	—	O5		Reserved
	—	O6		Reserved
	—	O7		Reserved
	AD27	HWOUT		EBU Address / Data Bus Line

Package and Pinning Definitions TC298x Pin Definition and Functions:

Table 2-44 Port 31 Functions (cont'd)

Pin	Symbol	Ctrl	Type	Function
AE21	P31.10	I	MP / PU1 / VFLEXE	General-purpose input
	TIN184			GTM input
	P31.10	O0		General-purpose output
	TOUT184	O1		GTM output
	—	O2		Reserved
	—	O3		Reserved
	—	O4		Reserved
	—	O5		Reserved
	—	O6		Reserved
	—	O7		Reserved
	AD21	HWOUT		EBU Address / Data Bus Line
AF21	P31.11	I	MP / PU1 / VFLEXE	General-purpose input
	TIN185			GTM input
	P31.11	O0		General-purpose output
	TOUT185	O1		GTM output
	—	O2		Reserved
	—	O3		Reserved
	—	O4		Reserved
	—	O5		Reserved
	—	O6		Reserved
	—	O7		Reserved
	AD25	HWOUT		EBU Address / Data Bus Line
AD22	P31.12	I	MP / PU1 / VFLEXE	General-purpose input
	TIN186			GTM input
	P31.12	O0		General-purpose output
	TOUT186	O1		GTM output
	—	O2		Reserved
	—	O3		Reserved
	—	O4		Reserved
	—	O5		Reserved
	—	O6		Reserved
	—	O7		Reserved
	AD19	HWOUT		EBU Address / Data Bus Line

Package and Pinning Definitions TC298x Pin Definition and Functions:

Table 2-44 Port 31 Functions (cont'd)

Pin	Symbol	Ctrl	Type	Function
AE22	P31.13	I	MP / PU1 / VFLEXE	General-purpose input
	TIN187			GTM input
	P31.13	O0		General-purpose output
	TOUT187	O1		GTM output
	—	O2		Reserved
	—	O3		Reserved
	—	O4		Reserved
	—	O5		Reserved
	—	O6		Reserved
	—	O7		Reserved
	AD22	HWOUT		EBU Address / Data Bus Line
AD23	P31.14	I	MP / PU1 / VFLEXE	General-purpose input
	TIN188			GTM input
	P31.14	O0		General-purpose output
	TOUT188	O1		GTM output
	—	O2		Reserved
	—	O3		Reserved
	—	O4		Reserved
	—	O5		Reserved
	—	O6		Reserved
	—	O7		Reserved
	AD18	HWOUT		EBU Address / Data Bus Line
AE23	P31.15	I	MP / PU1 / VFLEXE	General-purpose input
	TIN189			GTM input
	P31.15	O0		General-purpose output
	TOUT189	O1		GTM output
	—	O2		Reserved
	—	O3		Reserved
	—	O4		Reserved
	—	O5		Reserved
	—	O6		Reserved
	—	O7		Reserved
	AD17	HWOUT		EBU Address / Data Bus Line

Package and Pinning Definitions TC298x Pin Definition and Functions:
Table 2-45 Port 32 Functions

Pin	Symbol	Ctrl	Type	Function
AD17	P32.0	I	LP / PX/ VEXT	General-purpose input
	TIN36			GTM input
	FDEST			PMU input
	VGATE1N			SMPS mode: analog output. External Pass Device gate control for EVR13
	P32.0	O0		General-purpose output
	TOUT36	O1		GTM output
	–	O2		Reserved
	–	O3		Reserved
	–	O4		Reserved
	–	O5		Reserved
	–	O6		Reserved
	–	O7		Reserved
AE13	P32.2	I	LP / PU1 / VEXT	General-purpose input
	TIN38			GTM input
	ARX3D			ASCLIN3 input
	RXDCAN3B			CAN node 3 input
	RXDCANr1D			CAN node 1 input (MultiCANr+)
	P32.2	O0		General-purpose output
	TOUT38	O1		GTM output
	ATX3	O2		ASCLIN3 output
	–	O3		Reserved
	–	O4		Reserved
	–	O5		Reserved
	DCDCSYNC	O6		SCU output
–	O7	Reserved		
AF13	P32.3	I	LP / PU1 / VEXT	General-purpose input
	TIN39			GTM input
	P32.3	O0		General-purpose output
	TOUT39	O1		GTM output
	ATX3	O2		ASCLIN3 output
	–	O3		Reserved
	ASCLK3	O4		ASCLIN3 output
	TXDCAN3	O5		CAN node 3 output
	TXDCANr1	O6		CAN node 1 output (MultiCANr+)
	–	O7		Reserved

Package and Pinning Definitions TC298x Pin Definition and Functions:

Table 2-45 Port 32 Functions (cont'd)

Pin	Symbol	Ctrl	Type	Function
AC14	P32.4	I	MP+ / PU1 / VEXT	General-purpose input
	TIN40			GTM input
	ACTS1B			ASCLIN1 input
	SDI12			MSC1 input
	P32.4	O0		General-purpose output
	TOUT40	O1		GTM output
	–	O2		Reserved
	END12	O3		MSC1 output
	GTMCLK1	O4		GTM output
	EN10	O5		MSC1 output
	EXTCLK1	O6		SCU output
	COU63	O7		CCU60 output
AD14	P32.5	I	LP / PU1 / VEXT	General-purpose input
	TIN140			GTM input
	P32.5	O0		General-purpose output
	TOUT140	O1		GTM output
	ATX2	O2		ASCLIN2 output
	–	O3		Reserved
	–	O4		Reserved
	–	O5		Reserved
	TXDCAN2	O6		CAN node 2 output
	–	O7		Reserved
AE17	P32.6	I	LP / PU1 / VEXT	General-purpose input
	TGI4			OCDS input
	TIN141			GTM input
	RXDCAN2C			CAN node 2 input
	ARX2F			ASCLIN2 input
	P32.6	O0		General-purpose output
	TOUT141	O1		GTM output
	–	O2		Reserved
	–	O3		Reserved
	SLSO212	O4		QSPI2 output
	–	O5		Reserved
	–	O6		Reserved
	–	O7		Reserved
	TGO4	HWOUT		OCDS; ENx

Package and Pinning Definitions TC298x Pin Definition and Functions:

Table 2-45 Port 32 Functions (cont'd)

Pin	Symbol	Ctrl	Type	Function
AF17	P32.7	I	LP / PU1 / VEXT	General-purpose input
	TIN142			GTM input
	TGI5			OCDS input
	P32.7	O0		General-purpose output
	TOUT142	O1		GTM output
	—	O2		Reserved
	—	O3		Reserved
	—	O4		Reserved
	—	O5		Reserved
	—	O6		Reserved
	—	O7		Reserved
	TGO5	HWOUT		OCDS; ENx

Table 2-46 Port 33 Functions

Pin	Symbol	Ctrl	Type	Function
AC11	P33.0	I	LP / PU1 / VEXT	General-purpose input
	TIN22			GTM input
	DSITR0E			DSADC channel 0 input E
	P33.0	O0		General-purpose output
	TOUT22	O1		GTM output
	—	O2		Reserved
	—	O3		Reserved
	—	O4		Reserved
	—	O5		Reserved
	VADCG2BFL0	O6		VADC output
	—	O7		Reserved

Package and Pinning Definitions TC298x Pin Definition and Functions:

Table 2-46 Port 33 Functions (cont'd)

Pin	Symbol	Ctrl	Type	Function
AD11	P33.1	I	LP / PU1 / VEXT	General-purpose input
	TIN23			GTM input
	PSIRX0C			PSI5 input
	SENT9C			SENT input
	DSCIN2B			DSADC channel 2 input B
	DSITR1E			DSADC channel 1 input E
	P33.1			O0
	TOUT23	O1		GTM output
	ASLSO3	O2		ASCLIN3 output
	SCLK2	O3		QSPI2 output
	DSCOUT2	O4		DSADC channel 2 output
	VADCEMUX02	O5		VADC output
	VADCG2BFL1	O6		VADC output
	–	O7		Reserved
AE11	P33.2	I	LP / PU1 / VEXT	General-purpose input
	TIN24			GTM input
	SENT8C			SENT input
	DSDIN2B			DSADC channel 2 input B
	DSITR2E			DSADC channel 2 input E
	P33.2	O0		General-purpose output
	TOUT24	O1		GTM output
	ASCLK3	O2		ASCLIN3 output
	SLSO210	O3		QSPI2 output
	PSITX0	O4		PSI5 output
	VADCEMUX01	O5		VADC output
	VADCG2BFL2	O6		VADC output
	–	O7		Reserved

Package and Pinning Definitions TC298x Pin Definition and Functions:

Table 2-46 Port 33 Functions (cont'd)

Pin	Symbol	Ctrl	Type	Function
AF11	P33.3	I	LP / PU1 / VEXT	General-purpose input
	TIN25			GTM input
	PSIRX1C			PSI5 input
	SENT7C			SENT input
	DSCIN1B			DSADC channel 1 input B
	P33.3			O0
	TOUT25	O1		GTM output
	–	O2		Reserved
	–	O3		Reserved
	DSCOUT1	O4		DSADC channel 1 output
	VADCEMUX00	O5		VADC output
	VADCG2BFL3	O6		VADC output
	–	O7		Reserved
	AC12	P33.4		I
TIN26		GTM input		
SENT6C		SENT input		
CTR \overline APC		CCU61 input		
DSDIN1B		DSADC channel 1 input		
DSITR0F		DSADC channel 0 input F		
P33.4		O0	General-purpose output	
TOUT26		O1	GTM output	
ARTS2		O2	ASCLIN2 output	
SLSO212		O3	QSPI2 output	
PSITX1		O4	PSI5 output	
VADCEMUX12		O5	VADC output	
VADCG0BFL0		O6	VADC output	
–		O7	Reserved	

Package and Pinning Definitions TC298x Pin Definition and Functions:

Table 2-46 Port 33 Functions (cont'd)

Pin	Symbol	Ctrl	Type	Function
AD12	P33.5	I	LP / PU1 / VEXT	General-purpose input
	TIN27			GTM input
	ACTS2B			ASCLIN2 input
	PSIRX2C			PSI5 input
	PSISRXC			PSI5-S input
	SENT5C			SENT input
	CCPOS2C			CCU61 input
	T4EADB			GPT120 input
	DSCIN0B			DSADC channel 0 input B
	DSITR1F			DSADC channel 1 input F
	P33.5			O0
	TOUT27	O1	GTM output	
	SLSO07	O2	QSPI0 output	
	SLSO17	O3	QSPI1 output	
	DSCOUT0	O4	DSADC channel 0 output	
	VADCEMUX11	O5	VADC output	
	VADCG0BFL1	O6	VADC output	
	-	O7	Reserved	
AE12	P33.6	I	LP / PU1 / VEXT	General-purpose input
	TIN28			GTM input
	SENT4C			SENT input
	CCPOS1C			CCU61 input
	T2EADB			GPT120 input
	DSDIN0B			DSADC channel 0 input B
	DSITR2F			DSADC channel 2 input F
	P33.6	O0	General-purpose output	
	TOUT28	O1	GTM output	
	ASLSO2	O2	ASCLIN2 output	
	SLSO211	O3	QSPI2 output	
	PSITX2	O4	PSI5 output	
	VADCEMUX10	O5	VADC output	
	VADCG1BFL0	O6	VADC output	
	PSISTX	O7	PSI5-S output	

Package and Pinning Definitions TC298x Pin Definition and Functions:

Table 2-46 Port 33 Functions (cont'd)

Pin	Symbol	Ctrl	Type	Function
AC15	P33.7	I	LP / PU1 / VEXT	General-purpose input
	TIN29			GTM input
	RXDCAN0E			CAN node 0 input
	REQ8			SCU input
	CCPOS0C			CCU61 input
	T2INB			GPT120 input
	P33.7			O0
	TOUT29	O1		GTM output
	ASCLK2	O2		ASCLIN2 output
	SLSO47	O3		QSPI4 output
	–	O4		Reserved
	–	O5		Reserved
	VADCG1BFL1	O6		VADC output
	–	O7		Reserved
AD15	P33.8	I	MP / HighZ / VEXT	General-purpose input
	TIN30			GTM input
	ARX2E			ASCLIN2 input
	EMGSTOPA			SCU input
	P33.8	O0		General-purpose output
	TOUT30	O1		GTM output
	ATX2	O2		ASCLIN2 output
	SLSO42	O3		QSPI4 output
	–	O4		Reserved
	TXDCAN0	O5		CAN node 0 output
	–	O6		Reserved
	COUT62	O7		CCU61 output
	SMUFSP	HWOUT		SMU
	AF12	P33.9		I
TIN31		GTM input		
HSIC3INA		QSPI3 input		
P33.9		O0	General-purpose output	
TOUT31		O1	GTM output	
ATX2		O2	ASCLIN2 output	
SLSO41		O3	QSPI4 output	
ASCLK2		O4	ASCLIN2 output	
–		O5	Reserved	
–		O6	Reserved	
CC62		O7	CCU61 output	

Package and Pinning Definitions TC298x Pin Definition and Functions:

Table 2-46 Port 33 Functions (cont'd)

Pin	Symbol	Ctrl	Type	Function
AE14	P33.10	I	MP / PU1 / VEXT	General-purpose input
	TIN32			GTM input
	SLSI4A			QSPI4 input
	HSIC3INB			QSPI3 input
	P33.10	O0		General-purpose output
	TOUT32	O1		GTM output
	SLSO16	O2		QSPI1 output
	SLSO40	O3		QSPI4 output
	ASLSO1	O4		ASCLIN1 output
	PSISCLK	O5		PSI5-S output
	–	O6		Reserved
COUT61	O7	CCU61 output		
AF14	P33.11	I	MP / PU1 / VEXT	General-purpose input
	TIN33			GTM input
	SCLK4A			QSPI4 input
	P33.11			O0
	TOUT33	O1		GTM output
	ASCLK1	O2		ASCLIN1 output
	SCLK4	O3		QSPI4 output
	–	O4		Reserved
	–	O5		Reserved
	DSCGPWMN	O6		DSADC channel output
	CC61	O7		CCU61 output
AF15	P33.12	I	MP / PU1 / VEXT	General-purpose input
	TIN34			GTM input
	MTSR4A			QSPI4 input
	P33.12			O0
	TOUT34	O1		GTM output
	ATX1	O2		ASCLIN1 output
	MTSR4	O3		QSPI4 output
	ASCLK1	O4		ASCLIN1 output
	–	O5		Reserved
	DSCGPWMP	O6		DSADC output
	COUT60	O7		CCU61 output

Package and Pinning Definitions TC298x Pin Definition and Functions:

Table 2-46 Port 33 Functions (cont'd)

Pin	Symbol	Ctrl	Type	Function
AE15	P33.13	I	MP / PU1 / VEXT	General-purpose input
	TIN35			GTM input
	ARX1F			ASCLIN1 input
	MRST4A			QSPI4 input
	DSSGNB			DSADC channel input B
	INJ11			MSC1 input
	P33.13			O0
	TOUT35	O1		GTM output
	ATX1	O2		ASCLIN1 output
	MRST4	O3		QSPI4 output
	SLSO26	O4		QSPI2 output
	–	O5		Reserved
	DCDCSYNC	O6		SCU output
	CC60	O7		CCU61 output
AC13	P33.14	I	LP / PU1 / VEXT	General-purpose input
	TIN143			GTM input
	$\overline{\text{TGI6}}$			OCDS input
	SCLK2D			QSPI2 input
	P33.14	O0		General-purpose output
	TOUT143	O1		GTM output
	–	O2		Reserved
	SCLK2	O3		QSPI2 output
	–	O4		Reserved
	–	O5		Reserved
	–	O6		Reserved
	CC62	O7		CCU60 output
	$\overline{\text{TGO6}}$	HWOUT		OCDS; ENx

Package and Pinning Definitions TC298x Pin Definition and Functions:

Table 2-46 Port 33 Functions (cont'd)

Pin	Symbol	Ctrl	Type	Function
AD13	P33.15	I	LP / PU1 / VEXT	General-purpose input
	TIN144			GTM input
	TGI7			OCDS input
	P33.15	O0		General-purpose output
	TOUT144	O1		GTM output
	—	O2		Reserved
	SLSO211	O3		QSPI2 output
	—	O4		Reserved
	—	O5		Reserved
	—	O6		Reserved
	COU62	O7		CCU60 output
	TGO7	HWOUT		OCDS; ENx

Table 2-47 Port 34 Functions

Pin	Symbol	Ctrl	Type	Function
AC9	P34.1	I	LP / PU1 / VEXT	General-purpose input
	TIN146			GTM input
	P34.1	O0		General-purpose output
	TOUT146	O1		GTM output
	ATX0	O2		ASCLIN0 output
	—	O3		Reserved
	TXDCAN0	O4		CAN node 0 output
	TXDCANr0	O5		CAN node 0 output (MultiCANr+)
	—	O6		Reserved
	COU63	O7		CCU60 output
AC10	P34.2	I	LP / PU1 / VEXT	General-purpose input
	TIN147			GTM input
	ARX0D			ASCLIN0 input
	RXDCAN0G			CAN node 0 input
	RXDCANr0C			CAN node 0 input (MultiCANr+)
	P34.2	O0		General-purpose output
	TOUT147	O1		GTM output
	—	O2		Reserved
	—	O3		Reserved
	—	O4		Reserved
	—	O5		Reserved
	—	O6		Reserved
	CC60	O7		CCU60 output

Package and Pinning Definitions TC298x Pin Definition and Functions:

Table 2-47 Port 34 Functions (cont'd)

Pin	Symbol	Ctrl	Type	Function
AF10	P34.3	I	LP / PU1 / VEXT	General-purpose input
	TIN148			GTM input
	P34.3			General-purpose output
	TOUT148	O0		GTM output
	—	O1		Reserved
	—	O2		Reserved
	—	O3		Reserved
	SLSO210	O4		QSPI2 output
	—	O5		Reserved
	—	O6		Reserved
COUT60	O7	CCU60 output		
AD10	P34.4	I	LP / PU1 / VEXT	General-purpose input
	TIN149			GTM input
	MRST2D			QSPI2 input
	P34.4	O0		General-purpose output
	TOUT149	O1		GTM output
	—	O2		Reserved
	—	O3		Reserved
	MRST2	O4		QSPI2 output
	—	O5		Reserved
	—	O6		Reserved
CC61	O7	CCU60 output		
AE10	P34.5	I	LP / PU1 / VEXT	General-purpose input
	TIN150			GTM input
	MTRSR2D			QSPI2 input
	P34.5	O0		General-purpose output
	TOUT150	O1		GTM output
	—	O2		Reserved
	—	O3		Reserved
	MTRSR2	O4		QSPI2 output
	—	O5		Reserved
	—	O6		Reserved
COUT61	O7	CCU60 output		

Package and Pinning Definitions TC298x Pin Definition and Functions:
Table 2-48 Port 40 Functions

Pin	Symbol	Ctrl	Type	Function
AC7	P40.0	I	S / HighZ / VDDM	General-purpose input
	VADCG3.0			VADC analog input channel 0 of group 3
	DS2PB			DSADC: positive analog input of channel 2, pin B
	CCPOS0D			CCU60 input
	SENT0A			SENT input
AD7	P40.1	I	S / HighZ / VDDM	General-purpose input
	VADCG3.1			VADC analog input channel 1 of group 3 (with pull down diagnostics)
	DS2NB			DSADC: negative analog input channel 2, pin B
	CCPOS1B			CCU60 input
	SENT1A			SENT input
AA2	P40.2	I	S / HighZ / VDDM	General-purpose input
	VADCG3.2			VADC analog input channel 2 of group 3 (with pull down diagnostics)
	CCPOS1D			CCU60 input
	SENT2A			SENT input
AB2	P40.3	I	S / HighZ / VDDM	General-purpose input
	VADCG3.3			VADC analog input channel 3 of group 3 (with pull down diagnostics)
	CCPOS2B			CCU60 input
	SENT3A			SENT input
W3	P40.4	I	S / HighZ / VDDM	General-purpose input
	VADCG4.0			VADC analog input channel 0 of group 4
	CCPOS2D			CCU60 input
	SENT4A			SENT input
Y3	P40.5	I	S / HighZ / VDDM	General-purpose input
	VADCG4.1			VADC analog input channel 1 of group 4
	CCPOS0D			CCU61 input
	SENT5A			SENT input
V4	P40.6	I	S / HighZ / VDDM	General-purpose input
	VADCG4.4			VADC analog input channel 4 of group 4
	DS3PA			DSADC: positive analog input of channel 3, pin A
	CCPOS1B			CCU61 input
	SENT6A			SENT input

Package and Pinning Definitions TC298x Pin Definition and Functions:
Table 2-48 Port 40 Functions (cont'd)

Pin	Symbol	Ctrl	Type	Function
V3	P40.7	I	S / HighZ / VDDM	General-purpose input
	VADCG4.5			VADC analog input channel 5 of group 4
	DS3NA			DSADC: negative analog input channel 3, pin A
	CCPOS1D			CCU61 input
	SENT7A			SENT input
V2	P40.11	I	S / HighZ / VDDM	General-purpose input
	VADCG10.4			VADC analog input channel 4 of group 10
	DS8PA			DSADC: positive analog input of channel 8, pin A
	SENT11A			SENT input
W1	P40.12	I	S / HighZ / VDDM	General-purpose input
	VADCG10.5			VADC analog input channel 5 of group 10
	DS8NA			DSADC: positive analog input of channel 8, pin A
	SENT12A			SENT input
U2	P40.13	I	S / HighZ / VDDM	General-purpose input
	VADCG10.6			VADC analog input channel 6 of group 10
	DS9PA			DSADC: positive analog input of channel 9, pin A
	SENT13A			SENT input
V1	P40.14	I	S / HighZ / VDDM	General-purpose input
	VADCG10.7			VADC analog input channel 7 of group 10
	DS9NA			DSADC: positive analog input of channel 9, pin A
	SENT14A			SENT input

Table 2-49 Analog Inputs

Pin	Symbol	Ctrl	Type	Function
AC5	AN0	I	D / HighZ / VDDM	Analog input 0
	VADCG0.0			VADC analog input channel 0 of group 0
	DS1PA			DSADC: positive analog input of channel 1, pin A
AD5	AN1	I	D / HighZ / VDDM	Analog input 1
	VADCG0.1			VADC analog input channel 1 of group 0
	DS1NA			DSADC: negative analog input channel 1, pin A
AE4	AN2	I	D / HighZ / VDDM	Analog input 2
	VADCG0.2			VADC analog input channel 2 of group 0
	DS0PA			DSADC: positive analog input of channel 0, pin A
AF4	AN3	I	D / HighZ / VDDM	Analog input 3
	VADCG0.3			VADC analog input channel 3 of group 0
	DS0NA			DSADC: negative analog input channel 0, pin A
AC2	AN4	I	D / HighZ / VDDM	Analog input 4
	VADCG0.4			VADC analog input channel 4 of group 0

Package and Pinning Definitions TC298x Pin Definition and Functions:
Table 2-49 Analog Inputs (cont'd)

Pin	Symbol	Ctrl	Type	Function
AA3	AN5	I	D / HighZ / VDDM	Analog input 5
	VADCG0.5			VADC analog input channel 5 of group 0
AD1	AN6	I	D / HighZ / VDDM	Analog input 6
	VADCG0.6			VADC analog input channel 6 of group 0
AB4	AN7	I	D / HighZ / VDDM	Analog input 7
	VADCG0.7			VADC analog input channel 7 of group 0
AC4	AN8	I	D / HighZ / VDDM	Analog input 8
	VADCG1.0			VADC analog input channel 0 of group 1
AD4	AN9	I	D / HighZ / VDDM	Analog input 9
	VADCG1.1			VADC analog input channel 1 of group 1
AE3	AN10	I	D / HighZ / VDDM	Analog input 10
	VADCG1.2			VADC analog input channel 2 of group 1
AF3	AN11	I	D / HighZ / VDDM	Analog input 11
	VADCG1.3			VADC analog input channel 3 of group 1 (with pull down diagnostics)
AC3	AN16	I	D / HighZ / VDDM	Analog input 16
	VADCG2.0			VADC analog input channel 0 of group 2
AD3	AN17	I	D / HighZ / VDDM	Analog input 17
	VADCG2.1			VADC analog input channel 1 of group 2
AE2	AN18	I	D / HighZ / VDDM	Analog input 18
	VADCG2.2			VADC analog input channel 2 of group 2
AF2	AN19	I	D / HighZ / VDDM	Analog input 19
	VADCG2.3			VADC analog input channel 3 of group 2 (with pull down diagnostics)
AC8	AN20	I	D / HighZ / VDDM	Analog input 20
	VADCG2.4			VADC analog input channel 4 of group 2
	DS2PA			DSADC: positive analog input of channel 2, pin A
AD8	AN21	I	D / HighZ / VDDM	Analog input 21
	VADCG2.5			VADC analog input channel 5 of group 2
	DS2NA			DSADC: negative analog input channel 2, pin A
AE8	AN22	I	D / HighZ / VDDM	Analog input 22
	VADCG2.6			VADC analog input channel 6 of group 2
AF8	AN23	I	D / HighZ / VDDM	Analog input 23
	VADCG2.7			VADC analog input channel 7 of group 2
AC7	AN24	I	S / HighZ / VDDM	Analog input 24
	VADCG3.0			VADC analog input channel 0 of group 3
	DS2PB			DSADC: positive analog input of channel 2, pin B
	SENT0A			SENT input channel 0, pin A

Package and Pinning Definitions TC298x Pin Definition and Functions:
Table 2-49 Analog Inputs (cont'd)

Pin	Symbol	Ctrl	Type	Function
AD7	AN25	I	S / HighZ / VDDM	Analog input 24
	VADCG3.1			VADC analog input channel 1 of group 3 (with pull down diagnostics)
	DS2NB			DSADC: negative analog input channel 2, pin B
	SENT1A			SENT input channel 1, pin A
AA2	AN26	I	S / HighZ / VDDM	Analog input 26
	VADCG3.2			VADC analog input channel 2 of group 3 (with pull down diagnostics)
	SENT2A			SENT input channel 2, pin A
AB2	AN27	I	S / HighZ / VDDM	Analog input 27
	VADCG3.3			VADC analog input channel 3 of group 3 (with pull down diagnostics)
	SENT3A			SENT input channel 3, pin A
AB1	AN28	I	D / HighZ / VDDM	Analog input 28
	VADCG3.4			VADC analog input channel 4 of group 3 (with pull down diagnostics)
AC1	AN29	I	D / HighZ / VDDM	Analog input 29
	VADCG3.5			VADC analog input channel 5 of group 3 (with pull down diagnostics)
W3	AN32	I	S / HighZ / VDDM	Analog input 32
	VADCG4.0			VADC analog input channel 0 of group 4
	SENT4A			SENT input channel 4, pin A
Y3	AN33	I	S / HighZ / VDDM	Analog input 33
	VADCG4.1			VADC analog input channel 1 of group 4
	SENT5A			SENT input channel 5, pin A
V4	AN36	I	S / HighZ / VDDM	Analog input 34
	VADCG4.4			VADC analog input channel 4 of group 4
	DS3PA			DSADC: positive analog input of channel 3, pin A
	SENT6A			SENT input channel 6, pin A
V3	AN37	I	S / HighZ / VDDM	Analog input 37
	VADCG4.5			VADC analog input channel 5 of group 4
	DS3NA			DSADC: negative analog input channel 3, pin A
	SENT7A			SENT input channel 7, pin A
U4	AN40	I	D / HighZ / VDDM	Analog input 40
	VADCG5.0			VADC analog input channel 0 of group 5
U3	AN41	I	D / HighZ / VDDM	Analog input 41
	VADCG5.1			VADC analog input channel 1 of group 5
T1	AN42	I	D / HighZ / VDDM	Analog input 42
	VADCG5.2			VADC analog input channel 2 of group 5

Package and Pinning Definitions TC298x Pin Definition and Functions:
Table 2-49 Analog Inputs (cont'd)

Pin	Symbol	Ctrl	Type	Function
U1	AN43	I	D / HighZ / VDDM	Analog input 43
	VADCG5.3			VADC analog input channel 3 of group 5 (with pull down diagnostics)
AD2	AN48	I	D / HighZ / VDDM	Analog input 48
	VADCG8.0			VADC analog input channel 0 of group 8
AE1	AN49	I	D / HighZ / VDDM	Analog input 49
	VADCG8.1			VADC analog input channel 1 of group 8 (muxtest)
AE6	AN52	I	D / HighZ / VDDM	Analog input 52
	VADCG8.4			VADC analog input channel 4 of group 8
	DS6PA			DSADC: positive analog input of channel 6, pin A
AF6	AN53	I	D / HighZ / VDDM	Analog input 53
	VADCG8.5			VADC analog input channel 5 of group 8
	DS6NA			DSADC: negative analog input channel 6, pin A
AE7	AN54	I	D / HighZ / VDDM	Analog input 5
	VADCG8.6			VADC analog input channel 6 of group 8
	DS6PB			DSADC: positive analog input of channel 6, pin B
AF7	AN55	I	D / HighZ / VDDM	Analog input 50
	VADCG8.7			VADC analog input channel 7 of group 8
	DS6NB			DSADC: negative analog input channel 6, pin B
AA4	AN56	I	D / HighZ / VDDM	Analog input 56
	VADCG9.0			VADC analog input channel 0 of group 9
AB3	AN57	I	D / HighZ / VDDM	Analog input 57
	VADCG9.1			VADC analog input channel 1 of group 9 (muxtest)
Y2	AN60	I	D / HighZ / VDDM	Analog input 60
	VADCG9.4			VADC analog input channel 4 of group 9
	DS7PA			DSADC: positive analog input of channel 7, pin A
AA1	AN61	I	D / HighZ / VDDM	Analog input 61
	VADCG9.5			VADC analog input channel 5 of group 9
	DS7NA			DSADC: negative analog input channel 7, pin A
W2	AN64	I	D / HighZ / VDDM	Analog input 64
	VADCG10.0			VADC analog input channel 0 of group 10
Y1	AN65	I	D / HighZ / VDDM	Analog input 65
	VADCG10.1			VADC analog input channel 1 of group 10 (muxtest)
V2	AN68	I	S / HighZ / VDDM	Analog input 68
	VADCG10.4			VADC analog input channel 4 of group 10
	DS8PA			DSADC: positive analog input of channel 8, pin A
	SENT11A			SENT input channel 11, pin A

Package and Pinning Definitions TC298x Pin Definition and Functions:
Table 2-49 Analog Inputs (cont'd)

Pin	Symbol	Ctrl	Type	Function
W1	AN69	I	S / HighZ / VDDM	Analog input 69
	VADCG10.5			VADC analog input channel 5 of group 10
	DS8NA			DSADC: negative analog input channel 8, pin A
	SENT12A			SENT input channel 12, pin A
U2	AN70	I	S / HighZ / VDDM	Analog input 70
	VADCG10.6			VADC analog input channel 6 of group 10
	DS9PA			DSADC: positive analog input of channel 9, pin A
	SENT13A			SENT input channel 13, pin A
V1	AN71	I	S / HighZ / VDDM	Analog input 71
	VADCG10.7			VADC analog input channel 7 of group 10
	DS9NA			DSADC: negative analog input channel 9, pin A
	SENT14A			SENT input channel 14, pin A

Table 2-50 System I/O

Pin	Symbol	Ctrl	Type	Function
B22	$\overline{\text{PORST}}$	I	PORST / PD / VEXT	Power On Reset Input Additional strong PD in case of power fail.
A23	$\overline{\text{ESR0}}$	I/O	MP / OD / VEXT	External System Request Reset 0 Default configuration during and after reset is open-drain driver. The driver drives low during power-on reset. This is valid additionally after deactivation of PORST until the internal reset phase has finished. See also SCU chapter for details. Default after power-on can be different. See also SCU chapter 'Reset Control Unit' and SCU_IOCRR register description.
	EVRWUP	I		EVR Wakeup Pin
A22	$\overline{\text{ESR1}}$	I/O	MP / PU1 / VEXT	External System Request Reset 1 Default NMI function. See also SCU chapter 'Reset Control Unit' and SCU_IOCRR register description.
	EVRWUP	I		EVR Wakeup Pin
AC17	VGATE1P	O	VGATE1P / - / VEXT	External Pass Device gate control for EVR13
AC21	VGATE3P	O	VGATE3P / - / VEXT	External Pass Device gate control for EVR33
F24	TMS	I	A2 / PD / VDDP3	JTAG Module State Machine Control Input
	DAP1	I/O		Device Access Port Line 1

Package and Pinning Definitions TC298x Pin Definition and Functions:
Table 2-50 System I/O (cont'd)

Pin	Symbol	Ctrl	Type	Function
F23	$\overline{\text{TRST}}$	I	A2 / PD / VDDP3	JTAG Module Reset/Enable Input
E24	TCK	I	A2 / PD / VDDP3	JTAG Module Clock Input
	DAP0	I		Device Access Port Line 0
G26	XTAL1	I	XTAL1 / - / VDDP3	Main Oscillator/PLL/Clock Generator Input
G25	XTAL2	O	XTAL2 / - / VDDP3	Main Oscillator/PLL/Clock Generator Output

Table 2-51 Supply

Pin	Symbol	Ctrl	Type	Function
AD6	VAREF1	I	Vx	Positive Analog Reference Voltage 1
AC6	VAGND1	I	Vx	Negative Analog Reference Voltage 1
W4	VAREF2	I	Vx	Positive Analog Reference Voltage 2
Y4	VAGND2	I	Vx	Negative Analog Reference Voltage 2
AE9, AE5	VDDM	I	Vx	ADC Analog Power Supply (3.3V / 5V)
R1, R4	NC / VDDSB	I	NCVDD SB	Emulation Device: Emulation SRAM Standby Power Supply (1.3V) (Emulation Device only). Production Device: Not Connected.
P23, V23, AB23, AC20, B26, C25, D9, D24, E23, H4	VDD	I	Vx	Digital Core Power Supply (1.3V)
F26	VDD	I	Vx	Digital Core Power Supply (1.3V). The supply pin inturn supplies the main XTAL Oscillator/PLL (1.3V) . A higher decoupling capacitor is therefore recommended to the VSS pin for better noise immunity.
A25, B24, C23, D14, D22, K4, AC16, AD16, AE16, AF16	VEXT	I	Vx	External Power Supply (5V / 3.3V)
H24, H25, H26	VDDP3	I	Vx	Digital Power Supply for Flash (3.3V). Can be also used as external 3.3V Power Supply for VFLEX.

Package and Pinning Definitions TC298x Pin Definition and Functions:
Table 2-51 Supply (cont'd)

Pin	Symbol	Ctrl	Type	Function
E26	VDDP3	I	Vx	Digital Power Supply for Oscillator, LVDSH and A2 pads (3.3V). The supply pin inturn supplies the main XTAL Oscillator/PLL (3.3V) . A higher decoupling capacitor is therefore recommended to the VSS pin for better noise immunity.
A18, B18	VDDFL3	I	Vx	Flash Power Supply (3.3V)
D7	VFLEX	I	Vx	Digital Power Supply for Flex Port Pads (5V / 3.3V)
AC18, AC22	VFLEXE	I	Vx	Digital Power Supply for EBU Flex Port Pads (5V / 3.3V)
M23, T23, Y23	VEBU	I	Vx	Digital Power Supply for EBU (3.3V)
AF5, AF9	VSSM	I	Vx	Analog Ground for VDDM
AD9	VEVRSB	I	Vx	Standby Power Supply (3.3V/5V) for the Standby SRAM (CPU0.DSPR). If Standby mode is not used: To be handled like VEXT (3.3V/5V).
A26, B25, C24, D8, D15, D23, F25, J4, L23, R23, T4, W23, AC19, AC23	VSS	I	Vx	Digital Ground (outer balls)
K10, K11, K12, K13, K14, K15, K16, K17, L10, L11, L12, L13, L14, L15, L16, L17	VSS	I	Vx	Digital Ground (center balls)
M10, M11, M12, M13, M14, M15, M16, M17, N10, N11, N12, N13, N14, N15, N16, N17	VSS	I	Vx	Digital Ground (center balls)
P11, P12, P13, P14, P15, P16, R11, R12, R13, R14, R15, R16	VSS	I	Vx	Digital Ground (center balls)
T10, T11, T12, T13, T14, T15, T16, T17, U10, U11, U14, U15, U16, U17	VSS	I	Vx	Digital Ground (center balls)
U12	VSS	I	Vx	Digital Ground (center balls) This ball is used in the Emulation Device as AGBT TX0N

Package and Pinning Definitions TC298x Pin Definition and Functions:
Table 2-51 Supply (cont'd)

Pin	Symbol	Ctrl	Type	Function
U13	VSS	I	Vx	Digital Ground (center balls) This ball is used in the Emulation Device as AGBT TX0P
R10	VSS	I	Vx	Digital Ground (center balls) This ball is used in the Emulation Device as AGBT CLKN
P10	VSS	I	Vx	Digital Ground (center balls) This ball is used in the Emulation Device as AGBT CLKP
R17	VSS	I	Vx	Digital Ground (center balls) This ball is used in the Emulation Device as AGBT ERR
P17	NC / VDDPSB	I	NCVDD PSB	Emulation Device: Power Supply (3.3V) for DAP/JTAG pad group. Can be connected to VDDP or can be left unsupplied (see document 'AurixED' / Aurix Emulation Devices specification). Production Device: This pin is not connected on package level. It can be connected on PCB level to VDDP or Ground or can be left unsupplied.
A1, AF1, AF26	NC	I	NC1	Not Connected. These pins are not connected on package level and will not be used for future extensions.

Legend:

 Column "**Ctrl.**":

 I = Input (for GPIO port Lines with IOCR bit field Selection PCx = 0XXX_B)

O = Output

 O0 = Output with IOCR bit field selection PCx = 1X000_B

 O1 = Output with IOCR bit field selection PCx = 1X001_B (ALT1)

 O2 = Output with IOCR bit field selection PCx = 1X010_B (ALT2)

 O3 = Output with IOCR bit field selection PCx = 1X011_B (ALT3)

 O4 = Output with IOCR bit field selection PCx = 1X100_B (ALT4)

 O5 = Output with IOCR bit field selection PCx = 1X101_B (ALT5)

 O6 = Output with IOCR bit field selection PCx = 1X110_B (ALT6)

 O7 = Output with IOCR bit field selection PCx = 1X111_B (ALT7)

 Column "**Type**":

Package and Pinning Definitions TC298x Pin Definition and Functions:

LP = Pad class LP (5V/3.3V, Class LP parameters for digital input / output and class D parameters for analog input function)

MP = Pad class MP (5V/3.3V)

MP+ = Pad class MP+ (5V/3.3V)

MPR = Pad class MPR (5V/3.3V)

A2 = Pad class A2 (3.3V)

LVDSM = Pad class LVDSM (5V/3.3V)

LVDSH = Pad class LVDSH (3.3V)

S = Pad class S (Class S parameters for digital input and class D parameters for analog input function)

D = Pad class D (VADC / DSADC)

PU = with pull-up device connected during reset ($\overline{\text{PORST}} = 0$)

PU1 = with pull-up device connected during reset ($\overline{\text{PORST}} = 0$)^{1) 2) 3)}

PD = with pull-down device connected during reset ($\overline{\text{PORST}} = 0$)

PD1 = with pull-down device connected during reset ($\overline{\text{PORST}} = 0$)^{1) 2) 3)}

PX = Behavior depends on usage: PD in EVR13 SMPS Mode and PU1 in GPIO Mode

OD = open drain during reset ($\overline{\text{PORST}} = 0$)

HighZ = tri-state during reset ($\overline{\text{PORST}} = 0$)

PORST = PORST input pad

XTAL1 = XTAL1 input pad

XTAL2 = XTAL2 input pad

VGATE1P = VGATE1P

VGATE3P = VGATE3P

Vx = Supply

NC = These pins are reserved for future extensions and shall not be connected externally

NC1 = These pins are not connected on package level and will not be used for future extensions

NCVDDPSB = This pin has a different functionality in an Production Device and an Emulation Device. For details pls. see Pin/Ball description of this pin.

NCVDDSB = This pin has a different functionality in an Production Device and an Emulation Device. For details pls. see Pin/Ball description of this pin.

2.2.2 Emergency Stop Function

The Emergency Stop function can be used to force GPIOs (General Purpose Inputs/Outputs) via an external input signal (EMGSTOPA or EMGSTOPB) into a defined state:

- Input state and
- PU or High-Z depending on HWCFG[6] level latched during Porst active

Control of the Emergency Stop function:

- The Emergency Stop function can be enabled/disabled in the SCU (see chapter "SCU", "Emergency Stop Control")
- The Emergency Stop input signal, EMGSTOPA (P33.8) / EMGSTOPB (P21.2), can selected in the SCU (see chapter "SCU", "Emergency Stop Control")

1) The default state of GPIOs (Px.y) during and after PORST active is controlled via HWCFG[6] (P14.4). HWCFG[6] has a weak internal pull-up active at start-up if the pin is left unconnected. See also User's Manual, "Introduction Chapter", "General Purpose I/O Ports and Peripheral I/O Lines", Figure: "Default state of port pins during and after reset".

2) If HWCFG[6] is left unconnected or is externally pulled high, weak internal pull-ups (PU1) / pull-downs (PD1) are active during and after reset.

3) If HWCFG[6] is connected to ground, the PD1 / PU1 pins are predominantly in HighZ during and after reset.

Package and Pinning Definitions TC298x Pin Definition and Functions:

- On port level, each GPIO can be enabled/disabled for the Emergency Stop function via the Px_ESR (Port x Emergency Stop) registers in the port control logic (see chapter “General Purpose I/O Ports and Peripheral I/O Lines”, “Emergency Stop Register”).

The Emergency Stop function is available for all GPIO Ports with the following exceptions:

- Not available for P20.2 (General Purpose Input/GPI only, overlaid with Testmode)
- Not available for P40.x (analog input ANx overlaid with GPI)
- Not available for P32.0 EVR13 SMPS mode.
- Not available for dedicated I/O without General Purpose Output function (e.g ESRx, TMS, TCK)

The Emergency Stop function can be overruled on the following GPIO Ports:

- P00.x and P02.x: Emergency Stop can be overruled by the 8-Bit Standby Controller (SBR), if implemented. Overruling can be disabled via the control registers P00_SCR / P02_SCR (see chapter “General Purpose I/O Ports and Peripheral I/O Lines”, P00 / P01)
- P00.x: Emergency Stop can be overruled by the VADC. Overruling can be disabled via the control register P00_SCR (see chapter “General Purpose I/O Ports and Peripheral I/O Lines”, P00)
- P14.0 and P14.1: Emergency Stop can be overruled in the DXCPL mode (DAP over can physical layer mode). No Overruling in the DXCM (Debug over can message) mode
- P21.6: Emergency Stop can be overruled in JTAG mode if this pin is used as TDI
- P21.7: Emergency Stop can be overruled in JTAG or Three Pin DAP mode
- P20.0: Emergency Stop can be overruled in JTAG mode if this GPIO is used as TDI
- P33.8: Emergency Stop can be overruled if this pin is used as safety output pin (SMUFSP)

2.2.3 Pull-Up/Pull-Down Reset Behavior of the Pins

Table 2-52 List of Pull-Up/Pull-Down Reset Behavior of the Pins

Pins	PORST = 0	PORST = 1
all GPIOs	Pull-up if HWCFG[6] = 1 or High-Z if HWCFG[6] = 0	
TDI, TESTMODE	Pull-up	
PORST ¹⁾	Pull-down with I_{PORST} relevant	Pull-down with I_{PDLI} relevant
TRST, TCK, TMS	Pull-down	
ESR0	The open-drain driver is used to drive low. ²⁾	Pull-up ³⁾
ESR1	Pull-up ³⁾	
TDO	Pull-up	High-Z/Pull-up ⁴⁾

1) Pull-down with I_{PORST} relevant is always activated when a primary supply monitor detects a violation.

2) Valid additionally after deactivation of PORST until the internal reset phase has finished. See the SCU chapter for details.

3) See the SCU_IOCRR register description.

4) Depends on JTAG/DAP selection with TRST.

In case of leakage test ($\overline{PORST} = 0$ and $\overline{TESTMODE} = 0$), the pull-down of the \overline{TRST} pin is switched off. In case of an user application ($\overline{TESTMODE} = 1$), the pull-down of the \overline{TRST} is always switched on.

Package and Pinning Definitions TC297x Pin Definition and Functions:

2.3 TC297x Pin Definition and Functions: BGA292

Figure 2-3 is showing the TC297x Logic Symbol for the package variant: BGA292.

	20	19	18	17	16	15	14	13	12	11	10	9	8	7	6	5	4	3	2	1			
Y	VSS	P32.3	P32.2	P32.0	P33.13	P33.11	P33.9	P33.7	P33.5	P33.3	P33.1	AN5	AN10	VAGND1	VAREF1	VDDM	VSSM	AN20	AN21	NC	Y		
W	VEXT	VSS	P32.4	VGATE1P	P33.12	P33.10	P33.8	P33.6	P33.4	P33.2	P33.0	AN2	AN8	AN11	AN13	AN16	AN18	AN19	AN24	AN25	W		
V	P23.0	VEXT																		AN26	AN27	V	
U	P23.2	P23.1	U	VSS	P32.7	P32.6	P33.15	P34.5	P34.3	P34.1	AN1	AN3	AN7	AN9	AN14	AN17	NC	U		AN28	AN29	U	
T	P23.4	P23.3	T	P23.5	VSS	P32.5	P33.14	P34.4	P34.2	VEVRSB	AN0	AN4	AN6	AN12	AN15	AN22	AN30	T	VAGND2	VAREF2	T		
R	P22.2	P22.3	R	P23.6	P23.7	Top-View															AN23	AN31	R
P	P22.0	P22.1	P	P22.5	P22.4			VDD	VSS	VSS (AGBT TX0P)	VSS (AGBT TX0N)	VSS	VDD			AN34	AN32	P		AN37	AN39	P	
N	VDDP3	VDD	N	P22.7	P22.6		VDD		VSS	VSS	VSS	VSS		VDD		AN38	AN36	N		AN45	AN44	N	
M	XTAL1	XTAL2	M	P22.9	P22.8		VSS	VSS		VSS	VSS		VSS	VSS		AN40	AN41	M		AN47	AN46	M	
L	VSS	TRST	L	P22.11	P22.10		VSS (AGBT ERR)	VSS	VSS	VSS	VSS	VSS	VSS	VSS (AGBT CLKN)		AN42	AN43	L		P00.12	P00.11	L	
K	P21.4	P21.2	K	P21.0	TMS		NC (VDDPSB)	VSS	VSS	VSS	VSS	VSS	VSS	VSS (AGBT CLKP)		P00.10	P00.8	K		P00.9	P00.7	K	
J	P21.5	P21.3	J	P21.1	TCK		VSS	VSS		VSS	VSS		VSS	VSS		P01.7	P00.6	J		P00.5	P00.4	J	
H	P20.0	P20.2	H	P21.6	P21.7		VDD		VSS	VSS	VSS	VSS		VDD (VDDSB)		P01.5	P01.6	H		P00.3	P00.2	H	
G	P20.3	P20.1	G	PORST	ESR1			VDD	VSS	VSS	VSS	VSS	VDD (VDDSB)			P01.3	P01.4	G		P00.1	P00.0	G	
F	P20.8	P20.7	F	P20.6	ESR0											P02.10	P02.11	F		P02.7	P02.8	F	
E	P20.11	P20.10	E	P20.9	VSS	VDDFL3	P15.5	P14.2	P12.0	P12.1	P11.0	P11.1	P11.7	P11.8	P11.13	VSS	P02.9	E		P02.5	P02.6	E	
D	P20.13	P20.12	D	VSS	VDDFL3	P15.7	P15.8	P14.7	P14.9	P14.10	P11.4	P11.6	P11.5	P11.14	P11.15	VFLEX	VSS	D		P02.3	P02.4	D	
C	P20.14	P15.2																		P02.1	P02.2	C	
B	P15.0	VSS	VDDP3	P15.3	P14.0	P14.4	P14.3	P14.6	P13.0	P13.2	P11.3	P11.10	P11.12	P10.1	P10.4	P10.5	P10.8	VEXT	VSS	P02.0		B	
A	VSS	VDDP3	P15.1	P15.4	P15.6	P14.1	P14.5	P14.8	P13.1	P13.3	P11.2	P11.9	P11.11	P10.0	P10.3	P10.2	P10.6	P10.7	VEXT	NC		A	
	20	19	18	17	16	15	14	13	12	11	10	9	8	7	6	5	4	3	2	1			

Figure 2-3 TC297x Logic Symbol for the package variant BGA292.

2.3.1 TC297x BGA292 Package Variant Pin Configuration

Table 2-53 Port 00 Functions

Pin	Symbol	Ctrl	Type	Function
G1	P00.0	I	MP / PU1 / VEXT	General-purpose input
	TIN9			GTM input
	CTRAPA			CCU61 input
	T12HRE			CCU60 input
	INJ00			MSC0 input
	CIFD9			CIF input
	P00.0			O0
	TOUT9	O1		GTM output
	ASCLK3	O2		ASCLIN3 output
	ATX3	O3		ASCLIN3 output
	–	O4		Reserved
	TXDCAN1	O5		CAN node 1 output
	–	O6		Reserved
	COU63	O7		CCU60 output
	ETHMDIOA	HWOUT		ETH input/output

Package and Pinning Definitions TC297x Pin Definition and Functions:
Table 2-53 Port 00 Functions (cont'd)

Pin	Symbol	Ctrl	Type	Function
G2	P00.1	I	LP / PU1 / VEXT	General-purpose input
	TIN10			GTM input
	ARX3E			ASCLIN3 input
	RXDCAN1D			CAN node 1 input
	PSIRX0A			PSI5 input
	SENT0B			SENT input
	CC60INB			CCU60 input
	CC60INA			CCU61 input
	DSCIN5A			DSADC channel 5 input
	DS5NA			DSADC positive analog input of channel channel 5, pin A
	DSCIN7B			DSADC channel 7 input
	VADCG7.5			VADC analog input channel 5 of group 7
	CIFD10			CIF input
	P00.1			O0
	TOUT10	O1	GTM output	
	ATX3	O2	ASCLIN3 output	
	-	O3	Reserved	
	DSCOUT5	O4	DSADC channel 5 output	
	DSCOUT7	O5	DSADC channel 7 output	
	SPC0	O6	SENT output	
CC60	O7	CCU61 output		
H1	P00.2	I	LP / PU1 / VEXT	General-purpose input
	TIN11			GTM input
	SENT1B			SENT input
	DSDIN5A			DSADC channel 5 input
	DSDIN7B			DSADC channel 7 input
	DS5PA			DSADC negative analog input of channel 5, pin A
	VADCG7.4			VADC analog input channel 4 of group 7
	CIFD11			CIF input
	P00.2			O0
	TOUT11	O1	GTM output	
	ASCLK3	O2	ASCLIN3 output	
	TXDCANr1	O3	CAN node 1 output (MultiCANr+)	
	PSITX0	O4	PSI5 output	
	TXDCAN3	O5	CAN node 3 output	
	SLSO34	O6	QSPI3 output	
	COUT60	O7	CCU61 output	

Package and Pinning Definitions TC297x Pin Definition and Functions:

Table 2-53 Port 00 Functions (cont'd)

Pin	Symbol	Ctrl	Type	Function	
H2	P00.3	I	LP / PU1 / VEXT	General-purpose input	
	TIN12			GTM input	
	RXDCAN3A			CAN node 3 input	
	RXDCANr1A			CAN node 1 input (MultiCANr+)	
	PSIRX1A			PSI5 input	
	PSISRXA			PSI5-S input	
	SENT2B			SENT input	
	CC61INB			CCU60 input	
	CC61INA			CCU61 input	
	DSCIN3A			DSADC channel 3 input	
	VADCG7.3			VADC analog input channel 3 of group 7	
	DSITR5F			DSADC channel 5 input	
	CIFD12			CIF input	
	P00.3	O0	General-purpose output		
	TOUT12	O1	GTM output		
	ASLSO3	O2	ASCLIN3 output		
	–	O3	Reserved		
	DSCOUT3	O4	DSADC channel 3 output		
	–	O5	Reserved		
	SPC2	O6	SENT output		
CC61	O7	CCU61 output			
J1	P00.4	I	LP / PU1 / VEXT	General-purpose input	
	TIN13			GTM input	
	REQ7			SCU input	
	SENT3B			SENT input	
	DSDIN3A			DSADC channel 3 input	
	DSSGNA			DSADC channel input	
	VADCG7.2			VADC analog input channel 2 of group 7	
	CIFD13			CIF input	
	P00.4			O0	General-purpose output
	TOUT13			O1	GTM output
	PSISTX			O2	PSI5-S output
	–			O3	Reserved
	PSITX1			O4	PSI5 output
	VADCG4BFL0	O5	VADC output		
	SPC3	O6	SENT output		
	COUT61	O7	CCU61 output		

Package and Pinning Definitions TC297x Pin Definition and Functions:
Table 2-53 Port 00 Functions (cont'd)

Pin	Symbol	Ctrl	Type	Function
J2	P00.5	I	LP / PU1 / VEXT	General-purpose input
	TIN14			GTM input
	PSIRX2A			PSI5 input
	SENT4B			SENT input
	CC62INB			CCU60 input
	CC62INA			CCU61 input
	DSCIN2A			DSADC channel 2 input
	VADCG7.1			VADC analog input channel 1 of group 7
	CIFD14			CIF input
	P00.5	O0		General-purpose output
	TOUT14	O1		GTM output
	DSCGPWMN	O2		DSADC output
	SLSO33	O3		QSPI3 output
	DSCOUT2	O4		DSADC channel 2 output
	VADCG4BFL1	O5		VADC output
	SPC4	O6		SENT output
	CC62	O7		CCU61 output
J4	P00.6	I	LP / PU1 / VEXT	General-purpose input
	TIN15			GTM input
	SENT5B			SENT input
	DSDIN2A			DSADC channel 2 input A
	VADCG7.0			VADC analog input channel 0 of group 7 (with pull down diagnostics)
	DSITR4F			DSADC channel 4 input F
	CIFD15			CIF input
	P00.6	O0		General-purpose output
	TOUT15	O1		GTM output
	DSCGPWMP	O2		DSADC output
	VADCG4BFL2	O3		VADC output
	PSITX2	O4		PSI5 output
	VADCEMUX10	O5		VADC output
	SPC5	O6		SENT output
	COU62	O7		CCU61 output

Package and Pinning Definitions TC297x Pin Definition and Functions:

Table 2-53 Port 00 Functions (cont'd)

Pin	Symbol	Ctrl	Type	Function	
K1	P00.7	I	LP / PU1 / VEXT	General-purpose input	
	TIN16			GTM input	
	SENT6B			SENT input	
	CC60INC			CCU61 input	
	CCPOS0A			CCU61 input	
	T12HRB			CCU60 input	
	T2INA			GPT120 input	
	DSCIN4A			DSADC channel 4 input A	
	DS4NA			DSADC negative analog input channel 4, pin A	
	VADCG6.5			VADC analog input channel 5 of group 6	
	CIFCLK			CIF input	
	P00.7			O0	General-purpose output
	TOUT16			O1	GTM output
	–	O2	Reserved		
	VADCG4BFL3	O3	VADC output		
	DSCOUT4	O4	DSADC channel 4 output		
	VADCEMUX11	O5	VADC output		
	SPC6	O6	SENT output		
	CC60	O7	CCU61 output		
K4	P00.8	I	LP / PU1 / VEXT	General-purpose input	
	TIN17			GTM input	
	SENT7B			SENT input	
	CC61INC			CCU61 input	
	CCPOS1A			CCU61 input	
	T13HRB			CCU60 input	
	T2EUDA			GPT120 input	
	DSDIN4A			DSADC channel 4 input A	
	DS4PA			DSADC positive analog input of channel 4, pin A	
	VADCG6.4			VADC analog input channel 4 of group 6	
	CIFVSNC			CIF input	
	P00.8			O0	General-purpose output
	TOUT17			O1	GTM output
	SLSO36	O2	QSPI3 output		
	–	O3	Reserved		
	–	O4	Reserved		
	VADCEMUX12	O5	VADC output		
	SPC7	O6	SENT output		
	CC61	O7	CCU61 output		

Package and Pinning Definitions TC297x Pin Definition and Functions:

Table 2-53 Port 00 Functions (cont'd)

Pin	Symbol	Ctrl	Type	Function
K2	P00.9	I	LP / PU1 / VEXT	General-purpose input
	TIN18			GTM input
	SENT8B			SENT input
	CC62INC			CCU61 input
	CCPOS2A			CCU61 input
	T13HRC			CCU60 input
	T12HRC			CCU60 input
	T4EUDA			GPT120 input
	DSCIN1A			DSADC channel 1 input A
	VADCG6.3			VADC analog input channel 3 of group 6
	DSITR3F			DSADC channel 3 input F
	CIFHSNC			CIF input
	P00.9			O0
	TOUT18	O1		GTM output
	SLSO37	O2		QSPI3 output
	ARTS3	O3		ASCLIN3 output
	DSCOUT1	O4		DSADC channel 1 output
	–	O5		Reserved
	SPC8	O6		SENT output
	CC62	O7		CCU61 output
K5	P00.10	I	LP / PU1 / VEXT	General-purpose input
	TIN19			GTM input
	SENT9B			SENT input
	DSDIN1A			DSADC channel 1 input A
	VADCG6.2			VADC analog input channel 2 of group 6
	P00.10	O0		General-purpose output
	TOUT19	O1		GTM output
	–	O2		Reserved
	–	O3		Reserved
	–	O4		Reserved
	–	O5		Reserved
	SPC9	O6		SENT output
	COU63	O7		CCU61 output

Package and Pinning Definitions TC297x Pin Definition and Functions:

Table 2-53 Port 00 Functions (cont'd)

Pin	Symbol	Ctrl	Type	Function
L1	P00.11	I	LP / PU1 / VEXT	General-purpose input
	TIN20			GTM input
	CTRAPA			CCU60 input
	T12HRE			CCU61 input
	DSCIN0A			DSADC channel 0 input A
	VADCG6.1			VADC analog input channel 1 of group 6
	P00.11			O0
	TOUT20	O1		GTM output
	—	O2		Reserved
	—	O3		Reserved
	DSCOUT0	O4		DSADC channel 0 output
	—	O5		Reserved
	—	O6		Reserved
	—	O7		Reserved
L2	P00.12	I	LP / PU1 / VEXT	General-purpose input
	TIN21			GTM input
	ACTS3A			ASCLIN3 input
	DSDIN0A			DSADC channel 0 input A
	VADCG6.0			VADC analog input channel 0 of group 6
	P00.12	O0		General-purpose output
	TOUT21	O1		GTM output
	—	O2		Reserved
	—	O3		Reserved
	—	O4		Reserved
	—	O5		Reserved
	—	O6		Reserved
	COUT63	O7		CCU61 output

Package and Pinning Definitions TC297x Pin Definition and Functions:

Table 2-54 Port 01 Functions

Pin	Symbol	Ctrl	Type	Function
G5	P01.3	I	LP / PU1 / VEXT	General-purpose input
	TIN111			GTM input
	SLSI3B			QSPI3 input
	DSITR7F			DSADC channel 7 input F
	P01.3	O0		General-purpose output
	TOUT111	O1		GTM output
	—	O2		Reserved
	—	O3		Reserved
	SLSO39	O4		QSPI3 output
	TXDCAN1	O5		CAN node 1 output
	—	O6		Reserved
	—	O7		Reserved
G4	P01.4	I	LP / PU1 / VEXT	General-purpose input
	TIN112			GTM input
	RXDCAN1C			CAN node 1 input
	DSITR7E			DSADC channel 7 input E
	P01.4	O0		General-purpose output
	TOUT112	O1		GTM output
	—	O2		Reserved
	—	O3		Reserved
	SLSO310	O4		QSPI3 output
	—	O5		Reserved
	—	O6		Reserved
	—	O7		Reserved
H5	P01.5	I	LP / PU1 / VEXT	General-purpose input
	TIN113			GTM input
	MRST3C			QSPI3 input
	DSCIN8A			DSADC channel 8 input A
	P01.5	O0		General-purpose output
	TOUT113	O1		GTM output
	—	O2		Reserved
	—	O3		Reserved
	MRST3	O4		QSPI3 output
	—	O5		Reserved
	DSCOUT8	O6		DSADC channel 8 output
	—	O7		Reserved

Package and Pinning Definitions TC297x Pin Definition and Functions:

Table 2-54 Port 01 Functions (cont'd)

Pin	Symbol	Ctrl	Type	Function
H4	P01.6	I	MP / PU1 / VEXT	General-purpose input
	TIN114			GTM input
	MTSR3C			QSPI3 input
	DSDIN8A			DSADC channel 8 input A
	P01.6	O0		General-purpose output
	TOUT114	O1		GTM output
	–	O2		Reserved
	–	O3		Reserved
	MTSR3	O4		QSPI3 output
	–	O5		Reserved
	–	O6		Reserved
	–	O7		Reserved
	J5	P01.7		I
TIN115		GTM input		
SCLK3C		QSPI3 input		
DSITR8F		DSADC channel 8 input F		
P01.7		O0	General-purpose output	
TOUT115		O1	GTM output	
–		O2	Reserved	
–		O3	Reserved	
SCLK3		O4	QSPI3 output	
–		O5	Reserved	
–		O6	Reserved	
–		O7	Reserved	

Package and Pinning Definitions TC297x Pin Definition and Functions:

Table 2-55 Port 02 Functions

Pin	Symbol	Ctrl	Type	Function
B1	P02.0	I	MP+ / PU1 / VEXT	General-purpose input
	TIN0			GTM input
	REQ6			SCU input
	ARX2G			ASCLIN2 input
	CC60INA			CCU60 input
	CC60INB			CCU61 input
	CIFD0			CIF input
	P02.0			O0
	TOUT0	O1		GTM output
	ATX2	O2		ASCLIN2 output
	SLSO31	O3		QSPI3 output
	DSCGPWMN	O4		DSADC output
	TXDCAN0	O5		CAN node 0 output
	TXD0A	O6		ERAY0 output
	CC60	O7		CCU60 output
	C2	P02.1		I
TIN1		GTM input		
REQ14		SCU input		
ARX2B		ASCLIN2 input		
RXDCAN0A		CAN node 0 input		
RXD0A2		ERAY0 input		
CIFD1		CIF input		
P02.1		O0	General-purpose output	
TOUT1		O1	GTM output	
SLSO47		O2	QSPI4 output	
SLSO32		O3	QSPI3 output	
DSCGPWMP		O4	DSADC output	
–		O5	Reserved	
–		O6	Reserved	
COUT60		O7	CCU60 output	

Package and Pinning Definitions TC297x Pin Definition and Functions:

Table 2-55 Port 02 Functions (cont'd)

Pin	Symbol	Ctrl	Type	Function
C1	P02.2	I	MP+ / PU1 / VEXT	General-purpose input
	TIN2			GTM input
	CC61INA			CCU60 input
	CC61INB			CCU61 input
	CIFD2			CIF input
	P02.2	O0		General-purpose output
	TOUT2	O1		GTM output
	ATX1	O2		ASCLIN1 output
	SLSO33	O3		QSPI3 output
	PSITX0	O4		PSI5 output
	TXDCAN2	O5		CAN node 2 output
	TXD0B	O6		ERAY0 output
	CC61	O7		CCU60 output
	D2	P02.3		I
TIN3		GTM input		
ARX1G		ASCLIN1 input		
RXDCAN2B		CAN node 2 input		
RXD0B2		ERAY0 input		
PSIRX0B		PSI5 input		
DSCIN5B		DSADC channel 5 input B		
SDI11		MSC1 input		
CIFD3		CIF input		
P02.3		O0	General-purpose output	
TOUT3		O1	GTM output	
ASLSO2		O2	ASCLIN2 output	
SLSO34		O3	QSPI3 output	
DSCOUT5		O4	DSADC channel 5 output	
—		O5	Reserved	
—		O6	Reserved	
COUT61		O7	CCU60 output	

Package and Pinning Definitions TC297x Pin Definition and Functions:

Table 2-55 Port 02 Functions (cont'd)

Pin	Symbol	Ctrl	Type	Function
D1	P02.4	I	MP+ / PU1 / VEXT	General-purpose input
	TIN4			GTM input
	SLSI3A			QSPI3 input
	ECTT1			TTCAN input
	RXDCAN0D			CAN node 0 input
	CC62INA			CCU60 input
	CC62INB			CCU61 input
	DSDIN5B			DSADC channel 5 input B
	SDA0A			I2C0 input
	CIFD4			CIF input
	P02.4			O0
	TOUT4	O1		GTM output
	ASCLK2	O2		ASCLIN2 output
	SLSO30	O3		QSPI3 output
	PSISCLK	O4		PSI5-S output
	SDA0	O5		I2C0 output
	TXEN0A	O6		ERAY0 output
	CC62	O7		CCU60 output
E2	P02.5	I	MP+ / PU1 / VEXT	General-purpose input
	TIN5			GTM input
	MRST3A			QSPI3 input
	ECTT2			TTCAN input
	PSIRX1B			PSI5 input
	PSISRXB			PSI5-S input
	SENT3C			SENT input
	DSCIN4B			DSADC channel 4 input B
	SCL0A			I2C0 input
	CIFD5			CIF input
	P02.5			O0
	TOUT5	O1		GTM output
	TXDCAN0	O2		CAN node 0 output
	MRST3	O3		QSPI3 output
	DSCOUT4	O4		DSADC channel 4 output
	SCL0	O5		I2C0 output
	TXEN0B	O6		ERAY0 output
	COU62	O7		CCU60 output

Package and Pinning Definitions TC297x Pin Definition and Functions:

Table 2-55 Port 02 Functions (cont'd)

Pin	Symbol	Ctrl	Type	Function	
E1	P02.6	I	MP / PU1 / VEXT	General-purpose input	
	TIN6			GTM input	
	MTSR3A			QSPI3 input	
	SENT2C			SENT input	
	CC60INC			CCU60 input	
	CCPOS0A			CCU60 input	
	T12HRB			CCU61 input	
	T3INA			GPT120 input	
	CIFD6			CIF input	
	DSDIN4B			DSADC channel 4 input B	
	DSITR5E			DSADC channel 5 input E	
	P02.6			O0	General-purpose output
	TOUT6			O1	GTM output
	PSISTX	O2	PSI5-S output		
	MTSR3	O3	QSPI3 output		
	PSITX1	O4	PSI5 output		
	VADCEMUX00	O5	VADC output		
	–	O6	Reserved		
	CC60	O7	CCU60 output		

Package and Pinning Definitions TC297x Pin Definition and Functions:

Table 2-55 Port 02 Functions (cont'd)

Pin	Symbol	Ctrl	Type	Function
F2	P02.7	I	MP / PU1 / VEXT	General-purpose input
	TIN7			GTM input
	SCLK3A			QSPI3 input
	PSIRX2B			PSI5 input
	SENT1C			SENT input
	CC61INC			CCU60 input
	CCPOS1A			CCU60 input
	T13HRB			CCU61 input
	T3EUDA			GPT120 input
	CIFD7			CIF input
	DSCIN3B			DSADC channel 3 input B
	DSITR4E			DSADC channel 4 input E
	P02.7			O0
	TOUT7	O1		GTM output
	–	O2		Reserved
	SCLK3	O3		QSPI3 output
	DSCOUT3	O4		DSADC channel 3 output
	VADCEMUX01	O5		VADC output
	SPC1	O6		SENT output
	CC61	O7		CCU60 output

Package and Pinning Definitions TC297x Pin Definition and Functions:

Table 2-55 Port 02 Functions (cont'd)

Pin	Symbol	Ctrl	Type	Function
F1	P02.8	I	LP / PU1 / VEXT	General-purpose input
	TIN8			GTM input
	SENT0C			SENT input
	CC62INC			CCU60 input
	CCPOS2A			CCU60 input
	T12HRC			CCU61 input
	T13HRC			CCU61 input
	T4INA			GPT120 input
	CIFD8			CIF input
	DSDIN3B			DSADC channel 3 input B
	DSITR3E			DSADC channel 3 input E
	P02.8	O0	General-purpose output	
	TOUT8	O1	GTM output	
	SLSO35	O2	QSPI3 output	
	–	O3	Reserved	
	PSITX2	O4	PSI5 output	
	VADCEMUX02	O5	VADC output	
ETHMDC	O6	ETH output		
CC62	O7	CCU60 output		
E4	P02.9	I	LP / PU1 / VEXT	General-purpose input
	TIN116			GTM input
	P02.9	O0		General-purpose output
	TOUT116	O1		GTM output
	ATX2	O2		ASCLIN2 output
	–	O3		Reserved
	–	O4		Reserved
	TXDCAN1	O5		CAN node 1 output
	–	O6		Reserved
	–	O7		Reserved

Package and Pinning Definitions TC297x Pin Definition and Functions:
Table 2-55 Port 02 Functions (cont'd)

Pin	Symbol	Ctrl	Type	Function
F5	P02.10	I	LP / PU1 / VEXT	General-purpose input
	TIN117			GTM input
	ARX2C			ASCLIN2 input
	RXDCAN1E			CAN node 1 input
	P02.10	O0		General-purpose output
	TOUT117	O1		GTM output
	—	O2		Reserved
	—	O3		Reserved
	—	O4		Reserved
	—	O5		Reserved
	—	O6		Reserved
	—	O7		Reserved
F4	P02.11	I	LP / PU1 / VEXT	General-purpose input
	TIN118			GTM input
	P02.11	O0		General-purpose output
	TOUT118	O1		GTM output
	—	O2		Reserved
	—	O3		Reserved
	—	O4		Reserved
	—	O5		Reserved
	—	O6		Reserved
	—	O7		Reserved

Table 2-56 Port 10 Functions

Pin	Symbol	Ctrl	Type	Function
A7	P10.0	I	LP / PU1 / VEXT	General-purpose input
	TIN102			GTM input
	T6EUDB			GPT120 input
	P10.0	O0		General-purpose output
	TOUT102	O1		GTM output
	—	O2		Reserved
	SLSO110	O3		QSPI1 output
	—	O4		Reserved
	VADCG6BFL0	O5		VADC output
	—	O6		Reserved
	—	O7		Reserved

Package and Pinning Definitions TC297x Pin Definition and Functions:

Table 2-56 Port 10 Functions (cont'd)

Pin	Symbol	Ctrl	Type	Function
B7	P10.1	I	MP+ / PU1 / VEXT	General-purpose input
	TIN103			GTM input
	MRST1A			QSPI1 input
	T5EUDB			GPT120 input
	P10.1	O0		General-purpose output
	TOUT103	O1		GTM output
	MTRSR1	O2		QSPI1 output
	MRST1	O3		QSPI1 output
	EN01	O4		MSC0 output
	VADCG6BFL1	O5		VADC output
	END03	O6		MSC0 output
	-	O7		Reserved
	A5	P10.2		I
TIN104		GTM input		
SCLK1A		QSPI1 input		
T6INB		GPT120 input		
REQ2		SCU input		
RXDCAN2E		CAN node 2 input		
SDI01		MSC0 input		
P10.2		O0	General-purpose output	
TOUT104		O1	GTM output	
-		O2	Reserved	
SCLK1		O3	QSPI1 output	
EN00		O4	MSC0 output	
VADCG6BFL2		O5	VADC output	
END02		O6	MSC0 output	
-		O7	Reserved	

Package and Pinning Definitions TC297x Pin Definition and Functions:

Table 2-56 Port 10 Functions (cont'd)

Pin	Symbol	Ctrl	Type	Function
A6	P10.3	I	MP / PU1 / VEXT	General-purpose input
	TIN105			GTM input
	MTSR1A			QSPI1 input
	REQ3			SCU input
	T5INB			GPT120 input
	P10.3			O0
	TOUT105	O1		GTM output
	VADCG6BFL3	O2		VADC output
	MTSR1	O3		QSPI1 output
	EN00	O4		MSC0 output
	END02	O5		MSC0 output
	TXDCAN2	O6		CAN node 2 output
	–	O7		Reserved
	B6	P10.4		I
TIN106		GTM input		
MTSR1C		QSPI1 input		
CCPOS0C		CCU60 input		
T3INB		GPT120 input		
P10.4		O0	General-purpose output	
TOUT106		O1	GTM output	
–		O2	Reserved	
SLSO18		O3	QSPI1 output	
MTSR1		O4	QSPI1 output	
EN00		O5	MSC0 output	
END02		O6	MSC0 output	
–		O7	Reserved	

Package and Pinning Definitions TC297x Pin Definition and Functions:

Table 2-56 Port 10 Functions (cont'd)

Pin	Symbol	Ctrl	Type	Function
B5	P10.5	I	LP / PU1 / VEXT	General-purpose input
	TIN107			GTM input
	HWCFG4			SCU input
	RXDCANr0A			CAN node 0 input (MultiCANr+)
	INJ01			MSC0 input
	P10.5			O0
	TOUT107	O1		GTM output
	ATX2	O2		ASCLIN2 output
	SLSO38	O3		QSPI3 output
	SLSO19	O4		QSPI1 output
	T6OUT	O5		GPT120 output
	ASLSO2	O6		ASCLIN2 output
	PSITX3	O7		PSI5 output
	A4	P10.6		I
TIN108		GTM input		
ARX2D		ASCLIN2 input		
MTSR3B		QSPI3 input		
PSIRX3C		PSI5 input		
HWCFG5		SCU input		
P10.6		O0	General-purpose output	
TOUT108		O1	GTM output	
ASCLK2		O2	ASCLIN2 output	
MTSR3		O3	QSPI3 output	
T3OUT		O4	GPT120 output	
TXDCANr0		O5	CAN node 0 output (MultiCANr+)	
MRST1		O6	QSPI1 output	
VADCG7BFL0		O7	VADC output	

Package and Pinning Definitions TC297x Pin Definition and Functions:
Table 2-56 Port 10 Functions (cont'd)

Pin	Symbol	Ctrl	Type	Function
A3	P10.7	I	LP / PU1 / VEXT	General-purpose input
	TIN109			GTM input
	ACTS2A			ASCLIN2 input
	MRST3B			QSPI3 input
	REQ4			SCU input
	CCPOS1C			CCU60 input
	T3EUDB			GPT120 input
	P10.7			O0
	TOUT109	O1		GTM output
	–	O2		Reserved
	MRST3	O3		QSPI3 output
	VADCG7BFL1	O4		VADC output
	TXDCANr0	O5		CAN node 0 output (MultiCANr+)
	–	O6		Reserved
	–	O7		Reserved
B4	P10.8	I	LP / PU1 / VEXT	General-purpose input
	TIN110			GTM input
	SCLK3B			QSPI3 input
	REQ5			SCU input
	CCPOS2C			CCU60 input
	T4INB			GPT120 input
	RXDCANr0B			CAN node 0 input (MultiCANr+)
	P10.8			O0
	TOUT110	O1		GTM output
	ARTS2	O2		ASCLIN2 output
	SCLK3	O3		QSPI3 output
	–	O4		Reserved
	–	O5		Reserved
	–	O6		Reserved
	–	O7		Reserved

Package and Pinning Definitions TC297x Pin Definition and Functions:

Table 2-57 Port 11 Functions

Pin	Symbol	Ctrl	Type	Function
E10	P11.0	I	MP+ / PU1 / VFLEX	General-purpose input
	TIN119			GTM input
	ARX3B			ASCLIN3 input
	P11.0	O0		General-purpose output
	TOUT119	O1		GTM output
	ATX3	O2		ASCLIN3 output
	–	O3		Reserved
	–	O4		Reserved
	–	O5		Reserved
	ETHTXD3	O6		ETH output
	–	O7		Reserved
E9	P11.1	I	MP+ / PU1 / VFLEX	General-purpose input
	TIN120			GTM input
	P11.1			O0
	TOUT120	O1		GTM output
	ASCLK3	O2		ASCLIN3 output
	ATX3	O3		ASCLIN3 output
	–	O4		Reserved
	–	O5		Reserved
	ETHTXD2	O6		ETH output
	–	O7		Reserved
	A10	P11.2		I
TIN95		GTM input		
P11.2		O0	General-purpose output	
TOUT95		O1	GTM output	
END03		O2	MSC0 output	
SLSO05		O3	QSPI0 output	
SLSO15		O4	QSPI1 output	
EN01		O5	MSC0 output	
ETHTXD1		O6	ETH output	
COU63		O7	CCU60 output	

Package and Pinning Definitions TC297x Pin Definition and Functions:

Table 2-57 Port 11 Functions (cont'd)

Pin	Symbol	Ctrl	Type	Function
B10	P11.3	I	MPR / PU1 / VFLEX	General-purpose input
	TIN96			GTM input
	MRST1B			QSPI1 input
	SDI03			MSC0 input
	P11.3	O0		General-purpose output
	TOUT96	O1		GTM output
	–	O2		Reserved
	MRST1	O3		QSPI1 output
	TXD0A	O4		ERAY0 output
	–	O5		Reserved
	ETHTXD0	O6		ETH output
	COUT62	O7		CCU60 output
D10	P11.4	I	MP+ / PU1 / VFLEX	General-purpose input
	TIN121			GTM input
	ETHRXCLKB			ETH input
	P11.4			General-purpose output
	TOUT121	O1		GTM output
	ASCLK3	O2		ASCLIN3 output
	–	O3		Reserved
	–	O4		Reserved
	–	O5		Reserved
	ETHTXER	O6		ETH output
	–	O7		Reserved
	D8	P11.5		I
TIN122		GTM input		
ETHTXCLKA		ETH input		
P11.5		General-purpose output		
TOUT122		O1	GTM output	
–		O2	Reserved	
–		O3	Reserved	
–		O4	Reserved	
–		O5	Reserved	
–		O6	Reserved	
–		O7	Reserved	

Package and Pinning Definitions TC297x Pin Definition and Functions:

Table 2-57 Port 11 Functions (cont'd)

Pin	Symbol	Ctrl	Type	Function
D9	P11.6	I	MPR / PU1 / VFLEX	General-purpose input
	TIN97			GTM input
	SCLK1B			QSPI1 input
	P11.6	O0		General-purpose output
	TOUT97	O1		GTM output
	TXEN0B	O2		ERAY0 output
	SCLK1	O3		QSPI1 output
	TXEN0A	O4		ERAY0 output
	FCLP0	O5		MSC0 output
	ETHTXEN	O6		ETH output
	COU61	O7		CCU60 output
E8	P11.7	I	LP / PU1 / VFLEX	General-purpose input
	TIN123			GTM input
	ETHRXD3			ETH input
	P11.7	O0		General-purpose output
	TOUT123	O1		GTM output
	–	O2		Reserved
	–	O3		Reserved
	–	O4		Reserved
	–	O5		Reserved
	–	O6		Reserved
	–	O7		Reserved
E7	P11.8	I	LP / PU1 / VFLEX	General-purpose input
	TIN124			GTM input
	ETHRXD2			ETH input
	P11.8	O0		General-purpose output
	TOUT124	O1		GTM output
	–	O2		Reserved
	–	O3		Reserved
	–	O4		Reserved
	–	O5		Reserved
	–	O6		Reserved
	–	O7		Reserved

Package and Pinning Definitions TC297x Pin Definition and Functions:
Table 2-57 Port 11 Functions (cont'd)

Pin	Symbol	Ctrl	Type	Function
A9	P11.9	I	MP+ / PU1 / VFLEX	General-purpose input
	TIN98			GTM input
	MTSR1B			QSPI1 input
	RXD0A1			ERAY0 input
	ETHRXD1			ETH input
	P11.9			O0
	TOUT98	O1		GTM output
	–	O2		Reserved
	MTSR1	O3		QSPI1 output
	–	O4		Reserved
	SOP0	O5		MSC0 output
	–	O6		Reserved
	COUT60	O7		CCU60 output
	B9	P11.10		I
TIN99		GTM input		
REQ12		SCU input		
ARX1E		ASCLIN1 input		
SLS1A		QSPI1 input		
RXDCAN3D		CAN node 3 input		
RXD0B1		ERAY0 input		
ETHRXD0		ETH input		
SDI00		MSC0 input		
P11.10		O0	General-purpose output	
TOUT99		O1	GTM output	
–		O2	Reserved	
SLSO03		O3	QSPI0 output	
SLSO13		O4	QSPI1 output	
–		O5	Reserved	
–		O6	Reserved	
CC62		O7	CCU60 output	

Package and Pinning Definitions TC297x Pin Definition and Functions:
Table 2-57 Port 11 Functions (cont'd)

Pin	Symbol	Ctrl	Type	Function
A8	P11.11	I	MP+ / PU1 / VFLEX	General-purpose input
	TIN100			GTM input
	ETHCRSDVA			ETH input
	ETHRXDVA			ETH input
	ETHCRSB			ETH input
	P11.11	O0		General-purpose output
	TOUT100	O1		GTM output
	END02	O2		MSC0 output
	SLSO04	O3		QSPI0 output
	SLSO14	O4		QSPI1 output
	EN00	O5		MSC0 output
	TXEN0B	O6		ERAY0 output
	CC61	O7		CCU60 output
B8	P11.12	I	MPR / PU1 / VFLEX	General-purpose input
	TIN101			GTM input
	ETHREFCLK			ETH input
	ETHTXCLKB			ETH input (Not for productive purposes)
	ETHRXCLKA			ETH input (Not for productive purposes)
	P11.12	O0		General-purpose output
	TOUT101	O1		GTM output
	ATX1	O2		ASCLIN1 output
	GTMCLK2	O3		GTM output
	TXD0B	O4		ERAY0 output
	TXDCAN3	O5		CAN node 3 output
	EXTCLK1	O6		SCU output
	CC60	O7		CCU60 output

Package and Pinning Definitions TC297x Pin Definition and Functions:

Table 2-57 Port 11 Functions (cont'd)

Pin	Symbol	Ctrl	Type	Function
E6	P11.13	I	LP / PU1 / VFLEX	General-purpose input
	TIN125			GTM input
	ETHRXERA			ETH input
	SDA1A			I2C1 input
	P11.13	O0		General-purpose output
	TOUT125	O1		GTM output
	–	O2		Reserved
	–	O3		Reserved
	–	O4		Reserved
	–	O5		Reserved
	SDA1	O6		I2C1 output
	–	O7		Reserved
D7	P11.14	I	LP / PU1 / VFLEX	General-purpose input
	TIN126			GTM input
	ETHCRSDVB			ETH input
	ETHRXDVB			ETH input
	ETHCRSA	ETH input		
	SCL1A	I2C1 input		
	P11.14	O0		General-purpose output
	TOUT126	O1		GTM output
	–	O2		Reserved
	–	O3		Reserved
	–	O4		Reserved
	–	O5		Reserved
SCL1	O6	I2C1 output		
–	O7	Reserved		
D6	P11.15	I	LP / PU1 / VFLEX	General-purpose input
	TIN127			GTM input
	ETHCOL			ETH input
	P11.15			O0
	TOUT127	O1		GTM output
	–	O2		Reserved
	–	O3		Reserved
	–	O4		Reserved
	–	O5		Reserved
	–	O6		Reserved
	–	O7		Reserved

Package and Pinning Definitions TC297x Pin Definition and Functions:

Table 2-58 Port 12 Functions

Pin	Symbol	Ctrl	Type	Function
E12	P12.0	I	LP / PU1 / VFLEX	General-purpose input
	TIN128			GTM input
	ETHRXCLKC			ETH input
	RXDCAN0C			CAN node 0 input
	P12.0	O0		General-purpose output
	TOUT128	O1		GTM output
	—	O2		Reserved
	—	O3		Reserved
	—	O4		Reserved
	—	O5		Reserved
	ETHMDC	O6		ETH output
	—	O7		Reserved
E11	P12.1	I	LP / PU1 / VFLEX	General-purpose input
	TIN129			GTM input
	P12.1	O0		General-purpose output
	TOUT129	O1		GTM output
	ASLSO3	O2		ASCLIN3 output
	—	O3		Reserved
	—	O4		Reserved
	TXDCAN0	O5		CAN node 0 output
	—	O6		Reserved
	—	O7		Reserved
	ETHMDIOC	HWOUT		ETH input/output

Table 2-59 Port 13 Functions

Pin	Symbol	Ctrl	Type	Function
B12	P13.0	I	LVDSM_N / PU1 / VEXT	General-purpose input
	TIN91			GTM input
	P13.0	O0		General-purpose output
	TOUT91	O1		GTM output
	END03	O2		MSC0 output
	SCLK2N	O3		QSPI2 output (LVDS)
	EN01	O4		MSC0 output
	FCLN0	O5		MSC0 output (LVDS)
	FCLND0	O6		MSC0 output (LVDS)
	—	O7		Reserved

Package and Pinning Definitions TC297x Pin Definition and Functions:

Table 2-59 Port 13 Functions (cont'd)

Pin	Symbol	Ctrl	Type	Function
A12	P13.1	I	LVDSM_P / PU1 / VEXT	General-purpose input
	TIN92			GTM input
	SCL0B			I2C0 input
	P13.1	O0		General-purpose output
	TOUT92	O1		GTM output
	–	O2		Reserved
	SCLK2P	O3		QSPI2 output (LVDS)
	–	O4		Reserved
	FCLP0	O5		MSC0 output (LVDS)
	SCL0	O6		I2C0 output
	–	O7		Reserved
	B11	P13.2		I
TIN93		GTM input		
CAPINA		GPT120 input		
SDA0B		O0	I2C0 input	
P13.2			General-purpose output	
TOUT93			GTM output	
–		O2	Reserved	
MTSR2N		O3	QSPI2 output (LVDS)	
FCLP0		O4	MSC0 output	
SON0		O5	MSC0 output (LVDS)	
SDA0		O6	I2C0 output	
SOND0		O7	MSC0 output (LVDS)	
A11	P13.3	I	LVDSM_P / PU1 / VEXT	General-purpose input
	TIN94			GTM input
	P13.3	O0		General-purpose output
	TOUT94	O1		GTM output
	–	O2		Reserved
	MTSR2P	O3		QSPI2 output (LVDS)
	–	O4		Reserved
	SOP0	O5		MSC0 output (LVDS)
	–	O6		Reserved
	–	O7		Reserved

Package and Pinning Definitions TC297x Pin Definition and Functions:

Table 2-60 Port 14 Functions

Pin	Symbol	Ctrl	Type	Function	
B16	P14.0	I	MP+ / PU1 / VEXT	General-purpose input	
	TIN80			GTM input	
	SENT12D			SENT input	
	P14.0	O0		General-purpose output	
	TOUT80	O1		GTM output	
	ATX0	O2		ASCLIN0 output Recommended as Boot loader pin	
	TXD0A	O3		ERAY0 output	
	TXD0B	O4		ERAY0 output	
	TXDCAN1	O5		CAN node 1 output Used for single pin DAP (SPD) function	
	ASCLK0	O6		ASCLIN0 output	
	COU62	O7		CCU60 output	
A15	P14.1	I	MP / PU1 / VEXT	General-purpose input	
	TIN81			GTM input	
	REQ15			SCU input	
	SENT13D			SENT input	
	ARX0A			ASCLIN0 input Recommended as Boot loader pin	
	RXDCAN1B			CAN node 1 input Used for single pin DAP (SPD) function	
	RXD0A3			ERAY0 input	
	RXD0B3			ERAY0 input	
	EVRWUPA			SCU input	
	P14.1			O0	General-purpose output
	TOUT81			O1	GTM output
	ATX0	O2		ASCLIN0 output Recommended as Boot loader pin.	
	–	O3		Reserved	
	–	O4		Reserved	
	–	O5		Reserved	
	–	O6		Reserved	
	COU63	O7		CCU60 output	

Package and Pinning Definitions TC297x Pin Definition and Functions:

Table 2-60 Port 14 Functions (cont'd)

Pin	Symbol	Ctrl	Type	Function		
E13	P14.2	I	LP / PU1 / VEXT	General-purpose input		
	TIN82			GTM input		
	HWCFG2 EVR13			SCU input Latched at cold power on reset to decide EVR13 activation.		
	P14.2	O0		General-purpose output		
	TOUT82	O1		GTM output		
	ATX2	O2		ASCLIN2 output		
	SLSO21	O3		QSPI2 output		
	–	O4		Reserved		
	–	O5		Reserved		
	ASCLK2	O6		ASCLIN2 output		
	–	O7		Reserved		
	B14	P14.3		I	LP / PU1 / VEXT	General-purpose input
		TIN83				GTM input
ARX2A		ASCLIN2 input				
REQ10		SCU input				
HWCFG3_BMI		SCU input				
SDI02		MSC0 input				
P14.3		O0	General-purpose output			
TOUT83		O1	GTM output			
ATX2		O2	ASCLIN2 output			
SLSO23		O3	QSPI2 output			
ASLSO1		O4	ASCLIN1 output			
ASLSO3		O5	ASCLIN3 output			
–		O6	Reserved			
–	O7	Reserved				

Package and Pinning Definitions TC297x Pin Definition and Functions:

Table 2-60 Port 14 Functions (cont'd)

Pin	Symbol	Ctrl	Type	Function
B15	P14.4	I	LP / PU1 / VEXT	General-purpose input
	TIN84			GTM input
	HWCFG6			SCU input Latched at cold power on reset to decide default pad reset state (PU or HighZ).
	P14.4	O0		General-purpose output
	TOUT84	O1		GTM output
	—	O2		Reserved
	—	O3		Reserved
	—	O4		Reserved
	—	O5		Reserved
	—	O6		Reserved
—	O7	Reserved		
A14	P14.5	I	MP+ / PU1 / VEXT	General-purpose input
	TIN85			GTM input
	HWCFG1 EVR33			SCU input Latched at cold power on reset to decide EVR33 activation.
	P14.5	O0		General-purpose output
	TOUT85	O1		GTM output
	—	O2		Reserved
	—	O3		Reserved
	—	O4		Reserved
	—	O5		Reserved
	TXD0B	O6		ERAY0 output
TXD1B	O7	ERAY1 output		
B13	P14.6	I	MP+ / PU1 / VEXT	General-purpose input
	TIN86			GTM input
	HWCFG0 DCLDO			SCU input If EVR13 active, latched at cold power on reset to decide between LDO and SMPS mode.
	P14.6	O0		General-purpose output
	TOUT86	O1		GTM output
	—	O2		Reserved
	SLSO22	O3		QSPI2 output
	—	O4		Reserved
	—	O5		Reserved
	TXEN0B	O6		ERAY0 output
TXEN1B	O7	ERAY1 output		

Package and Pinning Definitions TC297x Pin Definition and Functions:

Table 2-60 Port 14 Functions (cont'd)

Pin	Symbol	Ctrl	Type	Function
D13	P14.7	I	LP / PU1 / VEXT	General-purpose input
	TIN87			GTM input
	RXD0B0			ERAY0 input
	RXD1B0			ERAY1 input
	P14.7	O0		General-purpose output
	TOUT87	O1		GTM output
	ARTS0	O2		ASCLIN0 output
	SLSO24	O3		QSPI2 output
	—	O4		Reserved
	—	O5		Reserved
	—	O6		Reserved
	—	O7		Reserved
A13	P14.8	I	LP / PU1 / VEXT	General-purpose input
	TIN88			GTM input
	ARX1D			ASCLIN1 input
	RXDCAN2D			CAN node 2 input
	RXD0A0			ERAY0 input
	RXD1A0			ERAY1 input
	P14.8	O0		General-purpose output
	TOUT88	O1		GTM output
	—	O2		Reserved
	—	O3		Reserved
	—	O4		Reserved
	—	O5		Reserved
—	O6	Reserved		
—	O7	Reserved		
D12	P14.9	I	MP+ / PU1 / VEXT	General-purpose input
	TIN89			GTM input
	ACTS0A			ASCLIN0 input
	P14.9	O0		General-purpose output
	TOUT89	O1		GTM output
	END03	O2		MSC0 output
	EN01	O3		MSC0 output
	—	O4		Reserved
	$\overline{\text{TXEN0B}}$	O5		ERAY0 output
	$\overline{\text{TXEN0A}}$	O6		ERAY0 output
	$\overline{\text{TXEN1A}}$	O7		ERAY1 output

Package and Pinning Definitions TC297x Pin Definition and Functions:

Table 2-60 Port 14 Functions (cont'd)

Pin	Symbol	Ctrl	Type	Function
D11	P14.10	I	MP+ / PU1 / VEXT	General-purpose input
	TIN90			GTM input
	P14.10	O0		General-purpose output
	TOUT90	O1		GTM output
	END02	O2		MSC0 output
	EN00	O3		MSC0 output
	ATX1	O4		ASCLIN1 output
	TXDCAN2	O5		CAN node 2 output
	TXD0A	O6		ERAY0 output
	TXD1A	O7		ERAY1 output

Table 2-61 Port 15 Functions

Pin	Symbol	Ctrl	Type	Function
B20	P15.0	I	LP / PU1 / VEXT	General-purpose input
	TIN71			GTM input
	P15.0	O0		General-purpose output
	TOUT71	O1		GTM output
	ATX1	O2		ASCLIN1 output
	SLSO013	O3		QSPI0 output
	–	O4		Reserved
	TXDCAN2	O5		CAN node 2 output
	ASCLK1	O6		ASCLIN1 output
	–	O7		Reserved
A18	P15.1	I	LP / PU1 / VEXT	General-purpose input
	TIN72			GTM input
	REQ16			SCU input
	ARX1A			ASCLIN1 input
	RXDCAN2A			CAN node 2 input
	SLSI2B			QSPI2 input
	EVRWUPB			SCU input
	P15.1			O0
	TOUT72	O1		GTM output
	ATX1	O2		ASCLIN1 output
	SLSO25	O3		QSPI2 output
	–	O4		Reserved
	–	O5		Reserved
	–	O6		Reserved
	–	O7		Reserved

Package and Pinning Definitions TC297x Pin Definition and Functions:

Table 2-61 Port 15 Functions (cont'd)

Pin	Symbol	Ctrl	Type	Function
C19	P15.2	I	MP / PU1 / VEXT	General-purpose input
	TIN73			GTM input
	SLSI2A			QSPI2 input
	MRST2E			QSPI2 input
	SENT10D			SENT input
	HSIC2INA			QSPI2 input
	P15.2			O0
	TOUT73	O1		GTM output
	ATX0	O2		ASCLIN0 output
	SLSO20	O3		QSPI2 output
	–	O4		Reserved
	TXDCAN1	O5		CAN node 1 output
	ASCLK0	O6		ASCLIN0 output
	–	O7		Reserved
B17	P15.3	I	MP / PU1 / VEXT	General-purpose input
	TIN74			GTM input
	ARX0B			ASCLIN0 input
	SCLK2A			QSPI2 input
	RXDCAN1A			CAN node 1 input
	HSIC2INB			QSPI2 input
	P15.3			O0
	TOUT74	O1		GTM output
	ATX0	O2		ASCLIN0 output
	SCLK2	O3		QSPI2 output
	END03	O4		MSC0 output
	EN01	O5		MSC0 output
	–	O6		Reserved
	–	O7		Reserved

Package and Pinning Definitions TC297x Pin Definition and Functions:

Table 2-61 Port 15 Functions (cont'd)

Pin	Symbol	Ctrl	Type	Function
A17	P15.4	I	MP / PU1 / VEXT	General-purpose input
	TIN75			GTM input
	MRST2A			QSPI2 input
	REQ0			SCU input
	SCL0C			I2C0 input
	SENT11D			SENT input
	P15.4			O0
	TOUT75	O1		GTM output
	ATX1	O2		ASCLIN1 output
	MRST2	O3		QSPI2 output
	–	O4		Reserved
	–	O5		Reserved
	SCL0	O6		I2C0 output
	CC62	O7		CCU60 output
E14	P15.5	I	MP / PU1 / VEXT	General-purpose input
	TIN76			GTM input
	ARX1B			ASCLIN1 input
	MTSR2A			QSPI2 input
	REQ13			SCU input
	SDA0C			I2C0 input
	P15.5			O0
	TOUT76	O1		GTM output
	ATX1	O2		ASCLIN1 output
	MTSR2	O3		QSPI2 output
	END02	O4		MSC0 output
	EN00	O5		MSC0 output
	SDA0	O6		I2C0 output
	CC61	O7		CCU60 output

Package and Pinning Definitions TC297x Pin Definition and Functions:

Table 2-61 Port 15 Functions (cont'd)

Pin	Symbol	Ctrl	Type	Function
A16	P15.6	I	MP / PU1 / VEXT	General-purpose input
	TIN77			GTM input
	MTSR2B			QSPI2 input
	P15.6			O0
	TOUT77	O1		GTM output
	ATX3	O2		ASCLIN3 output
	MTSR2	O3		QSPI2 output
	SLSO53	O4		QSPI5 output
	SCLK2	O5		QSPI2 output
	ASCLK3	O6		ASCLIN3 output
	CC60	O7		CCU60 output
D15	P15.7	I	MP / PU1 / VEXT	General-purpose input
	TIN78			GTM input
	ARX3A			ASCLIN3 input
	MRST2B			QSPI2 input
	P15.7	O0		General-purpose output
	TOUT78	O1		GTM output
	ATX3	O2		ASCLIN3 output
	MRST2	O3		QSPI2 output
	—	O4		Reserved
	—	O5		Reserved
	—	O6		Reserved
COU60	O7	CCU60 output		
D14	P15.8	I	MP / PU1 / VEXT	General-purpose input
	TIN79			GTM input
	SCLK2B			QSPI2 input
	REQ1			SCU input
	P15.8	O0		General-purpose output
	TOUT79	O1		GTM output
	—	O2		Reserved
	SCLK2	O3		QSPI2 output
	—	O4		Reserved
	—	O5		Reserved
	ASCLK3	O6		ASCLIN3 output
COU61	O7	CCU60 output		

Package and Pinning Definitions TC297x Pin Definition and Functions:

Table 2-62 Port 20 Functions

Pin	Symbol	Ctrl	Type	Function
H20	P20.0	I	MP / PU1 / VEXT	General-purpose input
	TIN59			GTM input
	RXDCAN3C			CAN node 3 input
	RXDCANr1C			CAN node 1 input (MultiCANr+)
	T6EUDA			GPT120 input
	REQ9			SCU input
	SYSCLK			HSCT input
	TGI0			OCDS input
	P20.0			O0
	TOUT59	O1		GTM output
	ATX3	O2		ASCLIN3 output
	ASCLK3	O3		ASCLIN3 output
	–	O4		Reserved
	SYSCLK	O5		HSCT output
	–	O6		Reserved
	–	O7		Reserved
	TGO0	HWOUT		OCDS; ENx
G19	P20.1	I	LP / PU1 / VEXT	General-purpose input
	TIN60			GTM input
	TGI1			OCDS input
	P20.1	O0		General-purpose output
	TOUT60	O1		GTM output
	–	O2		Reserved
	–	O3		Reserved
	–	O4		Reserved
	–	O5		Reserved
	–	O6		Reserved
	–	O7		Reserved
	TGO1	HWOUT		OCDS; ENx

Package and Pinning Definitions TC297x Pin Definition and Functions:

Table 2-62 Port 20 Functions (cont'd)

Pin	Symbol	Ctrl	Type	Function
H19	P20.2	I	LP / PU1 / VEXT	General-purpose input This pin is latched at power on reset release to enter test mode.
	$\overline{\text{TESTMODE}}$			OCDS input
	P20.2	O0		Output function not available
	–	O1		Output function not available
	–	O2		Output function not available
	–	O3		Output function not available
	–	O4		Output function not available
	–	O5		Output function not available
	–	O6		Output function not available
	–	O7		Output function not available
G20	P20.3	I	LP / PU1 / VEXT	General-purpose input
	TIN61			GTM input
	T6INA			GPT120 input
	ARX3C			ASCLIN3 input
	P20.3	O0		General-purpose output
	TOUT61	O1		GTM output
	ATX3	O2		ASCLIN3 output
	SLSO09	O3		QSPI0 output
	SLSO29	O4		QSPI2 output
	TXDCAN3	O5		CAN node 3 output
	TXDCANr1	O6		CAN node 1 output (MultiCANr+)
	–	O7		Reserved
F17	P20.6	I	LP / PU1 / VEXT	General-purpose input
	TIN62			GTM input
	P20.6	O0		General-purpose output
	TOUT62	O1		GTM output
	ARTS1	O2		ASCLIN1 output
	SLSO08	O3		QSPI0 output
	SLSO28	O4		QSPI2 output
	–	O5		Reserved
	WDT2LCK	O6		SCU output
	–	O7		Reserved

Package and Pinning Definitions TC297x Pin Definition and Functions:

Table 2-62 Port 20 Functions (cont'd)

Pin	Symbol	Ctrl	Type	Function
F19	P20.7	I	LP / PU1 / VEXT	General-purpose input
	TIN63			GTM input
	ACTS1A			ASCLIN1 input
	RXDCAN0B			CAN node 0 input
	P20.7	O0		General-purpose output
	TOUT63	O1		GTM output
	–	O2		Reserved
	–	O3		Reserved
	–	O4		Reserved
	–	O5		Reserved
	WDT1LCK	O6		SCU output
COUT63	O7	CCU61 output		
F20	P20.8	I	MP / PU1 / VEXT	General-purpose input
	TIN64			GTM input
	P20.8	O0		General-purpose output
	TOUT64	O1		GTM output
	ASLSO1	O2		ASCLIN1 output
	SLSO00	O3		QSPI0 output
	SLSO10	O4		QSPI1 output
	TXDCAN0	O5		CAN node 0 output
	WDT0LCK	O6		SCU output
	CC60	O7		CCU61 output
E17	P20.9	I	LP / PU1 / VEXT	General-purpose input
	TIN65			GTM input
	ARX1C			ASCLIN1 input
	RXDCAN3E			CAN node 3 input
	REQ11			SCU input
	SLSI0B			QSPI0 input
	P20.9			O0
	TOUT65	O1		GTM output
	–	O2		Reserved
	SLSO01	O3		QSPI0 output
	SLSO11	O4		QSPI1 output
	–	O5		Reserved
	WDTSLCK	O6		SCU output
	CC61	O7		CCU61 output

Package and Pinning Definitions TC297x Pin Definition and Functions:

Table 2-62 Port 20 Functions (cont'd)

Pin	Symbol	Ctrl	Type	Function
E19	P20.10	I	MP / PU1 / VEXT	General-purpose input
	TIN66			GTM input
	P20.10			General-purpose output
	TOUT66	O1		GTM output
	ATX1	O2		ASCLIN1 output
	SLSO06	O3		QSPI0 output
	SLSO27	O4		QSPI2 output
	TXDCAN3	O5		CAN node 3 output
	ASCLK1	O6		ASCLIN1 output
	CC62	O7		CCU61 output
E20	P20.11	I	MP / PU1 / VEXT	General-purpose input
	TIN67			GTM input
	SCLK0A			QSPI0 input
	P20.11	O0		General-purpose output
	TOUT67	O1		GTM output
	–	O2		Reserved
	SCLK0	O3		QSPI0 output
	–	O4		Reserved
	–	O5		Reserved
	–	O6		Reserved
	COUT60	O7		CCU61 output
D19	P20.12	I	MP / PU1 / VEXT	General-purpose input
	TIN68			GTM input
	MRST0A			QSPI0 input
	P20.12	O0		General-purpose output
	TOUT68	O1		GTM output
	–	O2		Reserved
	MRST0	O3		QSPI0 output
	MTSR0	O4		QSPI0 output
	–	O5		Reserved
	–	O6		Reserved
	COUT61	O7		CCU61 output

Package and Pinning Definitions TC297x Pin Definition and Functions:

Table 2-62 Port 20 Functions (cont'd)

Pin	Symbol	Ctrl	Type	Function
D20	P20.13	I	MP / PU1 / VEXT	General-purpose input
	TIN69			GTM input
	SLSI0A			QSPI0 input
	P20.13	O0		General-purpose output
	TOUT69	O1		GTM output
	–	O2		Reserved
	SLSO02	O3		QSPI0 output
	SLSO12	O4		QSPI1 output
	SCLK0	O5		QSPI0 output
	–	O6		Reserved
	COOUT62	O7		CCU61 output
C20	P20.14	I	MP / PU1 / VEXT	General-purpose input
	TIN70			GTM input
	MTSR0A			QSPI0 input
	P20.14	O0		General-purpose output
	TOUT70	O1		GTM output
	–	O2		Reserved
	MTSR0	O3		QSPI0 output
	–	O4		Reserved
	–	O5		Reserved
	–	O6		Reserved
	–	O7		Reserved

Table 2-63 Port 21 Functions

Pin	Symbol	Ctrl	Type	Function
K17	P21.0	I	LVDSH_N/ PU1 / VDDP3	General-purpose input
	TIN51			GTM input
	MRST4DN			QSPI4 input (LVDS)
	HOLD			EBU input
	P21.0	O0		General-purpose output
	TOUT51	O1		GTM output
	–	O2		Reserved
	–	O3		Reserved
	–	O4		Reserved
	–	O5		Reserved
	ETHMDC	O6		ETH output
	BAABA0	O7		EBU output (combined for BAA and BA0)
	HSM1	O		HSM output

Package and Pinning Definitions TC297x Pin Definition and Functions:

Table 2-63 Port 21 Functions (cont'd)

Pin	Symbol	Ctrl	Type	Function
J17	P21.1	I	LVDSH_P/ PU1 / VDDP3	General-purpose input
	TIN52			GTM input
	ETHMDIOB			ETH input (Not for production purposes)
	MRST4DP			QSPI4 input (LVDS)
	WAIT			EBU input
	P21.1	O0		General-purpose output
	TOUT52	O1		GTM output
	–	O2		Reserved
	–	O3		Reserved
	–	O4		Reserved
	–	O5		Reserved
	ETHMDIO	O6		ETH output (Not for production purposes)
	BREQBA1	O7		EBU output (combined for BREQ and BA1)
	HSM2	O		HSM output
K19	P21.2	I	LVDSH_N/ PU1 / VDDP3	General-purpose input
	TIN53			GTM input
	MRST2CN			QSPI2 input (LVDS)
	MRST4CN			QSPI4 input (LVDS)
	ARX3GN			ASCLIN3 input (LVDS)
	EMGSTOPB			SCU input
	RXDN			H SCT input (LVDS)
	P21.2	O0		General-purpose output
	TOUT53	O1		GTM output
	ASLSO3	O2		ASCLIN3 output
	–	O3		Reserved
	–	O4		Reserved
	ETHMDC	O5		ETH output
	SDRAMA8	O6		EBU output
	–	O7		Reserved

Package and Pinning Definitions TC297x Pin Definition and Functions:
Table 2-63 Port 21 Functions (cont'd)

Pin	Symbol	Ctrl	Type	Function
J19	P21.3	I	LVDSH_P/ PU1 / VDDP3	General-purpose input
	TIN54			GTM input
	MRST2CP			QSPI2 input (LVDS)
	MRST4CP			QSPI4 input (LVDS)
	ARX3GP			ASCLIN3 input (LVDS)
	RXDP			HSCT input (LVDS)
	P21.3			O0
	TOUT54	O1		GTM output
	–	O2		Reserved
	–	O3		Reserved
	–	O4		Reserved
	–	O5		Reserved
	SDRAMA9	O6		EBU output
	–	O7		Reserved
ETHMDIOD	HWOUT	ETH input/output		
K20	P21.4	I	LVDSH_N/ PU1 / VDDP3	General-purpose input
	TIN55			GTM input
	P21.4	O0		General-purpose output
	TOUT55	O1		GTM output
	–	O2		Reserved
	–	O3		Reserved
	–	O4		Reserved
	–	O5		Reserved
	SDRAMA10	O6		EBU output
	–	O7		Reserved
	TXDN	HSCT		HSCT output (LVDS)
J20	P21.5	I	LVDSH_P/ PU1 / VDDP3	General-purpose input
	TIN56			GTM input
	P21.5	O0		General-purpose output
	TOUT56	O1		GTM output
	ASCLK3	O2		ASCLIN3 output
	–	O3		Reserved
	–	O4		Reserved
	–	O5		Reserved
	SDRAMA11	O6		EBU output
	–	O7		Reserved
	TXDP	HSCT		HSCT output (LVDS)

Package and Pinning Definitions TC297x Pin Definition and Functions:
Table 2-63 Port 21 Functions (cont'd)

Pin	Symbol	Ctrl	Type	Function	
H17	P21.6	I	A2 / PU / VDDP3	General-purpose input	
	TIN57			GTM input	
	ARX3F			ASCLIN3 input	
	TGI2			OCDS input	
	TDI			OCDS (JTAG) input	
	T5EUDA			GPT120 input	
	P21.6			O0	General-purpose output
	TOUT57			O1	GTM output
	ASLSO3			O2	ASCLIN3 output
	–			O3	Reserved
	–			O4	Reserved
	SYSCLK			O5	H SCT output
	SDRAMA12			O6	EBU output
	T3OUT	O7		GPT120 output	
TGO2	HWOUT	OCDS; ENx			
H16	P21.7	I	A2 / PU / VDDP3	General-purpose input	
	TIN58			GTM input	
	DAP2			OCDS (3-Pin DAP) input In the 3-Pin DAP mode this pin is used as DAP2. In the 2-PIN DAP mode this pin is used as P21.7 and controlled by the related port control logic	
	TGI3			OCDS input	
	ETHRXERB			ETH input	
	T5INA			GPT120 input	
	P21.7			O0	General-purpose output
	TOUT58			O1	GTM output
	ATX3			O2	ASCLIN3 output
	ASCLK3			O3	ASCLIN3 output
	–			O4	Reserved
	–			O5	Reserved
	SDRAMA13			O6	EBU output
	T6OUT			O7	GPT120 output
	TGO3			HWOUT	OCDS; ENx
	TDO				OCDS (JTAG); ENx The JTAG TDO function is overlaid with P21.7 via a double bond. In JTAG mode this pin is used as TDO, after power-on reset it is HighZ.
	DAP2			OCDS (3-Pin DAP); ENx In the 3-Pin DAP mode this pin is used as DAP2.	

Package and Pinning Definitions TC297x Pin Definition and Functions:
Table 2-64 Port 22 Functions

Pin	Symbol	Ctrl	Type	Function
P20	P22.0	I	LVDSM_N / PU1 / VEXT	General-purpose input
	TIN47			GTM input
	MTSR4B			QSPI4 input
	P22.0	O0		General-purpose output
	TOUT47	O1		GTM output
	ATX3N	O2		ASCLIN3 output (LVDS)
	MTSR4	O3		QSPI4 output
	SCLK4N	O4		QSPI4 output (LVDS)
	FCLN1	O5		MSC1 output (LVDS)
	FCLND1	O6		MSC1 output (LVDS)
	–	O7		Reserved
P19	P22.1	I	LVDSM_P / PU1 / VEXT	General-purpose input
	TIN48			GTM input
	MRST4B			QSPI4 input
	P22.1	O0		General-purpose output
	TOUT48	O1		GTM output
	ATX3P	O2		ASCLIN3 output (LVDS)
	MRST4	O3		QSPI4 output
	SCLK4P	O4		QSPI4 output (LVDS)
	FCLP1	O5		MSC1 output (LVDS)
	–	O6		Reserved
	–	O7		Reserved
R20	P22.2	I	LVDSM_N / PU1 / VEXT	General-purpose input
	TIN49			GTM input
	SLSI4B			QSPI4 input
	P22.2	O0		General-purpose output
	TOUT49	O1		GTM output
	–	O2		Reserved
	SLSO43	O3		QSPI4 output
	MTSR4N	O4		QSPI4 output (LVDS)
	SON1	O5		MSC1 output (LVDS)
	SOND1	O6		MSC1 output (LVDS)
	–	O7		Reserved

Package and Pinning Definitions TC297x Pin Definition and Functions:
Table 2-64 Port 22 Functions (cont'd)

Pin	Symbol	Ctrl	Type	Function	
R19	P22.3	I	LVDSM_P / PU1 / VEXT	General-purpose input	
	TIN50			GTM input	
	SCLK4B			QSPI4 input	
	P22.3			O0	General-purpose output
	TOUT50	O1		GTM output	
	–	O2		Reserved	
	SCLK4	O3		QSPI4 output	
	MTSR4P	O4		QSPI4 output (LVDS)	
	SOP1	O5		MSC1 output (LVDS)	
	–	O6		Reserved	
	–	O7		Reserved	
P16	P22.4	I	LP / PU1 / VEXT	General-purpose input	
	TIN130			GTM input	
	P22.4			O0	General-purpose output
	TOUT130			O1	GTM output
	–	O2		Reserved	
	–	O3		Reserved	
	SLSO012	O4		QSPI0 output	
	PSITX4	O5		PSI5 output	
	–	O6		Reserved	
	–	O7		Reserved	
	P17	P22.5		I	LP / PU1 / VEXT
TIN131		GTM input			
MTSR0C		QSPI0 input			
PSIRX4B		PSI5 input			
P22.5		O0	General-purpose output		
TOUT131		O1	GTM output		
–		O2	Reserved		
–		O3	Reserved		
MTSR0		O4	QSPI0 output		
–		O5	Reserved		
–		O6	Reserved		
–		O7	Reserved		

Package and Pinning Definitions TC297x Pin Definition and Functions:

Table 2-64 Port 22 Functions (cont'd)

Pin	Symbol	Ctrl	Type	Function
N16	P22.6	I	LP / PU1 / VEXT	General-purpose input
	TIN132			GTM input
	MRST0C			QSPIO input
	P22.6	O0		General-purpose output
	TOUT132	O1		GTM output
	—	O2		Reserved
	—	O3		Reserved
	MRST0	O4		QSPIO output
	—	O5		Reserved
	—	O6		Reserved
—	O7	Reserved		
N17	P22.7	I	LP / PU1 / VEXT	General-purpose input
	TIN133			GTM input
	SCLK0C			QSPIO input
	P22.7	O0		General-purpose output
	TOUT133	O1		GTM output
	—	O2		Reserved
	—	O3		Reserved
	SCLK0	O4		QSPIO output
	—	O5		Reserved
	—	O6		Reserved
—	O7	Reserved		
M16	P22.8	I	LP / PU1 / VEXT	General-purpose input
	TIN134			GTM input
	SCLK0B			QSPIO input
	P22.8	O0		General-purpose output
	TOUT134	O1		GTM output
	—	O2		Reserved
	—	O3		Reserved
	SCLK0	O4		QSPIO output
	—	O5		Reserved
	—	O6		Reserved
—	O7	Reserved		

Package and Pinning Definitions TC297x Pin Definition and Functions:

Table 2-64 Port 22 Functions (cont'd)

Pin	Symbol	Ctrl	Type	Function
M17	P22.9	I	LP / PU1 / VEXT	General-purpose input
	TIN135			GTM input
	MRST0B			QSPIO input
	P22.9	O0		General-purpose output
	TOUT135	O1		GTM output
	—	O2		Reserved
	—	O3		Reserved
	MRST0	O4		QSPIO output
	—	O5		Reserved
	—	O6		Reserved
—	O7	Reserved		
L16	P22.10	I	LP / PU1 / VEXT	General-purpose input
	TIN136			GTM input
	MTSR0B			QSPIO input
	P22.10	O0		General-purpose output
	TOUT136	O1		GTM output
	—	O2		Reserved
	—	O3		Reserved
	MTSR0	O4		QSPIO output
	—	O5		Reserved
	—	O6		Reserved
—	O7	Reserved		
L17	P22.11	I	LP / PU1 / VEXT	General-purpose input
	TIN137			GTM input
	P22.11			O0
	TOUT137	O1		GTM output
	—	O2		Reserved
	—	O3		Reserved
	SLSO010	O4		QSPIO output
	—	O5		Reserved
	—	O6		Reserved
	—	O7		Reserved

Package and Pinning Definitions TC297x Pin Definition and Functions:

Table 2-65 Port 23 Functions

Pin	Symbol	Ctrl	Type	Function
V20	P23.0	I	LP / PU1 / VEXT	General-purpose input
	TIN41			GTM input
	P23.0	O0		General-purpose output
	TOUT41	O1		GTM output
	—	O2		Reserved
	—	O3		Reserved
	—	O4		Reserved
	—	O5		Reserved
	—	O6		Reserved
	—	O7		Reserved
U19	P23.1	I	MP+ / PU1 / VEXT	General-purpose input
	TIN42			GTM input
	SDI10			MSC1 input
	P23.1	O0		General-purpose output
	TOUT42	O1		GTM output
	ARTS1	O2		ASCLIN1 output
	SLSO46	O3		QSPI4 output
	GTMCLK0	O4		GTM output
	—	O5		Reserved
	EXTCLK0	O6		SCU output
—	O7	Reserved		
U20	P23.2	I	LP / PU1 / VEXT	General-purpose input
	TIN43			GTM input
	P23.2	O0		General-purpose output
	TOUT43	O1		GTM output
	—	O2		Reserved
	—	O3		Reserved
	—	O4		Reserved
	—	O5		Reserved
	—	O6		Reserved
	—	O7		Reserved

Package and Pinning Definitions TC297x Pin Definition and Functions:

Table 2-65 Port 23 Functions (cont'd)

Pin	Symbol	Ctrl	Type	Function
T19	P23.3	I	LP / PU1 / VEXT	General-purpose input
	TIN44			GTM input
	INJ10			MSC1 input
	P23.3	O0		General-purpose output
	TOUT44	O1		GTM output
	—	O2		Reserved
	—	O3		Reserved
	—	O4		Reserved
	—	O5		Reserved
	—	O6		Reserved
—	O7	Reserved		
T20	P23.4	I	MP+ / PU1 / VEXT	General-purpose input
	TIN45			GTM input
	P23.4			O0
	TOUT45	O1		GTM output
	—	O2		Reserved
	SLSO45	O3		QSPI4 output
	END12	O4		MSC1 output
	EN10	O5		MSC1 output
	—	O6		Reserved
	—	O7		Reserved
T17	P23.5	I	MP+ / PU1 / VEXT	General-purpose input
	TIN46			GTM input
	P23.5			O0
	TOUT46	O1		GTM output
	—	O2		Reserved
	SLSO44	O3		QSPI4 output
	END13	O4		MSC1 output
	EN11	O5		MSC1 output
	—	O6		Reserved
	—	O7		Reserved

Package and Pinning Definitions TC297x Pin Definition and Functions:
Table 2-65 Port 23 Functions (cont'd)

Pin	Symbol	Ctrl	Type	Function
R17	P23.6	I	LP / PU1 / VEXT	General-purpose input
	TIN138			GTM input
	P23.6	O0		General-purpose output
	TOUT138	O1		GTM output
	—	O2		Reserved
	—	O3		Reserved
	SLSO011	O4		QSPI0 output
	—	O5		Reserved
	—	O6		Reserved
	—	O7		Reserved
R16	P23.7	I	LP / PU1 / VEXT	General-purpose input
	TIN139			GTM input
	P23.7	O0		General-purpose output
	TOUT139	O1		GTM output
	—	O2		Reserved
	—	O3		Reserved
	—	O4		Reserved
	—	O5		Reserved
	—	O6		Reserved
	—	O7		Reserved

Table 2-66 Port 32 Functions

Pin	Symbol	Ctrl	Type	Function
Y17	P32.0	I	LP / PX/ VEXT	General-purpose input
	TIN36			GTM input
	FDEST			PMU input
	VGATE1N			SMPS mode: analog output. External Pass Device gate control for EVR13
	P32.0	O0		General-purpose output
	TOUT36	O1		GTM output
	—	O2		Reserved
	—	O3		Reserved
	—	O4		Reserved
	—	O5		Reserved
	—	O6		Reserved
	—	O7		Reserved

Package and Pinning Definitions TC297x Pin Definition and Functions:
Table 2-66 Port 32 Functions (cont'd)

Pin	Symbol	Ctrl	Type	Function
Y18	P32.2	I	LP / PU1 / VEXT	General-purpose input
	TIN38			GTM input
	ARX3D			ASCLIN3 input
	RXDCAN3B			CAN node 3 input
	RXDCANr1D			CAN node 1 input (MultiCANr+)
	P32.2	O0		General-purpose output
	TOUT38	O1		GTM output
	ATX3	O2		ASCLIN3 output
	-	O3		Reserved
	-	O4		Reserved
	-	O5		Reserved
	DCDCSYNC	O6		SCU output
	-	O7		Reserved
Y19	P32.3	I	LP / PU1 / VEXT	General-purpose input
	TIN39			GTM input
	P32.3	O0		General-purpose output
	TOUT39	O1		GTM output
	ATX3	O2		ASCLIN3 output
	-	O3		Reserved
	ASCLK3	O4		ASCLIN3 output
	TXDCAN3	O5		CAN node 3 output
	TXDCANr1	O6		CAN node 1 output (MultiCANr+)
	-	O7		Reserved
W18	P32.4	I	MP+ / PU1 / VEXT	General-purpose input
	TIN40			GTM input
	ACTS1B			ASCLIN1 input
	SDI12			MSC1 input
	P32.4	O0		General-purpose output
	TOUT40	O1		GTM output
	-	O2		Reserved
	END12	O3		MSC1 output
	GTMCLK1	O4		GTM output
	EN10	O5		MSC1 output
	EXTCLK1	O6		SCU output
	COU63	O7		CCU60 output

Package and Pinning Definitions TC297x Pin Definition and Functions:

Table 2-66 Port 32 Functions (cont'd)

Pin	Symbol	Ctrl	Type	Function
T15	P32.5	I	LP / PU1 / VEXT	General-purpose input
	TIN140			GTM input
	P32.5	O0		General-purpose output
	TOUT140	O1		GTM output
	ATX2	O2		ASCLIN2 output
	—	O3		Reserved
	—	O4		Reserved
	—	O5		Reserved
	TXDCAN2	O6		CAN node 2 output
	—	O7		Reserved
U15	P32.6	I	LP / PU1 / VEXT	General-purpose input
	TGI4			OCDS input
	TIN141			GTM input
	RXDCAN2C			CAN node 2 input
	ARX2F			ASCLIN2 input
	P32.6	O0		General-purpose output
	TOUT141	O1		GTM output
	—	O2		Reserved
	—	O3		Reserved
	SLSO212	O4		QSPI2 output
	—	O5		Reserved
	—	O6		Reserved
	—	O7		Reserved
	TGO4	HWOUT		OCDS; ENx
U16	P32.7	I	LP / PU1 / VEXT	General-purpose input
	TIN142			GTM input
	TGI5			OCDS input
	P32.7	O0		General-purpose output
	TOUT142	O1		GTM output
	—	O2		Reserved
	—	O3		Reserved
	—	O4		Reserved
	—	O5		Reserved
	—	O6		Reserved
	—	O7		Reserved
	TGO5	HWOUT		OCDS; ENx

Package and Pinning Definitions TC297x Pin Definition and Functions:

Table 2-67 Port 33 Functions

Pin	Symbol	Ctrl	Type	Function
W10	P33.0	I	LP / PU1 / VEXT	General-purpose input
	TIN22			GTM input
	DSITR0E			DSADC channel 0 input E
	P33.0	O0		General-purpose output
	TOUT22	O1		GTM output
	–	O2		Reserved
	–	O3		Reserved
	–	O4		Reserved
	–	O5		Reserved
	VADCG2BFL0	O6		VADC output
	–	O7		Reserved
Y10	P33.1	I	LP / PU1 / VEXT	General-purpose input
	TIN23			GTM input
	PSIRX0C			PSI5 input
	SENT9C			SENT input
	DSCIN2B			DSADC channel 2 input B
	DSITR1E			DSADC channel 1 input E
	P33.1	O0		General-purpose output
	TOUT23	O1		GTM output
	ASLSO3	O2		ASCLIN3 output
	SCLK2	O3		QSPI2 output
	DSCOUT2	O4		DSADC channel 2 output
	VADCEMUX02	O5		VADC output
	VADCG2BFL1	O6		VADC output
	–	O7		Reserved
W11	P33.2	I	LP / PU1 / VEXT	General-purpose input
	TIN24			GTM input
	SENT8C			SENT input
	DSDIN2B			DSADC channel 2 input B
	DSITR2E			DSADC channel 2 input E
	P33.2	O0		General-purpose output
	TOUT24	O1		GTM output
	ASCLK3	O2		ASCLIN3 output
	SLSO210	O3		QSPI2 output
	PSITX0	O4		PSI5 output
	VADCEMUX01	O5		VADC output
	VADCG2BFL2	O6		VADC output
	–	O7		Reserved

Package and Pinning Definitions TC297x Pin Definition and Functions:

Table 2-67 Port 33 Functions (cont'd)

Pin	Symbol	Ctrl	Type	Function
Y11	P33.3	I	LP / PU1 / VEXT	General-purpose input
	TIN25			GTM input
	PSIRX1C			PSI5 input
	SENT7C			SENT input
	DSCIN1B			DSADC channel 1 input B
	P33.3			O0
	TOUT25	O1		GTM output
	–	O2		Reserved
	–	O3		Reserved
	DSCOUT1	O4		DSADC channel 1 output
	VADCEMUX00	O5		VADC output
	VADCG2BFL3	O6		VADC output
	–	O7		Reserved
	W12	P33.4		I
TIN26		GTM input		
SENT6C		SENT input		
CTRAPC		CCU61 input		
DSDIN1B		DSADC channel 1 input		
DSITR0F		DSADC channel 0 input F		
P33.4		O0	General-purpose output	
TOUT26		O1	GTM output	
ARTS2		O2	ASCLIN2 output	
SLSO212		O3	QSPI2 output	
PSITX1		O4	PSI5 output	
VADCEMUX12		O5	VADC output	
VADCG0BFL0		O6	VADC output	
–		O7	Reserved	

Package and Pinning Definitions TC297x Pin Definition and Functions:

Table 2-67 Port 33 Functions (cont'd)

Pin	Symbol	Ctrl	Type	Function
Y12	P33.5	I	LP / PU1 / VEXT	General-purpose input
	TIN27			GTM input
	ACTS2B			ASCLIN2 input
	PSIRX2C			PSI5 input
	PSISRXC			PSI5-S input
	SENT5C			SENT input
	CCPOS2C			CCU61 input
	T4EADB			GPT120 input
	DSCIN0B			DSADC channel 0 input B
	DSITR1F			DSADC channel 1 input F
	P33.5			O0
	TOUT27	O1	GTM output	
	SLSO07	O2	QSPI0 output	
	SLSO17	O3	QSPI1 output	
	DSCOUT0	O4	DSADC channel 0 output	
	VADCEMUX11	O5	VADC output	
	VADCG0BFL1	O6	VADC output	
	-	O7	Reserved	
	W13	P33.6	I	LP / PU1 / VEXT
TIN28		GTM input		
SENT4C		SENT input		
CCPOS1C		CCU61 input		
T2EADB		GPT120 input		
DSDIN0B		DSADC channel 0 input B		
DSITR2F		DSADC channel 2 input F		
P33.6		O0	General-purpose output	
TOUT28		O1	GTM output	
ASLSO2		O2	ASCLIN2 output	
SLSO211		O3	QSPI2 output	
PSITX2		O4	PSI5 output	
VADCEMUX10		O5	VADC output	
VADCG1BFL0		O6	VADC output	
PSISTX		O7	PSI5-S output	

Package and Pinning Definitions TC297x Pin Definition and Functions:

Table 2-67 Port 33 Functions (cont'd)

Pin	Symbol	Ctrl	Type	Function
Y13	P33.7	I	LP / PU1 / VEXT	General-purpose input
	TIN29			GTM input
	RXDCAN0E			CAN node 0 input
	REQ8			SCU input
	CCPOS0C			CCU61 input
	T2INB			GPT120 input
	P33.7			O0
	TOUT29	O1		GTM output
	ASCLK2	O2		ASCLIN2 output
	SLSO47	O3		QSPI4 output
	–	O4		Reserved
	–	O5		Reserved
	VADCG1BFL1	O6		VADC output
	–	O7		Reserved
W14	P33.8	I	MP / HighZ / VEXT	General-purpose input
	TIN30			GTM input
	ARX2E			ASCLIN2 input
	EMGSTOPA			SCU input
	P33.8	O0		General-purpose output
	TOUT30	O1		GTM output
	ATX2	O2		ASCLIN2 output
	SLSO42	O3		QSPI4 output
	–	O4		Reserved
	TXDCAN0	O5		CAN node 0 output
	–	O6		Reserved
	COUT62	O7		CCU61 output
	SMUFSP	HWOUT		SMU
Y14	P33.9	I	LP / PU1 / VEXT	General-purpose input
	TIN31			GTM input
	HSIC3INA			QSPI3 input
	P33.9	O0		General-purpose output
	TOUT31	O1		GTM output
	ATX2	O2		ASCLIN2 output
	SLSO41	O3		QSPI4 output
	ASCLK2	O4		ASCLIN2 output
	–	O5		Reserved
	–	O6		Reserved
	CC62	O7		CCU61 output

Package and Pinning Definitions TC297x Pin Definition and Functions:

Table 2-67 Port 33 Functions (cont'd)

Pin	Symbol	Ctrl	Type	Function
W15	P33.10	I	MP / PU1 / VEXT	General-purpose input
	TIN32			GTM input
	SLSI4A			QSPI4 input
	HSIC3INB			QSPI3 input
	P33.10	O0		General-purpose output
	TOUT32	O1		GTM output
	SLSO16	O2		QSPI1 output
	SLSO40	O3		QSPI4 output
	ASLSO1	O4		ASCLIN1 output
	PSISCLK	O5		PSI5-S output
	–	O6		Reserved
COUT61	O7	CCU61 output		
Y15	P33.11	I	MP / PU1 / VEXT	General-purpose input
	TIN33			GTM input
	SCLK4A			QSPI4 input
	P33.11			O0
	TOUT33	O1		GTM output
	ASCLK1	O2		ASCLIN1 output
	SCLK4	O3		QSPI4 output
	–	O4		Reserved
	–	O5		Reserved
	DSCGPWMN	O6		DSADC channel output
	CC61	O7		CCU61 output
W16	P33.12	I	MP / PU1 / VEXT	General-purpose input
	TIN34			GTM input
	MTSR4A			QSPI4 input
	P33.12			O0
	TOUT34	O1		GTM output
	ATX1	O2		ASCLIN1 output
	MTSR4	O3		QSPI4 output
	ASCLK1	O4		ASCLIN1 output
	–	O5		Reserved
	DSCGPWMP	O6		DSADC output
	COUT60	O7		CCU61 output

Package and Pinning Definitions TC297x Pin Definition and Functions:

Table 2-67 Port 33 Functions (cont'd)

Pin	Symbol	Ctrl	Type	Function
Y16	P33.13	I	MP / PU1 / VEXT	General-purpose input
	TIN35			GTM input
	ARX1F			ASCLIN1 input
	MRST4A			QSPI4 input
	DSSGNB			DSADC channel input B
	INJ11			MSC1 input
	P33.13			O0
	TOUT35	O1		GTM output
	ATX1	O2		ASCLIN1 output
	MRST4	O3		QSPI4 output
	SLSO26	O4		QSPI2 output
	–	O5		Reserved
	DCDCSYNC	O6		SCU output
	CC60	O7		CCU61 output
T14	P33.14	I	LP / PU1 / VEXT	General-purpose input
	TIN143			GTM input
	$\overline{\text{TGI6}}$			OCDS input
	SCLK2D			QSPI2 input
	P33.14			O0
	TOUT143	O1		GTM output
	–	O2		Reserved
	SCLK2	O3		QSPI2 output
	–	O4		Reserved
	–	O5		Reserved
	–	O6		Reserved
	CC62	O7		CCU60 output
	$\overline{\text{TGO6}}$	HWOUT		OCDS; ENx
		T		

Package and Pinning Definitions TC297x Pin Definition and Functions:

Table 2-67 Port 33 Functions (cont'd)

Pin	Symbol	Ctrl	Type	Function
U14	P33.15	I	LP / PU1 / VEXT	General-purpose input
	TIN144			GTM input
	TGI7			OCDS input
	P33.15	O0		General-purpose output
	TOUT144	O1		GTM output
	—	O2		Reserved
	SLSO211	O3		QSPI2 output
	—	O4		Reserved
	—	O5		Reserved
	—	O6		Reserved
	COU62	O7		CCU60 output
	TGO7	HWOUT		OCDS; ENx

Table 2-68 Port 34 Functions

Pin	Symbol	Ctrl	Type	Function
U11	P34.1	I	LP / PU1 / VEXT	General-purpose input
	TIN146			GTM input
	P34.1	O0		General-purpose output
	TOUT146	O1		GTM output
	ATX0	O2		ASCLIN0 output
	—	O3		Reserved
	TXDCAN0	O4		CAN node 0 output
	TXDCANr0	O5		CAN node 0 output (MultiCANr+)
	—	O6		Reserved
	COU63	O7		CCU60 output
T12	P34.2	I	LP / PU1 / VEXT	General-purpose input
	TIN147			GTM input
	ARX0D			ASCLIN0 input
	RXDCAN0G			CAN node 0 input
	RXDCANr0C			CAN node 0 input (MultiCANr+)
	P34.2	O0		General-purpose output
	TOUT147	O1		GTM output
	—	O2		Reserved
	—	O3		Reserved
	—	O4		Reserved
	—	O5		Reserved
	—	O6		Reserved
	CC60	O7		CCU60 output

Package and Pinning Definitions TC297x Pin Definition and Functions:

Table 2-68 Port 34 Functions (cont'd)

Pin	Symbol	Ctrl	Type	Function
U12	P34.3	I	LP / PU1 / VEXT	General-purpose input
	TIN148			GTM input
	P34.3			General-purpose output
	TOUT148	O0		GTM output
	—	O1		Reserved
	—	O2		Reserved
	—	O3		Reserved
	SLSO210	O4		QSPI2 output
	—	O5		Reserved
	—	O6		Reserved
COUT60	O7	CCU60 output		
T13	P34.4	I	LP / PU1 / VEXT	General-purpose input
	TIN149			GTM input
	MRST2D			QSPI2 input
	P34.4	O0		General-purpose output
	TOUT149	O1		GTM output
	—	O2		Reserved
	—	O3		Reserved
	MRST2	O4		QSPI2 output
	—	O5		Reserved
	—	O6		Reserved
CC61	O7	CCU60 output		
U13	P34.5	I	LP / PU1 / VEXT	General-purpose input
	TIN150			GTM input
	MTRSR2D			QSPI2 input
	P34.5	O0		General-purpose output
	TOUT150	O1		GTM output
	—	O2		Reserved
	—	O3		Reserved
	MTRSR2	O4		QSPI2 output
	—	O5		Reserved
	—	O6		Reserved
COUT61	O7	CCU60 output		

Package and Pinning Definitions TC297x Pin Definition and Functions:
Table 2-69 Port 40 Functions

Pin	Symbol	Ctrl	Type	Function
W2	P40.0	I	S / HighZ / VDDM	General-purpose input
	VADCG3.0			VADC analog input channel 0 of group 3
	DS2PB			DSADC: positive analog input of channel 2, pin B
	CCPOS0D			CCU60 input
	SENT0A			SENT input
W1	P40.1	I	S / HighZ / VDDM	General-purpose input
	VADCG3.1			VADC analog input channel 1 of group 3 (with pull down diagnostics)
	DS2NB			DSADC: negative analog input channel 2, pin B
	CCPOS1B			CCU60 input
	SENT1A			SENT input
V2	P40.2	I	S / HighZ / VDDM	General-purpose input
	VADCG3.2			VADC analog input channel 2 of group 3 (with pull down diagnostics)
	CCPOS1D			CCU60 input
	SENT2A			SENT input
V1	P40.3	I	S / HighZ / VDDM	General-purpose input
	VADCG3.3			VADC analog input channel 3 of group 3 (with pull down diagnostics)
	CCPOS2B			CCU60 input
	SENT3A			SENT input
P4	P40.4	I	S / HighZ / VDDM	General-purpose input
	VADCG4.0			VADC analog input channel 0 of group 4
	CCPOS2D			CCU60 input
	SENT4A			SENT input
R1	P40.5	I	S / HighZ / VDDM	General-purpose input
	VADCG4.1			VADC analog input channel 1 of group 4
	CCPOS0D			CCU61 input
	SENT5A			SENT input
N4	P40.6	I	S / HighZ / VDDM	General-purpose input
	VADCG4.4			VADC analog input channel 4 of group 4
	DS3PA			DSADC: positive analog input of channel 3, pin A
	CCPOS1B			CCU61 input
	SENT6A			SENT input

Package and Pinning Definitions TC297x Pin Definition and Functions:
Table 2-69 Port 40 Functions (cont'd)

Pin	Symbol	Ctrl	Type	Function
P2	P40.7	I	S / HighZ / VDDM	General-purpose input
	VADCG4.5			VADC analog input channel 5 of group 4
	DS3NA			DSADC: negative analog input channel 3, pin A
	CCPOS1D			CCU61 input
	SENT7A			SENT input
N5	P40.8	I	S / HighZ / VDDM	General-purpose input
	VADCG4.6			VADC analog input channel 6 of group 4
	DS3PB			DSADC: positive analog input of channel 3, pin B
	CCPOS2B			CCU61 input
	SENT8A			SENT input
P1	P40.9	I	S / HighZ / VDDM	General-purpose input
	VADCG4.7			VADC analog input channel 7 of group 4
	DS3NB			DSADC: negative analog input channel 3, pin B
	CCPOS2D			CCU61 input
	SENT9A			SENT input

Table 2-70 Analog Inputs

Pin	Symbol	Ctrl	Type	Function
T10	AN0	I	D / HighZ / VDDM	Analog input 0
	VADCG0.0			VADC analog input channel 0 of group 0
	DS1PA			DSADC: positive analog input of channel 1, pin A
U10	AN1	I	D / HighZ / VDDM	Analog input 1
	VADCG0.1			VADC analog input channel 1 of group 0
	DS1NA			DSADC: negative analog input channel 1, pin A
W9	AN2	I	D / HighZ / VDDM	Analog input 2
	VADCG0.2			VADC analog input channel 2 of group 0
	DS0PA			DSADC: positive analog input of channel 0, pin A
U9	AN3	I	D / HighZ / VDDM	Analog input 3
	VADCG0.3			VADC analog input channel 3 of group 0
	DS0NA			DSADC: negative analog input channel 0, pin A
T9	AN4	I	D / HighZ / VDDM	Analog input 4
	VADCG0.4			VADC analog input channel 4 of group 0
Y9	AN5	I	D / HighZ / VDDM	Analog input 5
	VADCG0.5			VADC analog input channel 5 of group 0
T8	AN6	I	D / HighZ / VDDM	Analog input 6
	VADCG0.6			VADC analog input channel 6 of group 0
U8	AN7	I	D / HighZ / VDDM	Analog input 7
	VADCG0.7			VADC analog input channel 7 of group 0

Package and Pinning Definitions TC297x Pin Definition and Functions:
Table 2-70 Analog Inputs (cont'd)

Pin	Symbol	Ctrl	Type	Function
W8	AN8	I	D / HighZ / VDDM	Analog input 8
	VADCG1.0			VADC analog input channel 0 of group 1
U7	AN9	I	D / HighZ / VDDM	Analog input 9
	VADCG1.1			VADC analog input channel 1 of group 1
Y8	AN10	I	D / HighZ / VDDM	Analog input 10
	VADCG1.2			VADC analog input channel 2 of group 1
W7	AN11	I	D / HighZ / VDDM	Analog input 11
	VADCG1.3			VADC analog input channel 3 of group 1 (with pull down diagnostics)
T7	AN12	I	D / HighZ / VDDM	Analog input 12
	VADCG1.4			VADC analog input channel 4 of group 1
W6	AN13	I	D / HighZ / VDDM	Analog input 13
	VADCG1.5			VADC analog input channel 5 of group 1
U6	AN14	I	D / HighZ / VDDM	Analog input 14
	VADCG1.6			VADC analog input channel 6 of group 1
T6	AN15	I	D / HighZ / VDDM	Analog input 15
	VADCG1.7			VADC analog input channel 7 of group 1
W5	AN16	I	D / HighZ / VDDM	Analog input 16
	VADCG2.0			VADC analog input channel 0 of group 2
U5	AN17	I	D / HighZ / VDDM	Analog input 17
	VADCG2.1			VADC analog input channel 1 of group 2
W4	AN18	I	D / HighZ / VDDM	Analog input 18
	VADCG2.2			VADC analog input channel 2 of group 2
W3	AN19	I	D / HighZ / VDDM	Analog input 19
	VADCG2.3			VADC analog input channel 3 of group 2 (with pull down diagnostics)
Y3	AN20	I	D / HighZ / VDDM	Analog input 20
	VADCG2.4			VADC analog input channel 4 of group 2
	DS2PA			DSADC: positive analog input of channel 2, pin A
Y2	AN21	I	D / HighZ / VDDM	Analog input 21
	VADCG2.5			VADC analog input channel 5 of group 2
	DS2NA			DSADC: negative analog input channel 2, pin A
T5	AN22	I	D / HighZ / VDDM	Analog input 22
	VADCG2.6			VADC analog input channel 6 of group 2
R5	AN23	I	D / HighZ / VDDM	Analog input 23
	VADCG2.7			VADC analog input channel 7 of group 2

Package and Pinning Definitions TC297x Pin Definition and Functions:
Table 2-70 Analog Inputs (cont'd)

Pin	Symbol	Ctrl	Type	Function
W2	AN24	I	S / HighZ / VDDM	Analog input 24
	VADCG3.0			VADC analog input channel 0 of group 3
	DS2PB			DSADC: positive analog input of channel 2, pin B
	SENT0A			SENT input channel 0, pin A
W1	AN25	I	S / HighZ / VDDM	Analog input 24
	VADCG3.1			VADC analog input channel 1 of group 3 (with pull down diagnostics)
	DS2NB			DSADC: negative analog input channel 2, pin B
	SENT1A			SENT input channel 1, pin A
V2	AN26	I	S / HighZ / VDDM	Analog input 26
	VADCG3.2			VADC analog input channel 2 of group 3 (with pull down diagnostics)
	SENT2A			SENT input channel 2, pin A
V1	AN27	I	S / HighZ / VDDM	Analog input 27
	VADCG3.3			VADC analog input channel 3 of group 3 (with pull down diagnostics)
	SENT3A			SENT input channel 3, pin A
U2	AN28	I	D / HighZ / VDDM	Analog input 28
	VADCG3.4			VADC analog input channel 4 of group 3 (with pull down diagnostics)
U1	AN29	I	D / HighZ / VDDM	Analog input 29
	VADCG3.5			VADC analog input channel 5 of group 3 (with pull down diagnostics)
T4	AN30	I	D / HighZ / VDDM	Analog input 30
	VADCG3.6			VADC analog input channel 6 of group 3
R4	AN31	I	D / HighZ / VDDM	Analog input 31
	VADCG3.7			VADC analog input channel 7 of group 3
P4	AN32	I	S / HighZ / VDDM	Analog input 32
	VADCG4.0			VADC analog input channel 0 of group 4
	SENT4A			SENT input channel 4, pin A
R1	AN33	I	S / HighZ / VDDM	Analog input 33
	VADCG4.1			VADC analog input channel 1 of group 4
	SENT5A			SENT input channel 5, pin A
P5	AN34	I	D / HighZ / VDDM	Analog input 34
	VADCG4.2			VADC analog input channel 2 of group 4
R2	AN35	I	D / HighZ / VDDM	Analog input 35
	VADCG4.3			VADC analog input channel 3 of group 4 (with pull down diagnostics)

Package and Pinning Definitions TC297x Pin Definition and Functions:
Table 2-70 Analog Inputs (cont'd)

Pin	Symbol	Ctrl	Type	Function
N4	AN36	I	S / HighZ / VDDM	Analog input 34
	VADCG4.4			VADC analog input channel 4 of group 4
	DS3PA			DSADC: positive analog input of channel 3, pin A
	SENT6A			SENT input channel 6, pin A
P2	AN37	I	S / HighZ / VDDM	Analog input 37
	VADCG4.5			VADC analog input channel 5 of group 4
	DS3NA			DSADC: negative analog input channel 3, pin A
	SENT7A			SENT input channel 7, pin A
N5	AN38	I	S / HighZ / VDDM	Analog input 38
	VADCG4.6			VADC analog input channel 6 of group 4
	DS3PB			DSADC: positive analog input of channel 3, pin B
	SENT8A			SENT input channel 8, pin A
P1	AN39	I	S / HighZ / VDDM	Analog input 39
	VADCG4.7			VADC analog input channel 7 of group 4
	DS3NB			DSADC: negative analog input channel 3, pin B
	SENT9A			SENT input channel 9, pin A
M5	AN40	I	D / HighZ / VDDM	Analog input 40
	VADCG5.0			VADC analog input channel 0 of group 5
M4	AN41	I	D / HighZ / VDDM	Analog input 41
	VADCG5.1			VADC analog input channel 1 of group 5
L5	AN42	I	D / HighZ / VDDM	Analog input 42
	VADCG5.2			VADC analog input channel 2 of group 5
L4	AN43	I	D / HighZ / VDDM	Analog input 43
	VADCG5.3			VADC analog input channel 3 of group 5 (with pull down diagnostics)
N1	AN44	I	D / HighZ / VDDM	Analog input 44
	VADCG5.4			VADC analog input channel 4 of group 5
	DS3PC			DSADC: positive analog input of channel 3, pin C
N2	AN45	I	D / HighZ / VDDM	Analog input 45
	VADCG5.5			VADC analog input channel 5 of group 5
	DS3NC			DSADC: negative analog input channel 3, pin C
M1	AN46	I	D / HighZ / VDDM	Analog input 46
	VADCG5.6			VADC analog input channel 6 of group 5
	DS3PD			DSADC: positive analog input of channel 3, pin D
M2	AN47	I	D / HighZ / VDDM	Analog input 47
	VADCG5.7			VADC analog input channel 7 of group 5
	DS3ND			DSADC: negative analog input channel 3, pin D

Package and Pinning Definitions TC297x Pin Definition and Functions:
Table 2-71 System I/O

Pin	Symbol	Ctrl	Type	Function
G17	PORST	I	PORST / PD / VEXT	Power On Reset Input Additional strong PD in case of power fail.
F16	ESR0	I/O	MP / OD / VEXT	External System Request Reset 0 Default configuration during and after reset is open-drain driver. The driver drives low during power-on reset. This is valid additionally after deactivation of PORST until the internal reset phase has finished. See also SCU chapter for details. Default after power-on can be different. See also SCU chapter 'Reset Control Unit' and SCU_IOCRR register description.
	EVRWUP	I		EVR Wakeup Pin
G16	ESR1	I/O	MP / PU1 / VEXT	External System Request Reset 1 Default NMI function. See also SCU chapter 'Reset Control Unit' and SCU_IOCRR register description.
	EVRWUP	I		EVR Wakeup Pin
W17	VGATE1P	O	VGATE1P / - / VEXT	External Pass Device gate control for EVR13
K16	TMS	I	A2 / PD / VDDP3	JTAG Module State Machine Control Input
	DAP1	I/O		Device Access Port Line 1
L19	TRST	I	A2 / PD / VDDP3	JTAG Module Reset/Enable Input
J16	TCK	I	A2 / PD / VDDP3	JTAG Module Clock Input
	DAP0	I		Device Access Port Line 0
M20	XTAL1	I	XTAL1 / - / VDDP3	Main Oscillator/PLL/Clock Generator Input
M19	XTAL2	O	XTAL2 / - / VDDP3	Main Oscillator/PLL/Clock Generator Output

Table 2-72 Supply

Pin	Symbol	Ctrl	Type	Function
Y6	VAREF1	I	Vx	Positive Analog Reference Voltage 1
Y7	VAGND1	I	Vx	Negative Analog Reference Voltage 1

Package and Pinning Definitions TC297x Pin Definition and Functions:
Table 2-72 Supply (cont'd)

Pin	Symbol	Ctrl	Type	Function
T1	VAREF2	I	Vx	Positive Analog Reference Voltage 2
T2	VAGND2	I	Vx	Negative Analog Reference Voltage 2
Y5	VDDM	I	Vx	ADC Analog Power Supply (3.3V / 5V)
G8, H7	VDD / VDDSB	I	Vx	Emulation Device: Emulation SRAM Standby Power Supply (1.3V) (Emulation Device only). Production Device: VDD (1.3V).
P8, P13, N7, N14, H14, G13	VDD	I	Vx	Digital Core Power Supply (1.3V)
N19	VDD	I	Vx	Digital Core Power Supply (1.3V). The supply pin inturn supplies the main XTAL Oscillator/PLL (1.3V) . A higher decoupling capacitor is therefore recommended to the VSS pin for better noise immunity.
A2, B3, V19, W20	VEXT	I	Vx	External Power Supply (5V / 3.3V)
B18, A19	VDDP3	I	Vx	Digital Power Supply for Flash (3.3V). Can be also used as external 3.3V Power Supply for VFLEX.
N20	VDDP3	I	Vx	Digital Power Supply for Oscillator, LVDSH and A2 pads (3.3V). The supply pin inturn supplies the main XTAL Oscillator/PLL (3.3V) . A higher decoupling capacitor is therefore recommended to the VSS pin for better noise immunity.
E15, D16	VDDFL3	I	Vx	Flash Power Supply (3.3V)
D5	VFLEX	I	Vx	Digital Power Supply for Flex Port Pads (5V / 3.3V)
Y4	VSSM	I	Vx	Analog Ground for VDDM
T11	VEVRSB	I	Vx	Standby Power Supply (3.3V/5V) for the Standby SRAM (CPU0.DSPR). If Standby mode is not used: To be handled like VEXT (3.3V/5V).
B2, D4, E5, T16, U17, W19, Y20, E16, D17, B19, A20, L20	VSS	I	Vx	Digital Ground (outer balls)
P9, P12, N9, N10, N11, N12	VSS	I	Vx	Digital Ground (center balls)

Package and Pinning Definitions TC297x Pin Definition and Functions:

Table 2-72 Supply (cont'd)

Pin	Symbol	Ctrl	Type	Function
M7, M8, M10, M11, M13, M14	VSS	I	Vx	Digital Ground (center balls)
L8, L9, L10, L11, L12, L13	VSS	I	Vx	Digital Ground (center balls)
K8, K9, K10, K11, K12, K13	VSS	I	Vx	Digital Ground (center balls)
J7, J8, J10, J11, J13, J14	VSS	I	Vx	Digital Ground (center balls)
H9, H10, H11, H12, G9, G10, G11, G12	VSS	I	Vx	Digital Ground (center balls)
P10	VSS	I	Vx	Digital Ground (center balls) This ball is used in the Emulation Device as AGBT TX0N
P11	VSS	I	Vx	Digital Ground (center balls) This ball is used in the Emulation Device as AGBT TX0P
L7	VSS	I	Vx	Digital Ground (center balls) This ball is used in the Emulation Device as AGBT CLKN
K7	VSS	I	Vx	Digital Ground (center balls) This ball is used in the Emulation Device as AGBT CLKP
L14	VSS	I	Vx	Digital Ground (center balls) This ball is used in the Emulation Device as AGBT ERR
K14	NC / VDDPSB	I	NCVDD PSB	Emulation Device: Power Supply (3.3V) for DAP/JTAG pad group. Can be connected to VDDP or can be left unsupplied (see document 'AurixED' / Aurix Emulation Devices specification. Production Device: This pin is not connected on package level. It can be connected on PCB level to VDDP or Ground or can be left unsupplied.
A1, Y1, U4	NC	I	NC1	Not Connected. These pins are not connected on package level and will not be used for future extensions.

Package and Pinning Definitions TC297x Pin Definition and Functions:
Legend:

Column "Ctrl.":

 I = Input (for GPIO port Lines with IOCR bit field Selection PCx = 0XXX_B)

O = Output

 O0 = Output with IOCR bit field selection PCx = 1X000_B

 O1 = Output with IOCR bit field selection PCx = 1X001_B (ALT1)

 O2 = Output with IOCR bit field selection PCx = 1X010_B (ALT2)

 O3 = Output with IOCR bit field selection PCx = 1X011_B (ALT3)

 O4 = Output with IOCR bit field selection PCx = 1X100_B (ALT4)

 O5 = Output with IOCR bit field selection PCx = 1X101_B (ALT5)

 O6 = Output with IOCR bit field selection PCx = 1X110_B (ALT6)

 O7 = Output with IOCR bit field selection PCx = 1X111_B (ALT7)

Column "Type":

LP = Pad class LP (5V/3.3V, Class LP parameters for digital input / output and class D parameters for analog input function)

MP = Pad class MP (5V/3.3V)

MP+ = Pad class MP+ (5V/3.3V)

MPR = Pad class MPR (5V/3.3V)

A2 = Pad class A2 (3.3V)

LVDSM = Pad class LVDSM (5V/3.3V)

LVDSH = Pad class LVDSH (3.3V)

S = Pad class S (Class S parameters for digital input and class D parameters for analog input function)

D = Pad class D (VADC / DSADC)

 PU = with pull-up device connected during reset ($\overline{\text{PORST}} = 0$)

 PU1 = with pull-up device connected during reset ($\overline{\text{PORST}} = 0$)^{1) 2) 3)}

 PD = with pull-down device connected during reset ($\overline{\text{PORST}} = 0$)

 PD1 = with pull-down device connected during reset ($\overline{\text{PORST}} = 0$)^{1) 2) 3)}

PX = Behavior depends on usage: PD in EVR13 SMPS Mode and PU1 in GPIO Mode

 OD = open drain during reset ($\overline{\text{PORST}} = 0$)

 HighZ = tri-state during reset ($\overline{\text{PORST}} = 0$)

PORST = PORST input pad

XTAL1 = XTAL1 input pad

XTAL2 = XTAL2 input pad

VGATE1P = VGATE1P

VGATE3P = VGATE3P

Vx = Supply

NC = These pins are reserved for future extensions and shall not be connected externally

NC1 = These pins are not connected on package level and will not be used for future extensions

NCVDDPSB = This pin has a different functionality in an Production Device and an Emulation Device. For details pls. see Pin/Ball description of this pin.

NCVDDSB = This pin has a different functionality in an Production Device and an Emulation Device. For details pls. see Pin/Ball description of this pin.

1) The default state of GPIOs (Px.y) during and after PORST active is controlled via HWCFG[6] (P14.4). HWCFG[6] has a weak internal pull-up active at start-up if the pin is left unconnected. See also User's Manual, "Introduction Chapter", "General Purpose I/O Ports and Peripheral I/O Lines", Figure: "Default state of port pins during and after reset".

2) If HWCFG[6] is left unconnected or is externally pulled high, weak internal pull-ups (PU1) / pull-downs (PD1) are active during and after reset.

3) If HWCFG[6] is connected to ground, the PD1 / PU1 pins are predominantly in HighZ during and after reset.

2.3.2 Emergency Stop Function

The Emergency Stop function can be used to force GPIOs (General Purpose Inputs/Outputs) via an external input signal (EMGSTOPA or EMGSTOPB) into a defined state:

- Input state and
- PU or High-Z depending on HWCFG[6] level latched during Porst active

Control of the Emergency Stop function:

- The Emergency Stop function can be enabled/disabled in the SCU (see chapter “SCU”, “Emergency Stop Control”)
- The Emergency Stop input signal, EMGSTOPA (P33.8) / EMGSTOPB (P21.2), can be selected in the SCU (see chapter “SCU”, “Emergency Stop Control”)
- On port level, each GPIO can be enabled/disabled for the Emergency Stop function via the Px_ESR (Port x Emergency Stop) registers in the port control logic (see chapter “General Purpose I/O Ports and Peripheral I/O Lines”, “Emergency Stop Register”).

The Emergency Stop function is available for all GPIO Ports with the following exceptions:

- Not available for P20.2 (General Purpose Input/GPI only, overlaid with Testmode)
- Not available for P40.x (analogue input ANx overlaid with GPI)
- Not available for P32.0 EVR13 SMPS mode.
- Not available for dedicated I/O without General Purpose Output function (e.g ESRx, TMS, TCK)

The Emergency Stop function can be overruled on the following GPIO Ports:

- P00.x and P02.x: Emergency Stop can be overruled by the 8-Bit Standby Controller (SBR), if implemented. Overruling can be disabled via the control registers P00_SCR / P02_SCR (see chapter “General Purpose I/O Ports and Peripheral I/O Lines”, P00 / P01)
- P00.x: Emergency Stop can be overruled by the VADC. Overruling can be disabled via the control register P00_SCR (see chapter “General Purpose I/O Ports and Peripheral I/O Lines”, P00)
- P14.0 and P14.1: Emergency Stop can be overruled in the DXCPL mode (DAP over can physical layer mode). No Overruling in the DXCM (Debug over can message) mode
- P21.6: Emergency Stop can be overruled in JTAG mode if this pin is used as TDI
- P21.7: Emergency Stop can be overruled in JTAG or Three Pin DAP mode
- P20.0: Emergency Stop can be overruled in JTAG mode if this GPIO is used as TDI
- P33.8: Emergency Stop can be overruled if this pin is used as safety output pin (SMUFSP)

2.3.3 Pull-Up/Pull-Down Reset Behavior of the Pins

Table 2-73 List of Pull-Up/Pull-Down Reset Behavior of the Pins

Pins	$\overline{\text{PORST}} = 0$	$\overline{\text{PORST}} = 1$
all GPIOs	Pull-up if HWCFG[6] = 1 or High-Z if HWCFG[6] = 0	
TDI, $\overline{\text{TESTMODE}}$	Pull-up	
$\overline{\text{PORST}}^{1)}$	Pull-down with I_{PORST} relevant	Pull-down with I_{PDLI} relevant
$\overline{\text{TRST}}$, TCK, TMS	Pull-down	
ESR0	The open-drain driver is used to drive low. ²⁾	Pull-up ³⁾

Package and Pinning Definitions TC297x Pin Definition and Functions:

Table 2-73 List of Pull-Up/Pull-Down Reset Behavior of the Pins

Pins	$\overline{\text{PORST}} = 0$	$\overline{\text{PORST}} = 1$
ESR1	Pull-up ³⁾	
TDO	Pull-up	High-Z/Pull-up ⁴⁾

- 1) Pull-down with I_{PORST} relevant is always activated when a primary supply monitor detects a violation.
- 2) Valid additionally after deactivation of PORST until the internal reset phase has finished. See the SCU chapter for details.
- 3) See the SCU_IOCRR register description.
- 4) Depends on JTAG/DAP selection with $\overline{\text{TRST}}$.

In case of leakage test ($\overline{\text{PORST}} = 0$ and $\overline{\text{TESTMODE}} = 0$), the pull-down of the $\overline{\text{TRST}}$ pin is switched off. In case of an user application ($\overline{\text{TESTMODE}} = 1$), the pull-down of the $\overline{\text{TRST}}$ is always switched on.

2.4 TC29x Bare Die Pad Definition

The TC290 / TC297 / TC298 / TC299 BC-Step Bare Die Logic Symbol is shown in [Figure 2-4](#).

[Table 2-74](#) describes the pads of the TC290 / TC297 / TC298 / TC299 bare die. It describes also the mapping of VADC / DS-ADC channels to the analog inputs (ANx) and the mapping of Port functions to the pads.

The detailed description of the port functions (Px.y) can be found in the User's Manual chapter "General Purpose I/O Ports and Peripheral I/O Lines (Ports)".

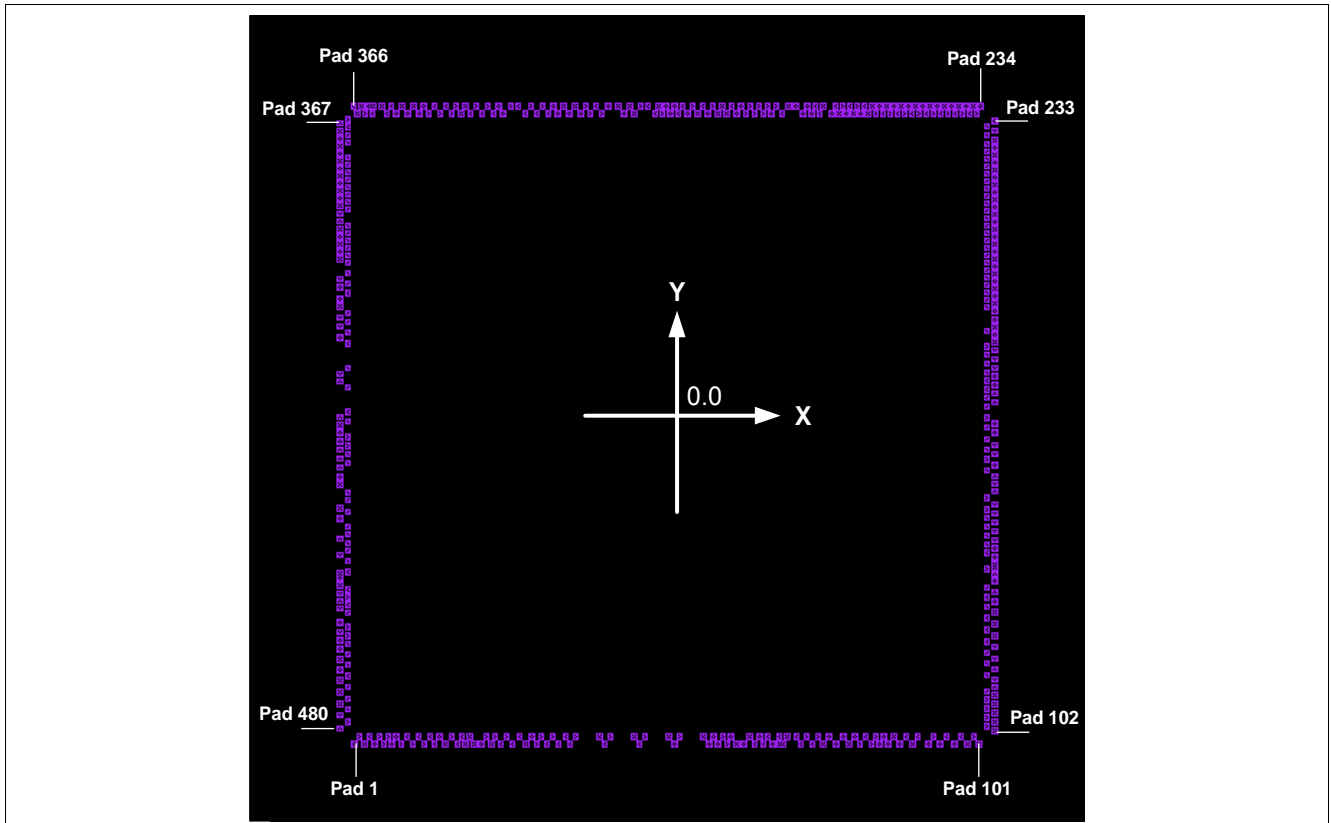

Figure 2-4 TC290 / TC297 / TC298 / TC299 Logic Symbol for the Bare Die.

Table 2-74 TC29x Bare Die Pad List

Number	Pad Name	Pad Type	X	Y	Comment
1	VEXT	Vx	-4328000	-4295000	Must be bonded to VEXT
2	P15.10	LP / PU1 / VEXT	-4123000	-4186500	GPIO
3	P15.2	MP / PU1 / VEXT	-4193000	-4295000	GPIO
4	P15.11	LP / PU1 / VEXT	-3983000	-4186500	GPIO
5	P15.4	MP / PU1 / VEXT	-4053000	-4295000	GPIO
6	P15.12	LP / PU1 / VEXT	-3863000	-4186500	GPIO
7	P15.1	LP / PU1 / VEXT	-3923000	-4295000	GPIO
8	P15.13	LP / PU1 / VEXT	-3753000	-4186500	GPIO
9	VSS	Vx	-3808000	-4295000	Must be bonded to VSS
10	P15.14	MP / PU1 / VEXT	-3603000	-4186500	GPIO
11	P15.3	MP / PU1 / VEXT	-3683000	-4295000	GPIO
12	P15.15	MP / PU1 / VEXT	-3443000	-4186500	GPIO

Package and Pinning Definitions TC29x Bare Die Pad Definition
Table 2-74 TC29x Bare Die Pad List (cont'd)

Number	Pad Name	Pad Type	X	Y	Comment
13	P15.5	MP / PU1 / VEXT	-3523000	-4295000	GPIO
14	P15.6	MP / PU1 / VEXT	-3283000	-4186500	GPIO
15	P15.7	MP / PU1 / VEXT	-3363000	-4295000	GPIO
16	P15.8	MP / PU1 / VEXT	-3153000	-4186500	GPIO
17	VEXT	Vx	-3218000	-4295000	Must be bonded to VEXT
18	P14.1	MP / PU1 / VEXT	-3073000	-4295000	GPIO
19	P14.0	MP+ / PU1 / VEXT	-2983000	-4186500	GPIO
20	P14.3	LP / PU1 / VEXT	-2843000	-4186500	GPIO
21	P14.2	LP / PU1 / VEXT	-2903000	-4295000	Must be bonded to VEXT if EVR13 active. Must be bonded to VSS if EVR13 inactive.
22	P14.4	LP / PU1 / VEXT	-2733000	-4186500	GPIO
23	VSS	Vx	-2788000	-4295000	Must be bonded to VSS
24	VDD	Vx	-2674000	-4295000	Must be bonded to VDD
25	VSS	Vx	-2574000	-4295000	Must be bonded to VSS
26	VDDFL3	Vx	-2505000	-4186500	Must be bonded to VDDP3
27	P14.11	LP / PU1 / VEXT	-2380000	-4186500	GPIO
28	VDDFL3	Vx	-2437500	-4295000	Must be bonded to VDDP3
29	P14.5	MP+ / PU1 / VEXT	-2300000	-4295000	GPIO
30	P14.12	LP / PU1 / VEXT	-2220000	-4186500	GPIO
31	P14.6	MP+ / PU1 / VEXT	-2140000	-4295000	GPIO
32	P14.13	MP+ / PU1 / VEXT	-2040000	-4186500	GPIO
33	P14.7	LP / PU1 / VEXT	-1960000	-4295000	GPIO
34	P14.14	MP+ / PU1 / VEXT	-1880000	-4186500	GPIO
35	VEXT	Vx	-1805000	-4295000	Must be bonded to VEXT
36	P14.8	LP / PU1 / VEXT	-1750000	-4186500	GPIO
37	P14.9	MP+ / PU1 / VEXT	-1670000	-4295000	GPIO
38	P14.15	LP / PU1 / VEXT	-1590000	-4186500	GPIO
39	P14.10	MP+ / PU1 / VEXT	-1510000	-4295000	GPIO
40	VDDFL3	Vx	-1410000	-4186500	Must be bonded to VDDP3
41	VSS	Vx	-1345000	-4295000	Must be bonded to VSS
42	P13.0	LVDSM_N / PU1 / VEXT	-1270000	-4186500	GPIO

Package and Pinning Definitions TC29x Bare Die Pad Definition
Table 2-74 TC29x Bare Die Pad List (cont'd)

Number	Pad Name	Pad Type	X	Y	Comment
43	P13.1	LVDSM_P / PU1 / VEXT	-940000	-4186500	GPIO
44	VEXT	Vx	-865000	-4295000	Must be bonded to VEXT
45	P13.2	LVDSM_N / PU1 / VEXT	-790000	-4186500	GPIO
46	P13.3	LVDSM_P / PU1 / VEXT	-460000	-4186500	GPIO
47	VSS	Vx	-385000	-4295000	Must be bonded to VSS
48	P13.4	LVDSM_N / PU1 / VEXT	-310000	-4186500	GPIO
49	P13.5	LVDSM_P / PU1 / VEXT	20000	-4186500	GPIO
50	VEXT	Vx	95000	-4295000	Must be bonded to VEXT
51	P13.6	LVDSM_N / PU1 / VEXT	170000	-4186500	GPIO
52	P13.7	LVDSM_P / PU1 / VEXT	500000	-4186500	GPIO
53	P13.11	LP / PU1 / VEXT	580000	-4295000	GPIO
54	P13.12	LP / PU1 / VEXT	640000	-4186500	GPIO
55	VDDP3	Vx	697500	-4295000	Must be bonded to VDDP3
56	VDDP3	Vx	765000	-4186500	Must be bonded to VDDP3
57	VEXT	Vx	830000	-4295000	Must be bonded to VEXT
58	VEXT	Vx	880000	-4186500	Must be bonded to VEXT
59	VDD	Vx	955000	-4295000	Must be bonded to VDD
60	VSS	Vx	1055000	-4295000	Must be bonded to VSS
61	P13.13	LP / PU1 / VEXT	1135000	-4186500	GPIO
62	P13.9	MP / PU1 / VEXT	1205000	-4295000	GPIO
63	P13.14	LP / PU1 / VEXT	1275000	-4186500	GPIO
64	VEXT	Vx	1330000	-4295000	Must be bonded to VEXT
65	P13.10	LP / PU1 / VEXT	1385000	-4186500	GPIO
66	VDDFL3	Vx	1455000	-4295000	Must be bonded to VDDP3
67	VSS	Vx	1575000	-4295000	Must be bonded to VSS (Double Pad / Center of Elephant Pad Opening)
68	VDDFL3	Vx	1542500	-4186500	Must be bonded to VDDP3
69	P13.15	LP / PU1 / VEXT	1660000	-4186500	GPIO
70	P12.0	LP / PU1 / VFLEX	1790000	-4186500	GPIO
71	P12.1	LP / PU1 / VFLEX	1850000	-4295000	GPIO

Package and Pinning Definitions TC29x Bare Die Pad Definition
Table 2-74 TC29x Bare Die Pad List (cont'd)

Number	Pad Name	Pad Type	X	Y	Comment
72	P11.0	MP+ / PU1 / VFLEX	1930000	-4186500	GPIO
73	VSS	Vx	2005000	-4295000	Must be bonded to VSS
74	P11.1	MP+ / PU1 / VFLEX	2080000	-4186500	GPIO
75	VFLEX	Vx	2155000	-4295000	Digital Power Supply for VFLEX Ports / Pads (5V / 3.3V)
76	P11.2	MPR/ PU1 / VFLEX	2230000	-4186500	GPIO
77	P11.4	MP+ / PU1 / VFLEX	2330000	-4295000	GPIO
78	P11.3	MPR/ PU1 / VFLEX	2430000	-4186500	GPIO
79	P11.5	LP / PU1 / VFLEX	2510000	-4295000	GPIO
80	P11.6	MPR/ PU1 / VFLEX	2590000	-4186500	GPIO
81	VSS	Vx	2665000	-4295000	Must be bonded to VSS
82	P11.9	MP+ / PU1 / VFLEX	2740000	-4186500	GPIO
83	P11.7	LP / PU1 / VFLEX	2820000	-4295000	GPIO
84	VFLEX	Vx	2935000	-4295000	Digital Power Supply for VFLEX Ports / Pads (5V / 3.3V)
85	P11.8	LP / PU1 / VFLEX	2880000	-4186500	GPIO
86	P11.13	LP / PU1 / VFLEX	3050000	-4295000	GPIO
87	P11.10	LP / PU1 / VFLEX	2990000	-4186500	GPIO
88	P11.11	MP+ / PU1 / VFLEX	3130000	-4186500	GPIO
89	VSS	Vx	3215000	-4295000	Must be bonded to VSS
90	P11.12	MPR/ PU1 / VFLEX	3300000	-4186500	GPIO
91	P11.14	LP / PU1 / VFLEX	3390000	-4295000	GPIO
92	P11.15	LP / PU1 / VFLEX	3460000	-4186500	GPIO
93	P10.0	LP / PU1 / VEXT	3610000	-4295000	GPIO
94	VEXT	Vx	3775000	-4295000	Must be bonded to VEXT

Package and Pinning Definitions TC29x Bare Die Pad Definition
Table 2-74 TC29x Bare Die Pad List (cont'd)

Number	Pad Name	Pad Type	X	Y	Comment
95	P10.9	LP / PU1 / VEXT	3680000	-4186500	GPIO
96	P10.1	MP+ / PU1 / VEXT	3865000	-4186500	GPIO
97	P10.3	MP / PU1 / VEXT	3970000	-4295000	GPIO
98	P10.4	MP+ / PU1 / VEXT	4150000	-4295000	GPIO
99	P10.10	LP / PU1 / VEXT	4055000	-4186500	GPIO
100	P10.2	MP / PU1 / VEXT	4310000	-4295000	GPIO
101	P10.11	LP / PU1 / VEXT	4240000	-4186500	GPIO
102	P10.13	LP / PU1 / VEXT	4419500	-4050000	GPIO
103	VSS	Vx	4528000	-4105000	Must be bonded to VSS
104	P10.14	LP / PU1 / VEXT	4419500	-3930000	GPIO
105	P10.5	LP / PU1 / VEXT	4528000	-3990000	GPIO
106	P10.15	LP / PU1 / VEXT	4419500	-3810000	GPIO
107	P10.6	LP / PU1 / VEXT	4528000	-3870000	GPIO
108	P02.13	LP / PU1 / VEXT	4419500	-3690000	GPIO
109	P10.8	LP / PU1 / VEXT	4528000	-3750000	GPIO
110	P10.7	LP / PU1 / VEXT	4419500	-3580000	GPIO
111	VEXT	Vx	4528000	-3635000	Must be bonded to VEXT
112	VDD	Vx	4528000	-3520000	Must be bonded to VDD
113	P02.12	LP / PU1 / VEXT	4419500	-3360000	GPIO
114	VSS	Vx	4528000	-3420000	Must be bonded to VSS
115	P02.0	MP+ / PU1 / VEXT	4528000	-3280000	GPIO
116	P02.14	LP / PU1 / VEXT	4419500	-3200000	GPIO
117	P02.1	LP / PU1 / VEXT	4528000	-3140000	GPIO
118	P02.15	MP+ / PU1 / VEXT	4419500	-3060000	GPIO
119	VSS	Vx	4528000	-2985000	Must be bonded to VSS
120	P02.2	MP+ / PU1 / VEXT	4419500	-2910000	GPIO
121	P02.3	LP / PU1 / VEXT	4528000	-2830000	GPIO
122	P02.4	MP+ / PU1 / VEXT	4419500	-2750000	GPIO
123	P02.9	LP / PU1 / VEXT	4528000	-2670000	GPIO
124	P02.5	MP+ / PU1 / VEXT	4419500	-2590000	GPIO
125	P02.10	LP / PU1 / VEXT	4528000	-2510000	GPIO
126	P02.6	MP / PU1 / VEXT	4419500	-2440000	GPIO
127	VEXT	Vx	4528000	-2375000	Must be bonded to VEXT

Package and Pinning Definitions TC29x Bare Die Pad Definition
Table 2-74 TC29x Bare Die Pad List (cont'd)

Number	Pad Name	Pad Type	X	Y	Comment
128	P02.7	MP / PU1 / VEXT	4419500	-2310000	GPIO
129	P02.11	LP / PU1 / VEXT	4528000	-2240000	GPIO
130	P02.8	LP / PU1 / VEXT	4419500	-2180000	GPIO
131	VDD	Vx	4528000	-2095000	Must be bonded to VDD
132	VSS	Vx	4528000	-1995000	Must be bonded to VSS
133	P01.0	LP / PU1 / VEXT	4419500	-1937500	GPIO
134	VSS	Vx	4528000	-1910000	Must be bonded to VSS (Double Pad / Center of Elephant Pad Opening)
135	VDD	Vx	4528000	-1780000	Must be bonded to VDD
136	P01.2	LP / PU1 / VEXT	4419500	-1715000	GPIO
137	VSS	Vx	4528000	-1660000	Must be bonded to VSS
138	P01.1	LP / PU1 / VEXT	4419500	-1605000	GPIO
139	P01.3	LP / PU1 / VEXT	4528000	-1545000	GPIO
140	P01.8	LP / PU1 / VEXT	4419500	-1485000	GPIO
141	P01.4	LP / PU1 / VEXT	4528000	-1425000	GPIO
142	P01.9	LP / PU1 / VEXT	4419500	-1365000	GPIO
143	P01.5	LP / PU1 / VEXT	4528000	-1305000	GPIO
144	P01.10	LP / PU1 / VEXT	4419500	-1245000	GPIO
145	VEXT	Vx	4528000	-1190000	Must be bonded to VEXT
146	P01.11	LP / PU1 / VEXT	4419500	-1135000	GPIO
147	P01.6	MP / PU1 / VEXT	4528000	-1065000	GPIO
148	P01.12	MP+ / PU1 / VEXT	4419500	-975000	GPIO
149	P01.7	MP / PU1 / VEXT	4528000	-885000	GPIO
150	VDD	Vx	4528000	-785000	Must be bonded to VDD
151	VSS	Vx	4528000	-685000	Must be bonded to VSS
152	P01.13	MP+ / PU1 / VEXT	4419500	-610000	GPIO
153	VSS	Vx	4528000	-535000	Must be bonded to VSS
154	P01.14	MP+ / PU1 / VEXT	4419500	-460000	GPIO
155	Reserved	Vx	4528000	-385000	Must be bonded to VSS
156	P01.15	LP / PU1 / VEXT	4419500	-330000	GPIO
157	VEXT	Vx	4528000	-265000	Must be bonded to VEXT
158	P00.13	MP+ / PU1 / VEXT	4419500	-190000	GPIO
159	P00.0	MP / PU1 / VEXT	4528000	-100000	GPIO
160	P00.14	LP / PU1 / VEXT	4419500	-30000	GPIO
161	VSS	Vx	4528000	25000	Must be bonded to VSS

Package and Pinning Definitions TC29x Bare Die Pad Definition
Table 2-74 TC29x Bare Die Pad List (cont'd)

Number	Pad Name	Pad Type	X	Y	Comment
162	P00.15	MP+ / PU1 / VEXT	4419500	100000	GPIO
163	P00.1 (VADC7.5 / DS5NA)	D	4419500	250000	Analog input
164	P00.2 (VADC7.4 / DS5PA)	D	4528000	310000	Analog input
165	P00.3 (VADC7.3)	D	4419500	370000	Analog input
166	VSS	Vx	4528000	425000	Must be bonded to VSS
167	P00.4 (VADC7.2)	D	4419500	480000	Analog input
168	P00.5 (VADC7.1)	D	4528000	540000	Analog input
169	P00.6 (VADC7.0)	D	4419500	600000	Analog input
170	VEXT	Vx	4528000	655000	Must be bonded to VEXT
171	P00.7 (VADC6.5 / DS4NA)	D	4419500	710000	Analog input
172	P00.8 (VADC6.4 / DS4PA)	D	4528000	770000	Analog input
173	P00.9 (VADC6.3)	D	4419500	830000	Analog input
174	P00.10 (VADC6.2)	D	4528000	890000	Analog input
175	P00.11 (VADC6.1)	D	4419500	950000	Analog input
176	VSS	Vx	4528000	1005000	Must be bonded to VSS
177	P00.12 (VADC6.0)	D	4419500	1060000	Analog input
178	VDD	Vx	4528000	1115000	Must be bonded to VDD
179	VSS	Vx	4528000	1215000	Must be bonded to VSS
180	VEXT	Vx	4419500	1265000	Must be bonded to VEXT
181	VSS	Vx	4528000	1315000	Must be bonded to VSS
182	VDD	Vx	4528000	1415000	Must be bonded to VDD
183	VAREF4	Vx	4528000	1535000	Positive Analog Reference Voltage 4
184	VAGND4	Vx	4419500	1585000	Negative Analog Reference Voltage 4
185	VDDM	Vx	4528000	1635000	Must be bonded to VEXT
186	AN47 (VADC5.7 / DS3ND)	S	4419500	1685000	Analog input
187	AN46 (VADC5.6 / DS3PD)	S	4528000	1735000	Analog input
188	AN45 (VADC5.5 / DS3NC)	S	4419500	1785000	Analog input

Package and Pinning Definitions TC29x Bare Die Pad Definition
Table 2-74 TC29x Bare Die Pad List (cont'd)

Number	Pad Name	Pad Type	X	Y	Comment
189	AN44 (VADC5.4 / DS3PC)	S	4528000	1835000	Analog input
190	AN43 (VADC5.3)	D	4419500	1885000	Analog input (with pull down diagnostics)
191	AN42 (VADC5.2)	D	4528000	1935000	Analog input
192	AN41 (VADC5.1)	D	4419500	1985000	Analog input
193	AN40 (VADC5.0)	D	4528000	2035000	Analog input
194	AN38 (VADC4.6 / DS3PB), P40.8 (SENT8A)	S	4528000	2135000	Analog input, GPI (SENT)
195	AN39 (VADC4.7 / DS3NB), P40.9 (SENT9A)	S	4419500	2085000	Analog input, GPI (SENT)
196	AN36 (VADC4.4 / DS3PA), P40.6 (SENT6A)	S	4528000	2235000	Analog input, GPI (SENT)
197	AN37 (VADC4.5 / DS3NA), P40.7 (SENT7A)	S	4419500	2185000	Analog input, GPI (SENT)
198	AN34 (VADC4.2)	D	4528000	2335000	Analog input
199	AN35 (VADC4.3)	D	4419500	2285000	Analog input (with pull down diagnostics)
200	AN32 (VADC4.0), P40.4 (SENT4A)	S	4528000	2435000	Analog input, GPI (SENT)
201	AN33 (VADC4.1), P40.5 (SENT5A)	S	4419500	2385000	Analog input, GPI (SENT)
202	AN70 (VADC10.6 / DS9PA), P40.13 (SENT13A)	S	4528000	2535000	Analog input, GPI (SENT)
203	AN71 (VADC10.7 / DS9NA), P40.14 (SENT14A)	S	4419500	2485000	Analog input, GPI (SENT)
204	AN68 (VADC10.4 / DS8PA), P40.11 (SENT11A)	S	4528000	2635000	Analog input, GPI (SENT)
205	AN69 (VADC10.5 / DS8NA), P40.12 (SENT12A)	S	4419500	2585000	Analog input, GPI (SENT)

Package and Pinning Definitions TC29x Bare Die Pad Definition
Table 2-74 TC29x Bare Die Pad List (cont'd)

Number	Pad Name	Pad Type	X	Y	Comment
206	VDDM	Vx	4528000	2735000	Must be bonded to VEXT
207	AN67 (VADC10.3 / DS8NB), P40.10 (SENT10A)	S	4419500	2685000	Analog input, GPI (SENT)
208	VSSM	Vx	4528000	2835000	Must be bonded to VSS
209	VSS	Vx	4419500	2785000	Must be bonded to VSS
210	AN65 (VADC10.1)	D	4528000	2935000	Analog input
211	AN66 (VADC10.2 / DS8PB)	D	4419500	2885000	Analog input
212	AN63 (VADC9.7 / DS7NB)	D	4528000	3035000	Analog input
213	AN64 (VADC10.0)	D	4419500	2985000	Analog input
214	AN61 (VADC9.5 / DS7NA)	D	4528000	3135000	Analog input
215	AN62 (VADC9.6 / DS7PB)	D	4419500	3085000	Analog input
216	AN59 (VADC9.3)	D	4528000	3235000	Analog input
217	AN60 (VADC9.4 / DS7PA)	D	4419500	3185000	Analog input
218	AN57 (VADC9.1)	D	4528000	3335000	Analog input
219	AN58 (VADC9.2)	D	4419500	3285000	Analog input
220	VAREF3	Vx	4528000	3435000	Positive Analog Reference Voltage 3
221	AN56 (VADC9.0)	D	4419500	3385000	Analog input
222	VAGND3	Vx	4528000	3535000	Negative Analog Reference Voltage 3
223	VAREF2	Vx	4419500	3485000	Positive Analog Reference Voltage 2
224	AN55 (VADC8.7 / DS6NB)	D	4528000	3635000	Analog input
225	VAGND2	Vx	4419500	3585000	Negative Analog Reference Voltage 2
226	AN53 (VADC8.5 / DS6NA)	D	4528000	3735000	Analog input
227	AN54 (VADC8.6 / DS6PB)	D	4419500	3685000	Analog input
228	AN51 (VADC8.3)	D	4528000	3835000	Analog input

Package and Pinning Definitions TC29x Bare Die Pad Definition
Table 2-74 TC29x Bare Die Pad List (cont'd)

Number	Pad Name	Pad Type	X	Y	Comment
229	AN52 (VADC8.4/ DS6PA)	D	4419500	3785000	Analog input
230	AN49 (VADC8.1)	D	4528000	3960000	Analog input
231	AN50 (VADC8.2)	D	4419500	3897400	Analog input
232	VDDM	Vx	4528000	4085000	Must be bonded to VEXT
233	AN48 (VADC8.0)	D	4419500	4022600	Analog input
234	AN31 (VADC3.7)	D	4278000	4186500	Analog input
235	VSSM	Vx	4328000	4295000	Must be bonded to VSS
236	AN29 (VADC3.5)	D	4178000	4186500	Analog input
237	AN30 (VADC3.6)	D	4228000	4295000	Analog input
238	AN27 (VADC3.3), P40.3 (SENT3A)	S	4078000	4186500	Analog input (with pull down diagnostics), GPI (SENT)
239	AN28 (VADC3.4)	D	4128000	4295000	Analog input
240	AN25 (VADC3.1/ DS2NB), P40.2 (SENT1A)	S	3978000	4186500	Analog input, GPI (SENT)
241	AN26 (VADC3.2), P40.2 (SENT2A)	S	4028000	4295000	Analog input, GPI (SENT)
242	AN23 (VADC2.7)	D	3878000	4186500	Analog input
243	AN24 (VADC3.0/ DS2PB), P40.0 (SENT0A)	S	3928000	4295000	Analog input, GPI (SENT)
244	AN21 (VADC2.5/ DS2NA)	D	3778000	4186500	Analog input
245	AN22 (VADC2.6)	D	3828000	4295000	Analog input
246	AN19 (VADC2.3)	D	3678000	4186500	Analog input (with pull down diagnostics)
247	AN20 (VADC2.4/ DS2PA)	D	3728000	4295000	Analog input
248	AN17 (VADC2.1)	D	3578000	4186500	Analog input
249	AN18 (VADC2.2)	D	3628000	4295000	Analog input
250	AN15 (VADC1.7)	D	3478000	4186500	Analog input
251	AN16 (VADC2.0)	D	3528000	4295000	Analog input
252	VAGND0	Vx	3378000	4186500	Negative Analog Reference Voltage 0
253	VAGND1	Vx	3428000	4295000	Negative Analog Reference Voltage 1
254	VAREF0	Vx	3278000	4186500	Positive Analog Reference Voltage 0

Package and Pinning Definitions TC29x Bare Die Pad Definition
Table 2-74 TC29x Bare Die Pad List (cont'd)

Number	Pad Name	Pad Type	X	Y	Comment
255	VAREF1	Vx	3328000	4295000	Positive Analog Reference Voltage 1
256	VSS	Vx	3178000	4186500	Must be bonded to VSS
257	VSSM	Vx	3228000	4295000	Must be bonded to VSS
258	AN14 (VADC1.6)	D	3078000	4186500	Analog input
259	VDDM	Vx	3128000	4295000	Must be bonded to VEXT
260	AN12 (VADC1.4)	D	2978000	4186500	Analog input
261	AN13 (VADC1.5)	D	3028000	4295000	Analog input
262	AN10 (VADC1.2)	D	2878000	4186500	Analog input
263	AN11 (VADC1.3)	D	2928000	4295000	Analog input (with pull down diagnostics)
264	AN8 (VADC1.0)	D	2778000	4186500	Analog input
265	AN9 (VADC1.1)	D	2828000	4295000	Analog input
266	AN6 (VADC0.6)	D	2678000	4186500	Analog input
267	AN7 (VADC0.7)	D	2728000	4295000	Analog input (with pull down diagnostics)
268	AN4 (VADC0.4)	D	2578000	4186500	Analog input
269	AN5 (VADC0.5)	D	2628000	4295000	Analog input
270	AN2 (VADC0.2 / DS0PA)	D	2478000	4186500	Analog input
271	AN3 (VADC0.3 / DS0NA)	D	2528000	4295000	Analog input
272	AN1 (VADC0.1 / DS1NA)	D	2378000	4186500	Analog input
273	VSSM	Vx	2428000	4295000	Must be bonded to VSS
274	AN0 (VADC0.0 / DS1PA)	D	2278000	4186500	Analog input
275	VDDM	Vx	2328000	4295000	Must be bonded to VEXT
276	EVR_OFF	Vx	2158000	4295000	Must be bonded to VSS
277	P33.0	LP / PU1 / VEXT	2103000	4186500	GPIO
278	VSS	Vx	2048000	4295000	Must be bonded to VSS
279	P33.1	LP / PU1 / VEXT	1993000	4186500	GPIO
280	P34.1	LP / PU1 / VEXT	1933000	4295000	GPIO
281	P33.2	LP / PU1 / VEXT	1873000	4186500	GPIO
282	VSS	Vx	1778000	4295000	Must be bonded to VSS
283	VDD	Vx	1678000	4295000	Must be bonded to VDD
284	P33.3	LP / PU1 / VEXT	1583000	4186500	GPIO
285	VEXT	Vx	1509000	4295000	Must be bonded to VEXT
286	VEXT	Vx	1440000	4186500	Must be bonded to VEXT
287	P34.2	LP / PU1 / VEXT	1385000	4295000	GPIO

Package and Pinning Definitions TC29x Bare Die Pad Definition
Table 2-74 TC29x Bare Die Pad List (cont'd)

Number	Pad Name	Pad Type	X	Y	Comment
288	P33.4	LP / PU1 / VEXT	1325000	4186500	GPIO
289	P34.3	LP / PU1 / VEXT	1265000	4295000	GPIO
290	P33.5	LP / PU1 / VEXT	1205000	4186500	GPIO
291	P34.4	LP / PU1 / VEXT	1145000	4295000	GPIO
292	P33.6	LP / PU1 / VEXT	1085000	4186500	GPIO
293	P34.5	LP / PU1 / VEXT	1015000	4295000	GPIO
294	P33.7	LP / PU1 / VEXT	955000	4186500	GPIO
295	P33.8	MP / HighZ / VEXT	885000	4295000	GPIO
296	P33.9	LP / PU1 / VEXT	815000	4186500	GPIO
297	VSS	Vx	760000	4295000	Must be bonded to VSS
298	P33.10	MP / PU1 / VEXT	695000	4186500	GPIO
299	P33.14	LP / PU1 / VEXT	625000	4295000	GPIO
300	P33.11	MP / PU1 / VEXT	555000	4186500	GPIO
301	P33.15	LP / PU1 / VEXT	485000	4295000	GPIO
302	P33.12	MP / PU1 / VEXT	415000	4186500	GPIO
303	P32.5	LP / PU1 / VEXT	345000	4295000	GPIO
304	P33.13	MP / PU1 / VEXT	275000	4186500	GPIO
305	P32.6	LP / PU1 / VEXT	205000	4295000	GPIO
306	VGATE3P (LDO)	VGATE3P	150000	4186500	Must be bonded to VSS
307	VEXT	Vx	96000	4295000	Must be bonded to VEXT
308	P32.0	LP / EVR13 SMPS -> PD, GPIO -> PU1 / VEXT	37000	4186500	GPIO
309	VGATE1N (SMPS)	VGATE1N	-18000	4295000	Must be bonded to VSS if EVR13 SMPS is not used. Must be bonded to NMOS gate if EVR13 SMPS is used.
310	VGATE1P (SMPS)	VGATE1P	-68000	4186500	Must be bonded to VEXT if EVR13 SMPS is not used. Must be bonded to PMOS gate if EVR13 SMPS is used.
311	VGATE1P (LDO)	VGATE1P	-118000	4295000	VGATE1P (LDO)
312	P32.2	LP / PU1 / VEXT	-173000	4186500	GPIO
313	VSS	Vx	-268000	4295000	Must be bonded to VSS
314	VDD	Vx	-368000	4295000	Must be bonded to VDD
315	P32.3	LP / PU1 / VEXT	-463000	4186500	GPIO
316	P32.7	LP / PU1 / VEXT	-523000	4295000	GPIO

Package and Pinning Definitions TC29x Bare Die Pad Definition
Table 2-74 TC29x Bare Die Pad List (cont'd)

Number	Pad Name	Pad Type	X	Y	Comment
317	P32.4	MP+ / PU1 / VEXT	-603000	4186500	GPIO
318	VSS	Vx	-678000	4295000	Must be bonded to VSS
319	P31.0	MP / PU1 / VFLEXE	-823000	4295000	GPIO
320	P31.1	MP / PU1 / VFLEXE	-903000	4186500	GPIO
321	P31.2	MP / PU1 / VFLEXE	-983000	4295000	GPIO
322	P31.3	MP / PU1 / VFLEXE	-1063000	4186500	GPIO
323	VSS	Vx	-1128000	4295000	Must be bonded to VSS
324	P31.4	MP / PU1 / VFLEXE	-1193000	4186500	GPIO
325	P31.5	MP / PU1 / VFLEXE	-1273000	4295000	GPIO
326	P31.6	MP / PU1 / VFLEXE	-1353000	4186500	GPIO
327	P31.7	MP / PU1 / VFLEXE	-1433000	4295000	GPIO
328	P31.8	MP / PU1 / VFLEXE	-1513000	4186500	GPIO
329	VFLEXE	Vx	-1578000	4295000	Must be bonded to VEXT or VDDP3
330	P31.9	MP / PU1 / VFLEXE	-1643000	4186500	GPIO
331	P31.10	MP / PU1 / VFLEXE	-1723000	4295000	GPIO
332	P31.14	MP / PU1 / VFLEXE	-1803000	4186500	GPIO
333	P31.15	MP / PU1 / VFLEXE	-1883000	4295000	GPIO
334	P31.11	MP / PU1 / VFLEXE	-1963000	4186500	GPIO
335	VSS	Vx	-2068000	4295000	Must be bonded to VSS
336	VDD	Vx	-2168000	4295000	Must be bonded to VDD
337	P31.12	MP / PU1 / VFLEXE	-2273000	4186500	GPIO
338	VSS	Vx	-2338000	4295000	Must be bonded to VSS
339	P31.13	MP / PU1 / VFLEXE	-2403000	4186500	GPIO

Package and Pinning Definitions TC29x Bare Die Pad Definition
Table 2-74 TC29x Bare Die Pad List (cont'd)

Number	Pad Name	Pad Type	X	Y	Comment
340	P30.0	MP / PU1 / VFLEXE	-2483000	4295000	GPIO
341	P30.1	MP / PU1 / VFLEXE	-2563000	4186500	GPIO
342	P30.2	MP / PU1 / VFLEXE	-2643000	4295000	GPIO
343	VFLEXE	Vx	-2788000	4295000	Must be bonded to VEXT or VDDP3
344	P30.3	MP / PU1 / VFLEXE	-2723000	4186500	GPIO
345	VSS	Vx	-2918000	4295000	Must be bonded to VSS
346	P30.4	MP / PU1 / VFLEXE	-2853000	4186500	GPIO
347	P30.5	MP / PU1 / VFLEXE	-2983000	4186500	GPIO
348	P30.6	MP / PU1 / VFLEXE	-3063000	4295000	GPIO
349	P30.8	MP / PU1 / VFLEXE	-3223000	4295000	GPIO
350	P30.7	MP / PU1 / VFLEXE	-3143000	4186500	GPIO
351	VFLEXE	Vx	-3368000	4295000	Must be bonded to VEXT or VDDP3
352	P30.9	MP / PU1 / VFLEXE	-3303000	4186500	GPIO
353	P30.11	MP / PU1 / VFLEXE	-3513000	4295000	GPIO
354	P30.10	MP / PU1 / VFLEXE	-3433000	4186500	GPIO
355	P30.15	MP / PU1 / VFLEXE	-3673000	4295000	GPIO
356	P30.12	MP / PU1 / VFLEXE	-3593000	4186500	GPIO
357	VSS	Vx	-3818000	4295000	Must be bonded to VSS
358	P30.13	MP / PU1 / VFLEXE	-3753000	4186500	GPIO
359	P26.0	LP / PU1 / VFLEXE	-3953000	4295000	GPIO
360	P30.14	MP / PU1 / VFLEXE	-3883000	4186500	GPIO
361	VSS	Vx	-4098000	4295000	Must be bonded to VSS (Double Pad / Center of Elephant Pad Opening)

Package and Pinning Definitions TC29x Bare Die Pad Definition
Table 2-74 TC29x Bare Die Pad List (cont'd)

Number	Pad Name	Pad Type	X	Y	Comment
362	P25.0	A2 / PU1 / VEBU	-4078000	4186500	GPIO
363	P25.2	A2 / PU1 / VEBU	-4228000	4295000	GPIO
364	P25.1	A2 / PU1 / VEBU	-4178000	4186500	GPIO
365	P25.4	A2 / PU1 / VEBU	-4338000	4295000	GPIO
366	P25.3	A2 / PU1 / VEBU	-4288000	4186500	GPIO
367	P25.5	A2 / PU1 / VEBU	-4419500	4105000	GPIO
368	P25.7	A2 / PU1 / VEBU	-4419500	4005000	GPIO
369	VEBU	Vx	-4528000	4055000	Must be bonded to VEXT or VDDP3
370	P25.8	A2 / PU1 / VEBU	-4419500	3905000	GPIO
371	VSS	Vx	-4528000	3955000	Must be bonded to VSS
372	P25.10	A2 / PU1 / VEBU	-4419500	3805000	GPIO
373	P25.9	A2 / PU1 / VEBU	-4528000	3855000	GPIO
374	VSS	Vx	-4528000	3755000	Must be bonded to VSS
375	P25.11	A2 / PU1 / VEBU	-4419500	3605000	GPIO
376	VDD	Vx	-4528000	3655000	Must be bonded to VDD
377	P25.13	A2 / PU1 / VEBU	-4419500	3505000	GPIO
378	P25.12	A2 / PU1 / VEBU	-4528000	3555000	GPIO
379	P25.14	A2 / PU1 / VEBU	-4419500	3405000	GPIO
380	VEBU	Vx	-4528000	3455000	Must be bonded to VEXT or VDDP3
381	P25.6	A2 / PU1 / VEBU	-4419500	3305000	GPIO
382	P25.15	A2 / PU1 / VEBU	-4528000	3355000	GPIO
383	P24.1	A2 / PU1 / VEBU	-4419500	3205000	GPIO
384	P24.0	A2 / PU1 / VEBU	-4528000	3255000	GPIO
385	P24.2	A2 / PU1 / VEBU	-4419500	3105000	GPIO
386	VSS	Vx	-4528000	3155000	Must be bonded to VSS
387	P24.4	A2 / PU1 / VEBU	-4419500	3005000	GPIO
388	P24.3	A2 / PU1 / VEBU	-4528000	3055000	GPIO
389	P24.6	A2 / PU1 / VEBU	-4419500	2905000	GPIO
390	P24.5	A2 / PU1 / VEBU	-4528000	2955000	GPIO
391	VSS	Vx	-4528000	2845000	Must be bonded to VSS
392	P24.7	A2 / PU1 / VEBU	-4419500	2685000	GPIO
393	VDD	Vx	-4528000	2745000	Must be bonded to VDD
394	P24.8	A2 / PU1 / VEBU	-4419500	2585000	GPIO
395	VEBU	Vx	-4528000	2635000	Must be bonded to VEXT or VDDP3
396	P24.10	A2 / PU1 / VEBU	-4419500	2485000	GPIO
397	P24.9	A2 / PU1 / VEBU	-4528000	2535000	GPIO

Package and Pinning Definitions TC29x Bare Die Pad Definition
Table 2-74 TC29x Bare Die Pad List (cont'd)

Number	Pad Name	Pad Type	X	Y	Comment
398	P24.12	A2 / PU1 / VEBU	-4419500	2385000	GPIO
399	P24.11	A2 / PU1 / VEBU	-4528000	2435000	GPIO
400	P24.13	A2 / PU1 / VEBU	-4419500	2285000	GPIO
401	VSS	Vx	-4528000	2335000	Must be bonded to VSS
402	P24.15	A2 / PU1 / VEBU	-4419500	2185000	GPIO
403	P24.14	A2 / PU1 / VEBU	-4528000	2235000	GPIO
404	P23.5	MP+ / PU1 / VEXT	-4419500	2040000	GPIO
405	VSS	Vx	-4528000	1965000	Must be bonded to VSS
406	P23.0	LP / PU1 / VEXT	-4419500	1910000	GPIO
407	VEXT	Vx	-4528000	1855000	Must be bonded to VEXT
408	P23.1	MP+ / PU1 / VEXT	-4419500	1780000	GPIO
409	VDD	Vx	-4528000	1695000	Must be bonded to VDD
410	VSS	Vx	-4528000	1595000	Must be bonded to VSS
411	P23.2	LP / PU1 / VEXT	-4419500	1510000	GPIO
412	P23.6	LP / PU1 / VEXT	-4528000	1450000	GPIO
413	P23.3	LP / PU1 / VEXT	-4419500	1390000	GPIO
414	P23.7	LP / PU1 / VEXT	-4528000	1330000	GPIO
415	P23.4	MP+ / PU1 / VEXT	-4419500	1250000	GPIO
416	VSS	Vx	-4528000	1175000	Must be bonded to VSS
417	P22.0	LVDSM_N / PU1 / VEXT	-4419500	1100000	GPIO
418	P22.1	LVDSM_P / PU1 / VEXT	-4419500	770000	GPIO
419	VSS	Vx	-4528000	688000	Must be bonded to VSS
420	VDD	Vx	-4528000	588000	Must be bonded to VDD
421	P22.2	LVDSM_N / PU1 / VEXT	-4419500	513000	GPIO
422	P22.3	LVDSM_P / PU1 / VEXT	-4419500	183000	GPIO
423	VEXT	Vx	-4528000	108000	Must be bonded to VEXT
424	P22.4	LP / PU1 / VEXT	-4419500	53000	GPIO
425	VSS	Vx	-4528000	-2000	Must be bonded to VSS
426	VDD	Vx	-4528000	-102000	Must be bonded to VDD
427	P22.5	LP / PU1 / VEXT	-4419500	-157000	GPIO
428	P22.7	LP / PU1 / VEXT	-4528000	-217000	GPIO
429	P22.6	LP / PU1 / VEXT	-4419500	-277000	GPIO
430	VSS	Vx	-4528000	-332000	Must be bonded to VSS

Package and Pinning Definitions TC29x Bare Die Pad Definition
Table 2-74 TC29x Bare Die Pad List (cont'd)

Number	Pad Name	Pad Type	X	Y	Comment
431	P22.8	LP / PU1 / VEXT	-4419500	-387000	GPIO
432	P22.9	LP / PU1 / VEXT	-4528000	-447000	GPIO
433	P22.10	LP / PU1 / VEXT	-4419500	-507000	GPIO
434	P22.11	LP / PU1 / VEXT	-4528000	-567000	GPIO
435	VDDOSC	Vx	-4528000	-702000	Must be bonded to VSS
436	VSSOSC	Vx	-4528000	-802000	Must be bonded to VSS
437	XTAL1	XTAL1	-4419500	-909500	Main Oscillator/PLL/Clock Generator Input. Must be bonded to external quartz or resonator.
438	XTAL2	XTAL2	-4419500	-1009500	Main Oscillator/PLL/Clock Generator Input. Must be bonded to external quartz or resonator.
439	VSSOSC	Vx	-4528000	-1117000	Must be bonded to VSS
440	VDDOSC3	Vx	-4419500	-1167000	Must be bonded to VDDP3
441	VDDP3	Vx	-4528000	-1257000	Must be bonded to VDDP3
442	P21.0	LVDSH_N / PU1 / VDDP3	-4419500	-1362500	GPIO
443	P21.1	LVDSH_P / PU1 / VDDP3	-4419500	-1462500	GPIO
444	VSSP	Vx	-4528000	-1525000	Must be bonded to VSS
445	P21.2	LVDSH_N / PU1 / VDDP3	-4419500	-1587500	GPIO
446	P21.3	LVDSH_P / PU1 / VDDP3	-4419500	-1687500	GPIO
447	VDDP3	Vx	-4528000	-1750000	Must be bonded to VDDP3
448	P21.4	LVDSH_N / PU1 / VDDP3	-4419500	-1824500	GPIO
449	VSS	Vx	-4528000	-2020000	Must be bonded to VSS (Double Pad / Center of Elephant Pad Opening)
450	P21.5	LVDSH_P / PU1 / VDDP3	-4419500	-1975500	GPIO
451	VDD	Vx	-4528000	-2150000	Must be bonded to VDD
452	VSSP	Vx	-4528000	-2260000	Must be bonded to VSS
453	P21.6	A2 / PU / VDDP3	-4419500	-2210000	GPIO, TDI
454	VDDP3	Vx	-4528000	-2360000	Must be bonded to VDDP3
455	TMS /DAP1	A2 / PD / VDDP3	-4419500	-2310000	JTAG Module State Machine Control Input / Device Access Port Line 1

Package and Pinning Definitions TC29x Bare Die Pad Definition
Table 2-74 TC29x Bare Die Pad List (cont'd)

Number	Pad Name	Pad Type	X	Y	Comment
456	TCK /DAP0	A2 / PD / VDDP3	-4528000	-2460000	JTAG Module Clock Input / Device Access Port Line 0
457	P21.7	A2 / PU / VDDP3	-4419500	-2410000	GPIO, TDO
458	TRST (N)	A2 / PD / VDDP3	-4419500	-2520000	JTAG Module Reset/Enable Input
459	Reserved	Vx	-4528000	-2650000	Must be bonded to VSS
460	VEXT	Vx	-4528000	-2780000	Must be bonded to VEXT
461	P20.0	MP / PU1 / VEXT	-4419500	-2715000	GPIO
462	VSS	Vx	-4528000	-2890000	Must be bonded to VSS
463	P20.1	LP / PU1 / VEXT	-4419500	-2835000	GPIO
464	PORST (N)	PORST / PD / VEXT	-4528000	-3007500	Power On Reset Input. Additional strong PD in case of power fail.
465	P20.2	LP / PU1 / VEXT	-4419500	-2940000	Testmode pin must be bonded
466	ESR1 (N) /EVRWUP	MP / PU1 / VEXT	-4528000	-3150000	External System Request Reset 1. Default NMI function. EVR Wakeup Pin.
467	P20.3	LP / PU1 / VEXT	-4419500	-3080000	GPIO
468	ESR0 (N) /EVRWUP	MP / OD	-4528000	-3290000	External System Request Reset 0. Default configuration during and after reset is open-drain driver. The driver drives low during power-on reset. EVR Wakeup Pin.
469	P20.7	LP / PU1 / VEXT	-4419500	-3220000	GPIO
470	VEXT	Vx	-4528000	-3435000	Must be bonded to VEXT
471	P20.8	MP / PU1 / VEXT	-4419500	-3370000	GPIO
472	P20.6	LP / PU1 / VEXT	-4528000	-3590000	GPIO
473	P20.10	MP / PU1 / VEXT	-4419500	-3520000	GPIO
474	P20.9	LP / PU1 / VEXT	-4528000	-3750000	GPIO
475	P20.11	MP / PU1 / VEXT	-4419500	-3680000	GPIO
476	VSS	Vx	-4528000	-3905000	Must be bonded to VSS
477	P20.12	MP / PU1 / VEXT	-4419500	-3820000	GPIO
478	P20.14	MP / PU1 / VEXT	-4528000	-4080000	GPIO
479	P20.13	MP / PU1 / VEXT	-4419500	-3990000	GPIO
480	P15.0	LP / PU1 / VEXT	-4263000	-4186500	GPIO

Legend:

Column "Number":

Running number of pads in the pad frame

Column “**Name**”:

Symbolic name of the pad.

The functions mapped on GPIO pads “Px.y” are described in the User’s Manual chapter “General Purpose I/O Ports and Peripheral I/O Lines (Ports)”

Column “**Type**”:

LP = Pad class LP (5V/3.3V, Class LP parameters for digital input / output and class D parameters for analog input function)

MP = Pad class MP (5V/3.3V)

MP+ = Pad class MP+ (5V/3.3V)

MPR = Pad class MPR (5V/3.3V)

A2 = Pad class A2 (3.3V)

LVDSM = Pad class LVDSM (5V/3.3V)

LVDSH = Pad class LVDSH (3.3V)

S = Pad class S (Class S parameters for digital input and class D parameters for analog input function)

D = Pad class D (VADC / DSADC)

PU = with pull-up device connected during reset ($\overline{\text{PORST}} = 0$)

PU1 = with pull-up device connected during reset ($\overline{\text{PORST}} = 0$)^{1) 2) 3)}

PD = with pull-down device connected during reset ($\overline{\text{PORST}} = 0$)

PD1 = with pull-down device connected during reset ($\overline{\text{PORST}} = 0$)^{1) 2) 3)}

PX = Behavior depends on usage: PD in EVR13 SMPS Mode and PU1 in GPIO Mode

OD = open drain during reset ($\overline{\text{PORST}} = 0$)

HighZ = tri-state during reset ($\overline{\text{PORST}} = 0$)

PORST = PORST input pad

XTAL1 = XTAL1 input pad

XTAL2 = XTAL2 input pad

VGATE1P = VGATE1P

VGATE3P = VGATE3P

Vx = Supply

NC = These pins are reserved for future extensions and shall not be connected externally

NC1 = These pins are not connected on package level and will not be used for future extensions

NCVDDPSB = This pin has a different functionality in an Production Device and an Emulation Device. For details pls. see Pin/Ball description of this pin.

NCVDDSB = This pin has a different functionality in an Production Device and an Emulation Device. For details pls. see Pin/Ball description of this pin.

Column “**X**” / “**Y**”:

Pad opening center coordinates

2.4.1 Pad Openings

Two different pad openings are used:

- 1) The default state of GPIOs (Px.y) during and after PORST active is controlled via HWCFG[6] (P14.4). HWCFG[6] has a weak internal pull-up active at start-up if the pin is left unconnected. See also User’s Manual, “Introduction Chapter”, “General Purpose I/O Ports and Peripheral I/O Lines”, Figure: “Default state of port pins during and after reset”.
- 2) If HWCFG[6] is left unconnected or is externally pulled high, weak internal pull-ups are active at GPIOs (Px.y) pins during and after reset. Exceptions are P33.8 (HighZ), P40.x (default configuration during and after reset: analog inputs, port input function disabled), ESR0, P21.6 / P21.7 (port pins overlaid with JTAG functionality).
- 3) If HWCFG[6] is connected to ground, port pins are predominantly in HighZ during and after reset. Exceptions are P33.8 (HighZ), P40.x (default configuration during and after reset: analog inputs, port input function disabled), ESR0, P21.6 / P21.7 (port pins overlaid with JTAG functionality).

- Standard Pad Opening is 70um x 75um where 70um is the width of the opening (width as seen from the die side) and 75um is the depth of the opening (from the die side into the silicon).
- Double Pad or Elephant Pad Opening is 130um x 75um where 130um is the width of the opening (width as seen from the die side) and 75um is the depth of the opening (from the die side into the silicon). Double Pads are used only for supply and can be identified by the words 'Double Pad' or 'Elephant Pad' in the Comment column.

2.4.2 Emergency Stop Function

The Emergency Stop function can be used to force GPIOs (General Purpose Inputs/Outputs) via an external input signal (EMGSTOPA or EMGSTOPB) into a defined state:

- Input state and
- PU or HighZ depending on HWCFG[6] level latched during Porst active

Control of the Emergency Stop function:

- The Emergency Stop function can be enabled/disabled in the SCU (see chapter "SCU", "Emergency Stop Control")
- The Emergency Stop input signal, EMGSTOPA (P33.8) / EMGSTOPB (P21.2), can be selected in the SCU (see chapter "SCU", "Emergency Stop Control")
- On port level, each GPIO can be enabled/disabled for the Emergency Stop function via the Px_ESR (Port x Emergency Stop) registers in the port control logic (see chapter "General Purpose I/O Ports and Peripheral I/O Lines", "Emergency Stop Register").

The Emergency Stop function is available for all GPIO Ports with the following exceptions:

- Not available for P20.2 (General Purpose Input/GPI only, overlaid with Testmode)
- Not available for P40.x (analog input ANx overlaid with GPI)
- Not available for P32.0 EVR13 SMPS mode.
- Not available for dedicated I/O without General Purpose Output function (e.g ESRx, TMS, TCK)

The Emergency Stop function can be overruled on the following GPIO Ports:

- P00.x and P02.x: Emergency Stop can be overruled by the 8-Bit Standby Controller (SBR), if implemented. Overruling can be disabled via the control registers P00_SCR / P02_SCR (see chapter "General Purpose I/O Ports and Peripheral I/O Lines", P00 / P01)
- P00.x: Emergency Stop can be overruled by the VADC. Overruling can be disabled via the control register P00_SCR (see chapter "General Purpose I/O Ports and Peripheral I/O Lines", P00)
- P14.0 and P14.1: Emergency Stop can be overruled in the DXCPL mode (DAP over can physical layer mode). No Overruling in the DXCM (Debug over can message) mode
- P21.6: Emergency Stop can be overruled in JTAG mode if this pin is used as TDI
- P21.7: Emergency Stop can be overruled in JTAG or Three Pin DAP mode
- P20.0: Emergency Stop can be overruled in JTAG mode if this GPIO is used as TDI
- P33.8: Emergency Stop can be overruled if this pin is used as safety output pin (SMUFSP)

2.4.3 Pull-Up/Pull-Down Reset Behavior of the Pins

Table 2-75 List of Pull-Up/Pull-Down Reset Behavior of the Pins

Pins	$\overline{\text{PORST}} = 0$	$\overline{\text{PORST}} = 1$
all GPIOs	Pull-up if HWCFG[6] = 1 or High-Z if HWCFG[6] = 0	
$\overline{\text{TDI}}$, $\overline{\text{TESTMODE}}$	Pull-up	
$\overline{\text{PORST}}^{1)}$	Pull-down with I_{PORST} relevant	Pull-down with I_{PDLI} relevant
$\overline{\text{TRST}}$, TCK, TMS	Pull-down	
$\overline{\text{ESR0}}$	The open-drain driver is used to drive low. ²⁾	Pull-up ³⁾
$\overline{\text{ESR1}}$	Pull-up ³⁾	
TDO	Pull-up	High-Z/Pull-up ⁴⁾

- 1) Pull-down with I_{PORST} relevant is always activated when a primary supply monitor detects a violation.
- 2) Valid additionally after deactivation of $\overline{\text{PORST}}$ until the internal reset phase has finished. See the SCU chapter for details.
- 3) See the SCU_IOCR register description.
- 4) Depends on JTAG/DAP selection with $\overline{\text{TRST}}$.

In case of leakage test ($\overline{\text{PORST}} = 0$ and $\overline{\text{TESTMODE}} = 0$), the pull-down of the $\overline{\text{TRST}}$ pin is switched off. In case of an user application ($\overline{\text{TESTMODE}} = 1$), the pull-down of the $\overline{\text{TRST}}$ is always switched on.

3 Electrical Specification

3.1 Parameter Interpretation

The parameters listed in this section partly represent the characteristics of the TC290 / TC297 / TC298 / TC299 and partly its requirements on the system. To aid interpreting the parameters easily when evaluating them for a design, they are marked with an two-letter abbreviation in column "Symbol":

- **CC**
Such parameters indicate **C**ontroller **C**haracteristics which are a distinctive feature of the TC290 / TC297 / TC298 / TC299 and must be regarded for a system design.
- **SR**
Such parameters indicate **S**ystem **R**equirements which must provided by the microcontroller system in which the TC290 / TC297 / TC298 / TC299 designed in.

3.2 Absolute Maximum Ratings

Stresses above the values listed under “Absolute Maximum Ratings” may cause permanent damage to the device. This is a stress rating only and functional operation of the device at these or any other conditions above those indicated in the Operational Conditions of this specification is not implied. Exposure to absolute maximum rating conditions may affect device reliability.

Table 3-1 Absolute Maximum Ratings

Parameter	Symbol	Values			Unit	Note / Test Condition
		Min.	Typ.	Max.		
Storage Temperature	T_{ST} SR	-65	-	170	°C	upto 65h @ $T_J = 150^\circ\text{C}$; upto 15h @ $T_J = 170^\circ\text{C}$
Voltage at V_{DD} power supply pins with respect to V_{SS} ¹⁾	V_{DD} SR	-	-	1.9	V	
Voltage at V_{DDP3} and V_{DDFL3} power supply pins with respect to V_{SS} ¹⁾	V_{DDP3} SR	-	-	4.43	V	
Voltage at V_{DDM} , V_{EXT} and V_{FLEX} power supply pins with respect to V_{SS} ¹⁾	V_{DDM} SR	-	-	7.0	V	
Voltage on any class A2 and LVDSH input pin with respect to V_{SS} ¹⁾²⁾	V_{IN} SR	-0.5	-	$\min(V_{DDP3} + 0.6, 4.23)$	V	Whatever is lower
Voltage on all other input pins with respect to V_{SS} ¹⁾²⁾	V_{IN} SR	-0.5	-	7.0	V	
Input current on any pin during overload condition ³⁾	I_{IN} SR	-10	-	10	mA	
Absolute maximum sum of all input circuit currents during overload condition ³⁾	ΣI_{IN} SR	-100	-	100	mA	

- 1) Valid for cumulated for up to 2.8h and pulse forms following a power supply switch on phase, where the rise and fall times are related to the system capacities and coils.
- 2) Voltages below V_{INmin} have no impact to the device reliability as long as the times and currents defined in section Pin Reliability in Overload for the affected pad(s) are not violated.
- 3) This parameter is an Absolute Maximum Rating. Exposure to Absolute Maximum Ratings for extended periods of time may damage the device.

3.3 Pin Reliability in Overload

When receiving signals from higher voltage devices, low-voltage devices experience overload currents and voltages that go beyond their own IO power supplies specification.

The following table defines overload conditions that will not cause any negative reliability impact if all the following conditions are met:

- full operation life-time (24500 h) is not exceeded
- **Operating Conditions** are met for
 - pad supply levels
 - temperature

If a pin current is out of the **Operating Conditions** but within the overload parameters, then the parameters functionality of this pin as stated in the Operating Conditions can no longer be guaranteed. Operation is still possible in most cases but with relaxed parameters.

Note: An overload condition on one or more pins does not require a reset.

Table 3-2 Overload Parameters

Parameter	Symbol	Values			Unit	Note / Test Condition
		Min.	Typ.	Max.		
Input current on any digital pin during overload condition	I_{IN}	-5	-	5	mA	except LVDS pins
		-15 ¹⁾	-	15 ¹⁾	mA	except LVDS pins; limited to max. 20 pulses with 1ms pulse length
Input current on LVDS pin during overload condition	I_{INLVDS}	-3	-	3	mA	
Absolute maximum sum of all input circuit currents during overload condition	I_{ING}	-50	-	50	mA	
Input current on analog input pin during overload condition	I_{INANA}	-3	-	3	mA	
		-5	-	5	mA	limited to 60h over lifetime
Absolute sum of all ADC inputs during overload condition	I_{INSCA}	-20	-	20	mA	
Absolute maximum sum of all input circuit currents during overload condition	ΣI_{INS}	-100	-	100	mA	
Signal voltage over/undershoot at GPIOs	V_{OUS}	$V_{SS} - 2$	-	$V_{EXT/FLEX} + 2$	V	limited to 60h over lifetime; Valid for LP, MP, MP+, and MPR pads
Inactive device pin current during overload condtion ²⁾	I_{ID}	-1	-	1	mA	All power supply voltages $V_{DDx} = 0$
Sum of all inactive device pin currents ²⁾	I_{IDS}	-100	-	100	mA	

Electrical Specification Pin Reliability in Overload

Table 3-2 Overload Parameters (cont'd)

Parameter	Symbol	Values			Unit	Note / Test Condition
		Min.	Typ.	Max.		
Overload coupling factor for digital inputs, negative ³⁾	$K_{\text{OVDN CC}}$	-	-	$4 \cdot 10^{-3}$		Overload injected on GPIO non LVDS pad and affecting neighbor A2 pads of P24.x and P25.x; $-2\text{mA} < I_{\text{IN}} < 0\text{mA}$
		-	$2 \cdot 10^{-4}$	-		Overload injected on GPIO non LVDS pad and affecting neighbor LP and A2 (except P24.x and P25.x) pads; $-2\text{mA} < I_{\text{IN}} < 0\text{mA}$
		-	-	$1 \cdot 10^{-2}$		Overload injected on GPIO non LVDS pad and affecting neighbor LP and A2 pads (except P25.2 and P25.4); $-5\text{mA} < I_{\text{IN}} < -2\text{mA}$
		-	-	$6 \cdot 10^{-4}$		Overload injected on GPIO non LVDS pad and affecting neighbor LP and A2 pads; $-2\text{mA} < I_{\text{IN}} < 0\text{mA}$
		-	-	$1.7 \cdot 10^{-3}$		Overload injected on GPIO non LVDS pad and affecting neighbor MP, MP+, and MPR pads; $-2\text{mA} < I_{\text{IN}} < 0\text{mA}$
		-	-	$2 \cdot 10^{-2}$		Overload injected on GPIO non LVDS pad and affecting neighbor MP, MP+, and MPR pads; $-5\text{mA} < I_{\text{IN}} < -2\text{mA}$
		-	-	$1.5 \cdot 10^{-2}$		Overload injected on GPIO non LVDS pad and affecting neighbor pads P25.2 and P25.4; $-5\text{mA} < I_{\text{IN}} < -2\text{mA}$
		-	-	0.3		Overload injected on LVDS pad and affecting neighbor LVDS pads
		-	-	0.93		coupling between pads 21.0, 21.1, 21.2 and 21.3
Data Sheet		3-3	19			V 1.1 2019-03

Electrical Specification Pin Reliability in Overload

Table 3-2 Overload Parameters (cont'd)

Parameter	Symbol	Values			Unit	Note / Test Condition
		Min.	Typ.	Max.		
Overload coupling factor for digital inputs, positive ³⁾	K_{OVDP} CC	-	-	$1 \cdot 10^{-5}$		Overload injected on GPIO non LVDS pad and affecting neighbor GPIO non LVDS pads
		-	-	$1.6 \cdot 10^{-4}$		Overload injected on GPIO pad and affecting neighbor P32.0 pad
		-	-	$1 \cdot 10^{-4}$		Overload injected on GPIO pad and affecting neighbor P32.4 and P33.12 pad
		-	-	$5 \cdot 10^{-4}$		Overload injected on LVDS pad and affecting neighbor LVDS pads
Overload coupling factor for analog inputs, negative	K_{OVAN} CC	-	-	$6 \cdot 10^{-4}$ ⁴⁾		Analog Inputs overlaid with class LP pads or pull down diagnostics; $-1\text{mA} < I_{IN} < 0\text{mA}$
		-	-	$1 \cdot 10^{-2}$		Analog Inputs overlaid with class LP pads or pull down diagnostics; $-5\text{mA} < I_{IN} < -1\text{mA}$
		-	-	$1 \cdot 10^{-4}$		else; $-5\text{mA} < I_{IN} < 0\text{mA}$
Overload coupling factor for analog inputs, positive	K_{OVAP} CC	-	-	$1 \cdot 10^{-5}$		$5\text{mA} < I_{IN} < 0\text{mA}$

- 1) Reduced VADC / DSADC result accuracy and / or GPIO input levels (V_{IL} and V_{IH}) can differ from specified parameters.
- 2) Limitations for time and supply levels specified in this section are not valid for this parameter.
- 3) Overload is measured as increase of pad leakage caused by injection on neighbor pad.
- 4) For analogue inputs overlaid with DSADC function the VCM holdbuffer shall be enabled, in case DSADCs are enabled.

Note: DSADC input pins count as analog pins as they are overlaid with VADC pins.

Table 3-3 PN-Junction Characteristics for positive Overload

Pad Type	$I_{IN} = 3 \text{ mA}$	$I_{IN} = 5 \text{ mA}$
F / A2	$U_{IN} = V_{DDP3} + 0.5 \text{ V}$	$U_{IN} = V_{DDP3} + 0.6 \text{ V}$
LP / MP / MP+	$U_{IN} = V_{EXT / FLEX} + 0.75 \text{ V}$	$U_{IN} = V_{EXT / FLEX} + 0.8 \text{ V}$
LVDSM	$U_{IN} = V_{EXT} + 0.75 \text{ V}$	-
LVDSH	$U_{IN} = V_{DDP3} + 0.5 \text{ V}$	-
D	$U_{IN} = V_{DDM} + 0.75 \text{ V}$	-

Table 3-4 PN-Junction Characteristics for negative Overload

Pad Type	$I_{IN} = -3 \text{ mA}$	$I_{IN} = -5 \text{ mA}$
F / A2	$U_{IN} = V_{SS} - 0.5 \text{ V}$	$U_{IN} = V_{SS} - 0.6 \text{ V}$
LP / MP / MP+	$U_{IN} = V_{SS} - 0.75 \text{ V}$	$U_{IN} = V_{SS} - 0.8 \text{ V}$
LVDSM	$U_{IN} = V_{SS} - 0.75 \text{ V}$	-
LVDSH	$U_{IN} = V_{SS} - 0.5 \text{ V}$	-
D	$U_{IN} = V_{SS} - 0.75 \text{ V}$	-

3.4 Operating Conditions

The following operating conditions must not be exceeded in order to ensure correct operation and reliability of the TC290 / TC297 / TC298 / TC299. All parameters specified in the following tables refer to these operating conditions, unless otherwise noticed.

Digital supply voltages applied to the TC290 / TC297 / TC298 / TC299 must be static regulated voltages.

All parameters specified in the following tables refer to these operating conditions (see table below), unless otherwise noticed in the Note / Test Condition column.

Table 3-5 Operating Conditions

Parameter	Symbol	Values			Unit	Note / Test Condition
		Min.	Typ.	Max.		
SRI frequency	f_{SRI} SR	-	-	270	MHz	$1.17V < V_{DD} < 1.43V$
		-	-	300 ¹⁾	MHz	$1.235V < V_{DD} < 1.43V$
Max System Frequency	f_{MAX} SR	-	-	270	MHz	$1.17V < V_{DD} < 1.43V$
		-	-	300 ¹⁾	MHz	$1.235V < V_{DD} < 1.43V$
CPU0 Frequency	f_{CPU0} SR	-	-	270	MHz	$1.17V < V_{DD} < 1.43V$
		-	-	300 ¹⁾	MHz	$1.235V < V_{DD} < 1.43V$
CPU1 Frequency	f_{CPU1} SR	-	-	270	MHz	$1.17V < V_{DD} < 1.43V$
		-	-	300 ¹⁾	MHz	$1.235V < V_{DD} < 1.43V$
CPU2 Frequency	f_{CPU2} SR	-	-	270	MHz	$1.17V < V_{DD} < 1.43V$
		-	-	300 ¹⁾	MHz	$1.235V < V_{DD} < 1.43V$
PLL output frequency	f_{PLL} SR	20	-	300	MHz	
PLL_ERAY output frequency	$f_{PLLERAY}$ SR	20	-	400	MHz	
SPB frequency	f_{SPB} SR	-	-	90	MHz	$1.17V < V_{DD} < 1.43V$
		-	-	100 ¹⁾	MHz	$1.235V < V_{DD} < 1.43V$
ASCLIN fast frequency	$f_{ASCLINF}$ SR	-	-	270	MHz	$1.17V < V_{DD} < 1.43V$
		-	-	300 ¹⁾	MHz	$1.235V < V_{DD} < 1.43V$
ASCLIN slow frequency	$f_{ASCLINS}$ SR	-	-	90	MHz	$1.17V < V_{DD} < 1.43V$
		-	-	100 ¹⁾	MHz	$1.235V < V_{DD} < 1.43V$
Baud2 frequency	f_{BAUD2} SR	-	-	270	MHz	$1.17V < V_{DD} < 1.43V$
		-	-	300 ¹⁾	MHz	$1.235V < V_{DD} < 1.43V$
Baud1 frequency	f_{BAUD1} SR	-	-	90	MHz	$1.17V < V_{DD} < 1.43V$
		-	-	100 ¹⁾	MHz	$1.235V < V_{DD} < 1.43V$
FSI2 frequency	f_{FSI2} SR	-	-	270	MHz	$1.17V < V_{DD} < 1.43V$
		-	-	300 ¹⁾	MHz	$1.235V < V_{DD} < 1.43V$
FSI frequency	f_{FSI} SR	-	-	90	MHz	$1.17V < V_{DD} < 1.43V$
		-	-	100 ¹⁾	MHz	$1.235V < V_{DD} < 1.43V$
GTM frequency	f_{GTM} SR	-	-	90	MHz	$1.17V < V_{DD} < 1.43V$
		-	-	100 ¹⁾	MHz	$1.235V < V_{DD} < 1.43V$
EBU frequency	f_{EBU} SR	-	-	180	MHz	$1.17V < V_{DD} < 1.43V$
		-	-	200	MHz	$1.235V < V_{DD} < 1.43V$

Electrical Specification Operating Conditions

Table 3-5 Operating Conditions (cont'd)

Parameter	Symbol	Values			Unit	Note / Test Condition
		Min.	Typ.	Max.		
STM frequency	f_{STM} SR	-	-	90	MHz	$1.17\text{V} < V_{\text{DD}} < 1.43\text{V}$
		-	-	100 ¹⁾	MHz	$1.235\text{V} < V_{\text{DD}} < 1.43\text{V}$
ERAY frequency	f_{ERAY} SR	-	-	80	MHz	
BBB frequency	f_{BBB} SR	-	-	150	MHz	
MultiCAN frequency	f_{CAN} SR	-	-	100	MHz	
Absolute sum of short circuit currents of the device	$\Sigma I_{\text{SC_D}}$ SR	-	-	100	mA	
Ambient Temperature	T_{A} SR	-40	-	125	°C	valid for all SAK products
		-40	-	150	°C	valid for all SAL products
		-40	-	170	°C	valid for all SAL products without package
Junction Temperature	T_{J} SR	-40	-	150	°C	valid for all SAK products
		-40	-	170	°C	valid for all SAL products
Core Supply Voltage ²⁾	V_{DD} SR	1.17	1.3	1.43 ³⁾	V	Only required if externally supplied
ADC analog supply voltage	V_{DDM} SR	2.97	5.0	5.5 ⁴⁾	V	
Digital external supply voltage for LP, MP, MP+ and LVDSM pads and EVR ⁵⁾	V_{EXT} SR	2.97	-	4.5	V	3.3V pad parameters are valid
		4.5	5.0	5.5 ⁴⁾	V	5V pad parameters are valid
Digital supply voltage for Flex port	V_{FLEX} SR	2.97	-	4.5	V	3.3V pad parameters are valid
		4.5	5.0	5.5 ⁴⁾	V	5V pad parameters are valid
Digital supply voltage for LVDSH and A2 pads ⁶⁾	V_{DDP3} SR	2.97	3.3	3.63 ⁷⁾	V	3.3V pad parameters are valid; only required if externally supplied
Flash supply voltage 3.3V ²⁾	V_{DDFL3} SR	2.97	3.3	3.63	V	Only required if externally supplied
Digital ground voltage	V_{SS} SR	0	-	-	V	
Analog ground voltage for V_{DDM}	V_{SSM} CC	-0.1	0	0.1	V	
Voltage to ensure defined pad states ⁸⁾	V_{DDPPA} CC	0.72	-	-	V	A2 and LVDSH
		1.4	-	-	V	LP, MP, MP+, MPR and LVDSM

Table 3-5 Operating Conditions (cont'd)

Parameter	Symbol	Values			Unit	Note / Test Condition
		Min.	Typ.	Max.		
Digital supply voltage for EBU	V_{EBU} SR	2.97	3.3	3.63	V	3.3V pad parameters are valid; only required if externally supplied
Digital external supply voltage for EVR and during Standby mode	V_{EVRSB} SR	2.97	-	5.5	V	
Digital supply voltage for EBU Flex port	V_{FLEXE} SR	2.97	3.3	4.5	V	3.3V pad parameters are valid
		4.5	5.0	5.5	V	5V pad parameters are valid

- 1) $V_{\text{DD}} = 1.33\text{V} \pm 7.5\%$ (with increased nominal V_{DD}) voltage by +2.5%.
- 2) No external inductive load permissible if EVR is used. All V_{DD} pins shall be connected together externally on the PCB.
- 3) Voltage overshoot to 1.69V is permissible, provided the duration is less than 2h cumulated. Reduced ADC accuracy and leakage is increased.
- 4) Voltage overshoot to 6.5V is permissible, provided the duration is less than 2h cumulated. Reduced ADC accuracy and leakage is increased.
- 5) All V_{EXT} pins shall be connected together externally on the PCB.
- 6) All V_{DDP3} pins shall be connected together externally on the PCB.
- 7) Voltage overshoot to 4.29V is permissible, provided the duration is less than 2h cumulated. Reduced ADC accuracy and leakage is increased.
- 8) This parameter is valid under the assumption the PORST signal is constantly at low level during the power-up/power-down of V_{DDP3} .

3.5 5 V / 3.3 V switchable Pads

Pad classes LP, MP and MP+ support both Automotive Level (AL) or TTL level (TTL) operation. Parameters are defined for AL operation and degrade in TTL operation.

Table 3-6 Standard_Pads

Parameter	Symbol	Values			Unit	Note / Test Condition
		Min.	Typ.	Max.		
Pin capacitance (digital inputs/outputs)	C_{IO} CC	-	6	10	pF	
Spike filter always blocked pulse duration	t_{SF1} CC	-	-	80	ns	PORST only
Spike filter pass-through pulse duration	t_{SF2} CC	220	-	-	ns	PORST only
PORST pad output current ¹⁾	I_{PORST} CC	11	-	-	mA	$V_{EXT} = 3.0V$; $V_{PORST} = 0.9V$; $T_J = 165^\circ C$
		13	-	-	mA	$V_{EXT} = 4.5V$; $V_{PORST} = 1.0V$

1) Pull-down with I_{PORST} relevant is always activated when a primary supply monitor detects a violation.

Table 3-7 Class LP 5V

Parameter	Symbol	Values			Unit	Note / Test Condition
		Min.	Typ.	Max.		
Input frequency	f_{IN} SR	-	-	75	MHz	Hysteresis active
		-	-	150	MHz	Hysteresis inactive
Input Hysteresis for LP pad ¹⁾	$HYSLP$ CC	0.09 * $V_{EXT/FLEX}$	-	-	V	AL
		0.075 * $V_{EXT/FLEX}$	-	-	V	TTL
Input Leakage current for LP pad	I_{OZLP} CC	-150	-	150	nA	$(0.1 * V_{EXT/FLEX}) < V_{IN} < (0.9 * V_{EXT/FLEX})$
		-350	-	350	nA	else
Input leakage current for P32.0	I_{OZP320} CC	-4900	-	4900	nA	$(0.1 * V_{EXT/FLEX}) < V_{IN} < (0.9 * V_{EXT/FLEX})$
		-9400	-	9400	nA	$(0.1 * V_{EXT/FLEX}) < V_{IN} < (0.9 * V_{EXT/FLEX})$; for $T_J > 150^\circ C$
		-5800	-	5800	nA	else
		-12000	-	12000	nA	else; for $T_J > 150^\circ C$
Pull-up current for LP pad	I_{PUHLP} CC	30	-	-	μA	V_{IHmin} ; AL
		43	-	-	μA	V_{IHmin} ; TTL
		-	-	107	μA	V_{ILmax} ; AL and TTL

Electrical Specification 5 V / 3.3 V switchable Pads

Table 3-7 Class LP 5V (cont'd)

Parameter	Symbol	Values			Unit	Note / Test Condition
		Min.	Typ.	Max.		
Pull-down current for LP pad	I_{PDLLP} CC	-	-	100	μA	V_{IHmin} ; AL and TTL
		46	-	-	μA	V_{ILmax} ; AL
		21	-	-	μA	V_{ILmax} ; TTL
On-Resistance for LP pad, weak driver ²⁾	$R_{DSONLPW}$ CC	200	620	1040	Ohm	PMOS/NMOS ; $I_{OH}=0.5\text{mA}$; $I_{OL}=0.5\text{mA}$
On-Resistance for LP pad, medium driver ²⁾	$R_{DSONLPM}$ CC	50	155	260	Ohm	PMOS/NMOS ; $I_{OH}=2\text{mA}$; $I_{OL}=2\text{mA}$
Rise / fall time for LP pad ³⁾	t_{LP} CC	-	-	$95+2.1 * C_L$	ns	$C_L \leq 50\text{pF}$; pin out driver=weak
		-	-	$200+2.9 * (C_L - 50)$	ns	$C_L \geq 50\text{pF}$; $C_L \leq 200\text{pF}$; pin out driver=weak
		-	-	$25+0.5 * C_L$	ns	$C_L \leq 50\text{pF}$; pin out driver=medium
		-	-	$50+0.75 * (C_L - 50)$	ns	$C_L \geq 50\text{pF}$; $C_L \leq 200\text{pF}$; pin out driver=medium
Input high voltage for LP pad	V_{IHLP} SR	$(0.73 * V_{EX} - 0.25)$ $T/FLEX$	-	-	V	Hysteresis active, AL
		2.03 ⁴⁾	-	-	V	Hysteresis active, TTL
Input low voltage for LP pad	V_{ILLP} SR	-	-	$(0.52 * V_{EX} - 0.25)$ $T/FLEX$	V	Hysteresis active, AL
		-	-	0.8 ⁵⁾	V	Hysteresis active, TTL
Input low / high voltage for LP pad	V_{ILHLP} CC	1.85	-	3.0	V	Hysteresis inactive; not available for P14.2, P14.4, P15.1, P15.10 and P15.11
Pad set-up time for LP pad	t_{SET_LP} CC	-	-	100	ns	
Input leakage current for P02.1	I_{OZ021} CC	-150	-	1030	nA	$(0.1 * V_{EXT/FLEX}) < V_{IN} < (0.9 * V_{EXT/FLEX})$; $T_J > 150^\circ\text{C}$
		-150	-	340	nA	$(0.1 * V_{EXT/FLEX}) < V_{IN} < (0.9 * V_{EXT/FLEX})$; $T_J = 150^\circ\text{C}$
		-420	-	1100	nA	else; $T_J > 150^\circ\text{C}$
		-350	-	380	nA	else; $T_J = 150^\circ\text{C}$
Pull down current for P32_0 pin	$I_{PDL P320}$ CC	-	-	105	μA	V_{IHmin} ; AL and TTL
		41	-	-	μA	V_{ILmax} ; AL
		16	-	-	μA	V_{ILmax} ; TTL

Table 3-7 Class LP 5V (cont'd)

Parameter	Symbol	Values			Unit	Note / Test Condition
		Min.	Typ.	Max.		
Pull Up Current for P32_0 pin	$I_{PUHP320}$ CC	25	-	-	μA	V_{IHmin} : AL
		38	-	-	μA	V_{IHmin} : TTL
		-	-	112	μA	V_{ILmax} : AL and TTL
Short Circuit current for LP pad 6)	I_{SC} SR	-10	-	10	mA	absolute max value (PSI5)
Deviation of symmetry for rising and falling edges	SYM CC	-	-	20	%	

- 1) Hysteresis is implemented to avoid metastable states and switching due to internal ground bounce. It can't be guaranteed that it suppresses switching due to external system noise.
- 2) For currents smaller than the $I_{OL/OH}$ from the test condition the defined Max. value stays unchanged.
- 3) Rise / fall times are defined 10% - 90% of $V_{EXT/FLEX}$.
- 4) $V_{IHx} = 0.27 * V_{EXT/FLEX} + 0.545\text{V}$
- 5) $V_{ILx} = 0.17 * V_{EXT/FLEX}$
- 6) The values are only valid if the pad is not used during operation, otherwise I_{SC} defines the limits for operation.

Table 3-8 Class LP 3.3V

Parameter	Symbol	Values			Unit	Note / Test Condition
		Min.	Typ.	Max.		
Input frequency	f_{IN} SR	-	-	50	MHz	Hysteresis active
		-	-	100	MHz	Hysteresis inactive
Input Hysteresis for LP pad ¹⁾	$HYSLP$ CC	0.05 * $V_{EXT/FLEX}$	-	-	V	AL and TTL
Input Leakage current for LP pad	I_{OZLP} CC	-150	-	150	nA	$(0.1 * V_{EXT/FLEX}) < V_{IN} < (0.9 * V_{EXT/FLEX})$
		-350	-	350	nA	else
Input leakage current for P32.0	I_{OZP320} CC	-4900	-	4900	nA	$(0.1 * V_{EXT/FLEX}) < V_{IN} < (0.9 * V_{EXT/FLEX})$
		-9400	-	9400	nA	$(0.1 * V_{EXT/FLEX}) < V_{IN} < (0.9 * V_{EXT/FLEX})$; for $T_J > 150\text{ }^\circ\text{C}$
		-5800	-	5900	nA	else
		-12000	-	12000	nA	else; for $T_J > 150\text{ }^\circ\text{C}$
Pull-up current for LP pad	I_{PUHLP} CC	17	-	-	μA	V_{IHmin} : AL
		19	-	-	μA	V_{IHmin} : TTL
		-	-	75	μA	V_{ILmax} : AL and TTL
Pull-down current for LP pad	I_{PDLLP} CC	-	-	75	μA	V_{IHmin} : AL and TTL
		22	-	-	μA	V_{ILmax} : AL
		11	-	-	μA	V_{ILmax} : TTL
On-Resistance for LP pad, weak driver ²⁾	$R_{DSONLPW}$ CC	250	875	1500	Ohm	; NMOS/PMOS ; $I_{OH}=0.25\text{mA}$; $I_{OL}=0.25\text{mA}$

Electrical Specification 5 V / 3.3 V switchable Pads
Table 3-8 Class LP 3.3V (cont'd)

Parameter	Symbol	Values			Unit	Note / Test Condition
		Min.	Typ.	Max.		
On-Resistance for LP pad, medium driver ²⁾	$R_{DSONLPM}$ CC	70	235	400	Ohm	; NMOS/PMOS ; $I_{OH}=1mA$; $I_{OL}=1mA$
Rise / fall time for LP pad ³⁾	t_{LP} CC	-	-	$150+3.4 * C_L$	ns	$C_L \leq 50pF$; pin out driver=weak
		-	-	$320+4.5 * (C_L - 50)$	ns	$C_L \geq 50pF$; $C_L \leq 200pF$; pin out driver=weak
		-	-	$30+0.8 * C_L$	ns	$C_L \leq 50pF$; pin out driver=medium
		-	-	$70+1.1 * (C_L - 50)$	ns	$C_L \geq 50pF$; $C_L \leq 200pF$; pin out driver=medium
Input high voltage for LP pad	V_{IHLP} SR	$(0.73 * V_{EX T/FLEX}) - 0.25$	-	-	V	Hysteresis active, AL
		1.6 ⁴⁾	-	-	V	Hysteresis active, TTL
Input low voltage for LP pad	V_{ILLP} SR	-	-	$(0.52 * V_{EX T/FLEX}) - 0.25$	V	Hysteresis active, AL
		-	-	0.5 ⁵⁾	V	Hysteresis active, TTL
Input low / high voltage for LP pad	V_{ILHLP} CC	1.1	-	1.9	V	Hysteresis inactive; not available for P14.2, P14.4, P15.1, P15.10 and P15.11
Pad set-up time for LP pad	t_{SET_LP} CC	-	-	100	ns	
Input leakage current for P02.1	I_{OZ021} CC	-150	-	920	nA	$(0.1 * V_{EXT/FLEX}) < V_{IN} < (0.9 * V_{EXT/FLEX})$; $T_J > 150^\circ C$
		-150	-	330	nA	$(0.1 * V_{EXT/FLEX}) < V_{IN} < (0.9 * V_{EXT/FLEX})$; $T_J = 150^\circ C$
		-360	-	1000	nA	else; $T_J > 150^\circ C$
		-350	-	375	nA	else; $T_J = 150^\circ C$
Pull down current for P32_0 pin	$I_{PDL P320}$ CC	-	-	80	μA	V_{IHmin} ; AL and TTL
		17	-	-	μA	V_{ILmax} ; AL
		6	-	-	μA	V_{ILmax} ; TTL
Pull Up Current for P32_0 pin	$I_{PUHP320}$ CC	12	-	-	μA	V_{IHmin} ; AL
		14	-	-	μA	V_{IHmin} ; TTL
		-	-	80	μA	V_{ILmax} ; AL and TTL
Short Circuit current for LP pad ⁶⁾	I_{SC} SR	-10	-	10	mA	absolute max value (PSI5)
Deviation of symmetry for rising and falling edges	SYM CC	-	-	20	%	

Electrical Specification 5 V / 3.3 V switchable Pads

- 1) Hysteresis is implemented to avoid metastable states and switching due to internal ground bounce. It can't be guaranteed that it suppresses switching due to external system noise.
- 2) For currents smaller than the $I_{OL/OH}$ from the test condition the defined Max. value stays unchanged.
- 3) Rise / fall times are defined 10% - 90% of $V_{EXT/FLEX}$.
- 4) $V_{IHx} = 0.27 * V_{EXT/FLEX} + 0.545V$
- 5) $V_{ILx} = 0.17 * V_{EXT/FLEX}$
- 6) The values are only valid if the pad is not used during operation, otherwise I_{SC} defines the limits for operation.

Table 3-9 Class MP 5V

Parameter	Symbol	Values			Unit	Note / Test Condition
		Min.	Typ.	Max.		
Input frequency	f_{IN} SR	-	-	75	MHz	Hysteresis active
		-	-	150	MHz	Hysteresis inactive
Input Hysteresis for MP pad ¹⁾	$HYSMP$ CC	0.09 * $V_{EXT/FLEX}$	-	-	V	AL
		0.075 * $V_{EXT/FLEX}$	-	-	V	TTL
Input Leakage current for MP pad	I_{OZMP} CC	-500	-	500	nA	$(0.1 * V_{EXT/FLEX}) < V_{IN} < (0.9 * V_{EXT/FLEX})$
		-1000	-	1000	nA	else
Pull-up current for MP pad	I_{PUHMP} CC	30	-	-	μA	V_{IHmin} ; AL
		43	-	-	μA	V_{IHmin} ; TTL
		-	-	107	μA	V_{ILmax} ; AL and TTL
Pull-down current for MP pad	I_{PDLMP} CC	-	-	100	μA	V_{IHmin} ; AL and TTL
		46	-	-	μA	V_{ILmax} ; AL
		21	-	-	μA	V_{ILmax} ; TTL
On-Resistance for MP pad, weak driver ²⁾	$R_{DSONMPW}$ CC	200	620	1040	Ohm	PMOS/NMOS ; $I_{OH}=0.5mA; I_{OL}=0.5mA$
On-Resistance for MP pad, medium driver ²⁾	$R_{DSONMPM}$ CC	50	155	260	Ohm	PMOS/NMOS ; $I_{OH}=2mA; I_{OL}=2mA$
On-Resistance for MP pad, strong driver ²⁾	$R_{DSONMPS}$ CC	20	75	130	Ohm	PMOS/NMOS ; $I_{OH}=8mA; I_{OL}=8mA$

Table 3-9 Class MP 5V (cont'd)

Parameter	Symbol	Values			Unit	Note / Test Condition
		Min.	Typ.	Max.		
Rise / fall time for MP pad ³⁾	$t_{MP\ CC}$	-	-	$95+2.1 \cdot C_L$	ns	$C_L \leq 50\text{pF}$; pin out driver=weak
		-	-	$200+2.9 \cdot (C_L-50)$	ns	$C_L \geq 50\text{pF}$; $C_L \leq 200\text{pF}$; pin out driver=weak
		-	-	$25+0.5 \cdot C_L$	ns	$C_L \leq 50\text{pF}$; pin out driver=medium
		-	-	$50 + 0.75 \cdot (C_L - 50)$	ns	$C_L \geq 50\text{pF}$; $C_L \leq 200\text{pF}$; pin out driver=medium
		-	-	$17.5+0.25 \cdot C_L$	ns	$C_L \leq 50\text{pF}$; edge=medium ; pin out driver=strong
		-	-	$30+0.3 \cdot (C_L-50)$	ns	$C_L \geq 50\text{pF}$; $C_L \leq 200\text{pF}$; edge=medium ; pin out driver=strong
		-	-	$7+0.2 \cdot C_L$	ns	$C_L \leq 50\text{pF}$; edge=sharp ; pin out driver=strong
		-	-	$17+0.3 \cdot (C_L-50)$	ns	$C_L \geq 50\text{pF}$; $C_L \leq 200\text{pF}$; edge=sharp ; pin out driver=strong
Input high voltage for MP pad	$V_{IHMP\ SR}$	$(0.73 \cdot V_{EXT/FLEX}) - 0.25$	-	-	V	Hysteresis active, AL
		2.03 ⁴⁾	-	-	V	Hysteresis active, TTL
Input low voltage for MP pad	$V_{ILMP\ SR}$	-	-	$(0.52 \cdot V_{EXT/FLEX}) - 0.25$	V	Hysteresis active, AL
		-	-	0.8 ⁵⁾	V	Hysteresis active, TTL
Input low / high voltage for MP pad	$V_{ILHMP\ CC}$	1.85	-	3.0	V	Hysteresis inactive
Pad set-up time for MP pad	$t_{SET_MP\ CC}$	-	-	100	ns	
Short Circuit current for MP pad ⁶⁾	$I_{SC\ SR}$	-10	-	10	mA	absolute max value (PSI5)
Deviation of symmetry for rising and falling edges	$SYM\ CC$	-	-	20	%	

1) Hysteresis is implemented to avoid metastable states and switching due to internal ground bounce. It can't be guaranteed that it suppresses switching due to external system noise.

2) For currents smaller than the $I_{OL/OH}$ from the test condition the defined Max. value stays unchanged.

3) Rise / fall times are defined 10% - 90% of $V_{EXT/FLEX}$.

4) $V_{IHx} = 0.27 \cdot V_{EXT/FLEX} + 0.545\text{V}$

5) $V_{ILx} = 0.17 \cdot V_{EXT/FLEX}$

6) The values are only valid if the pad is not used during operation, otherwise I_{SC} defines the limits for operation.

Table 3-10 Class MP 3.3V

Parameter	Symbol	Values			Unit	Note / Test Condition
		Min.	Typ.	Max.		
Input frequency	f_{IN} SR	-	-	50	MHz	Hysteresis active
		-	-	100	MHz	Hysteresis inactive
Input Hysteresis for MP pad ¹⁾	$HYSMP$ CC	0.05 * $V_{EXT/FLEX}$	-	-	V	AL and TTL
Input Leakage current for MP pad	I_{OZMP} CC	-500	-	500	nA	$(0.1 * V_{EXT/FLEX}) < V_{IN} < (0.9 * V_{EXT/FLEX})$
		-1000	-	1000	nA	else
Pull-up current for MP pad	I_{PUHMP} CC	17	-	-	μA	V_{IHmin} ; AL
		19	-	-	μA	V_{IHmin} ; TTL
		-	-	75	μA	V_{ILmax} ; AL and TTL
Pull-down current for MP pad	I_{PDLMP} CC	-	-	75	μA	V_{IHmin} ; AL and TTL
		22	-	-	μA	V_{ILmax} ; AL
		11	-	-	μA	V_{ILmax} ; TTL
On-Resistance for MP pad, weak driver ²⁾	$R_{DSONMPW}$ CC	250	875	1500	Ohm	; NMOS/PMOS ; $I_{OH}=0.25mA$; $I_{OL}=0.25mA$
On-Resistance for MP pad, medium driver ²⁾	$R_{DSONMPM}$ CC	70	235	400	Ohm	; NMOS/PMOS ; $I_{OH}=1mA$; $I_{OL}=1mA$
On-Resistance for MP pad, strong driver ²⁾	$R_{DSONMPS}$ CC	20	110	200	Ohm	PMOS/NMOS ; $I_{OH}=4mA$; $I_{OL}=4mA$
Rise / fall time for MP pad ³⁾	t_{MP} CC	-	-	$150+3.4 * C_L$	ns	$C_L \leq 50pF$; pin out driver=weak
		-	-	$320+4.5 * (C_L-50)$	ns	$C_L \geq 50pF$; $C_L \leq 200pF$; pin out driver=weak
		-	-	$30+0.8 * C_L$	ns	$C_L \leq 50pF$; pin out driver=medium
		-	-	$70+1.1 * (C_L-50)$	ns	$C_L \geq 50pF$; $C_L \leq 200pF$; pin out driver=medium
		-	-	$32.5+0.35 * C_L$	ns	$C_L \leq 50pF$; edge=medium ; pin out driver=strong
		-	-	$50+0.45 * (C_L-50)$	ns	$C_L \geq 50pF$; $C_L \leq 200pF$; edge=medium ; pin out driver=strong
		-	-	$14.5+0.35 * C_L$	ns	$C_L \leq 50pF$; edge=sharp ; pin out driver=strong
		-	-	$32+0.5 * (C_L-50)$	ns	$C_L \geq 50pF$; $C_L \leq 200pF$; edge=sharp ; pin out driver=strong

Electrical Specification 5 V / 3.3 V switchable Pads
Table 3-10 Class MP 3.3V (cont'd)

Parameter	Symbol	Values			Unit	Note / Test Condition
		Min.	Typ.	Max.		
Input high voltage for MP pad	V_{IHMP} SR	$(0.73 \cdot V_{EX})^{T/FLEX} - 0.25$	-	-	V	Hysteresis active, AL
		1.6 ⁴⁾	-	-	V	Hysteresis active, TTL
Input low voltage for MP pad	V_{ILMP} SR	-	-	$(0.52 \cdot V_{EX})^{T/FLEX} - 0.25$	V	Hysteresis active, AL
		-	-	0.5 ⁵⁾	V	Hysteresis active, TTL
Input low / high voltage for MP pad	V_{ILHMP} CC	1.1	-	1.9	V	Hysteresis inactive
Pad set-up time for MP pad	t_{SET_MP} CC	-	-	100	ns	
Short Circuit current for MP pad ⁶⁾	I_{SC} SR	-10	-	10	mA	absolute max value (PSI5)
Deviation of symmetry for rising and falling edges	SYM CC	-	-	20	%	

- 1) Hysteresis is implemented to avoid metastable states and switching due to internal ground bounce. It can't be guaranteed that it suppresses switching due to external system noise.
- 2) For currents smaller than the $I_{OL/OH}$ from the test condition the defined Max. value stays unchanged.
- 3) Rise / fall times are defined 10% - 90% of $V_{EXT/FLEX}$.
- 4) $V_{IHx} = 0.27 \cdot V_{EXT/FLEX} + 0.545V$
- 5) $V_{ILx} = 0.17 \cdot V_{EXT/FLEX}$
- 6) The values are only valid if the pad is not used during operation, otherwise I_{SC} defines the limits for operation.

Table 3-11 Class MP+ 5V

Parameter	Symbol	Values			Unit	Note / Test Condition
		Min.	Typ.	Max.		
Input frequency	f_{IN} SR	-	-	75	MHz	Hysteresis active
		-	-	150	MHz	Hysteresis inactive
Input hysteresis for MP+ pad ¹⁾	$HYSMPP$ CC	$0.09 \cdot V_{EXT/FLEX}$	-	-	V	AL
		$0.075 \cdot V_{EXT/FLEX}$	-	-	V	TTL
Input leakage current for MP+ pad	I_{OZMPP} CC	-750	-	750	nA	$(0.1 \cdot V_{EXT/FLEX}) < V_{IN} < (0.9 \cdot V_{EXT/FLEX})$
		-1500	-	1500	nA	else
Pull-up current for MP+ pad	I_{PUHMPP} CC	30	-	-	μA	V_{IHmin} ; AL
		43	-	-	μA	V_{IHmin} ; TTL
		-	-	107	μA	V_{ILmax} ; AL and TTL
Pull-down current for MP+ pad	I_{PDLMP} CC	-	-	100	μA	V_{IHmin} ; AL and TTL
		46	-	-	μA	V_{ILmax} ; AL
		21	-	-	μA	V_{ILmax} ; TTL

Electrical Specification 5 V / 3.3 V switchable Pads

Table 3-11 Class MP+ 5V (cont'd)

Parameter	Symbol	Values			Unit	Note / Test Condition
		Min.	Typ.	Max.		
On-resistance for MP+ pad, weak driver ²⁾	$R_{DSONMPPW}$ CC	200	620	1040	Ohm	PMOS/NMOS ; $I_{OH}=0.5mA$; $I_{OL}=0.5mA$
On-resistance for MP+ pad, medium driver ²⁾	$R_{DSONMPPM}$ CC	50	155	260	Ohm	PMOS/NMOS ; $I_{OH}=2mA$; $I_{OL}=2mA$
On-resistance for MP+ pad, strong driver ²⁾	$R_{DSONMPPS}$ CC	20	55	90	Ohm	PMOS/NMOS ; $I_{OH}=8mA$; $I_{OL}=8mA$
Rise/fall time for MP+ pad ³⁾	t_{MPP} CC	-	-	$95+2.1 \cdot C_L$	ns	$C_L \leq 50pF$; pin out driver=weak
		-	-	$200+2.9 \cdot (C_L-50)$	ns	$C_L \geq 50pF$; $C_L \leq 200pF$; pin out driver=weak
		-	-	$25+0.5 \cdot C_L$	ns	$C_L \leq 50pF$; pin out driver=medium
		-	-	$50+0.75 \cdot (C_L-50)$	ns	$C_L \geq 50pF$; $C_L \leq 200pF$; pin out driver=medium
		-	-	$9+0.16 \cdot C_L$	ns	$C_L \leq 50pF$; edge=medium ; pin out driver=strong
		-	-	$17+0.2 \cdot (C_L-50)$	ns	$C_L \geq 50pF$; $C_L \leq 200pF$; edge=medium ; pin out driver=strong
		-	-	$4+0.16 \cdot C_L$	ns	$C_L \leq 50pF$; edge=sharp ; pin out driver=strong
		-	-	$12+0.21 \cdot (C_L-50)$	ns	$C_L \geq 50pF$; $C_L \leq 200pF$; edge=sharp ; pin out driver=strong
		-	-	5	ns	from 0.8V to 2.0V (RMII) ; $C_L=25pF$; edge=sharp ; pin out driver=strong
		-	-	4.5	ns	$C_L=15pF$; edge=sharp ; pin out driver=strong
Input high voltage for MP+ pad	V_{IHMP} SR	$(0.73 \cdot V_{EX} - 0.25)$ $T/FLEX)$	-	-	V	Hysteresis active, AL
		2.03 ⁴⁾	-	-	V	Hysteresis active, TTL
Input low voltage for MP+ pad	V_{ILMP} SR	-	-	$(0.52 \cdot V_{EX} - 0.25)$ $T/FLEX)$	V	Hysteresis active, AL
		-	-	0.8 ⁵⁾	V	Hysteresis active, TTL
Input low / high voltage for MP+ pad	V_{ILHMP} CC	1.85	-	3.0	V	Hysteresis inactive
Pad set-up time for MP+ pad	t_{SET_MPP} CC	-	-	100	ns	

Electrical Specification 5 V / 3.3 V switchable Pads
Table 3-11 Class MP+ 5V (cont'd)

Parameter	Symbol	Values			Unit	Note / Test Condition
		Min.	Typ.	Max.		
Short circuit current for MP+ pad ⁶⁾	I_{SCMPP} SR	-10	-	10	mA	absolute max value (PSI5)
Deviation of symmetry for rising and falling edges	SYM CC	-	-	20	%	

- 1) Hysteresis is implemented to avoid metastable states and switching due to internal ground bounce. It can't be guaranteed that it suppresses switching due to external system noise.
- 2) For currents smaller than the $I_{OL/OH}$ from the test condition the defined Max. value stays unchanged.
- 3) Rise / fall times are defined 10% - 90% of $V_{EXT/FLEX}$.
- 4) $V_{IHx} = 0.27 * V_{EXT/FLEX} + 0.545V$
- 5) $V_{ILx} = 0.17 * V_{EXT/FLEX}$
- 6) The values are only valid if the pad is not used during operation, otherwise I_{SC} defines the limits for operation.

Table 3-12 Class MP+ 3.3V

Parameter	Symbol	Values			Unit	Note / Test Condition
		Min.	Typ.	Max.		
Input frequency	f_{IN} SR	-	-	50	MHz	Hysteresis active
		-	-	100	MHz	Hysteresis inactive
Input hysteresis for MP+ pad ¹⁾	$HYSMPP$ CC	0.05 * $V_{EXT/FLEX}$	-	-	V	AL and TTL
Input leakage current for MP+ pad	I_{OZMPP} CC	-750	-	750	nA	$(0.1 * V_{EXT/FLEX}) < V_{IN} < (0.9 * V_{EXT/FLEX})$
		-1500	-	1500	nA	else
Pull-up current for MP+ pad	I_{PUHMPP} CC	17	-	-	μA	V_{IHmin} ; AL
		19	-	-	μA	V_{IHmin} ; TTL
		-	-	75	μA	V_{ILmax} ; AL and TTL
Pull-down current for MP+ pad	I_{PDLMPP} CC	-	-	75	μA	V_{IHmin} ; AL and TTL
		22	-	-	μA	V_{ILmax} ; AL
		11	-	-	μA	V_{ILmax} ; TTL
On-resistance for MP+ pad, weak driver ²⁾	$R_{DSONMPPW}$ CC	250	875	1500	Ohm	; NMOS/PMOS ; $I_{OH}=0.25mA$; $I_{OL}=0.25mA$
On-resistance for MP+ pad, medium driver ²⁾	$R_{DSONMPPM}$ CC	70	235	400	Ohm	; NMOS/PMOS ; $I_{OH}=1mA$; $I_{OL}=1mA$
On-resistance for MP+ pad, strong driver ²⁾	$R_{DSONMPPS}$ CC	20	75	130	Ohm	PMOS/NMOS ; $I_{OH}=4mA$; $I_{OL}=4mA$

Table 3-12 Class MP+ 3.3V (cont'd)

Parameter	Symbol	Values			Unit	Note / Test Condition
		Min.	Typ.	Max.		
Rise/fall time for MP+ pad ³⁾	$t_{MPP\ CC}$	-	-	150+3.4* C_L	ns	$C_L \leq 50\text{pF}$; pin out driver=weak
		-	-	320+4.5*(C_L-50)	ns	$C_L \geq 50\text{pF}$; $C_L \leq 200\text{pF}$; pin out driver=weak
		-	-	30+0.8* C_L	ns	$C_L \leq 50\text{pF}$; pin out driver=medium
		-	-	70+1.1*(C_L-50)	ns	$C_L \geq 50\text{pF}$; $C_L \leq 200\text{pF}$; pin out driver=medium
		-	-	20+0.2* C_L	ns	$C_L \leq 50\text{pF}$; edge=medium ; pin out driver=strong
		-	-	30+0.3*(C_L-50)	ns	$C_L \geq 50\text{pF}$; $C_L \leq 200\text{pF}$; edge=medium ; pin out driver=strong
		-	-	13+0.2* C_L	ns	$C_L \leq 50\text{pF}$; edge=sharp ; pin out driver=strong
		-	-	7.65	ns	$C_L = 15\text{pF}$; $V_{EXT/FLEX} = 3.135\text{V}$; $V = 0\text{V}$ to 2.0V; edge=sharp ; pin out driver=strong
		-	-	5.42	ns	$C_L = 15\text{pF}$; $V_{EXT/FLEX} = 3.135\text{V}$; $V = 3.135\text{V}$ to 0.8V; edge=sharp ; pin out driver=strong
		-	-	7.36	ns	$C_L = 15\text{pF}$; $V_{EXT/FLEX} = 3.201\text{V}$; $V = 0\text{V}$ to 2.0V; edge=sharp ; pin out driver=strong
		-	-	5.32	ns	$C_L = 15\text{pF}$; $V_{EXT/FLEX} = 3.201\text{V}$; $V = 3.201\text{V}$ to 0.8V; edge=sharp ; pin out driver=strong
		-	-	5.9	ns	$C_L = 15\text{pF}$; $V_{EXT/FLEX} = 3.63\text{V}$; $V = 0\text{V}$ to 2.0V; edge=sharp ; pin out driver=strong
		-	-	4.8	ns	$C_L = 15\text{pF}$; $V_{EXT/FLEX} = 3.63\text{V}$; $V = 3.63\text{V}$ to 0.8V; edge=sharp ; pin out driver=strong
		-	-	23+0.3*(C_L-50)	ns	$C_L \geq 50\text{pF}$; $C_L \leq 200\text{pF}$; edge=sharp ; pin out driver=strong
		-	-	5	ns	from 0.8V to 2.0V (RMII) ; $C_L=25\text{pF}$; edge=sharp ; pin out driver=strong
-	-	4.5	ns	from 0.2 * $V_{EXT/FLEX}$ to		

Electrical Specification 5 V / 3.3 V switchable Pads
Table 3-12 Class MP+ 3.3V (cont'd)

Parameter	Symbol	Values			Unit	Note / Test Condition
		Min.	Typ.	Max.		
Input high voltage for MP+ pad	V_{IHMP+} SR	$(0.73 \cdot V_{EX})^{T/FLEX} - 0.25$	-	-	V	Hysteresis active, AL
		1.6 ⁴⁾	-	-	V	Hysteresis active, TTL
Input low voltage for MP+ pad	V_{ILMP+} SR	-	-	$(0.52 \cdot V_{EX})^{T/FLEX} - 0.25$	V	Hysteresis active, AL
		-	-	0.5 ⁵⁾	V	Hysteresis active, TTL
Input low / high voltage for MP+ pad	V_{ILHMP+} CC	1.1	-	1.9	V	Hysteresis inactive
Pad set-up time for MP+ pad	t_{SET_MPP} CC	-	-	100	ns	
Short circuit current for MP+ pad ⁶⁾	I_{SCMP+} SR	-10	-	10	mA	absolute max value (PSI5)
Deviation of symmetry for rising and falling edges	SYM CC	-	-	20	%	

- 1) Hysteresis is implemented to avoid metastable states and switching due to internal ground bounce. It can't be guaranteed that it suppresses switching due to external system noise.
- 2) For currents smaller than the $I_{OL/OH}$ from the test condition the defined Max. value stays unchanged.
- 3) Rise / fall times are defined 10% - 90% of $V_{EXT/FLEX}$.
- 4) $V_{IHx} = 0.27 \cdot V_{EXT/FLEX} + 0.545V$
- 5) $V_{ILx} = 0.17 \cdot V_{EXT/FLEX}$
- 6) The values are only valid if the pad is not used during operation, otherwise I_{SC} defines the limits for operation.

Table 3-13 Class MPR 5V

Parameter	Symbol	Values			Unit	Note / Test Condition
		Min.	Typ.	Max.		
Input frequency	f_{IN} SR	-	-	75	MHz	Hysteresis active
		-	-	150	MHz	Hysteresis inactive
Input Hysteresis for MPR pads ¹⁾	$HYSMPR$ CC	$0.09 \cdot V_{EXT/FLEX}$	-	-	V	AL
		$0.075 \cdot V_{EXT/FLEX}$	-	-	V	TTL
Input leakage current class MPR	I_{OZMPR} CC	-750	-	750	nA	$(0.1 \cdot V_{EXT/FLEX}) < V_{IN} < (0.9 \cdot V_{EXT/FLEX})$
		-1500	-	1500	nA	else
Pull-up current	I_{PUHMPR} CC	30	-	-	μA	V_{IHmin} ; AL
		43	-	-	μA	V_{IHmin} ; TTL
		-	-	107	μA	V_{ILmax} ; AL and TTL
Pull-down current	I_{PDLMPR} CC	-	-	100	μA	V_{IHmin} ; AL and TTL
		46	-	-	μA	V_{ILmax} ; AL
		21	-	-	μA	V_{ILmax} ; TTL

Electrical Specification 5 V / 3.3 V switchable Pads

Table 3-13 Class MPR 5V (cont'd)

Parameter	Symbol	Values			Unit	Note / Test Condition
		Min.	Typ.	Max.		
On-resistance of the MPR pad, weak driver ²⁾	$R_{DSONMPRW}$ CC	200	620	1040	Ohm	PMOS/NMOS ; $I_{OH}=0.5mA$; $I_{OL}=0.5mA$
On-resistance of the MPR pad, medium driver ²⁾	$R_{DSONMPRM}$ CC	50	155	260	Ohm	PMOS/NMOS ; $I_{OH}=2mA$; $I_{OL}=2mA$
On-resistance of the MPR pad, strong driver ²⁾	$R_{DSONMPRS}$ CC	20	55	90	Ohm	PMOS/NMOS ; $I_{OH}=8mA$; $I_{OL}=8mA$
Rise/fall time ³⁾	t_{MPR} CC	-	-	$95+2.1 \cdot C_L$	ns	$C_L \leq 50pF$; pin out driver=weak
		-	-	$200+2.9 \cdot (C_L-50)$	ns	$C_L \geq 50pF$; $C_L \leq 200pF$; pin out driver=weak
		-	-	$25+0.5 \cdot C_L$	ns	$C_L \leq 50pF$; pin out driver=medium
		-	-	$50+0.75 \cdot (C_L-50)$	ns	$C_L \geq 50pF$; $C_L \leq 200pF$; pin out driver=medium
		-	-	$9+0.16 \cdot C_L$	ns	$C_L \geq 0pF$; $C_L \leq 50pF$; edge=medium ; pin out driver=strong
		-	-	$17+0.2 \cdot (C_L-50)$	ns	$C_L \geq 50pF$; $C_L \leq 200pF$; edge=medium ; pin out driver=strong
		-	-	$4+0.16 \cdot C_L$	ns	$C_L \leq 50pF$; edge=sharp ; pin out driver=strong
		-	-	$12+0.21 \cdot (C_L-50)$	ns	$C_L \geq 50pF$; $C_L \leq 200pF$; edge=sharp ; pin out driver=strong
		-	-	5	ns	from 0.8V to 2.0V (RMII) ; $C_L=25pF$; edge=sharp ; pin out driver=strong
		-	-	4.5	ns	from $0.2 \cdot V_{EXT/FLEX}$ to $0.8 \cdot V_{EXT/FLEX}$; $C_L=15pF$; edge=sharp ; pin out driver=strong
Input high voltage, class MPR pads	V_{IHMPR} SR	$(0.73 \cdot V_{EXT/FLEX}) - 0.25$	-	-	V	Hysteresis active, AL
		2.03 ⁴⁾	-	-	V	Hysteresis active, TTL
Input low voltage, class MPR pads	V_{ILMPR} SR	-	-	$(0.52 \cdot V_{EXT/FLEX}) - 0.25$	V	Hysteresis active, AL
		-	-	0.8 ⁵⁾	V	Hysteresis active, TTL
Input low / high voltage, class MPR pads	V_{ILHMPR} SR	1.2	-	2.3	V	Hysteresis inactive

Electrical Specification 5 V / 3.3 V switchable Pads

Table 3-13 Class MPR 5V (cont'd)

Parameter	Symbol	Values			Unit	Note / Test Condition
		Min.	Typ.	Max.		
Pad set-up time	t_{SET_MPR} CC	-	-	100	ns	
Short circuit current Class MPR	I_{SC} SR	-10	-	10	mA	absolute max value (PSI5)
Deviation of symmetry for rising and falling edges	SYM CC	-	-	20	%	

- 1) Hysteresis is implemented to avoid metastable states and switching due to internal ground bounce. It can't be guaranteed that it suppresses switching due to external system noise.
- 2) For currents smaller than the $I_{OL/OH}$ from the test condition the defined Max. value stays unchanged.
- 3) Rise / fall times are defined 10% - 90% of $V_{EXT/FLEX}$.
- 4) $V_{IHx} = 0.27 * V_{EXT/FLEX} + 0.545V$
- 5) $V_{ILx} = 0.17 * V_{EXT/FLEX}$

Table 3-14 Class MPR 3.3V

Parameter	Symbol	Values			Unit	Note / Test Condition
		Min.	Typ.	Max.		
Input frequency	f_{IN} SR	-	-	50	MHz	Hysteresis active
		-	-	100	MHz	Hysteresis inactive
Input Hysteresis for MPR pads ¹⁾	$HYSMPR$ CC	$0.05 * V_{EXT/FLEX}$	-	-	V	AL and TTL
Input leakage current class MPR	I_{OZMPR} CC	-750	-	750	nA	$(0.1 * V_{EXT/FLEX}) < V_{IN} < (0.9 * V_{EXT/FLEX})$
		-1500	-	1500	nA	else
Pull-up current	I_{PUHMPR} CC	17	-	-	μA	V_{IHmin} ; AL
		19	-	-	μA	V_{IHmin} ; TTL
		-	-	75	μA	V_{ILmax} ; AL and TTL
Pull-down current	I_{PDLMPR} CC	-	-	75	μA	V_{IHmin} ; AL and TTL
		22	-	-	μA	V_{ILmax} ; AL
		11	-	-	μA	V_{ILmax} ; TTL
On-resistance of the MPR pad, weak driver ²⁾	$R_{DSONMPRW}$ CC	250	875	1500	Ohm	; NMOS/PMOS ; $I_{OH}=0.25mA$; $I_{OL}=0.25mA$
On-resistance of the MPR pad, medium driver ²⁾	$R_{DSONMPRM}$ CC	70	235	400	Ohm	; NMOS/PMOS ; $I_{OH}=1mA$; $I_{OL}=1mA$
On-resistance of the MPR pad, strong driver ²⁾	$R_{DSONMPRS}$ CC	20	75	130	Ohm	PMOS/NMOS ; $I_{OH}=4mA$; $I_{OL}=4mA$

Table 3-14 Class MPR 3.3V (cont'd)

Parameter	Symbol	Values			Unit	Note / Test Condition
		Min.	Typ.	Max.		
Rise/fall time ³⁾	$t_{MPR\ CC}$	-	-	$150+3.4 \cdot C_L$	ns	$C_L \leq 50\text{pF}$; pin out driver=weak
		-	-	$320+4.5 \cdot (C_L-50)$	ns	$C_L \geq 50\text{pF}$; $C_L \leq 200\text{pF}$; pin out driver=weak
		-	-	$30+0.8 \cdot C_L$	ns	$C_L \leq 50\text{pF}$; pin out driver=medium
		-	-	$70+1.1 \cdot (C_L-50)$	ns	$C_L \geq 50\text{pF}$; $C_L \leq 200\text{pF}$; pin out driver=medium
		-	-	$20+0.2 \cdot C_L$	ns	$C_L \geq 0\text{pF}$; $C_L \leq 50\text{pF}$; edge=medium; pin out driver=strong
		-	-	$30+0.3 \cdot (C_L-50)$	ns	$C_L \geq 50\text{pF}$; $C_L \leq 200\text{pF}$; edge=medium; pin out driver=strong
		-	-	$13+0.2 \cdot C_L$	ns	$C_L \leq 50\text{pF}$; edge=sharp; pin out driver=strong
		-	-	$23+0.3 \cdot (C_L-50)$	ns	$C_L \geq 50\text{pF}$; $C_L \leq 200\text{pF}$; edge=sharp; pin out driver=strong
		-	-	5	ns	from 0.8V to 2.0V (RMII); $C_L=25\text{pF}$; edge=sharp; pin out driver=strong
		-	-	4.5	ns	from $0.2 \cdot V_{EXT/FLEX}$ to $0.8 \cdot V_{EXT/FLEX}$; $C_L=15\text{pF}$; edge=sharp; pin out driver=strong
Input high voltage, class MPR pads	$V_{IHMPR\ SR}$	$(0.73 \cdot V_{EX\ T/FLEX}) - 0.25$	-	-	V	Hysteresis active, AL
		1.6 ⁴⁾	-	-	V	Hysteresis active, TTL
Input low voltage, class MPR pads	$V_{ILMPR\ SR}$	-	-	$(0.52 \cdot V_{EX\ T/FLEX}) - 0.25$	V	Hysteresis active, AL
		-	-	0.5 ⁵⁾	V	Hysteresis active, TTL
Input low / high voltage, class MPR pads	$V_{ILHMPR\ SR}$	0.8	-	1.7	V	Hysteresis inactive
Pad set-up time	$t_{SET_MPR\ CC}$	-	-	100	ns	
Short circuit current Class MPR	$I_{SC\ SR}$	-10	-	10	mA	absolute max value (PSI5)

1) Hysteresis is implemented to avoid metastable states and switching due to internal ground bounce. It can't be guaranteed that it suppresses switching due to external system noise.

2) For currents smaller than the $I_{OL/OH}$ from the test condition the defined Max. value stays unchanged.

Electrical Specification 5 V / 3.3 V switchable Pads

- 3) Rise / fall times are defined 10% - 90% of $V_{EXT/FLEX}$.
- 4) $V_{IHx} = 0.27 * V_{EXT/FLEX} + 0.545V$
- 5) $V_{ILx} = 0.17 * V_{EXT/FLEX}$

Table 3-15 Class S

Parameter	Symbol	Values			Unit	Note / Test Condition
		Min.	Typ.	Max.		
Input frequency	f_{IN} SR	-	-	75	MHz	Hysteresis active
		-	-	150	MHz	Hysteresis inactive
Input Hysteresis for S pad ¹⁾	HYS_S CC	0.3	-	-	V	
Pull-up current for S pad	I_{PUHS} CC	30	-	-	μA	V_{IHmin}
		-	-	107	μA	V_{ILmax}
Pull-down current for S pad	I_{PDL_S} CC	-	-	100	μA	V_{IHmin}
		46	-	-	μA	V_{ILmax}
Input Leakage current Class S	I_{OZS} CC	-350	-	350	nA	Analog Inputs with pull down diagnostics
		-150	-	150	nA	else
Input voltage high for S pad	V_{IHS} SR	-	-	$(0.73 * V_{DDM}) - 0.25$	V	Hysteresis active
Input voltage low for S pad	V_{ILS} SR	$(0.52 * V_{DDM}) - 0.25$	-	-	V	Hysteresis active
Input low threshold variation for S pad ²⁾	V_{ILSD} SR	-50	-	50	mV	max. variation of 1ms; $V_{DDM} = \text{constant}$
Input capacitance for S pad	C_{INS} CC	-	-	10	pF	
Pad set-up time for S pad	t_{SETS} CC	-	-	100	ns	

- 1) Hysteresis is implemented to avoid metastable states and switching due to internal ground bounce. It can't be guaranteed that it suppresses switching due to external system noise.
- 2) V_{ILSD} is implemented to ensure J2716 specification. For details of dedicated pins please see AP32286 for details.

Table 3-16 Class I 5V

Parameter	Symbol	Values			Unit	Note / Test Condition
		Min.	Typ.	Max.		
Input frequency	f_{IN} SR	-	-	75	MHz	Hysteresis active
		-	-	150	MHz	Hysteresis inactive
Input Hysteresis for I pad ¹⁾	HYS_I CC	$0.07 * V_{EXT/FLEX}$	-	-	V	\overline{PORST} pad only
		$0.09 * V_{EXT/FLEX}$	-	-	V	AL
		$0.075 * V_{EXT/FLEX}$	-	-	V	TTL
Pull-up current for I pad	I_{PUHI} CC	30	-	-	μA	V_{IHmin} ; AL
		43	-	-	μA	V_{IHmin} ; TTL
		-	-	107	μA	V_{ILmax} ; AL and TTL

Electrical Specification 5 V / 3.3 V switchable Pads

Table 3-16 Class I 5V (cont'd)

Parameter	Symbol	Values			Unit	Note / Test Condition
		Min.	Typ.	Max.		
Pull-down current for I pad	I_{PDLI} CC	-	-	100	μ A	V_{IHmin} : AL and TTL
		46	-	-	μ A	V_{ILmax} : AL
		21	-	-	μ A	V_{ILmax} : TTL
Input Leakage Current for I pad	I_{OZI} CC	-150	-	150	nA	$(0.1 \cdot V_{EXT/FLEX}) < V_{IN} < (0.9 \cdot V_{EXT/FLEX})$
		-350	-	350	nA	else
Input high voltage for I pad	V_{IHI} SR	2.03 ²⁾	-	-	V	Hysteresis active, TTL
		$(0.73 \cdot V_{EXT/FLEX}) - 0.25$	-	-	V	Hysteresis active; AL; not available for the \overline{PORST} pad
Input low voltage for I pad	V_{ILI} SR	-	-	0.8 ³⁾	V	Hysteresis active, TTL
		-	-	$(0.52 \cdot V_{EXT/FLEX}) - 0.25$	V	Hysteresis active; AL; not available for the \overline{PORST} pad
Input low / high voltage for I pad	V_{ILHI} CC	1.85	-	3.0	V	Hysteresis inactive
Pad set-up time for I pad	t_{SETI} CC	-	-	100	ns	

1) Hysteresis is implemented to avoid metastable states and switching due to internal ground bounce. It can't be guaranteed that it suppresses switching due to external system noise.

2) $V_{IHx} = 0.27 \cdot V_{EXT/FLEX} + 0.545V$

3) $V_{ILx} = 0.17 \cdot V_{EXT/FLEX}$

Table 3-17 Class I 3.3V

Parameter	Symbol	Values			Unit	Note / Test Condition
		Min.	Typ.	Max.		
Input frequency	f_{IN} SR	-	-	50	MHz	Hysteresis active
		-	-	100	MHz	Hysteresis inactive
Input Hysteresis for I pad ¹⁾	$HYSI$ CC	$0.045 \cdot V_{EXT/FLEX}$	-	-	V	\overline{PORST} pad only
		$0.05 \cdot V_{EXT/FLEX}$	-	-	V	AL and TTL
Pull-up current for I pad	I_{PUHI} CC	17	-	-	μ A	V_{IHmin} : AL
		19	-	-	μ A	V_{IHmin} : TTL
		-	-	75	μ A	V_{ILmax} : AL and TTL
Pull-down current for I pad	I_{PDLI} CC	-	-	75	μ A	V_{IHmin} : AL and TTL
		22	-	-	μ A	V_{ILmax} : AL
		11	-	-	μ A	V_{ILmax} : TTL
Input Leakage Current for I pad	I_{OZI} CC	-150	-	150	nA	$(0.1 \cdot V_{EXT/FLEX}) < V_{IN} < (0.9 \cdot V_{EXT/FLEX})$
		-350	-	350	nA	else

Table 3-17 Class I 3.3V (cont'd)

Parameter	Symbol	Values			Unit	Note / Test Condition
		Min.	Typ.	Max.		
Input high voltage for I pad	V_{IH1} SR	1.6 ²⁾	-	-	V	Hysteresis active, TTL
		$(0.73 * V_{EXT/FLEX}) - 0.25$	-	-	V	Hysteresis active; AL; not available for the \overline{PORST} pad
Input low voltage for I pad	V_{IL1} SR	-	-	0.5 ³⁾	V	Hysteresis active, TTL
		-	-	$(0.52 * V_{EXT/FLEX}) - 0.25$	V	Hysteresis active; AL; not available for the \overline{PORST} pad
Input low / high voltage for I pad	V_{ILHI} CC	1.1	-	1.9	V	Hysteresis inactive
Pad set-up time for I pad	t_{SET1} CC	-	-	100	ns	

- 1) Hysteresis is implemented to avoid metastable states and switching due to internal ground bounce. It can't be guaranteed that it suppresses switching due to external system noise.
- 2) $V_{IHx} = 0.27 * V_{EXT/FLEX} + 0.545V$
- 3) $V_{ILx} = 0.17 * V_{EXT/FLEX}$

Table 3-18 Class A2

Parameter	Symbol	Values			Unit	Note / Test Condition
		Min.	Typ.	Max.		
Input frequency	f_{IN} SR	-	-	160	MHz	
Input Hysteresis for A2 pad ¹⁾	$HYS A2$ CC	0.1 * V_{DDP3}	-	-	V	TTL; else
		0.06 * V_{DDP3}	-	-	V	valid for P21.6 and P21.7
Input Leakage current for A2 pad	I_{OZA2} CC	-300	-	300	nA	$(0.1 * V_{EXT/FLEX}) < V_{IN} < (0.9 * V_{EXT/FLEX})$
		-800	-	500	nA	else
Pull-up current for A2 pad	I_{PUHA2} CC	-	-	100	μA	V_{IHmin}
		25	-	-	μA	V_{ILmax}
Pull-down current for A2 pad	I_{PDLA2} CC	23	-	-	μA	V_{IHmin}
		-	-	100	μA	V_{ILmax}
On-Resistance for A2 pad, weak driver ²⁾	$R_{DSONA2W}$ CC	100	200	325	Ohm	PMOS/NMOS ; $I_{OH}=0.5mA; I_{OL}=0.5mA$
On-Resistance for A2 pad, medium driver ²⁾	$R_{DSONA2M}$ CC	40	70	100	Ohm	PMOS/NMOS ; $I_{OH}=2mA; I_{OL}=2mA$
On-Resistance for A2 pad, strong driver ²⁾	$R_{DSONA2S}$ CC	20	35	50	Ohm	PMOS/NMOS ; $I_{OH}=8mA; I_{OL}=8mA$

Table 3-18 Class A2 (cont'd)

Parameter	Symbol	Values			Unit	Note / Test Condition
		Min.	Typ.	Max.		
Rise/fall time for A2 pad ³⁾	$t_{A2\ CC}$	-	-	$20+0.8 \cdot C_L$	ns	$C_L \leq 50\text{pF}$; pin out driver=weak
		-	-	$17.5+0.85 \cdot C_L$	ns	$C_L \geq 50\text{pF}$; $C_L \leq 200\text{pF}$; pin out driver=weak
		-	-	$12+0.16 \cdot C_L$	ns	$C_L \leq 50\text{pF}$; pin out driver=medium
		-	-	$11.5+0.17 \cdot C_L$	ns	$C_L \geq 50\text{pF}$; $C_L \leq 200\text{pF}$; pin out driver=medium
		-	-	$6+0.06 \cdot C_L$	ns	$C_L \leq 50\text{pF}$; edge=medium; pin out driver=strong
		-	-	$5.5+0.07 \cdot C_L$	ns	$C_L \geq 50\text{pF}$; $C_L \leq 200\text{pF}$; edge=medium; pin out driver=strong
		-	-	$0.0+0.12 \cdot C_L$	ns	$C_L \leq 50\text{pF}$; edge=sharp; pin out driver=strong
		-	-	$0.0+0.12 \cdot C_L$	ns	$C_L \geq 50\text{pF}$; $C_L \leq 200\text{pF}$; edge=sharp; pin out driver=strong
Input high voltage for A2 pad	$V_{IHA2\ SR}$	2.04 ⁴⁾	-	-	V	TTL; valid for all A2 pads except TMS/DAP1, TRST, and TCK/DAP0
		$0.7 \cdot V_{DDP3}$	-	-	V	valid for TMS/DAP1, TRST, and TCK/DAP0
Input low voltage for A2 pad	$V_{ILA2\ SR}$	-	-	0.8 ⁵⁾	V	TTL; valid for all A2 pads except TMS/DAP1, TRST, and TCK/DAP0
		-	-	$0.3 \cdot V_{DDP3}$	V	valid for TMS/DAP1, TRST, and TCK/DAP0
Pad set-up time for A2 pad	$t_{SETA2\ CC}$	-	-	100	ns	
Deviation of symmetry for rising and falling edges	$SYM\ CC$	-	-	20	%	

1) Hysteresis is implemented to avoid metastable states and switching due to internal ground bounce. It can't be guaranteed that it suppresses switching due to external system noise.

2) For currents smaller than the $I_{OL/OH}$ from the test condition the defined Max. value stays unchanged.

3) Rise / fall times are defined 10% - 90% of V_{DDP3} .

4) $V_{IHx} = 0.57 \cdot V_{DDP3} - 0.03\text{V}$

5) $V_{ILx} = 0.25 \cdot V_{DDP3} + 0.058\text{V}$

Table 3-19 Driver Mode Selection for LP Pads

PDx.2	PDx.1	PDx.0	Port Functionality	Driver Setting
X	X	0	Speed grade 1	medium (LPm)
X	X	1	Speed grade 2	weak (LPw)

Table 3-20 Driver Mode Selection for MP / MP+ Pads

PDx.2	PDx.1	PDx.0	Port Functionality	Driver Setting
X	0	0	Speed grade 1	Strong sharp edge (MPss / MP+ss)
X	0	1	Speed grade 2	Strong medium edge (MPsm / MP+sm)
X	1	0	Speed grade 3	medium (MPm / MP+m)
X	1	1	Speed grade 4	weak (MPw / MP+w)

Table 3-21 Driver Mode Selection for A2 Pads

PDx.2	PDx.1	PDx.0	Port Functionality	Driver Setting
X	0	0	Speed grade 1	Strong sharp edge
X	0	1	Speed grade 2	Strong medium edge
X	1	0	Speed grade 3	medium
X	1	1	Speed grade 4	weak

Table 3-22 Driver Mode Selection for F Pads

PDx.2	PDx.1	PDx.0	Port Functionality	Driver Setting
X	0	0	Speed grade 1	Reduced Strong sharp edge
X	0	1	Speed grade 2	Reduced Strong medium edge
X	1	0	Speed grade 3	medium
X	1	1	Speed grade 4	weak

3.6 High performance LVDS Pads (LVDSH)

This LVDS pad type is used for the high speed chip to chip communication interface of the new TC290 / TC297 / TC298 / TC299. It compose out of a LVDSH pad and a Class F pad.

This pad combination is always supplied by the 3.3V supply rail.

Table 3-23 Class F

Parameter	Symbol	Values			Unit	Note / Test Condition
		Min.	Typ.	Max.		
Input frequency	f_{IN} SR	-	-	75	MHz	
Input Hysteresis for F pad ¹⁾	$HYSF$ CC	0.1 * V_{DDP3}	-	-	V	TTL
Input Leakage Current for F pad	I_{OZF} CC	-1000	-	-	nA	$(0.1 * V_{DDP3}) < V_{IN} < (0.9 * V_{DDP3})$; valid for P21.0, P21.1, P21.2 and P21.3; $T_J = 150^\circ\text{C}$
		-	-	1000	nA	$(0.1 * V_{DDP3}) < V_{IN} < (0.9 * V_{DDP3})$; valid for P21.0, P21.1, P21.2 and P21.3; $T_J = 150^\circ\text{C}$
		-1500	-	1500	nA	$(0.1 * V_{DDP3}) < V_{IN} < (0.9 * V_{DDP3})$; valid for P21.0, P21.1, P21.2 and P21.3; $T_J = 170^\circ\text{C}$
		-300	-	300	nA	$(0.1 * V_{DDP3}) < V_{IN} < (0.9 * V_{DDP3})$; valid for P21.4 and P21.5
		-	-	2000	nA	else; valid for P21.0, P21.1, P21.2 and P21.3; $T_J = 150^\circ\text{C}$
		-2000	-	-	nA	else; valid for P21.0, P21.1, P21.2 and P21.3; $T_J = 150^\circ\text{C}$
		-3000	-	3000	nA	else; valid for P21.0, P21.1, P21.2 and P21.3; $T_J = 170^\circ\text{C}$
		-600	-	600	nA	else; valid for P21.4 and P21.5
Pull-up current for F pad	I_{PUHF} CC	25	-	-	μA	V_{IHmin}
		-	-	100	μA	V_{ILmax}
Pull-down current for class F pads	I_{PDLF} CC	-	-	100	μA	V_{IHmin}
		25	-	-	μA	V_{ILmax}
On resistance for F pad, weak driver ²⁾	R_{DSONFW} CC	100	200	325	Ohm	PMOS/NMOS ; $I_{OH}=0.5\text{mA}$; $I_{OL}=0.5\text{mA}$

Electrical Specification High performance LVDS Pads (LVDSH)

Table 3-23 Class F (cont'd)

Parameter	Symbol	Values			Unit	Note / Test Condition
		Min.	Typ.	Max.		
On resistance for F pad, medium driver ²⁾	R_{DSONFM} CC	40	70	100	Ohm	PMOS/NMOS ; $I_{OH}=2mA$; $I_{OL}=2mA$
On resistance for F pad, strong driver ²⁾	R_{DSONFS} CC	20	50	80	Ohm	PMOS/NMOS ; $I_{OH}=4mA$; $I_{OL}=4mA$
Rise/fall time for F pad ³⁾	t_{rff} CC	-	-	$20+0.8 \cdot C_L$	ns	$C_L \leq 50pF$; pin out driver=weak
		-	-	$17.5+0.85 \cdot C_L$	ns	$C_L \geq 50pF$; $C_L \leq 200pF$; pin out driver=weak
		-	-	$12+0.16 \cdot C_L$	ns	$C_L \leq 50pF$; pin out driver=medium
		-	-	$11.5+0.17 \cdot C_L$	ns	$C_L \geq 50pF$; $C_L \leq 200pF$; pin out driver=medium
		-	-	$7+0.16 \cdot C_L$	ns	$C_L \leq 50pF$; edge=medium ; pin out driver=reduced strong
		-	-	$6.5+0.17 \cdot C_L$	ns	$C_L \geq 50pF$; $C_L \leq 200pF$; edge=medium ; pin out driver>reduced strong
		-	-	$4+0.16 \cdot C_L$	ns	$C_L \leq 50pF$; edge=sharp ; pin out driver=reduced strong
		-	-	$3.5+0.17 \cdot C_L$	ns	$C_L \geq 50pF$; $C_L \leq 200pF$; edge=sharp ; pin out driver=reduced strong
Input high voltage for F pad	V_{IHf} SR	2.04 ⁴⁾	-	-	V	TTL
Input low voltage for F pad	V_{ILf} SR	-	-	0.8 ⁵⁾	V	TTL
Pad set-up time for F pad	t_{SETf} CC	-	-	100	ns	
Deviation of symmetry for rising and falling edges	SYM CC	-	-	20	%	

1) Hysteresis is implemented to avoid metastable states and switching due to internal ground bounce. It can't be guaranteed that it suppresses switching due to external system noise.

2) For currents smaller than the $I_{OL/OH}$ from the test condition the defined Max. value stays unchanged.

3) Rise / fall times are defined 10% - 90% of V_{DDP3} .

4) $V_{IHx} = 0.57 \cdot V_{DDP3} - 0.03V$

5) $V_{ILx} = 0.25 \cdot V_{DDP3} + 0.058V$

$C_L = 2.5$ pF for all LVDSH parameters.

Electrical Specification High performance LVDS Pads (LVDSH)

Table 3-24 LVDSH - IEEE standard LVDS general purpose link (GPL)

Parameter	Symbol	Values			Unit	Note / Test Condition
		Min.	Typ.	Max.		
Output impedance	R_0 CC	40	-	140	Ohm	$V_{cm} = 1.0$ V and 1.4 V
Rise time ¹⁾	t_{rise20} CC	-	-	0.5	ns	ZL = 100 Ohm $\pm 5\%$ @2 pF
Fall time ¹⁾	t_{fall20} CC	-	-	0.5	ns	ZL = 100 Ohm $\pm 5\%$ @ 2 pF
Output differential voltage	V_{OD} CC	250	-	400	mV	RT = 100 Ohm $\pm 5\%$
Output voltage high	V_{OH} CC	-	-	1475	mV	RT = 100 Ohm $\pm 5\%$ (400 mV/2) + 1275 mV
Output voltage low	V_{OL} CC	925	-	-	mV	RT = 100 Ohm $\pm 5\%$
Output offset (Common mode) voltage	V_{OS} CC	1125	-	1275	mV	RT = 100 Ohm $\pm 5\%$
Input voltage range	V_1 SR	0	-	1600	mV	Driver ground potential difference < 925 mV; RT = 100 Ohm $\pm 10\%$
		0	-	2000	mV	Driver ground potential difference < 925 mV; RT = 100 Ohm $\pm 20\%$
Input differential threshold	V_{idth} SR	-100	-	100	mV	Driver ground potential difference < 925 mV
Delta output impedance	$dR0$ SR	-	-	10	%	$V_{cm} = 1.0$ V and 1.4 V (mismatch Pd and Pn)
Change in VOS between 0 and 1	$dVOS$ CC	-	-	25	mV	RT = 100 Ohm $\pm 5\%$
Change in Vod between 0 and 1	$dVod$ CC	-	-	25	mV	RT = 100 Ohm $\pm 5\%$
Duty cycle	t_{duty} CC	45	-	55	%	

 1) Rise / fall times are defined for 20% - 80% of V_{OD}
Table 3-25 LVDSH - IEEE standard LVDS reduced link (REDL)

Parameter	Symbol	Values			Unit	Note / Test Condition
		Min.	Typ.	Max.		
Output impedance	R_0 CC	40	-	140	Ohm	$V_{cm} = 1.0$ V and 1.4 V
Output differential voltage	V_{OD} CC	150	-	250	mV	RT = 100 Ohm $\pm 5\%$
Output voltage high	V_{OH} CC	-	-	1375	mV	RT = 100 Ohm $\pm 5\%$
Output voltage low	V_{OL} CC	1025	-	-	mV	RT = 100 Ohm $\pm 5\%$
Output offset (Common mode) voltage	V_{OS} CC	1125	-	1275	mV	RT = 100 Ohm $\pm 5\%$
Input voltage range	V_1 SR	825	-	1575	mV	Driver ground potential difference < 50 mV

Electrical Specification High performance LVDS Pads (LVDSH)

Table 3-25 LVDSH - IEEE standard LVDS reduced link (REDL) (cont'd)

Parameter	Symbol	Values			Unit	Note / Test Condition
		Min.	Typ.	Max.		
Input differential threshold	V_{idth} SR	-100	-	100	mV	Driver ground potential difference < 50 mV
Change in VOS between 0 and 1	$dVOS$ CC	-	-	25	mV	RT = 100 Ohm \pm 5%
Change in Vod between 0 and 1	$dVod$ CC	-	-	25	mV	RT = 100 Ohm \pm 5%
Duty cycle	t_{duty} CC	45	-	55	%	
V_{OD} Fall time ¹⁾	t_{fall10} CC	-	-	0.5	ns	ZL = 100 Ohm \pm 5% @ 2pF
V_{OD} Rise time ¹⁾	t_{rise10} CC	-	-	0.5	ns	ZL = 100 Ohm \pm 5% @ 2pF

1) Rise / fall times are defined for 10% - 90% of V_{OD}

default after start-up = CMOS function

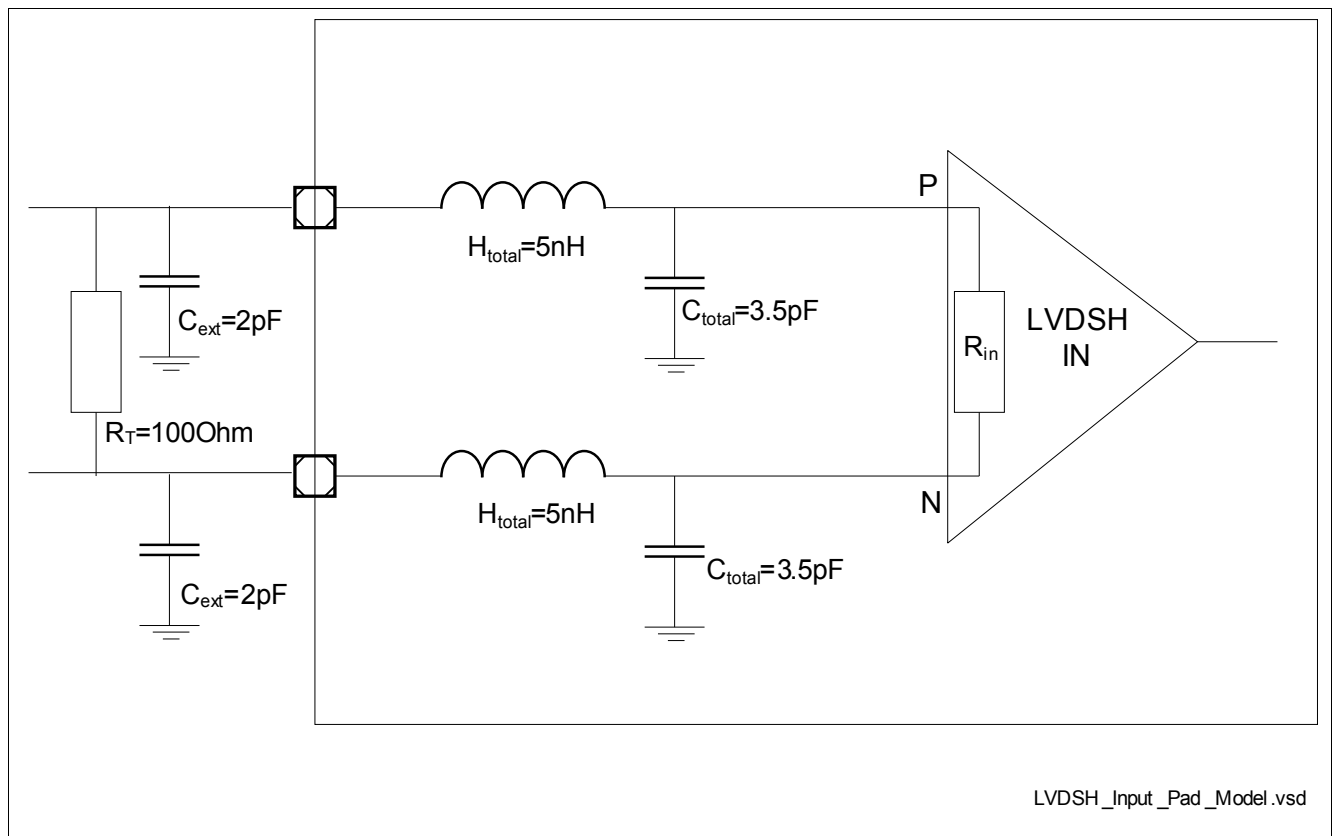

Figure 3-1 LVDSH pad Input model

3.7 Medium performance LVDS Pads (LVDSM)

This LVDS pad type is used for the medium speed chip to chip communication interface of the new TC290 / TC297 / TC298 / TC299. It compose out of a LVDSM pad and a MP pad.

This pad combination is always supplied by the 5V or 3.3V.

For the parameters of the MP pad please see [Chapter 3.5](#).

Table 3-26 LVDSM

Parameter	Symbol	Values			Unit	Note / Test Condition
		Min.	Typ.	Max.		
Output impedance	R_O CC	40	100	140	Ohm	
Fall time	t_F CC	-	-	2.5	ns	$Z_{load} = 100$ Ohm; termination 100 Ohm $\pm 1\%$
Rise time	t_R CC	-	-	2.5	ns	$Z_{load} = 100$ Ohm; termination 100 Ohm $\pm 1\%$
Pad set-up time	t_{SET_LVDS} CC	-	10	13	μs	
Output Differential Voltage	V_{OD} CC	250	-	400	mV	termination 100 Ohm $\pm 1\%$
Output voltage high	V_{OH} CC	-	-	1475	mV	termination 100 Ohm $\pm 1\%$
Output voltage low	V_{OL} CC	925	-	-	mV	termination 100 Ohm $\pm 1\%$
Output Offset Voltage	V_{OS} CC	1125	-	1275	mV	termination 100 Ohm $\pm 1\%$

default after start-up = CMOS function

3.8 VADC Parameters

VADC parameter are valid for $V_{DDM} = 4.5 \text{ V}$ to 5.5 V .

This table also covers the parameters for Class D pads.

Table 3-27 VADC

Parameter	Symbol	Values			Unit	Note / Test Condition
		Min.	Typ.	Max.		
Analog reference voltage ¹⁾	V_{AREF} SR	$V_{AGND} + 1.0$	-	$V_{DDM} + 0.05$	V	
Analog reference ground	V_{AGND} SR	$V_{SSM} - 0.05$	-	$V_{SSM} + 0.05$	V	
Analog input voltage range	V_{AIN} SR	V_{AGND}	-	V_{AREF}	V	
Converter reference clock	f_{ADCI} SR	2	-	20	MHz	
Charge consumption per conversion ^{2) 3)}	Q_{CONV} CC	-	50	75	pC	$V_{AIN} = 5 \text{ V}$, charge consumed from reference pin, precharging disabled
		-	10	22	pC	$V_{AIN} = 5 \text{ V}$, charge consumed from reference pin, precharging enabled
Conversion time for 12-bit result	t_{C12} CC	-	$(16 + \text{STC}) \times t_{ADCI} + 2 \times t_{VADC}$	-		Includes sample time and post calibration
Conversion time for 10-bit result	t_{C10} CC	-	$(14 + \text{STC}) \times t_{ADCI} + 2 \times t_{VADC}$	-		Includes sample time
Conversion time for 8-bit result	t_{C8} CC	-	$(12 + \text{STC}) \times t_{ADCI} + 2 \times t_{VADC}$	-		Includes sample time
Conversion time for fast compare mode	t_{CF} CC	-	$(4 + \text{STC}) \times t_{ADCI} + 2 \times t_{VADC}$	-		Includes sample time
Broken wire detection delay against V_{AGND} ⁴⁾	t_{BWG} CC	-	-	120	cycles	Result below 10%
Broken wire detection delay against V_{AREF} ⁵⁾	t_{BWR} CC	-	-	60	cycles	Result above 80%
Input leakage at analog inputs	I_{OZ1} CC	-350	-	350	nA	Analog Inputs overlaid with class LP pads or pull down diagnostics
		-150	-	150	nA	else
Total Unadjusted Error ¹⁾	TUE CC	-4 ⁶⁾	-	4 ⁶⁾	LSB	12-bit resolution

Electrical Specification VADC Parameters

Table 3-27 VADC (cont'd)

Parameter	Symbol	Values			Unit	Note / Test Condition
		Min.	Typ.	Max.		
INL Error	EA_{INL} CC	-3	-	3	LSB	12-bit resolution
Gain Error ¹⁾	EA_{GAIN} CC	-3.5	-	3.5	LSB	12-bit resolution
DNL error ¹⁾	EA_{DNL} CC	-3	-	3	LSB	12-bit resolution
Offset Error ¹⁾	EA_{OFF} CC	-4	-	4	LSB	12-bit resolution
Total capacitance of an analog input	C_{AINT} CC	-	-	30	pF	
Switched capacitance of an analog input	C_{AINS} CC	2	4	7	pF	
Resistance of the analog input path	R_{AIN} CC	-	-	1.5	kOhm	else
		-	-	1.8	kOhm	valid for analog inputs mapped to GPIOs
Switched capacitance of a reference input	C_{AREFS} CC	-	-	30	pF	
RMS Noise ⁷⁾	EN_{RMS} CC	-	0.5	0.8 ⁶⁾⁸⁾	LSB	
Positive reference V_{AREFX} pin leakage	I_{OZ2} CC	-7	-	7	μA	$V_{AREFX} = V_{AREF2};$ $V_{AREF} > V_{DDM}V;$ $T_J > 150^\circ C$
		-4	-	4	μA	$V_{AREFX} = V_{AREF2};$ $V_{AREF} > V_{DDM}V;$ $T_J \leq 150^\circ C$
		-2	-	3	μA	$V_{AREFX} = V_{AREF2};$ $V_{AREF} \leq V_{DDM}V;$ $T_J > 150^\circ C$
		-1	-	1	μA	$V_{AREFX} = V_{AREF2};$ $V_{AREF} \leq V_{DDM}V;$ $T_J \leq 150^\circ C$
Negative reference V_{AGNDx} pin leakage	I_{OZ3} CC	-13	-	13	μA	$V_{AGNDx} = V_{AGND2};$ $V_{AGND} < V_{SSM}V;$ $T_J > 150^\circ C$
		-7	-	7	μA	$V_{AGNDx} = V_{AGND2};$ $V_{AGND} < V_{SSM}V;$ $T_J \leq 150^\circ C$
		-4.5	-	2.5	μA	$V_{AGNDx} = V_{AGND2};$ $V_{AREF} \leq V_{DDM}V;$ $T_J > 150^\circ C$
		-2.5	-	1	μA	$V_{AGNDx} = V_{AGND2};$ $V_{AREF} \leq V_{DDM}V;$ $T_J \leq 150^\circ C$
Resistance of the reference input path	R_{AREF} CC	-	-	1	kOhm	
CSD resistance ⁹⁾	R_{CSD} CC	-	-	28	kOhm	

Electrical Specification VADC Parameters

Table 3-27 VADC (cont'd)

Parameter	Symbol	Values			Unit	Note / Test Condition
		Min.	Typ.	Max.		
Resistance of the multiplexer diagnostics pull-down device	R_{MDD} CC	$25 + 1 \cdot V_{IN}$	-	$35 - 8 \cdot V_{IN}$	kOhm	$0 \text{ V} \leq V_{IN} \leq 2.5 \text{ V}$
		$-5 + 13 \cdot V_{IN}$	-	$15 + 16 \cdot V_{IN}$	kOhm	$2.5 \text{ V} \leq V_{IN} \leq V_{DDM}$
Resistance of the multiplexer diagnostics pull-up device	R_{MDU} CC	$45 - 6 \cdot V_{IN}$	-	$90 - 16 \cdot V_{IN}$	kOhm	$0 \text{ V} \geq V_{IN} \leq 2.5 \text{ V}$
		$40 - 4 \cdot V_{IN}$	-	$65 - 6 \cdot V_{IN}$	kOhm	$2.5 \text{ V} \leq V_{IN} \leq V_{DDM}$
Resistance of the pull-down test device ¹⁰⁾	R_{PDD} CC	-	-	0.3	kOhm	
CSD voltage accuracy ^{11) 12)}	$dVCSD$ CC	-	-	10	%	
Wakeup time	t_{WU} CC	-	-	12	μs	

- 1) If the reference voltage is reduced by the factor k ($k < 1$), TUE, DNL, INL, Gain, and Offset errors increase also by the factor $1/k$. V_{AREF} must be decoupled with an external capacitor.
- 2) For $QCONV = X \text{ pC}$ and a conversion time of $1 \text{ } \mu\text{s}$ a rms value of $X \text{ } \mu\text{A}$ results for I_{AREFX} .
- 3) For the details of the mapping for a VADC group to pin V_{AREFX} please see the User's Manual.
- 4) The broken wire detection delay against V_{AGND} is measured in numbers of consecutive precharge cycles at a conversion rate higher than 1 conversion per 500 ms.
- 5) The broken wire detection delay against V_{AREF} is measured in numbers of consecutive precharge cycles at a conversion rate higher than 1 conversion per 10 ms. This function is influenced by leakage current, in particular at high temperature.
- 6) Resulting worst case combined error is arithmetic combination of TUE and EN_{RMS} .
- 7) This parameter is valid for soldered devices and requires careful analog board design.
- 8) Value is defined for one sigma Gauss distribution.
- 9) In order to avoid an additional error due to incomplete sampling, the sampling time shall be set greater than $5 \cdot R_{CSD} \cdot C_{AINS}$.
- 10) The pull-down resistor R_{PDD} is connected between the input pad and the analog multiplexer. The input pad itself adds another 200-Ohm series resistance, when measuring through the pin.
- 11) CSD: Converter Self Diagnostics, for details please consult the User's Manual.
- 12) Note, that in case CSD voltage is chosen to nom. 1/3 or 2/3 of V_{AREF} voltage, the reference voltage is loaded with a current of max. $V_{AREF} / 45 \text{ kOhm}$.

The following VADC parameter are valid for $V_{DDM} = 2.97 \text{ V}$ to 4.5 V .

This table also covers the parameters for Class D pads.

Table 3-28 VADC_33V

Parameter	Symbol	Values			Unit	Note / Test Condition
		Min.	Typ.	Max.		
Analog reference voltage ¹⁾	V_{AREF} SR	$V_{AGND} + 1.0$	-	$V_{DDM} + 0.05$	V	
Analog reference ground	V_{AGND} SR	$V_{SSM} - 0.05$	-	$V_{SSM} + 0.05$	V	
Analog input voltage range	V_{AIN} SR	V_{AGND}	-	V_{AREF}	V	
Converter reference clock	f_{ADCI} SR	2	-	20	MHz	

Electrical Specification VADC Parameters

Table 3-28 VADC_33V (cont'd)

Parameter	Symbol	Values			Unit	Note / Test Condition
		Min.	Typ.	Max.		
Charge consumption per conversion ^{2) 3)}	Q_{CONV} CC	-	35	50	pC	$V_{AIN} = 3.3$ V, charge consumed from reference pin, precharging disabled
		-	8	17	pC	$V_{AIN} = 3.3$ V, charge consumed from reference pin, precharging enabled
Conversion time for 12-bit result	t_{C12} CC	-	$(16 + \text{STC}) \times t_{ADCI} + 2 \times t_{VADC}$	-		Includes sample time and post calibration
Conversion time for 10-bit result	t_{C10} CC	-	$(14 + \text{STC}) \times t_{ADCI} + 2 \times t_{VADC}$	-		Includes sample time
Conversion time for 8-bit result	t_{C8} CC	-	$(12 + \text{STC}) \times t_{ADCI} + 2 \times t_{VADC}$	-		Includes sample time
Conversion time for fast compare mode	t_{CF} CC	-	$(4 + \text{STC}) \times t_{ADCI} + 2 \times t_{VADC}$	-		Includes sample time
Broken wire detection delay against V_{AGND} ⁴⁾	t_{BWG} CC	-	-	120	cycles	Result below 10%
Broken wire detection delay against V_{AREF} ⁵⁾	t_{BWR} CC	-	-	60	cycles	Result above 80%
Input leakage at analog inputs	I_{OZ1} CC	-350	-	350	nA	Analog Inputs overlaid with class LP pads or pull down diagnostics
		-150	-	150	nA	else
Total Unadjusted Error ¹⁾	TUE CC	-12 ⁶⁾	-	12 ⁶⁾	LSB	12-bit Resolution; $T_J > 150$ °C
		-6 ⁶⁾	-	6 ⁶⁾	LSB	12-bit Resolution; $T_J \leq 150$ °C
INL Error	EA_{INL} CC	-12	-	12	LSB	12-bit Resolution; $T_J > 150$ °C
		-5	-	5	LSB	12-bit Resolution; $T_J \leq 150$ °C
Gain Error ¹⁾	EA_{GAIN} CC	-6	-	6	LSB	12-bit Resolution; $T_J > 150$ °C
		-5.5	-	5.5	LSB	12-bit Resolution; $T_J \leq 150$ °C

Electrical Specification VADC Parameters

Table 3-28 VADC_33V (cont'd)

Parameter	Symbol	Values			Unit	Note / Test Condition
		Min.	Typ.	Max.		
DNL error ¹⁾	EA_{DNL} CC	-4	-	4	LSB	12-bit resolution
Offset Error ¹⁾	EA_{OFF} CC	-6	-	6	LSB	12-bit Resolution; $T_J > 150^\circ\text{C}$
		-5	-	5	LSB	12-bit Resolution; $T_J \leq 150^\circ\text{C}$
Total capacitance of an analog input	C_{AINT} CC	-	-	30	pF	
Switched capacitance of an analog input	C_{AINS} CC	2	4	7	pF	
Resistance of the analog input path	R_{AIN} CC	-	-	4.5	kOhm	
Switched capacitance of a reference input	C_{AREFS} CC	-	-	30	pF	
RMS Noise ⁷⁾	EN_{RMS} CC	-	-	1.7 ⁶⁾⁸⁾	LSB	target
Positive reference V_{AREFX} pin leakage	I_{OZ2} CC	-6	-	6	μA	$V_{AREFX} = V_{AREF2}$; $V_{AREF} > V_{DDM}V$; $T_J > 150^\circ\text{C}$
		-3.5	-	3.5	μA	$V_{AREFX} = V_{AREF2}$; $V_{AREF} > V_{DDM}V$; $T_J \leq 150^\circ\text{C}$
		-2	-	2.5	μA	$V_{AREFX} = V_{AREF2}$; $V_{AREF} \leq V_{DDM}V$; $T_J > 150^\circ\text{C}$
		-1	-	1	μA	$V_{AREFX} = V_{AREF2}$; $V_{AREF} \leq V_{DDM}V$; $T_J \leq 150^\circ\text{C}$
Negative reference V_{AGNDx} pin leakage	I_{OZ3} CC	-12	-	12	μA	$V_{AGNDx} = V_{AGND2}$; $V_{AGND} < V_{SSM}V$; $T_J > 150^\circ\text{C}$
		-6.5	-	6.5	μA	$V_{AGNDx} = V_{AGND2}$; $V_{AGND} < V_{SSM}V$; $T_J \leq 150^\circ\text{C}$
		-2.2	-	2	μA	$V_{AGNDx} = V_{AGND2}$; $V_{AREF} \leq V_{DDM}V$; $T_J > 150^\circ\text{C}$
		-1	-	1	μA	$V_{AGNDx} = V_{AGND2}$; $V_{AREF} \leq V_{DDM}V$; $T_J \leq 150^\circ\text{C}$
Resistance of the reference input path	R_{AREF} CC	-	-	3	kOhm	
CSD resistance ⁹⁾	R_{CSD} CC	-	-	28	kOhm	

Table 3-28 VADC_33V (cont'd)

Parameter	Symbol	Values			Unit	Note / Test Condition
		Min.	Typ.	Max.		
Resistance of the multiplexer diagnostics pull-down device	R_{MDD} CC	$25 + 3 \cdot V_{IN}$	-	$40 + 12 \cdot V_{IN}$	kOhm	$0 \text{ V} \leq V_{IN} \leq 1.667 \text{ V}$
		$0 + 18 \cdot V_{IN}$	-	$0 + 18 \cdot V_{IN}$	kOhm	$1.667 \text{ V} \leq V_{IN} \leq V_{DDM}$
Resistance of the multiplexer diagnostics pull-up device	R_{MDU} CC	$60 - 12 \cdot V_{IN}$	-	$120 - 30 \cdot V_{IN}$	kOhm	$0 \text{ V} \leq V_{IN} \leq 1.667 \text{ V}$
		$55 - 9 \cdot V_{IN}$	-	$95 - 15 \cdot V_{IN}$	kOhm	$1.667 \text{ V} \leq V_{IN} \leq V_{DDM}$
Resistance of the pull-down test device ¹⁰⁾	R_{PDD} CC	-	-	0.9	kOhm	
CSD voltage accuracy ^{11) 12)}	$dVCSD$ CC	-	-	10	%	
Wakeup time	t_{WU} CC	-	-	12	μs	

- 1) If the reference voltage is reduced by the factor k ($k < 1$), TUE, DNL, INL, Gain, and Offset errors increase also by the factor $1/k$. V_{AREF} must be decoupled with an external capacitor.
- 2) For $QCONV = X$ pC and a conversion time of $1 \mu\text{s}$ a rms value of $X \mu\text{A}$ results for I_{AREFX} .
- 3) For the details of the mapping for a VADC group to pin V_{AREFX} please see the User's Manual.
- 4) The broken wire detection delay against V_{AGND} is measured in numbers of consecutive precharge cycles at a conversion rate higher than 1 conversion per 500 ms.
- 5) The broken wire detection delay against V_{AREF} is measured in numbers of consecutive precharge cycles at a conversion rate higher than 1 conversion per 10 ms. This function is influenced by leakage current, in particular at high temperature.
- 6) Resulting worst case combined error is arithmetic combination of TUE and EN_{RMS} .
- 7) This parameter is valid for soldered devices and requires careful analog board design.
- 8) Value is defined for one sigma Gauss distribution.
- 9) In order to avoid an additional error due to incomplete sampling, the sampling time shall be set greater than $5 \cdot R_{CSD} \cdot C_{AINS}$.
- 10) The pull-down resistor R_{PDD} is connected between the input pad and the analog multiplexer. The input pad itself adds another 200-Ohm series resistance, when measuring through the pin.
- 11) CSD: Converter Self Diagnostics, for details please consult the User's Manual.
- 12) Note, that in case CSD voltage is chosen to nom. 1/3 or 2/3 of V_{AREF} voltage, the reference voltage is loaded with a current of max. $V_{AREF} / 45 \text{ kOhm}$.

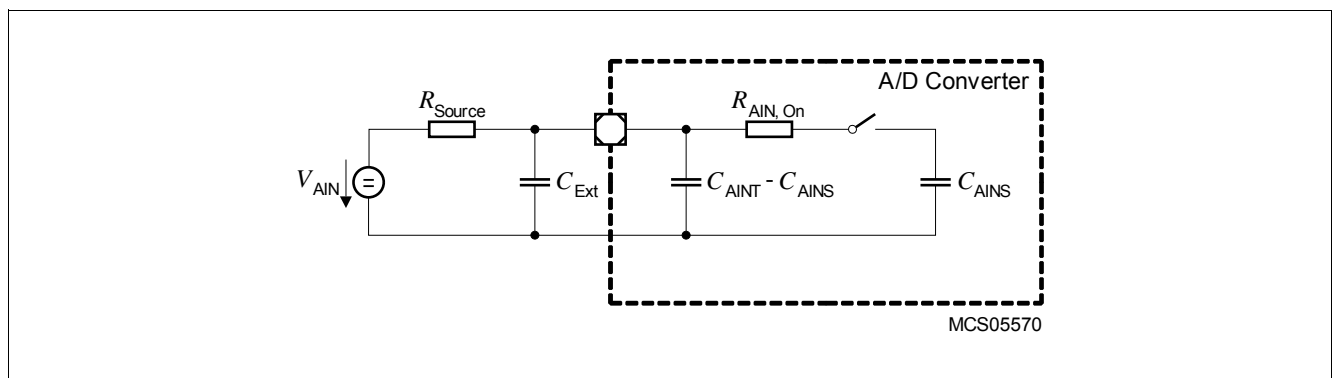

Figure 3-2 Equivalent Circuitry for Analog Inputs

3.9 DSADC Parameters

The following DSADC parameter are valid for $V_{DDM} = 4.5 \text{ V}$ to 5.5 V .

Table 3-29 DSADC

Parameter	Symbol	Values			Unit	Note / Test Condition
		Min.	Typ.	Max.		
Analog input voltage range ¹⁾	V_{DSIN} SR	0	-	5	V	single ended
		0	-	10	V	differential; $V_{DSxP} - V_{DSxN}$
Reference load current	I_{REF} SR	-	4.5	5.5	μA	per twin-modulator (1 or 2 channels)
Modulator clock frequency ²⁾	f_{MOD} SR	10	-	20	MHz	
Gain error	ED_{GAIN} CC	-1	-	1 ³⁾	%	Calibrated once
		-3.5 ⁴⁾	-	3.5 ⁴⁾	%	Uncalibrated
		-0.2	-	0.2 ⁵⁾	%	calibrated; GAIN = 1; MODCFG.INCFGx=01
DC offset error	ED_{OFF} CC	-5	-	5 ⁵⁾	mV	calibrated
		-50	-	50	mV	calibrated once
		-100 ⁴⁾	0 ⁴⁾	100 ⁴⁾	mV	gain = 1; uncalibrated
Common Mode Rejection Ratio	ED_{CM} CC	200	500	-		
Input impedance ⁶⁾	R_{DAIN} CC	100	130	170	kOhm	Exact value ($\pm 1\%$) available in UCB
Signal-Noise Ratio ^{7) 8) 9) 10)}	SNR CC	80	-	-	dB	$f_{PB} = 30 \text{ kHz}$; $V_{DDM} = \pm 5\%$; $f_{MOD} = 20 \text{ MHz}$; GAIN = 1
		78	-	-	dB	$f_{PB} = 50 \text{ kHz}$; $V_{DDM} = \pm 5\%$; $f_{MOD} = 20 \text{ MHz}$; GAIN = 1
		70	-	-	dB	$f_{PB} = 100 \text{ kHz}$; $V_{DDM} = \pm 10\%$; $f_{MOD} = 20 \text{ MHz}$; GAIN = 1
		74	-	-	dB	$f_{PB} = 100 \text{ kHz}$; $V_{DDM} = \pm 5\%$; $f_{MOD} = 20 \text{ MHz}$; GAIN = 1
		76	-	-	dB	$f_{PB} = 30 \text{ kHz}$; $V_{DDM} = \pm 10\%$; $f_{MOD} = 20 \text{ MHz}$; GAIN = 1
		74	-	-	dB	$f_{PB} = 50 \text{ kHz}$; $V_{DDM} = \pm 10\%$; $f_{MOD} = 20 \text{ MHz}$; GAIN = 1
Pass band	f_{PB} CC	10 ¹¹⁾	-	100	kHz	Output data rate $f_D = f_{PB} * 3$
Pass band ripple ⁸⁾	df_{PB} CC	-1	-	1	%	
Output sampling rate	f_D CC	30	-	330	kHz	

Table 3-29 DSADC (cont'd)

Parameter	Symbol	Values			Unit	Note / Test Condition
		Min.	Typ.	Max.		
DC compensation factor	DCF CC	-3	-	-	dB	$10^{-5} f_D$
Positive reference V_{AREF1} pin leakage	I_{OZ5} CC	-2	-	2	μA	
Negative reference V_{AGND1} pin leakage	I_{OZ6} CC	-3	-	2	μA	
Stop band attenuation ⁸⁾	SBA CC	40	-	-	dB	$0.5 \dots 1 f_D$
		45	-	-	dB	$1 \dots 1.5 f_D$
		50	-	-	dB	$1.5 \dots 2 f_D$
		55	-	-	dB	$2 \dots 2.5 f_D$
		60	-	-	dB	$2.5 \dots OSR/2 f_D$
Reference ground voltage	V_{AGND} SR	V_{SSM}^- 0.05	-	V_{SSM}^+ 0.05	V	
Positive reference voltage	V_{AREF} SR	V_{DDMnom}^* 0.9	-	V_{DDM}^+ 0.05	V	
Common mode voltage accuracy	dV_{CM} CC	-100	-	100	mV	from selected voltage
Common mode hold voltage deviation ¹²⁾	dV_{CMH} CC	-200	-	200	mV	From common mode voltage
Analog filter settling time	t_{AFSET} CC	-	2	4	μs	If enabled
Modulator recovery time	t_{MREC} CC	-	3.5	5.5	μs	After leaving overdrive state
Modulator settling time ¹³⁾	t_{MSET} CC	-	1	-	μs	After switching on, voltage regulator already running
Spurious Free Dynamic Range ⁷⁾¹⁴⁾	SFDR CC	60	-	-	dB	$V_{CM} = 2.2$ V, DC coupled; $V_{DDM} = \pm 10\%$

- 1) The maximum input range for symmetrical signals (e.g. AC-coupled inputs) depends on the selected internal/external common mode voltage. In this case the Amplitude is limited to $V_{CM} * 2$.
- 2) All modulators must run on the same frequency.
- 3) The calibration sequence must be executed once after an Application Reset
- 4) The total DC error for the uncalibrated case can be calculated by the geometric addition of ED_{GAIN} and ED_{OFF}
- 5) Recalibration needed in case of a temperature change $> 20^\circ C$
- 6) The variation of the impedance between different channels is $< 1.5\%$.
- 7) Derating factors:
 -2 dB in standard-performance mode.
 -3 dB for $CMV = 10_B$, i.e. $V_{CM} = (V_{AREF} \pm 2\%) / 2.0$.
- 8) CIC3, FIR0, FIR1 filters enabled.
- 9) Single-ended mode reduces the SNR by 6 dB if the unused input is grounded, by 3 dB if the unused input connects to V_{CM} (GAIN = 2).
- 10) The defined limits are only valid if the following condition is not applicable: $T_J > 150^\circ C$ and $V_{VAREF} > V_{DDM}$.
- 11) 10 kHz only reachable with 10 MHz modulator clock frequency.
- 12) Voltage V_{CM} is proportional to V_{AREF} , voltage V_{CMH} is proportional to V_{DDM} .
- 13) The modulator needs to settle after being switched on and after leaving the overdrive state.
- 14) $SFDR = 20 * \log(INL / 2^N)$; N = amount of bits

Electrical Specification DSADC Parameters

The following DSADC parameter are valid for $V_{DDM} = 2.97 \text{ V}$ to 4.5 V .

Table 3-30 DSADC_33V

Parameter	Symbol	Values			Unit	Note / Test Condition
		Min.	Typ.	Max.		
Analog input voltage range ¹⁾	V_{DSIN} SR	0	-	3.3	V	single ended
		0	-	6.6	V	differential; $V_{DSxP} - V_{DSxN}$
Reference load current	I_{REF} SR	-	4.5	5.5	μA	per twin-modulator (1 or 2 channels)
Modulator clock frequency ²⁾	f_{MOD} SR	10	-	20	MHz	
Gain error	ED_{GAIN} CC	-1.5	-	1.5 ³⁾	%	Calibrated once
		-10 ⁴⁾	-	10 ⁴⁾	%	Uncalibrated
		-0.3	-	0.3 ⁵⁾	%	calibrated; GAIN = 1; MODCFG.INCFGx=01
DC offset error	ED_{OFF} CC	-5	-	5 ⁵⁾	mV	calibrated
		-50	-	50	mV	calibrated once
		-100 ⁴⁾	0 ⁴⁾	100 ⁴⁾	mV	gain = 1; uncalibrated
Common Mode Rejection Ratio	ED_{CM} CC	200	500	-		
Input impedance ⁶⁾	R_{DAIN} CC	100	130	170	kOhm	Exact value ($\pm 1\%$) available in UCB
Signal-Noise Ratio ^{7) 8) 9) 10)}	SNR CC	45	63	-	dB	$f_{PB} = 100\text{kHz}$; $V_{DDM} = \pm 10\%$; $f_{MOD} = 20 \text{ MHz}$; GAIN = 1
		60	69	-	dB	$f_{PB} = 100\text{kHz}$; $V_{DDM} = \pm 5\%$; $f_{MOD} = 20 \text{ MHz}$; GAIN = 1
		60	68	-	dB	$f_{PB} = 30\text{kHz}$; $V_{DDM} = \pm 10\%$; $f_{MOD} = 20 \text{ MHz}$; GAIN = 1
		69	74	-	dB	$f_{PB} = 30\text{kHz}$; $V_{DDM} = \pm 5\%$; $f_{MOD} = 20 \text{ MHz}$; GAIN = 1
		55	66	-	dB	$f_{PB} = 50\text{kHz}$; $V_{DDM} = \pm 10\%$; $f_{MOD} = 20 \text{ MHz}$; GAIN = 1
		65	72	-	dB	$f_{PB} = 50\text{kHz}$; $V_{DDM} = \pm 5\%$; $f_{MOD} = 20 \text{ MHz}$; GAIN = 1
Pass band	f_{PB} CC	10 ¹¹⁾	-	100	kHz	Output data rate $f_D = f_{PB} * 3$
Pass band ripple ⁸⁾	df_{PB} CC	-1	-	1	%	
Output sampling rate	f_D CC	30	-	330	kHz	
DC compensation factor	DCF CC	-3	-	-	dB	$10^{-5} f_D$

Table 3-30 DSADC_33V (cont'd)

Parameter	Symbol	Values			Unit	Note / Test Condition
		Min.	Typ.	Max.		
Positive reference V_{AREF1} pin leakage	I_{OZ5} CC	-2	-	2	μA	
Negative reference V_{AGND1} pin leakage	I_{OZ6} CC	-3	-	2	μA	
Stop band attenuation ⁸⁾	SBA CC	40	-	-	dB	$0.5 \dots 1 f_D$
		45	-	-	dB	$1 \dots 1.5 f_D$
		50	-	-	dB	$1.5 \dots 2 f_D$
		55	-	-	dB	$2 \dots 2.5 f_D$
		60	-	-	dB	$2.5 \dots \text{OSR}/2 f_D$
Reference ground voltage	V_{AGND} SR	$V_{SSM} - 0.05$	-	$V_{SSM} + 0.05$	V	
Positive reference voltage	V_{AREF} SR	$V_{DDMnom} * 0.9$	-	$V_{DDM} + 0.05$	V	
Common mode voltage accuracy	dV_{CM} CC	-100	-	100	mV	from selected voltage
Common mode hold voltage deviation ¹²⁾	dV_{CMH} CC	-200	-	200	mV	From common mode voltage
Analog filter settling time	t_{AFSET} CC	-	2	4	μs	If enabled
Modulator recovery time	t_{MREC} CC	-	3.5	-	μs	After leaving overdrive state
Modulator settling time ¹³⁾	t_{MSET} CC	-	1	-	μs	After switching on, voltage regulator already running
Spurious Free Dynamic Range ⁷⁾¹⁴⁾	SFDR CC	52	-	-	dB	$V_{CM} = 2.2 \text{ V}$, DC coupled; $V_{DDM} = \pm 10\%$
		60	-	-	dB	$V_{CM} = 2.2 \text{ V}$, DC coupled; $V_{DDM} = \pm 5\%$

- 1) The maximum input range for symmetrical signals (e.g. AC-coupled inputs) depends on the selected internal/external common mode voltage. In this case the Amplitude is limited to $V_{CM} * 2$.
- 2) All modulators must run on the same frequency.
- 3) The calibration sequence must be executed once after an Application Reset
- 4) The total DC error for the uncalibrated case can be calculated by the geometric addition of ED_{GAIN} and ED_{OFF}
- 5) Recalibration needed in case of a temperature change $> 20^\circ\text{C}$.
- 6) The variation of the impedance between different channels is $< 1.5\%$.
- 7) Derating factors:
 -2 dB in standard-performance mode.
 -3 dB for $CMV = 10_B$, i.e. $V_{CM} = (V_{AREF} \pm 2\%) / 2.0$.
- 8) CIC3, FIR0, FIR1 filters enabled.
- 9) Single-ended mode reduces the SNR by 6 dB if the unused input is grounded, by 3 dB if the unused input connects to V_{CM} (GAIN = 2).
- 10) The defined limits are only valid if the following condition is not applicable: $T_J > 150^\circ\text{C}$ and $V_{VAREF} > V_{DDM}$.
- 11) 10 kHz bandwidth only with 10Mhz modulator clock frequency reachable
- 12) Voltage V_{CM} is proportional to V_{AREF} , voltage V_{CMH} is proportional to V_{DDM} .
- 13) The modulator needs to settle after being switched on and after leaving the overdrive state.

14) SFDR = $20 * \log(INL / 2^N)$; N = amount of bits

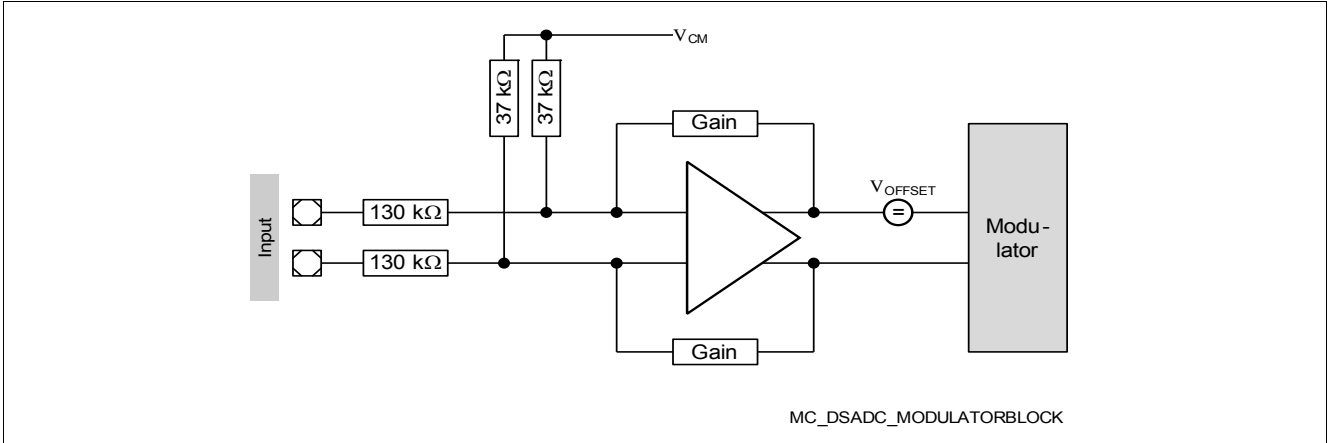

Figure 3-3 DSADC Analog Inputs

3.10 MHz Oscillator

OSC_XTAL is used as accurate and exact clock source. OSC_XTAL supports 8 MHz to 40 MHz crystals external outside of the device. Support of ceramic resonators is also provided.

Table 3-31 OSC_XTAL

Parameter	Symbol	Values			Unit	Note / Test Condition
		Min.	Typ.	Max.		
Input current at XTAL1	I_{IX1} CC	-25	-	25	μA	$V_{IN} > 0\text{V}; V_{IN} < V_{DDP3}\text{V}$
Oscillator frequency	f_{OSC} SR	4	-	40	MHz	Direct Input Mode selected
		8	-	40	MHz	External Crystal Mode selected
Oscillator start-up time ¹⁾	t_{OSCS} CC	-	-	5 ²⁾	ms	
Input high voltage at XTAL1	V_{IHBX} SR	0.8	-	$V_{DDP3} + 0.5$	V	If shaper is bypassed
Input low voltage at XTAL1	V_{ILBX} SR	-0.5	-	0.4	V	If shaper is bypassed
Input voltage at XTAL1	V_{IX} SR	-0.5	-	$V_{DDP3} + 0.5$	V	If shaper is not bypassed
Input amplitude (peak to peak) at XTAL1	V_{PPX} SR	0.3 * V_{DDP3}	-	$V_{DDP3} + 1.0$	V	If shaper is not bypassed; $f_{OSC} > 25\text{MHz}$
		0.4 * V_{DDP3}	-	$V_{DDP3} + 1.0$	V	If shaper is not bypassed; $f_{OSC} \leq 25\text{MHz}$
Internal load capacitor	C_{L0} CC	2	2.35	2.7	pF	
Internal load capacitor	C_{L1} CC	2	2.35	2.7	pF	
Internal load capacitor	C_{L2} CC	3	3.5	4	pF	
Internal load capacitor	C_{L3} CC	5.1	5.9	6.6	pF	

1) t_{OSCS} is defined from the moment when $V_{DDP3} = 3.13\text{V}$ until the oscillations reach an amplitude at XTAL1 of $0.3 * V_{DDP3}$. The external oscillator circuitry must be optimized by the customer and checked for negative resistance as recommended and specified by crystal suppliers.

2) This value depends on the frequency of the used external crystal. For faster crystal frequencies this value decrease.

Note: It is strongly recommended to measure the oscillation allowance (negative resistance) in the final target system (layout) to determine the optimal parameters for the oscillator operation. Please refer to the limits specified by the crystal or ceramic resonator supplier.

3.11 Back-up Clock

The back-up clock provides an alternative clock source.

Table 3-32 Back-up Clock

Parameter	Symbol	Values			Unit	Note / Test Condition
		Min.	Typ.	Max.		
Back-up clock before trimming	f_{BACKUT} CC	75	100	125	MHz	$V_{\text{EXT}} \geq 2.97\text{V}$
Slow speed Back-up clock	f_{BACKSS} CC	75	100	125	kHz	$V_{\text{EXT}} \geq 2.97\text{V}$
Back-up clock after trimming	f_{BACKT} CC	97.5	100	102.5	MHz	$V_{\text{EXT}} \geq 2.97\text{V}$

3.12 Temperature Sensor

Table 3-33 DTS

Parameter	Symbol	Values			Unit	Note / Test Condition
		Min.	Typ.	Max.		
Measurement time	t_M CC	-	-	100	μs	
Calibration reference accuracy	T_{CALACC} CC	-1	-	1	°C	calibration points @ $T_J = -40^\circ\text{C}$ and $T_J = 127^\circ\text{C}$
Non-linearity accuracy over temperature range	T_{NL} CC	-2	-	2	°C	
Temperature sensor range	T_{SR} SR	-40	-	170	°C	
Start-up time after resets inactive	t_{TSST} SR	-	-	20	μs	

The following formula calculates the temperature measured by the DTS in [°C] from the RESULT bit field of the DTSSTAT register.

(3.1)

$$T_J = \frac{DTSSTATRESULT - (607)}{2, 13}$$

3.13 Power Supply Current

The total power supply current defined below consists of leakage and switching component.

Application relevant values are typically lower than those given in the following table and depend on the customer's system operating conditions (e.g. thermal connection or used application configurations).

The operating conditions for the parameters in the following table are:

The real (realistic) power pattern defines the following conditions:

- $T_J = 150\text{ °C}$
- $f_{\text{CPU0}} = 200\text{ MHz}$
- $f_{\text{SRI}} = f_{\text{MAX}} = f_{\text{CPU1}} = f_{\text{CPU2}} = 300\text{ MHz}$
- $f_{\text{SPB}} = f_{\text{STM}} = f_{\text{GTM}} = f_{\text{BAUD1}} = f_{\text{BAUD2}} = f_{\text{ASCLIN}} = 50\text{ MHz}$
- $V_{\text{DD}} = 1.326\text{ V}$
- $V_{\text{DDP3}} = 3.366\text{ V}$
- $V_{\text{EXT / FLEX}} = V_{\text{DDM}} = 5.1\text{ V}$
- all cores are active including one lockstep core
- the following peripherals are inactive: EBU, HSM, HSCT, Ethernet, PSI5, I2C, FCE, MTU, and 50% of the DSADC channels

The max power pattern defines the following conditions:

- $T_J = 150\text{ °C}$
- $f_{\text{CPU0}} = 200\text{ MHz}$
- $f_{\text{SRI}} = f_{\text{MAX}} = f_{\text{CPU1}} = f_{\text{CPU2}} = 300\text{ MHz}$
- $f_{\text{SPB}} = f_{\text{STM}} = f_{\text{GTM}} = f_{\text{BAUD1}} = f_{\text{BAUD2}} = f_{\text{ASCLIN}} = 100\text{ MHz}$
- $V_{\text{DD}} = 1.43\text{ V}$
- $V_{\text{DDP3}} = 3.63\text{ V}$
- $V_{\text{EXT / FLEX}} = V_{\text{DDM}} = 5.5\text{ V}$
- all cores and lockstep cores are active
- all peripherals are active

Table 3-34 Power Supply

Parameter	Symbol	Values			Unit	Note / Test Condition
		Min.	Typ.	Max.		
Σ Sum of I_{DD} 1.3 V core and peripheral supply currents	$I_{DD\ CC}$	-	-	750	mA	max power pattern with $f_{SRI/CPUx} = 270$ MHz with $V_{DD} = 1.3V + 10\%$; valid for Feature Package T, TP, and TC products
		-	-	800	mA	max power pattern with $f_{SRI/CPUx} = 300$ MHz with $V_{DD} = 1.33V + 7.5\%$. valid for Feature Package T, TP, and TC products
		-	-	950	mA	max power pattern. valid for Feature Package TA and TB products
		-	-	930	mA	max power pattern. valid for Feature Package TX and TY products
		-	-	567	mA	real power pattern. valid for Feature Package T, TP, and TC products
		-	-	637	mA	real power pattern. valid for Feature Package TA, TB, TX and TY products
		-	-	-	-	-

Electrical Specification Power Supply Current

Table 3-34 Power Supply (cont'd)

Parameter	Symbol	Values			Unit	Note / Test Condition
		Min.	Typ.	Max.		
I_{DD} core current during active power-on reset (PORST held low)	$I_{DDPORST}$ CC	-	-	140	mA	valid for Feature Package T, TP, and TC products; $T_J=125^\circ\text{C}$
		-	-	220	mA	valid for Feature Package T, TP, and TC products; $T_J=150^\circ\text{C}$
		-	-	176	mA	valid for Feature Package TA, TB, TX, and TY products; $T_J=125^\circ\text{C}$
		-	-	310	mA	valid for Feature Package T, TP, and TC products; $T_J=165^\circ\text{C}$
		-	-	290	mA	valid for Feature Package TA, TB, TX, and TY products; $T_J=150^\circ\text{C}$
		-	-	405	mA	valid for Feature Package TA, TB, TX, and TY products; $T_J=165^\circ\text{C}$
I_{DD} core current of CPU1 main core with CPU1 lockstep core inactive	I_{DDC10} CC	-	-	62	mA	real power pattern
I_{DD} core current of CPU1 main core with lockstep core active	I_{DDC11} CC	-	-	$I_{DDC10} + 48$	mA	real power pattern
I_{DD} core current of CPU2 main core	I_{DDC20} CC	-	-	60	mA	real power pattern
I_{DD} core current added by HSM	I_{DDHSM} CC	-	-	20	mA	HSM running at 100MHz.
I_{DD} core current added by AMU	I_{DDAMU} CC	-	-	48	mA	real power pattern
I_{DD} core current added by FFT	I_{DDFFT} CC	-	-	40	mA	FFT running at 200MHz
Σ Sum of 3.3 V supply currents without pad activity	$I_{DDx3RAIL}$ CC	-	-	104 ¹⁾	mA	real power pattern
I_{DDFL3} Flash memory current	I_{DDFL3} CC	-	-	84 ²⁾	mA	flash read current
		-	-	84 ³⁾	mA	flash read current while programming Dflash

Electrical Specification Power Supply Current

Table 3-34 Power Supply (cont'd)

Parameter	Symbol	Values			Unit	Note / Test Condition
		Min.	Typ.	Max.		
I_{DDP3} supply current without pad activity	I_{DDP3} CC	-	-	29 ²⁾	mA	real power pattern; incl. OSC & flash read current
		-	-	46 ³⁾	mA	incl. OSC and flash programming current
		-	-	46 ⁴⁾	mA	incl. OSC current and flash 3.3V programming current when using external 5V supply
I_{DDP3} supply current for LVDSH pads in LVDS mode	$I_{DDP3LVDSH}$ CC	-	-	16	mA	
Σ Sum of external and ADC supply currents (incl. $I_{EXTFLEX}+I_{DDM}+I_{EXTLVDSM}$)	$I_{EXTRAIL}$ CC	-	-	98	mA	real power pattern
Sum of I_{EXT} and I_{FLEX} supply current without pad activity	$I_{EXT/FLEX}$ CC	-	-	16	mA	real power pattern; PORST output inactive.
I_{EXT} supply current for LVDSM pads in LVDS mode	$I_{EXTLVDSM}$ CC	-	-	20 ⁵⁾	mA	real power pattern
I_{DDM} supply current	I_{DDM} CC	-	-	62	mA	real power pattern; sum of currents of DSADC and VADC modules
		-	-	52	mA	current for DSADC module only; 50% DSADC channels active.
		-	-	100 ⁶⁾	mA	max power pattern; All DSADC channels active 100% time.
		-	-	10	mA	real pattern; current for VADC only
		-	-	20 ⁷⁾	mA	max power pattern; All VADC converters are active 100% time
Σ Sum of all currents (incl. $I_{EXTRAIL}+I_{DDx3RAIL}+I_{DD}$)	I_{DDTOT} CC	-	-	770	mA	real power pattern; valid for Feature Package T, TP, and TC products
		-	-	840	mA	real power pattern; valid for Feature Package TA, TB, TX, and TY products

Electrical Specification Power Supply Current

Table 3-34 Power Supply (cont'd)

Parameter	Symbol	Values			Unit	Note / Test Condition
		Min.	Typ.	Max.		
Σ Sum of all currents with DC-DC EVR13 regulator active ⁸⁾	$I_{DDTOTDC3}$ CC	-	-	460	mA	real power pattern; $V_{EXT} = 3.3V$
Σ Sum of all currents with DC-DC EVR13 regulator active ⁸⁾	$I_{DDTOTDC5}$ CC	-	-	370	mA	real power pattern; $V_{EXT} = 5V$
Σ Sum of all currents (STANDBY mode)	I_{EVRSB} CC	-	-	150 ⁹⁾	μA	Standby RAM is active. Power to remaining domains switched off. $T_J = 25^\circ C$; $V_{EVRSB} = 5V$
Σ Sum of all currents (SLEEP mode)	I_{SLEEP} CC	-	-	24	mA	All CPUs in idle, All peripherals in sleep, $f_{SRI/SPB} = 1 MHz$ via LPDIV divider; $T_J = 25^\circ C$; valid for Feature Package T, TP, and TC products
		-	-	26	mA	All CPUs in idle, All peripherals in sleep, $f_{SRI/SPB} = 1 MHz$ via LPDIV divider; $T_J = 25^\circ C$; valid for Feature Package TA, TB, TX, and TY products
Maximum power dissipation	PD CC	-	-	2382	mW	max power pattern ; valid for Feature Package TA and TB products
		-	-	2140	mW	max power pattern. valid for Feature Package T, TP, and TC products
		-	-	2350	mW	max power pattern. valid for Feature Package TX and TY products
		-	-	1600	mW	real power pattern. valid for Feature Package T, TP, and TC products
		-	-	1700	mW	real power pattern. valid for Feature Package TA, TB, TX, and TY products

1) In case EVR33 is not used, Injection current into 3.3V VDDP3 supply rail with active sink on 5V VEXT rail should be limited to 500 mA if during power sequencing 3.3V is supplied before 5V by external regulator.

- 2) Realistic Pflash read pattern with 70% Pflash bandwidth utilization and a code mix of 50% 0s and 50% 1s. A common decoupling capacitor of atleast 100nF for ($V_{DDFL3} + V_{DDP3}$) is used. Dflash read current is also included. Flash read current is predominantly drawn from V_{DDFL3} pin and a minor part drawn from the neighbouring V_{DDP3} pin.
- 3) Continuous Dflash programming in burst mode with 3.3 V supply and realistic Pflash read access in parallel. Erase currents of the corresponding flash modules are less than the respective programming currents at V_{DDP3} pin. Programming and erasing flash may generate transient current spikes of up to x mA for maximum x us which is handled by the decoupling and buffer capacitors. This parameter is relevant for external power supply dimensioning and not for thermal considerations.
- 4) In addition to the current specified, upto 4 mA is additionally drawn at V_{EXT} supply in burst programming mode with 5V external supply. Erase currents of the corresponding flash modules are less than the respective programming currents at V_{DDP3} supply. This parameter is relevant for external power supply dimensioning and not for thermal considerations.
- 5) The current consumption is for 2 pairs of LVDSM differential pads (8 pins). A single pair of LVDSM differential pads (4 pins) consumes 7 mA.
- 6) The current consumption is for 6 DS channels with standard performance (MCFG=11b). A single DS channel instance consumes 6-8 mA.
- 7) A single converter instance of VADC unit consumes 2 mA.
- 8) The total current drawn from external regulator is estimated with 72% EVR13 SMPS regulator Efficiency. $I_{DDTOTDC}$ is calculated from I_{DDTOT} using the scaled core current $[(I_{DD} \times V_{DD}) / (V_{in} \times \text{Efficiency})]$ and constitutes all other rail currents and I_{DDM} .
- 9) Σ Sum of all currents during RUN mode at $V_{EVR SB}$ supply pin is less than (8 mA + ISCRSB) . It is recommended to have atleast 100 nF decoupling capacitor at this pin.

3.13.1 Calculating the 1.3 V Current Consumption

The current consumption of the 1.3 V rail compose out of two parts:

- Static current consumption
- Dynamic current consumption

The static current consumption is related to the device temperature T_J and the dynamic current consumption depends of the configured clocking frequencies and the software application executed. These two parts needs to be added in order to get the rail current consumption.

Valid for Feature Package T, TP, and TC products:

$$I_0 = 0,894 \left[\frac{\text{mA}}{\text{C}} \right] \times e^{0,0289 \times T_J[\text{C}]} \quad (3.2)$$

$$I_0 = 4,319 \left[\frac{\text{mA}}{\text{C}} \right] \times e^{0,0259 \times T_J[\text{C}]} \quad (3.3)$$

Valid for Feature Package TA, TB, TX, and TY products:

$$I_0 = 2,731 \left[\frac{\text{mA}}{\text{C}} \right] \times e^{0,0244 \times T_J[\text{C}]} \quad (3.4)$$

$$I_0 = 5,832 \left[\frac{\text{mA}}{\text{C}} \right] \times e^{0,0257 \times T_J[\text{C}]} \quad (3.5)$$

Function 2 / 4 defines the typical static current consumption and Function 3 / 5 defines the maximum static current consumption. Both functions are valid for $V_{DD} = 1.326 \text{ V}$.

3.14 Power-up and Power-down

3.14.1 External Supply Mode

5 V & 1.3 V supplies are externally supplied. 3.3V is generated internally by EVR33.

- External supplies VEXT and VDD may ramp-up or ramp-down independent of each other with regards to start, rise and fall time(s). Voltage Ramp-up from a residual threshold (Eg : up to 1 V) should also lead to a normal startup of the device.
- The rate at which current is drawn from the external regulator (dI_{EXT}/dt or dI_{DD}/dt) is limited in the Start-up phase to a maximum of 50 mA/100 us.
- PORST is active/asserted when either PORST (input) or PORST (output) is active/asserted.
- PORST (input) active means that the reset is held active by external agents by pulling the PORST pin low. It is recommended to keep the PORST (input) asserted until all the external supplies are above their primary reset thresholds.
- PORST (output) active means that μC asserts the reset internally and drives the PORST pin low thus propagating the reset to external devices. The PORST (output) is asserted by the μC when atleast one among the three supply domains (1.3 V, 3.3 V or 5 V) violate their primary under-voltage reset thresholds. The PORST (output) is deasserted by the μC when all supplies are above their primary reset thresholds and the basic supply and clock infrastructure is available.
- The power sequence as shown in [Figure 3-4](#) is enumerated below
 - T1 refers to the point in time when basic supply and clock infrastructure is available as the external supplies ramp up. The supply mode is evaluated based on the HWCFG [0:2] pins and consequently a soft start of EVR33 regulator is initiated.
 - T2 refers to the point in time when all supplies are above their primary reset thresholds. EVR33 regulator has ramped up. PORST (output) is deasserted and HWCFG [0:7] pins are latched on PORST rising edge. Firmware execution is initiated.
 - T3 refers to the point in time when Firmware execution is completed. User code execution starts with a default frequency of 100 MHz.
 - T4 refers to the point in time during the Ramp-down phase when atleast one of the externally provided or generated supplies (1.3 V, 3.3 V or 5 V) drop below their respective primary under-voltage reset thresholds.

Please note that there is no special requirements for \overline{PORST} slew rates.

Electrical Specification Power-up and Power-down

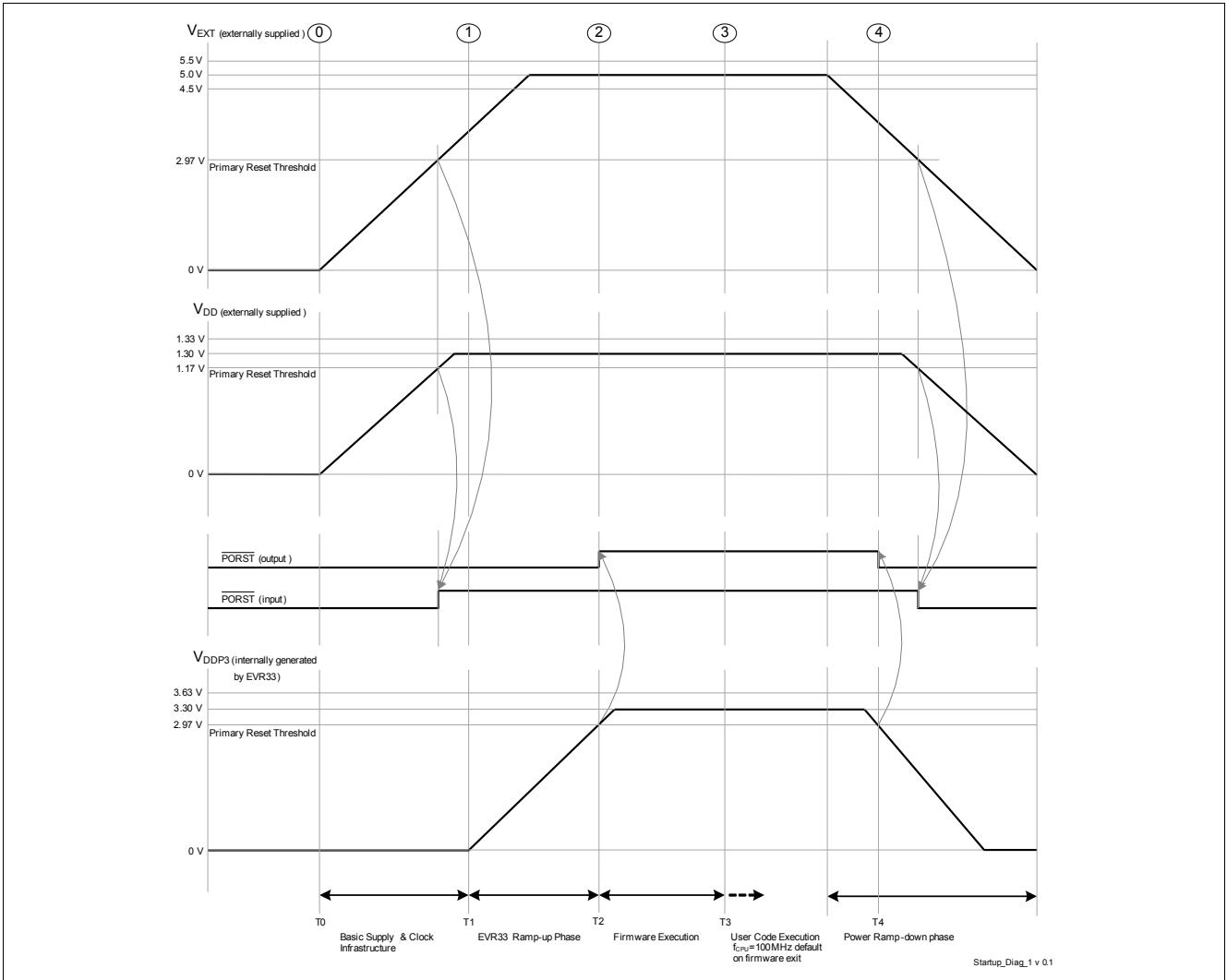

Figure 3-4 External Supply Mode - 5 V and 1.3 V externally supplied

3.14.2 Single Supply Mode

5 V single supply mode. 1.3 V & 3.3 V are generated internally by EVR13 & EVR33.

- The rate at which current is drawn from the external regulator (dI_{EXT}/dt) is limited in the Start-up phase to a maximum of 50 mA/100 μ s.
- PORST is active/asserted when either PORST (input) or PORST (output) is active/asserted.
- PORST (input) active means that the reset is held active by external agents by pulling the PORST pin low. It is recommended to keep the PORST (input) asserted until the external supply is above the respective primary reset threshold.
- PORST (output) active means that μ C asserts the reset internally and drives the PORST pin low thus propagating the reset to external devices. The PORST (output) is asserted by the μ C when at least one among the three supply domains (1.3 V, 3.3 V or 5 V) violate their primary under-voltage reset thresholds. The PORST (output) is deasserted by the μ C when all supplies are above their primary reset thresholds and the basic supply and clock infrastructure is available.
- The power sequence as shown in [Figure 3-5](#) is enumerated below
 - T1 refers to the point in time when basic supply and clock infrastructure is available as the external supply ramps up. The supply mode is evaluated based on the HWCFG [0:2] pins and consequently a soft start of EVR13 and EVR33 regulators are initiated.
 - T2 refers to the point in time when all supplies are above their primary reset thresholds. EVR13 and EVR33 regulators have ramped up. PORST (output) is deasserted and HWCFG [0:7] pins are latched on PORST rising edge. Firmware execution is initiated.
 - T3 refers to the point in time when Firmware execution is completed. User code execution starts with a default frequency of 100 MHz.
 - T4 refers to the point in time during the Ramp-down phase when at least one of the externally provided or generated supplies (1.3 V, 3.3 V or 5 V) drop below their respective primary under-voltage reset thresholds.

Please note that there is no special requirements for $\overline{\text{PORST}}$ slew rates.

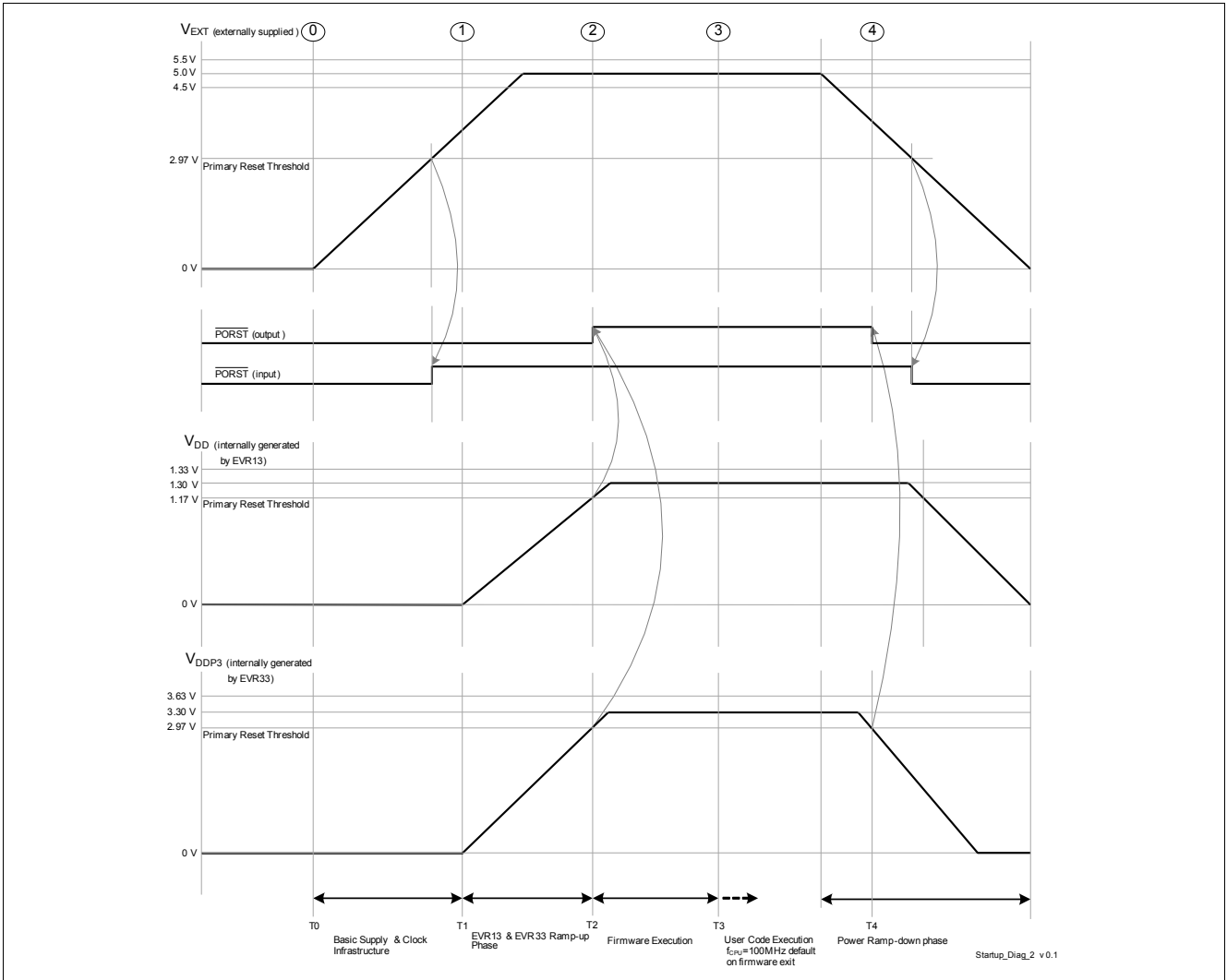

Figure 3-5 Single Supply Mode - 5 V single supply

3.14.3 External Supply Mode

All supplies, namely 5 V, 3.3 V & 1.3 V, are externally supplied.

- External supplies VEXT, VDDP3 & VDD may ramp-up or ramp-down independent of each other with regards to start, rise and fall time(s).
- The rate at which current is drawn from the external regulator (dI_{EXT}/dt , dI_{DD}/dt or dI_{DDP3}/dt) is limited in the Start-up phase to a maximum of 50 mA/100 us.
- PORST is active/asserted when either PORST (input) or PORST (output) is active/asserted.
- PORST (input) active means that the reset is held active by external agents by pulling the PORST pin low. It is recommended to keep the PORST (input) asserted until all the external supplies are above their primary reset thresholds.
- PORST (output) active means that μC asserts the reset internally and drives the PORST pin low thus propagating the reset to external devices. The PORST (output) is asserted by the μC when at least one among the three supply domains (1.3 V, 3.3 V or 5 V) violate their primary under-voltage reset thresholds. The PORST (output) is deasserted by the μC when all supplies are above their primary reset thresholds and the basic supply and clock infrastructure is available.
- The power sequence as shown in [Figure 3-6](#) is enumerated below
 - T1 refers to the point in time when all supplies are above their primary reset thresholds and basic clock infrastructure is available. The supply mode is evaluated based on the HWCFG [0:2] pins. PORST (output) is deasserted and HWCFG [0:7] pins are latched on PORST rising edge. Firmware execution is initiated.
 - T2 refers to the point in time when Firmware execution is completed. User code execution starts with a default frequency of 100 MHz.
 - T3 refers to the point in time during the Ramp-down phase when at least one of the externally provided supplies (1.3 V, 3.3 V or 5 V) drop below their respective primary under-voltage reset thresholds.

Please note that there is no special requirements for \overline{PORST} slew rates.

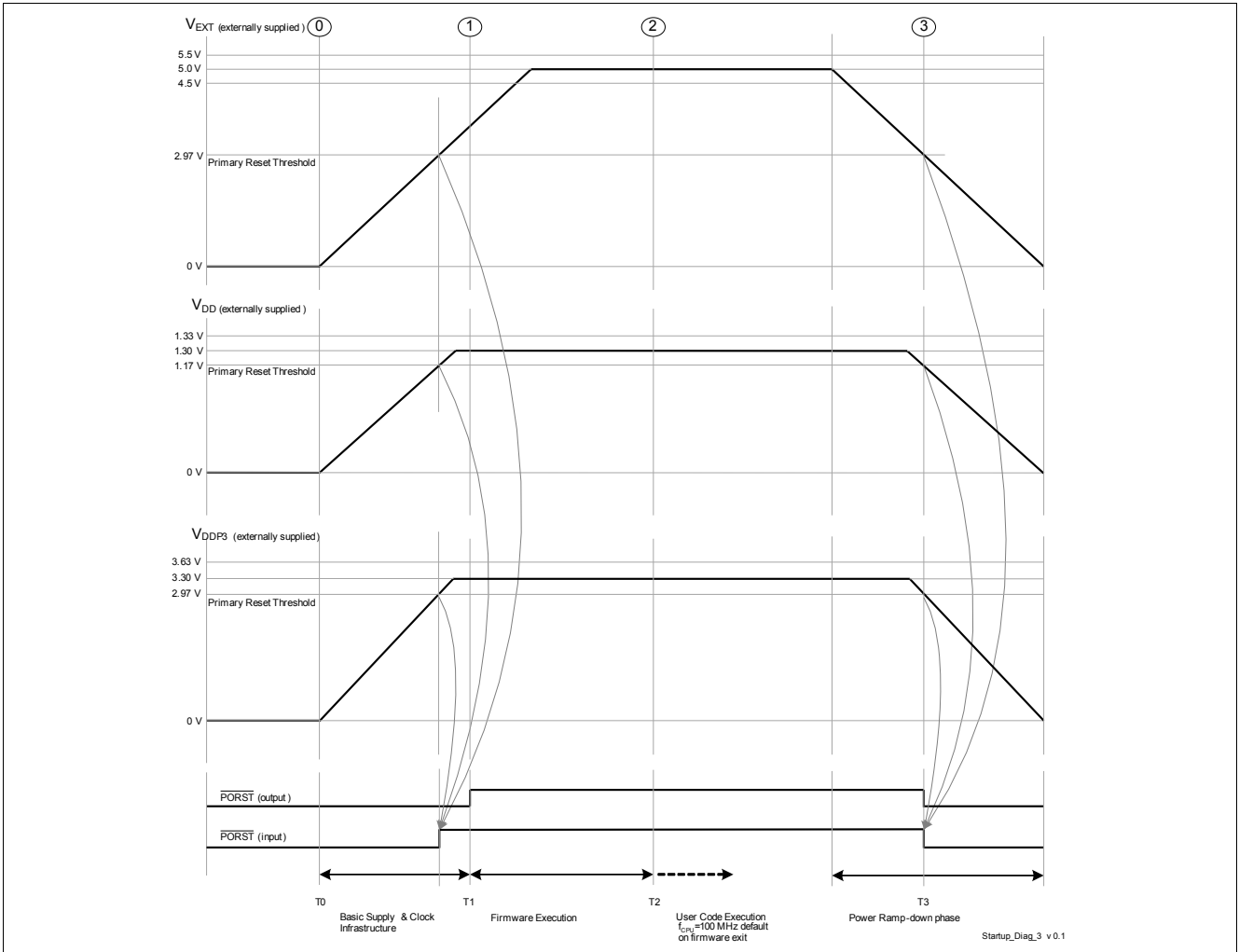

Figure 3-6 External Supply Mode - 5 V, 3.3 V & 1.3 V externally supplied

3.14.4 Single Supply Mode

3.3 V single supply mode. 1.3 V is generated internally by EVR13.

- The rate at which current is drawn from the external regulator (dI_{EXT}/dt) is limited in the Start-up phase to a maximum of 50 mA/100 μ s.
- PORST is active/asserted when either PORST (input) or PORST (output) is active/asserted.
- PORST (input) active means that the reset is held active by external agents by pulling the PORST pin low. It is recommended to keep the PORST (input) asserted until the external supply is above the respective primary reset threshold.
- PORST (output) active means that μ C asserts the reset internally and drives the PORST pin low thus propagating the reset to external devices. The PORST (output) is asserted by the μ C when at least one among the three supply domains (1.3 V or 3.3 V) violate their primary under-voltage reset thresholds. The PORST (output) is deasserted by the μ C when all supplies are above their primary reset thresholds and the basic supply and clock infrastructure is available.
- The power sequence as shown in [Figure 3-7](#) is enumerated below
 - T1 refers to the point in time when basic supply and clock infrastructure is available as the external supply ramps up. The supply mode is evaluated based on the HWCFG [0:2] pins and consequently a soft start of EVR13 regulator is initiated.
 - T2 refers to the point in time when all supplies are above their primary reset thresholds. EVR13 regulator has ramped up. PORST (output) is deasserted and HWCFG [0:7] pins are latched on PORST rising edge. Firmware execution is initiated.
 - T3 refers to the point in time when Firmware execution is completed. User code execution starts with a default frequency of 100 MHz.
 - T4 refers to the point in time during the Ramp-down phase when at least one of the externally provided or generated supplies (1.3 V or 3.3 V) drop below their respective primary under-voltage reset thresholds.

Please note that there is no special requirements for \overline{PORST} slew rates.

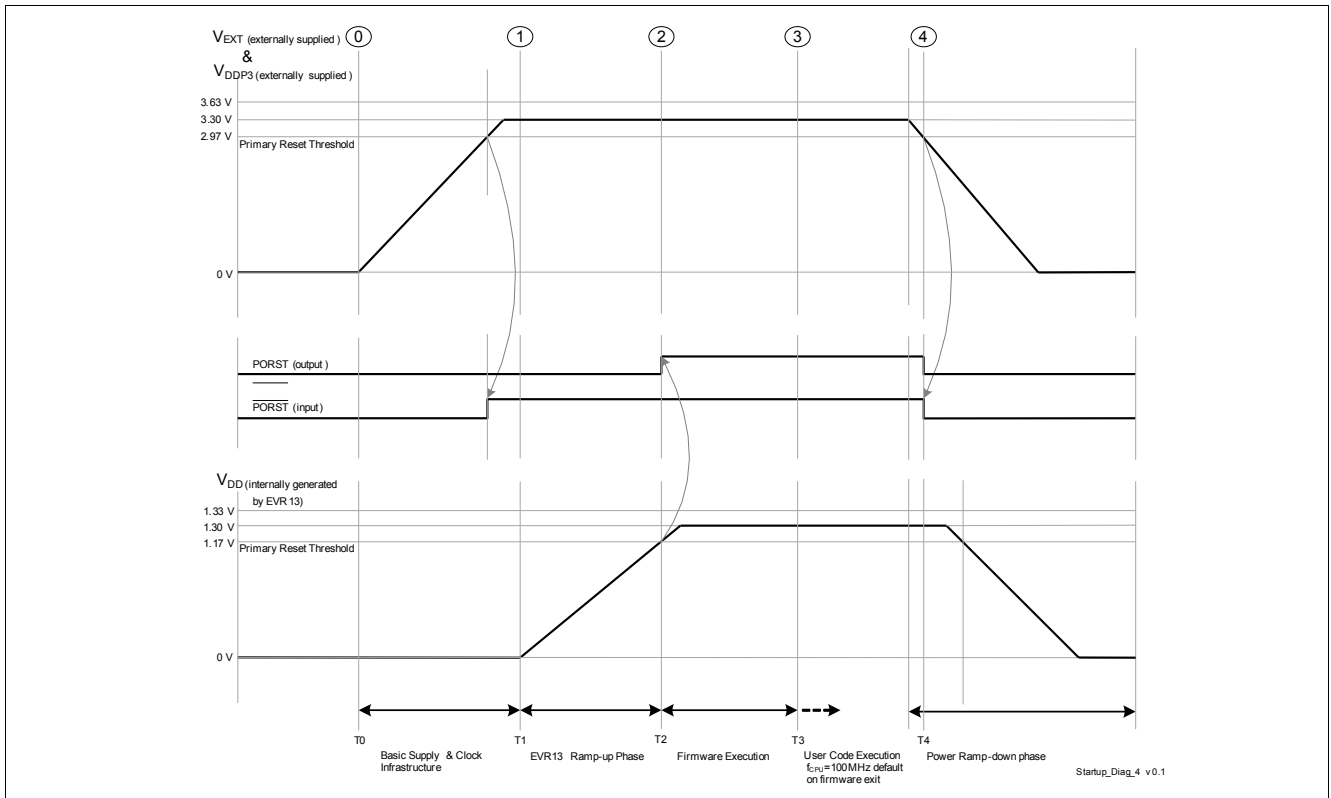

Figure 3-7 Single Supply Mode - 3.3 V single supply

3.15 Reset Timing

Table 3-35 Reset Timings

Parameter	Symbol	Values			Unit	Note / Test Condition
		Min.	Typ.	Max.		
Application Reset Boot Time ¹⁾	t_B CC	-	-	350 ²⁾	μ s	operating with max. frequencies.
System Reset Boot Time	t_{BS} CC	-	-	1	ms	
Power on Reset Boot Time ³⁾	t_{BP} CC	-	-	2.5 ²⁾	ms	$dV/dT=1V/ms$. including EVR ramp-up and Firmware execution time
		-	-	1.11 ²⁾	ms	Firmware execution time; without EVR operation (external supply only)
Minimum PORST hold time incase of power fail event issued by EVR primary monitor	t_{EVRPOR} CC	10	-	-	μ s	
EVR start-up or ramp-up time	$t_{EVRstartup}$ CC	-	-	1	ms	$dV/dT=1V/ms$. EVR13 and EVR33 active
Minimum PORST active hold time after power supplies are stable at operating levels ⁴⁾	t_{POA} CC	1	-	-	ms	
Configurable PORST digital filter delay in addition to analog pad filter delay	$t_{PORSTDF}$ CC	600	-	1200	ns	
HWCFG pins hold time from ESR0 rising edge	t_{HDH} CC	$16 / f_{SPB}$	-	-	ns	
HWCFG pins setup time to ESR0 rising edge	t_{HDS} CC	0	-	-	ns	
Ports inactive after ESR0 reset active	t_{PI} CC	-	-	$8/f_{SPB}$	ns	
Ports inactive after PORST reset active ⁵⁾	t_{PIP} CC	-	-	150	ns	
Hold time from PORST rising edge	t_{POH} SR	150	-	-	ns	
Setup time to PORST rising edge	t_{POS} SR	0	-	-	ns	

1) The duration of the boot time is defined between the rising edge of the internal application reset and the clock cycle when the first user instruction has entered the CPU pipeline and its processing starts.

2) The timing values assumes programmed BMI with ESR0CNT inactive.

3) The duration of the boot time is defined by all external supply voltages are inside there operation condicions and the clock cycle when the first user instruction has entered the CPU pipeline and its processing starts.

Electrical Specification Reset Timing

- 4) The regulator that supplies V_{EXT} should ensure that V_{EXT} is in the operational region before PORST is externally released by the regulator. In case of 5V nominal supply, it should be ensured that $V_{EXT} > 4V$ before PORST is released. In case of 3.3V nominal supply, it should be ensured that $V_{EXT} > 3V$ before PORST is released. The additional minimum PORST hold time is required as an additional mechanism to avoid consecutive PORST toggling owing to slow supply slopes or residual supply ramp-ups. It is also required to activate external PORST at least 100us before power-fail is recognised to avoid consecutive PORST toggling on a power fail event.
- 5) This parameter includes the delay of the analog spike filter in the \overline{PORST} pad.

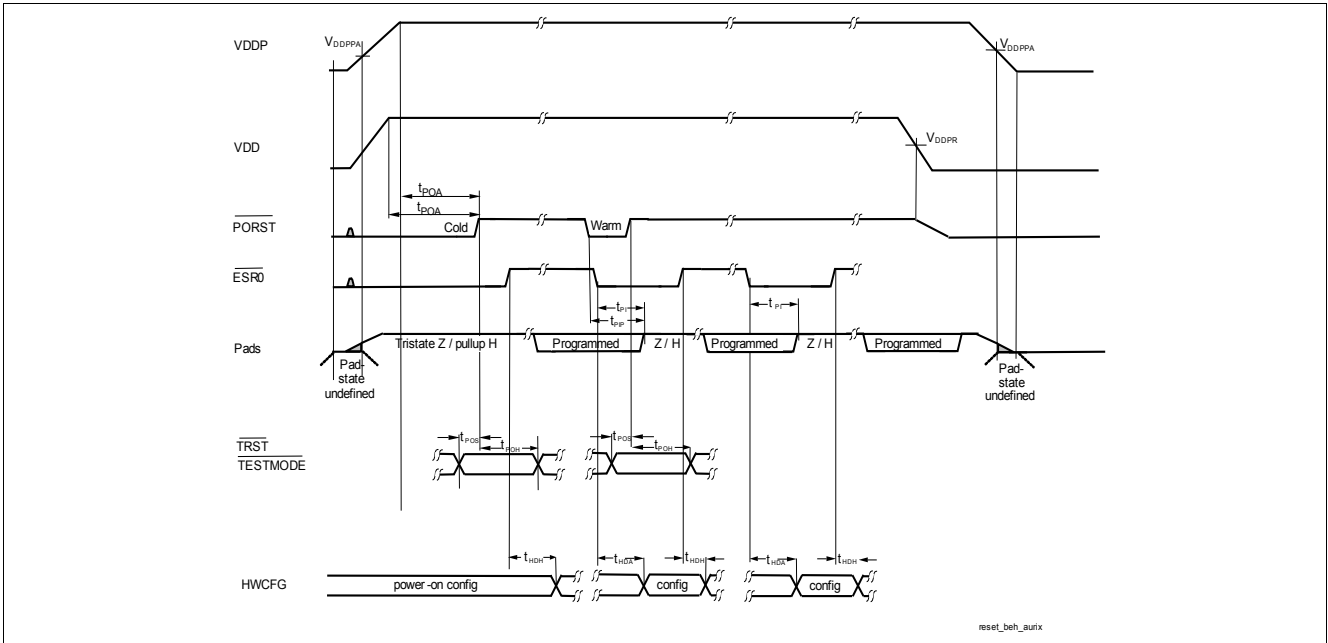

Figure 3-8 Power, Pad and Reset Timing

3.16 EVR

Table 3-36 3.3V

Parameter	Symbol	Values			Unit	Note / Test Condition
		Min.	Typ.	Max.		
Input voltage range ¹⁾	V_{IN} SR	-	-	5.50	V	pass device=off chip
		4	-	5.50	V	pass device=on chip
Output voltage operational range including load/line regulation and aging incase of LDO regulator	V_{OUT} CC	2.97	3.3	3.63	V	pass device=off chip
		2.97	3.3	3.63	V	pass device=on chip
Output V_{DDx3} static voltage accuracy after trimming and aging without dynamic load/line Regulation incase of LDO regulator.	V_{OUTT} CC	3.225	3.3	3.375	V	pass device=off chip
		3.225	3.3	3.375	V	pass device=on chip
Output buffer capacitance on V_{OUT} ²⁾	C_{OUT} CC	-	2.2	-	μ F	pass device=off chip
		-	2.2	-	μ F	pass device=on chip
Primary Undervoltage Reset threshold for V_{DDx3} ³⁾	V_{RST33} CC	-	-	3.0	V	by reset release before EVR trimming on supply ramp-up.
Startup time	t_{STR} CC	-	-	1000	μ s	pass device=off chip
		-	-	1000	μ s	pass device=on chip
External V_{IN} supply ramp ⁴⁾	dV_{in}/dT SR	-	1	50	V/ms	pass device=off chip
		-	1	50	V/ms	pass device=on chip
Load step response	dV_{out}/dI_{out} CC	-	-	240	mV	$dI=-100mA$; $T_{settle}=20\mu s$; pass device=off chip
		-	-	240	mV	$dI=-70mA/20ns$; $T_{settle}=20\mu s$; pass device=on chip
		-240	-	-	mV	$dI=100mA$; $T_{settle}=20\mu s$; pass device=off chip
		-240	-	-	mV	$dI=50mA/20ns$; $T_{settle}=20\mu s$; pass device=on chip
Line step response	dV_{out}/dV_{in} CC	-20	-	20	mV	$dV/dT=1V/ms$; pass device=off chip
		-20	-	20	mV	$dV/dT=1V/ms$; pass device=on chip

1) A maximum pass device dropout voltage of 700mV is included in the minimum input voltage to ensure optimal pass device operation.

Electrical SpecificationEVR

- 2) It is recommended to select a capacitor with ESR less than 50 mOhm (0.5MHz - 10 MHz). It is also recommended that the resistance of the supply trace from the pin to the EVR output capacitor is less than 100 mOhm.
- 3) The reset release on supply ramp-up is delayed by a time duration 20-40 us after reaching undervoltage reset threshold. This serves as a time hysteresis to avoid multiple consecutive cold PORST events during slow supply ramp-ups owing to voltage drop/current jumps when reset is released. The reset limit of 2,97V at pin is for the case with 3.3V generated internally from EVR33. In case the 3.3V supply is provided externally, the bondwire drop will cause a reset at a higher voltage of 3.0V at the V_{DDP3} pin.
- 4) EVR robust against residual voltage ramp-up starting between 0-1 V.

Table 3-37 1.3V

Parameter	Symbol	Values			Unit	Note / Test Condition
		Min.	Typ.	Max.		
Input voltage range ¹⁾	V_{IN} SR	2.97	-	5.5	V	pass device=off chip
Output voltage operational range including load/line regulation and aging incase of LDO regulator	V_{OUT} CC	1.17	1.3	1.43	V	pass device=off chip
Output V_{DD} static voltage accuracy after trimming without dynamic load/line regulation with aging incase of LDO regulator.	V_{OUTT} CC	1.275	1.3	1.325	V	pass device=off chip
Output buffer capacitance on V_{OUT} ²⁾	C_{OUT} CC	3	4.7	6.3	μ F	pass device=off chip
Primary undervoltage reset threshold for V_{DD} ³⁾	V_{RST13} CC	-	-	1.17	V	by reset release before EVR trimming on supply ramp-up. pass device=off chip
Startup time	t_{STR} CC	-	-	1000	μ s	pass device=off chip
External V_{IN} supply ramp ⁴⁾	dV_{in}/dT SR	-	1	50	V/ms	pass device=off chip
Load step response	dV_{out}/dI_{out} CC	-	-	100	mV	$dI=-150mA$; $T_{settle}=20\mu s$; pass device=off chip
		-100	-	-	mV	$dI=100mA$; $T_{settle}=20\mu s$; pass device=off chip
Line step response	dV_{out}/dV_{in} CC	-10	-	10	mV	$dV/dT=1V/ms$; pass device=off chip

- 1) A maximum pass device dropout voltage of 700mV is included in the minimum input voltage to ensure optimal pass device operation.
- 2) It is recommended to select a capacitor with ESR less than 50 mOhm (0.5MHz - 10 MHz). It is also recommended that the resistance of the supply trace from the pin to the EVR output capacitor is less than 100 mOhm.
- 3) The reset release on supply ramp-up is delayed by a time duration 30-60 μ s after reaching undervoltage reset threshold. This serves as a time hysteresis to avoid multiple consecutive cold PORST events during slow supply ramp-ups owing to voltage drop/current jumps when reset is released. The reset limit of 1,17V at pin is for the case with 1.3V generated internally from EVR13. In case the 1.3V supply is provided externally, the bondwire drop will cause a reset at a higher voltage of 1.18V at the VDD pin.
- 4) EVR robust against residual voltage ramp-up starting between 0-1 V.

Table 3-38 Supply Monitoring

Parameter	Symbol	Values			Unit	Note / Test Condition
		Min.	Typ.	Max.		
V_{EXT} primary undervoltage monitor accuracy after trimming ¹⁾	$V_{EXTPRIUV}$ SR	2.86	2.92	2.97	V	V_{EXT} = Undervoltage Reset Threshold
V_{DDP3} primary undervoltage monitor accuracy after trimming ¹⁾	$V_{DDP3PRIUV}$ SR	2.86	2.90	2.97	V	V_{DDP3} = Undervoltage Reset Threshold
V_{DD} primary undervoltage monitor accuracy after trimming ¹⁾	$V_{DDPRIUV}$ SR	1.13	1.15	1.17	V	V_{DD} = Undervoltage Reset Threshold
V_{EXT} secondary supply monitor accuracy	V_{EXTMON} CC	4.9	5.0	5.1	V	SWDxxVAL V_{EXT} monitoring threshold=5V=DA _h
V_{DDP3} secondary supply monitor accuracy	$V_{DDP3MON}$ CC	3.23	3.30	3.37	V	EVR33xxVAL V_{DDP3} monitoring threshold=3.3V=90 _h
V_{DD} secondary supply monitor accuracy	V_{DDMON} CC	1.27	1.30	1.33	V	EVR13xxVAL V_{DD} monitoring threshold=1.3V=DF _h
EVR primary and secondary monitor measurement latency for a new supply value	$t_{EVROMON}$ CC	-	-	1.8	μs	

1) The monitor tolerances constitute the inherent variation of the bandgap and ADC over process, voltage and temperature operational ranges. The xxxPRIUV parameters are device individually tested in production with ±1% tolerance about the min and max xxxPRIUV limits. In TQFP100 and QFP80 pin packages, VDDPRIUV is not tested as HWCFG2 pin is absent.

Table 3-39 EVR13 SMPS External components

Parameter	Symbol	Values			Unit	Note / Test Condition
		Min.	Typ.	Max.		
External output capacitor value ¹⁾	C_{OUTDC} SR	15.4	22	29.7	μF	$I_{DDDC}=1A$
		6.5	10	13.5	μF	$I_{DDDC}=400mA$
External output capacitor ESR	C_{DC_ESR} SR	-	-	50	mOhm	$f \geq 0.5MHz; f \leq 10MHz$
		-	-	100	Ohm	$f=10Hz$
External input capacitor value ¹⁾	C_{IN} SR	6.5	10	13.5	μF	$I_{DDDC}=1A$
		4.42	6.8	9.18	μF	$I_{DDDC}=400mA$
External input capacitor ESR	C_{IN_ESR} SR	-	-	50	mOhm	$f \geq 0.5MHz; f \leq 10MHz$
		-	-	100	Ohm	$f=100Hz$
External inductor value ²⁾	L_{DC} SR	2.31	3.3	4.29	μH	$f_{DCDC}=1.5MHz$
		3.29	4.7	6.11	μH	$f_{DCDC}=1MHz$
External inductor ESR	L_{DC_ESR} SR	-	-	0.2	Ohm	
P + N-channel MOSFET logic level	V_{LL} SR	-	-	2.5	V	

Table 3-39 EVR13 SMPS External components (cont'd)

Parameter	Symbol	Values			Unit	Note / Test Condition
		Min.	Typ.	Max.		
P + N-channel MOSFET drain source breakdown voltage	$ V_{BR_DS} $ SR	-	-	7	V	
P + N-channel MOSFET drain source ON-state resistance	R_{ON} SR	-	-	150	mOhm	$I_{DDDC}=1A; V_{GS}=2.5V;$ $T_A=25^\circ C$
		-	-	200	mOhm	$I_{DDDC}=400mA; V_{GS}=2.5V;$ $T_A=25^\circ C$
P + N-channel MOSFET Gate Charge	Q_{ac} SR	-	4	-	nC	$I_{DDDC}=1A; MOS-$ $V_{GS}=5V$
		-	8	-	nC	$I_{DDDC}=400mA; MOS-$ $V_{GS}=5V$
External MOSFET commutation time	t_c SR	10	30	40	ns	configurable
N-channel MOSFET reverse diode forward voltage	V_{RDN} SR	-	0.8	-	V	

1) Capacitor min-max range represent typical $\pm 35\%$ tolerance including DC bias effect. The trace resistance from the capacitor to the supply or ground rail should be limited to 25 mOhm.

2) External inductor min-max range represent typical $\pm 30\%$ tolerance at a DC bias current of 100mA.

Table 3-40 EVR13 SMPS

Parameter	Symbol	Values			Unit	Note / Test Condition
		Min.	Typ.	Max.		
Input V_{DDP3} voltage range	V_{IN} CC	2.97	-	3.63	V	
Input V_{EXT} Voltage range	V_{IN} SR	2.97	-	5.5	V	
SMPS regulator output voltage range including load/line regulation and aging ¹⁾	V_{DDDC} CC	1.17	-	1.43	V	$V_{DD} \geq 2.97V; V_{DD} \leq 5.5V;$ $I_{DDDC} \geq 1mA; I_{DDDC} \leq 1A$
SMPS regulator static voltage output accuracy after trimming without dynamic load/line Regulation with aging. ²⁾	V_{DDDC} CC	1.275	1.3	1.325	V	$V_{DD} \geq 2.97V; V_{DD} \leq 5.5V;$ $I_{DDDC} \geq 1mA; I_{DDDC} \leq 1A$
Programmable switching frequency	f_{DCDC} CC	0.4	-	2.0	MHz	
Switching frequency modulation spread	Δf_{DCSPR} CC	-	-	2%	MHz	
Maximum ripple at I_{MAX} (peak-to-peak) ³⁾	ΔV_{DDDC} CC	-	-	15	mV	$V_{DD} \geq 2.97V; V_{DD} \leq 5.5V;$ $I_{DDDC} \geq 300mA;$ $I_{DDDC} \leq 1A$
No load current consumption of SMPS regulator	I_{DCNL} CC	-	5	10	mA	$f_{DCDC}=1MHz$

Table 3-40 EVR13 SMPS (cont'd)

Parameter	Symbol	Values			Unit	Note / Test Condition
		Min.	Typ.	Max.		
SMPS regulator load transient response	dV_{out}/dI_{out} CC	-25	-	25	mV	$dI < 200mA$; $f_{DCDC}=1MHz$; $t_f=0.1\mu s$; $t_f=0.1\mu s$; $V_{DDDC}=1.3V$
		-65	-	65	mV	$dI < 400mA$; $f_{DCDC}=1MHz$; $t_f=0.1\mu s$; $t_f=0.1\mu s$; $V_{DDDC}=1.3V$
		-130	-	130	mV	$dI < 700mA$; $f_{DCDC}=1MHz$; $t_f=0.1\mu s$; $t_f=0.1\mu s$; $V_{DDDC}=1.3V$
Maximum output current of the regulator	I_{MAX} SR	-	-	1	A	limited by thermal constraints and component choice
SMPS regulator efficiency	η_{DC} CC	-	85	-	%	$V_{IN}=3.3V$; $I_{DDDC}=300mA$; $f_{DCDC}=1MHz$.
		-	75	-	%	$V_{IN}=5V$; $I_{DDDC}=400mA$; $f_{DCDC}=1.5MHz$
		-	80	-	%	$V_{IN}=5V$; $I_{DDDC}=400mA$; $f_{DCDC}=1MHz$.

- 1) In case of SMPS mode, it shall be ensured that the V_{DD} output pin shall be connected on PCB level to all other V_{DD} Input pins.
- 2) In case of f_{SRI} running with max frequency, it shall be ensured that the V_{DD} operating range is limited to 1.235V upto 1.430V. The DCDC may be configured in this case with a nominal voltage of $1.33V \pm 7.5\%$. The static accuracy and regulation parameter ranges remain also valid for this case.
- 3) If frequency spreading (SDFREQSPRD = 1) is activated, an additional ripple of 1% need to be considered.

3.17 Phase Locked Loop (PLL)

Table 3-41 PLL

Parameter	Symbol	Values			Unit	Note / Test Condition
		Min.	Typ.	Max.		
PLL base frequency	f_{PLLBASE} CC	80	150	360	MHz	
VCO frequency range	f_{VCO} SR	400	-	800	MHz	
VCO Input frequency range	f_{REF} CC	8	-	24	MHz	
Modulation Amplitude	MA CC	0	-	2	%	
Peak Period jitter	DP CC	-200	-	200	ps	
Peak Accumulated Jitter	D_{PP} CC	-5	-	5	ns	without modulation
Total long term jitter	J_{TOT} CC	-	-	11.5	ns	including modulation; MA ≤ 1%
System frequency deviation	f_{SYSD} CC	-	-	0.01	%	with active modulation
Modulation variation frequency	f_{MV} CC	2	3.6	5.4	MHz	
PLL lock-in time	t_{L} CC	11.5	-	200	μs	

Note: The specified PLL jitter values are valid if the capacitive load per pin does not exceed $C_L = 20 \text{ pF}$ with the maximum driver and sharp edge.

Note: The maximum peak-to-peak noise on the power supply voltage, is limited to a peak-to-peak voltage of $V_{\text{PP}} = 100 \text{ mV}$ for noise frequencies below 300 KHz and $V_{\text{PP}} = 40 \text{ mV}$ for noise frequencies above 300 KHz. These conditions can be achieved by appropriate blocking of the supply voltage as near as possible to the supply pins and using PCB supply and ground planes.

3.18 ERAY Phase Locked Loop (ERAY_PLL)

Table 3-42 PLL_ERAY

Parameter	Symbol	Values			Unit	Note / Test Condition
		Min.	Typ.	Max.		
PLL Base Frequency of the ERAY PLL	$f_{\text{PLLBASE_ERAY CC}}$	50	200	320	MHz	
VCO frequency range of the ERAY PLL	$f_{\text{VCO_ERAY SR}}$	400	-	480	MHz	
VCO input frequency of the ERAY PLL	$f_{\text{REF SR}}$	16	-	24	MHz	
Accumulated_Jitter	$D_{\text{p CC}}$	-0.5	-	0.5	ns	
Accumulated jitter at SYSCLK pin	$D_{\text{pp CC}}$	-0.8	-	0.8	ns	
PLL lock-in time	$t_{\text{L CC}}$	5.6	-	200	μs	

Note: The specified PLL jitter values are valid if the capacitive load per pin does not exceed $C_L = 20 \text{ pF}$ with the maximum driver and sharp edge.

Note: The maximum peak-to-peak noise on the power supply voltage, is limited to a peak-to-peak voltage of $V_{\text{pp}} = 100 \text{ mV}$ for noise frequencies below 300 KHz and $V_{\text{pp}} = 40 \text{ mV}$ for noise frequencies above 300 KHz. These conditions can be achieved by appropriate blocking of the supply voltage as near as possible to the supply pins and using PCB supply and ground planes.

3.19 AC Specifications

All AC parameters are specified for the complete operating range defined in [Chapter 3.4](#) unless otherwise noted in column Note / test Condition.

Unless otherwise noted in the figures the timings are defined with the following guidelines:

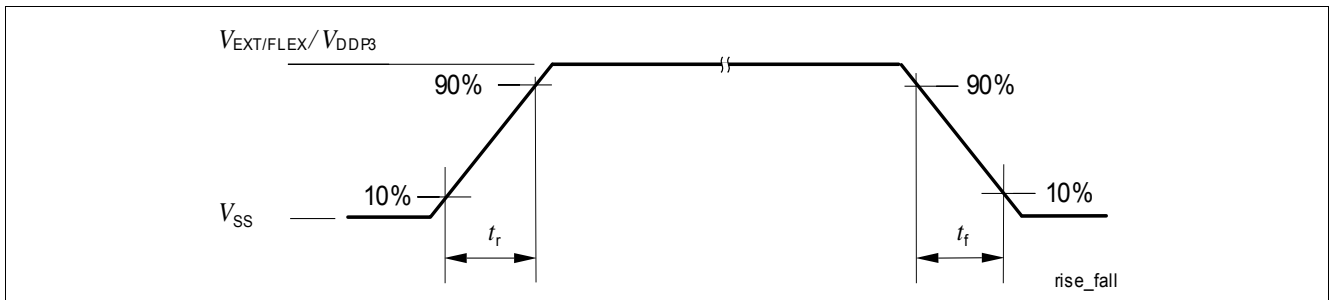

Figure 3-9 Definition of rise / fall times

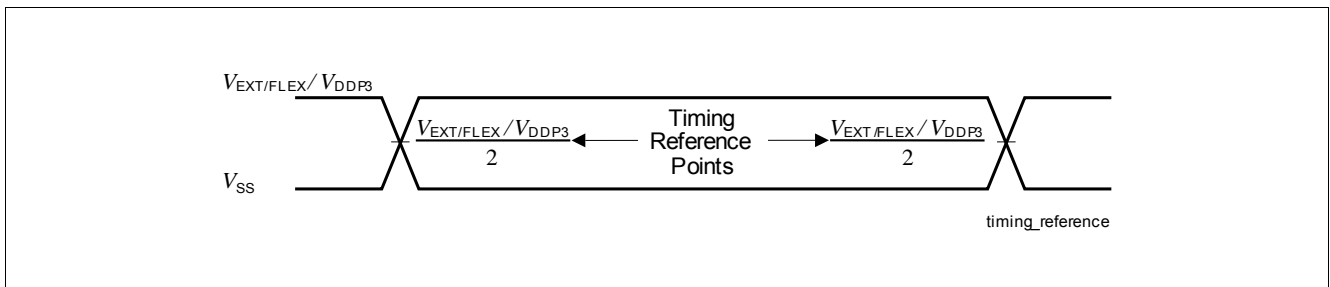

Figure 3-10 Time Reference Point Definition

3.20 JTAG Parameters

The following parameters are applicable for communication through the JTAG debug interface. The JTAG module is fully compliant with IEEE1149.1-2000.

Table 3-43 JTAG

Parameter	Symbol	Values			Unit	Note / Test Condition
		Min.	Typ.	Max.		
TCK clock period	t_1 SR	25	-	-	ns	
TCK high time	t_2 SR	10	-	-	ns	
TCK low time	t_3 SR	10	-	-	ns	
TCK clock rise time	t_4 SR	-	-	4	ns	
TCK clock fall time	t_5 SR	-	-	4	ns	
TDI/TMS setup to TCK rising edge	t_6 SR	6.0	-	-	ns	
TDI/TMS hold after TCK rising edge	t_7 SR	6.0	-	-	ns	
TDO valid after TCK falling edge (propagation delay) ¹⁾	t_8 CC	3.0	-	-	ns	$C_L \leq 20\text{pF}$
		-	-	16.5	ns	$C_L \leq 50\text{pF}$
TDO hold after TCK falling edge ¹⁾	t_{18} CC	2	-	-	ns	
TDO high impedance to valid from TCK falling edge ¹⁾²⁾	t_9 CC	-	-	17.5	ns	$C_L \leq 50\text{pF}$
TDO valid output to high impedance from TCK falling edge ¹⁾	t_{10} CC	-	-	17.5	ns	$C_L \leq 50\text{pF}$

1) The falling edge on TCK is used to generate the TDO timing.

2) The setup time for TDO is given implicitly by the TCK cycle time.

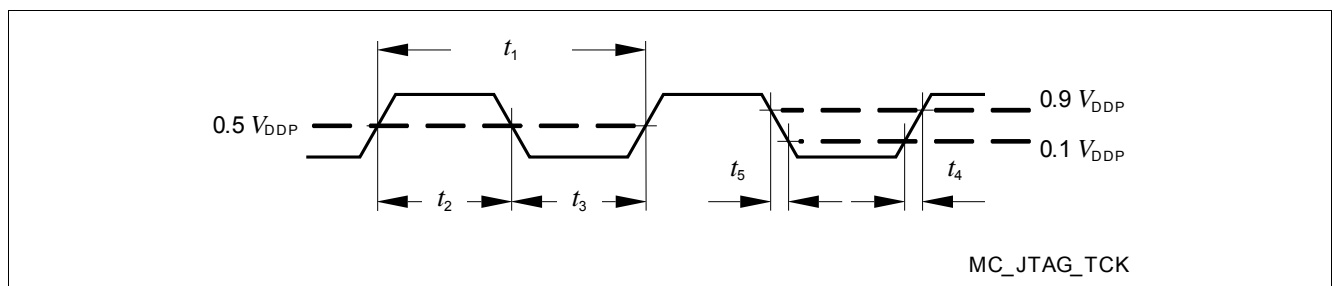

Figure 3-11 Test Clock Timing (TCK)

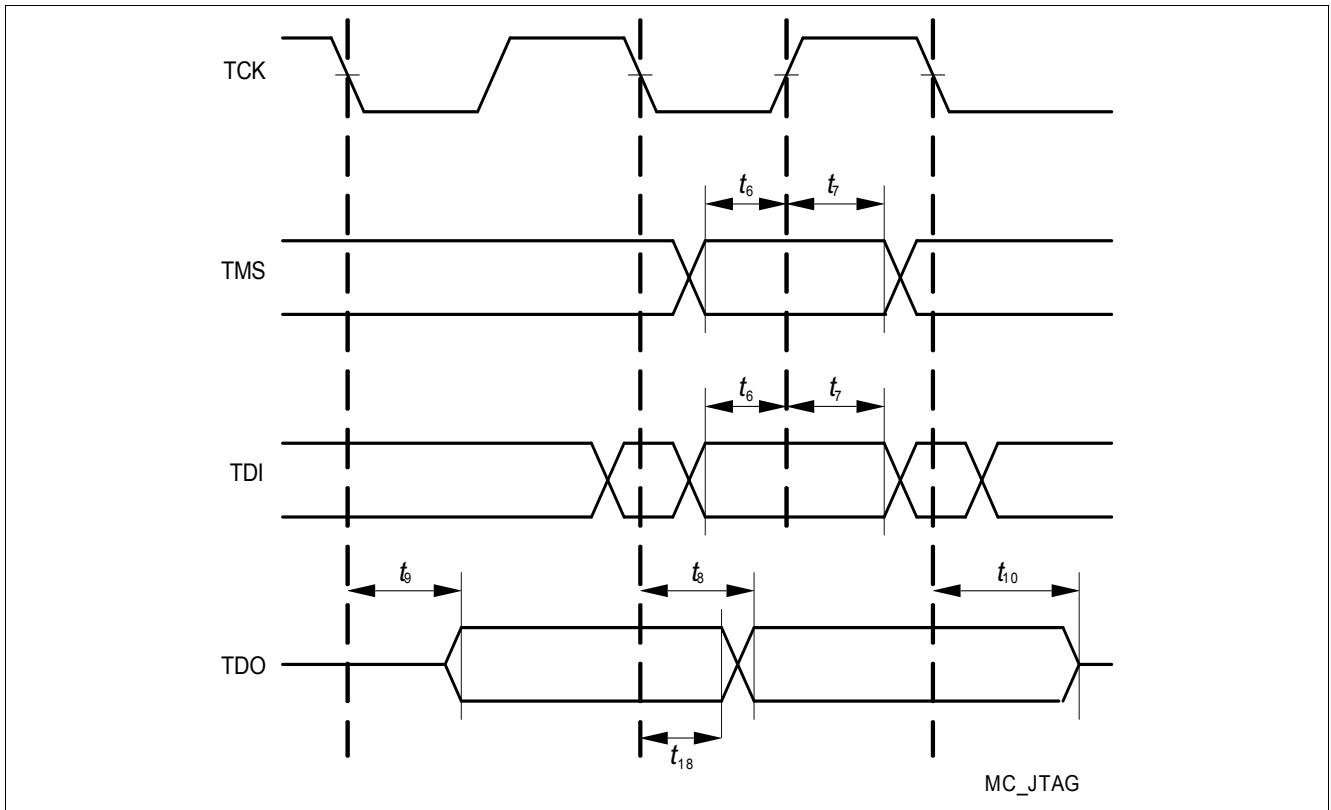

Figure 3-12 JTAG Timing

3.21 DAP Parameters

The following parameters are applicable for communication through the DAP debug interface.

Table 3-44 DAP

Parameter	Symbol	Values			Unit	Note / Test Condition
		Min.	Typ.	Max.		
DAP0 clock period	t_{11} SR	6.25	-	-	ns	
DAP0 high time	t_{12} SR	2	-	-	ns	
DAP0 low time	t_{13} SR	2	-	-	ns	
DAP0 clock rise time	t_{14} SR	-	-	1	ns	$f=160\text{MHz}$
		-	-	2	ns	$f=80\text{MHz}$
DAP0 clock fall time	t_{15} SR	-	-	1	ns	$f=160\text{MHz}$
		-	-	2	ns	$f=80\text{MHz}$
DAP1 setup to DAP0 rising edge	t_{16} SR	4	-	-	ns	
DAP1 hold after DAP0 rising edge	t_{17} SR	2	-	-	ns	
DAP1 valid per DAP0 clock period ¹⁾	t_{19} CC	3	-	-	ns	$C_L=20\text{pF}; f=160\text{MHz}$
		8	-	-	ns	$C_L=20\text{pF}; f=80\text{MHz}$
		10	-	-	ns	$C_L=50\text{pF}; f=40\text{MHz}$

1) The Host has to find a suitable sampling point by analyzing the sync telegram response.

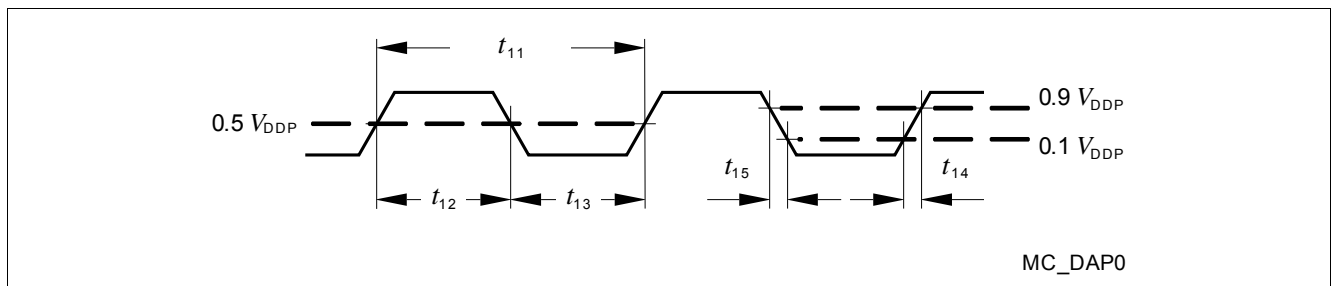

Figure 3-13 Test Clock Timing (DAP0)

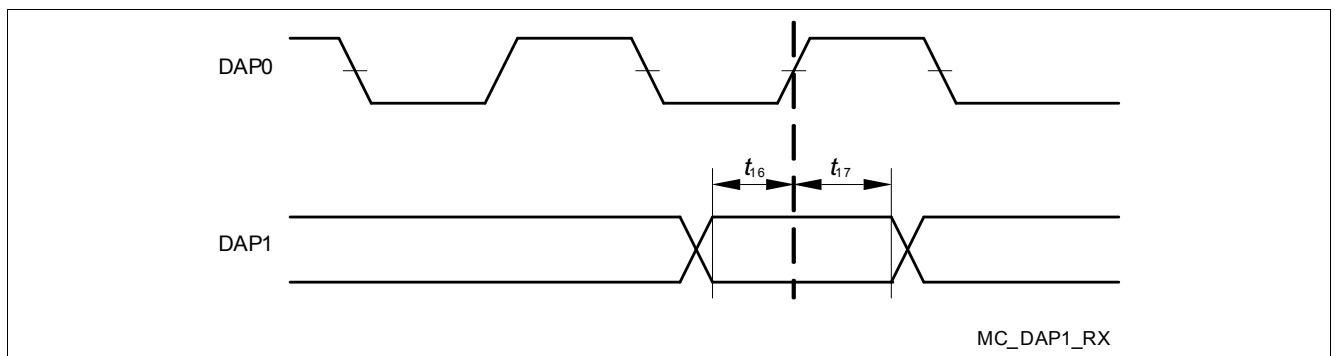

Figure 3-14 DAP Timing Host to Device

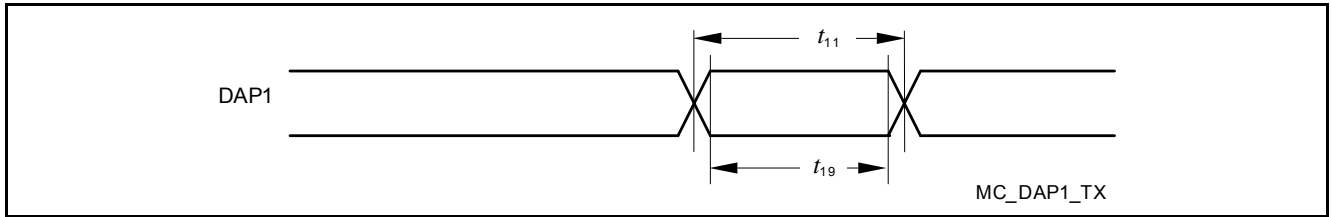

Figure 3-15 DAP Timing Device to Host (DAP1 and DAP2 pins)

Note: The DAP1 and DAP2 device to host timing is individual for both pins. There is no guaranteed max. signal skew.

3.22 ASCLIN SPI Master Timing

This section defines the timings for the ASCLIN in the TC290 / TC297 / TC298 / TC299, for 5V power supply.

Note: Pad asymmetry is already included in the following timings.

Table 3-45 Master Mode MP+ss/MPRss output pads

Parameter	Symbol	Values			Unit	Note / Test Condition
		Min.	Typ.	Max.		
ASCLKO clock period ¹⁾	t_{50} CC	20	-	-	ns	$C_L=25\text{pF}$
Deviation from ideal duty cycle ²⁾	t_{500} CC	-3	-	3	ns	$0 < C_L < 50\text{pF}$
MTRSR delay from ASCLKO shifting edge	t_{51} CC	-7	-	6	ns	$C_L=25\text{pF}$
ASLSON delay from the first ASCLKO edge	t_{510} CC	5	-	35	ns	$C_L=25\text{pF}$; pad used = LPm
MRST setup to ASCLKO latching edge	t_{52} SR	30	-	-	ns	$C_L=25\text{pF}$
MRST hold from ASCLKO latching edge	t_{53} SR	-4.5	-	-	ns	$C_L=25\text{pF}$

- 1) PLL Jitter not included. Should be considered additionally, corresponding to the used baudrate. The duty cycle can be adjusted using the BITCON.SAMPLEPOINT bitfield with the finest granularity of $T_{MAX} = 1 / f_{MAX}$.
- 2) Positive deviation lengthens the high time and shortens the low time of a clock period. Negative deviation does the opposite.

Table 3-46 Master Mode MP+sm/MPRsm output pads

Parameter	Symbol	Values			Unit	Note / Test Condition
		Min.	Typ.	Max.		
ASCLKO clock period ¹⁾	t_{50} CC	50	-	-	ns	$C_L=50\text{pF}$
Deviation from ideal duty cycle ²⁾	t_{500} CC	-2	-	$3+0.01 \cdot C_L$ *	ns	$0 < C_L < 200\text{pF}$
MTRSR delay from ASCLKO shifting edge	t_{51} CC	-10	-	10	ns	$C_L=50\text{pF}$
ASLSON delay from the first ASCLKO edge	t_{510} CC	5	-	35	ns	$C_L=50\text{pF}$; pad used = LPm
MRST setup to ASCLKO latching edge	t_{52} SR	50	-	-	ns	$C_L=50\text{pF}$
MRST hold from ASCLKO latching edge	t_{53} SR	-9	-	-	ns	$C_L=50\text{pF}$

- 1) PLL Jitter not included. Should be considered additionally, corresponding to the used baudrate. The duty cycle can be adjusted using the BITCON.SAMPLEPOINT bitfield with the finest granularity of $T_{MAX} = 1 / f_{MAX}$.
- 2) Positive deviation lengthens the high time and shortens the low time of a clock period. Negative deviation does the opposite.

Electrical Specification ASCLIN SPI Master Timing

Table 3-47 Master Mode MPss output pads

Parameter	Symbol	Values			Unit	Note / Test Condition
		Min.	Typ.	Max.		
ASCLKO clock period ¹⁾	t_{50} CC	20	-	-	ns	$C_L=25\text{pF}$
Deviation from ideal duty cycle ²⁾	t_{500} CC	-2	-	$3.5+0.035 * C_L$	ns	$0 < C_L < 200\text{pF}$
MTSR delay from ASCLKO shifting edge	t_{51} CC	-7	-	6	ns	$C_L=25\text{pF}$
ASLSON delay from the first ASCLKO edge	t_{510} CC	-7	-	6	ns	$C_L=25\text{pF}$
MRST setup to ASCLKO latching edge	t_{52} SR	31	-	-	ns	$C_L=25\text{pF}$, else
		33 ³⁾	-	-	ns	$C_L=25\text{pF}$, for P14.2, P14.4, and P15.1
MRST hold from ASCLKO latching edge	t_{53} SR	-5	-	-	ns	$C_L=25\text{pF}$

- 1) PLL Jitter not included. Should be considered additionally, corresponding to the used baudrate. The duty cycle can be adjusted using the BITCON.SAMPLEPOINT bitfield with the finest granularity of $T_{MAX} = 1 / f_{MAX}$.
- 2) Positive deviation lengthens the high time and shortens the low time of a clock period. Negative deviation does the opposite.
- 3) Please note that these pins didn't support the hystereses inactive feature.

Table 3-48 Master Mode MPsm output pads

Parameter	Symbol	Values			Unit	Note / Test Condition
		Min.	Typ.	Max.		
ASCLKO clock period ¹⁾	t_{50} CC	100	-	-	ns	$C_L=50\text{pF}$
Deviation from ideal duty cycle ²⁾	t_{500} CC	-3	-	$4+0.04 * C_L$	ns	$0 < C_L < 200\text{pF}$
MTSR delay from ASCLKO shifting edge	t_{51} CC	-11	-	10	ns	$C_L=50\text{pF}$
ASLSON delay from the first ASCLKO edge	t_{510} CC	-11	-	10	ns	$C_L=50\text{pF}$
MRST setup to ASCLKO latching edge	t_{52} SR	60	-	-	ns	$C_L=50\text{pF}$
MRST hold from ASCLKO latching edge	t_{53} SR	-10	-	-	ns	$C_L=50\text{pF}$

- 1) PLL Jitter not included. Should be considered additionally, corresponding to the used baudrate. The duty cycle can be adjusted using the BITCON.SAMPLEPOINT bitfield with the finest granularity of $T_{MAX} = 1 / f_{MAX}$.
- 2) Positive deviation lengthens the high time and shortens the low time of a clock period. Negative deviation does the opposite.

Electrical Specification ASCLIN SPI Master Timing

Table 3-49 Master Mode medium output pads

Parameter	Symbol	Values			Unit	Note / Test Condition
		Min.	Typ.	Max.		
ASCLKO clock period ¹⁾	t_{50} CC	200	-	-	ns	$C_L=50\text{pF}$
Deviation from ideal duty cycle ²⁾	t_{500} CC	-8	-	$4+0.06 * C_L$	ns	$0 < C_L < 200\text{pF}$
MTSR delay from ASCLKO shifting edge	t_{51} CC	-20	-	18.5	ns	$C_L=50\text{pF}$
ASLSON delay from the first ASCLKO edge	t_{510} CC	-20	-	20	ns	$C_L=50\text{pF}$
MRST setup to ASCLKO latching edge	t_{52} SR	70	-	-	ns	$C_L=50\text{pF}$
MRST hold from ASCLKO latching edge	t_{53} SR	-10	-	-	ns	$C_L=50\text{pF}$

- 1) PLL Jitter not included. Should be considered additionally, corresponding to the used baudrate. The duty cycle can be adjusted using the BITCON.SAMPLEPOINT bitfield with the finest granularity of $T_{MAX} = 1 / f_{MAX}$.
- 2) Positive deviation lengthens the high time and shortens the low time of a clock period. Negative deviation does the opposite.

Table 3-50 Master Mode weak output pads

Parameter	Symbol	Values			Unit	Note / Test Condition
		Min.	Typ.	Max.		
ASCLKO clock period ¹⁾	t_{50} CC	1000	-	-	ns	$C_L=50\text{pF}$
Deviation from ideal duty cycle ²⁾	t_{500} CC	-30	-	$30+0.15 * C_L$	ns	$0 < C_L < 200\text{pF}$
MTSR delay from ASCLKO shifting edge	t_{51} CC	-75	-	75	ns	$C_L=50\text{pF}$
ASLSON delay from the first ASCLKO edge	t_{510} CC	-65	-	65	ns	$C_L=50\text{pF}$
MRST setup to ASCLKO latching edge	t_{52} SR	510	-	-	ns	$C_L=50\text{pF}$
MRST hold from ASCLKO latching edge	t_{53} SR	-50	-	-	ns	$C_L=50\text{pF}$

- 1) PLL Jitter not included. Should be considered additionally, corresponding to the used baudrate. The duty cycle can be adjusted using the BITCON.SAMPLEPOINT bitfield with the finest granularity of $T_{MAX} = 1 / f_{MAX}$.
- 2) Positive deviation lengthens the high time and shortens the low time of a clock period. Negative deviation does the opposite.

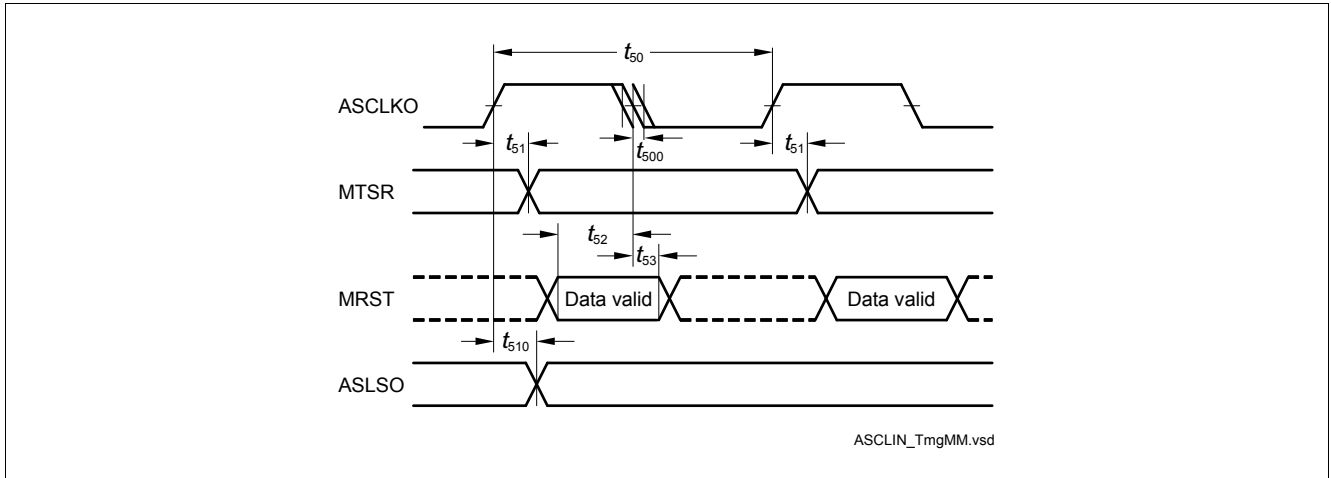

Figure 3-16 ASCLIN SPI Master Timing

3.23 ASCLIN SPI Master Timing

This section defines the timings for the ASCLIN in the TC290 / TC297 / TC298 / TC299, for 3.3V power supply, Medium Performance pads, strong sharp edge (MPss), $C_L=25\text{pF}$.

Note: Pad asymmetry is already included in the following timings.

Table 3-51 Master Mode MP+ss/MPRss output pads

Parameter	Symbol	Values			Unit	Note / Test Condition
		Min.	Typ.	Max.		
ASCLKO clock period ¹⁾	t_{50} CC	40	-	-	ns	$C_L=25\text{pF}$
Deviation from ideal duty cycle ²⁾	t_{500} CC	-5	-	5	ns	$0 < C_L < 50\text{pF}$
MTR delay from ASCLKO shifting edge	t_{51} CC	-12	-	12	ns	$C_L=25\text{pF}$
ASLSON delay from the first ASCLKO edge	t_{510} CC	0	-	60	ns	$C_L=25\text{pF}$; pad used = LPM
MRST setup to ASCLKO latching edge	t_{52} SR	50	-	-	ns	$C_L=25\text{pF}$
MRST hold from ASCLKO latching edge	t_{53} SR	-5	-	-	ns	$C_L=25\text{pF}$

1) PLL Jitter not included. Should be considered additionally, corresponding to the used baudrate. The duty cycle can be adjusted using the BITCON.SAMPLEPOINT bitfield with the finest granularity of $T_{MAX} = 1 / f_{MAX}$.

2) Positive deviation lengthens the high time and shortens the low time of a clock period. Negative deviation does the opposite.

Table 3-52 Master Mode MP+sm/MPRsm output pads

Parameter	Symbol	Values			Unit	Note / Test Condition
		Min.	Typ.	Max.		
ASCLKO clock period ¹⁾	t_{50} CC	100	-	-	ns	$C_L=50\text{pF}$
Deviation from ideal duty cycle ²⁾	t_{500} CC	-3	-	7	ns	$0 < C_L < 200\text{pF}$
MTR delay from ASCLKO shifting edge	t_{51} CC	-17	-	17	ns	$C_L=50\text{pF}$
ASLSON delay from the first ASCLKO edge	t_{510} CC	0	-	60	ns	$C_L=50\text{pF}$; pad used = LPM
MRST setup to ASCLKO latching edge	t_{52} SR	85	-	-	ns	$C_L=50\text{pF}$
MRST hold from ASCLKO latching edge	t_{53} SR	-5	-	-	ns	$C_L=50\text{pF}$

1) PLL Jitter not included. Should be considered additionally, corresponding to the used baudrate. The duty cycle can be adjusted using the BITCON.SAMPLEPOINT bitfield with the finest granularity of $T_{MAX} = 1 / f_{MAX}$.

2) Positive deviation lengthens the high time and shortens the low time of a clock period. Negative deviation does the opposite.

Electrical Specification ASCLIN SPI Master Timing

Table 3-53 Master Mode MPss output pads

Parameter	Symbol	Values			Unit	Note / Test Condition
		Min.	Typ.	Max.		
ASCLKO clock period ¹⁾	t_{50} CC	40	-	-	ns	$C_L=25\text{pF}$
Deviation from ideal duty cycle ²⁾	t_{500} CC	-5	-	$7+0.07 \cdot C_L$	ns	$0 < C_L < 200\text{pF}$
MTSR delay from ASCLKO shifting edge	t_{51} CC	-12	-	12	ns	$C_L=25\text{pF}$
ASLSON delay from the first ASCLKO edge	t_{510} CC	-12	-	12	ns	$C_L=25\text{pF}$
MRST setup to ASCLKO latching edge	t_{52} SR	50	-	-	ns	$C_L=25\text{pF}$
MRST hold from ASCLKO latching edge	t_{53} SR	-5	-	-	ns	$C_L=25\text{pF}$

- 1) PLL Jitter not included. Should be considered additionally, corresponding to the used baudrate. The duty cycle can be adjusted using the BITCON.SAMPLEPOINT bitfield with the finest granularity of $T_{MAX} = 1 / f_{MAX}$.
- 2) Positive deviation lengthens the high time and shortens the low time of a clock period. Negative deviation does the opposite.

Table 3-54 Master Mode MPsm output pads

Parameter	Symbol	Values			Unit	Note / Test Condition
		Min.	Typ.	Max.		
ASCLKO clock period ¹⁾	t_{50} CC	200	-	-	ns	$C_L=50\text{pF}$
Deviation from ideal duty cycle ²⁾	t_{500} CC	-5	-	$9+0.06 \cdot C_L$	ns	$0 < C_L < 200\text{pF}$
MTSR delay from ASCLKO shifting edge	t_{51} CC	-19	-	17	ns	$C_L=50\text{pF}$
ASLSON delay from the first ASCLKO edge	t_{510} CC	-19	-	17	ns	$C_L=50\text{pF}$
MRST setup to ASCLKO latching edge	t_{52} SR	100	-	-	ns	$C_L=50\text{pF}$
MRST hold from ASCLKO latching edge	t_{53} SR	-13	-	-	ns	$C_L=50\text{pF}$

- 1) PLL Jitter not included. Should be considered additionally, corresponding to the used baudrate. The duty cycle can be adjusted using the BITCON.SAMPLEPOINT bitfield with the finest granularity of $T_{MAX} = 1 / f_{MAX}$.
- 2) Positive deviation lengthens the high time and shortens the low time of a clock period. Negative deviation does the opposite.

Table 3-55 Master Mode medium output pads

Parameter	Symbol	Values			Unit	Note / Test Condition
		Min.	Typ.	Max.		
ASCLKO clock period ¹⁾	t_{50} CC	400	-	-	ns	$C_L=50\text{pF}$
Deviation from ideal duty cycle ²⁾	t_{500} CC	$-6-0.07 \cdot C_L$	-	$6+0.07 \cdot C_L$	ns	$0 < C_L < 200\text{pF}$

Electrical Specification ASCLIN SPI Master Timing

Table 3-55 Master Mode medium output pads (cont'd)

Parameter	Symbol	Values			Unit	Note / Test Condition
		Min.	Typ.	Max.		
MTSR delay from ASCLKO shifting edge	t_{51} CC	-33	-	25	ns	$C_L=50\text{pF}$
ASLSON delay from the first ASCLKO edge	t_{510} CC	-35	-	35	ns	$C_L=50\text{pF}$
MRST setup to ASCLKO latching edge	t_{52} SR	120	-	-	ns	$C_L=50\text{pF}$
MRST hold from ASCLKO latching edge	t_{53} SR	-13	-	-	ns	$C_L=50\text{pF}$

- 1) PLL Jitter not included. Should be considered additionally, corresponding to the used baudrate. The duty cycle can be adjusted using the BITCON.SAMPLEPOINT bitfield with the finest granularity of $T_{MAX} = 1 / f_{MAX}$.
- 2) Positive deviation lengthens the high time and shortens the low time of a clock period. Negative deviation does the opposite.

Table 3-56 Master Mode weak output pads

Parameter	Symbol	Values			Unit	Note / Test Condition
		Min.	Typ.	Max.		
ASCLKO clock period ¹⁾	t_{50} CC	2000	-	-	ns	$C_L=50\text{pF}$
Deviation from ideal duty cycle ²⁾	t_{500} CC	-110	-	150	ns	$0 < C_L < 200\text{pF}$
MTSR delay from ASCLKO shifting edge	t_{51} CC	-170	-	170	ns	$C_L=50\text{pF}$
ASLSON delay from the first ASCLKO edge	t_{510} CC	-170	-	170	ns	$C_L=50\text{pF}$
MRST setup to ASCLKO latching edge	t_{52} SR	510	-	-	ns	$C_L=50\text{pF}$
MRST hold from ASCLKO latching edge	t_{53} SR	-40	-	-	ns	$C_L=50\text{pF}$

- 1) PLL Jitter not included. Should be considered additionally, corresponding to the used baudrate. The duty cycle can be adjusted using the BITCON.SAMPLEPOINT bitfield with the finest granularity of $T_{MAX} = 1 / f_{MAX}$.
- 2) Positive deviation lengthens the high time and shortens the low time of a clock period. Negative deviation does the opposite.

Table 3-57 Master Mode A2ss output pads

Parameter	Symbol	Values			Unit	Note / Test Condition
		Min.	Typ.	Max.		
ASCLKO clock period ¹⁾	t_{50} CC	20	-	-	ns	$C_L=50\text{pF}$
Deviation from ideal duty cycle ²⁾	t_{500} CC	-3	-	3	ns	$C_L=50\text{pF}$
MTSR delay from ASCLKO shifting edge	t_{51} CC	-4	-	4	ns	$C_L=50\text{pF}$
ASLSON delay from the first ASCLKO edge	t_{510} CC	-5	-	4	ns	$C_L=50\text{pF}$

Table 3-57 Master Mode A2ss output pads (cont'd)

Parameter	Symbol	Values			Unit	Note / Test Condition
		Min.	Typ.	Max.		
MRST setup to ASCLKO latching edge	t_{52} SR	17	-	-	ns	$C_L=50\text{pF}$
MRST hold from ASCLKO latching edge	t_{53} SR	0	-	-	ns	$C_L=50\text{pF}$

- 1) PLL Jitter not included. Should be considered additionally, corresponding to the used baudrate. The duty cycle can be adjusted using the BITCON.SAMPLEPOINT bitfield with the finest granularity of $T_{MAX} = 1 / f_{MAX}$.
- 2) Positive deviation lengthens the high time and shortens the low time of a clock period. Negative deviation does the opposite.

Table 3-58 Master Mode A2sm output pads

Parameter	Symbol	Values			Unit	Note / Test Condition
		Min.	Typ.	Max.		
ASCLKO clock period ¹⁾	t_{50} CC	40	-	-	ns	$C_L=50\text{pF}$
Deviation from ideal duty cycle ²⁾	t_{500} CC	-4	-	4	ns	$C_L=50\text{pF}$
MSTR delay from ASCLKO shifting edge	t_{51} CC	-8	-	6	ns	$C_L=50\text{pF}$
ASLSON delay from the first ASCLKO edge	t_{510} CC	-8	-	9	ns	$C_L=50\text{pF}$
MRST setup to ASCLKO latching edge	t_{52} SR	26	-	-	ns	$C_L=50\text{pF}$
MRST hold from ASCLKO latching edge	t_{53} SR	0	-	-	ns	$C_L=50\text{pF}$

- 1) PLL Jitter not included. Should be considered additionally, corresponding to the used baudrate. The duty cycle can be adjusted using the BITCON.SAMPLEPOINT bitfield with the finest granularity of $T_{MAX} = 1 / f_{MAX}$.
- 2) Positive deviation lengthens the high time and shortens the low time of a clock period. Negative deviation does the opposite.

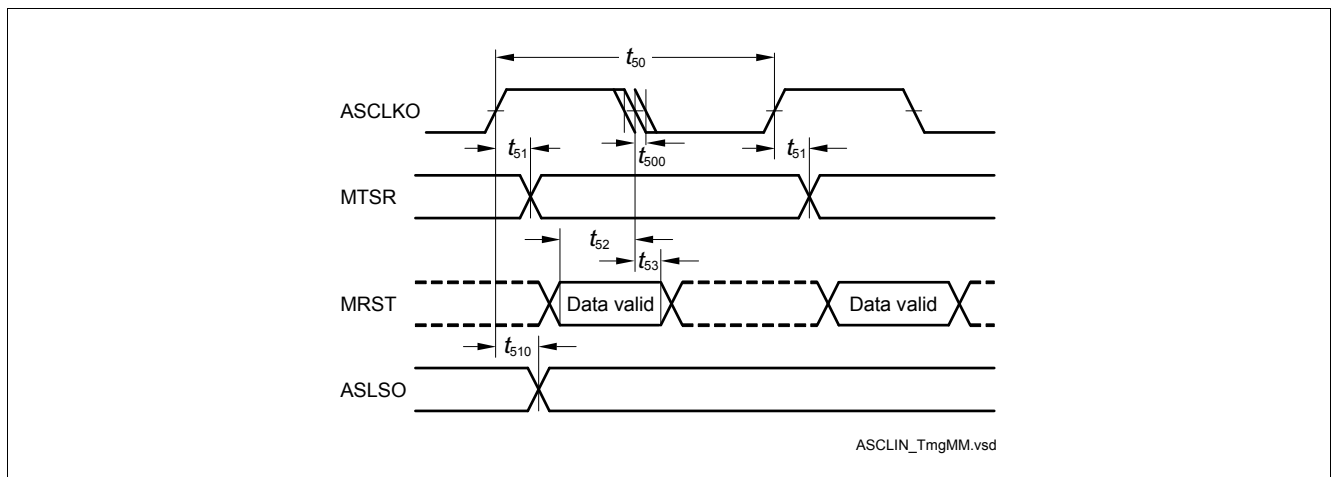

Figure 3-17 ASCLIN SPI Master Timing

3.24 QSPI Timings, Master and Slave Mode

This section defines the timings for the QSPI in the TC290 / TC297 / TC298 / TC299, for 5V pad power supply. It is assumed that SCLKO, MTSR, and SLSO pads have the same pad settings:

- LVDSM output pads, LVDSH input pad, master mode, $C_L=25\text{pF}$
- Medium Performance Plus Pads (MP+):
 - strong sharp edge (MP+ss), $C_L=25\text{pF}$
 - strong medium edge (MP+sm), $C_L=50\text{pF}$
 - medium edge (MP+m), $C_L=50\text{pF}$
 - weak edge (MP+w), $C_L=50\text{pF}$
- Medium Performance Pads (MP):
 - strong sharp edge (MPss), $C_L=25\text{pF}$
 - strong medium edge (MPsm), $C_L=50\text{pF}$
- Medium and Low Performance Pads (MP/LP), the identical output strength settings:
 - medium edge (LP/MPm), $C_L=50\text{pF}$
 - weak edge (MPw), $C_L=50\text{pF}$

Table 3-59 Master Mode Timing, LVDSM output pads for data and clock

Parameter	Symbol	Values			Unit	Note / Test Condition
		Min.	Typ.	Max.		
SCLKO clock period ¹⁾	t_{50} CC	20 ²⁾	-	-	ns	$C_L=25\text{pF}$
Deviation from the ideal duty cycle ^{3) 4)}	t_{500} CC	-1	-	1	ns	$C_L=25\text{pF}$
MTSR delay from SCLKO shifting edge	t_{51} CC	-3	-	3	ns	$C_L=25\text{pF}$
SLSO deviation from the ideal programmed position	t_{510} CC	0	-	30	ns	$C_L=25\text{pF}$; MPsm
		-5	-	7	ns	$C_L=25\text{pF}$; MPss
		-4	-	7	ns	MP+ss; $C_L=25\text{pF}$
		-1	-	15	ns	MP+sm; $C_L=25\text{pF}$
MRST setup to SCLK latching edge ⁵⁾	t_{52} SR	19 ⁵⁾	-	-	ns	$C_L=25\text{pF}$; LVDSM 5V output and LVDSH 3.3V input
MRST hold from SCLK latching edge	t_{53} SR	-6 ⁵⁾	-	-	ns	$C_L=25\text{pF}$; LVDSM 5V output and LVDSH 3.3V input

- 1) Documented value is valid for master transmit or slave receive only. For full duplex the external SPI counterpart timing has to be taken into account.
- 2) The capacitive load on the LVDS pins is differential, the capacitive load on the CMOS pins is single ended.
- 3) The PLL jitter is not included. It should be considered additionally, corresponding to the used baudrate. The duty cycle can be adjusted using the bit fields ECONZ.A, B and C with the finest granularity of $T_{MAX} = 1 / f_{MAX}$.
- 4) Positive deviation lengthens the high time and shortens the low time of a clock period. Negative deviation does the opposite.
- 5) For compensation of the average on-chip delay the QSPI module provides the bit fields ECONZ.A, B and C.

Electrical Specification QSPI Timings, Master and Slave Mode

Table 3-60 Master Mode MP+ss/MPRss output pads

Parameter	Symbol	Values			Unit	Note / Test Condition
		Min.	Typ.	Max.		
SCLKO clock period ¹⁾	t_{50} CC	20	-	-	ns	$C_L=25\text{pF}$
Deviation from the ideal duty cycle ^{2) 3)}	t_{500} CC	-3	-	3	ns	$0 < C_L < 50\text{pF}$
MISR delay from SCLKO shifting edge	t_{51} CC	-7	-	6	ns	$C_L=25\text{pF}$
SLSON deviation from the ideal programmed position	t_{510} CC	-7	-	6	ns	$C_L=25\text{pF}$
MRST setup to SCLK latching edge ⁴⁾	t_{52} SR	27 ⁴⁾⁵⁾	-	-	ns	$C_L=25\text{pF}$
MRST hold from SCLK latching edge	t_{53} SR	-4.5 ⁴⁾⁵⁾	-	-	ns	$C_L=25\text{pF}$

- 1) Documented value is valid for master transmit or slave receive only. For full duplex the external SPI counterpart timing has to be taken into account.
- 2) The PLL jitter is not included. It should be considered additionally, corresponding to the used baudrate. The duty cycle can be adjusted using the bit fields ECONz.A, B and C with the finest granularity of $T_{MAX} = 1 / f_{MAX}$.
- 3) Positive deviation lengthens the high time and shortens the low time of a clock period. Negative deviation does the opposite.
- 4) For compensation of the average on-chip delay the QSPI module provides the bit fields ECONz.A, B and C.
- 5) The setup and hold times are valid for both settings of the input pads thresholds: TTL and AL.

Table 3-61 Master Mode MP+sm/MPRsm output pads for data and clock

Parameter	Symbol	Values			Unit	Note / Test Condition
		Min.	Typ.	Max.		
SCLKO clock period ¹⁾	t_{50} CC	50	-	-	ns	$C_L=50\text{pF}$
Deviation from the ideal duty cycle ^{2) 3)}	t_{500} CC	-2	-	$3+0.01 * C_L$	ns	$0 < C_L < 200\text{pF}$
MISR delay from SCLKO shifting edge	t_{51} CC	-10	-	10	ns	$C_L=50\text{pF}$
SLSON deviation from the ideal programmed position	t_{510} CC	-10	-	10	ns	MP+sm; $C_L=50\text{pF}$
		-13	-	1	ns	MPss; $C_L=50\text{pF}$
		0	-	40	ns	MP+m, MPm, LPM; $C_L=50\text{pF}$
MRST setup to SCLK latching edge ⁴⁾	t_{52} SR	50 ⁴⁾⁵⁾	-	-	ns	$C_L=50\text{pF}$
MRST hold from SCLK latching edge	t_{53} SR	-9 ⁴⁾⁵⁾	-	-	ns	$C_L=50\text{pF}$

- 1) Documented value is valid for master transmit or slave receive only. For full duplex the external SPI counterpart timing has to be taken into account.
- 2) The PLL jitter is not included. It should be considered additionally, corresponding to the used baudrate. The duty cycle can be adjusted using the bit fields ECONz.A, B and C with the finest granularity of $T_{MAX} = 1 / f_{MAX}$.
- 3) Positive deviation lengthens the high time and shortens the low time of a clock period. Negative deviation does the opposite.

Electrical Specification QSPI Timings, Master and Slave Mode

- 4) For compensation of the average on-chip delay the QSPI module provides the bit fields ECONz.A, B and C.
- 5) The setup and hold times are valid for both settings of the input pads thresholds: TTL and AL.

Table 3-62 Master Mode timing MPss output pads for data and clock, CL=50pF

Parameter	Symbol	Values			Unit	Note / Test Condition
		Min.	Typ.	Max.		
SCLKO clock period ¹⁾	t_{50} CC	40	-	-	ns	$C_L=50\text{pF}$
Deviation from the ideal duty cycle ^{2) 3)}	t_{500} CC	-2	-	$3.5+0.035 * C_L$	ns	$0 < C_L < 200\text{pF}$
MISR delay from SCLKO shifting edge	t_{51} CC	-8	-	8	ns	$C_L=50\text{pF}$
SLSON deviation from the ideal programmed position	t_{510} CC	-8	-	8	ns	MPss; $C_L=50\text{pF}$
		-1	-	15	ns	MP+sm; $C_L=50\text{pF}$
		0	-	50	ns	MP+m, MPm, LPM; $C_L=50\text{pF}$
MRST setup to SCLK latching edge ⁴⁾	t_{52} SR	$40^{4)5)}$	-	-	ns	$C_L=50\text{pF}$
MRST hold from SCLK latching edge	t_{53} SR	$-5^{4)5)}$	-	-	ns	$C_L=50\text{pF}$

- 1) Documented value is valid for master transmit or slave receive only. For full duplex the external SPI counterpart timing has to be taken into account.
- 2) The PLL jitter is not included. It should be considered additionally, corresponding to the used baudrate. The duty cycle can be adjusted using the bit fields ECONz.A, B and C with the finest granularity of $T_{MAX} = 1 / f_{MAX}$.
- 3) Positive deviation lengthens the high time and shortens the low time of a clock period. Negative deviation does the opposite.
- 4) For compensation of the average on-chip delay the QSPI module provides the bit fields ECONz.A, B and C.
- 5) The setup and hold times are valid for both settings of the input pads thresholds: TTL and AL.

Table 3-63 Master Mode timing MPsm output pads

Parameter	Symbol	Values			Unit	Note / Test Condition
		Min.	Typ.	Max.		
SCLKO clock period ¹⁾	t_{50} CC	100	-	-	ns	$C_L=50\text{pF}$
Deviation from the ideal duty cycle ^{2) 3)}	t_{500} CC	-3	-	$4+0.04 * C_L$	ns	$0 < C_L < 200\text{pF}$
MISR delay from SCLKO shifting edge	t_{51} CC	-11	-	10	ns	$C_L=50\text{pF}$
SLSON deviation from the ideal programmed position	t_{510} CC	-11	-	10	ns	$C_L=50\text{pF}$
MRST setup to SCLK latching edge ⁴⁾	t_{52} SR	$60^{4)5)}$	-	-	ns	$C_L=50\text{pF}$
MRST hold from SCLK latching edge	t_{53} SR	$-10^{4)5)}$	-	-	ns	$C_L=50\text{pF}$

- 1) Documented value is valid for master transmit or slave receive only. For full duplex the external SPI counterpart timing has to be taken into account.

Electrical Specification QSPI Timings, Master and Slave Mode

- 2) The PLL jitter is not included. It should be considered additionally, corresponding to the used baudrate. The duty cycle can be adjusted using the bit fields ECONz.A, B and C with the finest granularity of $T_{MAX} = 1 / f_{MAX}$.
- 3) Positive deviation lengthens the high time and shortens the low time of a clock period. Negative deviation does the opposite.
- 4) For compensation of the average on-chip delay the QSPI module provides the bit fields ECONz.A, B and C.
- 5) The setup and hold times are valid for both settings of the input pads thresholds: TTL and AL.

Table 3-64 Master Mode timing MPRm/MP+m/MPm/LPm output pads

Parameter	Symbol	Values			Unit	Note / Test Condition
		Min.	Typ.	Max.		
SCLKO clock period ¹⁾	t_{50} CC	200	-	-	ns	$C_L=50\text{pF}$
Deviation from the ideal duty cycle ^{2) 3)}	t_{500} CC	-10	-	$16+0.04 * C_L$	ns	$0 < C_L < 200\text{pF}$
MTSR delay from SCLKO shifting edge	t_{51} CC	-15	-	20	ns	$C_L=50\text{pF}$
SLSO on deviation from the ideal programmed position	t_{510} CC	-20	-	20	ns	$C_L=50\text{pF}$
MRST setup to SCLK latching edge ⁴⁾	t_{52} SR	$70^{4)5)}$	-	-	ns	$C_L=50\text{pF}$
MRST hold from SCLK latching edge	t_{53} SR	$-10^{4)5)}$	-	-	ns	$C_L=50\text{pF}$

- 1) Documented value is valid for master transmit or slave receive only. For full duplex the external SPI counterpart timing has to be taken into account.
- 2) The PLL jitter is not included. It should be considered additionally, corresponding to the used baudrate. The duty cycle can be adjusted using the bit fields ECONz.A, B and C with the finest granularity of $T_{MAX} = 1 / f_{MAX}$.
- 3) Positive deviation lengthens the high time and shortens the low time of a clock period. Negative deviation does the opposite.
- 4) For compensation of the average on-chip delay the QSPI module provides the bit fields ECONz.A, B and C.
- 5) The setup and hold times are valid for both settings of the input pads thresholds: TTL and AL.

Table 3-65 Master Mode Weak output pads

Parameter	Symbol	Values			Unit	Note / Test Condition
		Min.	Typ.	Max.		
SCLKO clock period ¹⁾	t_{50} CC	1000	-	-	ns	$C_L=50\text{pF}$
Deviation from the ideal duty cycle ^{2) 3)}	t_{500} CC	-30	-	$30+0.15 * C_L$	ns	$0 < C_L < 200\text{pF}$
MTSR delay from SCLKO shifting edge	t_{51} CC	-65	-	65	ns	$C_L=50\text{pF}$
SLSO on deviation from the ideal programmed position	t_{510} CC	-65	-	65	ns	$C_L=50\text{pF}$
MRST setup to SCLK latching edge ⁴⁾	t_{52} SR	$300^{4)5)}$	-	-	ns	$C_L=50\text{pF}$
MRST hold from SCLK latching edge	t_{53} SR	$-40^{4)5)}$	-	-	ns	$C_L=50\text{pF}$

- 1) Documented value is valid for master transmit or slave receive only. For full duplex the external SPI counterpart timing has to be taken into account.

Electrical Specification QSPI Timings, Master and Slave Mode

- 2) The PLL jitter is not included. It should be considered additionally, corresponding to the used baudrate. The duty cycle can be adjusted using the bit fields ECONz.A, B and C with the finest granularity of $T_{MAX} = 1 / f_{MAX}$.
- 3) Positive deviation lengthens the high time and shortens the low time of a clock period. Negative deviation does the opposite.
- 4) For compensation of the average on-chip delay the QSPI module provides the bit fields ECONz.A, B and C.
- 5) The setup and hold times are valid for both settings of the input pads thresholds: TTL and AL.

Table 3-66 Slave mode timing

Parameter	Symbol	Values			Unit	Note / Test Condition
		Min.	Typ.	Max.		
SCLK clock period	t_{54} SR	$4 \times T_{MAX}$	-	-	ns	
SCLK duty cycle	$t_{55/t54}$ SR	40	-	60	%	
MTSR setup to SCLK latching edge	t_{56} SR	4 ¹⁾	-	-	ns	Hystheresis Inactive
		5 ¹⁾	-	-	ns	Input Level AL
		5 ¹⁾	-	-	ns	Input Level TTL
MTSR hold from SCLK latching edge	t_{57} SR	3.5 ¹⁾	-	-	ns	Hystheresis Inactive
		6 ¹⁾	-	-	ns	Input Level AL
		9 ¹⁾	-	-	ns	Input Level TTL
SLSI setup to first SCLK shift edge	t_{58} SR	5 ¹⁾	-	-	ns	Hystheresis Inactive
		4 ¹⁾	-	-	ns	Input Level AL
		8 ¹⁾	-	-	ns	Input Level TTL
		6	-	-	ns	Only for pin 15.1, AL
SLSI hold from last SCLK latching edge	t_{59} SR	3 ¹⁾	-	-	ns	Hystheresis Inactive
		4 ¹⁾	-	-	ns	Input Level AL
		8 ¹⁾	-	-	ns	Input Level TTL
MRST delay from SCLK shift edge	t_{60} CC	10	-	70	ns	MP+m/MPRm; $C_L=50\text{pF}$
		9	-	50	ns	MP+sm/MPRsm; $C_L=50\text{pF}$
		5	-	30	ns	MP+ss/MPRss; $C_L=25\text{pF}$
		40	-	300	ns	MP+w/MPRw; $C_L=50\text{pF}$
		10	-	70	ns	MPm/LPm; $C_L=50\text{pF}$
		10	-	55	ns	MPsm; $C_L=50\text{pF}$
		5	-	30	ns	MPss; $C_L=25\text{pF}$
		40	-	300	ns	MPw/LPw; $C_L=50\text{pF}$
SLSI to valid data on MRST	t_{61} SR	-	-	5	ns	

1) Except pin P15.1.

Electrical Specification QSPI Timings, Master and Slave Mode

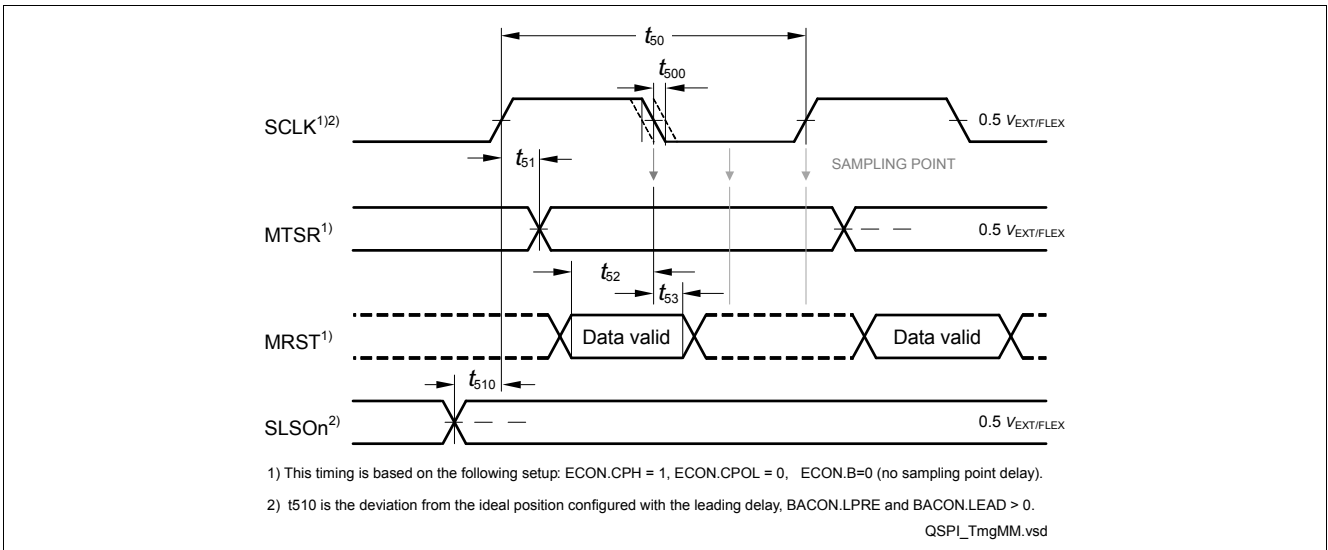

Figure 3-18 Master Mode Timing

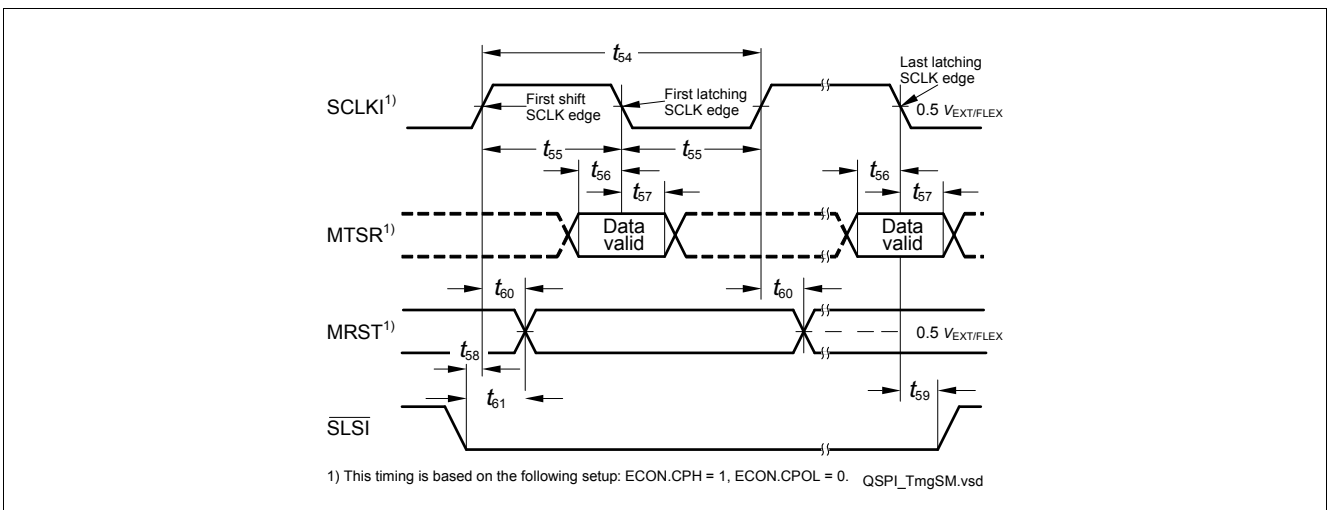

Figure 3-19 Slave Mode Timing

3.25 QSPI Timings, Master and Slave Mode

This section defines the timings for the QSPI in the TC290 / TC297 / TC298 / TC299, for 3.3V pad power supply. It is assumed that SCLKO, MTSR, and SLSO pads have the same pad settings:

- LVDSM output pads, LVDSH input pad, master mode, $C_L=25\text{pF}$
- Medium Performance Plus Pads (MP+):
 - strong sharp edge (MP+ss), $C_L=25\text{pF}$
 - strong medium edge (MP+sm), $C_L=50\text{pF}$
 - medium edge (MP+m), $C_L=50\text{pF}$
 - weak edge (MP+w), $C_L=50\text{pF}$
- Medium Performance Pads (MP):
 - strong sharp edge (MPss), $C_L=25\text{pF}$
 - strong medium edge (MPsm), $C_L=50\text{pF}$
- Medium and Low Performance Pads (MP/LP), the identical output strength settings:

Electrical Specification QSPI Timings, Master and Slave Mode

- medium edge (LP/MPm), $C_L=50\text{pF}$
- weak edge (MPw), $C_L=50\text{pF}$

Table 3-67 Master Mode Timing, LVDSM output pads for data and clock

Parameter	Symbol	Values			Unit	Note / Test Condition
		Min.	Typ.	Max.		
SCLKO clock period ¹⁾	t_{50} CC	20	-	-	ns	$C_L=25\text{pF}$
Deviation from the ideal duty cycle ^{2) 3)}	t_{500} CC	-2	-	2	ns	$C_L=25\text{pF}$
MSTR delay from SCLKO shifting edge	t_{51} CC	-5	-	5	ns	$C_L=25\text{pF}$
SLSON deviation from the ideal programmed position	t_{510} CC	-2	-	55	ns	$C_L=25\text{pF}$; MPsm
		-9	-	12	ns	$C_L=25\text{pF}$; MPss
		-7	-	12	ns	MP+ss; $C_L=25\text{pF}$
		-2	-	26	ns	MP+sm; $C_L=25\text{pF}$
MRST setup to SCLK latching edge ⁴⁾	t_{52} SR	20	-	-	ns	$C_L=25\text{pF}$; LVDSM 5V output and LVDSH 3.3V input
MRST hold from SCLK latching edge	t_{53} SR	-6	-	-	ns	$C_L=25\text{pF}$; LVDSM 5V output and LVDSH 3.3V input

- 1) Documented value is valid for master transmit or slave receive only. For full duplex the external SPI counterpart timing has to be taken into account.
- 2) The PLL jitter is not included. It should be considered additionally, corresponding to the used baudrate. The duty cycle can be adjusted using the bit fields ECONz.A, B and C with the finest granularity of $T_{MAX} = 1 / f_{MAX}$.
- 3) Positive deviation lengthens the high time and shortens the low time of a clock period. Negative deviation does the opposite.
- 4) For compensation of the average on-chip delay the QSPI module provides the bit fields ECONz.A, B and C.

Table 3-68 Master Mode MP+ss/MPRss output pads

Parameter	Symbol	Values			Unit	Note / Test Condition
		Min.	Typ.	Max.		
SCLKO clock period ¹⁾	t_{50} CC	40	-	-	ns	$C_L=25\text{pF}$
Deviation from the ideal duty cycle ^{2) 3)}	t_{500} CC	-5	-	5	ns	$0 < C_L < 50\text{pF}$
MSTR delay from SCLKO shifting edge	t_{51} CC	-12	-	12	ns	$C_L=25\text{pF}$
SLSON deviation from the ideal programmed position	t_{510} CC	-12	-	12	ns	$C_L=25\text{pF}$
MRST setup to SCLK latching edge ⁴⁾	t_{52} SR	50 ⁴⁾⁵⁾	-	-	ns	$C_L=25\text{pF}$
MRST hold from SCLK latching edge	t_{53} SR	-5 ⁴⁾⁵⁾	-	-	ns	$C_L=25\text{pF}$

- 1) Documented value is valid for master transmit or slave receive only. For full duplex the external SPI counterpart timing has to be taken into account.

Electrical Specification QSPI Timings, Master and Slave Mode

- 2) The PLL jitter is not included. It should be considered additionally, corresponding to the used baudrate. The duty cycle can be adjusted using the bit fields ECONz.A, B and C with the finest granularity of $T_{MAX} = 1 / f_{MAX}$.
- 3) Positive deviation lengthens the high time and shortens the low time of a clock period. Negative deviation does the opposite.
- 4) For compensation of the average on-chip delay the QSPI module provides the bit fields ECONz.A, B and C.
- 5) The setup and hold times are valid for both settings of the input pads thresholds: TTL and AL.

Table 3-69 Master Mode MP+sm/MPRsm output pads for data and clock

Parameter	Symbol	Values			Unit	Note / Test Condition
		Min.	Typ.	Max.		
SCLKO clock period ¹⁾	t_{50} CC	100	-	-	ns	$C_L=50\text{pF}$
Deviation from the ideal duty cycle ^{2) 3)}	t_{500} CC	-3	-	7	ns	$0 < C_L < 200\text{pF}$
MTSR delay from SCLKO shifting edge	t_{51} CC	-17	-	17	ns	$C_L=50\text{pF}$
SLSON deviation from the ideal programmed position	t_{510} CC	-17	-	17	ns	MP+sm; $C_L=50\text{pF}$
		-22	-	2	ns	MPss; $C_L=50\text{pF}$
		0	-	70	ns	MP+m; MPm; LPM; $C_L=50\text{pF}$
MRST setup to SCLK latching edge ⁴⁾	t_{52} SR	85 ⁴⁾⁵⁾	-	-	ns	$C_L=50\text{pF}$
MRST hold from SCLK latching edge	t_{53} SR	-10 ⁴⁾⁵⁾	-	-	ns	$C_L=50\text{pF}$

- 1) Documented value is valid for master transmit or slave receive only. For full duplex the external SPI counterpart timing has to be taken into account.
- 2) The PLL jitter is not included. It should be considered additionally, corresponding to the used baudrate. The duty cycle can be adjusted using the bit fields ECONz.A, B and C with the finest granularity of $T_{MAX} = 1 / f_{MAX}$.
- 3) Positive deviation lengthens the high time and shortens the low time of a clock period. Negative deviation does the opposite.
- 4) For compensation of the average on-chip delay the QSPI module provides the bit fields ECONz.A, B and C.
- 5) The setup and hold times are valid for both settings of the input pads thresholds: TTL and AL.

Table 3-70 Master Mode timing MPss output pads

Parameter	Symbol	Values			Unit	Note / Test Condition
		Min.	Typ.	Max.		
SCLKO clock period ¹⁾	t_{50} CC	40	-	-	ns	$C_L=25\text{pF}$
Deviation from the ideal duty cycle ^{2) 3)}	t_{500} CC	-5	-	$5+0.04 * C_L$	ns	$C_L=25\text{pF}$
MTSR delay from SCLKO shifting edge	t_{51} CC	-7	-	7	ns	$C_L=25\text{pF}$
SLSON deviation from the ideal programmed position	t_{510} CC	-10	-	10	ns	$C_L=25\text{pF}$

Electrical Specification QSPI Timings, Master and Slave Mode
Table 3-70 Master Mode timing MPss output pads (cont'd)

Parameter	Symbol	Values			Unit	Note / Test Condition
		Min.	Typ.	Max.		
MRST setup to SCLK latching edge ⁴⁾	t_{52} SR	50 ⁴⁾⁵⁾	-	-	ns	$C_L=25\text{pF}$
MRST hold from SCLK latching edge	t_{53} SR	-6 ⁴⁾⁵⁾	-	-	ns	$C_L=25\text{pF}$

- 1) Documented value is valid for master transmit or slave receive only. For full duplex the external SPI counterpart timing has to be taken into account.
- 2) The PLL jitter is not included. It should be considered additionally, corresponding to the used baudrate. The duty cycle can be adjusted using the bit fields ECONz.A, B and C with the finest granularity of $T_{MAX} = 1 / f_{MAX}$.
- 3) Positive deviation lengthens the high time and shortens the low time of a clock period. Negative deviation does the opposite.
- 4) For compensation of the average on-chip delay the QSPI module provides the bit fields ECONz.A, B and C.
- 5) The setup and hold times are valid for both settings of the input pads thresholds: TTL and AL.

Table 3-71 Master Mode timing MPsm output pads

Parameter	Symbol	Values			Unit	Note / Test Condition
		Min.	Typ.	Max.		
SCLKO clock period ¹⁾	t_{50} CC	200	-	-	ns	$C_L=50\text{pF}$
Deviation from the ideal duty cycle ^{2) 3)}	t_{500} CC	-5	-	$9+0.06 * C_L$	ns	$0 < C_L < 200\text{pF}$
MTSR delay from SCLKO shifting edge	t_{51} CC	-19	-	19	ns	$C_L=50\text{pF}$
SLSON deviation from the ideal programmed position	t_{510} CC	-19	-	17	ns	$C_L=50\text{pF}$
MRST setup to SCLK latching edge ⁴⁾	t_{52} SR	100 ⁴⁾⁵⁾	-	-	ns	$C_L=50\text{pF}$
MRST hold from SCLK latching edge	t_{53} SR	-13 ⁴⁾⁵⁾	-	-	ns	$C_L=50\text{pF}$

- 1) Documented value is valid for master transmit or slave receive only. For full duplex the external SPI counterpart timing has to be taken into account.
- 2) The PLL jitter is not included. It should be considered additionally, corresponding to the used baudrate. The duty cycle can be adjusted using the bit fields ECONz.A, B and C with the finest granularity of $T_{MAX} = 1 / f_{MAX}$.
- 3) Positive deviation lengthens the high time and shortens the low time of a clock period. Negative deviation does the opposite.
- 4) For compensation of the average on-chip delay the QSPI module provides the bit fields ECONz.A, B and C.
- 5) The setup and hold times are valid for both settings of the input pads thresholds: TTL and AL.

Table 3-72 Master Mode timing MPRm/MP+m/MPm/LPm output pads

Parameter	Symbol	Values			Unit	Note / Test Condition
		Min.	Typ.	Max.		
SCLKO clock period ¹⁾	t_{50} CC	400	-	-	ns	$C_L=50\text{pF}$
Deviation from the ideal duty cycle ^{2) 3)}	t_{500} CC	$-6-0.07 * C_L$	-	$6+0.095 * C_L$	ns	$0 < C_L < 200\text{pF}$

Electrical Specification QSPI Timings, Master and Slave Mode

Table 3-72 Master Mode timing MPRm/MP+m/MPm/LPm output pads (cont'd)

Parameter	Symbol	Values			Unit	Note / Test Condition
		Min.	Typ.	Max.		
MTSR delay from SCLKO shifting edge	t_{51} CC	-25	-	33	ns	$C_L=50\text{pF}$
SLSON deviation from the ideal programmed position	t_{510} CC	-35	-	35	ns	$C_L=50\text{pF}$
MRST setup to SCLK latching edge ⁴⁾	t_{52} SR	120 ⁴⁾⁵⁾	-	-	ns	$C_L=50\text{pF}$
MRST hold from SCLK latching edge	t_{53} SR	-13 ⁴⁾⁵⁾	-	-	ns	$C_L=50\text{pF}$

- 1) Documented value is valid for master transmit or slave receive only. For full duplex the external SPI counterpart timing has to be taken into account.
- 2) The PLL jitter is not included. It should be considered additionally, corresponding to the used baudrate. The duty cycle can be adjusted using the bit fields ECONz.A, B and C with the finest granularity of $T_{MAX} = 1 / f_{MAX}$.
- 3) Positive deviation lengthens the high time and shortens the low time of a clock period. Negative deviation does the opposite.
- 4) For compensation of the average on-chip delay the QSPI module provides the bit fields ECONz.A, B and C.
- 5) The setup and hold times are valid for both settings of the input pads thresholds: TTL and AL.

Table 3-73 Master Mode Weak output pads

Parameter	Symbol	Values			Unit	Note / Test Condition
		Min.	Typ.	Max.		
SCLKO clock period ¹⁾	t_{50} CC	2000	-	-	ns	$C_L=50\text{pF}$
Deviation from the ideal duty cycle ^{2) 3)}	t_{500} CC	-110	-	125	ns	$0 < C_L < 200\text{pF}$
MTSR delay from SCLKO shifting edge	t_{51} CC	-170	-	170	ns	$C_L=50\text{pF}$
SLSON deviation from the ideal programmed position	t_{510} CC	-170	-	170	ns	$C_L=50\text{pF}$
MRST setup to SCLK latching edge ⁴⁾	t_{52} SR	510 ⁴⁾⁵⁾	-	-	ns	$C_L=50\text{pF}$
MRST hold from SCLK latching edge	t_{53} SR	-40 ⁴⁾⁵⁾	-	-	ns	$C_L=50\text{pF}$

- 1) Documented value is valid for master transmit or slave receive only. For full duplex the external SPI counterpart timing has to be taken into account.
- 2) The PLL jitter is not included. It should be considered additionally, corresponding to the used baudrate. The duty cycle can be adjusted using the bit fields ECONz.A, B and C with the finest granularity of $T_{MAX} = 1 / f_{MAX}$.
- 3) Positive deviation lengthens the high time and shortens the low time of a clock period. Negative deviation does the opposite.
- 4) For compensation of the average on-chip delay the QSPI module provides the bit fields ECONz.A, B and C.
- 5) The setup and hold times are valid for both settings of the input pads thresholds: TTL and AL.

Electrical Specification QSPI Timings, Master and Slave Mode

Table 3-74 Slave mode timing

Parameter	Symbol	Values			Unit	Note / Test Condition
		Min.	Typ.	Max.		
SCLK clock period	t_{54} SR	$4 \times T_{MAX}$	-	-	ns	
SCLK duty cycle	t_{55}/t_{54} SR	40	-	60	%	
MTSR setup to SCLK latching edge	t_{56} SR	7 ¹⁾	-	-	ns	Hystheresis inactive
		9 ¹⁾	-	-	ns	Input Level AL
		7 ¹⁾	-	-	ns	Input Level TTL
MTSR hold from SCLK latching edge	t_{57} SR	5 ¹⁾	-	-	ns	Hystheresis inactive
		11 ¹⁾	-	-	ns	Input Level AL
		16 ¹⁾	-	-	ns	Input Level TTL
SLSI setup to first SCLK shift edge	t_{58} SR	7 ¹⁾	-	-	ns	Hystheresis inactive
		7 ¹⁾	-	-	ns	Input Level AL
		14 ¹⁾	-	-	ns	Input Level TTL
		11	-	-	ns	Only for pin P15.1, AL
SLSI hold from last SCLK latching edge	t_{59} SR	5 ¹⁾	-	-	ns	Hystheresis inactive
		7 ¹⁾	-	-	ns	Input Level AL
		14 ¹⁾	-	-	ns	Input Level TTL
MRST delay from SCLK shift edge	t_{60} CC	13	-	120	ns	MP+m/MPRm; $C_L=50\text{pF}$
		12.5	-	85	ns	MP+sm/MPRsm; $C_L=50\text{pF}$
		5.5	-	50	ns	MP+ss/MPRss; $C_L=25\text{pF}$
		70	-	500	ns	MP+w/MPRw; $C_L=50\text{pF}$
		13	-	120	ns	MPm/LPm; $C_L=50\text{pF}$
		13	-	100	ns	MPsm; $C_L=50\text{pF}$
		6	-	52	ns	MPss; $C_L=25\text{pF}$
		70	-	500	ns	MPw/LPw; $C_L=50\text{pF}$
SLSI to valid data on MRST	t_{61} SR	-	-	9	ns	

1) Except pin P15.1

Electrical Specification QSPI Timings, Master and Slave Mode

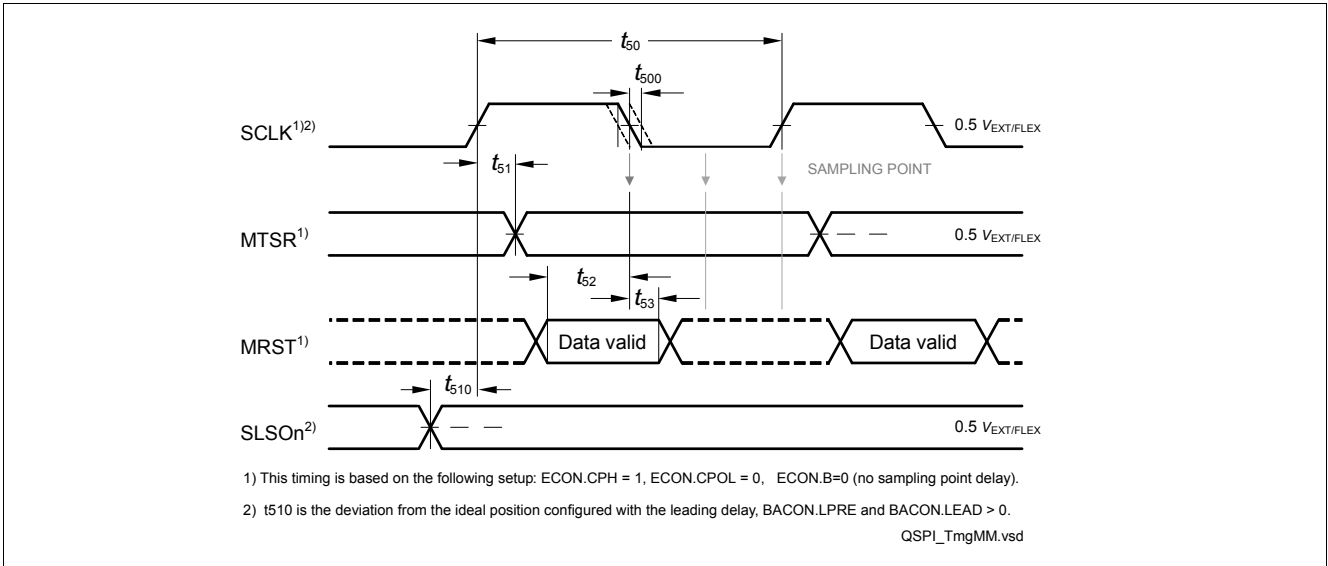

Figure 3-20 Master Mode Timing

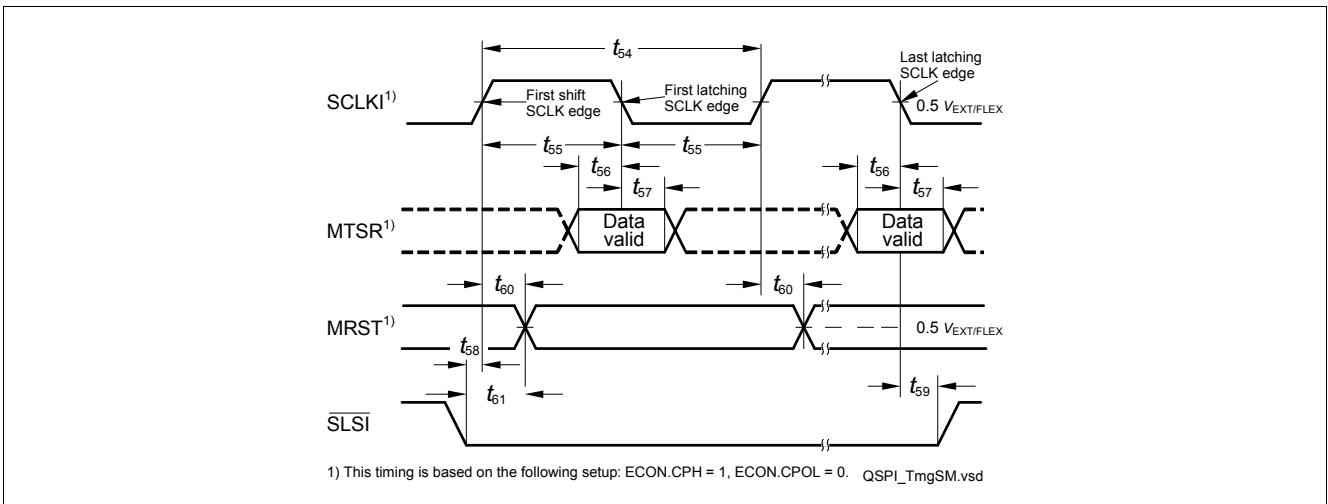

Figure 3-21 Slave Mode Timing

3.26 MSC Timing 5 V Operation

The following section defines the timings for 5V pad power supply.

Note: Pad asymmetry is already included in the following timings.

Note: Load for LVDS pads are defined as differential loads in the following timings.

Table 3-75 LVDS clock/data (LVDS pads in LVDS mode)

Parameter	Symbol	Values			Unit	Note / Test Condition
		Min.	Typ.	Max.		
FCLPx clock period ¹⁾	t_{40} CC	$2 * T_A$ ^{2) 3)}	-	-	ns	LVDSM; $C_L=50\text{pF}$
Deviation from ideal duty cycle ^{4) 5)}	t_{400} CC	-1	-	1	ns	LVDSM; $0 < C_L < 50\text{pF}$
SOPx output delay ⁶⁾	t_{44} CC	-3	-	4	ns	LVDSM; $C_L=50\text{pF}$; option EN01
		-4	-	4.5	ns	LVDSM; $C_L=50\text{pF}$; option EN01D
ENx output delay ⁶⁾	t_{45} CC	-4	-	5	ns	MP+ss/MPRss; option EN01; $C_L=25\text{pF}$
		-3.5	-	7	ns	MP+ss/MPRss; option EN01; $C_L=50\text{pF}$
		-3	-	11	ns	MP+sm/MPRsm; option EN01D; $C_L=50\text{pF}$
		-2.5	-	9	ns	MP+ss/MPRss; option EN23; $C_L=25\text{pF}$
		-2.5	-	10	ns	MP+ss/MPRss; option EN23; $C_L=50\text{pF}$
		-3	-	11	ns	MPss; option EN01; $C_L=50\text{pF}$
		-7	-	3	ns	MP+ss/MPRss; option EN01; $C_L=0\text{pF}$
		-5	-	3	ns	MP+sm/MPRsm; option EN01D; $C_L=0\text{pF}$
		-4	-	6	ns	MP+ss/MPRss; option EN23; $C_L=0\text{pF}$
		-7	-	4	ns	MPss; option EN01; $C_L=0\text{pF}$
SDI bit time	t_{46} CC	$8 * t_{\text{MSC}}$	-	-	ns	Upstream Timing
SDI rise time ⁷⁾	t_{48} SR	-	-	200	ns	Upstream Timing
SDI fall time ⁷⁾	t_{49} SR	-	-	200	ns	Upstream Timing

1) FCLP signal rise/fall times are the rise/fall times of the LVDSM pads, and the high/low times are $\min 1 * T_A$.

2) T_A depends on the clock source selected for baud rate generation in the ABRA block of the MSC.

3) The capacitive load on the LVDS pins is differential, the capacitive load on the CMOS pins is single ended.

Electrical Specification MSC Timing 5 V Operation

- 4) The PLL jitter is not included. It should be considered additionally, corresponding to the used baudrate. The duty cycle can be adjusted if the ABRA block is used.
- 5) Positive deviation lengthens the high time and shortens the low time of a clock period. Negative deviation does the opposite.
- 6) From FCLP rising edge.
- 7) When using slow and asymmetrical edges, like in case of open drain upstream connection, the application must take care that the bit is long enough (the baud rate is low enough) so that under worst case conditions the three sampling points in the middle of the bit are not violated.

Timing Options for t_{45}

The wiring shown in the **Figure 3-22** provides three useful timing options for t_{45} . depending on the signals selected with the alternate output lines (ALT1 to ALT7) in the ports:

- EN01 - FCLN, SON, EN0, EN1 - t_{45} reference timing
- EN01D - FCLND, SOND, EN0, EN1 - t_{45} window shifted to the left
- EN23 - FCLN, SON, EN2, EN3 - t_{45} window shifted to the right

The timings corresponding to EN01, EN01D, and EN23 are defined in the LVDS mode. In order to use the EN23 timings, the application should use the EN2 and EN3 outputs of the MSC module.

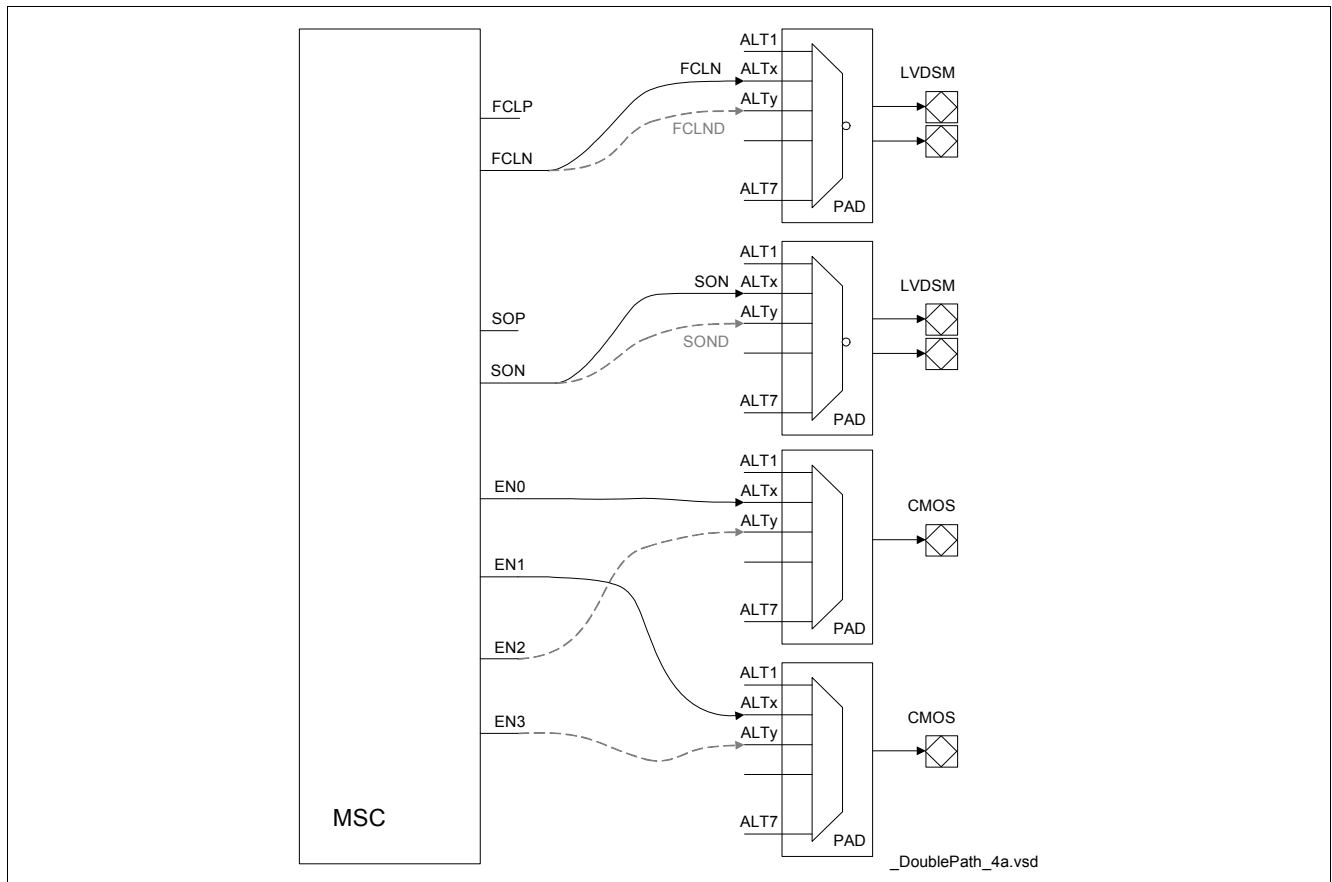

Figure 3-22 Timing Options for t_{45}

Mapping B, CMOS MP Pads

This timing applies for the dedicated CMOS pads, pin Mapping B:

- MP strong sharp (MPss) output pads for the clock and the data signals
- MP strong sharp or strong medium (MP+ss or MP+sm) output pads for enable signals

Table 3-76 MPss clock/data (LVDS pads in CMOS mode, option EN01)

Parameter	Symbol	Values			Unit	Note / Test Condition
		Min.	Typ.	Max.		
FCLPx clock period ¹⁾	t_{40} CC	$2 * T_A$ ^{2) 3)}	-	-	ns	MPss; $C_L=50pF$
Deviation from ideal duty cycle ^{4) 5)}	t_{400} CC	-2	-	$3+0.035 * C_L$	ns	MPss; $0 < C_L < 100pF$

Table 3-76 MPss clock/data (LVDS pads in CMOS mode, option EN01) (cont'd)

Parameter	Symbol	Values			Unit	Note / Test Condition
		Min.	Typ.	Max.		
SOPx output delay ⁶⁾	t_{44} CC	-4	-	7	ns	MPss; $C_L=50\text{pF}$
ENx output delay ⁶⁾	t_{45} CC	-6	-	7	ns	MP+ss/MPRss; $C_L=50\text{pF}$
		-2	-	16.5	ns	MP+sm/MPRsm; $C_L=50\text{pF}$
		-4	-	10	ns	MPss; $C_L=50\text{pF}$
		0	-	32	ns	MPsm; $C_L=50\text{pF}$; except pin P13.0
		0	-	32	ns	MPsm; $C_L=50\text{pF}$; pin P13.0
		5	-	45	ns	MPm/MP+m/MPRm; $C_L=50\text{pF}$
		-11	-	7.5	ns	MP+ss/MPRss; $C_L=0\text{pF}$
		-4	-	13	ns	MP+sm/MPRsm; $C_L=0\text{pF}$
		-10	-	7	ns	MPss; $C_L=0\text{pF}$
		-1	-	22	ns	MPsm; $C_L=0\text{pF}$
		-2	-	25	ns	MP+m/MPm/MPRm; $C_L=0\text{pF}$
SDI bit time	t_{46} CC	$8 * t_{MSC}$	-	-	ns	Upstream Timing
SDI rise time ⁷⁾	t_{48} SR	-	-	200	ns	Upstream Timing
SDI fall time ⁷⁾	t_{49} SR	-	-	200	ns	Upstream Timing

- 1) FCLP signal rise/fall times are the rise/fall times of the LVDSM pads, and the high/low times are $\min 1 * T_A$.
- 2) T_A depends on the clock source selected for baud rate generation in the ABRA block of the MSC.
- 3) FCLP signal high and low can be minimum $1 * T_{MSC}$.
- 4) The PLL jitter is not included. It should be considered additionally, corresponding to the used baudrate. The duty cycle can be adjusted if the ABRA block is used.
- 5) Positive deviation lengthens the high time and shortens the low time of a clock period. Negative deviation does the opposite.
- 6) From FCLP rising edge.
- 7) When using slow and asymmetrical edges, like in case of open drain upstream connection, the application must take care that the bit is long enough (the baud rate is low enough) so that under worst case conditions the three sampling points in the middle of the bit are not violated.

Table 3-77 MP+sm/MPRsm clock/data

Parameter	Symbol	Values			Unit	Note / Test Condition
		Min.	Typ.	Max.		
FCLPx clock period ¹⁾	t_{40} CC	$2 * T_A$	-	-	ns	MP+sm/MPRsm; $C_L=50\text{pF}$
Deviation from ideal duty cycle ^{2) 3)}	t_{400} CC	-3	-	$3+0.01 * C_L$	ns	MP+sm/MPRsm; $0 < C_L < 200\text{pF}$

Table 3-77 MP+sm/MPRsm clock/data (cont'd)

Parameter	Symbol	Values			Unit	Note / Test Condition
		Min.	Typ.	Max.		
SOPx output delay ⁴⁾	t_{44} CC	-5	-	7	ns	MP+sm; $C_L=50\text{pF}$
ENx output delay ⁴⁾	t_{45} CC	-13	-	2 ⁵⁾	ns	MPss; $C_L=50\text{pF}$
		-5	-	11	ns	MP+sm/MPRsm; $C_L=50\text{pF}$
		1	-	25	ns	MPsm; $C_L=50\text{pF}$
		3	-	37	ns	MP+m/MPm/MPRm; $C_L=50\text{pF}$
		-19	-	2	ns	MPss; $C_L=0\text{pF}$
		-13	-	8	ns	MP+sm; $C_L=0\text{pF}$
		-5	-	17	ns	MPsm; $C_L=0\text{pF}$
		-5	-	20	ns	MPm/MP+m/MPRm; $C_L=0\text{pF}$

- 1) FCLP signal rise/fall times are the rise/fall times of the LVDSM pads, and the high/low times are $\min 1 * T_A$.
- 2) The PLL jitter is not included. It should be considered additionally, corresponding to the used baudrate. The duty cycle can be adjusted if the ABRA block is used.
- 3) Positive deviation lengthens the high time and shortens the low time of a clock period. Negative deviation does the opposite.
- 4) From FCLP rising edge.
- 5) If EN1 is configured to P13.0 the max limit is increased by 0.5ns to 2.5ns.

Table 3-78 MPm/MP+m/MPRm clock/data

Parameter	Symbol	Values			Unit	Note / Test Condition
		Min.	Typ.	Max.		
FCLPx clock period ¹⁾	t_{40} CC	$2 * T_A$	-	-	ns	MPm/MP+m/MPRm; $C_L=50\text{pF}$
Deviation from ideal duty cycle ^{2) 3)}	t_{400} CC	-16	-	$4+0.04 * C_L$	ns	MPm/MP+m; $0 < C_L < 200\text{pF}$
SOPx output delay ⁴⁾	t_{44} CC	-11	-	20	ns	MPm/MP+m; $C_L=50\text{pF}$
ENx output delay ⁴⁾	t_{45} CC	-13	-	24	ns	MPm/MP+m/MPRm; $C_L=50\text{pF}$
		-33	-	17	ns	MPm/MP+m/MPRm; $C_L=0\text{pF}$

- 1) FCLP signal rise/fall times are the rise/fall times of the LVDSM pads, and the high/low times are $\min 1 * T_A$.
- 2) The PLL jitter is not included. It should be considered additionally, corresponding to the used baudrate. The duty cycle can be adjusted if the ABRA block is used.
- 3) Positive deviation lengthens the high time and shortens the low time of a clock period. Negative deviation does the opposite.
- 4) From FCLP rising edge.

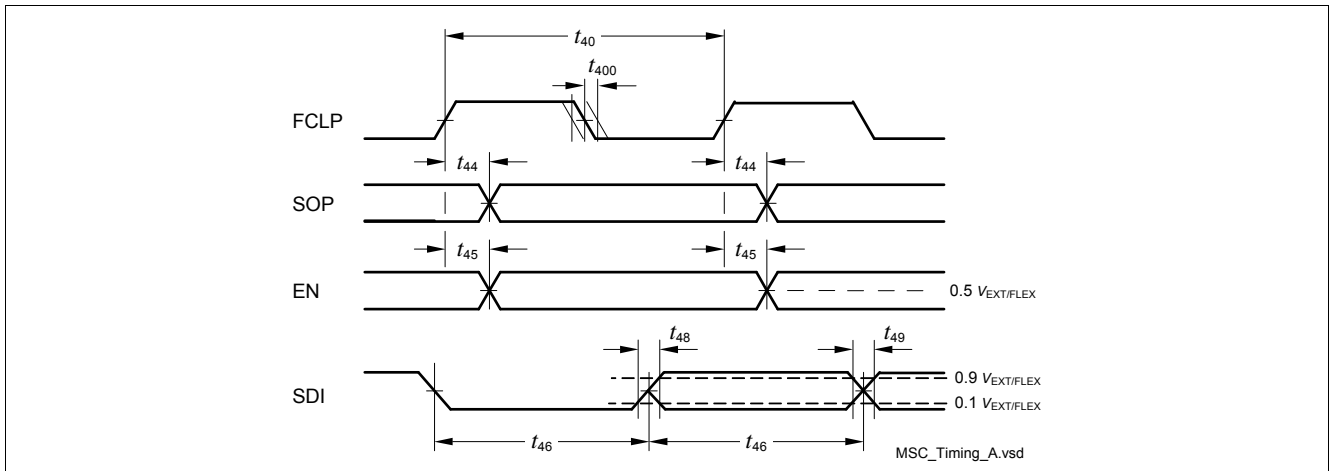
Figure 3-23 MSC Interface Timing

Note: The SOP data signal is sampled with the falling edge of FCLP in the target device.

3.27 MSC Timing 3.3 V Operation

The following section defines the timings for 3.3V pad power supply.

Mapping A, Combo Pads in LVDS Mode or CMOS Mode

The timing applies for the LVDS pads in LVDS operating mode:

- The LVDSM output pads for clock and data signals set in LVDS mode
- The CMOS MP pads for enable signals, with strong driver sharp edge (MPss) or strong driver medium edge (MPsm).

Table 3-79 LVDS clock/data (LVDS pads in LVDS mode)

Parameter	Symbol	Values			Unit	Note / Test Condition
		Min.	Typ.	Max.		
FCLPx clock period ¹⁾	t_{40} CC	$2 * T_A$ ^{2) 3)}	-	-	ns	LVDSM; $C_L=50\text{pF}$
Deviation from ideal duty cycle ^{4) 5)}	t_{400} CC	-2	-	2	ns	LVDSM; $0 < C_L < 50\text{pF}$
SOPx output delay ⁶⁾	t_{44} CC	-5	-	5	ns	LVDSM; $C_L=50\text{pF}$; option EN01
		-7	-	7	ns	LVDSM; $C_L=50\text{pF}$; option EN01D

Table 3-79 LVDS clock/data (LVDS pads in LVDS mode) (cont'd)

Parameter	Symbol	Values			Unit	Note / Test Condition
		Min.	Typ.	Max.		
ENx output delay ⁶⁾	t_{45} CC	-7	-	9.5	ns	MP+ss/MPRss; option EN01; $C_L=25\text{pF}$
		-5	-	13	ns	MP+ss/MPRss; option EN01; $C_L=50\text{pF}$
		-5	-	26	ns	MP+sm/MPRsm; option EN01D; $C_L=50\text{pF}$
		-4	-	16	ns	MP+ss/MPRss; option EN23; $C_L=25\text{pF}$
		-4	-	17	ns	MP+ss/MPRss; option EN23; $C_L=50\text{pF}$
		-5	-	19	ns	MPss; option EN01; $C_L=50\text{pF}$
		-12	-	5.5	ns	MP+ss/MPRss; option EN01; $C_L=0\text{pF}$
		-9	-	11	ns	MP+sm/MPRsm; option EN01D; $C_L=0\text{pF}$
		-7	-	9	ns	MP+ss/MPRss; option EN23; $C_L=0\text{pF}$
		-12	-	7	ns	MPss; option EN01; $C_L=0\text{pF}$
SDI bit time	t_{46} CC	$8 * t_{MSC}$	-	-	ns	Upstream Timing
SDI rise time ⁷⁾	t_{48} SR	-	-	200	ns	Upstream Timing
SDI fall time ⁷⁾	t_{49} SR	-	-	200	ns	Upstream Timing

1) FCLP signal rise/fall times are the rise/fall times of the LVDSM pads, and the high/low times are $\min 1 * T_A$.

2) $T_{Amin} = T_{MAX}$. When $T_{MAX} = 100 \text{ MHz}$, $t_{40} = 20 \text{ ns}$

3) The capacitive load on the LVDS pins is differential, the capacitive load on the CMOS pins is single ended.

4) The PLL jitter is not included. It should be considered additionally, corresponding to the used baudrate. The duty cycle can be adjusted if the ABRA block is used.

5) Positive deviation lengthens the high time and shortens the low time of a clock period. Negative deviation does the opposite.

6) From FCLP rising edge.

7) When using slow and asymmetrical edges, like in case of open drain upstream connection, the application must take care that the bit is long enough (the baud rate is low enough) so that under worst case conditions the three sampling points in the middle of the bit are not violated.

Mapping B, CMOS MP Pads

This timing applies for the dedicated CMOS pads, pin Mapping B:

- MP strong sharp (MPss) output pads for the clock and the data signals
- MP strong sharp or strong medium (MPss or MPsm) output pads for enable signals

Electrical Specification MSC Timing 3.3 V Operation

Table 3-80 MPss clock/data (LVDS pads in CMOS mode, option EN01)

Parameter	Symbol	Values			Unit	Note / Test Condition
		Min.	Typ.	Max.		
FCLPx clock period ¹⁾	t_{40} CC	$2 * T_A$ ^{2) 3)}	-	-	ns	MPss; $C_L=50\text{pF}$
Deviation from ideal duty cycle ^{4) 5)}	t_{400} CC	-5	-	$7+0.07 * C_L$	ns	MPss; $0 < C_L < 100\text{pF}$
SOPx output delay ⁶⁾	t_{44} CC	-7	-	12	ns	MPss; $C_L=50\text{pF}$
ENx output delay ⁶⁾	t_{45} CC	-9	-	12	ns	MP+ss/MPRss; $C_L=50\text{pF}$
		-4	-	26	ns	MP+sm/MPRsm; $C_L=50\text{pF}$
		-7	-	17	ns	MPss; $C_L=50\text{pF}$
		0	-	56	ns	MPsm; $C_L=50\text{pF}$; except pin P13.0
		0	-	58	ns	MPsm; $C_L=50\text{pF}$; pin P13.0
		4	-	77	ns	MPm/MP+m/MPRm; $C_L=50\text{pF}$
		-19	-	8	ns	MP+ss/MPRss; $C_L=0\text{pF}$
		-7	-	19	ns	MP+sm/MPRsm; $C_L=0\text{pF}$
		-17	-	8	ns	MPss; $C_L=0\text{pF}$
		-2	-	38	ns	MPsm; $C_L=0\text{pF}$
-4	-	41	ns	MP+m/MPm/MPRm; $C_L=0\text{pF}$		
SDI bit time	t_{46} CC	$8 * t_{MSC}$	-	-	ns	Upstream Timing
SDI rise time ⁷⁾	t_{48} SR	-	-	200	ns	Upstream Timing
SDI fall time ⁷⁾	t_{49} SR	-	-	200	ns	Upstream Timing

1) FCLP signal rise/fall times are the rise/fall times of the LVDSM pads, and the high/low times are $\min 1 * T_A$.

2) $T_{Amin} = T_{MAX}$. When $T_{MAX} = 100 \text{ MHz}$, $t_{40} = 20 \text{ ns}$

3) FCLP signal high and low can be minimum $1 * T_{MSC}$.

4) The PLL jitter is not included. It should be considered additionally, corresponding to the used baudrate. The duty cycle can be adjusted if the ABRA block is used.

5) Positive deviation lengthens the high time and shortens the low time of a clock period. Negative deviation does the opposite.

6) From FCLP rising edge.

7) When using slow and asymmetrical edges, like in case of open drain upstream connection, the application must take care that the bit is long enough (the baud rate is low enough) so that under worst case conditions the three sampling points in the middle of the bit are not violated.

Electrical Specification MSC Timing 3.3 V Operation

Table 3-81 MP+sm/MPRsm clock/data

Parameter	Symbol	Values			Unit	Note / Test Condition
		Min.	Typ.	Max.		
FCLPx clock period ¹⁾	t_{40} CC	$2 * T_A$	-	-	ns	MP+sm/MPRsm; $C_L=50\text{pF}$
Deviation from ideal duty cycle ^{2) 3)}	t_{400} CC	-6	-	7	ns	MP+sm/MPRsm; $0 < C_L < 200\text{pF}$
SOPx output delay ⁴⁾	t_{44} CC	-9	-	12	ns	MP+sm; $C_L=50\text{pF}$
ENx output delay ⁴⁾	t_{45} CC	-20	-	4	ns	MPss; $C_L=50\text{pF}$
		-9	-	19	ns	MP+sm/MPRsm; $C_L=50\text{pF}$
		0	-	44	ns	MPsm; $C_L=50\text{pF}$
		0	-	63	ns	MP+m/MPm/MPRm; $C_L=50\text{pF}$
		-33	-	0	ns	MPss; $C_L=0\text{pF}$
		-23	-	9	ns	MP+sm/MPRsm; $C_L=0\text{pF}$
		-9	-	28	ns	MPsm; $C_L=0\text{pF}$
		-9	-	31	ns	MPm/MP+m/MPRm; $C_L=0\text{pF}$

- 1) FCLP signal rise/fall times are the rise/fall times of the LVDSM pads, and the high/low times are $\min 1 * T_A$.
- 2) The PLL jitter is not included. It should be considered additionally, corresponding to the used baudrate. The duty cycle can be adjusted if the ABRA block is used.
- 3) Positive deviation lengthens the high time and shortens the low time of a clock period. Negative deviation does the opposite.
- 4) From FCLP rising edge.

Table 3-82 MPm/MP+m/MPRm clock/data

Parameter	Symbol	Values			Unit	Note / Test Condition
		Min.	Typ.	Max.		
FCLPx clock period ¹⁾	t_{40} CC	$2 * T_A$	-	-	ns	MPm/MP+m/MPRm; $C_L=50\text{pF}$
Deviation from ideal duty cycle ^{2) 3)}	t_{400} CC	$-6-0.95 * C_L$	-	$6+0.07 * C_L$	ns	MPm/MP+m/MPRm; $0 < C_L < 200\text{pF}$
SOPx output delay ⁴⁾	t_{44} CC	-19	-	34	ns	MPm/MP+m; $C_L=50\text{pF}$
ENx output delay ⁴⁾	t_{45} CC	-19	-	38	ns	MPm/MP+m/MPRm; $C_L=50\text{pF}$
		-57	-	27	ns	MPm/MP+m/MPRm; $C_L=0\text{pF}$

- 1) FCLP signal rise/fall times are the rise/fall times of the LVDSM pads, and the high/low times are $\min 1 * T_A$.
- 2) The PLL jitter is not included. It should be considered additionally, corresponding to the used baudrate. The duty cycle can be adjusted if the ABRA block is used.
- 3) Positive deviation lengthens the high time and shortens the low time of a clock period. Negative deviation does the opposite.

4) From FCLP rising edge.

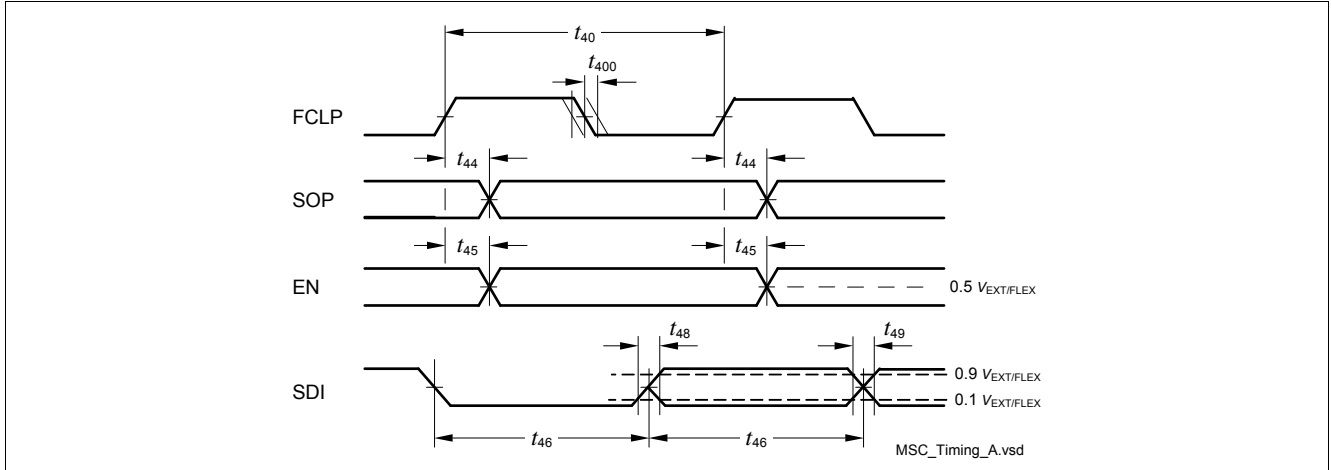

Figure 3-24 MSC Interface Timing

Note: The SOP data signal is sampled with the falling edge of FCLP in the target device.

3.28 Ethernet Interface (ETH) Characteristics

3.28.1 ETH Measurement Reference Points

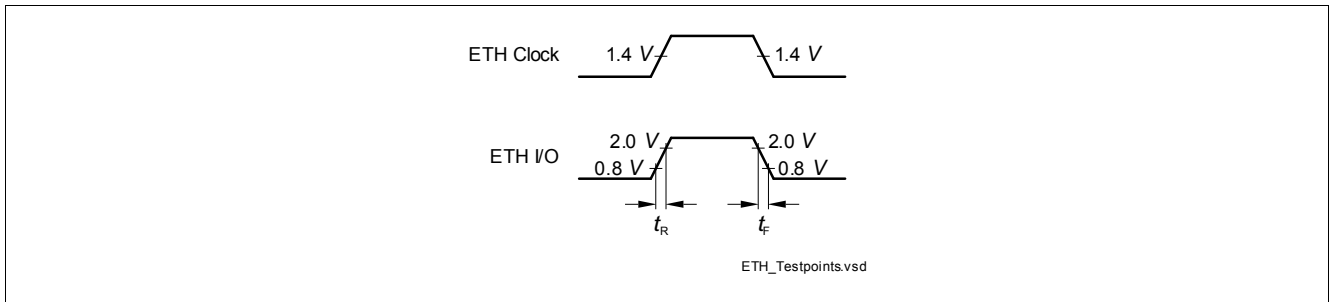

Figure 3-25 ETH Measurement Reference Points

3.28.2 ETH Management Signal Parameters (ETH_MDC, ETH_MDIO)

Table 3-83 ETH Management Signal Parameters

Parameter	Symbol	Values			Unit	Note / Test Condition
		Min.	Typ.	Max.		
ETH_MDC period	t_1 CC	400	-	-	ns	$C_L=25\text{pF}$
ETH_MDC high time	t_2 CC	160	-	-	ns	$C_L=25\text{pF}$
ETH_MDC low time	t_3 CC	160	-	-	ns	$C_L=25\text{pF}$
ETH_MDIO setup time (output)	t_4 CC	10	-	-	ns	$C_L=25\text{pF}$
ETH_MDIO hold time (output)	t_5 CC	10	-	-	ns	$C_L=25\text{pF}$
ETH_MDIO data valid (input)	t_6 SR	0	-	300	ns	$C_L=25\text{pF}$

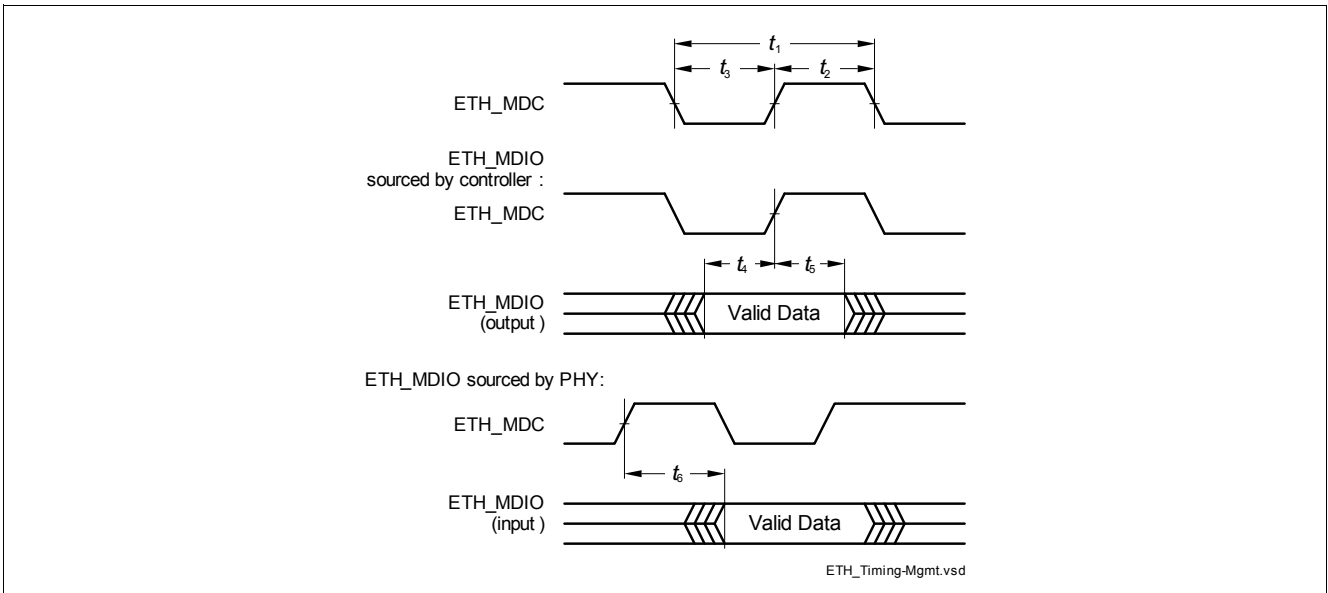

Figure 3-26 ETH Management Signal Timing

Electrical Specification Ethernet Interface (ETH) Characteristics

3.28.3 ETH MII Parameters

In the following, the parameters of the MII (Media Independent Interface) are described.

Table 3-84 ETH MII Signal Timing Parameters

Parameter	Symbol	Values			Unit	Note / Test Condition
		Min.	Typ.	Max.		
Clock period	t_7 SR	40	-	-	ns	$C_L=25\text{pF}$; baudrate=100Mbps
		400	-	-	ns	$C_L=25\text{pF}$; baudrate=10Mbps
Clock high time	t_8 SR	14	-	26	ns	$C_L=25\text{pF}$; baudrate=100Mbps
		140 ¹⁾	-	260 ²⁾	ns	$C_L=25\text{pF}$; baudrate=10Mbps
Clock low time	t_9 SR	14	-	26	ns	$C_L=25\text{pF}$; baudrate=100Mbps
		140 ¹⁾	-	260 ²⁾	ns	$C_L=25\text{pF}$; baudrate=10Mbps
Input setup time	t_{10} SR	10	-	-	ns	$C_L=25\text{pF}$
Input hold time	t_{11} SR	10	-	-	ns	$C_L=25\text{pF}$
Output valid time	t_{12} CC	0	-	25	ns	$C_L=25\text{pF}$

1) Defined by 35% of clock period.

2) Defined by 65% of clock period.

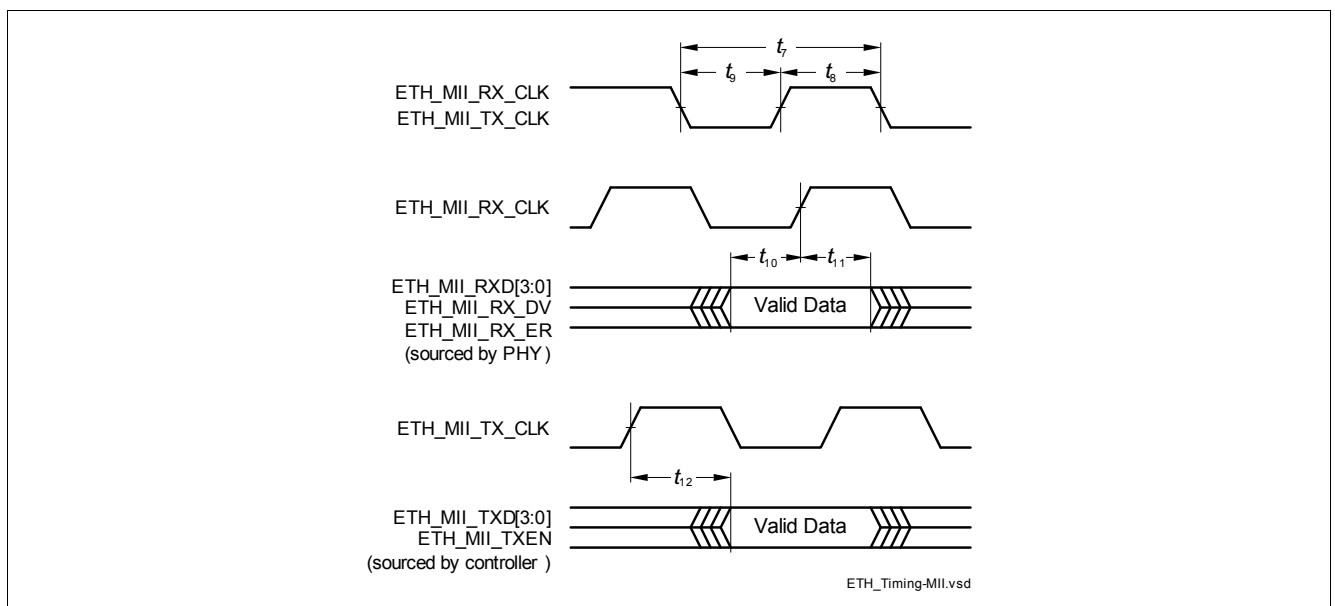
Figure 3-27 ETH MII Signal Timing

3.28.4 ETH RMII Parameters

In the following, the parameters of the RMII (Reduced Media Independent Interface) are described.

Table 3-85 ETH RMII Signal Timing Parameters

Parameter	Symbol	Values			Unit	Note / Test Condition
		Min.	Typ.	Max.		
ETH_RMII_REF_CL clock period	t_{13} CC	20	-	-	ns	$C_L=25\text{pF}$; 50ppm
ETH_RMII_REF_CL clock high time	t_{14} CC	7 ¹⁾	-	13 ²⁾	ns	$C_L=25\text{pF}$
ETH_RMII_REF_CL clock low time	t_{15} CC	7 ¹⁾	-	13 ²⁾	ns	$C_L=25\text{pF}$
ETHTXEN, ETHTXD[1:0], ETHRXD[1:0], ETHCRSDV, ETHRXER; setup time	t_{16} CC	4	-	-	ns	$C_L=25\text{pF}$
ETHTXEN, ETHTXD[1:0], ETHRXD[1:0], ETHCRSDV, ETHRXER; hold time	t_{17} CC	2	-	-	ns	$C_L=25\text{pF}$

1) Defined by 35% of clock period.

2) Defined by 65% of clock period.

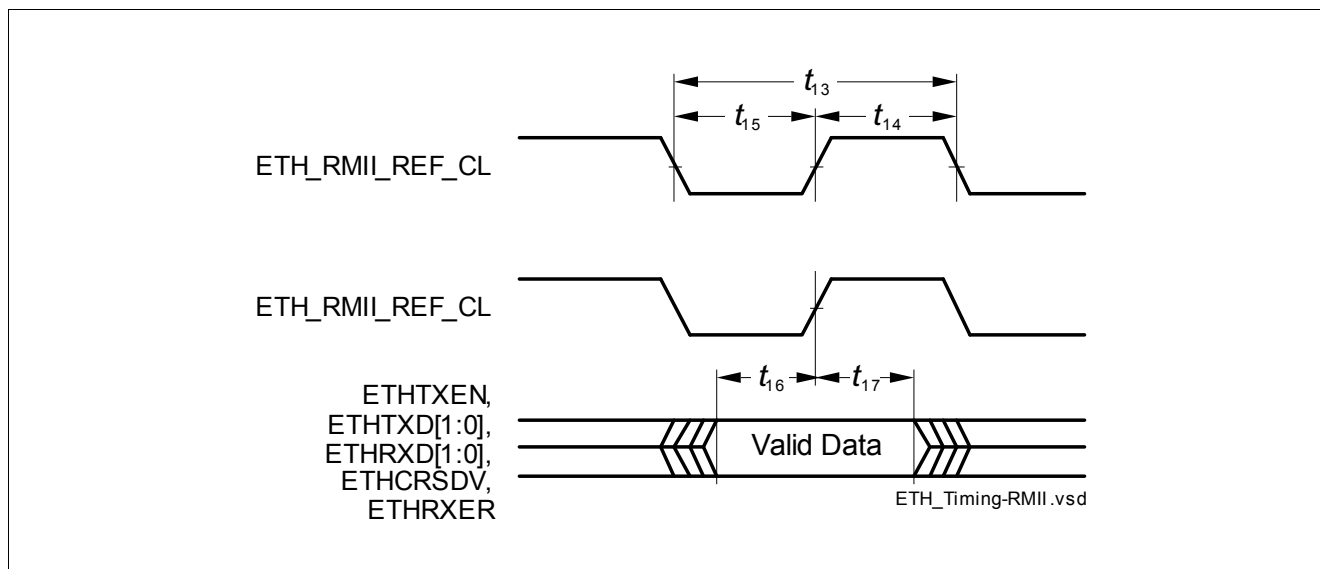

Figure 3-28 ETH RMII Signal Timing

3.29 E-Ray Parameters

The timings of this section are valid for the strong driver and either sharp edge settings of the output drivers with $C_L = 25$ pF. For the inputs the hysteresis has to be configured to inactive.

Table 3-86 Transmit Parameters

Parameter	Symbol	Values			Unit	Note / Test Condition
		Min.	Typ.	Max.		
Rise time of TxEN	$t_{dCCTxENRise25CC}$	-	-	9	ns	$C_L=25pF$
Fall time of TxEN	$t_{dCCTxENFall25CC}$	-	-	9	ns	$C_L=25pF$
Sum of rise and fall time	$t_{dCCTxRise25+dCCTxFall25CC}$	-	-	9	ns	20% - 80%; $C_L=25pF$
Sum of delay between TP1_FF and TP1_CC and delays derived from TP1_FFi, rising edge of TxEN	$t_{dCCTxEN01CC}$	-	-	25	ns	
Sum of delay between TP1_FF and TP1_CC and delays derived from TP1_FFi, falling edge of TxEN	$t_{dCCTxEN10CC}$	-	-	25	ns	
Asymmetry of sending	$t_{tx_asym} CC$	-2.45	-	2.45	ns	$C_L=25pF$
Sum of delay between TP1_FF and TP1_CC and delays derived from TP1_FFi, rising edge of TxD	$t_{dCCTxD01CC}$	-	-	25	ns	
Sum of delay between TP1_FF and TP1_CC and delays derived from TP1_FFi, falling edge of TxD	$t_{dCCTxD10CC}$	-	-	25	ns	
TxD signal sum of rise and fall time at TP1_BD	$t_{txd_sum} CC$	-	-	9	ns	

Table 3-87 Receive Parameters

Parameter	Symbol	Values			Unit	Note / Test Condition
		Min.	Typ.	Max.		
Acceptance of asymmetry at receiving part	$t_{dCCTxAsymAccept25SR}$	-30.5	-	43.0	ns	$C_L=25pF$
Acceptance of asymmetry at receiving part	$t_{dCCTxAsymAccept15SR}$	-31.5	-	44.0	ns	$C_L=15pF$
Threshold for detecting logical high	$T_{uCCLogic1SR}$	35	-	70	%	
Threshold for detecting logical low	$T_{uCCLogic0SR}$	30	-	65	%	

Table 3-87 Receive Parameters (cont'd)

Parameter	Symbol	Values			Unit	Note / Test Condition
		Min.	Typ.	Max.		
Sum of delay between TP4_CC and TP4_FF and delays derived from TP4_FFi, rising edge of RxD	$t_{dCCRxD01}$ CC	-	-	10	ns	
Sum of delay between TP1_CC and TP1_CC and delays derived from TP4_FFi, falling edge of RxD	$t_{dCCRxD10}$ CC	-	-	10	ns	

3.30 HSCT Parameters

Table 3-88 HSCT - Rx/Tx setup timing

Parameter	Symbol	Values			Unit	Note / Test Condition
		Min.	Typ.	Max.		
RX o/p duty cycle	DC_{rx} CC	40	-	60	%	
Bias startup time	t_{bias} CC	-	5	10	μ s	Bias distributor waking up from power down and provide stable Bias.
RX startup time	t_{rx} CC	-	5	-	μ s	Wake-up RX from power down.
TX startup time	t_{tx} CC	-	5	-	μ s	Wake-up TX from power down.

Table 3-89 HSCT - Rx parasitics and loads

Parameter	Symbol	Values			Unit	Note / Test Condition
		Min.	Typ.	Max.		
Capacitance total budget	C_{total} CC	-	3.5	5	pF	Total Budget for complete receiver including silicon, package, pins and bond wire
Parasitic inductance budget	H_{total} CC	-	5	-	nH	

Table 3-90 LVDSH - Reduced TX and RX (RED)

Parameter	Symbol	Values			Unit	Note / Test Condition
		Min.	Typ.	Max.		
Output differential voltage	V_{OD} CC	150	200	285	mV	$R_t = 100 \text{ Ohm } \pm 20\%$ @2pF
Output voltage high	V_{OH} CC	-	-	1463	mV	$R_t = 100 \text{ Ohm } \pm 20\%$
Output voltage low	V_{OL} CC	937	-	-	mV	$R_t = 100 \text{ Ohm } \pm 20\%$
Output offset (Common mode) voltage	V_{OS} CC	1.08	1.2	1.32	V	$R_t = 100 \text{ Ohm } \pm 20\%$ @2pF
Input voltage range	V_I SR	-	-	1.6	V	Absolute max = $1.6 \text{ V} + (285\text{mV}/2) = 1.743$
		0.15	-	-	V	Absolute min = $0.15 \text{ V} - (285 \text{ mV} / 2) = 0 \text{ V}$
Input differential threshold	V_{idth} SR	-100	-	100	mV	100 mV for 55% of bit period; Note Absolute Value ($V_{idth} - V_{idthl}$)
Data frequency	DR CC	5	-	320	Mbps	

Table 3-90 LVDSH - Reduced TX and RX (RED) (cont'd)

Parameter	Symbol	Values			Unit	Note / Test Condition
		Min.	Typ.	Max.		
Receiver differential input impedance	R_{in} CC	90	100	110	Ohm	$0\text{ V} < V_I < 1.6\text{V}$
		80	100	120	Ohm	$1.6\text{ V} < V_I < 2.0\text{V}$
Slew rate	SR_{tx} CC	-	-	2	V/ns	
Change in VOS between 0 and 1	$dVOS$ CC	-	-	50	mV	Peak to peak (including DC transients).
Change in Vod between 0 and 1	$dVod$ CC	-	-	50	mV	Peak to peak (including DC transients)
Fall time ¹⁾	t_{fall} CC	0.26	-	1.2	ns	$R_t = 100\text{ Ohm} \pm 20\%$ @2pF
Rise time ¹⁾	t_{rise} CC	0.26	-	1.2	ns	$R_t = 100\text{ Ohm} \pm 20\%$ @2pF

1) Rise / fall times are defined for 10% - 90% of V_{OD}

Table 3-91 HSCT PLL

Parameter	Symbol	Values			Unit	Note / Test Condition
		Min.	Typ.	Max.		
PLL frequency range	f_{PLL} CC	12.5	320	320	MHz	
PLL input frequency	f_{REF} CC	10	-	20	MHz	
PLL lock-in time	t_{LOCK} CC	-	-	50	μs	
Bit Error Rate based on 10 MHz reference clock at Slave PLL side	BER_{10} CC	-	-	10EXP-9	-	Bit Error Rate based on Slave interface reference clock at 10 MHz
Bit Error Rate based on 20 MHz reference clock at Slave PLL side	BER_{20} CC	-	-	10EXP-12	-	Bit Error Rate based on Slave interface reference clock at 20 MHz
Absolute RMS Jitter (TX out)	J_{ABS10} CC	-125	-	125	ps	Measured at link TX out; valid for Reference frequency at 10 MHz
Absolute RMS Jitter (TX out)	J_{ABS20} CC	-85	-	85	ps	Measured at link TX out; valid for Reference frequency at 20 MHz

Table 3-91 HSCT PLL (cont'd)

Parameter	Symbol	Values			Unit	Note / Test Condition
		Min.	Typ.	Max.		
Accumulated RMS Jitter (RX side)	J_{ACC10} CC	-	-	145	ps	Measured at link RX input, based on 5000 measures, each 300 clock cycles; valid for Reference frequency at 10 MHz
Accumulated RMS Jitter (link RX side)	J_{ACC20} CC	-	-	115	ps	Measured at link RX input, based on 5000 measures, each 300 clock cycles; valid for Reference frequency at 20 MHz
Total Jitter peak to peak	TJ_{pp} CC	-	-	2083	ps	Total Jitter as sum of deterministic jitter and random jitter

Table 3-92 HSCT Sysclk

Parameter	Symbol	Values			Unit	Note / Test Condition
		Min.	Typ.	Max.		
Frequency	f_{SYSCLK} CC	10	-	20	MHz	
Frequency error	$dfERR$ CC	-1	-	1	%	
Duty Cycle	DC_{sys} CC	45	-	55	%	
Load impedance	R_{LOAD} CC	10	-	-	kOhm	
Load capacitance	C_{LOAD} CC	-	-	10	pF	
Integrated phase noise	I_{PN} CC	-	-	-58	dB	single sideband phase noise in 10 kHz to 10 Mhz at 20 MHz SysClk

3.31 Inter-IC (I2C) Interface Timing

This section defines the timings for I2C in the TC290 / TC297 / TC298 / TC299.

All I2C timing parameter are SR for Master Mode and CC for Slave Mode.

Table 3-93 I2C Standard Mode Timing

Parameter	Symbol	Values			Unit	Note / Test Condition
		Min.	Typ.	Max.		
Fall time of both SDA and SCL	t_1	-	-	300	ns	Measured with a pull-up resistor of 4.7 kohms at each of the SCL and SDA line
Capacitive load for each bus line	C_b SR	-	-	400	pF	
Bus free time between a STOP and ATART condition	t_{10}	4.7	-	-	μ s	Measured with a pull-up resistor of 4.7 kohms at each of the SCL and SDA line
Rise time of both SDA and SCL	t_2	-	-	1000	ns	Measured with a pull-up resistor of 4.7 kohms at each of the SCL and SDA line
Data hold time	t_3	0	-	-	μ s	Measured with a pull-up resistor of 4.7 kohms at each of the SCL and SDA line
Data set-up time	t_4	250	-	-	ns	Measured with a pull-up resistor of 4.7 kohms at each of the SCL and SDA line
Low period of SCL clock	t_5	4.7	-	-	μ s	Measured with a pull-up resistor of 4.7 kohms at each of the SCL and SDA line
High period of SCL clock	t_6	4	-	-	μ s	Measured with a pull-up resistor of 4.7 kohms at each of the SCL and SDA line
Hold time for the (repeated) START condition	t_7	4	-	-	μ s	Measured with a pull-up resistor of 4.7 kohms at each of the SCL and SDA line

Electrical Specification Inter-IC (I2C) Interface Timing

Table 3-93 I2C Standard Mode Timing (cont'd)

Parameter	Symbol	Values			Unit	Note / Test Condition
		Min.	Typ.	Max.		
Set-up time for (repeated) START condition	t_8	4.7	-	-	μs	Measured with a pull-up resistor of 4.7 kohms at each of the SCL and SDA line
Set-up time for STOP condition	t_9	4	-	-	μs	Measured with a pull-up resistor of 4.7 kohms at each of the SCL and SDA line

Table 3-94 I2C Fast Mode Timing

Parameter	Symbol	Values			Unit	Note / Test Condition
		Min.	Typ.	Max.		
Fall time of both SDA and SCL	t_1	$20+0.1 \cdot C_b$	-	300	ns	Measured with a pull-up resistor of 4.7 kohms at each of the SCL and SDA line
Capacitive load for each bus line	C_b SR	-	-	400	pF	
Bus free time between a STOP and ATART condition	t_{10}	1.3	-	-	μs	Measured with a pull-up resistor of 4.7 kohms at each of the SCL and SDA line
Rise time of both SDA and SCL	t_2	$20+0.1 \cdot C_b$	-	300	ns	Measured with a pull-up resistor of 4.7 kohms at each of the SCL and SDA line
Data hold time	t_3	0	-	-	μs	Measured with a pull-up resistor of 4.7 kohms at each of the SCL and SDA line
Data set-up time	t_4	100	-	-	ns	Measured with a pull-up resistor of 4.7 kohms at each of the SCL and SDA line
Low period of SCL clock	t_5	1.3	-	-	μs	Measured with a pull-up resistor of 4.7 kohms at each of the SCL and SDA line
High period of SCL clock	t_6	0.6	-	-	μs	Measured with a pull-up resistor of 4.7 kohms at each of the SCL and SDA line

Electrical Specification Inter-IC (I2C) Interface Timing

Table 3-94 I2C Fast Mode Timing (cont'd)

Parameter	Symbol	Values			Unit	Note / Test Condition
		Min.	Typ.	Max.		
Hold time for the (repeated) START condition	t_7	0.6	-	-	μs	Measured with a pull-up resistor of 4.7 kohms at each of the SCL and SDA line
Set-up time for (repeated) START condition	t_8	0.6	-	-	μs	Measured with a pull-up resistor of 4.7 kohms at each of the SCL and SDA line
Set-up time for STOP condition	t_9	0.6	-	-	μs	Measured with a pull-up resistor of 4.7 kohms at each of the SCL and SDA line

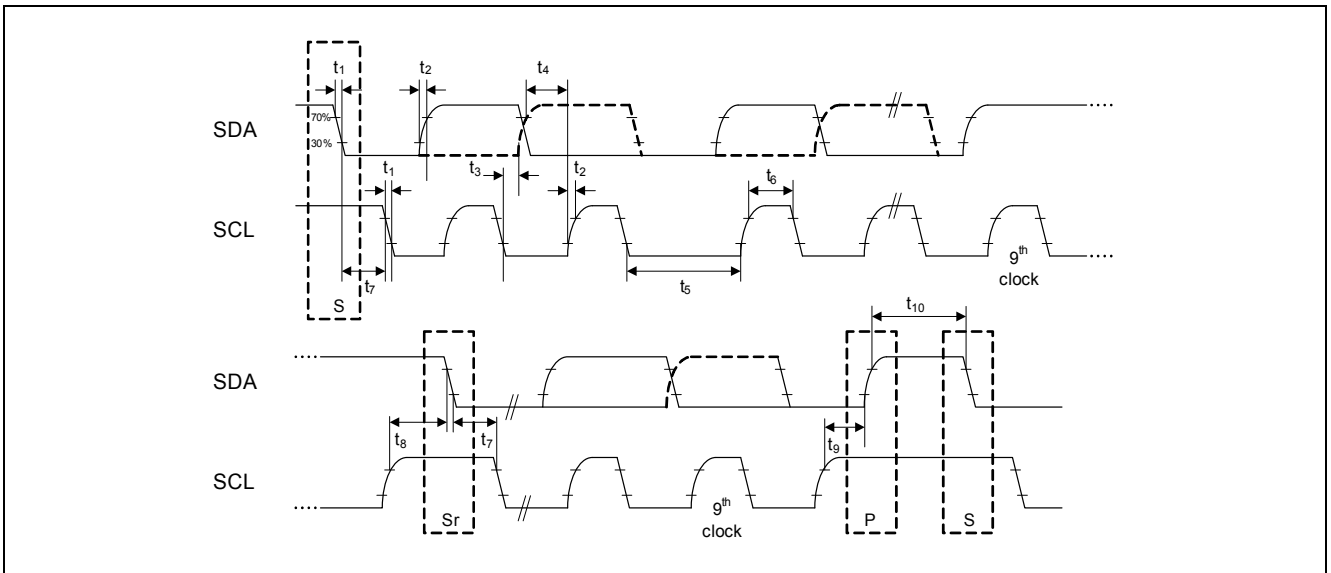

Figure 3-29 I2C Standard and Fast Mode Timing

3.32 EBU Timings

3.32.1 BFCLKO Output Clock Timing

$V_{SS} = 0\text{ V}; V_{DD} = 1.3\text{ V} \pm 5\%$; $V_{DDEBU} = 2.5\text{ V} \pm 5\%$ and $3.3\text{ V} \pm 5\%$;
 $C_L = 35\text{ pF}$

Table 3-95 BFCLKO Output Clock Timing Parameters¹⁾

Parameter	Symbol	Values			Unit	Note / Test Condition
		Min.	Typ.	Max.		
BFCLKO clock period	t_{BFCLKO} CC	13.33 ²⁾	–	–	ns	–
BFCLKO high time	t_5 CC	3	–	–	ns	–
BFCLKO low time	t_6 CC	3	–	–	ns	–
BFCLKO rise time	t_7 CC	–	–	3	ns	–
BFCLKO fall time	t_8 CC	–	–	3	ns	–
BFCLKO duty cycle $t_5/(t_5 + t_6)^3$	DC	35	50	55	%	–

- 1) Not subject to production test, verified by design/characterization.
- 2) The PLL jitter characteristics add to this value according to the application settings. See the PLL jitter parameters.
- 3) The PLL jitter is not included in this parameter. If the BFCLKO frequency is equal to f_{CPU} , the K divider has to be regarded.

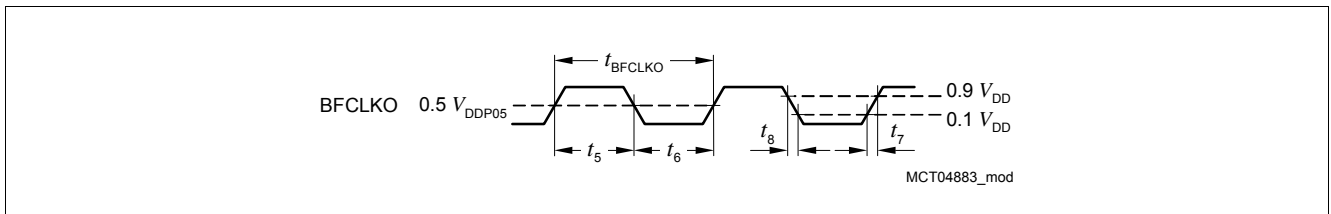

Figure 3-30 BFCLKO Output Clock Timing

3.32.2 EBU Asynchronous Timings

$V_{SS} = 0\text{ V}; V_{DD} = 1.3\text{ V} \pm 5\%$; $V_{DDEBU} = 2.5\text{ V} \pm 5\%$ and $3.3\text{ V} \pm 5\%$, Class B pins;
 $C_L = 35\text{ pF}$ for address/data; $C_L = 40\text{ pF}$ for the control lines.

For each timing, the accumulated PLL jitter of the programmed duration in number of clock periods must be added separately. Operating conditions apply and $C_L = 35\text{ pF}$.

Table 3-96 Common Asynchronous Timings

Parameter	Symbol	Values			Unit	Note / Test Condition
		Min.	Typ.	Max.		
AD(31:0) output delay to ADV# rising edge, multiplexed read / write	t_{13} CC	-5.5	-	2	ns	
AD(31:0) output delay to ADV# rising edge, multiplexed read / write	t_{14} CC	-5.5	-	2	ns	

Table 3-96 Common Asynchronous Timings (cont'd)

Parameter	Symbol	Values			Unit	Note / Test Condition
		Min.	Typ.	Max.		
Address valid to CS falling edge (deviation from programmed value)	t_{15} CC	-2	-	2	ns	
Address valid -> ADV falling edge (deviation from programmed value)	t_{16} CC	-2	-	2	ns	
ADV falling edge -> CS falling edge (deviation from programmed value)	t_{17} CC	-2	-	2	ns	
Pulse width deviation from the ideal programmed width due to pad asymmetry, rise delay - fall delay	t_a CC	-0.8	-	0.8	ns	edge=medium
		-0.8	-	0.8	ns	edge=sharp

Table 3-97 Asynchronous Read Timings

Parameter	Symbol	Values			Unit	Note / Test Condition
		Min.	Typ.	Max.		
A(23:0) output delay to \overline{RD} rising edge, deviation from the ideal programmed value	t_0 CC	-2.5	-	2.5	ns	
AD(31:0) output delay to ADV# rising edge, multiplexed read / write	t_{13} CC	-2.5	-	10	ns	
AD(31:0) output delay to ADV# rising edge, multiplexed read / write	t_{14} CC	-2.5	-	10	ns	
Data input Hold from CS rising edge	t_{18} CC	-4	-	-	ns	
Data input Setup to CS rising edge	t_{19} CC	12	-	-	ns	
A(23:0) output delay to RD rising edge, deviation from the ideal programmed value	t_1 CC	-2.5	-	2.5	ns	
CS rising edge to RD rising edge, deviation from the ideal programmed value	t_2 CC	-2	-	2.5	ns	
ADV rising edge to RD rising edge, deviation from the ideal programmed value	t_3 CC	-1.5	-	4.5	ns	
BC rising edge to RD rising edge, deviation from the ideal programmed value	t_4 CC	-2.5	-	2.5	ns	

Table 3-97 Asynchronous Read Timings (cont'd)

Parameter	Symbol	Values			Unit	Note / Test Condition
		Min.	Typ.	Max.		
WAIT input setup to RD rising edge	t_5 SR	12	-	-	ns	
WAIT input hold to RD rising edge	t_6 SR	0	-	-	ns	
Data input setup to RD rising edge	t_7 SR	12	-	-	ns	
Data input hold to RD rising edge	t_8 SR	0	-	-	ns	
MR / W output delay to RD# rising edge, deviation from the ideal programmed value	t_9 CC	-2.5	-	1.5	ns	

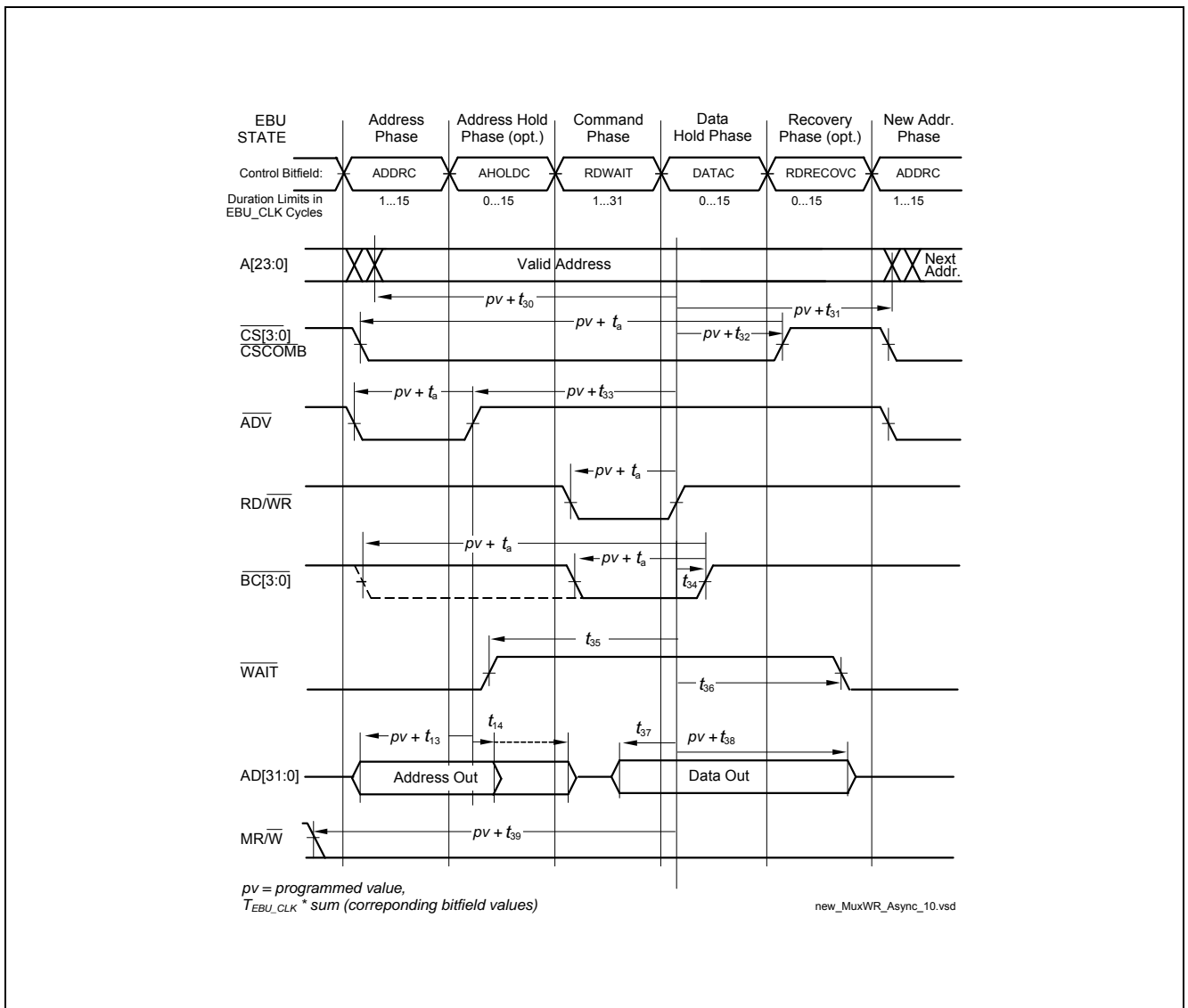

Figure 3-31 Multiplexed Read Access

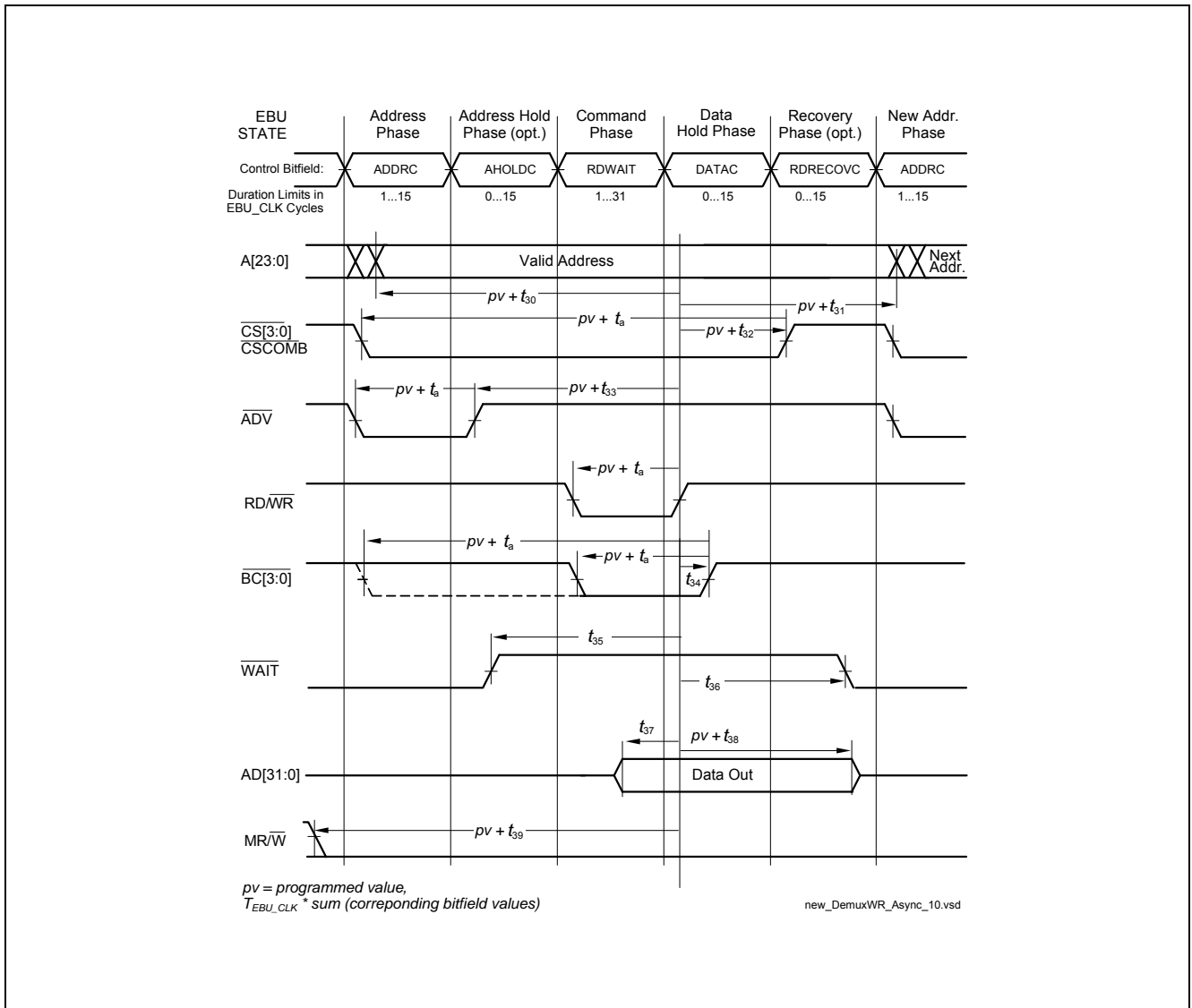

Figure 3-32 Demultiplexed Read Access

Table 3-98 Asynchronous Write Timings

Parameter	Symbol	Values			Unit	Note / Test Condition
		Min.	Typ.	Max.		
A(23:0) output delay to WR rising edge, deviation from the ideal programmed value	t_{30} CC	-2.5	-	2.5	ns	
A(23:0) output delay to WR rising edge, deviation from the ideal programmed value	t_{31} CC	-2.5	-	2.5	ns	
CS rising edge to WR rising edge, deviation from the ideal programmed value	t_{32} CC	-2	-	2	ns	

Table 3-98 Asynchronous Write Timings (cont'd)

Parameter	Symbol	Values			Unit	Note / Test Condition
		Min.	Typ.	Max.		
ADV rising edge to WR rising edge, deviation from the ideal programmed value	t_{33} CC	-2.5	-	2	ns	
BC rising edge to WR rising edge, deviation from the ideal programmed value	t_{34} CC	-2.5	-	2	ns	
WAIT input setup to WR rising edge, deviation from the ideal programmed value	t_{35} SR	12	-	-	ns	
WAIT input hold to WR rising edge, deviation from the ideal programmed value	t_{36} CC	0	-	-	ns	
Data output delay to WR rising edge, deviation from the ideal programmed value	t_{37} CC	-5.5	-	10	ns	
Data output delay to WR rising edge, deviation from the ideal programmed value	t_{38} CC	-5.5	-	2	ns	
MR / W output delay to WR rising edge, deviation from the ideal programmed value	t_{39} CC	-2.5	-	1.5	ns	

3.32.3 EBU Burst Mode Access Timing

$V_{SS} = 0\text{ V}$; $V_{DD} = 1.3\text{ V} \pm 5\%$; $V_{DDEBU} = 2.5\text{ V} \pm 5\%$ and $3.3\text{ V} \pm 5\%$;
 $C_L = 35\text{ pF}$;

Table 3-99 Burst Read Timings

Parameter	Symbol	Values			Unit	Note / Test Condition
		Min.	Typ.	Max.		
Output delay from BFCLKO rising edge	t_{10} CC	-2	-	2	ns	
D(31:0) Output delay from BFCLKO rising edge	t_{10a} CC	-2	-	10	ns	
RD and RD/WR active/inactive after BFCLKO active edge	t_{12} CC	-2	-	2	ns	
CSx output delay from BFCLKO active edge	t_{21} CC	-2.5	-	1.5	ns	
ADV active/inactive after BFCLKO active edge	t_{22} CC	-2	-	2	ns	
BAA active/inactive after BFCLKO active edge	t_{22a} CC	-2.5	-	4.5	ns	
Data setup to BFCLKI rising edge	t_{23} SR	3	-	-	ns	

Table 3-99 Burst Read Timings (cont'd)

Parameter	Symbol	Values			Unit	Note / Test Condition
		Min.	Typ.	Max.		
Data hold from BFCLKI rising edge	t_{24} SR	0	-	-	ns	
WAIT setup (low or high) to BFCLKI rising edge	t_{25} SR	3	-	-	ns	
WAIT hold (low or high) from BFCLKI rising edge	t_{26} SR	0	-	-	ns	

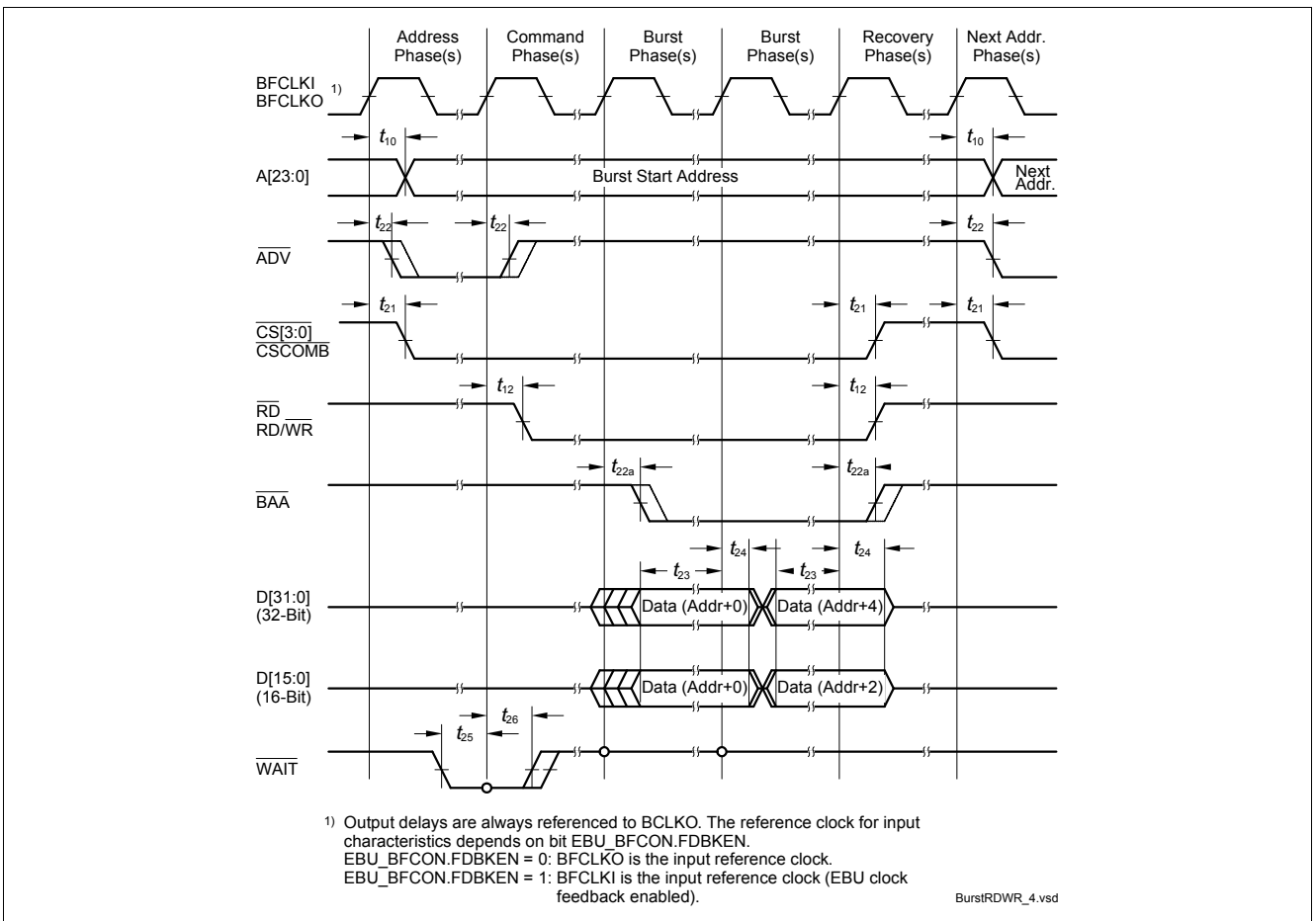

Figure 3-33 EBU Burst Mode Read / Write Access Timing

3.32.4 EBU Arbitration Signal Timing

$V_{SS} = 0\text{ V}; V_{DD} = 1.5\text{ V} \pm 5\%; V_{DDEBU} = 2.5\text{ V} \pm 5\%$ and $3.3\text{ V} \pm 5\%$;
 $T_A = -40^\circ\text{C}$ to $+125^\circ\text{C}; C_L = 35\text{ pF}$;

Table 3-100 EBU Arbitration Timings

Parameter	Symbol	Values			Unit	Note / Test Condition
		Min.	Typ.	Max.		
Output delay from BFCLKO rising edge	t_{27} CC	-	-	4.5	ns	
Data setup to BFCLKO falling edge	t_{28} SR	15	-	-	ns	
Data hold from BFCLKO falling edge	t_{29} SR	2	-	-	ns	

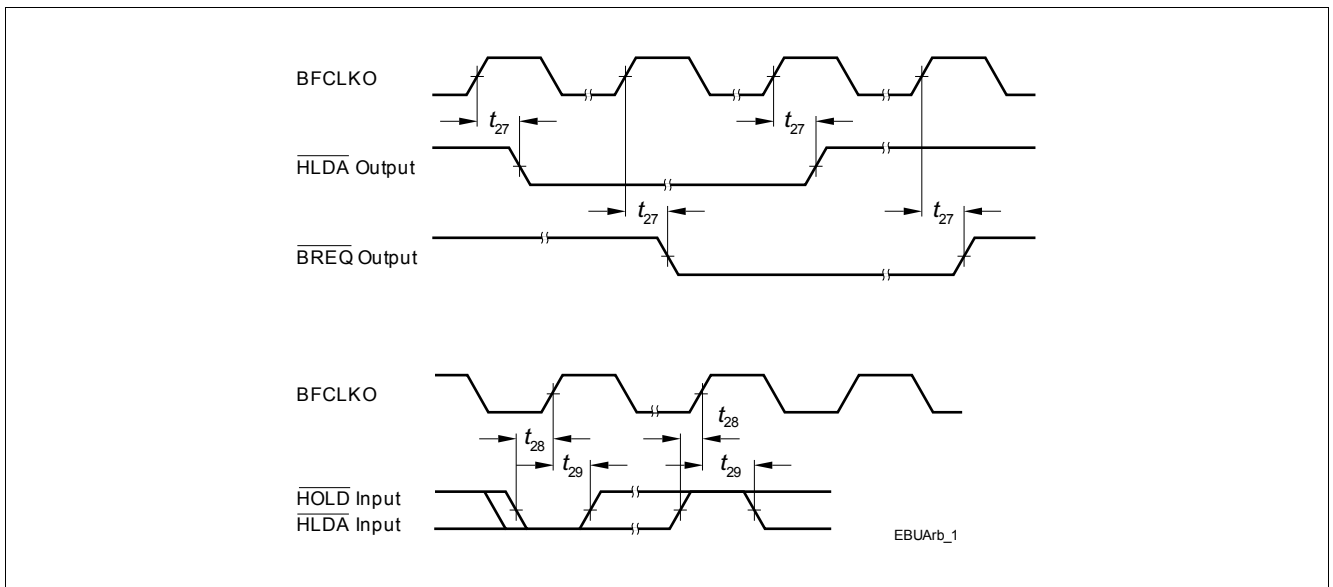

Figure 3-34 EBU Arbitration Signal Timing

3.33 CIF Parameters

CIF timings are valid only for temperatures up to the $T_J = 150^\circ\text{C}$.

Table 3-101 Timings for 5V

Parameter	Symbol	Values			Unit	Note / Test Condition
		Min.	Typ.	Max.		
Pixel clock period	t_{70} SR	10.42	-	-	ns	96 MHz
HSYNC, VSYNC set up time	t_{71} SR	2.5	-	-	ns	AL input level, hysteresis bypass
		2	-	-	ns	TTL input level, hysteresis bypass
		6.5	-	-	ns	TTL input level, hysteresis on
		4	-	-	ns	AL input level, hysteresis on
HSYNC, VSYNC hold time	t_{72} SR	2.5	-	-	ns	AL input level, hysteresis bypass
		2.5	-	-	ns	TTL input level, hysteresis bypass
		7	-	-	ns	TTL input level, hysteresis on
		4	-	-	ns	AL input level, hysteresis on
Pixel data set up time	t_{73} SR	2.5	-	-	ns	AL input level, hysteresis bypass
		2	-	-	ns	TTL input level, hysteresis bypass
		6.5	-	-	ns	TTL input level, hysteresis on
		4	-	-	ns	AL input level, hysteresis on
Pixel data hold time	t_{74} SR	2.5	-	-	ns	AL input level, hysteresis bypass
		2.5	-	-	ns	TTL input level, hysteresis bypass
		7	-	-	ns	TTL input level, hysteresis on
		4	-	-	ns	AL input level, hysteresis on

Table 3-102 Timings for 3.3V

Parameter	Symbol	Values			Unit	Note / Test Condition
		Min.	Typ.	Max.		
Pixel clock period	t_{70} SR	10.42	-	-	ns	
HSYNC, VSYNC set up time	t_{71} SR	3.5	-	-	ns	AL input level, hysteresis bypass
		4.5	-	-	ns	AL input level, hysteresis on
		9	-	-	ns	TTL input level, hysteresis on
		3	-	-	ns	TTL input level, hysteresis bypass
HSYNC, VSYNC hold time	t_{72} SR	4	-	-	ns	AL input level, hysteresis bypass
		5	-	-	ns	AL input level, hysteresis on
		10	-	-	ns	TTL input level, hysteresis on
		3.5	-	-	ns	TTL input level, hysteresis bypass
Pixel data set up time	t_{73} SR	3.5	-	-	ns	AL input level, hysteresis bypass
		4.5	-	-	ns	AL input level, hysteresis on
		9	-	-	ns	TTL input level, hysteresis on
		3	-	-	ns	TTL input level, hysteresis bypass
Pixel data hold time	t_{74} SR	4	-	-	ns	AL input level, hysteresis bypass
		5	-	-	ns	AL input level, hysteresis on
		10	-	-	ns	TTL input level, hysteresis on
		3.5	-	-	ns	TTL input level, hysteresis bypass

Table 3-103 Timings for 0.4V to 2.4V input signals (2.8V imager)

Parameter	Symbol	Values			Unit	Note / Test Condition
		Min.	Typ.	Max.		
Pixel clock period	t_{70} SR	10.42	-	-	ns	

Table 3-103 Timings for 0.4V to 2.4V input signals (2.8V imager) (cont'd)

Parameter	Symbol	Values			Unit	Note / Test Condition
		Min.	Typ.	Max.		
HSYNC, VSYNC set up time	t_{71} SR	3	-	-	ns	Hysteresis Bypass, 3.3V±10%
		9	-	-	ns	TTL Input Levels, 3.3V±10%
		4.5	-	-	ns	TTL Input Levels, 5V±10%
HSYNC, VSYNC hold time	t_{72} SR	3.5	-	-	ns	Hysteresis Bypass, 3.3V±10%
		10	-	-	ns	TTL Input Levels, 3.3V±10%
		5	-	-	ns	TTL Input Levels, 5V±10%
Pixel data set up time	t_{73} SR	3	-	-	ns	Hysteresis Bypass, 3.3V±10%
		9	-	-	ns	TTL Input Levels, 3.3V±10%
		4.5	-	-	ns	TTL Input Levels, 5V±10%
Pixel data hold time	t_{74} SR	3.5	-	-	ns	Hysteresis Bypass, 3.3V±10%
		10	-	-	ns	TTL Input Levels, 3.3V±10%
		5	-	-	ns	TTL Input Levels, 5V±10%

Table 3-104 Timings for 0.4V to 2.4V input signals (2.8V imager), ±5% pad power supply

Parameter	Symbol	Values			Unit	Note / Test Condition
		Min.	Typ.	Max.		
Pixel clock period	t_{70} SR	10.42	-	-	ns	
HSYNC, VSYNC set up time	t_{71} SR	3	-	-	ns	Hysteresis Bypass, 3.3V±5%
		9	-	-	ns	TTL Input Levels, 3.3V±5%
		4.5	-	-	ns	TTL Input Levels, 5V±5%
HSYNC, VSYNC hold time	t_{72} SR	3.5	-	-	ns	Hysteresis Bypass, 3.3V±5%
		10	-	-	ns	TTL Input Levels, 3.3V±5%
		5	-	-	ns	TTL Input Levels, 5V±5%

Electrical Specification CIF Parameters

Table 3-104 Timings for 0.4V to 2.4V input signals (2.8V imager), ±5% pad power supply (cont'd)

Parameter	Symbol	Values			Unit	Note / Test Condition
		Min.	Typ.	Max.		
Pixel data set up time	t_{73} SR	3	-	-	ns	Hysteresis Bypass, 3.3V±5%
		9	-	-	ns	TTL Input Levels, 3.3V±5%
		4.5	-	-	ns	TTL Input Levels, 5V±5%
Pixel data hold time	t_{74} SR	3.5	-	-	ns	Hysteresis Bypass, 3.3V±5%
		10	-	-	ns	TTL Input Levels, 3.3V±5%
		5	-	-	ns	TTL Input Levels, 5V±5%

Table 3-105 Timings for 1.8V imager, TTL input level

Parameter	Symbol	Values			Unit	Note / Test Condition
		Min.	Typ.	Max.		
Pixel clock period	t_{70} SR	10.42	-	-	ns	
HSYNC, VSYNC set up time	t_{71} SR	3	-	-	ns	Input signal 0.1V to 1.7V
		9	-	-	ns	Input signal 0.2V to 1.6V
		4.5	-	-	ns	Input signal 0.3V to 1.5V
		3.5	-	-	ns	Input signal 0.4V to 1.4V
HSYNC, VSYNC hold time	t_{72} SR	3.5	-	-	ns	Input signal 0.1V to 1.7V
		10	-	-	ns	Input signal 0.2V to 1.6V
		5	-	-	ns	Input signal 0.3V to 1.5V
		4	-	-	ns	Input signal 0.4V to 1.4V
Pixel data set up time	t_{73} SR	3	-	-	ns	Input signal 0.1V to 1.7V
		9	-	-	ns	Input signal 0.2V to 1.6V
		4.5	-	-	ns	Input signal 0.3V to 1.5V
		3.5	-	-	ns	Input signal 0.4V to 1.4V

Table 3-105 Timings for 1.8V imager, TTL input level (cont'd)

Parameter	Symbol	Values			Unit	Note / Test Condition
		Min.	Typ.	Max.		
Pixel data hold time	t_{74} SR	3.5	-	-	ns	Input signal 0.1V to 1.7V
		10	-	-	ns	Input signal 0.2V to 1.6V
		5	-	-	ns	Input signal 0.3V to 1.5V
		4	-	-	ns	Input signal 0.4V to 1.4V

Table 3-106 Timings for 1.8V imager, 3.3V±5% pad power supply, TTL input level

Parameter	Symbol	Values			Unit	Note / Test Condition
		Min.	Typ.	Max.		
Pixel clock period	t_{70} SR	10.42	-	-	ns	
HSYNC, VSYNC set up time	t_{71} SR	3	-	-	ns	Input signal 0.1V to 1.7V
		9	-	-	ns	Input signal 0.2V to 1.6V
		4.5	-	-	ns	Input signal 0.3V to 1.5V
		3.5	-	-	ns	Input signal 0.4V to 1.4V
HSYNC, VSYNC hold time	t_{72} SR	3.5	-	-	ns	Input signal 0.1V to 1.7V
		10	-	-	ns	Input signal 0.2V to 1.6V
		5	-	-	ns	Input signal 0.3V to 1.5V
		4	-	-	ns	Input signal 0.4V to 1.4V
Pixel data set up time	t_{73} SR	3	-	-	ns	Input signal 0.1V to 1.7V
		9	-	-	ns	Input signal 0.2V to 1.6V
		4.5	-	-	ns	Input signal 0.3V to 1.5V
		3.5	-	-	ns	Input signal 0.4V to 1.4V

Table 3-106 Timings for 1.8V imager, 3.3V±5% pad power supply, TTL input level (cont'd)

Parameter	Symbol	Values			Unit	Note / Test Condition
		Min.	Typ.	Max.		
Pixel data hold time	t_{74} SR	3.5	-	-	ns	Input signal 0.1V to 1.7V
		10	-	-	ns	Input signal 0.2V to 1.6V
		5	-	-	ns	Input signal 0.3V to 1.5V
		4	-	-	ns	Input signal 0.4V to 1.4V

3.34 Flash Target Parameters

Program Flash program and erase operation is only allowed up the $T_j = 150^\circ\text{C}$. Flash timing parameter are valid for $f_{\text{FSI}} = 100 \text{ MHz}$.

Table 3-107 FLASH

Parameter	Symbol	Values			Unit	Note / Test Condition
		Min.	Typ.	Max.		
Program Flash Erase Time per logical sector	t_{ERP} CC	-	-	1	s	cycle count < 1000
		-	$0.207 + 0.003 * (S \text{ [KByte]}) / (f_{\text{FSI}} \text{ [MHz]})^1$	-	s	cycle count < 1000, for sector of size S
Program Flash Erase Time per Multi-Sector Command	t_{MERP} CC	-	-	1	s	For consecutive logical sectors in a physical sector, cycle count < 1000
		-	$0.207 + 0.003 * (S \text{ [KByte]}) / (f_{\text{FSI}} \text{ [MHz]})^1$	-	s	For consecutive logical sector range of size S in a physical sector, cycle count < 1000
Program Flash program time per page in 5 V mode	t_{PRP5} CC	-	-	$50 + 3000 / (f_{\text{FSI}} \text{ [MHz]})$	μs	32 Byte
Program Flash program time per page in 3.3 V mode	t_{PRP3} CC	-	-	$81 + 3400 / (f_{\text{FSI}} \text{ [MHz]})$	μs	32 Byte
Program Flash program time per burst in 5 V mode	t_{PRPB5} CC	-	-	$125 + 9500 / (f_{\text{FSI}} \text{ [MHz]})$	μs	256 Byte
Program Flash program time per burst in 3.3 V mode	t_{PRPB3} CC	-	-	$410 + 12000 / (f_{\text{FSI}} \text{ [MHz]})$	μs	256 Byte
Program Flash program time for 1 MByte with burst programming in 5 V mode excluding communication	$t_{\text{PRPB5_1MB}}$ CC	-	-	0.9	s	Derived value for documentation purpose, valid for $f_{\text{FSI}} = 100\text{MHz}$
Program Flash program time for complete PFlash with burst programming in 5 V mode excluding communication	$t_{\text{PRPB5_PF}}$ CC	-	-	7.2	s	Derived value for documentation purpose, valid for $f_{\text{FSI}} = 100\text{MHz}$
Write Page Once adder	t_{ADD} CC	-	-	$15 + 500 / (f_{\text{FSI}} \text{ [MHz]})$	μs	Adder to Program Time when using Write Page Once

Electrical Specification Flash Target Parameters

Table 3-107 FLASH (cont'd)

Parameter	Symbol	Values			Unit	Note / Test Condition
		Min.	Typ.	Max.		
Program Flash suspend to read latency	t_{SPNDP} CC	-	-	$12000/(f_{FSI}^{SI} \text{ [MHz]})$	μs	For Write Burst, Verify Erased and for multi-(logical) sector erase commands
Data Flash Erase Time per Sector ²⁾	t_{ERD} CC	-	$0.12 + 0.08/(f_{FSI} \text{ [MHz]})^{1)}$	-	s	cycle count < 1000
		-	$0.57 + 0.15/(f_{FSI} \text{ [MHz]})^{1)}$	$0.928 + 0.15/(f_{FSI} \text{ [MHz]})$	s	cycle count < 125000
Data Flash Erase Time per Multi-Sector Command ²⁾	t_{MERD} CC	-	$0.12 + 0.01 * (S \text{ [KByte]}) / (f_{FSI} \text{ [MHz]})^{1)}$	-	s	For consecutive logical sector range of size S, cycle count < 1000
		-	$0.57 + 0.019 * (S \text{ [KByte]}) / (f_{FSI} \text{ [MHz]})^{1)}$	$0.928 + 0.019 * (S \text{ [KByte]}) / (f_{FSI} \text{ [MHz]})$	s	For consecutive logical sector range of size S, cycle count < 125000
Data Flash erase disturb limit	N_{DFD} CC	-	-	50	cycles	
Program time data flash per page ³⁾	t_{PRD} CC	-	-	$50 + 2500/(f_{FSI} \text{ [MHz]})^{3)}$	μs	8 Byte
Complete Device Flash Erase Time PFlash and DFlash ⁴⁾	t_{ER_Dev} CC	-	-	17	s	Derived value for documentation purpose (excl. UCBs and HSMs), valid for $f_{FSI} = 100\text{MHz}$
Data Flash program time per burst ³⁾	t_{PRDB} CC	-	-	$96 + 4400/(f_{FSI} \text{ [MHz]})^{3)}$	μs	32 Bytes
Data Flash suspend to read latency	t_{SPNDD} CC	-	-	$12000/(f_{FSI}^{SI} \text{ [MHz]})$	μs	
Wait time after margin change	$t_{FL_MarginDel}$ CC	-	-	10	μs	
Program Flash Retention Time, Sector	t_{RET} CC	20	-	-	years	Max. 1000 erase/program cycles
Data Flash Endurance per EEPROMx sector ⁵⁾	N_{E_EEP10} CC	125000	-	-	cycles	Max. data retention time 10 years
Data Flash Endurance per HSMx sector ⁵⁾	N_{E_HSM} CC	125000	-	-	cycles	Max. data retention time 10 years

Electrical Specification Flash Target Parameters
Table 3-107 FLASH (cont'd)

Parameter	Symbol	Values			Unit	Note / Test Condition
		Min.	Typ.	Max.		
UCB Retention Time	t_{RTU} CC	20	-	-	years	Max. 100 erase/program cycles per UCB, max 400 erase/program cycles in total
Data Flash access delay	t_{DF} CC	-	-	100	ns	see PMU_FCON.WSDFLASH
Data Flash ECC Delay	t_{DFECC} CC	-	-	20	ns	see PMU_FCON.WSECDF
Program Flash access delay	t_{PF} CC	-	-	30	ns	see PMU_FCON.WSPFLASH
Program Flash ECC delay	t_{PFECC} CC	-	-	10	ns	see PMU_FCON.WSECPF
Number of erase operations on DF0 over lifetime	N_{ERD0} CC	-	-	750000	cycles	
Number of erase operations on DF1 over lifetime	N_{ERD1} CC	-	-	500000	cycles	
Junction temperature limit for PFlash program/erase operations	$T_{JPFlash}$ SR	-	-	150	°C	

- 1) All typical values were characterised, but are not tested. Typical values are safe median values at room temperature
- 2) Under out-of-spec conditions (e.g. over-cycling) or in case of activation of WL oriented defects, the duration of erase processes may be increased by up to 50%.
- 3) Time is not dependent on program mode (5V or 3.3V).
- 4) Using 512 KByte erase commands.
- 5) Only valid when a robust EEPROM emulation algorithm is used. For more details see the Users Manual.

3.35 Package Outline

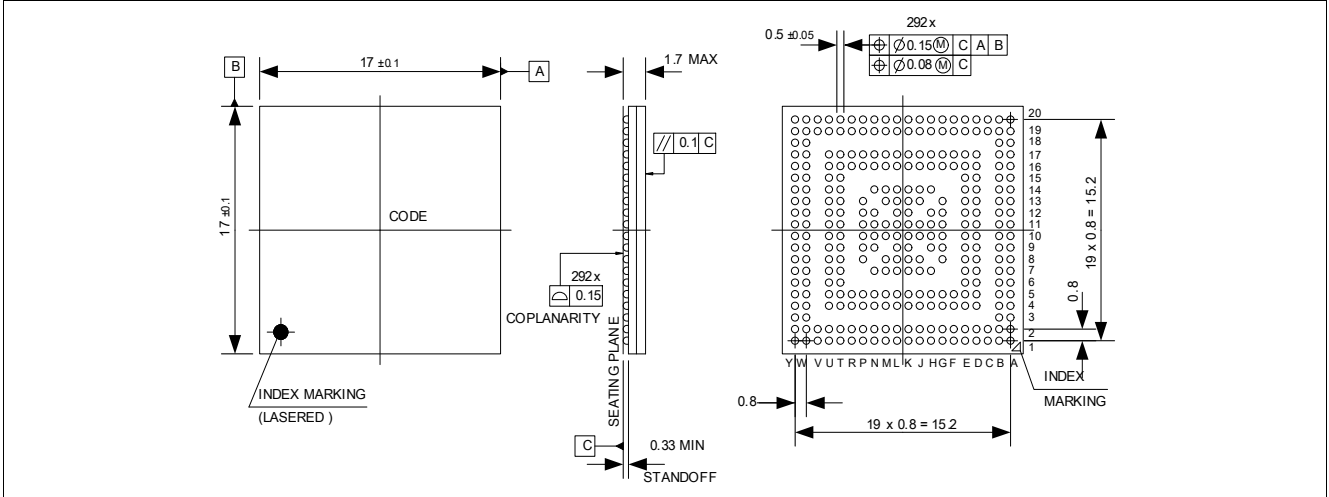

Figure 3-35 Package Outlines LF-BGA-292-6 / LF-BGA-292-10

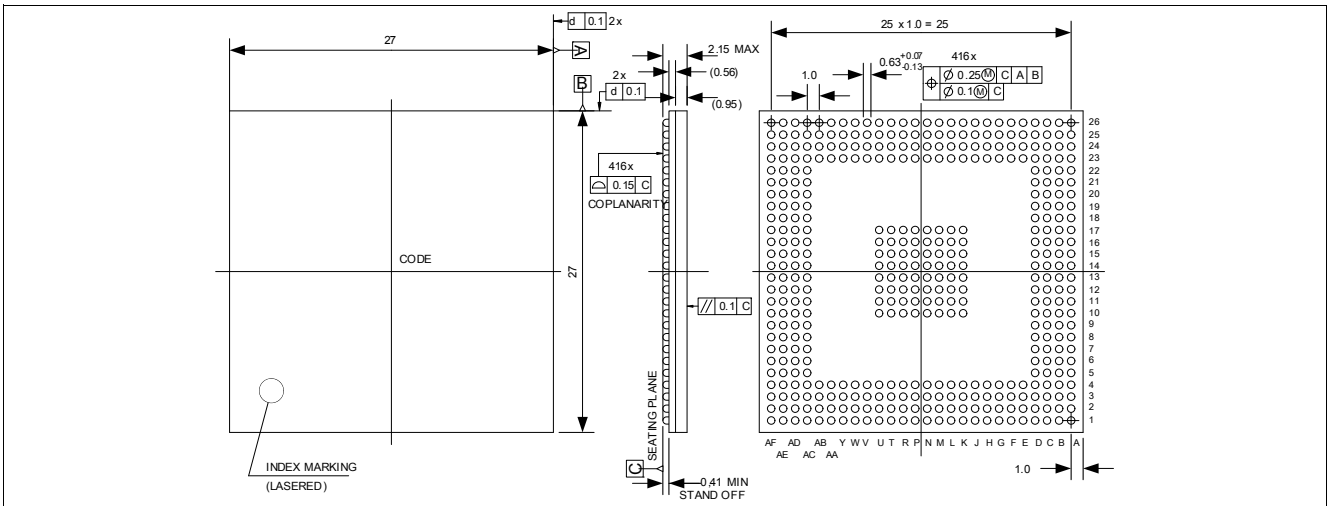

Figure 3-36 Package Outlines PG-BGA-416-26 / PG-BGA-416-29

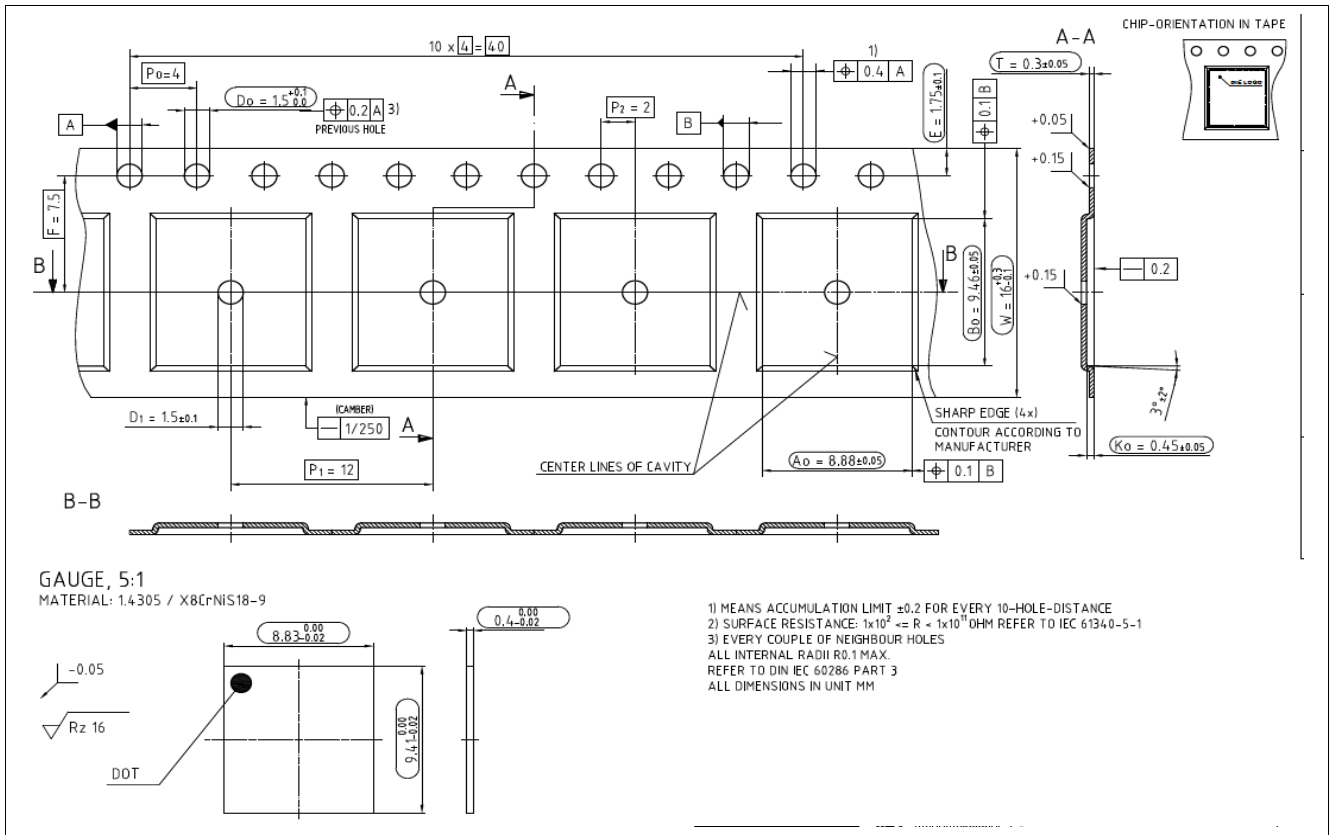

Figure 3-38 Carrier Tape Dimensions

Table 3-109 TC290 Chip Dimensions

Device	A	B	T
TC290	8,770 mm	9,357 mm	0,3 mm

3.36 Quality Declarations

Table 3-110 Quality Parameters

Parameter	Symbol	Values			Unit	Note / Test Condition
		Min.	Typ.	Max.		
Operation Lifetime	t_{OP}	-	-	24500	hour	
ESD susceptibility according to Human Body Model (HBM)	V_{HBM}	-	-	2000	V	Conforming to JESD22-A114-B
ESD susceptibility of the LVDS pins	V_{HBM1}	-	-	500	V	
ESD susceptibility according to Charged Device Model (CDM)	V_{CDM}	-	-	500	V	for all other balls/pins; conforming to JESD22-C101-C
		-	-	750	V	for corner balls/pins; conforming to JESD22-C101-C
Moisture Sensitivity Level	MSL	-	-	3		Conforming to Jedec J-STD--020C for 240C

4 History

4.1 Changes from TC29xBB_v1.1 to TC29xBC_v1.0

- VADC
 - Add parameter t_{WU}
 - Add parameter R_{MDU}
 - Add parameter R_{MDD}
- Changes in table 'Class LP 3.3V' of Standard_Pads
 - Change note of V_{ILHLP} from 'Hysteresis inactive; not available for P14.2, P14.4, and P15.1' to 'Hysteresis inactive; not available for P14.2, P14.4, P15.1, P15.10 and P15.11'
- Changes in table 'Class LP 5V' of Standard_Pads
 - Change note of V_{ILHLP} from 'Hysteresis inactive; not available for P14.2, P14.4, and P15.1' to 'Hysteresis inactive; not available for P14.2, P14.4, P15.1, P15.10 and P15.11'
- ERAY
 - Add statement 'The timings of this section are valid for the strong driver and either sharp edge settings of the output drivers with $C_L = 25$ pF. For the inputs the hysteresis has to be configured to inactive.'
- Package Outline
 - change values in table 'TC290 Chip Dimenions'

4.2 Changes from v1.0 to v1.1

- add package type version PG-LFBGA-516-10
- add package type version PG-BGA-416-29
- add package type version LF-BGA-292-10

www.infineon.com

Published by Infineon Technologies AG

Looking for pricing, stock, or lifecycle information?

Click below to explore more details on WIN SOURCE:

- ⊖ [View TC297TP128F300NBCKXUMA1 on WIN SOURCE](#)
- ⊖ [Infineon Technologies Information](#)

Optimize Your Supply Chain with WIN SOURCE Solutions

- ✓ Global Sourcing Solution
- ✓ Obsolete Management
- ✓ Cost Control Management
- ✓ Shortage Management
- ✓ Alternative Solution
- ✓ Excess Inventory Management