



THE DATASHEET OF ECS40AC



DCSA SERIES

Current Transducers



Wiring Diagram

CONNECTION FOR 4 - 20 MA LOOP

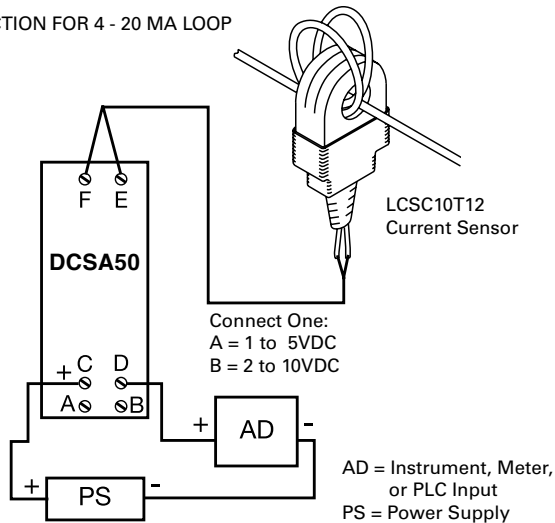

Description

The DCSA Series is a loop-powered, linear output current transducer that provides an output that is directly proportional to the RMS AC current passing through the LCSC10T12 sensor. The DCSA Series provides either an analog current or voltage: 4-20 mA, 1 to 5VDC, or 2 to 10VDC. Each unit is factory calibrated for monitoring (with the LCSC10T12 connected) in one of four ranges; 0-5, 0-10, 0-20, or 0-50A. Zero and span adjustments allow field calibration if needed. The DCSA Series mounts on both DIN 1 and DIN 3 rails.

Operation

The DCSA Series varies the effective resistance of its output in direct proportion to the current flowing in the conductor monitored by the LCSC10T12. Connecting the power supply to terminals C & D provides a 4 to 20mA DC current. Connect the power supply to terminals C & A to get 1 to 5VDC at terminal D. Connect the power supply to terminals C & B to get 2 to 10VDC at terminal D.

Features

- Mounts on DIN 1 or DIN 3 rail
- 0-50A in 4 ranges using LCSC10T12 sensor
- Loop powered from 10 to 30VDC
- Linear output from 4-20mA, 1-10VDC
- Zero & span adjustments
- Separate sensor & control unit

Accessories



LCSC10T12 Toroidal Current Sensor

Remote monitoring of currents up to 50A.

To LCSC10T12 Current Sensor

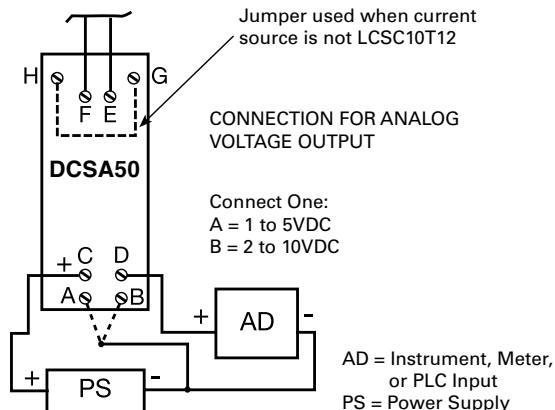

Ordering Information

MODEL	CURRENT RANGE WITH LCSC10T12	INPUT RANGE (F TO E)
DCSA5	0-5A	0-5mA AC
DCSA20	0-20A	0-20mA AC
DCSA50	0-50A	0-50mA AC

If you don't find the part you need, call us for a custom product 800-843-8848

DCSA SERIES

Specifications

Input

Ranges (without LCSC10T12 connected)	0 - 5mA, 0 - 10mA, 0 - 20mA, or 0 - 50mA AC
4 factory calibrated ranges in mA AC	0 - 5mA, 0 - 10mA, 0 - 20mA, or 0 - 50mA AC
Factory calibration	±0.5% of full scale
Repeat Accuracy	±0.25% of full scale under fixed conditions
Response Time	≈ 300ms
Temperature Coefficient	±0.05%/°C
Input to Output	Not isolated

Output

Type	Current directly proportional to input current
Analog Range	4 - 20mA, or 1 to 5VDC or 2 to 10VDC
Supply Voltage*	10 to 30VDC
Momentary Voltage	40VDC for 1m
Zero Adjust	≈ 3.75 - 4.25mA
Span Adjust	18mA - 22mA
Adjustment	Mini-screw, multi-turn potentiometer

Protection

Dielectric Breakdown	≥ 2500V RMS terminals to mounting surface
Insulation Resistance	≥ 100 MΩ
Polarity	Units are reverse polarity protected

Mechanical

Mounting	DIN 1 & DIN 3 rail mounting
Termination	
Wire clamp	For 22 - 14AWG (.336 mm ² ... 2.5 mm ²)

Environmental

Operating/Storage Temperature	-30° to 60°C / -40° to 85°C
Humidity	95% relative, non-condensing
Weight	≈ 1.6 oz (45.4 g)

Accessory - LCSC10T12 Toroidal Sensor

Number of Turns	1000
Nominal Output Current	
Full Range	0 - 50 mA
Maximum Allowable Current	Steady 50A turns; Inrush 300A turns for 10s
Burden	≤ 0.5 VA
Frequency	
0 - 20A / 21 - 50A	20/100 Hz / 30/100 Hz
Sensor Hole	0.36 in. (9.14 mm) for up to #4 AWG (21.1 mm ²) THHN wire
Weight	≈ 1 oz (28.3 g)

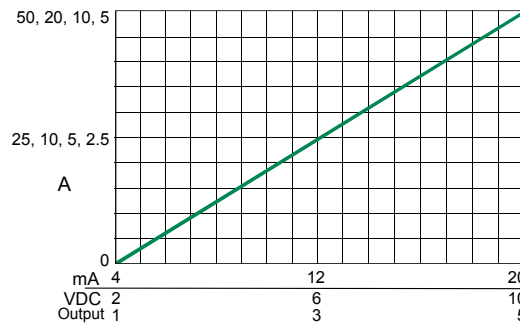

*Minimum loop-power supply voltage equals the minimum sensor voltage 10VDC plus the voltage drop developed across all the other loop devices at 20mA.

Monitored Current Amps Diagram



Looking for pricing, stock, or lifecycle information?

Click below to explore more details on WIN SOURCE:

-  [View ECS40AC on WIN SOURCE](#)
-  [Littelfuse Inc. Information](#)

Optimize Your Supply Chain with WIN SOURCE Solutions

-  Global Sourcing Solution
-  Obsolete Management
-  Cost Control Management
-  Shortage Management
-  Alternative Solution
-  Excess Inventory Management