



THE DATASHEET OF RI-UHF-STRAP-08



UHF Gen2 STRAP

FEATURES

- Meets EPCGlobal™ Gen2 (v. 1.0.9) and ISO/IEC 18000-6C
- 860 ~ 960 MHz Global Operating Frequency
- Supports Optional Gen2 Commands: Block Write and Block Erase
- 192-bit memory: 96-bit Electronic Product Code (EPC™), 32-bit Access Password, 32-bit KILL Password, 32-bit TID memory (Factory Programmed and Locked)
- Designed for High-performance, Low Power Consumption based on most Advanced Silicon Process Node for RFID (130 nm)
- Fast tag Singulation using most Advanced Anti-Collision Scheme
- Suitable for H-field and E-field operation
- RoHS Compliant

APPLICATIONS

- Supply Chain Management & Distribution Logistics
- Express Parcel Delivery
- Airline Baggage Handling
- Asset Tagging

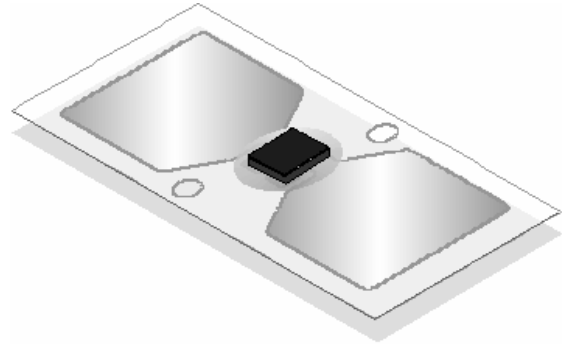
DESCRIPTION

Large retailers have issued mandates to their suppliers to ship cases and pallets of goods/products with RFID Smart Labels attached. TI's Gen2 Straps are intended to simplify the manufacture of inlays for conversion into Smart Labels for various applications. The Straps are based on the EPCGlobal™ Gen2 specification (v. 1.0.9) and ISO/IEC 18000-6C

TI's Gen2 Straps operate with extremely low power and yet provide long read and write ranges, fast data transfer and high Smart Label throughput.

A detailed description of the command set, memory and operation of the Strap is given in the *UHF Gen2 Protocol reference Guide* (literature number 11-09-21-700)

ORDERING INFORMATION

Texas Instruments' UHF Gen2 Strap is available as listed in Table 1:

PART NUMBER	DESCRIPTION
RI-UHF-STRAP-08	EPCGlobal™ UHF Gen2 Strap

Table 1: Part Number

Please be aware that an important notice concerning availability, standard warranty, and use in critical applications of Texas Instruments semiconductor products and disclaimers thereto appear at the end of this data sheet.

ELECTRICAL SPECIFICATIONS

ABSOLUTE MAXIMUM RATINGS ⁽¹⁾

PARAMETER	NOTES	MIN.	MAX.	UNITS
Input Current, pad to pad			1	mA
Input voltage to any pad (sustained)			1.5	V
Power dissipation	Ta = 25°C		1.5	mW
Storage Temperature	Single Strap	-40	+85	°C
	On Reel	-40	+45	°C
Operating temperature	Read	-40	+65	°C
	Write	-25	+65	
Assembly Survival Temperature	1 minute maximum		150	°C
RF Exposure	800 ~ 1000 MHz		+10	dBm
ESD Immunity	CDM	0.5		kV
	HBM	2.0		kV

(1). Stresses beyond those listed under “Absolute Maximum Ratings” may cause permanent damage to the Strap. These are the stress ratings only and functional operation of the device at these or any other condition beyond those indicated under “Recommended Operating Conditions” is not implied. Exposure to absolute maximum rated conditions for extended periods may affect the device reliability

RECOMMENDED OPERATING CONDITIONS

PARAMETER	SYMBOL	MINIMUM	MAXIMUM	UNITS
Operating Temperature	T _A	-40	65	°C
Carrier Frequency	f _{res}	860	960	MHz

ELECTRICAL CHARACTERISTICS

PARAMETER	SYMBOL	NOTE	MINIMUM	TYPICAL	MAXIMUM	UNITS
Sensitivity		Reading	-9	-13		dBm
		Programming	-6	-9		dBm
Change in Modulator Reflection Coefficient	$\Delta \Gamma$		> 0.2			
Data Retention	tDRET		10			Years
Write and Erase Endurance			100,000			Cycles
Strap Parallel Impedance ⁽²⁾		Typical Read (-13 dB)		380		Ohms
				2.8		pF

(2). The values shown have been taken with a properly designed and matched antenna attached to the strap
 For complete data on antenna matching, a “UHF Gen2 IC Antenna Reference Guide”. (11-07-21-702) is available under NDA

MECHANICAL SPECIFICATIONS

STRAP MECHANICAL SPECIFICATIONS

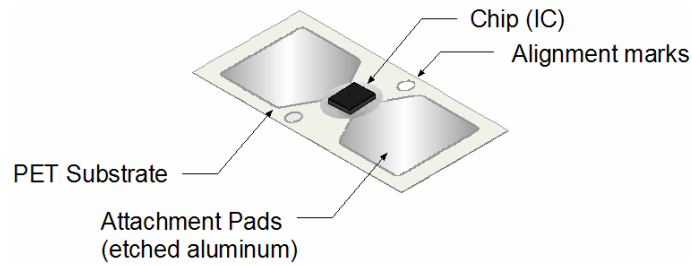

The mechanical details of each strap is shown below

PARAMETER	VALUE
Substrate thickness (PET)	50 micron (2 mil)
Die Height	150 micron (6 mil)
Aluminum layer Thickness	10 micron (0.4 mil)
Substrate Material	PET (Polyethylene Therephthalate)
Substrate Elasticity (Young's Modulus)	2~4 Gpa (290~580 kpsi)
Coefficient of Thermal Expansion (CTE)	$20\sim 80 \times 10^{-6} \text{ } ^\circ\text{C}^{-1}$
Strap Web Width	9.00 mm ± 0.1 [0.35 inch ± 0.004]
Strap Pitch	4.00 mm $\begin{matrix} +0.10 \\ -0.40 \end{matrix}$ [0.16 in $\begin{matrix} +0.004 \\ -0.016 \end{matrix}$]

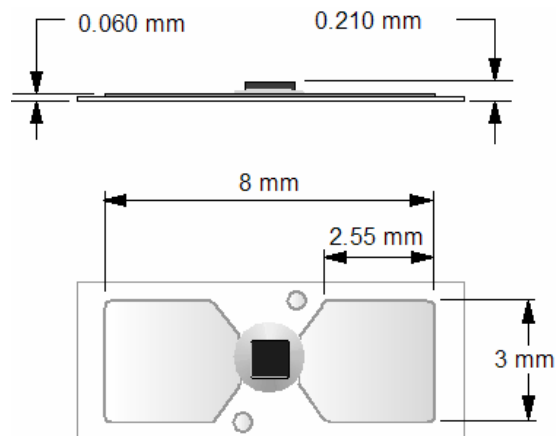

STRAP DELIVERY AND FURTHER HANDLING

STRAP DELIVERY

Straps are delivered on reels of 40,000 units. The reel details are shown below

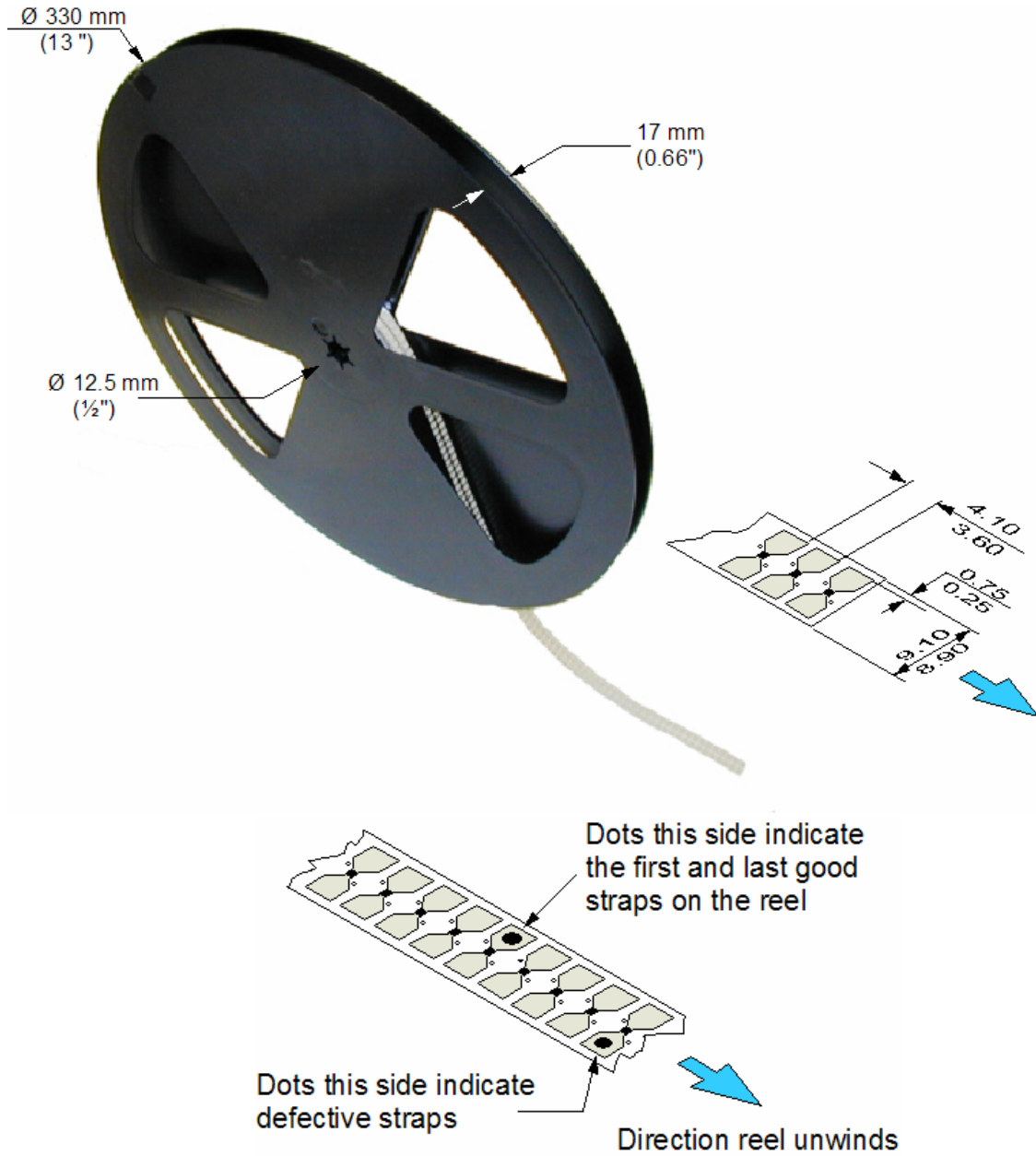

LEADER /TAIL

Each reel has 1 m (39") of chip-less Straps at the start (leader) and end (tail) of each reel. This allows the reel to be loaded onto a conversion machine without any loss of good product. The first and last good Straps are marked with ink dots as shown above.

DEFECTIVE STRAPS

Each Strap is 100% tested on the production line and any Strap found to be defective is ink marked as shown previously. For each defective Strap found, an additional Strap is added at the end of the good Straps on the reel.

SHEAR FORCE LIMITS

When handling the Straps, the shear force must not exceed 6 N

Shear Force	6 N (1.35 lbf)
-------------	----------------

CHIP AREA PRESSURE

During the Strap conversion process, the pressure on the chip must not exceed 10 N/mm².

Pressure (per unit die area)	10 N/mm (1450 psi)
------------------------------	--------------------

WARNING

EXCESSIVE PRESSURE ON THE CHIP AREA WILL RESULT IN THE CHIP/SUBSTRATE CONDUCTOR CRACKING AND AN EXCESSIVE SHEAR FORCE COULD CAUSE THE CHIP TO SEPARATE FROM THE STRAP

TAPE TENSION AND BENDING

Three conditions exist and these are shown in the drawing below. Exceeding these limits will result in damage to the Straps.

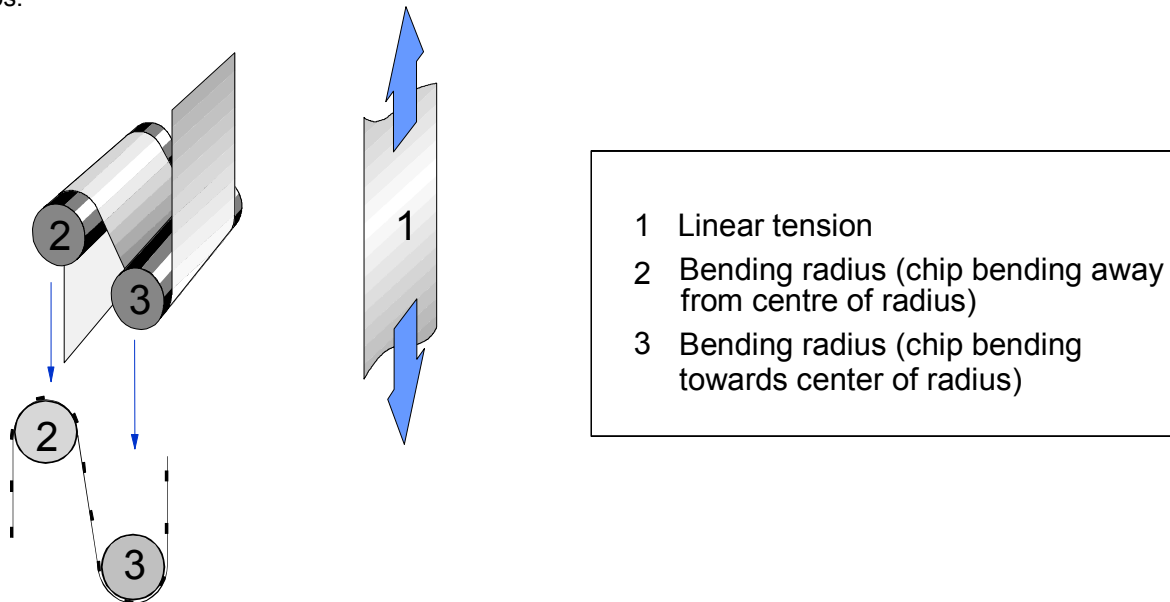

The recommended limits for these conditions are shown in the following table

CONDITION		LIMIT
1	Maximum Linear Tension	6 N (1.35 lbf)
2	Minimum Bending Radius (away from center)	15 mm (0.6")
3	Minimum Bending Radius (towards the center)	15 mm (0.6")

ESD PRECAUTIONS

During winding and un-winding operations, the Strap tape can become electrostatically charged. The high current density of the electrostatic discharge (ESD) can severely damage the Straps' chips. The amount of ESD very much depends on the winding speed and tension. We strongly advise that de-ionization equipment is installed at all wind/ un-wind points.

PARAMETER	VALUE
ESD Immunity	2.0 kV (Class 2 Human Body Model)
De-ionizer Setting	2 KeV HM

STORAGE CONDITIONS

Reels should be kept in the original packaging during storage.

ANTENNA DESIGN, POSITIONING AND BONDING

ANTENNA DESIGN

Texas Instruments can help you with a suitable antenna based on a reference design or assist you in a custom design⁽³⁾.

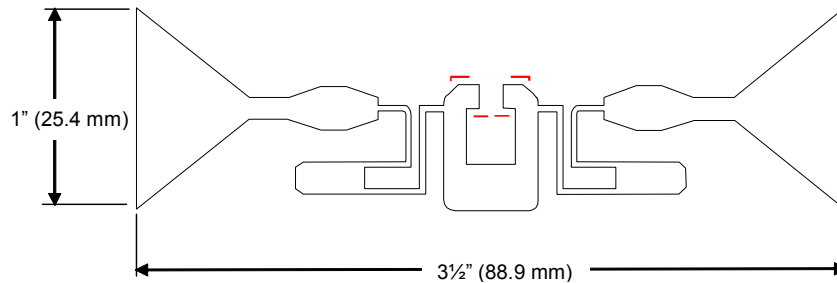

Reference Antenna Design

(3). Antenna design is beyond the scope of this document. Further information on antenna design is given in document *UHF Gen2 IC Antenna Design Reference Guide* (11-07-21-702) which is available under NDA..

PLACEMENT TOLERANCES

Texas Instruments' reference antenna is intended for a 75 micron PET substrate and has placement markings to ensure correct Strap alignment and to aid inspection and qualification. The pads of the Straps must fall within the tolerance marks outlined on the antenna to determine the correct positioning:

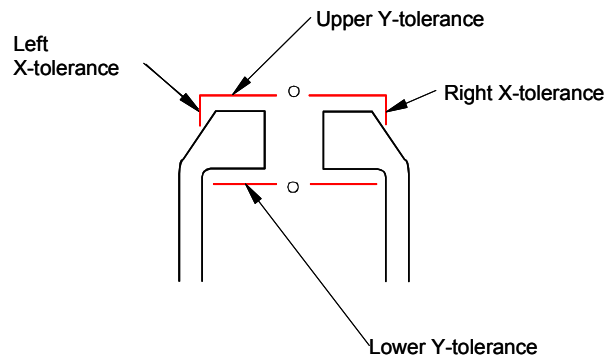

The drawings below show Straps, whose placement is within tolerance

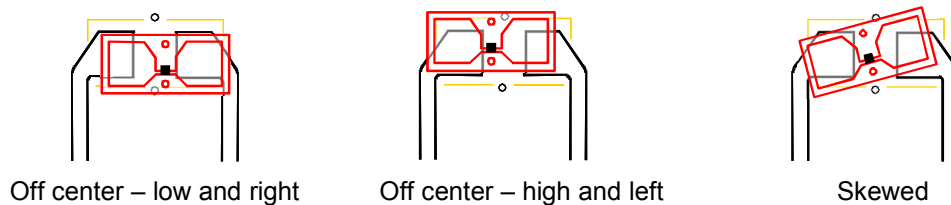

The drawings below show Straps with out-of-tolerance placements

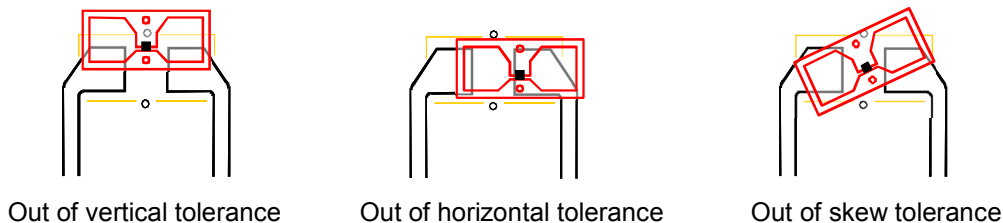

NON-TEXAS INSTRUMENTS DESIGN

When attaching Straps to non-TI antennas, it is important that 50% of each bonding pad is in contact with the antenna.. The bonding area is shown below.

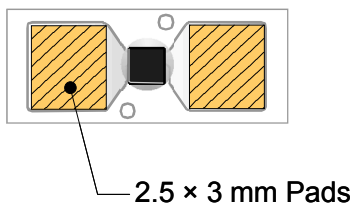

ANTENNA SUBSTRATE MATERIALS

With Straps, the creation of inlays is made much easier. Antennas can be produced on a variety of substrate materials including direct printing, using conductive inks onto non-conductive materials such as paper, cartons and thin film polymers. Texas Instruments uses PET (Polyethylene Terephthalate) as a substrate. This material is stable, clear, can be printed and has a melting point close to 250 °C (480 °F)

CREATING THE ANTENNA

The antenna tracks (traces) can be formed in a number of ways. These include:

- Printing using conductive inks. E.g. Silver
- Etched copper on polymer film
- Etched aluminum on polymer film

STRAP BONDING

Bonding of the strap to the antenna can be done using a variety of methods. The techniques include:

- Anisotropic Conductive Film
- Heat curing epoxy
- UV curing epoxy
- Ultrasonic welding

Customers should contact the supplier or manufacturer of your strap attachment equipment for advice on creating the antenna and the recommended attachment technique and bonding adhesive.

IMPORTANT NOTICE

Texas Instruments Incorporated and its subsidiaries (TI) reserve the right to make corrections, modifications, enhancements, improvements, and other changes to its products and services at any time and to discontinue any product or service without notice. Customers should obtain the latest relevant information before placing orders and should verify that such information is current and complete. All products are sold subject to TI's terms and conditions of sale supplied at the time of order acknowledgment.

TI warrants performance of its hardware products to the specifications applicable at the time of sale in accordance with TI's standard warranty. Testing and other quality control techniques are used to the extent TI deems necessary to support this warranty. Except where mandated by government requirements, testing of all parameters of each product is not necessarily performed.

TI assumes no liability for applications assistance or customer product design. Customers are responsible for their products and applications using TI components. To minimize the risks associated with customer products and applications, customers should provide adequate design and operating safeguards.

TI does not warrant or represent that any license, either express or implied, is granted under any TI patent right, copyright, mask work right, or other TI intellectual property right relating to any combination, machine, or process in which TI products or services are used. Information published by TI regarding third-party products or services does not constitute a license from TI to use such products or services or a warranty or endorsement thereof. Use of such information may require a license from a third party under the patents or other intellectual property of the third party, or a license from TI under the patents or other intellectual property of TI.

Reproduction of information in TI data books or data sheets is permissible only if reproduction is without alteration and is accompanied by all associated warranties, conditions, limitations, and notices. Reproduction of this information with alteration is an unfair and deceptive business practice. TI is not responsible or liable for such altered documentation.

Resale of TI products or services with statements different from or beyond the parameters stated by TI for that product or service voids all express and any implied warranties for the associated TI product or service and is an unfair and deceptive business practice. TI is not responsible or liable for any such statements.

Following are URLs where you can obtain information on other Texas Instruments products and application solutions:

Products

Amplifiers	amplifier.ti.com
Data Converters	dataconverter.ti.com
DSP	dsp.ti.com
Interface	interface.ti.com
Logic	logic.ti.com
Power Mgmt	power.ti.com
Microcontrollers	microcontroller.ti.com

Applications

Audio	www.ti.com/audio
Automotive	www.ti.com/automotive
Broadband	www.ti.com/broadband
Digital Control	www.ti.com/digitalcontrol
Military	www.ti.com/military
Optical Networking	www.ti.com/opticalnetwork
Security	www.ti.com/security
Telephony	www.ti.com/telephony
Video & Imaging	www.ti.com/video
Wireless	www.ti.com/wireless

Mailing Address: Texas Instruments
Post Office Box 655303 Dallas, Texas 75265

Copyright © 2006, Texas Instruments Incorporated

Looking for pricing, stock, or lifecycle information?

Click below to explore more details on WIN SOURCE:

-  [View RI-UHF-STRAP-08](#) on WIN SOURCE
-  [Texas Instruments](#) Information

Optimize Your Supply Chain with WIN SOURCE Solutions

-  Global Sourcing Solution
-  Obsolete Management
-  Cost Control Management
-  Shortage Management
-  Alternative Solution
-  Excess Inventory Management