



**THE DATASHEET OF  
CRS0603-16W-474JT**





## FEATURES:

- Confirmed test data with no failures up to 9,000 hours
- TCR as low as  $\pm 100\text{ppm}$
- Moisture Sensitivity Level: 1
- Specially designed termination prevents an open mode due to the formation of Silver Sulfide ( $\text{Ag}_2\text{S}$ )



## PART NUMBER STRUCTURE

CRS Series	1206 Size	4W Power Rating	103 Resistance Code	J Tolerance	T Packaging
0201	20W = 0.05W	3 DIGIT (J TOL.)	e.g. 2R2=2.2 $\Omega$ 103=10K $\Omega$	D = $\pm 0.5\%$ F = $\pm 1\%$ J = $\pm 5\%$	T = Tape & Reel
0402	16W = 0.063W				
0603	10W = 0.10W	4 DIGIT (F TOL.)	e.g. 10R2=10.2 $\Omega$ 1002=10K $\Omega$		
0805	8W = 0.125W				
1206	4W = 0.25W				
1210	2W = 0.50W				
2010	W = 0.75W				
2512	X = 1.0W				

**Example P/N:** CRS1206-4W-103JT

Standard termination finish is 100% matte Tin (Sn) over Nickel.

## DIMENSIONS

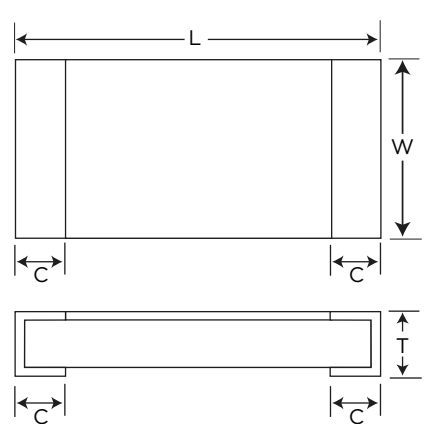

Unit: inches (mm)

Size (inches)	L	W	T	C
0201	0.024 $\pm$ 0.002 (0.6 $\pm$ 0.05)	0.012 $\pm$ 0.001 (0.3 $\pm$ 0.02)	0.010 $\pm$ 0.002 (0.25 $\pm$ 0.05)	0.006 $\pm$ 0.002 (0.15 $\pm$ 0.05)
0402	0.040 $\pm$ 0.002 (1.0 $\pm$ 0.05)	0.020 $\pm$ 0.002 (0.5 $\pm$ 0.05)	0.014 $\pm$ 0.002 (0.35 $\pm$ 0.05)	0.008 $\pm$ 0.004 (0.2 $\pm$ 0.01)
0603	0.063 $\pm$ 0.008 (1.6 $\pm$ 0.2)	0.031 $\pm$ 0.008 (0.8 $\pm$ 0.2)	0.014 $\pm$ 0.004 (0.45 $\pm$ 0.10)	0.010 $\pm$ 0.006 (0.25 $\pm$ 0.15)
0805	0.079 $\pm$ 0.008 (2.0 $\pm$ 0.2)	0.050 $\pm$ 0.008 (1.25 $\pm$ 0.20)	0.018 $\pm$ 0.006 (0.45 $\pm$ 0.15)	0.016 $\pm$ 0.008 (0.4 $\pm$ 0.20)
1206	0.126 $\pm$ 0.008 (3.2 $\pm$ 0.2)	0.063 $\pm$ 0.008 (1.6 $\pm$ 0.2)	0.022 $\pm$ 0.006 (0.57 $\pm$ 0.15)	0.018 $\pm$ 0.008 (0.45 $\pm$ 0.2)
1210	0.126 $\pm$ 0.008 (3.2 $\pm$ 0.2)	0.098 $\pm$ 0.006 (2.50 $\pm$ 0.15)	0.022 $\pm$ 0.006 (0.56 $\pm$ 0.15)	0.018 $\pm$ 0.008 (0.45 $\pm$ 0.20)
2010	0.197 $\pm$ 0.006 (5.0 $\pm$ 0.15)	0.098 $\pm$ 0.006 (2.50 $\pm$ 0.15)	0.022 $\pm$ 0.005 (0.55 $\pm$ 0.12)	0.024 $\pm$ 0.01 (0.60 $\pm$ 0.25)
2512	0.248 $\pm$ 0.006 (6.3 $\pm$ 0.15)	0.122 $\pm$ 0.006 (3.1 $\pm$ 0.15)	0.022 $\pm$ 0.005 (0.55 $\pm$ 0.12)	0.024 $\pm$ 0.01 (0.60 $\pm$ 0.25)

## STRUCTURE

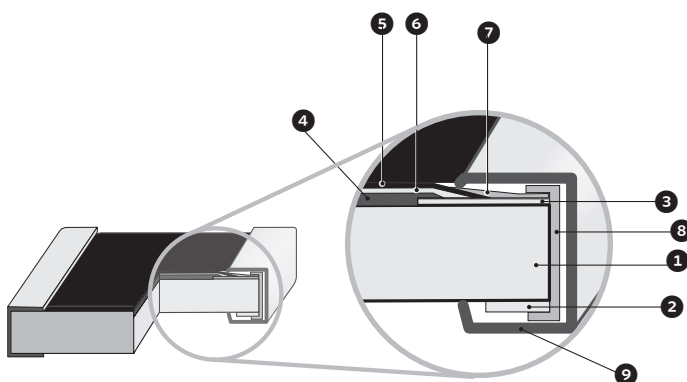

1	Alumina Substrate	6	Protective Overcoat II
2	Bottom Electrode (Ag)	7	Side Electrode (resin Ag)
3	Topside Electrode (Ag-Pd)	8	Internal Electrode (Ni)
4	Resistance Element (RuO <sub>2</sub> )	9	External Electrode (Sn)
5	Protective Overcoat I		

### ELECTRICAL SPECIFICATION & RANGE

SIZE	0201	0402	0603	0805	1206	1210	2010	2512
Power Rating at 70°C (W)	0.05W (1/20W)	0.063W (1/16W)	0.10W (1/10W)	0.125W (1/8W)	0.25W (1/4W)	0.33W (1/3W)	0.75W (3/4W)	1.0W (1W)
Zero ohm (Jumper) Current Rating	1A	1A	1A	2A	2A	2.5A	3.5A	4A
Zero ohm (Jumper) Resistance	50 mΩ (max)	50 mΩ (max)	50 mΩ (max)	50 mΩ (max)	50 mΩ (max)	50 mΩ (max)	50 mΩ (max)	50 mΩ (max)
Max. Working Voltage	√-PR or 25V whichever is less	√-PR or 50V whichever is less	√-PR or 50V whichever is less	√-PR or 150V whichever is less	√-PR or 200V whichever is less	√-PR or 200V whichever is less	√-PR or 200V whichever is less	√-PR or 250V whichever is less
Operating Temp. Range	-55°C to +125°C	-55°C to +155°C	-55°C to +155°C	-55°C to +155°C	-55°C to +155°C	-55°C to +155°C	-55°C to +155°C	-55°C to +155°C
Tolerance	TCR	Resistance Range	Resistance Range	Resistance Range	Resistance Range	Resistance Range	Resistance Range	Resistance Range
±0.5% (D)	±100ppm	-	10Ω - 1MΩ	10Ω - 1MΩ	10Ω - 1MΩ	10Ω - 1MΩ	10Ω - 1MΩ	10Ω - 1MΩ
	±200ppm	-	0Ω, 1Ω - 9.76Ω, 1.02M - 10MΩ	0Ω, 1Ω - 9.76Ω, 1.02M - 10MΩ	0Ω, 1Ω - 9.76Ω, 1.02M - 10MΩ	0Ω, 1Ω - 9.76Ω, 1.02M - 10MΩ	0Ω, 1Ω - 9.76Ω, 1.02M - 10MΩ	0Ω, 1Ω - 9.76Ω, 1.02M - 10MΩ
±1% (F)	±100ppm	-	10Ω - 1MΩ	10Ω - 1MΩ	10Ω - 1MΩ	10Ω - 1MΩ	10Ω - 1MΩ	10Ω - 1MΩ
	±200ppm	1Ω - 10MΩ	0Ω, 1Ω - 9.76Ω, 1.02M - 10MΩ	0Ω, 1Ω - 9.76Ω, 1.02M - 10MΩ	0Ω, 1Ω - 9.76Ω, 1.02M - 10MΩ	0Ω, 1Ω - 9.76Ω, 1.02M - 10MΩ	0Ω, 1Ω - 9.76Ω, 1.02M - 10MΩ	0Ω, 1Ω - 9.76Ω, 1.02M - 10MΩ
±5% (J)	±100ppm	-	10Ω - 1MΩ	10Ω - 1MΩ	10Ω - 1MΩ	10Ω - 1MΩ	10Ω - 1MΩ	10Ω - 1MΩ
	±200ppm	1Ω - 10MΩ	0Ω, 1Ω - 9.76Ω, 1.02M - 10MΩ	0Ω, 1Ω - 9.76Ω, 1.02M - 10MΩ	0Ω, 1Ω - 9.76Ω, 1.02M - 10MΩ	0Ω, 1Ω - 9.76Ω, 1.02M - 10MΩ	0Ω, 1Ω - 9.76Ω, 1.02M - 10MΩ	0Ω, 1Ω - 9.76Ω, 1.02M - 10MΩ

NOTES: (1) Overload Voltage = 2.5\*V(P\**R*). (2) Zero Ohm Jumper is <50mΩ

### MARKING CODE

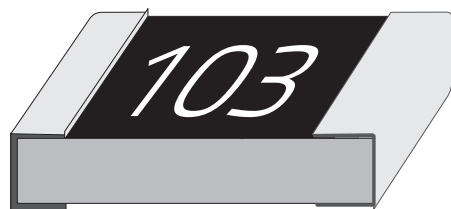

- 1% E-24 values for 0603 size and larger are typically marked with the standard 3 digit marking code.
  - 1% E-96 values for 0805 size and larger, will be marked with standard 4 digit marking code.
  - 5% E-24 values for 0603 size and larger, will be marked with standard 3 digit marking code.
  - 0603 - 1% E-96 values will be marked with a standard 3 digit alpha numeric code (Please see alpha numeric marking codes for resistors).
- Note:** 0201 and 0402 sizes cannot be marked.

### ANTI-SULFURATION TEST DATA

#### TEST CONDITIONS:

Resistors are mounted on the test board with the power "ON" and kept in the atmosphere of 50°C, Relative Humidity of 95% and H2S - 3PPM is present in the atmosphere.

10 pieces each of regular resistors and anti-sulfuration resistors were tested.

HOURS	1,000	2,000	3,000	4,000	4,500	5,000	5,500	6,000	6,500	7,000	8,000	8,500	9,000
Standard Thick Film resistors	o	o	o	o	X1	X2	X1	X1	X3	X1	X1	-	-
Anti-sulfuration resistors	o	o	o	o	o	o	o	o	o	o	o	o	o

o = No failure. X1 = 1 failure. X2 = 2 failures. X3 = 3 failures.

#### TEST RESULTS:

Standard Thick Film Resistors start failing (open) from 4,500 hours and by 8,500 hours, all have failed (opened). Anti-sulfuration resistors have no failures up to 9,000 hours.

**TAPE & REEL SPECIFICATIONS**

**TAPE**

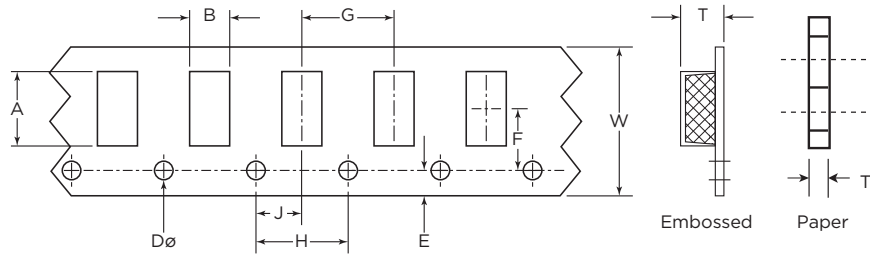

Unit: mm

TAPE	SIZE	A	B	W	E	F	T	G	H	J	DØ
Paper	0201	0.7 ± 0.08	0.4 ± 0.08	8.0 ± 0.2	1.75 ± 0.1	3.5 ± 0.05	0.42 ± 0.2	2.0 ± 0.05	4.0 ± 0.1	2.0 ± 0.05	1.5 + 0.1-0
	0402	1.15 ± 0.1	0.65 ± 0.1	8.0 ± 0.2	1.75 ± 0.1	3.5 ± 0.05	0.45 ± 0.1	2.0 ± 0.05	4.0 ± 0.1	2.0 ± 0.05	1.5 + 0.1-0
	0603	1.9 ± 0.1	1.1 ± 0.1	8.0 ± 0.2	1.75 ± 0.1	3.5 ± 0.05	0.70 ± 0.1	4.0 ± 0.1	4.0 ± 0.1	2.0 ± 0.05	1.5 + 0.1-0
	0805	2.4 ± 0.1	1.65 ± 0.1	8.0 ± 0.2	1.75 ± 0.1	3.5 ± 0.05	0.85 ± 0.1	4.0 ± 0.1	4.0 ± 0.1	2.0 ± 0.05	1.5 + 0.1-0
	1206	3.5 ± 0.1	1.9 ± 0.1	8.0 ± 0.2	1.75 ± 0.1	3.5 ± 0.05	0.85 ± 0.1	4.0 ± 0.1	4.0 ± 0.1	2.0 ± 0.05	1.5 + 0.1-0
	1210	3.5 ± 0.1	2.8 ± 0.1	8.0 ± 0.2	1.75 ± 0.1	3.5 ± 0.05	0.85 ± 0.1	4.0 ± 0.1	4.0 ± 0.1	2.0 ± 0.05	1.5 + 0.1-0
Embossed	2010	5.5 ± 0.2	2.8 ± 0.2	12.0 ± 0.3	1.75 ± 0.1	5.5 ± 0.05	1.2	4.0 ± 0.1	4.0 ± 0.1	2.0 ± 0.05	1.5 + 0.1-0
	2512	6.7 ± 0.2	3.5 ± 0.2	12.0 ± 0.3	1.75 ± 0.1	5.5 ± 0.05	1.2	8.0 ± 0.1	4.0 ± 0.1	2.0 ± 0.05	1.5 + 0.1-0

**REEL**

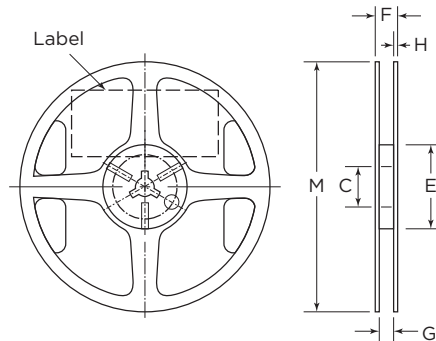

C	E	F	G	H	M
13.0 ± 0.2 (0.51 ± 0.008)	60.0 ± 1.0 (2.36 ± 0.03)	11.4 ± 1.0 (0.45 ± 0.04)	9.0 ± .3 (0.35 ± 0.012)	1.5 ± .3 (0.06 ± 0.012)	Unit: mm (inch) 180 ± 2.0 (7.09 ± 0.08)

Minimum of 30 empty pockets at the beginning of reel, 65 minimum empty pockets at the end.

**PEEL BACK FORCE AND DIRECTION DIAGRAM**

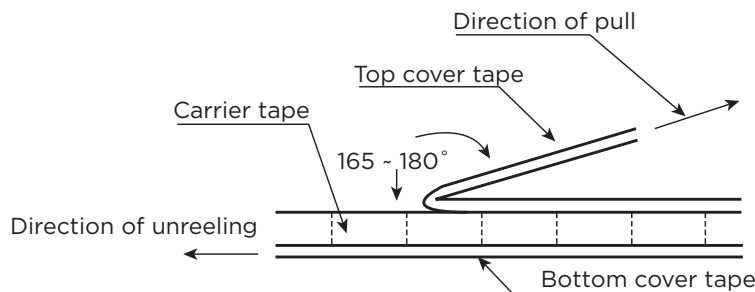

Peel back force and direction of peel back angle should follow EIA481-1-A. Peel back force should be between 0.1N - 1.3N and peel back angle of 165° - 180°.

### ENVIRONMENTAL CHARACTERISTICS



TEST	REQUIREMENT			TEST METHOD
	±1% and below	±5%	Jumper	
Temperature Coefficient of Resistance (T.C.R.)	As Spec.			JIS-C-5201-1 4.8 IEC-60115-1 4.8 At 25°C/-55°C and 25°C/+125°C, 25°C is the reference temperature
Short Time Overload	±(1.0%+0.05Ω)	±(2.0%+0.05Ω)	<50mΩ	JIS-C-5201-1 4.13 IEC-60115-1 4.13 RCWV*2.5 or Max. Overload Voltage whichever is lower for 5 seconds, 2 seconds for high power series
Insulation Resistance	≥10G			JIS-C-5201-1 4.6 IEC-60115-1 4.6 Max. Overload Voltage for 1 minute
Endurance	±(2.0%+0.10Ω)	±(3.0%+0.10Ω)	<100mΩ	JIS-C-5201-1 4.25 IEC-60115-1 4.25.1 70±2°C, RCWV for 1000 hrs with 1.5 hrs "ON" and 0.5 hr "OFF"
Damp Heat with Load	±(2.0%+0.10Ω)	±(3.0%+0.10Ω)	<100mΩ	JIS-C-5201-1 4.24 IEC-60115-1 4.24 40±2°C, 90-95% R.H., RCWV for 1000 hrs with 1.5 hrs "ON" and 0.5 hr "OFF"
Dry Heat	±(1.0%+0.05Ω)	±(1.5%+0.10Ω)	<50mΩ	JIS-C-5201-1 4.23 IEC-60115-1 4.23.2 at +125/+155°C for 1000 hrs
Bending Strength	±(1.0%+0.05Ω)	±(1.0%+0.05Ω)	<50mΩ	JIS-C-5201-1 4.33 IEC-60115-1 4.33 Bending once for 5 seconds 2010, 2512 sizes: 2mm Other sizes: 3mm
Solderability	95% min. coverage			JIS-C-5201-1 4.17 IEC-60115-1 4.17 245±5°C for 3 seconds
Resistance to Soldering Heat	±(0.5%+0.05Ω)	±(1.0%+0.05Ω)	<50mΩ	JIS-C-5201-1 4.18 IEC-60115-1 4.18 260±5°C for 10 seconds
Voltage Proof	No breakdown or flashover			JIS-C-5201-1 4.7 IEC-60115-1 4.7 1.42 times Max. Operating Voltage for 1 minute
Leaching	Individual leaching area ≤5% Total leaching area ≤10%			JIS-C-5201-1 4.18 IEC-60068-2-58 8.2.1 260±5°C for 30 seconds
Rapid Change of Temperature	±(0.5%+0.05Ω)	±(1.0%+0.05Ω)	<50mΩ	JIS-C-5201-1 4.19 IEC-60115-1 4.19 -55°C to +125/+155°C, 5 cycles
Sulfur Test	±(0.5%+0.05Ω)	±(0.5%+0.05Ω)	<50mΩ	ASTM-B-809-95 H2S, 50±2°C, 91-93% R.H., no power rating for 1000 hrs

RCWV(Rated Continuous Working Voltage)=√(P\*R) or Max. Operating Voltage whichever is lower.

Storage Temperature: 15-28°C; Humidity: < 80%RH

## Looking for pricing, stock, or lifecycle information?

Click below to explore more details on WIN SOURCE:

-  [View CRS0603-16W-474JT on WIN SOURCE](#)
-  [Venkel Information](#)

## Optimize Your Supply Chain with WIN SOURCE Solutions

-  Global Sourcing Solution
-  Obsolete Management
-  Cost Control Management
-  Shortage Management
-  Alternative Solution
-  Excess Inventory Management