



**THE DATASHEET OF
QTLP320CR**



RED QTLP320C-R ORANGE QTLP320C-E YELLOW QTLP320C-Y

PACKAGE DIMENSIONS

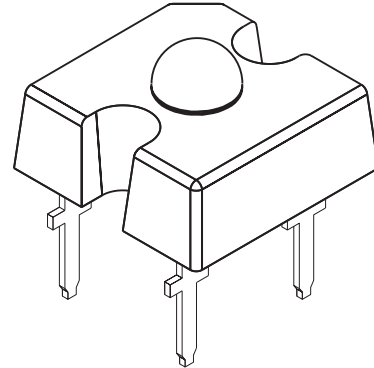
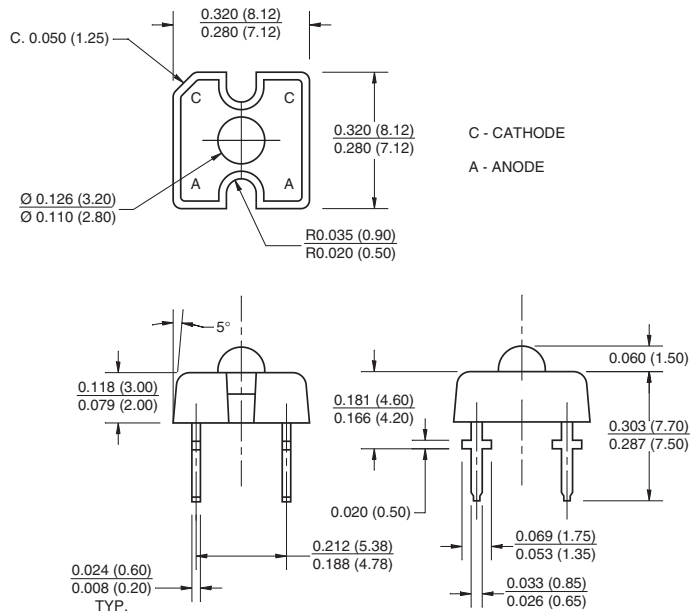

NOTES:

1. Dimensions for all drawings are in inches (mm).
2. Lead spacing is measured where the leads emerge from the package.
3. Protruded resin under the flange is 0.059" (1.5 mm) max.
4. All tolerances are ± 0.10 " (0.25 mm) unless otherwise specified.

DESCRIPTION

This low profile, 4-pin LED provides a more uniform and evenly distributed illumination than existing LED designs. Its unique optical package enables designers to utilize fewer LEDs while achieving superior lighting performance.

FEATURES

- AllnGaP (Aluminum Indium Gallium Phosphide) technology
- High current application
- Reduced thermal resistance
- Tube packaging

APPLICATIONS

- Exterior automotive lighting
- Area displays
- Backlighting
- Message panels

RED QTLP320C-R ORANGE QTLP320C-E YELLOW QTLP320C-Y

ABSOLUTE MAXIMUM RATINGS ($T_A = 25^\circ\text{C}$ unless otherwise specified)			
Parameter	Symbol	Rating	Unit
Operating Temperature	T_{OPR}	-40 to +100	$^\circ\text{C}$
Storage Temperature	T_{STG}	-40 to +100	$^\circ\text{C}$
Lead Soldering Time	T_{SOL}	260 for 5 sec	$^\circ\text{C}$
Continuous Forward Current	I_F	70	mA
Peak Forward Current ($f = 100\text{ Hz}$, Duty Factor = 1/10)	I_F	200	mA
Reverse Voltage	V_R	5	V
Reverse Current	I_R	10	μA
Power Dissipation	P_D	160	mW

ELECTRICAL/OPTICAL CHARACTERISTICS ($T_A = 25^\circ\text{C}$)				
Part Number	QTLP320C-R	QTLP320C-E	QTLP320C-Y	Condition
Luminous Flux (lm)				$I_F = 70\text{ mA}$
Minimum	500	500	500	
Typical	1300	1300	1300	
Forward Voltage V_F (V)				$I_F = 70\text{ mA}$
Maximum	2.9	2.9	2.9	
Typical	2.3	2.3	2.3	
Wavelength (nm)				$I_F = 70\text{ mA}$
Peak	630	620	590	
Dominant	625	615	589	
Spectral Line Half Width (nm)	20	18	15	$I_F = 70\text{ mA}$
Viewing Angle ($^\circ$)	70	70	70	$I_F = 70\text{ mA}$

RED QTLP320C-R ORANGE QTLP320C-E YELLOW QTLP320C-Y

TYPICAL PERFORMANCE CURVES

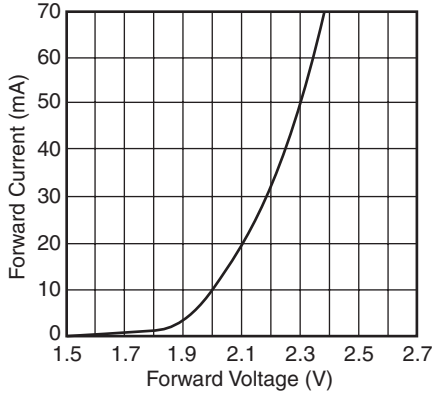

Fig 1. Forward Current vs. Forward Voltage

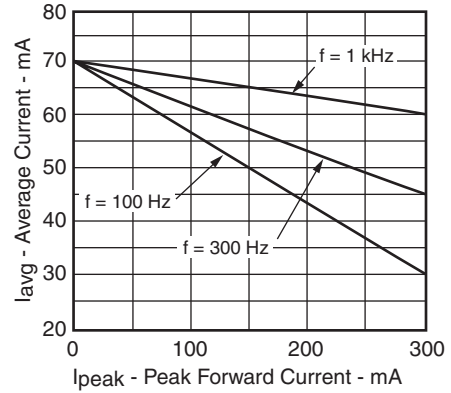

Fig 2. Maximum Average Current vs. Peak Forward Current

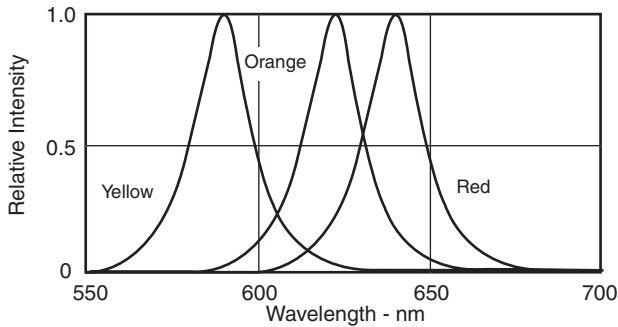

Fig 3. Relative Intensity vs. Peak Wavelength

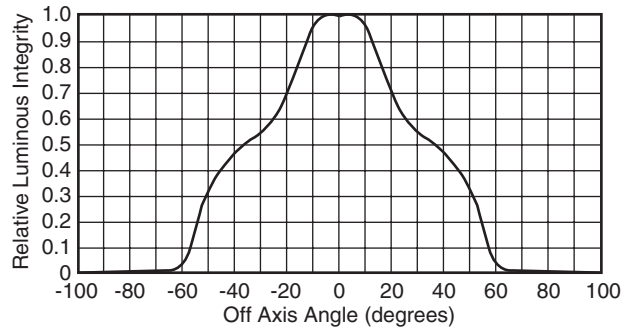

Fig 4. Relative Luminous Intensity vs. Off Axis Angle

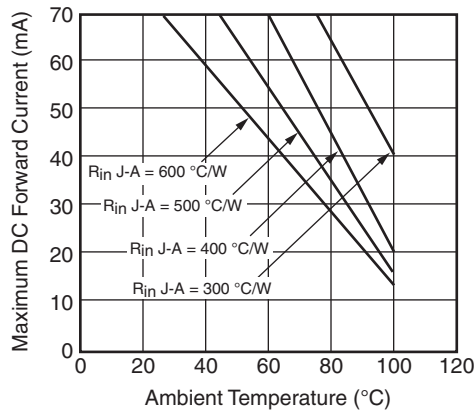

Fig 5. Maximum DC Forward Current vs. Ambient Temperature

RED QTLP320C-R ORANGE QTLP320C-E YELLOW QTLP320C-Y

DISCLAIMER

FAIRCHILD SEMICONDUCTOR RESERVES THE RIGHT TO MAKE CHANGES WITHOUT FURTHER NOTICE TO ANY PRODUCTS HEREIN TO IMPROVE RELIABILITY, FUNCTION OR DESIGN. FAIRCHILD DOES NOT ASSUME ANY LIABILITY ARISING OUT OF THE APPLICATION OR USE OF ANY PRODUCT OR CIRCUIT DESCRIBED HEREIN; NEITHER DOES IT CONVEY ANY LICENSE UNDER ITS PATENT RIGHTS, NOR THE RIGHTS OF OTHERS.

LIFE SUPPORT POLICY

FAIRCHILD'S PRODUCTS ARE NOT AUTHORIZED FOR USE AS CRITICAL COMPONENTS IN LIFE SUPPORT DEVICES OR SYSTEMS WITHOUT THE EXPRESS WRITTEN APPROVAL OF THE PRESIDENT OF FAIRCHILD SEMICONDUCTOR CORPORATION. As used herein:

1. Life support devices or systems are devices or systems which, (a) are intended for surgical implant into the body, or (b) support or sustain life, and (c) whose failure to perform when properly used in accordance with instructions for use provided in the labeling, can be reasonably expected to result in a significant injury of the user.
2. A critical component in any component of a life support device or system whose failure to perform can be reasonably expected to cause the failure of the life support device or system, or to affect its safety or effectiveness.

Looking for pricing, stock, or lifecycle information?

Click below to explore more details on WIN SOURCE:

 [View QTLP320CR](#) on WIN SOURCE

 [ON Semiconductor](#) Information

Optimize Your Supply Chain with WIN SOURCE Solutions

-  Global Sourcing Solution
-  Obsolete Management
-  Cost Control Management
-  Shortage Management
-  Alternative Solution
-  Excess Inventory Management