

**DESIGNED & DIMENSIONED
IN MILLIMETERS [INCHES] QSFP8-XXX-01-X-D-RA1-XX**

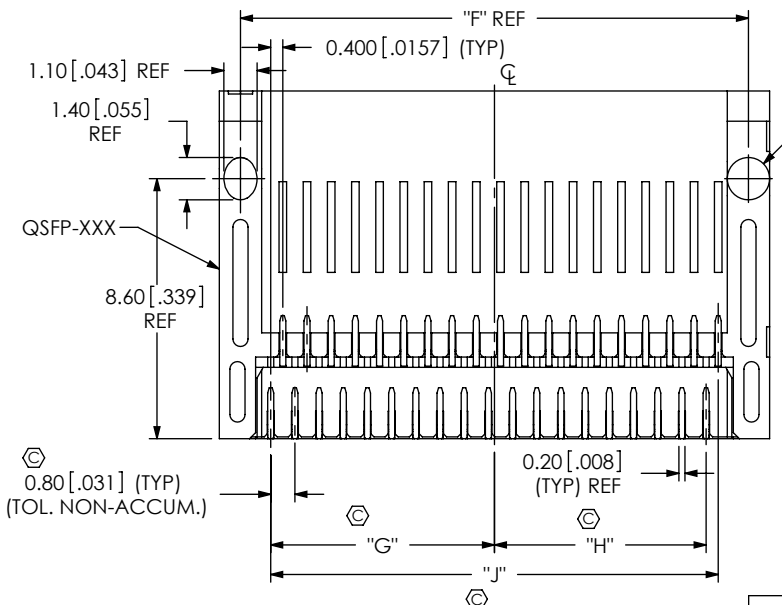
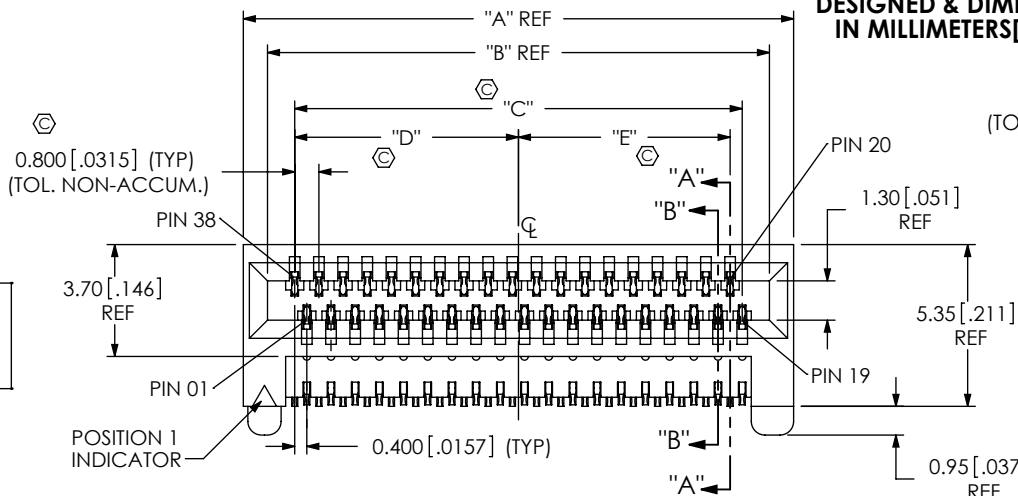

No. OF POSITIONS
* -020, -038, *-100
(TOTAL NUMBER OF POSITIONS)

LEAD STYLE
-01

PACKAGING
BLANK: TUBES (SEE NOTE 4)
-TR: TAPE & REEL (SEE NOTE 5 & 6)
-FR: FULL REEL QTY TAPE & REEL (SEE NOTE 5 & 6)

PLATING SPECIFICATION
-L: 10u" MIN Au/50u"Ni IN CONTACT, TIN ON TAIL
(* = NOT TOOLED)

SMT TYPE
-RA1: RIGHT ANGLE

ROW SPECIFICATION
-D: DOUBLE ROW

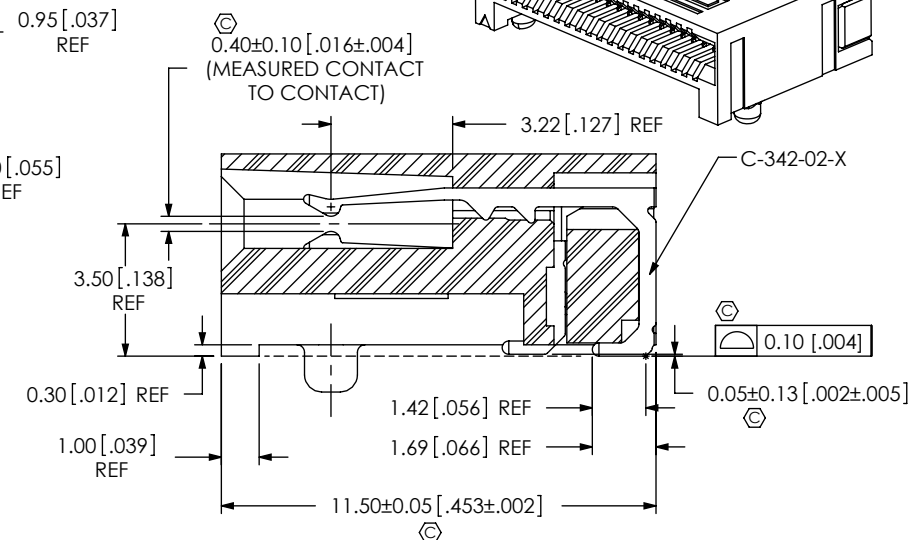
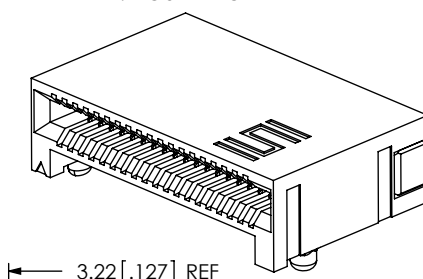

FIG 1
QSFP8-038-01-X-D-RA1 SHOWN
SECTION "A"- "A"
SCALE 5 : 1

TABLE 1

No. OF POS	"A"	"B"	"C"	"D"	"E"	"F"
*-020	11.00 [0.433]	9.40 [0.370]	7.60 [0.299]	3.80 [0.150]	3.40 [0.134]	9.60 [0.378]
-038	18.20 [0.717]	16.60 [0.654]	14.80 [0.583]	7.40 [0.291]	7.00 [0.276]	16.80 [0.661]
*-100	43.00 [1.693]	41.40 [1.630]	39.60 [1.559]	19.80 [0.780]	19.40 [0.764]	41.60 [1.638]

(* = NOT TOOLED)

UNLESS OTHERWISE SPECIFIED, DIMENSIONS ARE IN MILLIMETERS. TOLERANCES ARE: DECIMALS ANGLES X.X: ±0.3 [.01] 2° X.XX: ±0.13 [.005] X.XXX: ±0.051 [.0020]	PROPRIETARY NOTE THIS DOCUMENT CONTAINS CONFIDENTIAL AND PROPRIETARY INFORMATION AND ALL DESIGN, MANUFACTURING, REPRODUCTION, USE, PATENT RIGHTS AND SALES RIGHTS ARE EXPRESSLY RESERVED BY SAMTEC, INC. THIS DOCUMENT SHALL NOT BE DISCLOSED, IN WHOLE OR PART, TO ANY UNAUTHORIZED PERSON OR ENTITY NOR REPRODUCED, TRANSFERRED OR INCORPORATED IN ANY OTHER PROJECT IN ANY MANNER WITHOUT THE EXPRESS WRITTEN CONSENT OF SAMTEC, INC.	<p>520 PARK EAST BLVD, NEW ALBANY, IN 47150 PHONE: 812-944-6733 FAX: 812-948-5047 e-Mail: info@SAMTEC.com code 53322</p>
	MATERIAL: DO NOT SCALE DRAWING SHEET SCALE: 4:1 INSULATOR: LCP, COLOR: BLACK CONTACT: PHOS BRONZE	

DO NOT SCALE FROM THIS PRINT

TABLE 2

No. OF POS	"G"	"H"	"J"
*-020	3.80 [0.150]	3.40 [0.134]	7.60 [0.299]
-038	7.40 [0.291]	7.00 [0.276]	14.80 [0.583]
*-100	19.80 [0.780]	19.40 [0.764]	39.60 [1.559]

(* = NOT TOOLED)

- NOTES:
- ⊗ REPRESENTS A CRITICAL DIMENSION.
 - MINIMUM PUSHOUT FORCE: 1.11N [0.25 LB].
 - NOTE DELETED.
 - TUBES ARE STANDARD PACKAGING.
 - ORDERS WILL BE PACKAGED ACCORDING TO THE SAMTEC PACKAGING EFFICIENCY STANDARDS (SPES) FOUND ON WWW.SAMTEC.COM
 - ATTACH LABEL TO EACH REEL

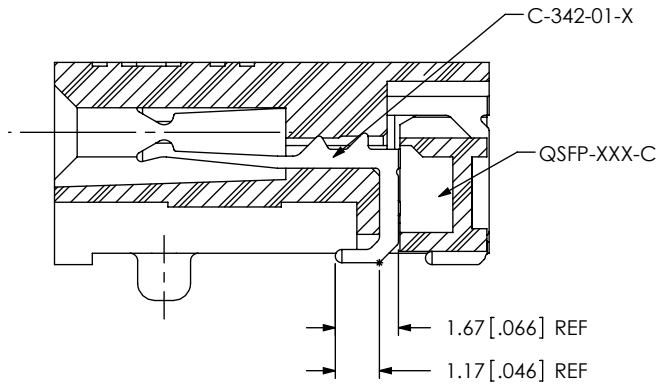

SECTION "B"-"B"
SCALE 5 : 1

(SAME AS SECTION "A"-"A", EXCEPT AS SHOWN)

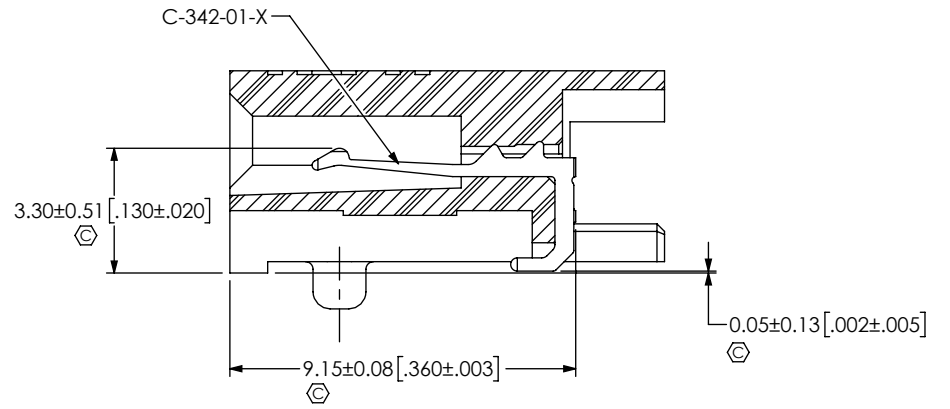
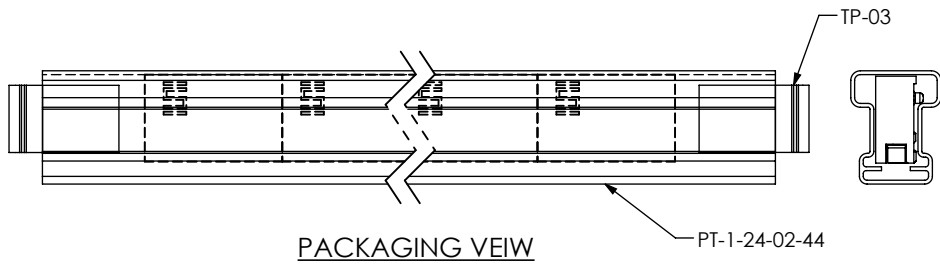

IN-PROCESS 1
(FILL QSFP-XXX-C)

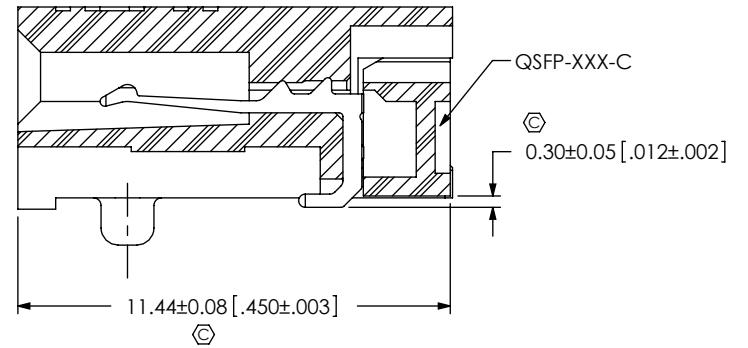

IN-PROCESS 2
(FILL QSFP-XXX-C)

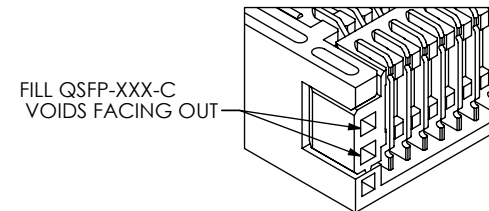

PROPRIETARY NOTE
THIS DOCUMENT CONTAINS CONFIDENTIAL AND PROPRIETARY INFORMATION AND ALL DESIGN, MANUFACTURING, REPRODUCTION, USE, PATENT RIGHTS AND SALES RIGHTS ARE EXPRESSLY RESERVED BY SAMTEC, INC. THIS DOCUMENT SHALL NOT BE DISCLOSED, IN WHOLE OR PART, TO ANY UNAUTHORIZED PERSON OR ENTITY NOR REPRODUCED, TRANSFERRED OR INCORPORATED IN ANY OTHER PROJECT IN ANY MANNER WITHOUT THE EXPRESS WRITTEN CONSENT OF SAMTEC, INC.

DO NOT SCALE DRAWING

SHEET SCALE: 4:1

samtec

520 PARK EAST BLVD, NEW ALBANY, IN 47150
PHONE: 812-944-6733 FAX: 812-948-5047
e-Mail info@SAMTEC.com code 55322

DESCRIPTION: QSFP8 ASM

DWG. NO. QSFP8-XXX-01-X-D-RA1-XX

BY: ROY LUO 7/20/2010 SHEET 2 OF 2

Looking for pricing, stock, or lifecycle information?

Click below to explore more details on WIN SOURCE:

- [View QSFP8-038-01-L-D-RA1-TR on WIN SOURCE](#)
- [Samtec Inc. Information](#)

Optimize Your Supply Chain with WIN SOURCE Solutions

- ✓ Global Sourcing Solution
- ✓ Obsolete Management
- ✓ Cost Control Management
- ✓ Shortage Management
- ✓ Alternative Solution
- ✓ Excess Inventory Management