



**THE DATASHEET OF  
QN9020/DY**





# QN902x

## Ultra low power Bluetooth LE system-on-chip solution

Rev. 2.7 — 21 November 2018

Product data sheet

### 1. Introduction

---

QN902x is an ultra low power, wireless System-on-Chip (SoC) for Bluetooth Smart applications. It supports both master and slave modes. QN902x integrates a high performance 2.4 GHz RF transceiver with a 32-bit ARM Cortex-M0 MCU, flash memory, and analog and digital peripherals.

By integrating a Bluetooth LE v4.2 compliant radio, link controller and host stack, QN902x provides a single-chip solution for Bluetooth Smart applications. The 32-bit ARM Cortex-M0 MCU and on-chip memory provides additional signal processing and room to run applications for a true single-chip Bluetooth Smart solution. In addition, QN902x can be used as a network processor by connecting to an application processor via UART or SPI. It helps to add Bluetooth Smart feature to any product.

QN902x has built-in analog and digital interfaces. It enables easy connection to any analog or digital peripheral, sensor, and external application processor in network processor mode.

### 2. General description

---

QN902x is an ultra low power, high performance and highly integrated Bluetooth LE solution. It is used in Bluetooth Smart applications such as sports and fitness, human interface devices, and app-enabled smart accessories. It is specially designed for wearable electronics and can run on a small capacity battery such as a coin cell battery.

QN902x integrates a Bluetooth LE radio, controller, protocol stack and profile software on a single chip, providing a flexible and easy to use Bluetooth LE SoC solution. It also has a high performance MCU and an on-chip memory that can support users to develop a single-chip wireless MCU solution. Users can also utilize QN902x as a network processor by connecting to an application processor for more advanced applications.

Additional system features include fully integrated DC-to-DC converter and LDO, low-power sleep timer, battery monitor, general-purpose ADC, and GPIOs. These features reduce overall system cost and size. QN902x has very low power consumption in all modes. It enables long life in battery-operated systems while maintaining excellent RF performance. QN9020/1 operates with a power supply range of 2.4 V to 3.6 V. The QN9022 operates with a power supply range of 1.8 V to 3.6 V.

### 3. Features and benefits

---

- True single-chip Bluetooth LE SoC solution
  - ◆ Integrated Bluetooth LE radio
  - ◆ Complete Bluetooth LE protocol stack and application profiles



- ◆ Supports both master and slave modes
- ◆ Supports secure connections
- ◆ Up to eight simultaneous links in master mode
- ◆ Frequency bands: 2400 MHz to 2483.5 MHz
- ◆ 1 Mbit/s on air data rate and 250 kHz deviation
- ◆ GFSK modulation format
- RF
  - ◆ –95 dBm RX sensitivity (non-DC-to-DC mode)
  - ◆ –93 dBm RX sensitivity (DC-to-DC mode)
  - ◆ TX output power from –20 dBm to +4 dBm
  - ◆ Fast and reliable RSSI and channel quality indication
  - ◆ Compatible with worldwide radio frequency regulations
  - ◆ Excellent link budget up to 99 dB
- Very low power consumption
  - ◆ Single power supply of 2.4 V to 3.6 V for QN9020/1
  - ◆ Single power supply of 1.8 V to 3.6 V for QN9022
  - ◆ Integrated DC-to-DC converter and LDO
  - ◆ 2  $\mu$ A deep sleep mode
  - ◆ 3  $\mu$ A sleep mode (32 kHz RC oscillator on)
  - ◆ 9.25 mA RX current with DC-to-DC converter
  - ◆ 8.8 mA TX current @0 dBm TX power with DC-to-DC converter
- Compact 6 mm  $\times$  6 mm HVQFN48 package for QN9020, 5 mm  $\times$  5 mm HVQFN32 package for QN9021, and 5 mm  $\times$  5 mm HVQFN40 package for QN9022
- Microcontroller
  - ◆ Integrated 32-bit ARM Cortex-M0 MCU
  - ◆ 64 kB system memory
  - ◆ 96 kB ROM
  - ◆ 128 kB on-chip flash memory with 4 kB page size for QN9020 and QN9021
  - ◆ User-controllable code protection
- High-level integration
  - ◆ 4-channel, 10-bit general-purpose ADC
  - ◆ Two general-purpose analog comparators
  - ◆ 31 GPIO pins for QN9020, 15 GPIO pins for QN9021, and 22 GPIO pins for QN9022
  - ◆ GPIO pins can be used as interrupt sources
  - ◆ Four general-purpose timers
  - ◆ 32 kHz sleep timer
  - ◆ Watchdog timer
  - ◆ Real-time clock with calibration
  - ◆ 2-channel programmable PWM
  - ◆ Two SPI/UART interfaces
  - ◆ I<sup>2</sup>C-bus master/slave interface
  - ◆ Brownout detector
  - ◆ Battery monitor
  - ◆ AES-128 security coprocessor

- ◆ 16 MHz or 32 MHz crystal oscillator
- ◆ Low power 32 kHz RC oscillator
- ◆ 32.768 kHz crystal oscillator

## 4. Applications

- Sports and fitness
- Healthcare and medical
- Remote control
- Smartphone accessories
- PC peripherals (mouse and keyboard)
- Wireless sensor networks

## 5. Profiles and services

QN902x offers a complete list of qualified profiles and services.

**Table 1. Supported profiles and services**

Profiles and services	Version
Device information service	1.1
Battery service	1.0
Blood pressure profile	1.0
Find me profile	1.0
Glucose profile	1.0
Heart rate profile	1.0
Health thermometer profile	1.0
HID over GATT profile	1.0
Proximity profile	1.0
Scan parameters profile	1.0
Time profile	1.0
Alert notification profile	1.0
Phone alert status profile	1.0
Cycling speed and cadence profile	1.0
Running speed and cadence profile	1.0

## 6. Ordering information

Table 2. Ordering information

Type number	Package		
	Name	Description	Version
QN9020	HVQFN48	plastic thermal enhanced very thin quad flat package; no leads; 48 terminals; body 6 × 6 × 0.85 mm	SOT778-4
QN9021	HVQFN32	plastic thermal enhanced very thin quad flat package; no leads; 32 terminals; body 5 × 5 × 0.85 mm	SOT617-13
QN9022	HVQFN40	plastic thermal enhanced very thin quad flat package; no leads; 40 terminals; body 5 × 5 × 0.85 mm	SOT1369-2

## 7. Block diagram

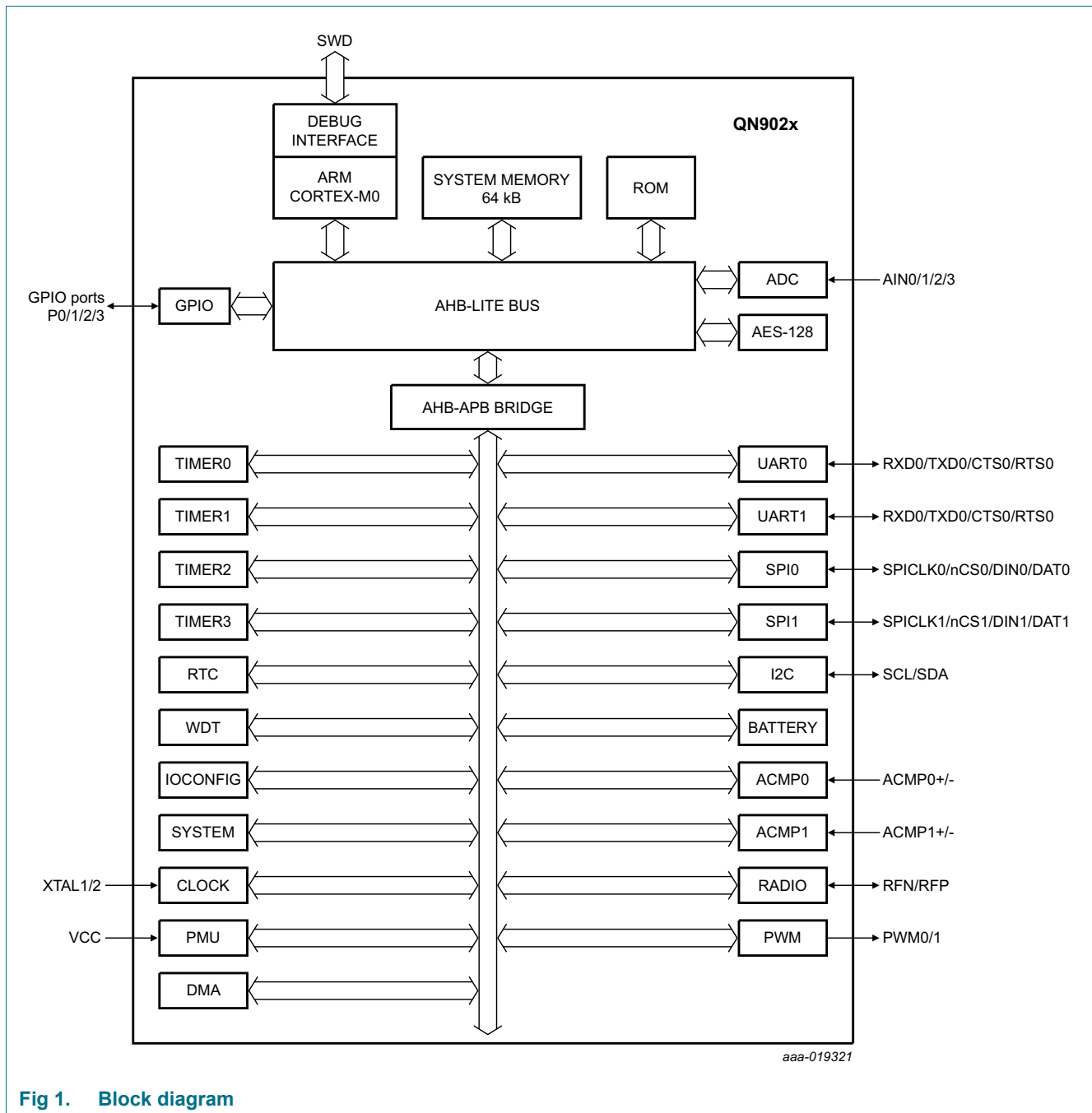
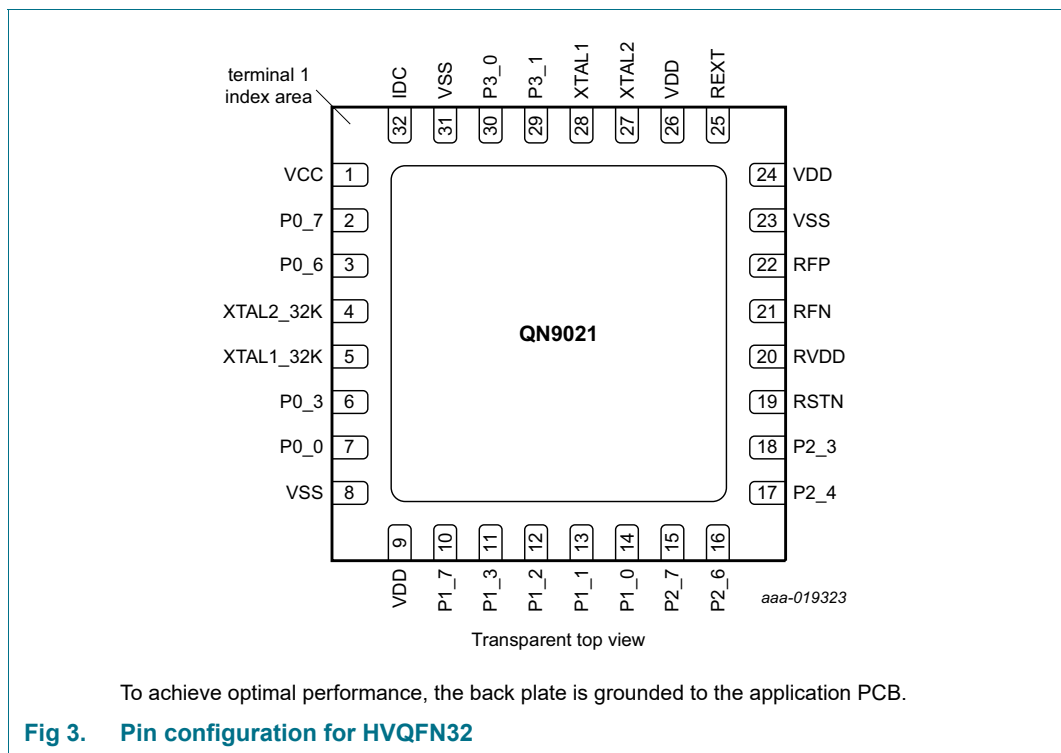
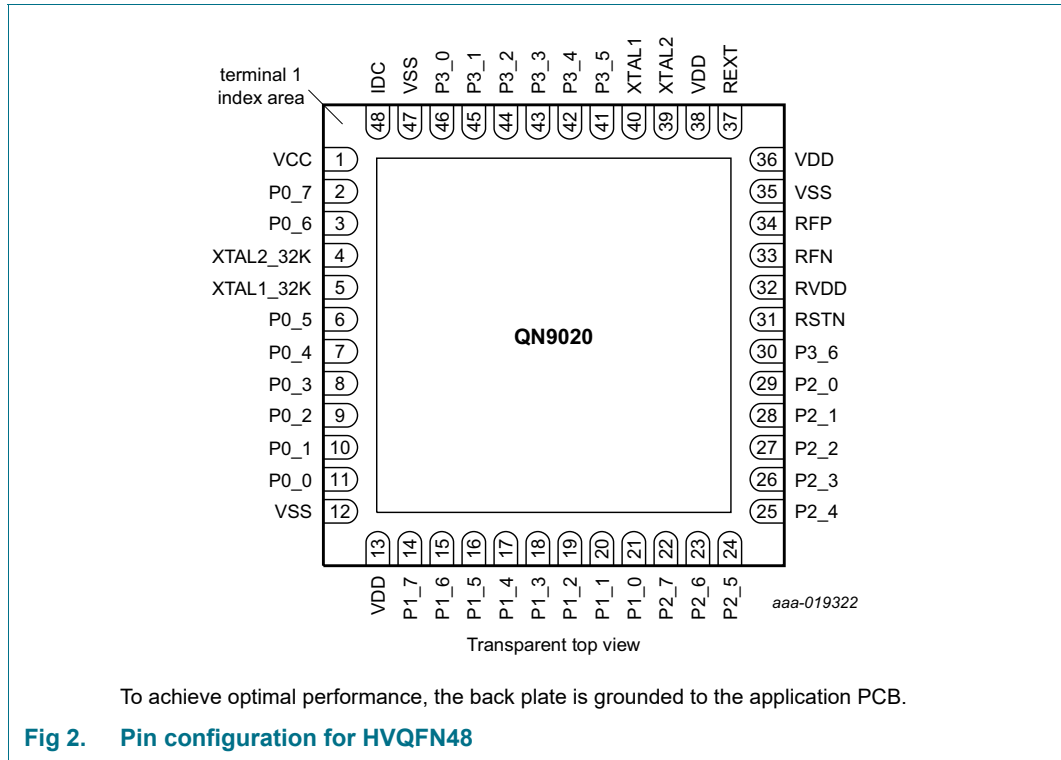
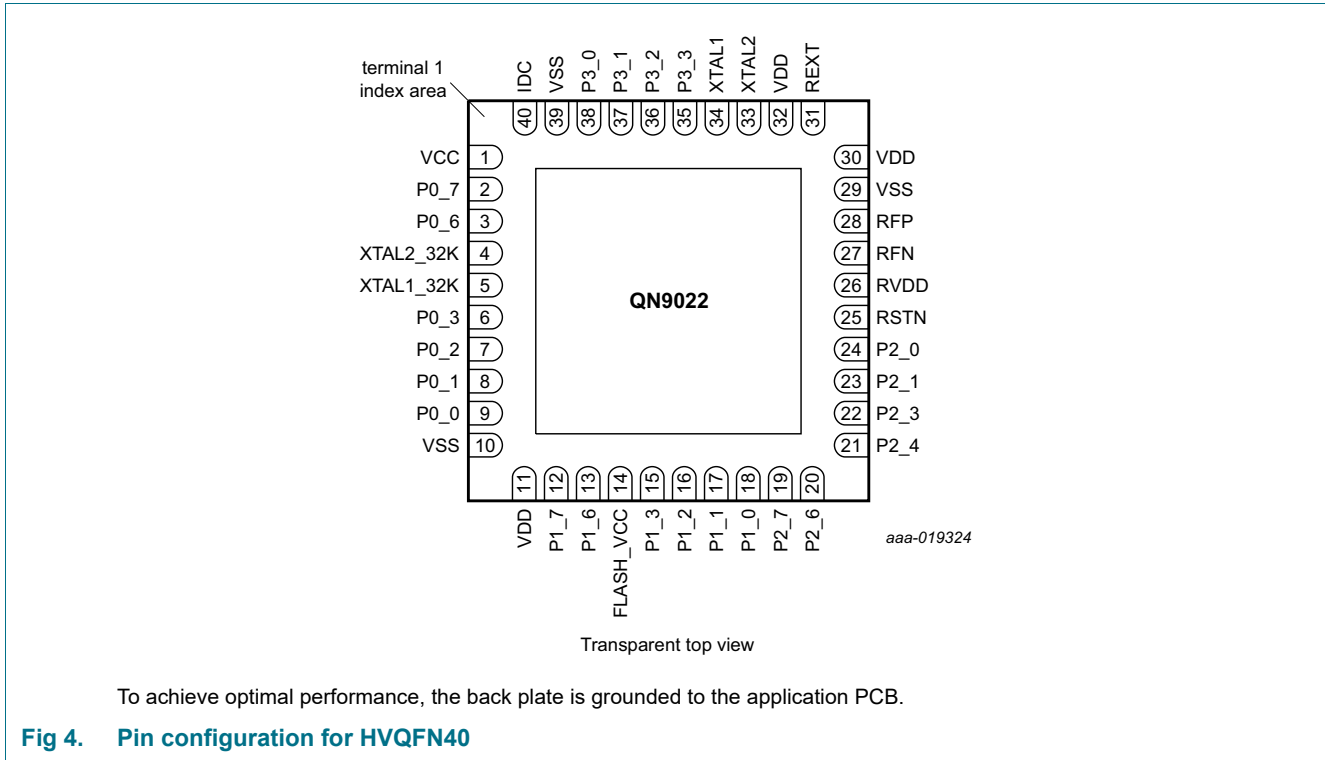

Fig 1. Block diagram

## 8. Pinning information

### 8.1 Pinning





## 8.2 Pin description

**Table 3. Pin description**

I = Input; O = Output; I/O = Input/Output; AI = Analog Input.

Symbol	Pin			Alternate function	Type	Description
	QN9020	QN9021	QN9022			
VCC	1	1	1	-	-	supply voltage
P0_7	2	2	2	SWCLK	I	default to SWCLK (input with pull-up)
				P0_7	I/O	GPIO7
				AIN3	AI	ADC input channel 3
				ACMP1-	AI	analog comparator 1 negative input
P0_6	3	3	3	SWDIO	I/O	default to SWDIO (input with pull-up)
				P0_6	I/O	GPIO6
				AIN2	AI	ADC input channel 2
				ACMP1+	AI	analog comparator 1 positive input
XTAL2_32K	4	4	4	-	-	connected to 32.768 kHz crystal or external 32 kHz clock; if RC oscillator is used, this pin is not connected
XTAL1_32K	5	5	5	-	-	connected to 32.768 kHz crystal; if RC oscillator is used, this pin is not connected
P0_5	6	-	-	P0_5	I/O	GPIO5
				SCL	I/O	I <sup>2</sup> C-bus clock
				ADCT	I	ADC conversion external trigger
				ACMP1_O	O	analog comparator 1 output

Table 3. Pin description ...continued

I = Input; O = Output; I/O = Input/Output; AI = Analog Input.

Symbol	Pin			Alternate function	Type	Description
	QN9020	QN9021	QN9022			
P0_4	7	-	-	P0_4	I/O	GPIO4
				CLKOUT1	O	clock output 1
				RTCI	I	RTC input capture
P0_3	8	6	6	P0_3	I/O	GPIO3
				CLKOUT0	O	clock output 0
				T0_ECLK	I/O	timer 0 external clock input or PWM output
P0_2	9	-	7	P0_2	I/O	GPIO2
				SDA	I/O	I <sup>2</sup> C-bus data transmit
				SPICLK0	I/O	SPI0 clock
				RTS0	O	UART0 RTS
P0_1	10	-	8	P0_1	I/O	GPIO1
				nCS0_0	I/O	SPI0 slave select for master/slave mode
				CTS0	I	UART0 CTS
P0_0	11	7	9	P0_0	I/O	GPIO0
				TXD0	O	UART0 TX data output with pull-up
				DAT0	I/O	in 4-wire mode, SPI0 output data; in 3-wire mode, data I/O
				RTCI	I	RTC input capture
VSS	12	8	10	-	-	ground
VDD	13	9	11	-	-	supply voltage
P1_7	14	10	12	P1_7	I/O	GPIO15
				RXD0	I	UART0 RX data input
				DIN0	I	SPI0 input data in 4-wire mode; invalid in 3-wire mode
				T0_0	O	timer 0 PWM output
P1_6	15	-	13	P1_6	I/O	GPIO14
				nCS0_1	O	SPI0 slave select output for master mode
				PWM0	O	PWM0 output
				T0_3	I/O	timer 0 input capture/clock or PWM output
FLASH_VCC	-	-	14	-	-	power output for flash <sup>[1]</sup>
P1_5	16	-	-	P1_5	I/O	GPIO13
				PWM1	O	PWM1 output
				T1_2	I/O	timer 1 input capture/clock or PWM output
P1_4	17	-	-	P1_4	I/O	GPIO12
				T1_3	I/O	timer 1 input capture/clock or PWM output
P1_3	18	11	15	P1_3	I/O	GPIO11
				SPICLK1	I/O	SPI1 clock
				RTS1	O	UART1 RTS
				CLKOUT1	O	clock output 1

Table 3. Pin description ...continued

I = Input; O = Output; I/O = Input/Output; AI = Analog Input.

Symbol	Pin			Alternate function	Type	Description
	QN9020	QN9021	QN9022			
P1_2	19	12	16	P1_2	I/O	GPIO10
				nCS1_0	I/O	SPI1 slave select for master/slave mode
				CTS1	I	UART1 CTS
				ADCT	AI	ADC conversion external trigger
P1_1	20	13	17	P1_1	I/O	GPIO9
				DAT1	I/O	in 4-wire mode, SPI1 output data; in 3-wire mode, data I/O
				TXD1	O	UART1 TX data
				T1_0	I/O	timer 1 input capture/clock or PWM output
P1_0	21	14	18	P1_0	I/O	GPIO8
				DIN1	I	SPI1 input data in 4-wire mode; invalid in 3-wire mode
				RXD1	I	UART1 RX data
				T2_ECLK	I/O	timer 2 external clock input or PWM output
P2_7	22	15	19	P2_7	I/O	GPIO23
				ACMP1_O	O	analog comparator 1 output
				PWM0	O	PWM0 output
				T1_ECLK	I/O	timer 1 external clock input or PWM output
P2_6	23	16	20	P2_6	I/O	GPIO22, pull up to bypass ISP mode and enable fast boot function during boot process.
				PWM1	O	PWM1 output
				T2_0	I/O	timer 2 input capture/clock or PWM output
P2_5	24	-	-	P2_5	I/O	GPIO21
				nCS1_1	O	SPI1 slave select output for master mode
				T2_2	I/O	timer 2 input capture/clock or PWM output
P2_4	25	17	21	P2_4	I/O	GPIO20
				SCL	I/O	I <sup>2</sup> C-bus master clock output with pull-up
				PWM1	O	PWM1 output
				T3_ECLK	I/O	timer 3 external clock input or PWM output
P2_3	26	18	22	P2_3	I/O	GPIO19
				SDA	I/O	I <sup>2</sup> C-bus data transmit
				ACMP0_O	O	analog comparator 0 output
				T3_0	I/O	timer 3 input capture/clock or PWM output
P2_2	27	-	-	P2_2	I/O	GPIO18
				SPICLK1	I/O	SPI1 clock
				RTS1	O	UART1 RTS
				T2_3	I/O	timer 2 input capture/clock or PWM output

Table 3. Pin description ...continued

I = Input; O = Output; I/O = Input/Output; AI = Analog Input.

Symbol	Pin			Alternate function	Type	Description
	QN9020	QN9021	QN9022			
P2_1	28	-	23	P2_1	I/O	GPIO17
				DAT1	I/O	in 4-wire mode, SPI0 output data; in 3-wire mode, data I/O
				TXD1	O	UART1 TX data output with pull-up
				T3_1	I/O	timer 3 input capture/clock or PWM output
P2_0	29	-	24	P2_0	I/O	GPIO16
				DIN1	I	SPI1 input data in 4-wire mode; invalid in 3-wire mode
				RXD1	I	UART1 RX data input
				T3_2	I/O	timer 3 input capture/clock or PWM output
P3_6	30	-	-	P3_6	I/O	GPIO30
				nCS1_0	I/O	SPI1 slave select for master/slave mode
				CTS1	I	UART1 CTS
RSTN	31	19	25	-	-	hardware reset, active LOW
RVDD	32	20	26	-	-	regulated PA power output
RFN	33	21	27	-	-	differential RF port
RFP	34	22	28	-	-	differential RF port
VSS	35	23	29	-	-	analog ground
VDD	36	24	30	-	-	analog power supply
REXT	37	25	31	-	-	current reference terminal, connect 56 kΩ ± 1 % resistor to ground
VDD	38	26	32	-	-	analog power supply
XTAL2	39	27	33	-	-	connected to 16 MHz or 32 MHz crystal
XTAL1	40	28	34	-	-	connected to 16 MHz or 32 MHz crystal
P3_5	41	-	-	P3_5	I/O	GPIO29
				nCS0_0	I/O	SPI0 slave select for master/slave mode
				T0_0	I/O	timer 0 input capture/clock or PWM output
P3_4	42	-	-	P3_4	I/O	GPIO28
				SPICLK0	I/O	SPI0 clock
P3_3	43	-	35	P3_3	I/O	GPIO27
				DAT0	I/O	in 4-wire mode, SPI0 output data; in 3-wire mode, data I/O
				CLKOUT0	O	clock output 0
P3_2	44	-	36	P3_2	I/O	GPIO26
				DIN0	I	SPI0 input data in 4-wire mode; invalid in 3-wire mode
				ACMP0_O	O	analog comparator 0 output
P3_1	45	29	37	P3_1	I/O	GPIO25
				T0_2	I/O	timer 0 input capture/clock or PWM output
				AIN1	I	ADC input channel 1
				ACMP0-	I	analog comparator 0 negative input

**Table 3. Pin description ...continued***I = Input; O = Output; I/O = Input/Output; AI = Analog Input.*

Symbol	Pin			Alternate function	Type	Description
	QN9020	QN9021	QN9022			
P3_0	46	30	38	P3_0	I/O	GPIO24
				T2_1	I/O	timer 1 input capture/clock or PWM output
				AIN0	AI	ADC input channel 0
				ACMP0+	AI	analog comparator 0 positive input
VSS	47	31	39	-	-	ground
IDC	48	32	40	-	-	if DC-to-DC is enabled, PWM driver is used for LC filter; if DC-to-DC is disabled, this pin is not connected

[1] Available only in QN9022.

## 9. Functional description

QN902x integrates an ultra low power 2.4 GHz radio, a qualified software stack and application profiles on a single chip. The integrated Power Management Unit (PMU) controls the system operation in different power states, to ensure low-power operation. The high-frequency crystal oscillator provides the reference frequency for the radio transceiver, while the low-frequency oscillators maintain timing in sleep states.

The integrated AES coprocessor supports encryption with minimal MCU usage. Minimum MCU usage helps in reducing the load on the MCU and also reduces power consumption. The embedded MCU and additional memory provides additional signal processing capability and helps to run user applications.

QN902x includes a general-purpose ADC with four external independent input channels. The ADC is utilized for power supply voltage monitoring. Digital serial interfaces (SPI/UART/I<sup>2</sup>C) are integrated to communicate with application processor or digital sensors.

The UART supports Bluetooth LE Direct Test Mode (DTM). This interface is used to control the PHY layer with commercially available Bluetooth testers, used for qualification.

I<sup>2</sup>C-bus is integrated and supports both master and slave mode. It can communicate with a digital sensor or EEPROM.

### 9.1 MCU subsystem

The MCU subsystem includes:

- 32-bit ARM Cortex-M0 MCU
- 64 kB system memory
- Reset generation
- Clock and power management unit
- Nested Vectored Interrupt Controller (NVIC)
- Serial Wire Debug (SWD) interface

9.1.1 MCU

The CPU core is a 32-bit ARM Cortex-M0 MCU offering significant benefits to application development. It includes the following:

- Simple, easy-to-use programmers model
- Highly efficient ultra low power operation
- Excellent code density
- Deterministic, high-performance interrupt handling for 32 external interrupt inputs

The processor is extensively optimized for low power and delivers exceptional power efficiency through its efficient instruction set. It provides high-end processing hardware including a single-cycle multiplier.

9.1.2 Memory organization

QN902x has an on-chip system memory of 64 kB, used for storing application program and data. It is secured with a user-configurable protection mode, to prevent unauthorized access. The MCU is 32-bit, with an address space of 4 GB. It is shared between the system memory, ROM, system registers, peripheral registers, and general-purpose memory. The address space ranges from 0x0000 0000 to 0xFFFF FFFF; see [Figure 5](#). The system memory is secured with a user-controllable protection scheme, which prevents unauthorized access.

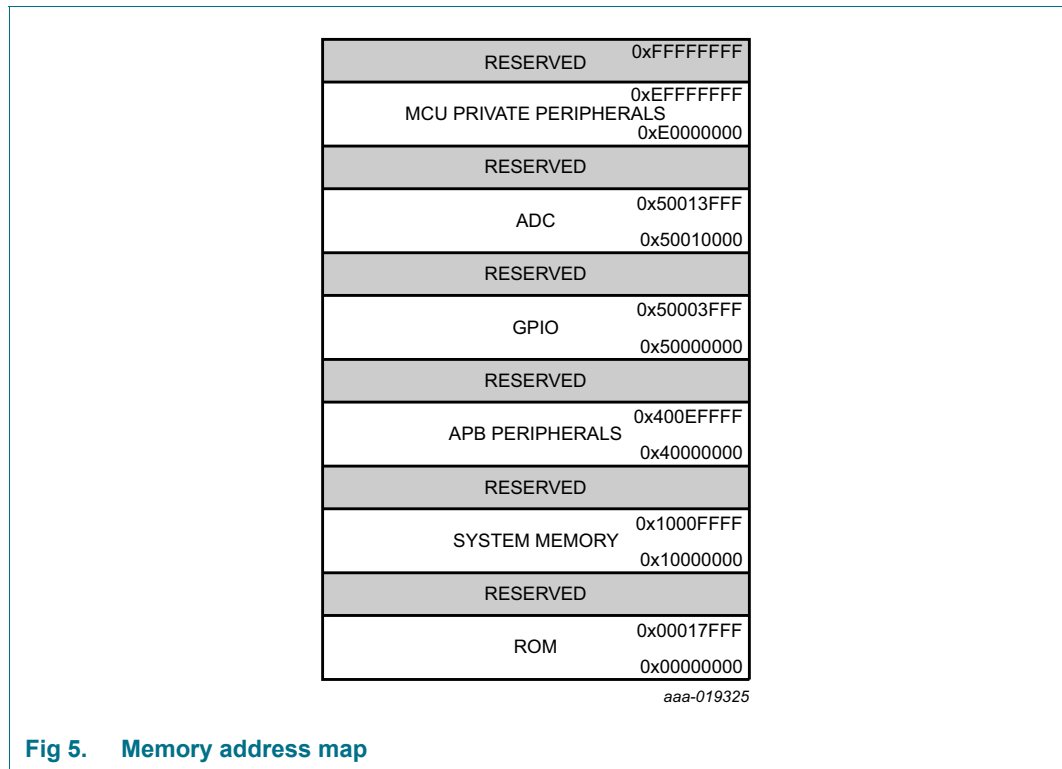

9.1.3 RESET generation

The device has four sources of reset. The following events generate a reset:

- Forcing RSTN pin to LOW

- Power-on
- Brownout
- Watchdog time-out

### 9.1.4 Nested Vectored Interrupt Controller (NVIC)

QN902x supports Cortex-M0 built-in Nested Vectored Interrupt Controller (NVIC) with 24 external interrupt inputs. External interrupt signals are connected to the NVIC and the NVIC prioritizes the interrupts. Software is used to set the priority of each interrupt. The NVIC and Cortex-M0 processor core are closely coupled, providing low-latency interrupt processing and efficient processing of late arriving interrupts.

### 9.1.5 Clock and power management

QN902x provides flexible clocking scheme to balance between performance and power. A high frequency crystal oscillator is utilized to provide reference frequency and system clock. QN902x supports 16 MHz and 32 MHz external crystal with  $\pm 50 \times 10^{-6}$  accuracy. The system clock is 32 MHz or its divided versions.

Two low-speed 32 kHz oscillators are integrated. The 32.768 kHz crystal oscillator is used where accurate timing is needed, while a 32 kHz RC oscillator reduces cost and power consumption. Only one works at a time.

QN902x features ultra low power consumption with two sleep modes, SLEEP and DEEP SLEEP. After the execution of Wait For Interrupt (WFI) instruction, the MCU stops execution, enters into SLEEP mode and stops the clock immediately. Before entering into SLEEP mode, MCU should set the sleep timer correctly and make the 32 kHz clock ready. If DEEP SLEEP mode is entered, it must wait for the external interrupts to wake it up.

When an external interrupt or sleep timer time-out occurs, the Wake-up Interrupt Controller (WIC) enables the system clock. It takes 16 clock cycles to wake up the MCU and restore the states, before MCU can resume program execution to process the interrupt.

Only P0\_0 to P0\_7 and P1\_0 to P1\_7 can wake up MCU out of sleep states. The power management unit controls the power states of the whole chip and switch on/off the supply to different parts, as per the power state.

**Table 4. Power matrix**

Mode	Digital regulator	32 kHz oscillator	Sleep timer	Description
deep sleep	off	off	off	wait for external interrupt to wake it up; RAM and register content retained
sleep	off	on	on	wait for SLEEP TIMER time-out to wake it up; RAM and register content retained
idle	on	on	on	16 MHz or 32 MHz XTAL on; MCU idle
active	on	on	on	radio off; MCU on
radio	on	on	on	radio on

### 9.1.6 Serial Wire Debug (SWD) interface

QN902x provides a standard SWD interface and supports up to four hardware breakpoints and two watch points.

## 9.2 Flash

QN9020/1 have a 128 kB flash. The flash communicates with the MCU by internal SPI interface and can be used to store code or data. The flash has the following features:

- 32 equal sectors of 4 kB each, any sector can be erased individually
- Minimum 100000 erase/program cycles
- RES command, 1-byte command code
- Low power consumption

QN9022 has an interface to connect external flash.

## 9.3 Digital peripherals

### 9.3.1 TIMER 0/1/2/3

Timer 0 and timer 1 are general-purpose 32-bit timers whereas timer 2 and timer 3 are general-purpose 16-bit timers. Both have a programmable 10-bit prescaler. The prescaler source is a system clock, 32 kHz clock or an external clock input.

The timers have the following functions:

- Input capture function
- Compare function
- PWM output

The timers generate maskable interrupts in the event of overflow, compare and capture. They are used to trigger MCU or ADC conversions.

### 9.3.2 Real-Time Clock (RTC)

A 32 kHz clock runs the RTC, which provides real time with calibration. It supports the following functions:

- Time and date configuration on the fly
- One second interrupt generation, interrupt can be enabled or disabled through software
- Input capture function with programmable noise canceler

### 9.3.3 WatchDog Timer (WDT)

The WatchDog Timer (WDT) is a 16-bit timer clocked by a 32 kHz clock. It is used as a recovery method in situations where the CPU may be subjected to a software upset. The WDT resets the system when the software fails to clear the WDT within the selected time interval. The WDT is configured either as a watchdog timer or as an interval timer for general-purpose use. If WDT is configured as an interval timer, it can be used to generate interrupts at selected time intervals. The maximum time-out interval is 1.5 days.

### 9.3.4 Sleep timer

The sleep timer is a 32-bit timer running at 32 kHz clock rate. It is in always-on power domain, used to set the interval for system to exit sleep mode and wake up MCU.

### 9.3.5 PWM

The PWM provides two-channel PWM waveforms with programmable period and duty cycle. It has two 8-bit auto reload down counter and programmable 10-bit prescaler for both channels. It supports the functions mentioned below:

- Predictable PWM initial output state
- Buffered compare register and polarity register to ensure correct PWM output
- Programmable overflow interrupt generation

### 9.3.6 DMA

The DMA controller is used to relieve the MCU of handling data transfer operations, leading to high performance and efficiency. It has a single DMA channel to support fixed and undefined length transfer. The source address and the destination address are programmable. It can be aborted immediately in a transfer process by configuring ABORT register, and a DMA done interrupt is generated meanwhile.

### 9.3.7 Random number generator

QN902x integrates a random number generator for security purpose.

### 9.3.8 AES coprocessor

The Advanced Encryption Standard (AES) coprocessor allows encryption/decryption to be performed with minimal CPU usage. The coprocessor supports 128-bit key and DMA transfer trigger capability.

## 9.4 Communication interfaces

### 9.4.1 UART 0/1

UART 0 and UART 1 have identical functions and include the following features:

- 8-bit payload mode: 8-bit data without parity
- 9-bit payload mode: 8-bit data plus parity
- The parity in 9-bit mode is odd or even configurable
- Configurable start bit and stop bit levels
- Configurable LSB first or MSB first data transfer
- Parity and framing error status
- Configurable hardware flow control
- Support overrun
- Flexible baud rate: 1.2/2.4/4.8/9.6/14.4/19.2/28.8/38.4/57.6/76.8/115.2/230.4 kBd

### 9.4.2 SPI 0/1

SPI 0 and SPI 1 have identical functions and includes the following features:

- Master/slave mode configurable
- 4-wire or 3-wire configurable
- Clock speed configurable for master mode (divided from AHB clock)
- 4 MHz maximum clock speed in slave mode when AHB clock is 32 MHz
- 16 MHz maximum clock speed in master mode when AHB clock is 32 MHz
- Configurable clock polarity and phase
- Configurable LSB or MSB first transfer

### 9.4.3 I<sup>2</sup>C-bus

The I<sup>2</sup>C-bus module provides an interface between the device and I<sup>2</sup>C-bus compatible devices connected by a 2-wire serial I<sup>2</sup>C-bus. The I<sup>2</sup>C-bus module features include:

- Compliance with the I<sup>2</sup>C-bus specification v2.1
- 7-bit device addressing modes
- Standard mode up to 100 kbit/s and fast mode up to 400 kbit/s support
- Supports master arbitration in master mode
- Supports line stretch in slave mode

## 9.5 Radio and analog peripherals

### 9.5.1 RF transceiver

QN902x radio transceiver is compliant with volume 6, part A: physical layer specification for Bluetooth LE. The transceiver requires a 32 MHz or a 16 MHz crystal to provide reference frequency. It also requires a matching network to match an antenna connected to the receiver/transmitter pins.

### 9.5.2 On-chip oscillators

QN902x includes three integrated oscillators:

- HFXO: Low-power high frequency crystal oscillator supporting 32 MHz or 16 MHz external crystal
- LFXO: Ultra low power 32.768 kHz crystal oscillator
- LFRCO: Ultra low power 32 kHz RC oscillator with  $\pm 250 \times 10^{-6}$  frequency accuracy after calibration

The high frequency crystal oscillator (HFXO) provides the reference frequency for radio transceiver. The low frequency 32.768 kHz oscillators provide the protocol timing. The low-frequency clock can also be obtained from a 32.768 kHz external clock source. For HFXO, the external capacitance is integrated to reduce the BOM cost. Software is used to adjust the capacitance.

### 9.5.3 DC-to-DC converter

QN902x includes highly efficient integrated regulators to generate all the internal supply voltages from a single external supply voltage. Optional integrated DC-to-DC down-converter is used to reduce the current consumption by 30 %. It is useful for applications using battery technologies with higher nominal cell voltages.

### 9.5.4 General-purpose ADC

QN902x integrates a general-purpose 8-bit or 10-bit SAR ADC, with a sampling rate of up to 50 kilosample per second. It includes an analog multiplexer with up to four external input channels. Conversion results can be moved to memory through DMA.

The main features of the ADC are as follows:

- Four single-ended input channels, or two differential channels
- Reference voltage selectable as internal or external signal-ended
- Interrupt request generation
- DMA triggers at the end of conversions
- Window compare function
- Battery measurement capability

When using internal reference voltage, it is calibrated to achieve high resolution.

The ADC operates in the following three modes:

- Signal conversion mode
- Continuous conversion mode
- Scan mode (automatic switching among external inputs)

### 9.5.5 Analog comparator

The analog comparator is used to compare the voltage of two analog inputs and has a digital output to indicate the higher input voltage. The positive input is always from the external pin. The negative input can be either one of the selectable internal references or from an external pin.

The analog comparator features low-power operation. The comparison result is used as an interrupt source to wake up the system from SLEEP mode.

### 9.5.6 Battery monitor

A battery monitor is integrated by connecting supply voltage ( $V_{DD} / 4$ ) to the ADC input. It uses the internal regulated reference for conversion.

## 10. Limiting values

**Table 5. Limiting values**

*In accordance with the Absolute Maximum Rating System (IEC 60134).*

Symbol	Parameter	Conditions	Min	Max	Unit
V <sub>CC</sub>	supply voltage	V <sub>CC</sub> to GND	-0.3	+5.0	V
V <sub>DD</sub>	supply voltage	V <sub>DD</sub> to GND	-0.3	+5.0	V
T <sub>stg</sub>	storage temperature		-55	+150	°C
V <sub>ESD</sub>	electrostatic discharge voltage	human body model			
		RFN, RFP	-	1.5	kV
		other pins	-	2	kV
		machine model			
		RFN, RFP	-	100	V
		other pins	-	200	V
		charged-device model			
		all pins	-	1	kV

## 11. Recommended operating conditions

**Table 6. Operating conditions**

Symbol	Parameter	Conditions	Min	Typ	Max	Unit
V <sub>CC</sub>	supply voltage	relative to GND				
		QN9020/1	2.4	3.0	3.6	V
		QN9022	1.8	3.0	3.6	V
V <sub>DD</sub>	supply voltage	relative to GND				
		QN9020/1	1.8	3.0	3.6	V
		QN9022	1.8	3.0	3.6	V
T <sub>amb</sub>	ambient temperature		-40	+25	+85	°C

## 12. Characteristics

### 12.1 DC characteristics

**Table 7. DC characteristics**

Typical values are  $T_{amb} = 25\text{ °C}$  and  $V_{CC} / V_{DD} = 3\text{ V}$ .

Symbol	Parameter	Conditions	Min	Typ	Max	Unit
I <sub>CC</sub>	supply current	deep sleep mode <a href="#">[1][2]</a>	-	2	-	μA
		sleep mode <a href="#">[1][3]</a>	-	3	-	μA
		idle mode without DC-to-DC converter <a href="#">[1][4]</a>	-	0.84	-	mA
		MCU @8 MHz without DC-to-DC converter <a href="#">[1][5]</a>	-	1.35	-	mA
		RX mode without DC-to-DC converter <a href="#">[1][6]</a>	-	13.6	-	mA
		RX mode with DC-to-DC converter <a href="#">[1][7]</a>	-	9.25	-	mA
		TX mode @0 dBm TX power without DC-to-DC converter <a href="#">[1]</a>	-	13.3	-	mA
		TX mode @0 dBm TX power with DC-to-DC converter <a href="#">[1]</a>	-	8.8	-	mA
t <sub>startup</sub>	start-up time	RSTN pin remains at LOW level	50	-	-	μs
<b>Interface</b> <a href="#">[8]</a>						
V <sub>OH</sub>	HIGH-level output voltage		$0.9 \times V_{CC}$	-	-	V
V <sub>OL</sub>	LOW-level output voltage		-	-	$0.1 \times V_{CC}$	V
V <sub>IH</sub>	HIGH-level input voltage		$0.7 \times V_{CC}$	-	-	V
V <sub>IL</sub>	LOW-level input voltage		-	-	$0.3 \times V_{CC}$	V

- [1] Supply current for both analog and digital modes.  
 [2] Deep sleep mode: digital regulator off, no clocks, POR, RAM/register control retained.  
 [3] Sleep mode: digital regulator off, 32 kHz RC oscillator on, POR, sleep timer on, and RAM/register content retained.  
 [4] Idle: 16 MHz oscillator on, no radio or peripherals, 8 MHz system clock and MCU idle (no code execution).  
 [5] MCU@8 MHz: MCU running at 8 MHz RC oscillator, no radio peripherals.  
 [6] RX sensitivity is -95 dBm when DC-to-DC is disabled.  
 [7] RX sensitivity is -93 dBm when DC-to-DC is enabled.  
 [8] Depend on I/O conditions.

**Table 8. 16/32 MHz crystal oscillator reference clock**

Symbol	Parameter	Conditions	Min	Typ	Max	Unit
f <sub>xtal</sub>	crystal frequency		-	16	-	MHz
			-	32	-	MHz
Δf <sub>xtal</sub>	crystal frequency accuracy		$-50 \times 10^{-6}$	-	$+50 \times 10^{-6}$	-

**Table 8.** 16/32 MHz crystal oscillator reference clock ...continued

Symbol	Parameter	Conditions	Min	Typ	Max	Unit
ESR	equivalent series resistance		-	-	50	$\Omega$
$C_L$	load capacitance		5	-	9	pF
$t_{startup}$	start-up time	16 MHz crystal oscillator [1]	-	-	0.7	ms
		32 MHz crystal oscillator [1]	-	-	0.4	ms

[1] Guaranteed by design.

**Table 9.** 32 kHz crystal oscillator reference clock

Typical values are  $T_{amb} = 25\text{ }^\circ\text{C}$  and  $V_{CC} / V_{DD} = 3\text{ V}$ .

Symbol	Parameter	Conditions	Min	Typ	Max	Unit
$f_{xtal}$	crystal frequency		-	32.768	-	kHz
$\Delta f_{xtal}$	crystal frequency accuracy		-	$250 \times 10^{-6}$	-	-
ESR	equivalent series resistance		-	-	100	k $\Omega$
$C_L$	load capacitance		-	12	-	pF
$t_{startup}$	start-up time		-	1	-	s

**Table 10.** 32 kHz RC oscillator reference clock

Typical values are  $T_{amb} = 25\text{ }^\circ\text{C}$  and  $V_{CC} / V_{DD} = 3\text{ V}$ .

Symbol	Parameter	Conditions	Min	Typ	Max	Unit
$f_{osc}$	oscillator frequency		-	32	-	kHz
$f_{osc(acc)}$	oscillator frequency accuracy		-	$500 \times 10^{-6}$	-	-
TC	temperature coefficient		-	0.04	-	%/ $^\circ\text{C}$
$\Delta f_{osc} / \Delta V_{CC}$	oscillator frequency variation with supply voltage		-	3	-	%/V
$t_{cal}$	calibration time		-	-	1	ms

**Table 11.** RF receiver characteristics

Typical values are  $T_{amb} = 25\text{ }^\circ\text{C}$ ;  $V_{CC} / V_{DD} = 3\text{ V}$ ;  $f_c = 2440\text{ MHz}$ ;  $BER < 0.1\%$ .

Symbol	Parameter	Conditions	Min	Typ	Max	Unit
$S_{RX}$	RX sensitivity	high performance mode	-	-95	-	dBm
		low power mode with DC-to-DC converter	-	-93	-	dBm
$P_{I(max)}$	maximum input power		-	0	-	dBm
C/I	carrier-to-interference ratio	co-channel	-	6	-	dB
		adjacent channel @ $\pm 1\text{ MHz}$	-	-1	-	dB
		$\alpha\lambda\tau\epsilon\rho\nu\epsilon\lambda \cong \pm 2\text{ MHz}$	-	-40	-	dB
$\alpha_{image}$	image rejection		-	-19	-	dB

**Table 11. RF receiver characteristics ...continued**

Typical values are  $T_{amb} = 25\text{ }^{\circ}\text{C}$ ;  $V_{CC} / V_{DD} = 3\text{ V}$ ;  $f_c = 2440\text{ MHz}$ ;  $BER < 0.1\%$ .

Symbol	Parameter	Conditions	Min	Typ	Max	Unit
$\alpha_{\text{sup(oob)}}$	out-of-band suppression	30 MHz to 2000 MHz	-18	-	-	dBm
		2003 MHz to 2399 MHz	-18	-	-	dBm
		2484 MHz to 2997 MHz	-18	-	-	dBm
		3 GHz to 12.75 GHz	-18	-	-	dBm

**Table 12. RF transmitter characteristics**

Typical values are  $T_{amb} = 25\text{ }^{\circ}\text{C}$ ;  $V_{CC} / V_{DD} = 3\text{ V}$ ;  $f_c = 2440\text{ MHz}$ .

Symbol	Parameter	Conditions	Min	Typ	Max	Unit	
$f_{o(\text{RF})}$	RF output frequency		2400	-	2483.5	MHz	
$\alpha_{\text{CS}}$	channel separation		-	2	-	MHz	
$P_o$	output power	TX power without DC-to-DC converter	-20	-	+4	dBm	
		TX power with DC-to-DC converter	-20	-	+4	dBm	
$P_{o(\text{RF})\text{step}}$	RF output power step		-	2	-	dB	
$P_{o(\text{acc})}$	TX power accuracy		-2	-	+2	dB	
$I_{\text{CC}(\text{TX})}$	transmitter supply current	without DC-to-DC					
		4 dBm	-	17.6	-	mA	
		0 dBm	-	13.3	-	mA	
		-4 dBm	-	10.5	-	mA	
		-8 dBm	-	8.3	-	mA	
		-20 dBm	-	6.1	-	mA	
		with DC-to-DC					
		0 dBm	-	8.8	-	mA	
		-4 dBm	-	6.9	-	mA	
		-8 dBm	-	5.9	-	mA	
		-20 dBm	-	4.3	-	mA	

**Table 13. RSSI characteristics**

Typical values are  $T_{amb} = 25\text{ }^{\circ}\text{C}$  and  $V_{CC} / V_{DD} = 3\text{ V}$ .

Symbol	Parameter	Conditions	Min	Typ	Max	Unit
$\alpha_{\text{RSSI}(\text{range})}$	RSSI range		-90	-	-30	dBm
$\alpha_{\text{RSSI}(\text{acc})}$	RSSI accuracy		-4	-	+4	dB
$\alpha_{\text{RSSI}(\text{res})}$	RSSI resolution		-	1	-	dB

**Table 14. ADC characteristics**

Typical values are  $T_{amb} = 25\text{ }^{\circ}\text{C}$  and  $V_{CC} / V_{DD} = 3\text{ V}$ , with differential ADC input signal.

Symbol	Parameter	Conditions	Min	Typ	Max	Unit
$V_{I(\text{ADC})}$	ADC input voltage	single-ended mode	0	-	$V_{\text{ref}}$	V
		differential input mode	$-V_{\text{ref}}$	-	$+V_{\text{ref}}$	V
ENOB	effective number of bits	10-bit	-	9.3	-	bits
S/N	signal-to-noise ratio	10-bit	-	59.3	-	dB

**Table 14. ADC characteristics ...continued**

Typical values are  $T_{amb} = 25\text{ °C}$  and  $V_{CC} / V_{DD} = 3\text{ V}$ , with differential ADC input signal.

Symbol	Parameter	Conditions	Min	Typ	Max	Unit
SFDR	spurious-free dynamic range	10-bit	-	65.2	-	dB
THD	total harmonic distortion	10-bit	-	-63	-	dB
DNL	differential non-linearity	10-bit	-1	+0.6	+2	LSB
INL	integral non-linearity	10-bit	-2	+0.88	+3	LSB
$t_{c(ADC)}$	ADC conversion time	10-bit	-	18	-	$\mu\text{s}$
$E_G$	gain error	10-bit	-	4	10	LSB
$E_O$	offset error	10-bit	-	-	2	LSB
$I_{CC(int)ADC}$	ADC internal supply current	@1 MHz ADC clock				
		ADC	-	50	65	$\mu\text{A}$
		buffer	-	140	180	$\mu\text{A}$
		PGA	-	90	120	$\mu\text{A}$

**Table 15. Battery monitor characteristics**

Typical values are  $T_{amb} = 25\text{ °C}$  and  $V_{CC} / V_{DD} = 3\text{ V}$ .

Symbol	Parameter	Conditions	Min	Typ	Max	Unit
$V_{mon(bat)}$	battery monitor voltage	QN9020/1	2.4	-	3.6	V
		QN9022	1.8	-	3.6	V
$V_{mon(bat)acc}$	battery monitor accuracy		-	0.2	-	mV

**Table 16. Analog comparator characteristics**

Typical values are  $T_{amb} = 25\text{ °C}$  and  $V_{CC} / V_{DD} = 3\text{ V}$ .

Symbol	Parameter	Conditions	Min	Typ	Max	Unit
$V_i$	input voltage		0	-	$V_{DD}$	V
$I_{CC(int)A}$	analog internal supply current		-	0.3	-	$\mu\text{A}$
$V_{hys}$	hysteresis		-	40	-	mV

### 13. Application information

#### 13.1 Schematic for QN9020 with DC-to-DC converter

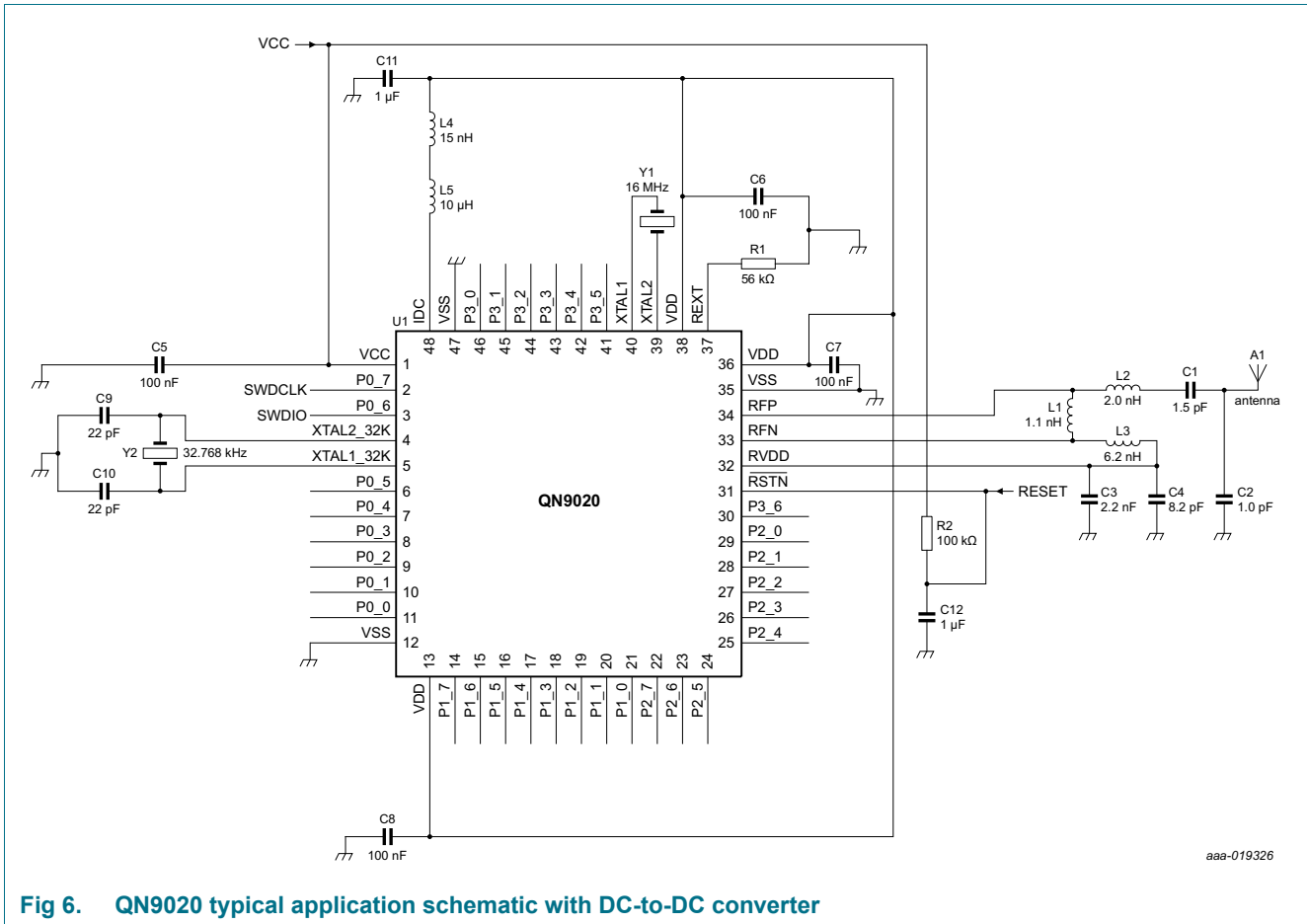

Fig 6. QN9020 typical application schematic with DC-to-DC converter

aaa-019326

13.2 Schematic for QN9020 without DC-to-DC converter

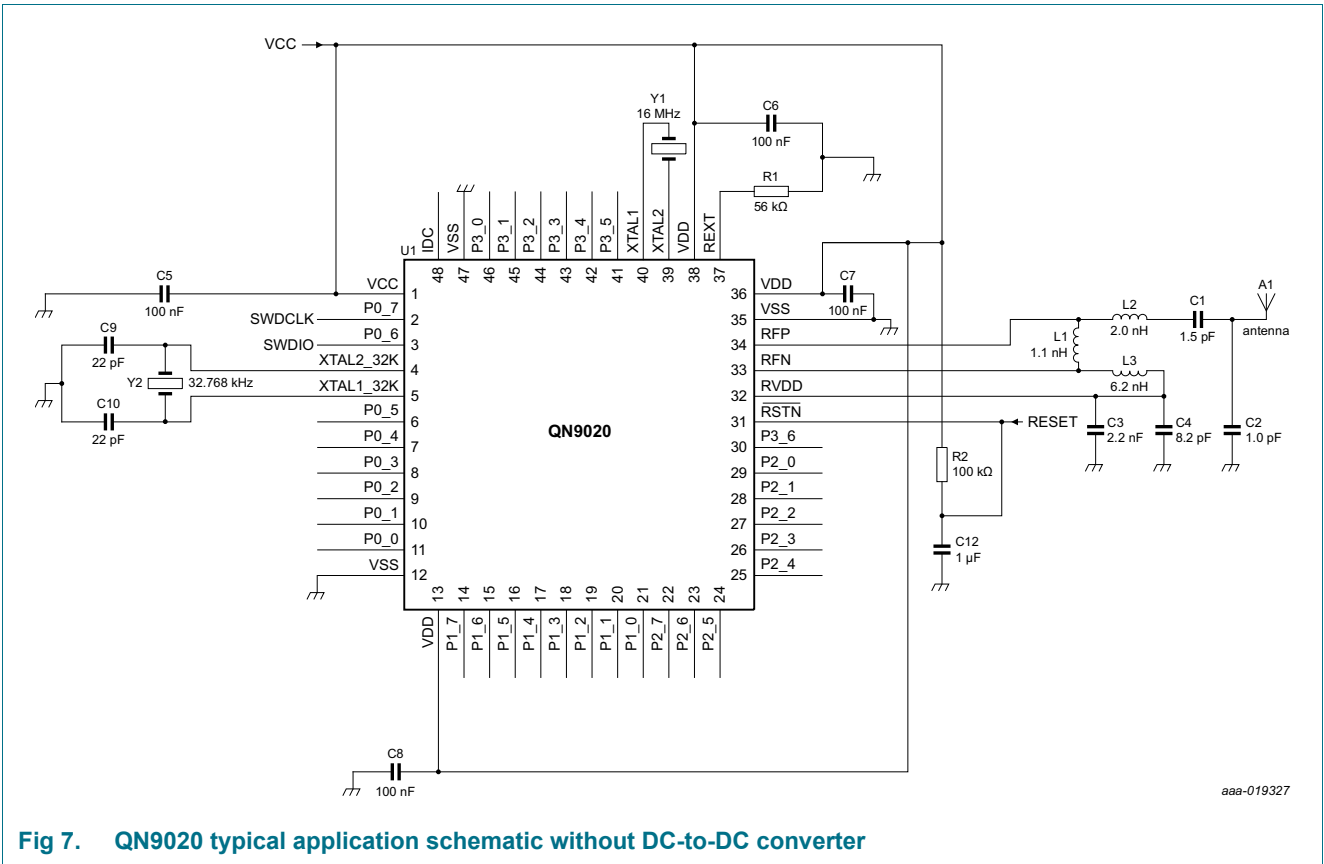
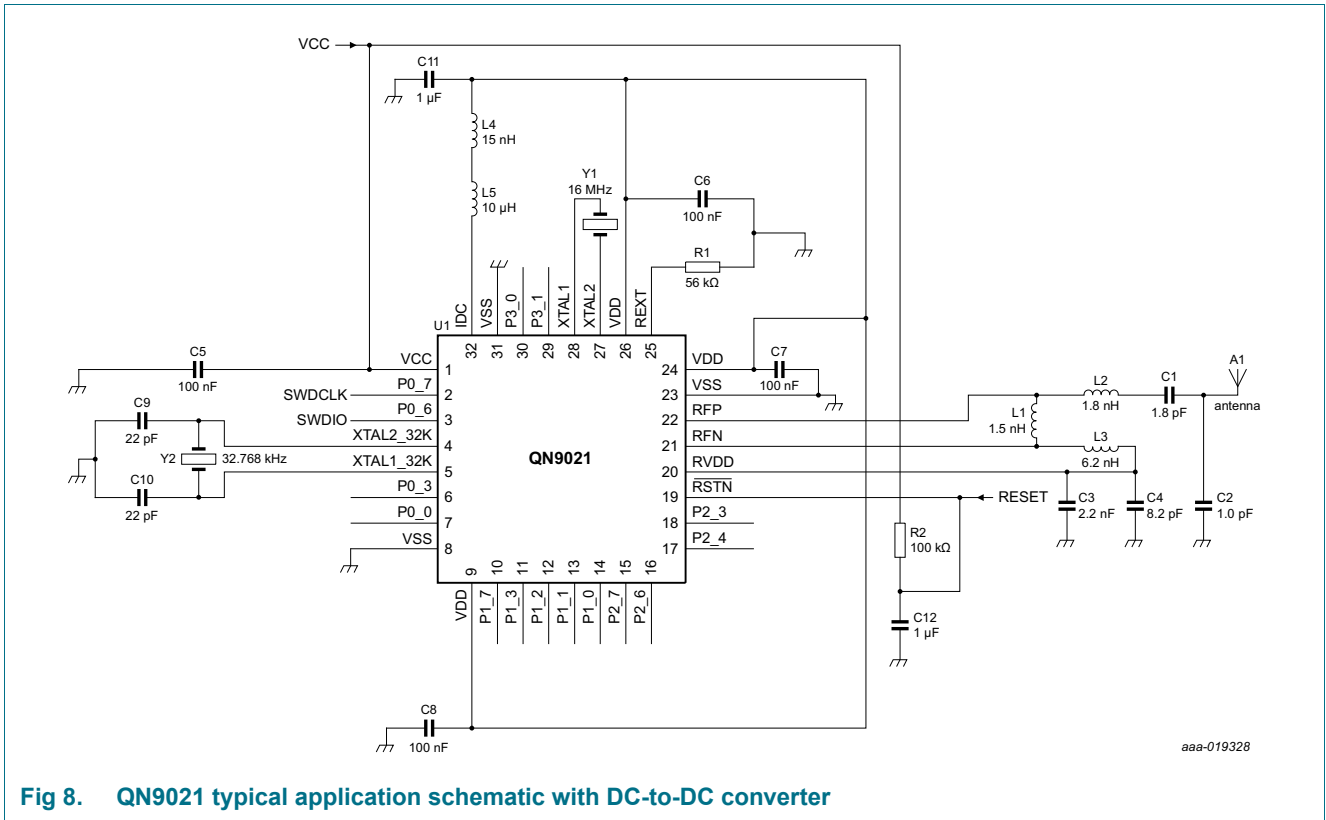

Fig 7. QN9020 typical application schematic without DC-to-DC converter

aaa-019327

13.3 Schematic for QN9021 with DC-to-DC converter



aaa-019328

Fig 8. QN9021 typical application schematic with DC-to-DC converter

13.4 Schematic for QN9021 without DC-to-DC converter

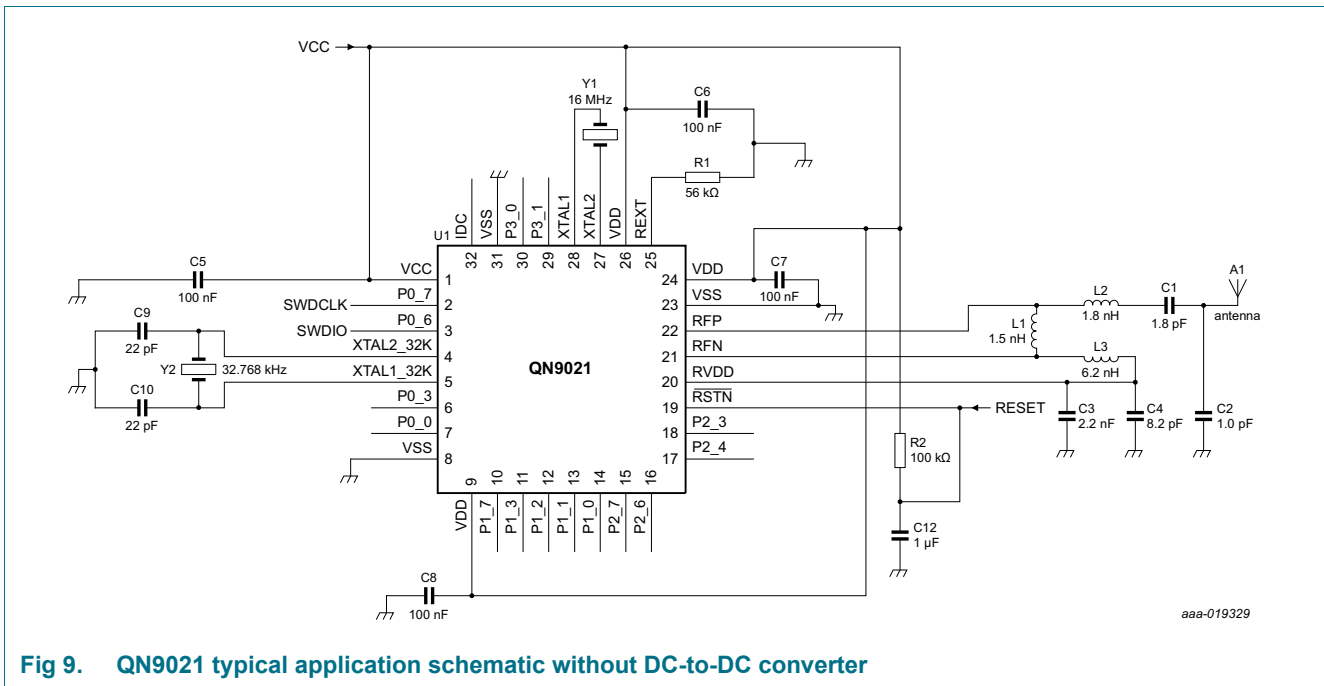
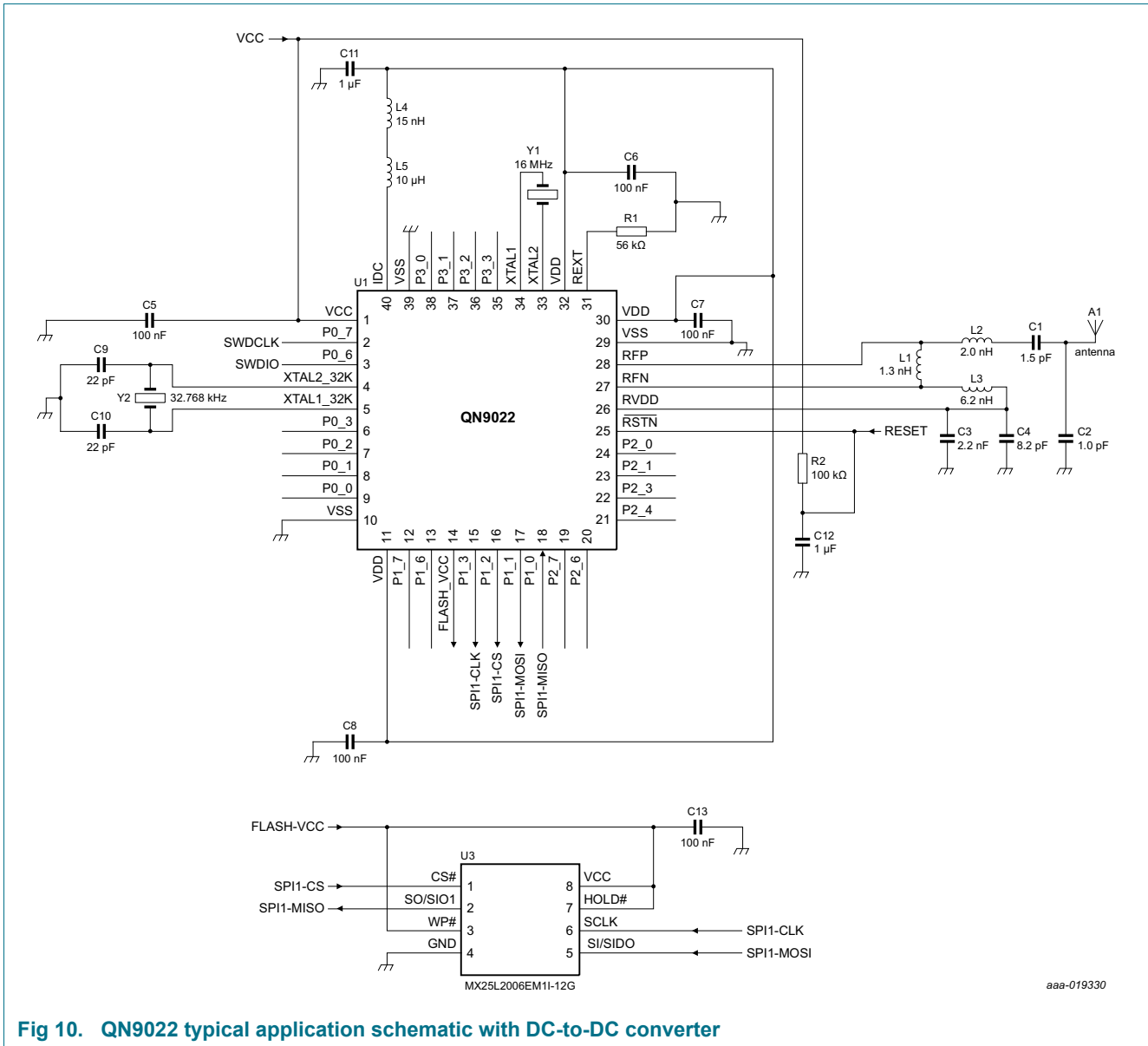

Fig 9. QN9021 typical application schematic without DC-to-DC converter

13.5 Schematic for QN9022 with DC-to-DC converter



aaa-019330

Fig 10. QN9022 typical application schematic with DC-to-DC converter



## 13.7 QN902x external component list

Table 17. External component list

Component	Description	Value
C1	capacitor for RF matching network	1.5 pF (QN9020/2), 1.8 pF (QN9021)
C2	capacitor for RF matching network	1.0 pF
C3	capacitor for RF matching network	2.2 nF
C4	capacitor for RF matching network	8.2 pF
C5, C6, C7, C8	supply decoupling capacitors	100 nF, X5R, $\pm 10\%$ , 6.3 V, 0402
C9, C10	crystal loading capacitors	22 pF, NP0, $\pm 5\%$ , 25 V, 0402
C11	supply decoupling capacitor	1 $\mu$ F, NP0, $\pm 5\%$ , 6.3 V, 0402
C12	capacitor used for reset	1 $\mu$ F, NP0, $\pm 5\%$ , 6.3 V, 0402
C13	supply decoupling capacitor	100 nF, X5R, $\pm 10\%$ , 6.3 V, 0402
L1	inductor for RF matching network	1.1 nH (QN9020), 1.5 nH (QN9021), 1.3 nH (QN9022)
L2	inductor for RF matching network	2.0 nH (QN9020/2), 1.8 nH (QN9021)
L3	inductor for RF matching network	6.2 nH
L4	chip inductor for DC-to-DC	15 nH
L5	chip inductor for DC-to-DC	10 $\mu$ H
R1	resistor used for current reference	56 k $\Omega$ , $\pm 1\%$ , 0402
R2	resistor used for reset	100 k $\Omega$ , $\pm 1\%$ , 0402

### 14. Package outline

HVQFN48: plastic thermal enhanced very thin quad flat package; no leads;  
48 terminals; body 6 x 6 x 0.85 mm

SOT778-4

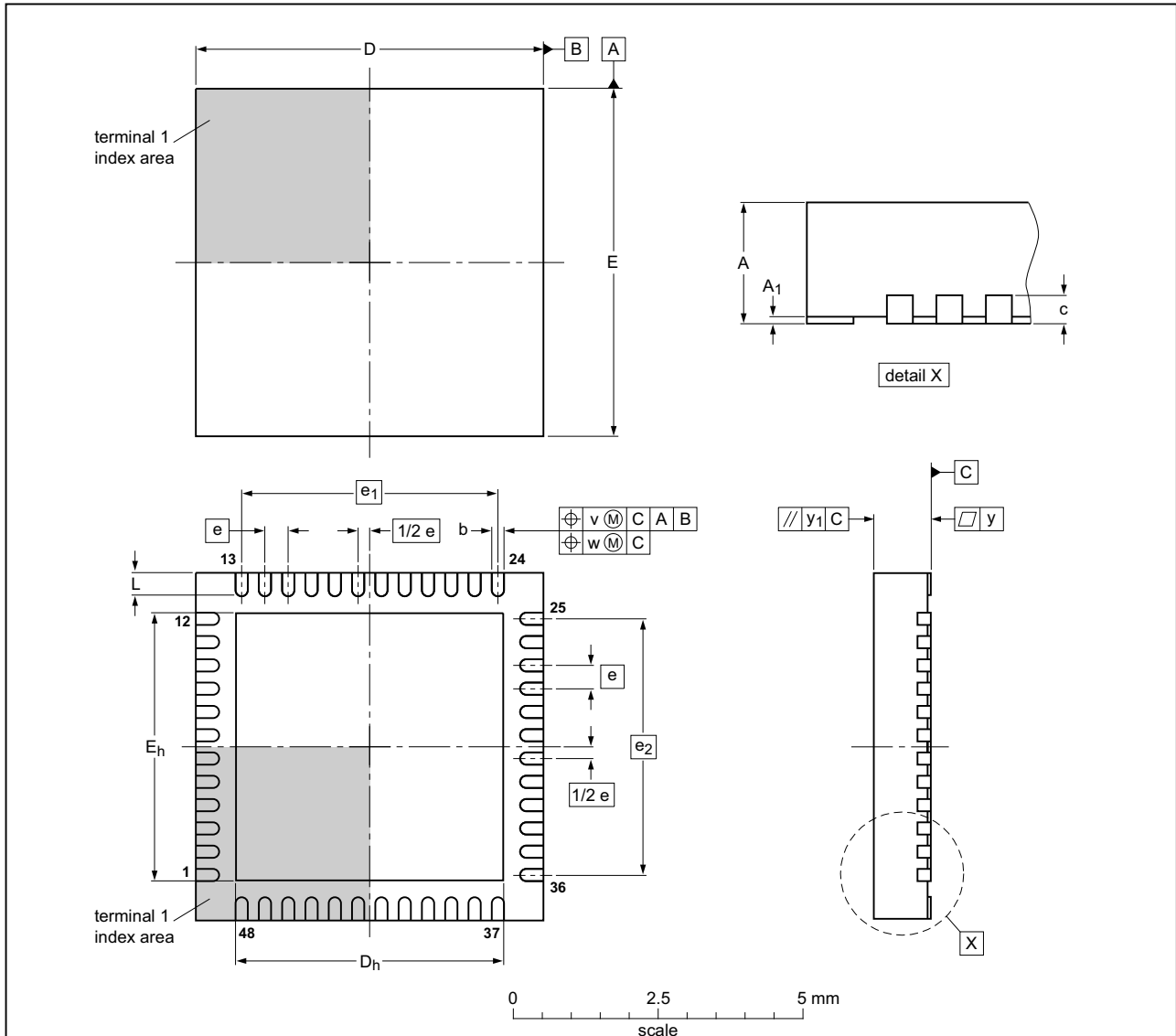

**DIMENSIONS** (mm are the original dimensions)

UNIT	A <sup>(1)</sup> max	A <sub>1</sub>	b	c	D <sup>(1)</sup>	D <sub>h</sub>	E <sup>(1)</sup>	E <sub>h</sub>	e	e <sub>1</sub>	e <sub>2</sub>	L	v	w	y	y <sub>1</sub>
mm	1	0.05 0.00	0.25 0.15	0.2	6.1 5.9	4.75 4.45	6.1 5.9	4.75 4.45	0.4	4.4	4.4	0.5 0.3	0.1	0.05	0.05	0.1

**Note**

1. Plastic or metal protrusions of 0.075 mm maximum per side are not included

OUTLINE VERSION	REFERENCES				EUROPEAN PROJECTION	ISSUE DATE
	IEC	JEDEC	JEITA			
SOT778-4	---	---	---			04-07-30 04-10-07

Fig 12. Package outline SOT778-4 (HVQFN48)

HVQFN32: plastic thermal enhanced very thin quad flat package; no leads;  
32 terminals; body 5 x 5 mm

SOT617-13

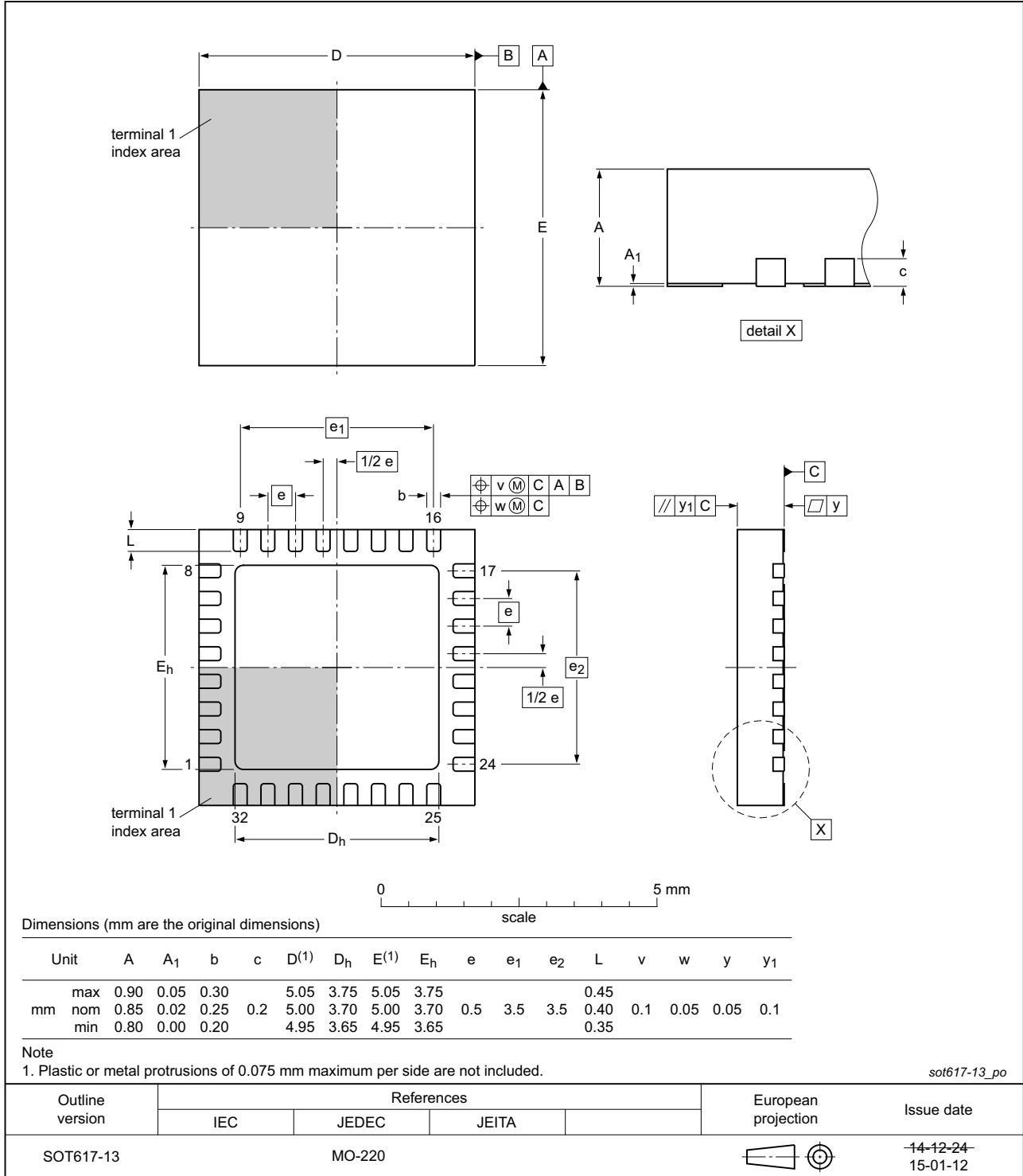

Fig 13. Package outline SOT617-13 (HVQFN32)

HVQFN40: plastic thermal enhanced very thin quad flat package; no leads;  
40 terminals; body 5 x 5 x 0.85 mm

SOT1369-2

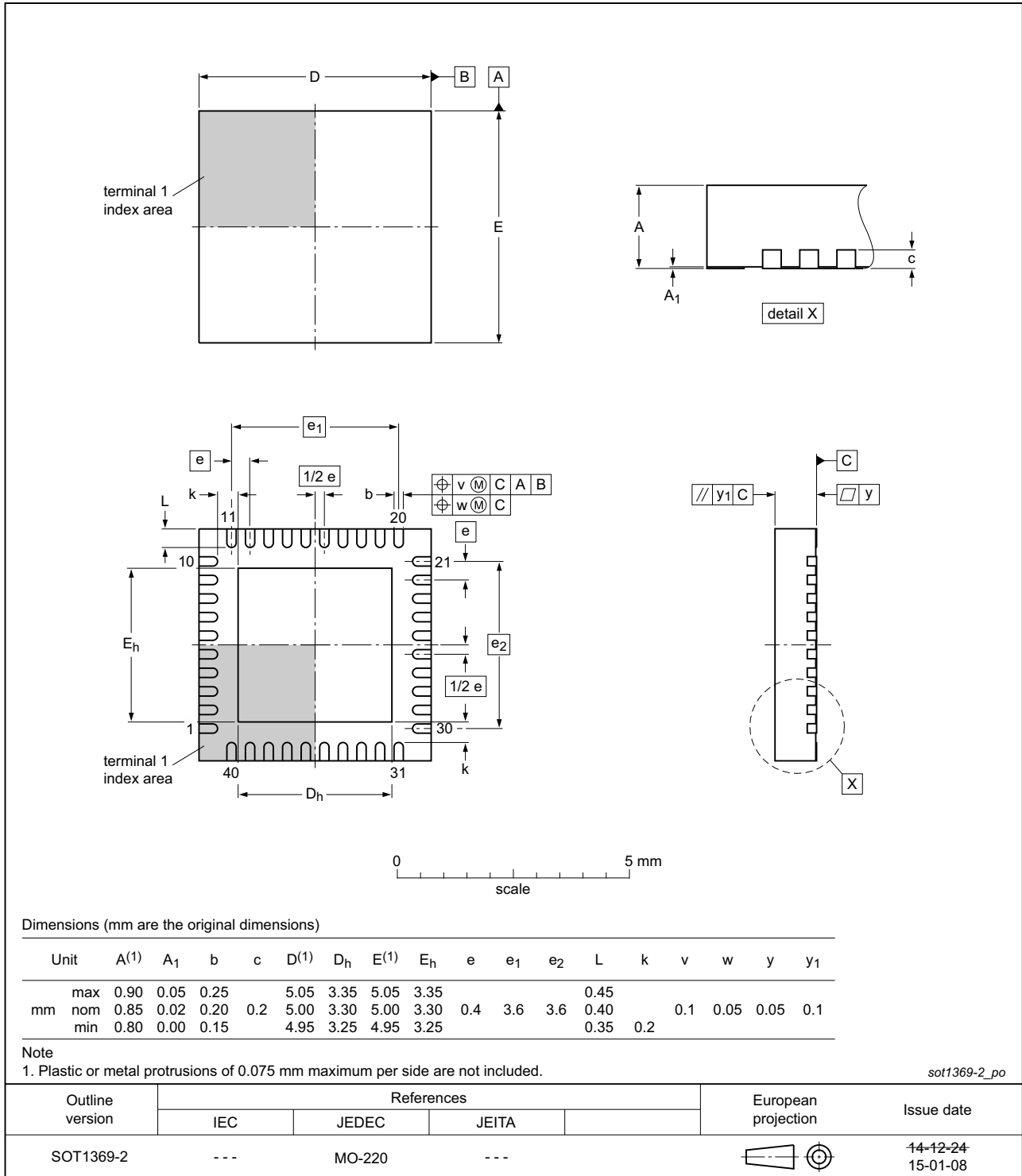

Fig 14. Package outline SOT1369-2 (HVQFN40)

## 15. Soldering of SMD packages

This text provides a very brief insight into a complex technology. A more in-depth account of soldering ICs can be found in Application Note *AN10365 "Surface mount reflow soldering description"*.

### 15.1 Introduction to soldering

Soldering is one of the most common methods through which packages are attached to Printed Circuit Boards (PCBs), to form electrical circuits. The soldered joint provides both the mechanical and the electrical connection. There is no single soldering method that is ideal for all IC packages. Wave soldering is often preferred when through-hole and Surface Mount Devices (SMDs) are mixed on one printed wiring board; however, it is not suitable for fine pitch SMDs. Reflow soldering is ideal for the small pitches and high densities that come with increased miniaturization.

### 15.2 Wave and reflow soldering

Wave soldering is a joining technology in which the joints are made by solder coming from a standing wave of liquid solder. The wave soldering process is suitable for the following:

- Through-hole components
- Leaded or leadless SMDs, which are glued to the surface of the printed circuit board

Not all SMDs can be wave soldered. Packages with solder balls, and some leadless packages which have solder lands underneath the body, cannot be wave soldered. Also, leaded SMDs with leads having a pitch smaller than ~0.6 mm cannot be wave soldered, due to an increased probability of bridging.

The reflow soldering process involves applying solder paste to a board, followed by component placement and exposure to a temperature profile. Leaded packages, packages with solder balls, and leadless packages are all reflow solderable.

Key characteristics in both wave and reflow soldering are:

- Board specifications, including the board finish, solder masks and vias
- Package footprints, including solder thieves and orientation
- The moisture sensitivity level of the packages
- Package placement
- Inspection and repair
- Lead-free soldering versus SnPb soldering

### 15.3 Wave soldering

Key characteristics in wave soldering are:

- Process issues, such as application of adhesive and flux, clinching of leads, board transport, the solder wave parameters, and the time during which components are exposed to the wave
- Solder bath specifications, including temperature and impurities

## 15.4 Reflow soldering

Key characteristics in reflow soldering are:

- Lead-free versus SnPb soldering; note that a lead-free reflow process usually leads to higher minimum peak temperatures (see [Figure 15](#)) than a SnPb process, thus reducing the process window
- Solder paste printing issues including smearing, release, and adjusting the process window for a mix of large and small components on one board
- Reflow temperature profile; this profile includes preheat, reflow (in which the board is heated to the peak temperature) and cooling down. It is imperative that the peak temperature is high enough for the solder to make reliable solder joints (a solder paste characteristic). In addition, the peak temperature must be low enough that the packages and/or boards are not damaged. The peak temperature of the package depends on package thickness and volume and is classified in accordance with [Table 18](#) and [19](#)

**Table 18. SnPb eutectic process (from J-STD-020D)**

Package thickness (mm)	Package reflow temperature (°C)	
	Volume (mm <sup>3</sup> )	
	< 350	≥ 350
< 2.5	235	220
≥ 2.5	220	220

**Table 19. Lead-free process (from J-STD-020D)**

Package thickness (mm)	Package reflow temperature (°C)		
	Volume (mm <sup>3</sup> )		
	< 350	350 to 2000	> 2000
< 1.6	260	260	260
1.6 to 2.5	260	250	245
> 2.5	250	245	245

Moisture sensitivity precautions, as indicated on the packing, must be respected at all times.

Studies have shown that small packages reach higher temperatures during reflow soldering, see [Figure 15](#).

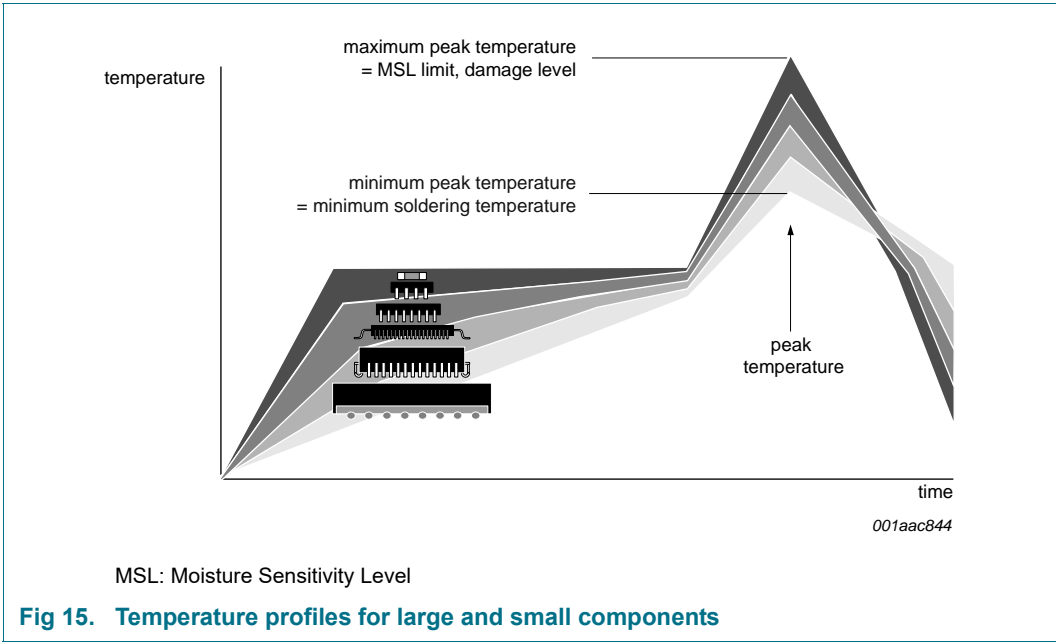

For further information on temperature profiles, refer to Application Note AN10365 “Surface mount reflow soldering description”.

## 16. Abbreviations

Table 20. Abbreviations

Acronym	Description
ADC	Analog-to-Digital Converter
AES	Advanced Encryption Standard
AHB	AMBA High-performance Bus
BER	Bit Error Rate
DTM	Direct Test Mode
EEPROM	Electrically Erasable Programmable Read Only Memory
GFSK	Gaussian Frequency-Shift Keying
GPIO	General Purpose Input Output
LDO	Low DropOut
LE	Low Energy
LSB	Least Significant Bit
MCU	MicroController Unit
MSB	Most Significant Bit
PGA	Programmable Gain Amplifier
PWM	Pulse Width Modulation
RF	Radio Frequency
RSSI	Received Signal Strength Indicator
RTC	Real-Time Clock
SAR	Successive Approximation Register
S/N	Signal-to-Noise ratio
SoC	System-on-Chip
SPI	Serial Peripheral Interface
SWD	Serial Wire Debug
UART	Universal Asynchronous Receiver Transmitter

## 17. Revision history

Table 21. Revision history

Document ID	Release date	Data sheet status	Change notice	Supersedes
QN902x v.2.7	20181121	Product data sheet		
Modifications	<ul style="list-style-type: none"> <li>Changes the maximum value of <math>P_o</math> in <a href="#">Table 12 “RF transmitter characteristics” on page 21</a></li> </ul>			
QN902x v.2.6	20181119	Product data sheet		
Modifications	<ul style="list-style-type: none"> <li>Changed the description of alternate function P2_6 in <a href="#">Table 3 “Pin description” on page 6</a></li> <li>Changed the description of alternate function Fast Boot in <a href="#">Table 3 “Pin description” on page 6</a></li> </ul>			
QN902x v.2.5	20180418	Product data sheet		
Modifications	<ul style="list-style-type: none"> <li>Added alternate function Fast Boot in <a href="#">Table 3 “Pin description” on page 6</a></li> </ul>			
QN902x v.2.4	20170116	Product data sheet	-	QN902x v.2.3
Modifications:	<ul style="list-style-type: none"> <li>Minor update to VDD voltage for QN9020/1 <a href="#">Table 6 “Operating conditions” on page 17</a></li> </ul>			
QN902x v.2.3	20160905	Product data sheet	-	QN902x v.2.2
Modifications:	<ul style="list-style-type: none"> <li>Minor update to XTAL1 and XTAL2 in <a href="#">Table 3 “Pin description” on page 6</a></li> </ul>			
QN902x v.2.2	20160825	Product data sheet	-	QN902x v.2.1
Modifications:	<ul style="list-style-type: none"> <li>Minor update to <a href="#">Table 7 “DC characteristics” on page 18</a></li> </ul>			
QN902x v.2.1	20160414	Product data sheet	-	QN902x v.2
Modifications:	<ul style="list-style-type: none"> <li>GPIO pin information and package details for QN9020/1/2 updated</li> <li>Update to <a href="#">Table 7</a></li> </ul>			
QN902x v.2	20160314	Product data sheet	-	QN902x v.1
Modifications:	<ul style="list-style-type: none"> <li>Information about QN9022 is added to the data sheet</li> <li>Added RSSI characteristics Table 13</li> </ul>			
QN902x v.1	20150210	Product data sheet	-	-

## 18. Legal information

### 18.1 Data sheet status

Document status <sup>[1][2]</sup>	Product status <sup>[3]</sup>	Definition
Objective [short] data sheet	Development	This document contains data from the objective specification for product development.
Preliminary [short] data sheet	Qualification	This document contains data from the preliminary specification.
Product [short] data sheet	Production	This document contains the product specification.

[1] Please consult the most recently issued document before initiating or completing a design.

[2] The term 'short data sheet' is explained in section "Definitions".

[3] The product status of device(s) described in this document may have changed since this document was published and may differ in case of multiple devices. The latest product status information is available on the Internet at URL <http://www.nxp.com>.

### 18.2 Definitions

**Draft** — The document is a draft version only. The content is still under internal review and subject to formal approval, which may result in modifications or additions. NXP Semiconductors does not give any representations or warranties as to the accuracy or completeness of information included herein and shall have no liability for the consequences of use of such information.

**Short data sheet** — A short data sheet is an extract from a full data sheet with the same product type number(s) and title. A short data sheet is intended for quick reference only and should not be relied upon to contain detailed and full information. For detailed and full information see the relevant full data sheet, which is available on request via the local NXP Semiconductors sales office. In case of any inconsistency or conflict with the short data sheet, the full data sheet shall prevail.

**Product specification** — The information and data provided in a Product data sheet shall define the specification of the product as agreed between NXP Semiconductors and its customer, unless NXP Semiconductors and customer have explicitly agreed otherwise in writing. In no event however, shall an agreement be valid in which the NXP Semiconductors product is deemed to offer functions and qualities beyond those described in the Product data sheet.

### 18.3 Disclaimers

**Limited warranty and liability** — Information in this document is believed to be accurate and reliable. However, NXP Semiconductors does not give any representations or warranties, expressed or implied, as to the accuracy or completeness of such information and shall have no liability for the consequences of use of such information. NXP Semiconductors takes no responsibility for the content in this document if provided by an information source outside of NXP Semiconductors.

In no event shall NXP Semiconductors be liable for any indirect, incidental, punitive, special or consequential damages (including - without limitation - lost profits, lost savings, business interruption, costs related to the removal or replacement of any products or rework charges) whether or not such damages are based on tort (including negligence), warranty, breach of contract or any other legal theory.

Notwithstanding any damages that customer might incur for any reason whatsoever, NXP Semiconductors' aggregate and cumulative liability towards customer for the products described herein shall be limited in accordance with the *Terms and conditions of commercial sale* of NXP Semiconductors.

**Right to make changes** — NXP Semiconductors reserves the right to make changes to information published in this document, including without limitation specifications and product descriptions, at any time and without notice. This document supersedes and replaces all information supplied prior to the publication hereof.

**Suitability for use** — NXP Semiconductors products are not designed, authorized or warranted to be suitable for use in life support, life-critical or safety-critical systems or equipment, nor in applications where failure or malfunction of an NXP Semiconductors product can reasonably be expected to result in personal injury, death or severe property or environmental damage. NXP Semiconductors and its suppliers accept no liability for inclusion and/or use of NXP Semiconductors products in such equipment or applications and therefore such inclusion and/or use is at the customer's own risk.

**Applications** — Applications that are described herein for any of these products are for illustrative purposes only. NXP Semiconductors makes no representation or warranty that such applications will be suitable for the specified use without further testing or modification.

Customers are responsible for the design and operation of their applications and products using NXP Semiconductors products, and NXP Semiconductors accepts no liability for any assistance with applications or customer product design. It is customer's sole responsibility to determine whether the NXP Semiconductors product is suitable and fit for the customer's applications and products planned, as well as for the planned application and use of customer's third party customer(s). Customers should provide appropriate design and operating safeguards to minimize the risks associated with their applications and products.

NXP Semiconductors does not accept any liability related to any default, damage, costs or problem which is based on any weakness or default in the customer's applications or products, or the application or use by customer's third party customer(s). Customer is responsible for doing all necessary testing for the customer's applications and products using NXP Semiconductors products in order to avoid a default of the applications and the products or of the application or use by customer's third party customer(s). NXP does not accept any liability in this respect.

**Limiting values** — Stress above one or more limiting values (as defined in the Absolute Maximum Ratings System of IEC 60134) will cause permanent damage to the device. Limiting values are stress ratings only and (proper) operation of the device at these or any other conditions above those given in the Recommended operating conditions section (if present) or the Characteristics sections of this document is not warranted. Constant or repeated exposure to limiting values will permanently and irreversibly affect the quality and reliability of the device.

**Terms and conditions of commercial sale** — NXP Semiconductors products are sold subject to the general terms and conditions of commercial sale, as published at <http://www.nxp.com/profile/terms>, unless otherwise agreed in a valid written individual agreement. In case an individual agreement is concluded only the terms and conditions of the respective agreement shall apply. NXP Semiconductors hereby expressly objects to applying the customer's general terms and conditions with regard to the purchase of NXP Semiconductors products by customer.

**No offer to sell or license** — Nothing in this document may be interpreted or construed as an offer to sell products that is open for acceptance or the grant, conveyance or implication of any license under any copyrights, patents or other industrial or intellectual property rights.

**Export control** — This document as well as the item(s) described herein may be subject to export control regulations. Export might require a prior authorization from competent authorities.

**Non-automotive qualified products** — Unless this data sheet expressly states that this specific NXP Semiconductors product is automotive qualified, the product is not suitable for automotive use. It is neither qualified nor tested in accordance with automotive testing or application requirements. NXP Semiconductors accepts no liability for inclusion and/or use of non-automotive qualified products in automotive equipment or applications.

In the event that customer uses the product for design-in and use in automotive applications to automotive specifications and standards, customer (a) shall use the product without NXP Semiconductors' warranty of the product for such automotive applications, use and specifications, and (b)

whenever customer uses the product for automotive applications beyond NXP Semiconductors' specifications such use shall be solely at customer's own risk, and (c) customer fully indemnifies NXP Semiconductors for any liability, damages or failed product claims resulting from customer design and use of the product for automotive applications beyond NXP Semiconductors' standard warranty and NXP Semiconductors' product specifications.

## 18.4 Trademarks

Notice: All referenced brands, product names, service names and trademarks are the property of their respective owners.

**I<sup>2</sup>C-bus** — logo is a trademark of NXP Semiconductors N.V.

## 19. Contact information

For more information, please visit: <http://www.nxp.com>

For sales office addresses, please send an email to: [salesaddresses@nxp.com](mailto:salesaddresses@nxp.com)

## 20. Tables

---

Table 1.	Supported profiles and services . . . . .	3
Table 2.	Ordering information . . . . .	3
Table 3.	Pin description . . . . .	6
Table 4.	Power matrix . . . . .	12
Table 5.	Limiting values . . . . .	17
Table 6.	Operating conditions . . . . .	17
Table 7.	DC characteristics . . . . .	18
Table 8.	16/32 MHz crystal oscillator reference clock . . . . .	18
Table 9.	32 kHz crystal oscillator reference clock . . . . .	19
Table 10.	32 kHz RC oscillator reference clock . . . . .	19
Table 11.	RF receiver characteristics . . . . .	19
Table 12.	RF transmitter characteristics . . . . .	20
Table 13.	RSSI characteristics . . . . .	20
Table 14.	ADC characteristics . . . . .	20
Table 15.	Battery monitor characteristics . . . . .	21
Table 16.	Analog comparator characteristics . . . . .	21
Table 17.	External component list . . . . .	28
Table 18.	SnPb eutectic process (from J-STD-020D) . . . . .	33
Table 19.	Lead-free process (from J-STD-020D) . . . . .	33
Table 20.	Abbreviations . . . . .	35
Table 21.	Revision history . . . . .	36

## 21. Figures

---

Fig 1.	Block diagram	4
Fig 2.	Pin configuration for HVQFN48	5
Fig 3.	Pin configuration for HVQFN32	5
Fig 4.	Pin configuration for HVQFN40	6
Fig 5.	Memory address map	11
Fig 6.	QN9020 typical application schematic with DC-to-DC converter	22
Fig 7.	QN9020 typical application schematic without DC-to-DC converter	23
Fig 8.	QN9021 typical application schematic with DC-to-DC converter	24
Fig 9.	QN9021 typical application schematic without DC-to-DC converter	25
Fig 10.	QN9022 typical application schematic with DC-to-DC converter	26
Fig 11.	QN9022 typical application schematic without DC-to-DC converter	27
Fig 12.	Package outline SOT778-4 (HVQFN48)	29
Fig 13.	Package outline SOT617-13 (HVQFN32)	30
Fig 14.	Package outline SOT1369-2 (HVQFN40)	31
Fig 15.	Temperature profiles for large and small components	34

---

Please be aware that important notices concerning this document and the product(s) described herein, have been included in section 'Legal information'.

---

© NXP Semiconductors N.V. 2018.

All rights reserved.

For more information, please visit: <http://www.nxp.com>

For sales office addresses, please send an email to: [salesaddresses@nxp.com](mailto:salesaddresses@nxp.com)

Date of release: 21 November 2018

Document identifier: QN902x

## 22. Contents



<b>1</b>	<b>Introduction</b> .....	<b>1</b>
<b>2</b>	<b>General description</b> .....	<b>1</b>
<b>3</b>	<b>Features and benefits</b> .....	<b>1</b>
<b>4</b>	<b>Applications</b> .....	<b>3</b>
<b>5</b>	<b>Profiles and services</b> .....	<b>3</b>
<b>6</b>	<b>Ordering information</b> .....	<b>3</b>
<b>7</b>	<b>Block diagram</b> .....	<b>4</b>
<b>8</b>	<b>Pinning information</b> .....	<b>5</b>
8.1	Pinning .....	5
8.2	Pin description .....	6
<b>9</b>	<b>Functional description</b> .....	<b>10</b>
9.1	MCU subsystem .....	10
9.1.1	MCU .....	11
9.1.2	Memory organization .....	11
9.1.3	RESET generation .....	11
9.1.4	Nested Vectored Interrupt Controller (NVIC) ..	12
9.1.5	Clock and power management .....	12
9.1.6	Serial Wire Debug (SWD) interface .....	13
9.2	Flash .....	13
9.3	Digital peripherals .....	13
9.3.1	TIMER 0/1/2/3 .....	13
9.3.2	Real-Time Clock (RTC) .....	13
9.3.3	WatchDog Timer (WDT) .....	13
9.3.4	Sleep timer .....	14
9.3.5	PWM .....	14
9.3.6	DMA .....	14
9.3.7	Random number generator .....	14
9.3.8	AES coprocessor .....	14
9.4	Communication interfaces .....	14
9.4.1	UART 0/1 .....	14
9.4.2	SPI 0/1 .....	14
9.4.3	I <sup>2</sup> C-bus .....	15
9.5	Radio and analog peripherals .....	15
9.5.1	RF transceiver .....	15
9.5.2	On-chip oscillators .....	15
9.5.3	DC-to-DC converter .....	15
9.5.4	General-purpose ADC .....	16
9.5.5	Analog comparator .....	16
9.5.6	Battery monitor .....	16
<b>10</b>	<b>Limiting values</b> .....	<b>17</b>
<b>11</b>	<b>Recommended operating conditions</b> .....	<b>17</b>
<b>12</b>	<b>Characteristics</b> .....	<b>18</b>
12.1	DC characteristics .....	18
<b>13</b>	<b>Application information</b> .....	<b>22</b>
13.1	Schematic for QN9020 with DC-to-DC converter .....	22
13.2	Schematic for QN9020 without DC-to-DC converter	23
13.3	Schematic for QN9021 with DC-to-DC converter .....	24
13.4	Schematic for QN9021 without DC-to-DC converter	25
13.5	Schematic for QN9022 with DC-to-DC converter .....	26
13.6	Schematic for QN9022 without DC-to-DC converter	27

13.7	QN902x external component list . . . . .	28
<b>14</b>	<b>Package outline . . . . .</b>	<b>29</b>
<b>15</b>	<b>Soldering of SMD packages . . . . .</b>	<b>32</b>
15.1	Introduction to soldering . . . . .	32
15.2	Wave and reflow soldering . . . . .	32
15.3	Wave soldering . . . . .	32
15.4	Reflow soldering . . . . .	33
<b>16</b>	<b>Abbreviations . . . . .</b>	<b>35</b>
<b>17</b>	<b>Revision history . . . . .</b>	<b>36</b>
<b>18</b>	<b>Legal information . . . . .</b>	<b>37</b>
18.1	Data sheet status . . . . .	37
18.2	Definitions . . . . .	37
18.3	Disclaimers . . . . .	37
18.4	Trademarks . . . . .	38
<b>19</b>	<b>Contact information . . . . .</b>	<b>38</b>
<b>20</b>	<b>Tables . . . . .</b>	<b>39</b>
<b>21</b>	<b>Figures . . . . .</b>	<b>40</b>
<b>22</b>	<b>Contents . . . . .</b>	<b>41</b>





## Looking for pricing, stock, or lifecycle information?

Click below to explore more details on WIN SOURCE:

-  [View QN9020/DY on WIN SOURCE](#)
-  [NXP / Nexperia Information](#)

## Optimize Your Supply Chain with WIN SOURCE Solutions

-  Global Sourcing Solution
-  Obsolete Management
-  Cost Control Management
-  Shortage Management
-  Alternative Solution
-  Excess Inventory Management