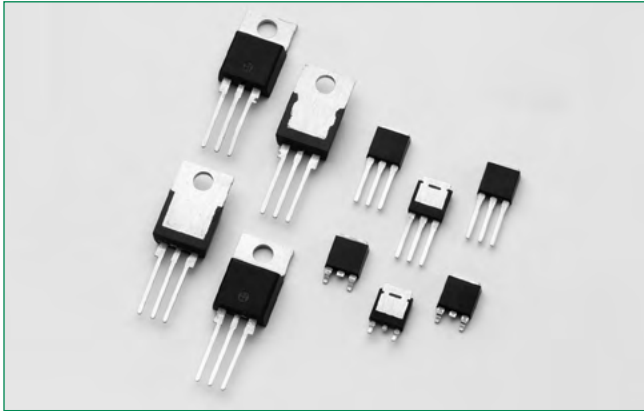




**THE DATASHEET OF  
Q6004V4TP**



### Lxx04xx & Qxx04xx Series



#### Agency Approval

Agency	Agency File Number
	E71639

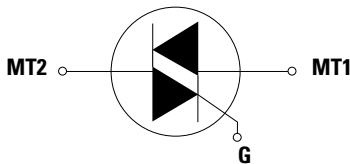
#### Main Features

Symbol	Value	Unit
$I_{T(RMS)}$	4	A
$V_{DRM}/V_{RRM}$	400, 600, 800 or 1000	V
$I_{GT(Q1)}$	3 to 25	mA

**Notes:**

- L Package only.
- 400V and 600V for Sensitive Triac (L Device Type)
- 400V, 600V, 800V, or 1000V for Standard Triac (Q Device Type)

#### Schematic Symbol



#### Description

The Lxx04xx and Qxx04xx are 4 Amp bidirectional solid state switch series. They are designed for AC switching and phase control applications such as motor speed and temperature modulation controls, lighting controls, and static switching relays.

**Sensitive** type devices guarantee gate control in Quadrants I & IV as needed for digital control circuitry.

**Standard** type devices normally operate in Quadrants I & III triggered from AC line.

#### Features & Benefits

- Surge capability up to 55 A
- The L-package has an isolation rating of 2500V<sub>RMS</sub>
- Solid-state switching eliminates arcing or contact bounce that create voltage transients
- No contacts to wear out from reaction of switching events
- Restricted (or limited) RFI generation, depending on activation point of sine wave
- Requires only a short gate activation pulse in each half-cycle
- RoHS-compliant
- Glass – passivated junctions
- Voltage capability up to 1000 V

#### Applications

Typical applications are AC solid-state switches, power tools, home/brown goods and white goods appliances.

Sensitive gate Triacs can be directly driven by microprocessor or popular opto-couplers/isolators.

Internally constructed isolated packages are offered for ease of heat sinking with highest isolation voltage.

#### Absolute Maximum Ratings — Sensitive Triacs (4 Quadrants)

Symbol	Parameter	Value	Unit
$I_{T(RMS)}$	RMS on-state current (full sine wave)	Lxx04Ly $T_c = 90^\circ\text{C}$	4 A
		Lxx04Vy/Lxx04Dy $T_c = 95^\circ\text{C}$	
		Lxx04Ry $T_c = 100^\circ\text{C}$	
$I_{TSM}$	Non repetitive surge peak on-state current (full cycle, $T_j$ initial = 25°C)	f = 50 Hz t = 20 ms	33 40 A
		f = 60 Hz t = 16.7 ms	
$I^2t$	$I^2t$ Value for fusing	$t_p = 8.3$ ms	6.6 A <sup>2</sup> s
di/dt	Critical rate of rise of on-state current ( $I_G = 50\text{mA}$ with $\leq 0.1\mu\text{s}$ rise time)	f = 120 Hz $T_j = 110^\circ\text{C}$	50 A/ $\mu\text{s}$
$I_{GTM}$	Peak gate trigger current	$t_p = 20\mu\text{s}$ $T_j = 110^\circ\text{C}$	4 A
$P_{G(AV)}$	Average gate power dissipation	$T_j = 110^\circ\text{C}$	0.3 W
$T_{stg}$	Storage temperature range	-	-40 to 150 °C
$T_j$	Operating junction temperature range	-	-40 to 110 °C

Note: xx = voltage/10, y = sensitivity

### Absolute Maximum Ratings — Standard Triacs

Symbol	Parameter	Value	Unit	
$I_{T(RMS)}$	RMS on-state current (full sine wave)	Qxx04Ly $T_C = 100^\circ\text{C}$	4	A
		Qxx04Vy/Qxx04Dy $T_C = 110^\circ\text{C}$		
		Qxx04Ry $T_C = 115^\circ\text{C}$		
$I_{TSM}$	Non repetitive surge peak on-state current (full cycle, $T_J$ initial = $25^\circ\text{C}$ )	f = 50 Hz t = 20 ms	46	A
		f = 60 Hz t = 16.7 ms	55	
$I^2t$	$I^2t$ Value for fusing	$t_p = 8.3$ ms	12.5	$\text{A}^2\text{s}$
di/dt	Critical rate of rise of on-state current ( $I_G = 50\text{mA}$ with $\leq 0.1\mu\text{s}$ rise time)	f = 120 Hz $T_J = 125^\circ\text{C}$	50	$\text{A}/\mu\text{s}$
$I_{GTM}$	Peak gate trigger current	$t_p = 20\mu\text{s}$ $T_J = 125^\circ\text{C}$	4	A
$P_{G(AV)}$	Average gate power dissipation	$T_J = 125^\circ\text{C}$	0.3	W
$T_{stg}$	Storage temperature range		-40 to 150	$^\circ\text{C}$
$T_J$	Operating junction temperature range		-40 to 125	$^\circ\text{C}$

Note: xx = voltage/10, y = sensitivity

### Electrical Characteristics ( $T_J = 25^\circ\text{C}$ , unless otherwise specified) — Sensitive Triac (4 Quadrants)

Symbol	Test Conditions	Quadrant	Lxx04x3	Lxx04x5	Lxx04x6	Lxx04x8	Unit
$I_{GT}$	$V_D = 12\text{V}$ $R_L = 60\ \Omega$	I – II – III	3	5	5	10	mA
		IV	3	5	10	20	
$V_{GT}$	$V_D = 12\text{V}$ $R_L = 60\ \Omega$	ALL	1.3				V
$V_{GD}$	$V_D = V_{DRM}$ $R_L = 3.3\ \text{k}\Omega$ $T_J = 110^\circ\text{C}$	ALL	0.2				V
$I_H$	$I_T = 100\text{mA}$	MAX.	5	10	10	15	mA
dv/dt	$V_D = V_{DRM}$ Gate Open $T_J = 100^\circ\text{C}$	400V	25	25	30	35	$\text{V}/\mu\text{s}$
		600V	15	15	20	25	
(dv/dt)c	(di/dt)c = 2.16 A/ms $T_J = 110^\circ\text{C}$	TYP.	0.5	1	1	1	$\text{V}/\mu\text{s}$
$t_{gt}$	$I_G = 2 \times I_{GT}$ PW = 15 $\mu\text{s}$ $I_T = 5.6\ \text{A(pk)}$	TYP.	2.8	3.0	3.0	3.2	$\mu\text{s}$

### Electrical Characteristics ( $T_J = 25^\circ\text{C}$ , unless otherwise specified) — Standard Triac

Symbol	Test Conditions	Quadrant	Qxx04x3	Qxx04x4	Unit
$I_{GT}$	$V_D = 12\text{V}$ $R_L = 60\ \Omega$	I – II – III	10	25	mA
		IV	25	50	
$V_{GT}$	$V_D = 12\text{V}$ $R_L = 60\ \Omega$	I – II – III	1.3	1.3	V
$V_{GD}$	$V_D = V_{DRM}$ $R_L = 3.3\ \text{k}\Omega$ $T_J = 125^\circ\text{C}$	ALL	0.2	0.2	V
$I_H$	$I_T = 200\text{mA}$	MAX.	20	30	mA
dv/dt	$V_D = V_{DRM}$ Gate Open $T_J = 125^\circ\text{C}$	400V	40	75	$\text{V}/\mu\text{s}$
		600V	30	50	
		800V		40	
	$V_D = V_{DRM}$ Gate Open $T_J = 100^\circ\text{C}$	1000V		50	
(dv/dt)c	(di/dt)c = 2.16 A/ms $T_J = 125^\circ\text{C}$	TYP.	2	2	$\text{V}/\mu\text{s}$
$t_{gt}$	$I_G = 2 \times I_{GT}$ PW = 15 $\mu\text{s}$ $I_T = 5.6\ \text{A(pk)}$	TYP.	2.5	3.0	$\mu\text{s}$
dv/dt	VD = 2/3 VDRM Gate Open $T_J = 125^\circ\text{C}$	800V	40	-	$\text{V}/\mu\text{s}$

Note: xx = voltage/10, x = package

### Static Characteristics ( $T_J = 25^\circ\text{C}$ , unless otherwise specified)

Symbol	Test Conditions			Value	Unit		
$V_{TM}$	$I_{TM} = 5.6\text{A}$	$t_p = 380\ \mu\text{s}$	MAX.	1.60	V		
$I_{DRM}$ $I_{RRM}$	$V_{DRM} = V_{RRM}$	MAX.	Lxx04xy	$T_J = 25^\circ\text{C}$	400-600V	5	$\mu\text{A}$
				$T_J = 110^\circ\text{C}$	400-600V	200	$\mu\text{A}$
			Qxx04xy	$T_J = 25^\circ\text{C}$	400-1000V	10	$\mu\text{A}$
				$T_J = 125^\circ\text{C}$	400-800V	2	mA
	$T_J = 100^\circ\text{C}$	1000V	3				

### Thermal Resistances

Symbol	Parameter	Value	Unit
$R_{\theta(J-C)}$	Junction to case (AC)	L/Qxx04Dy	1.5
		L/Qxx04Ly	3.0
		L/Qxx04Ry	1.1
		L/Qxx04Vy	1.5
$R_{\theta(J-A)}$	Junction to ambient	L/Qxx04Ly	50
		L/Qxx04Ry	45
		L/Qxx04Vy	70

Note: xx = voltage/10, x = package, y = sensitivity

Figure 1: Definition of Quadrants

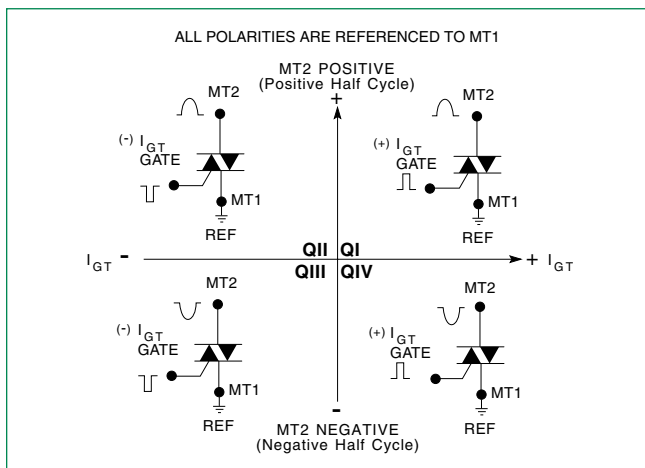
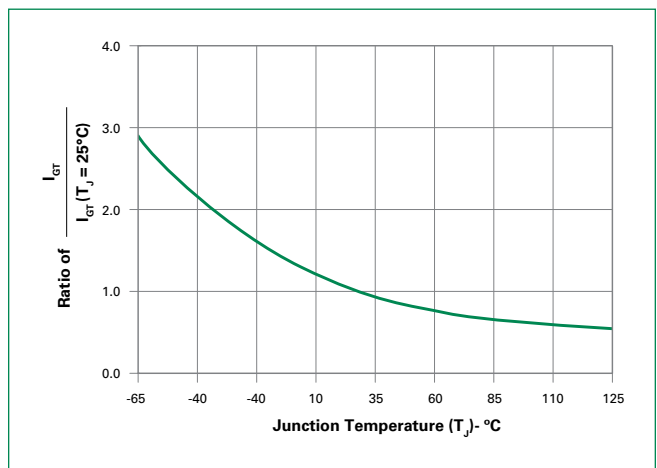


Figure 2: Normalized DC Gate Trigger Current for All Quadrants vs. Junction Temperature



### Additional Information



Datasheet

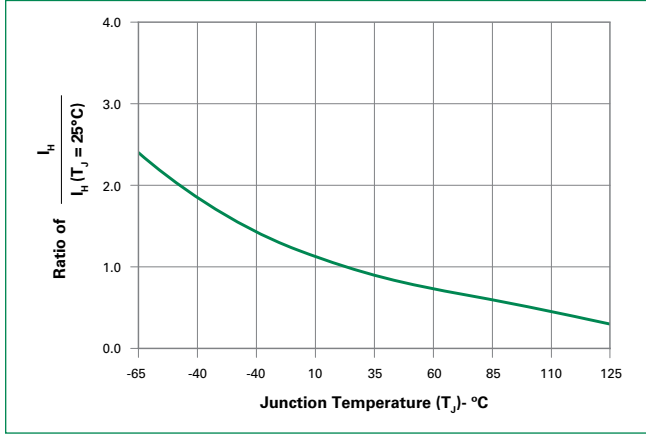


Resources

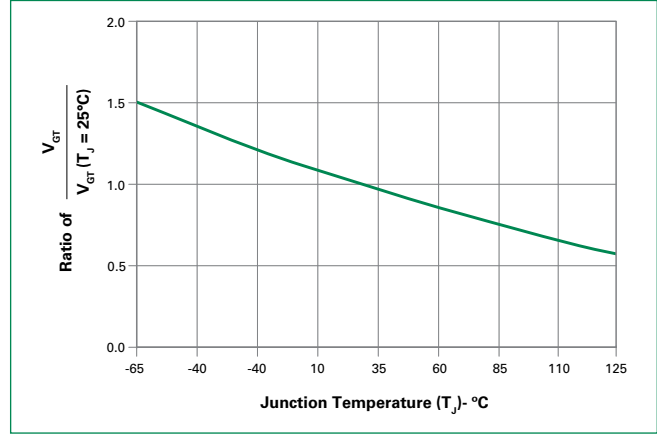


Samples

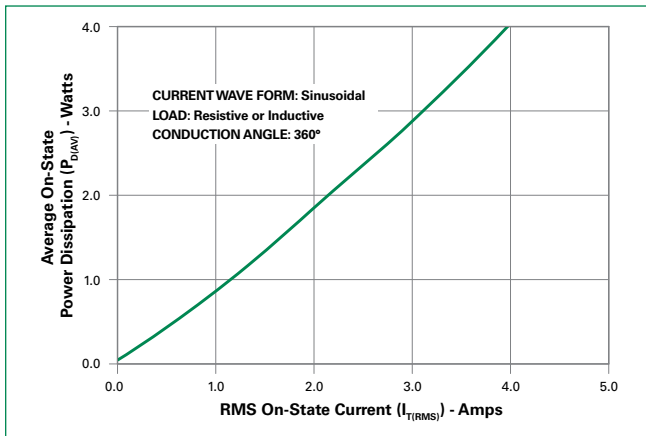
**Figure 3: Normalized DC Holding Current vs. Junction Temperature**



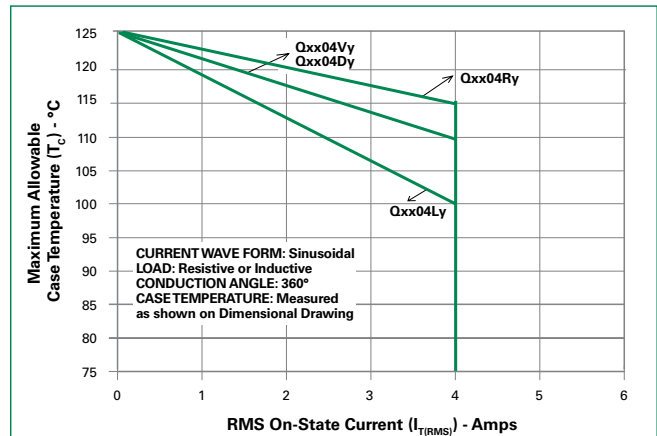
**Figure 4: Normalized DC Gate Trigger Voltage for All Quadrants vs. Junction Temperature**



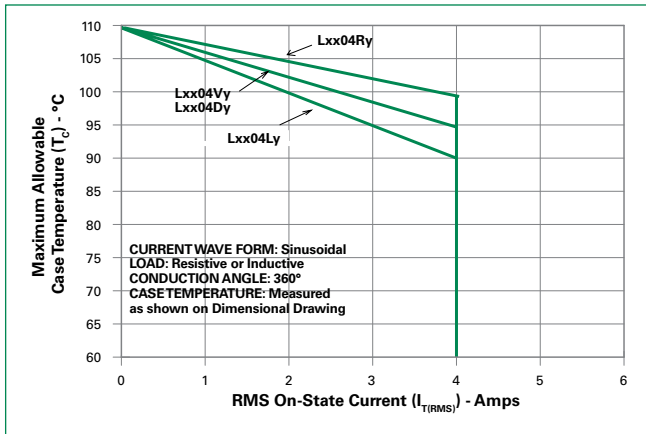
**Figure 5: Power Dissipation (Typical) vs. RMS On-State Current**



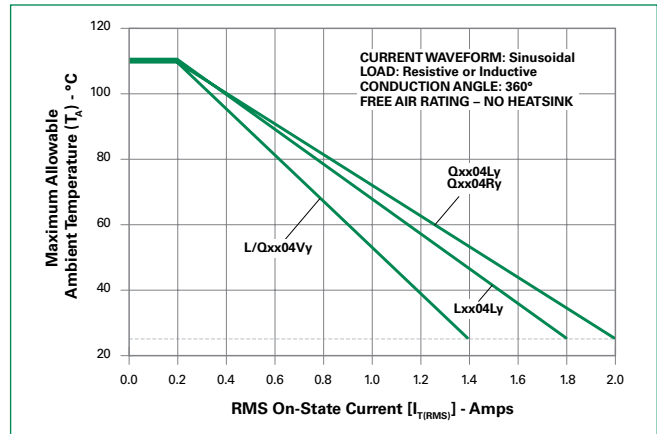
**Figure 6: Maximum Allowable Case Temperature vs. On-State Current**



**Figure 7: Maximum Allowable Case Temperature vs. On-State Current**

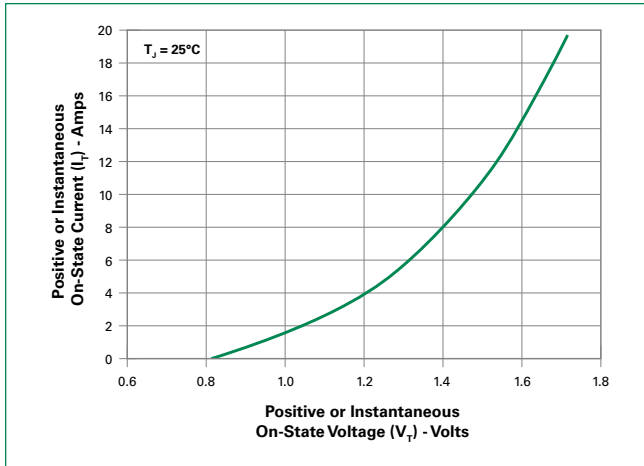


**Figure 8: Maximum Allowable Ambient Temperature vs. On-State Current**

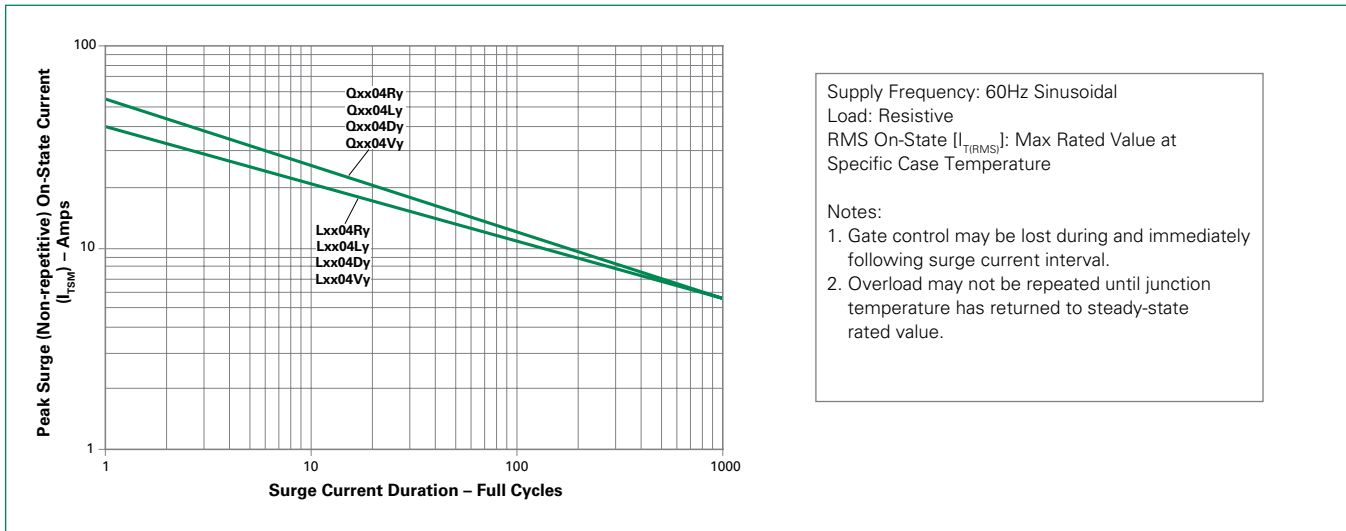


Note: xx = voltage/10, y = sensitivity

**Figure 9: On-State Current vs. On-State Voltage (Typical)**



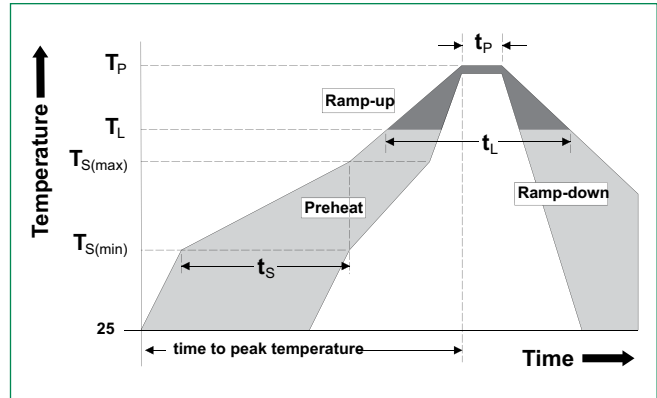
**Figure 10: Surge Peak On-State Current vs. Number of Cycles**



Note: xx = voltage/10, y = sensitivity

### Soldering Parameters

<b>Reflow Condition</b>		Pb – Free assembly
<b>Pre Heat</b>	- Temperature Min ( $T_{s(min)}$ )	150°C
	- Temperature Max ( $T_{s(max)}$ )	200°C
	- Time (min to max) ( $t_s$ )	60 – 180 secs
<b>Average ramp up rate (Liquidus Temp) (<math>T_L</math>) to peak</b>		5°C/second max
<b><math>T_{s(max)}</math> to <math>T_L</math> - Ramp-up Rate</b>		5°C/second max
<b>Reflow</b>	- Temperature ( $T_L$ ) (Liquidus)	217°C
	- Temperature ( $t_L$ )	60 – 150 seconds
<b>Peak Temperature (<math>T_p</math>)</b>		260°C <sup>+0/-5</sup>
<b>Time within 5°C of actual peak Temperature (<math>t_p</math>)</b>		20 – 40 seconds
<b>Ramp-down Rate</b>		5°C/second max
<b>Time 25°C to peak Temperature (<math>T_p</math>)</b>		8 minutes Max.
<b>Do not exceed</b>		280°C



### Physical Specifications

<b>Terminal Finish</b>	100% Matte Tin-plated
<b>Body Material</b>	UL Recognized compound meeting flammability rating V-0
<b>Terminal Material</b>	Copper Alloy

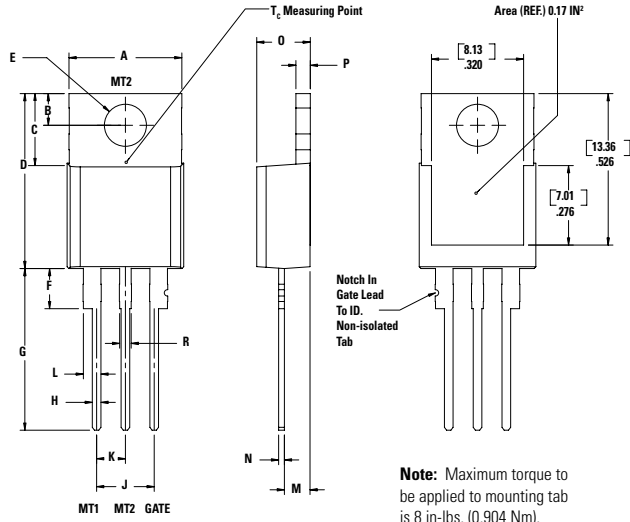
### Design Considerations

Careful selection of the correct component for the application's operating parameters and environment will go a long way toward extending the operating life of the Thyristor. Good design practice should limit the maximum continuous current through the main terminals to 75% of the component rating. Other ways to ensure long life for a power discrete semiconductor are proper heat sinking and selection of voltage ratings for worst case conditions. Overheating, overvoltage (including  $dv/dt$ ), and surge currents are the main killers of semiconductors. Correct mounting, soldering, and forming of the leads also help protect against component damage.

### Environmental Specifications

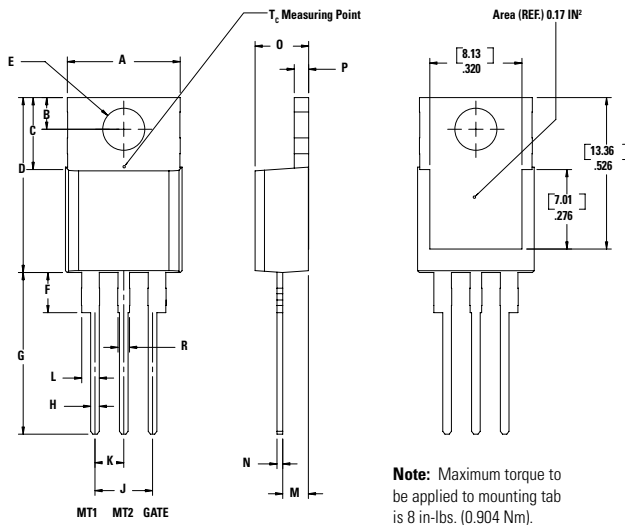
Test	Specifications and Conditions
<b>AC Blocking</b>	MIL-STD-750, M-1040, Cond A Applied Peak AC voltage @ 125°C for 1008 hours
<b>Temperature Cycling</b>	MIL-STD-750, M-1051, 100 cycles; -40°C to +150°C; 15-min dwell time
<b>Temperature/Humidity</b>	EIA / JEDEC, JESD22-A101 1008 hours; 320V - DC; 85°C; 85% rel humidity
<b>High Temp Storage</b>	MIL-STD-750, M-1031, 1008 hours; 150°C
<b>Low-Temp Storage</b>	1008 hours; -40°C
<b>Resistance to Solder Heat</b>	MIL-STD-750 Method 2031
<b>Solderability</b>	ANSI/J-STD-002, category 3, Test A
<b>Lead Bend</b>	MIL-STD-750, M-2036 Cond E

### Dimensions — TO-220AB (R-Package) — Non-Isolated Mounting Tab Common with Center Lead



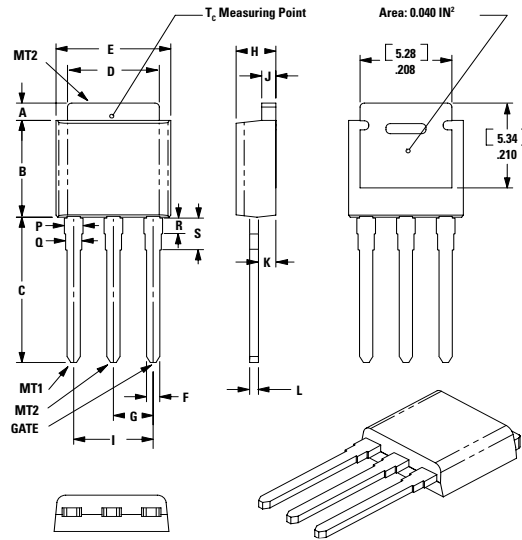
Dimension	Inches		Millimeters	
	Min	Max	Min	Max
A	0.380	0.420	9.65	10.67
B	0.105	0.115	2.67	2.92
C	0.230	0.250	5.84	6.35
D	0.590	0.620	14.99	15.75
E	0.142	0.147	3.61	3.73
F	0.110	0.130	2.79	3.30
G	0.540	0.575	13.72	14.61
H	0.025	0.035	0.64	0.89
J	0.195	0.205	4.95	5.21
K	0.095	0.105	2.41	2.67
L	0.060	0.075	1.52	1.91
M	0.085	0.095	2.16	2.41
N	0.018	0.024	0.46	0.61
O	0.178	0.188	4.52	4.78
P	0.045	0.060	1.14	1.52
R	0.038	0.048	0.97	1.22

### Dimensions — TO-220AB (L-Package) — Isolated Mounting Tab



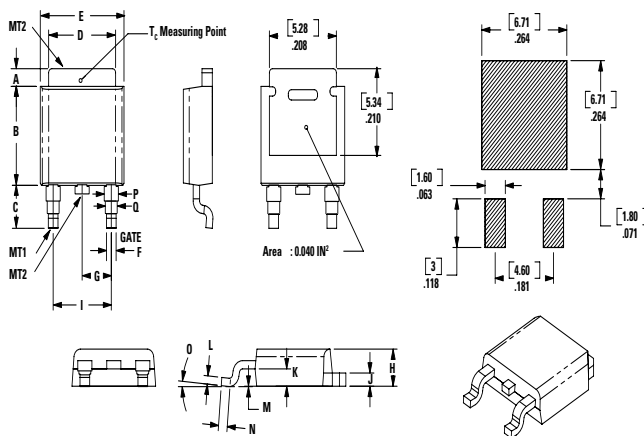
Dimension	Inches		Millimeters	
	Min	Max	Min	Max
A	0.380	0.420	9.65	10.67
B	0.105	0.115	2.67	2.92
C	0.230	0.250	5.84	6.35
D	0.590	0.620	14.99	15.75
E	0.142	0.147	3.61	3.73
F	0.110	0.130	2.79	3.30
G	0.540	0.575	13.72	14.61
H	0.025	0.035	0.64	0.89
J	0.195	0.205	4.95	5.21
K	0.095	0.105	2.41	2.67
L	0.060	0.075	1.52	1.91
M	0.085	0.095	2.16	2.41
N	0.018	0.024	0.46	0.61
O	0.178	0.188	4.52	4.78
P	0.045	0.060	1.14	1.52
R	0.038	0.048	0.97	1.22

### Dimensions — TO-251AA (V-Package) — V-PAK Through Hole



Dim	Inches			Millimeters		
	Min	Typ	Max	Min	Typ	Max
A	0.037	0.040	0.043	0.94	1.01	1.09
B	0.235	0.242	0.245	5.97	6.15	6.22
C	0.350	0.361	0.375	8.89	9.18	9.53
D	0.205	0.208	0.213	5.21	5.29	5.41
E	0.255	0.262	0.265	6.48	6.66	6.73
F	0.027	0.031	0.033	0.69	0.80	0.84
G	0.087	0.090	0.093	2.21	2.28	2.36
H	0.085	0.092	0.095	2.16	2.34	2.41
I	0.176	0.180	0.184	4.47	4.57	4.67
J	0.018	0.020	0.023	0.46	0.51	0.58
K	0.035	0.037	0.039	0.90	0.95	1.00
L	0.018	0.020	0.023	0.46	0.52	0.58
P	0.042	0.047	0.052	1.06	1.20	1.32
Q	0.034	0.039	0.044	0.86	1.00	1.11
R	0.034	0.039	0.044	0.86	1.00	1.11
S	0.074	0.079	0.084	1.86	2.00	2.11

### Dimensions — TO-252AA (D-Package) — D-PAK Surface Mount



Dim	Inches			Millimeters		
	Min	Typ	Max	Min	Typ	Max
A	0.037	0.040	0.043	0.94	1.01	1.09
B	0.235	0.243	0.245	5.97	6.16	6.22
C	0.106	0.108	0.113	2.69	2.74	2.87
D	0.205	0.208	0.213	5.21	5.29	5.41
E	0.255	0.262	0.265	6.48	6.65	6.73
F	0.027	0.031	0.033	0.69	0.80	0.84
G	0.087	0.090	0.093	2.21	2.28	2.36
H	0.085	0.092	0.095	2.16	2.33	2.41
I	0.176	0.179	0.184	4.47	4.55	4.67
J	0.018	0.020	0.023	0.46	0.51	0.58
K	0.035	0.037	0.039	0.90	0.95	1.00
L	0.018	0.020	0.023	0.46	0.51	0.58
M	0.000	0.000	0.004	0.00	0.00	0.10
N	0.021	0.026	0.027	0.53	0.67	0.69
O	0°	0°	5°	0°	0°	5°
P	0.042	0.047	0.052	1.06	1.20	1.32
Q	0.034	0.039	0.044	0.86	1.00	1.11

### Product Selector

Part Number	Voltage				Gate Sensitivity Quadrants		Type	Package
	400V	600V	800V	1000V	I – II – III	IV		
Lxx04L3	X	X	-	-	3 mA	3 mA	Sensitive Triac	TO-220L
Lxx04D3	X	X	-	-	3 mA	3 mA	Sensitive Triac	TO-252 D-PAK
Lxx04R3	X	X	-	-	3mA	3mA	Sensitive Triac	TO-220R
Lxx04V3	X	X	-	-	3 mA	3 mA	Sensitive Triac	TO-251 V-PAK
Lxx04L5	X	X	-	-	5 mA	5 mA	Sensitive Triac	TO-220L
Lxx04D5	X	X	-	-	5 mA	5 mA	Sensitive Triac	TO-252 D-PAK
Lxx04R5	X	X	-	-	5mA	5mA	Sensitive Triac	TO-220R
Lxx04V5	X	X	-	-	5 mA	5 mA	Sensitive Triac	TO-251 V-PAK
Lxx04L6	X	X	-	-	5 mA	10 mA	Sensitive Triac	TO-220L
Lxx04D6	X	X	-	-	5 mA	10 mA	Sensitive Triac	TO-252 D-PAK
Lxx04R6	X	X	-	-	5mA	10mA	Sensitive Triac	TO-220R
Lxx04V6	X	X	-	-	5 mA	10 mA	Sensitive Triac	TO-251 V-PAK
Lxx04L8	X	X	-	-	10 mA	20 mA	Sensitive Triac	TO-220L
Lxx04D8	X	X	-	-	10 mA	20 mA	Sensitive Triac	TO-252 D-PAK
Lxx04R8	X	X	-	-	10mA	20mA	Sensitive Triac	TO-220R
Lxx04V8	X	X	-	-	10 mA	20 mA	Sensitive Triac	TO-251 V-PAK
Qxx04L3	X	X	X	-	10 mA	-	Standard Triac	TO-220L
Qxx04D3	X	X	X	-	10 mA	-	Standard Triac	TO-252 D-PAK
Qxx04V3	X	X	X	-	10 mA	-	Standard Triac	TO-251 V-PAK
Qxx04R3	X	X	X	-	10mA	-	Standard Triac	TO-220R
Qxx04L4	X	X	X	X	25 mA	-	Standard Triac	TO-220L
Qxx04D4	X	X	X	X	25 mA	-	Standard Triac	TO-252 D-PAK
Qxx04R4	X	X	X	X	25mA	-	Standard Triac	TO-220R
Qxx04V4	X	X	X	X	25 mA	-	Standard Triac	TO-251 V-PAK

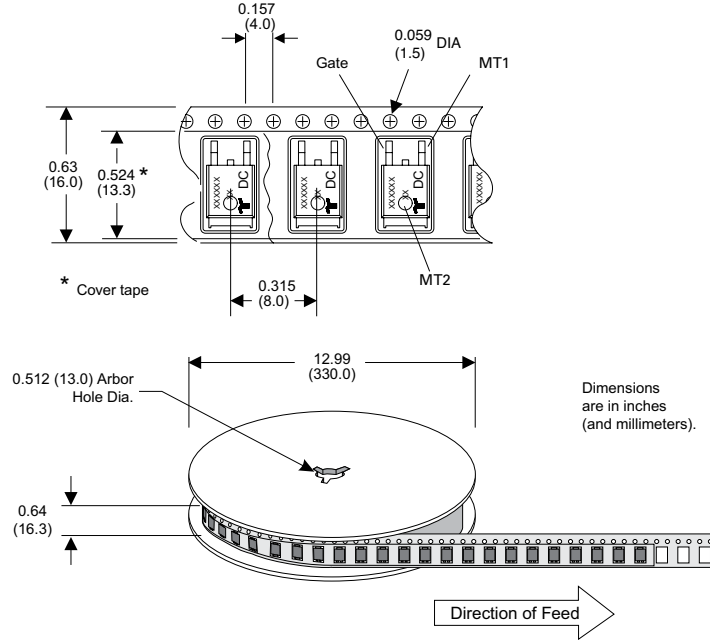
### Packing Options

Part Number	Marking	Weight	Packing Mode	Base Quantity
L/Qxx04LyTP	L/Qxx04Ly	2.2 g	Tube	1000 (50 per tube)
L/Qxx04DyRP	L/Qxx04Dy	0.3 g	Embossed Carrier	2500
L/Qxx04DyTP	L/Qxx04Dy	0.3 g	Tube Pack	750 (75 per tube)
L/Qxx04VyTP	L/Qxx04Vy	0.4 g	Tube Pack	750 (75 per tube)
L/Qxx04LyTP	L/Qxx04Ly	2.2g	Tube	1000 (50 per tube)
L/Qxx04RyTP	L/Qxx04Ry	2.2g	Tube	1000 (50 per tube)

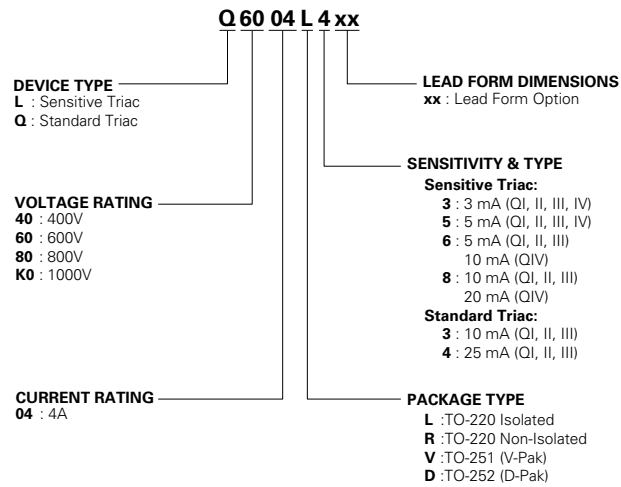
Note: xx = Voltage/10; y = Sensitivity

### TO-252 Embossed Carrier Reel Pack (RP) Specifications

Meets all EIA-481-2 Standards

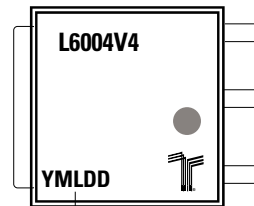


### Part Numbering System

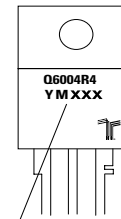


### Part Marking System

TO-251AA - (V Package)  
TO-252AA - (D Package)





TO-220 AB - (L and R Package)



**Date Code Marking**  
Y: Year Code  
M: Month Code  
XXX: Lot Trace Code

## Looking for pricing, stock, or lifecycle information?

Click below to explore more details on WIN SOURCE:

-  [View Q6004V4TP on WIN SOURCE](#)
-  [Littelfuse Inc. Information](#)

## Optimize Your Supply Chain with WIN SOURCE Solutions

-  Global Sourcing Solution
-  Obsolete Management
-  Cost Control Management
-  Shortage Management
-  Alternative Solution
-  Excess Inventory Management