



**THE DATASHEET OF
PTN3363BSMP**



PTN3363

Low power HDMI/DVI level shifter with active DDC buffer,
supporting 3.4 Gbit/s operation

Rev. 1 — 12 August 2014

Product data sheet

1. General description

PTN3363 is a low power, high-speed level shifter device which converts four lanes of low-swing AC-coupled differential input signals to DVI v1.0 and HDMI v1.4b compliant open-drain current-steering differential output signals, up to 3.4 Gbit/s per lane to support 36-bit deep color mode, 4K × 2K video format or 3D video data transport. Each of these lanes provides a level-shifting differential active buffer, with built-in Equalization, to translate from low-swing AC-coupled differential signaling on the source side, to TMDS-type DC-coupled differential current-mode signaling terminated into 50 Ω to 3.3 V on the sink side. Additionally, the PTN3363 provides a single-ended active buffer for voltage translation of the HPD signal from 5 V on the sink side to 3.3 V on the source side and provides a channel with active buffering and level shifting of the DDC channel (consisting of a clock and a data line) between 3.3 V source-side and 5 V sink-side. The DDC channel is implemented using active I²C-bus buffer technology providing re-driving and level shifting as well as disablement (isolation between source and sink) of the clock and data lines.

The low-swing AC-coupled differential input signals to the PTN3363 typically come from a display source with multi-mode I/O, which supports multiple display standards, for example, DisplayPort, HDMI and DVI. While the input differential signals are configured to carry DVI or HDMI coded data, they do not comply with the electrical requirements of the DVI v1.0 or HDMI v1.4b specification. By using PTN3363, chip set vendors are able to implement such reconfigurable I/Os on multi-mode display source devices, allowing the support of multiple display standards while keeping the number of chip set I/O pins low. See [Figure 1](#).

The PTN3363 main high-speed differential lanes feature low-swing self-biasing differential inputs which are compliant to the electrical specifications of *DisplayPort Standard v1.2a* and/or *PCI Express Standard v1.1*, and open-drain current-steering differential outputs compliant to DVI v1.0 and HDMI v1.4b electrical specifications. The I²C-bus channel actively buffers as well as level-translates the DDC signals. The PTN3363 supports standby mode in order to minimize current consumption when Hot Plug Detect signal HPD_SINK is LOW.

PTN3363 is powered from a single 3.3 V power supply consuming a small amount of power (72 mW typical) and is offered in a 32-terminal HVQFN32 package.



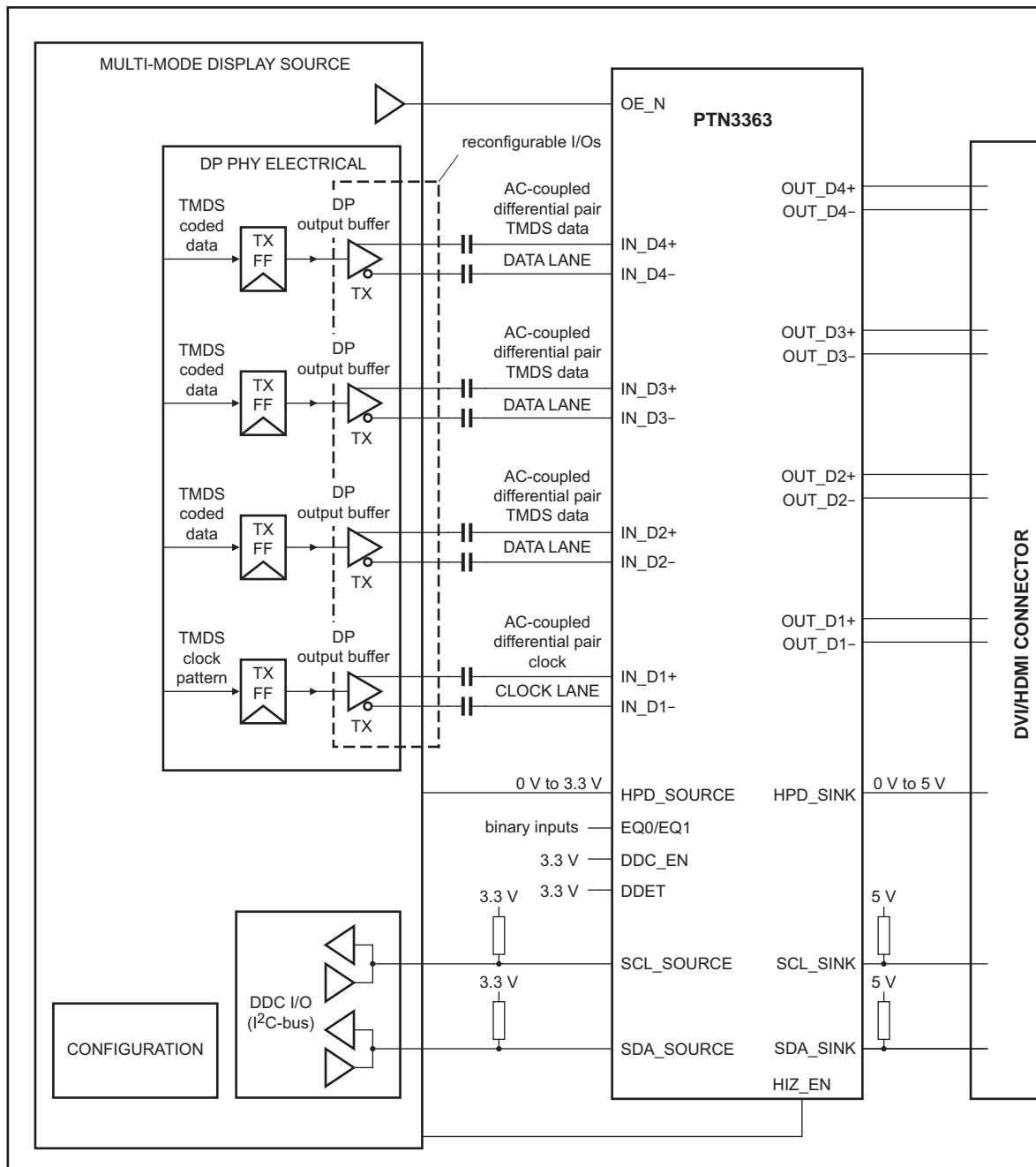

002aah235

Remark: TMDS clock and data lanes can be assigned arbitrarily and interchangeably to IN_D[4:1].

Fig 1. Typical HDMI/DVI level shifter application system diagram

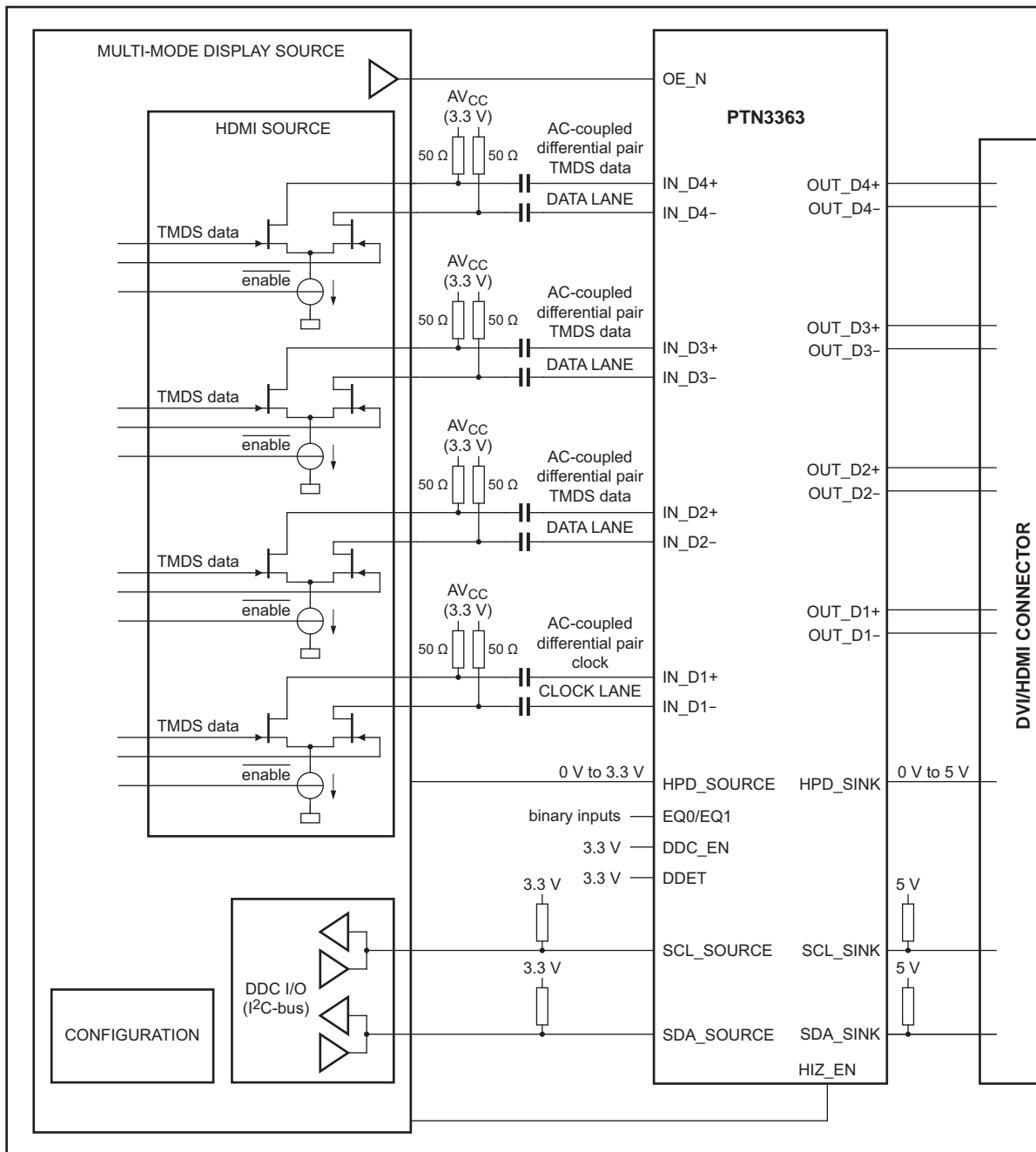

002aah251

Fig 2. Typical HDMI redriver application system diagram

2. Features and benefits

2.1 High-speed TMDS level shifting

- Converts four lanes of low-swing AC-coupled differential input signals to DVI v1.0 and HDMI v1.4b compliant open-drain current-steering differential output signals
- TMDS level shifting operation up to 3.4 Gbit/s per lane (340 MHz TMDS clock) supporting 4K × 2K 3 Gbit/s and 3D video formats
- Programmable receive equalization
- Integrated 50 Ω termination resistors for self-biasing differential inputs
- Programmable high-impedance termination resistors for HDMI redriver usage with external 50 Ω termination resistors
- Back-current safe outputs to disallow current when device power is off and monitor is on
- Disable feature to turn off TMDS inputs and outputs and to enter low power condition
- Selectable differential output termination on TMDS channels

2.2 DDC level shifting

- Integrated DDC buffering and level shifting (3.3 V source to 5 V sink side and vice versa)
- Rise time accelerator on connector side DDC ports
- Up to 400 kHz I²C-bus clock frequency
- Back-power safe sink-side terminals to disallow backdrive current when power is off or when DDC is not enabled

2.3 HPD level shifting

- HPD non-inverting level shift from 0 V on the sink side to 0 V on the source side, or from 5 V on the sink side to 3.3 V on the source side
- Integrated 200 kΩ pull-down resistor on HPD sink input guarantees 'input LOW' when no display is plugged in
- Back-power safe design on HPD_SINK to disallow backdrive current when power is off

2.4 HDMI dongle detection support

- Incorporates I²C-bus slave ROM
- Responds to DDC read to address 81h
- Feature enabled by pins DDET and DDC_EN (must be enabled for correct operation in accordance with DisplayPort interoperability guideline)

2.5 General

- Power supply 2.8 V to 3.6 V
- ESD resilience to 8 kV HBM, 1 kV CDM
- Power-saving modes
- Back-current-safe design on all sink-side main link, DDC and HPD terminals
- Transparent operation: no retiming or software configuration required
- 32-terminal HVQFN32 package

3. Applications

- PC motherboard/graphics card
- Docking station
- DisplayPort to HDMI adapters supporting 4K × 2K and 3D video formats
- DisplayPort to DVI adapters required to drive long cables

4. Ordering information

Table 1. Ordering information

Type number	Topside mark	Package		
		Name	Description	Version
PTN3363BS	P3363	HVQFN32	plastic thermal enhanced very thin quad flat package; no leads; 32 terminals; body 5 × 5 × 0.85 mm	SOT617-3

4.1 Ordering options

Table 2. Ordering options

Type number	Orderable part number	Package	Packing method	Minimum order quantity	Temperature
PTN3363BS	PTN3363BSMP	HVQFN32	Reel 13" Q2/T3 *standard mark SMD dry pack	6000	T _{amb} = -40 °C to +105 °C

5. Functional diagram

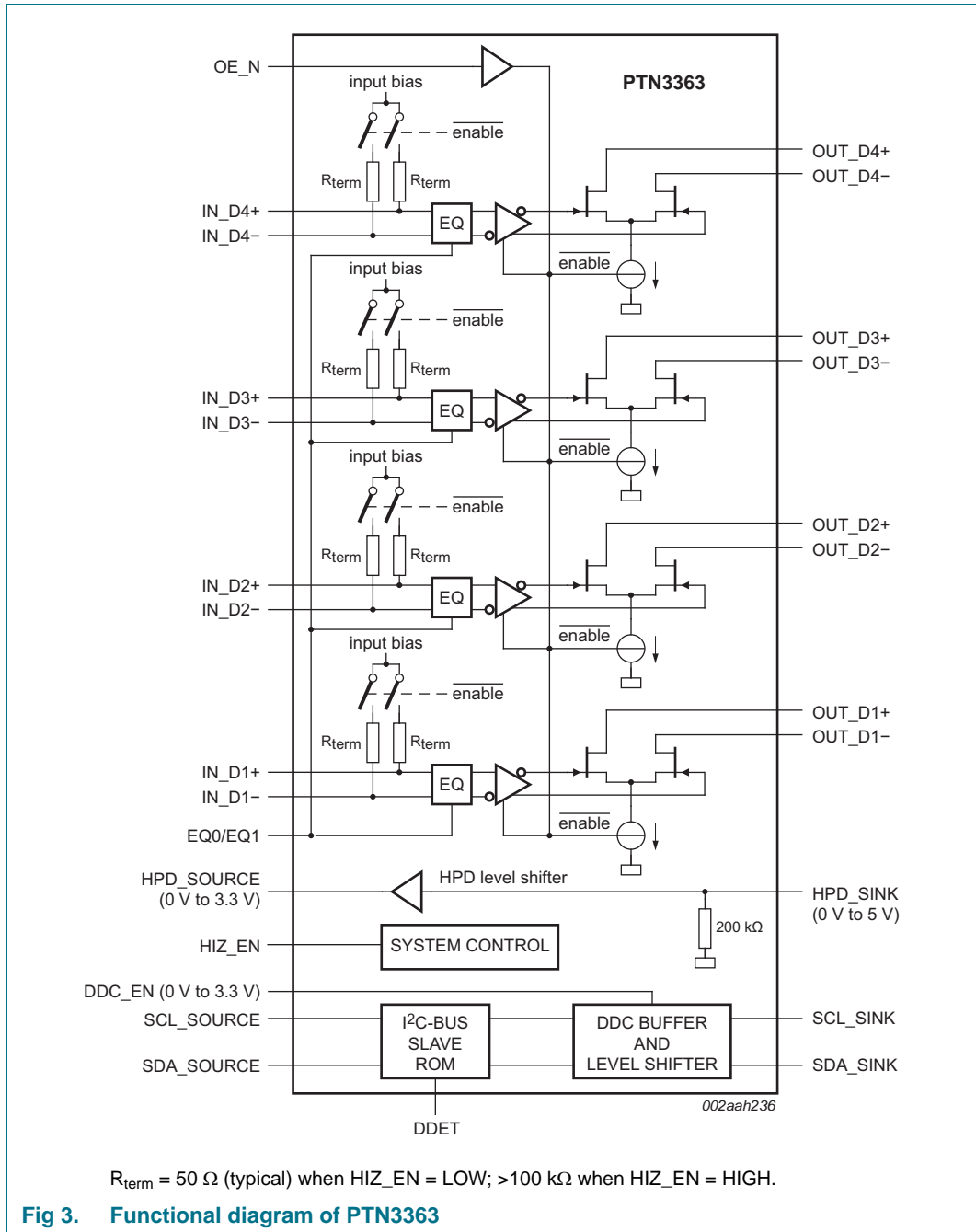

6. Pinning information

6.1 Pinning

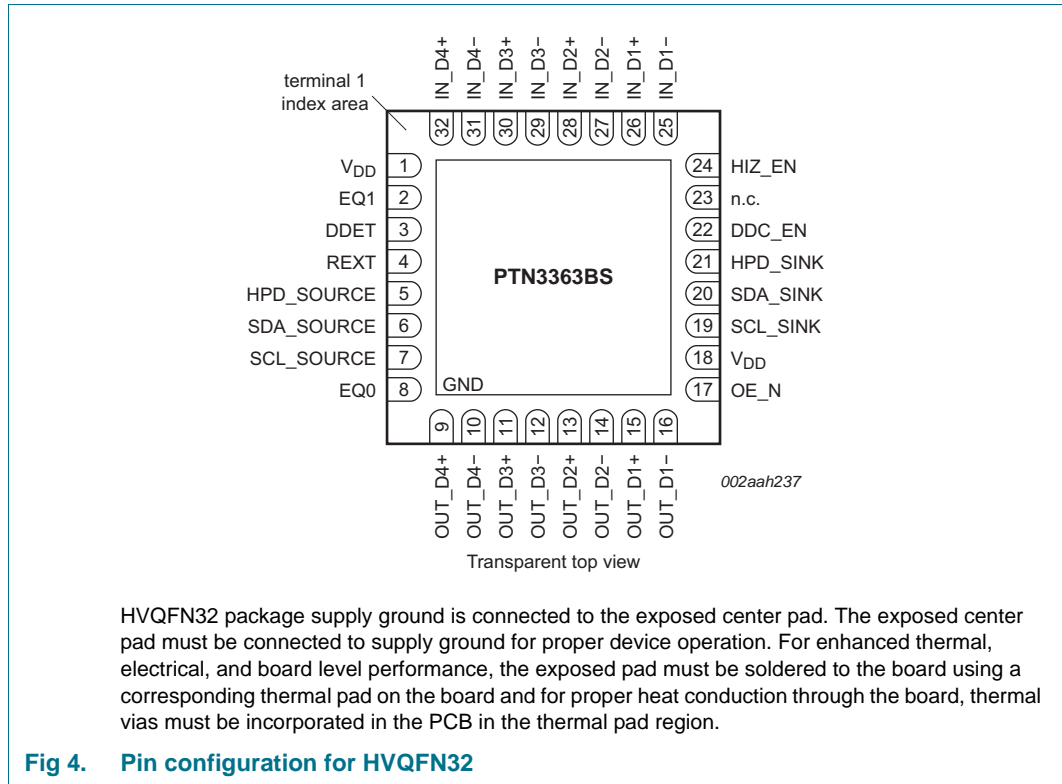

6.2 Pin description

Table 3. Pin description

Symbol	Pin	Type	Description
OE_N, IN_Dx and OUT_Dx signals			
OE_N	17	3.3 V low-voltage CMOS single-ended input	Output Enable and power-saving function for high-speed differential level shifter path. When OE_N = HIGH: IN_Dx termination = high-Z OUT_Dx outputs = high-Z; zero output current When OE_N = LOW: IN_Dx termination = 50 Ω OUT_Dx outputs = active
IN_D4+	32	Self-biasing differential input	Low-swing differential input from display source. IN_D4+ makes a differential pair with IN_D4-. The input to this pin must be AC coupled externally.
IN_D4-	31	Self-biasing differential input	Low-swing differential input from display source. IN_D4- makes a differential pair with IN_D4+. The input to this pin must be AC coupled externally.

Table 3. Pin description ...continued

Symbol	Pin	Type	Description
IN_D3+	30	Self-biasing differential input	Low-swing differential input from display source. IN_D3+ makes a differential pair with IN_D3-. The input to this pin must be AC coupled externally.
IN_D3-	29	Self-biasing differential input	Low-swing differential input from display source. IN_D3- makes a differential pair with IN_D3+. The input to this pin must be AC coupled externally.
IN_D2+	28	Self-biasing differential input	Low-swing differential input from display source. IN_D2+ makes a differential pair with IN_D2-. The input to this pin must be AC coupled externally.
IN_D2-	27	Self-biasing differential input	Low-swing differential input from display source. IN_D2- makes a differential pair with IN_D2+. The input to this pin must be AC coupled externally.
IN_D1+	26	Self-biasing differential input	Low-swing differential input from display source. IN_D1+ makes a differential pair with IN_D1-. The input to this pin must be AC coupled externally.
IN_D1-	25	Self-biasing differential input	Low-swing differential input from display source. IN_D1- makes a differential pair with IN_D1+. The input to this pin must be AC coupled externally.
OUT_D4+	9	TMDS differential output	HDMI-compliant TMDS output. OUT_D4+ makes a differential pair with OUT_D4-. OUT_D4+ is in phase with IN_D4+.
OUT_D4-	10	TMDS differential output	HDMI-compliant TMDS output. OUT_D4- makes a differential pair with OUT_D4+. OUT_D4- is in phase with IN_D4-.
OUT_D3+	11	TMDS differential output	HDMI-compliant TMDS output. OUT_D3+ makes a differential pair with OUT_D3-. OUT_D3+ is in phase with IN_D3+.
OUT_D3-	12	TMDS differential output	HDMI-compliant TMDS output. OUT_D3- makes a differential pair with OUT_D3+. OUT_D3- is in phase with IN_D3-.
OUT_D2+	13	TMDS differential output	HDMI-compliant TMDS output. OUT_D2+ makes a differential pair with OUT_D2-. OUT_D2+ is in phase with IN_D2+.
OUT_D2-	14	TMDS differential output	HDMI-compliant TMDS output. OUT_D2- makes a differential pair with OUT_D2+. OUT_D2- is in phase with IN_D2-.
OUT_D1+	15	TMDS differential output	HDMI-compliant TMDS output. OUT_D1+ makes a differential pair with OUT_D1-. OUT_D1+ is in phase with IN_D1+.
OUT_D1-	16	TMDS differential output	HDMI-compliant TMDS output. OUT_D1- makes a differential pair with OUT_D1+. OUT_D1- is in phase with IN_D1-.
HPD and DDC signals			
HPD_SINK	21	5 V CMOS single-ended input	0 V to 5 V (nominal) input signal. This signal comes from the DVI or HDMI sink. A HIGH value indicates that the sink is connected; a LOW value indicates that the sink is disconnected. HPD_SINK is pulled down by an integrated 200 k Ω pull-down resistor.
HPD_SOURCE	5	3.3 V CMOS single-ended output	0 V to 3.3 V (nominal) output signal. This is level-shifted version of the HPD_SINK signal.
SCL_SOURCE	7	single-ended 3.3 V open-drain DDC I/O	3.3 V source-side DDC clock I/O. Pulled up by external termination to 3.3 V. 5 V tolerant I/O.
SDA_SOURCE	6	single-ended 3.3 V open-drain DDC I/O	3.3 V source-side DDC data I/O. Pulled up by external termination to 3.3 V. 5 V tolerant I/O.
SCL_SINK	19	single-ended 5 V open-drain DDC I/O	5 V sink-side DDC clock I/O. Pulled up by external termination to 5 V. Provides rise time acceleration for LOW-to-HIGH transitions.

Table 3. Pin description ...continued

Symbol	Pin	Type	Description
SDA_SINK	20	single-ended 5 V open-drain DDC I/O	5 V sink-side DDC data I/O. Pulled up by external termination to 5 V. Provides rise time acceleration for LOW-to-HIGH transitions.
DDC_EN	22	3.3 V CMOS input	Enables the DDC buffer and level shifter. When DDC_EN = LOW, buffer/level shifter is disabled. When DDC_EN = HIGH, buffer and level shifter are enabled.
Supply and ground			
V _{DD}	1, 18	2.8 V to 3.3 V DC supply	Supply voltage; 3.3 V ± 10 %.
GND ^[1]	center pad	ground	Supply ground. The exposed center pad must be connected to system ground for proper operation.
Feature control signals			
REXT	4	analog I/O	Current sense port used to provide an accurate current reference for the differential outputs OUT_Dx. For best output voltage swing accuracy, use of a 12.4 kΩ resistor (1 % tolerance) from this terminal to GND is recommended. May also be tied to GND directly (0 Ω). See Section 7.2 for details.
DDET	3	3.3 V input	Dongle detect enable input. When HIGH, the dongle detect function via I ² C is active. When LOW, the dongle detect function does not respond to an I ² C-bus command. Must be tied to GND or V _{DD} either directly or via a resistor. Note that this pin may not be left open-circuited. When used in an HDMI dongle, this pin must be tied HIGH for correct operation in accordance with DisplayPort interoperability guideline. When used in a DVI dongle, this pin must be tied LOW.
EQ1	2	3.3 V low-voltage CMOS inputs	Equalizer setting input pins. These pins can be board-strapped to one of two decode values: short to GND, short to V _{DD} . See Table 5 for truth table.
EQ0	8		
HIZ_EN	24	high input impedance control input	If HIZ_EN pin is HIGH, the input interface IN_Dx has high-Z terminations. If the pin is LOW, the input interface has 50 Ω (typical) termination.
n.c.	23	-	Not connected; leave this pin open.

- [1] HVQFN32 package supply ground is connected to the exposed center pad. The exposed center pad must be connected to supply ground for proper device operation. For enhanced thermal, electrical, and board level performance, the exposed pad must be soldered to the board using a corresponding thermal pad on the board and for proper heat conduction through the board, thermal vias must be incorporated in the PCB in the thermal pad region.

7. Functional description

Refer to [Figure 3 “Functional diagram of PTN3363”](#).

The PTN3363 level shifts four lanes of low-swing AC-coupled differential input signals to DVI and HDMI-compliant open-drain current-steering differential output signals, up to 3.4 Gbit/s per lane to support 36-bit deep color, 3 Gbit/s and 3D modes. It has integrated 50 Ω termination resistors for AC-coupled differential input signals. An enable signal OE_N can be used to turn off the TMDS inputs and outputs, thereby minimizing power consumption to ultra low level. The TMDS outputs are back-power safe to disallow current flow from a powered sink while the PTN3363 is unpowered.

The PTN3363's DDC channel provides active level shifting and buffering, allowing 3.3 V source-side termination and 5 V sink-side termination. The sink-side DDC ports are equipped with a rise time accelerator enabling drive of long cables or high bus capacitance. This enables the system designer to isolate bus capacitance to meet/exceed HDMI DDC specification. Furthermore, the DDC channel is augmented with an I²C-bus slave ROM device that provides optional HDMI dongle detect response, which can be enabled by dongle detect pin DDET. The PTN3363 offers back-power safe sink-side I/Os to disallow backdrive current from the DDC clock and data lines when power is off or when DDC is not enabled. An enable signal DCC_EN enables the DDC level shifter block.

Remark: When used in an HDMI dongle, the DDET function **must** be enabled for correct operation in accordance with DisplayPort interoperability guideline. When used in a DVI dongle, the DDET function **must** be disabled.

The PTN3363 also provides voltage translation for the Hot Plug Detect (HPD) signal from 0 V to 5 V on the sink side to 0 V to 3.3 V on the source side.

The PTN3363 does not retime any data. It contains no state machines. No inputs or outputs of the device are latched or clocked. Because the PTN3363 acts as a transparent level shifter, no reset is required.

Additional use case of PTN3363: PTN3363 can also be used in pure/native HDMI redriver applications wherein the input signal is already HDMI-compliant. In this application, the PTN3363 shall be connected as illustrated in [Figure 2](#). The AC coupling capacitors used are similar to that of DP++ use case.

7.1 Enable and disable features

PTN3363 offers different ways to enable or disable functionality, using the Output Enable (OE_N), and DDC Enable (DDC_EN) inputs. Whenever the PTN3363 is disabled (OE_N = HIGH **and** DDC_EN = LOW), the device is in Ultra low power mode and power consumption is ultra low; otherwise the PTN3363 is in active mode and power consumption depends on level of HPD_SINK signal. These two inputs each affect the operation of PTN3363 differently: OE_N controls the TMDS channels, DDC_EN controls only the DDC channel, and HPD_SINK is not affected by either of the control inputs. The following sections and truth table describe their detailed operation.

7.1.1 Hot plug detect

The HPD channel of PTN3363 functions as a level-shifting buffer to pass the HPD logic signal from the display sink device (via input HPD_SINK) on to the display source device (via output HPD_SOURCE). The HPD_SINK level is used to control the power state of the

PTN3363. If HPD_SINK is LOW, then PTN3363 is in standby mode. Once HPD_SINK goes HIGH, the PTN3363 can operate and its behavior is controlled further by other control pins — OE_N, DDC_EN, HIZ_EN.

The HPD channel operates independent of all these control signals.

HPD_SOURCE output follows the HPD_SINK input regardless of the power mode.

7.1.2 Output Enable function (OE_N)

When input OE_N is asserted (active LOW), the IN_Dx and OUT_Dx signals are fully functional. Input termination resistors are enabled and the internal bias circuits are turned on.

When OE_N is de-asserted (inactive HIGH), the OUT_Dx outputs are in a high-impedance state. The IN_Dx input buffers are disabled and IN_Dx termination is disabled. Power consumption is minimized.

Remark: Note that OE_N signal level has no influence on the HPD_SINK input, HPD_SOURCE output, or the SCL and SDA level shifters.

7.1.3 DDC channel enable function (DDC_EN)

The DDC_EN pin is active HIGH and can be used to isolate a badly behaved slave. When DDC_EN is LOW, the DDC channel is turned off. The DDC_EN input should never change state during an I²C-bus operation. Note that disabling DDC_EN during a bus operation may hang the bus, while enabling DDC_EN during bus traffic would corrupt the I²C-bus operation. Hence, DDC_EN should only be toggled while the bus is idle. The DDC channel enable (DDC_EN) and TMDS output enable (OE_N) can be controlled independent of each other.

7.1.4 TMDS high input impedance termination (HIZ_EN)

The HIZ_EN pin is an active HIGH input and it is used to provide high input impedance on the high-speed inputs (IN_Dx).

When HIZ_EN is LOW, 50 Ω termination resistors are enabled on IN_Dx and this configuration option is used for HDMI level shifter use case.

If HIZ_EN is HIGH, high input impedance is presented on IN_Dx and this configuration option is used when PTN3363 is used for native HDMI redriver use cases. In the native redriver use case, external 50 Ω termination resistors on the application are pulled up to V_{DD}.

7.1.5 Enable/disable truth table

Table 4. HPD_SINK, OE_N, HIZ_EN and DDC_EN enabling truth table

Inputs			Channels				Mode
HPD_SINK	OE_N	DDC_EN [1]	IN_Dx	OUT_Dx[2]	DDC[3]	HPD_SOURCE [4]	
LOW	LOW	LOW	high-Z	high-Z	high-Z	LOW	Standby
LOW	LOW	HIGH	high-Z	high-Z	high-Z	LOW	Standby
LOW	HIGH	LOW	high-Z	high-Z	high-Z	LOW	Ultra low power
LOW	HIGH	HIGH	high-Z	high-Z	high-Z	LOW	Standby
HIGH	LOW	LOW	50 Ω termination to $V_{RX(bias)}$ if HIZ_EN = LOW. >100 k Ω termination to $V_{RX(bias)}$ if HIZ_EN = HIGH.	outputs are enabled	high-Z	HIGH	Active; DDC disabled
HIGH	LOW	HIGH	50 Ω termination to $V_{RX(bias)}$ if HIZ_EN = LOW. >100 k Ω termination to $V_{RX(bias)}$ if HIZ_EN = HIGH.	outputs are enabled	SDA_SINK connected to SDA_SOURCE and SCL_SINK connected to SCL_SOURCE	HIGH	Active; DDC enabled
HIGH	HIGH	LOW	high-Z	high-Z	high-Z	HIGH	Ultra low power
HIGH	HIGH	HIGH	50 Ω termination to $V_{RX(bias)}$ if HIZ_EN = LOW. >100 k Ω termination to $V_{RX(bias)}$ if HIZ_EN = HIGH.	high-Z	SDA_SINK connected to SDA_SOURCE and SCL_SINK connected to SCL_SOURCE	HIGH	Standby; DDC enabled

[1] A LOW level on input DDC_EN disables only the DDC channel.

[2] OUT_Dx channels 'enabled' means outputs OUT_Dx toggling in accordance with IN_Dx differential input voltage switching.

[3] DDC channel 'enabled' means SDA_SINK is connected to SDA_SOURCE and SCL_SINK is connected to SCL_SOURCE.

[4] The HPD_SOURCE output logic state always follows the HPD_SINK input logic state.

7.2 Analog current reference

The REXT pin (pin 6) is an analog current sense port used to provide an accurate current reference for the differential outputs OUT_Dx. For best output voltage swing accuracy, use of a 12.4 k Ω resistor (1 % tolerance) connected between this terminal and GND is recommended.

If an external 12.4 k $\Omega \pm 1$ % resistor is not used, this pin can be connected to GND or V_{DD} directly (0 Ω). In any of these cases, the output functions normally but at reduced accuracy over voltage and temperature of the following parameters: output levels (V_{OL}), differential output voltage swing, and rise and fall time accuracy.

7.3 Equalizer

The PTN3363 supports four level equalization settings based on binary input pins EQ0 and EQ1.

Table 5. Equalizer settings

Inputs		Equalization for 3 Gbit/s
EQ1	EQ0	
short to GND	short to GND	0 dB
short to GND	short to V _{DD}	2 dB
short to V _{DD}	short to GND	4 dB
short to V _{DD}	short to V _{DD}	6 dB

7.4 Backdrive current protection

The PTN3363 is designed for backdrive protection on all sink-side TMDS outputs, sink-side DDC I/Os and the HPD_SINK input. This supports user scenarios where the display is connected and powered, but the PTN3363 is unpowered. In these cases, the PTN3363 sinks no more than a negligible amount of leakage current, and blocks the display (sink) termination network from driving the power supply of the PTN3363 or that of the inactive DVI or HDMI source or back into the V_{DD} power supply rail.

7.5 Squelch function

PTN3363 operates only when the input signal level is above certain minimum threshold (as per V_{RX_DIFFp-p}). If the input falls below that minimum threshold, the outputs are squelched.

7.6 Active DDC buffer with rise time accelerator

The PTN3363 DDC channel, besides providing 3.3 V to 5 V level shifting, includes active buffering and rise time acceleration for reliable DDC applications. While retaining all the operating modes and features of the I²C-bus system during the level shifts, it permits extension of the I²C-bus by providing bidirectional buffering for both the data (SDA) and the clock (SCL) line as well as the rise time accelerator on the sink-side port (SCL_SINK and SDA_SINK) enabling the bus to drive a load up to 1400 pF and 400 pF on the source-side port (SCL_SOURCE and SCA_SOURCE). Using the PTN3363 for DVI or HDMI level shifting enables the system designer to isolate bus capacitance to meet/exceed HDMI DDC specification. The SDA and SCL pins are overvoltage tolerant in high-impedance when the PTN3363 is unpowered or when DDC_EN is LOW.

PTN3363 has rise time accelerators on the sink-side port (SCL_SINK and SDA_SINK) only. During positive bus transitions on the sink-side port, a current source is switched on to quickly slew the SCL_SINK and SDA_SINK lines HIGH once the 5 V DDC bus V_{IL} threshold level of around 1.5 V is exceeded, and turns off as the 5 V DDC bus V_{IH} threshold voltage of approximately 3.5 V is approached.

7.7 I²C-bus based HDMI dongle detection

The PTN3363 includes an on-board I²C-bus slave ROM which provides a means to detect the presence of an HDMI dongle by the system through the DDC channel, accessible via ports SDA_SOURCE and SCL_SOURCE. This allows system vendors to detect HDMI

dongle presence through the already available DDC/I²C-bus port using a predetermined bus sequence. See [Section 8](#) for more information.

For the I²C-bus HDMI Dongle Detect function to be active, input pin DDET (dongle detect) should be tied HIGH. When DDET is LOW, the PTN3363 does not respond to an I²C-bus command. When used in an HDMI dongle, the DDET function **must** be enabled for correct operation in accordance with DisplayPort interoperability guideline. When used in a DVI dongle, the DDET function **must** be disabled.

The HDMI dongle detection is accomplished by accessing the PTN3363 on-board I²C-bus slave ROM using a simple sequential I²C-bus Read operation as described below.

7.7.1 Slave address



7.7.2 Read operation

The slave device address of PTN3363 is 80h¹. PTN3363 responds to a Read command to slave address 81h (PTN3363 responds with an ACK to a Write command to address 80h). Following the Read command, the PTN3363 responds with the contents of its internal ROM, as a sequence of 16 bytes, for as long as the master continues to issue clock edges with an acknowledge after each byte. The 16-byte sequence represents the 'DP-HDMI ADAPTOR<EOT>' symbol converted to ASCII and is documented in [Table 6](#).

The PTN3363 auto-increments its internal ROM address pointer (0x0 through 0x0F) as long as it continues to receive clock edges from the master with an acknowledge after each byte. If the master continues to issue clock edges past the 16th byte, the PTN3363 does not necessarily respond with 0xFF. If the master does not acknowledge a received byte, the PTN3363 internal address pointer is reset to 0 and a new Read sequence should be started by the master. Access to the 16-byte is by sequential read only as described above; there is no random-access possible to any specific byte in the ROM.

1. A 'dummy write' to subaddress 0x00 is required before the I²C-bus master can read the content of the internal ROM.

Table 6. DisplayPort - HDMI Adaptor Detection ROM content

Internal pointer offset (hexadecimal)	0	1	2	3	4	5	6	7	8	9	A	B	C	D	E	F
Data (hexadecimal)	44	50	2D	48	44	4D	49	20	41	44	41	50	54	4F	52	04

Table 7. HDMI dongle detect transaction sequence outline

Phase	I ² C transaction	Transmitting	Bit								Status		
			7	6	5	4	3	2	1	R/W	Master	Slave	
1	START	master									mandatory	-	
2	Write command	master	1	0	0	0	0	0	0	0	0	mandatory	-
3	Acknowledge	slave									-	mandatory	
4	Word address offset	master	word address offset data byte								mandatory	-	
5	Acknowledge	slave									-	mandatory	
6	STOP	master									optional	-	
7	START	master									mandatory	-	
8	Read command	master	1	0	0	0	0	0	0	0	1	mandatory	-
9	Acknowledge	slave									-	mandatory	
10	Read data	slave	data byte at offset 0								-	mandatory	
11	Acknowledge	master									mandatory	-	
12	Read data	slave	data byte at offset 1								-	mandatory	
13	:	:									-	-	
:	:	:									-	-	
40	Read data	slave	data byte at offset 15								-	mandatory	
41	Not Acknowledge	master									mandatory	-	
42	STOP	master									mandatory	-	

Remark: If the slave does not acknowledge the above transaction sequence, the entire sequence should be retried by the source.

7.8 Power management

PTN3363 implements innovative power management scheme whereby it achieves very low power consumption in both active and standby modes. Based on OE_N, DDC_EN, HPD_SNK, the PTN3363 intelligently optimizes the power consumption and disables outputs (OUT_Dx). Refer to [Table 8](#).

Table 8. Power management schemes

OE_N	DDC_EN	HPD_SINK	Source output	PTN3363 power mode
LOW	HIGH	HIGH	source active	Active mode; DDC active
LOW	HIGH	LOW	high-Z	Standby mode
HIGH	LOW	don't care	high-Z	Ultra low power mode

8. Application design-in information

8.1 Dongle or cable adaptor detect discovery mechanism

The PTN3363 supports the source-side dongle detect discovery mechanism described in *VESA DisplayPort Interoperability Guideline Version 1.1a*.

When a source-side cable adaptor is plugged into a multi-mode source device that supports multiple standards such as DisplayPort, DVI and HDMI, a discovery mechanism is needed for the multi-mode source to configure itself for outputting DisplayPort, DVI or HDMI-compliant signals through the dongle or cable adaptor. The discovery mechanism ensures that a multi-mode source device only sends either DVI or HDMI signals when a valid DVI or HDMI cable adaptor is present.

The *VESA Interoperability Guideline* recommends that a multi-mode source to power up with both DDC and AUX CH disabled. After initialization, the source device can use various mechanisms to decide whether a dongle or cable adaptor is present by detecting pin 13 on the DisplayPort connector. Depending on the voltage level detected at pin 13, the source configures itself either:

- as a DVI or HDMI source (see below paragraph for detection between DVI and HDMI), and enables DDC, while keeping AUX CH disabled, **or**
- as a DisplayPort source and enables AUX CH, while keeping DDC disabled.

The monitoring of the voltage level on pin 13 by a multi-mode source device is optional. A multi-mode source may also, for example, attempt an AUX CH read transaction and, if the transaction fails, a DDC transaction to discover the presence/absence of a cable adaptor.

Furthermore, a source that supports both DVI and HDMI can discover whether a DVI or HDMI dongle or cable adaptor is present by using various discovery procedures. One possible method is to check the voltage level of pin 14 of the DisplayPort connector. Pin 14 also carries CEC signal used for HDMI. Note that other HDMI devices on the CEC line may be momentarily pulling down pin 14 as a part of CEC protocol.

The *VESA Interoperability Guideline* recommends that a multi-mode source should distinguish a source-side HDMI cable adaptor from a DVI cable adaptor by checking the DDC buffer ID as described in [Section 7.7 “I²C-bus based HDMI dongle detection”](#). While it is optional for a multi-mode source to use the I²C-bus based HDMI dongle detection mechanism, it is mandatory for HDMI dongle or cable adaptor to respond to the I²C-bus read command. The PTN3363 provides an integrated I²C-bus slave ROM to support this mandatory HDMI dongle detect mechanism for HDMI dongles.

For a DisplayPort-to-HDMI source-side dongle or cable adaptor, DDET must be tied HIGH to enable the I²C-based HDMI dongle detection response function of PTN3363. For a DisplayPort-to-DVI sink-side dongle or cable adaptor, DDET must be tied LOW to disable the function.

9. Limiting values

Table 9. Limiting values

In accordance with the Absolute Maximum Rating System (IEC 60134).

Symbol	Parameter	Conditions	Min	Max	Unit
V _{DD}	supply voltage		-0.3	+4.6	V
V _I	input voltage	3.3 V CMOS inputs	-0.3	V _{DD} + 0.5	V
		5.0 V CMOS inputs	-0.3	6.0	V
T _{stg}	storage temperature		-65	+150	°C
V _{ESD}	electrostatic discharge voltage	HBM	[1] -	8000	V
		CDM	[2] -	1000	V

[1] Human Body Model: ANSI/ESDA/JEDEC JDS-001-2012 (Revision of ANSI/ESDA/JEDEC JS-001-2011), ESDA/JEDEC Joint standard for ESD sensitivity testing, Human Body Model - Component level; Electrostatic Discharge Association, Rome, NY, USA; JEDEC Solid State Technology Association, Arlington, VA, USA.

[2] Charged Device Model: JESD22-C101E December 2009 (Revision of JESD22-C101D, October 2008), standard for ESD sensitivity testing, Charged Device Model - Component level; JEDEC Solid State Technology Association, Arlington, VA, USA.

10. Recommended operating conditions

Table 10. Recommended operating conditions

Symbol	Parameter	Conditions	Min	Typ	Max	Unit
V _{DD}	supply voltage		2.8	3.3	3.6	V
V _I	input voltage	3.3 V CMOS inputs	0	-	3.6	V
		5.0 V CMOS inputs	0	-	5.5	V
V _{I(AV)}	average input voltage	IN_Dn+, IN_Dn- inputs	[1] -	0	-	V
R _{ref(ext)}	external reference resistance	connected between pin REXT (pin 4) and GND	[2] -	12.4 ± 1 %	-	kΩ
T _{amb}	ambient temperature	operating in free air	-40	-	+105	°C

[1] Input signals to these pins must be AC-coupled.

[2] Operation without external reference resistor is possible but results in reduced output voltage swing accuracy. For details, see [Section 7.2](#).

10.1 Current consumption

Table 11. Current consumption

Symbol	Parameter	Conditions	Min	Typ	Max	Unit
I _{DD}	supply current	OE_N = LOW; Active mode	-	22	-	mA
		OE_N = LOW; HPD_SINK = LOW; Standby mode	-	25	-	μA
		OE_N = HIGH, HPD_SINK = don't care and DDC_EN = LOW; Ultra low power mode	-	-	10	μA

11. Characteristics

11.1 Differential inputs

Table 12. Differential input characteristics for IN_Dx signals

Symbol	Parameter	Conditions	Min	Typ	Max	Unit
UI	unit interval ^[1]	nominal value at 3.4 Gbit/s	^[2] -	290	-	ps
		nominal value at 250 Mbit/s	^[2] -	4000	-	ps
$V_{RX_DIFFp-p}$	differential input peak-to-peak voltage		^[3] 0.15	-	1.2	V
t_{RX_EYE}	receiver eye time	minimum eye width at IN_Dx input pair	0.8	-	-	UI
$V_{i(cm)M(AC)}$	peak common-mode input voltage (AC)	includes all frequencies above 30 kHz	^[4] -	-	100	mV
Z_i	input impedance	DC input impedance				
		HIZ_EN = LOW	40	50	60	Ω
		HIZ_EN = HIGH	100	-	-	k Ω
$V_{RX(bias)}$	bias receiver voltage		1.0	1.8	1.95	V
$Z_{I(se)}$	single-ended input impedance	inputs in high-Z state	^[5] 100	-	-	k Ω
RL_{in}	input return loss	differential input; active mode; HIZ_EN = LOW				
		f = 100 MHz	-	-20	-	dB
		f = 1.5 GHz	-	-16	-	dB
		f = 3.4 GHz	-	-11	-	dB

[1] UI (unit interval) = t_{bit} (bit time).

[2] UI is determined by the display mode. Nominal bit rate ranges from 250 Mbit/s to 3.4 Gbit/s per lane.

[3] $V_{RX_DIFFp-p} = 2 \times |V_{RX_D+} - V_{RX_D-}|$. Applies to IN_Dx signals.

[4] $V_{i(cm)M(AC)} = |V_{RX_D+} + V_{RX_D-}| / 2 - V_{RX(cm)}$.
 $V_{RX(cm)} = DC (avg) \text{ of } |V_{RX_D+} + V_{RX_D-}| / 2$.

[5] Differential inputs switch to a high-impedance state when OE_N is HIGH.

11.2 Differential outputs

The level shifter’s differential outputs are designed to meet HDMI version 1.4b and DVI version 1.0 specifications.

Table 13. Differential output characteristics for OUT_Dx signals

Symbol	Parameter	Conditions	Min	Typ	Max	Unit
$V_{OH(se)}$	single-ended HIGH-level output voltage		[1] $V_{TT} - 0.01$	V_{TT}	$V_{TT} + 0.01$	V
$V_{OL(se)}$	single-ended LOW-level output voltage		[2] $V_{TT} - 0.60$	$V_{TT} - 0.50$	$V_{TT} - 0.40$	V
$\Delta V_{O(se)}$	single-ended output voltage variation	logic 1 and logic 0 state applied respectively to differential inputs IN_Dx; $R_{ref(ext)}$ connected; see Table 10	[3] 400	500	600	mV
I_{OZ}	OFF-state output current	single-ended	-	-	10	μ A
t_r	rise time	20 % to 80 %	75	-	150	ps
t_f	fall time	80 % to 20 %	75	-	150	ps
t_{sk}	skew time	intra-pair	[4] -	15	-	ps
		inter-pair	[5] -	-	250	ps
$t_{jit(add)}$	added jitter time	jitter contribution for TMDS signaling at 3.4 Gbit/s; PRBS7 pattern; EQ0 = LOW; EQ1 = LOW; refer to Figure 6	[6] -	13	-	ps

- [1] V_{TT} is the DC termination voltage in the HDMI or DVI sink. V_{TT} is nominally 3.3 V.
- [2] The open-drain output pulls down from V_{TT} .
- [3] Swing down from TMDS termination voltage ($3.3\text{ V} \pm 10\%$).
- [4] This differential skew budget is in addition to the skew presented between IN_D+ and IN_D- paired input pins.
- [5] This lane-to-lane skew budget is in addition to skew between differential input pairs.
- [6] Jitter budget for differential signals as they pass through the level shifter.

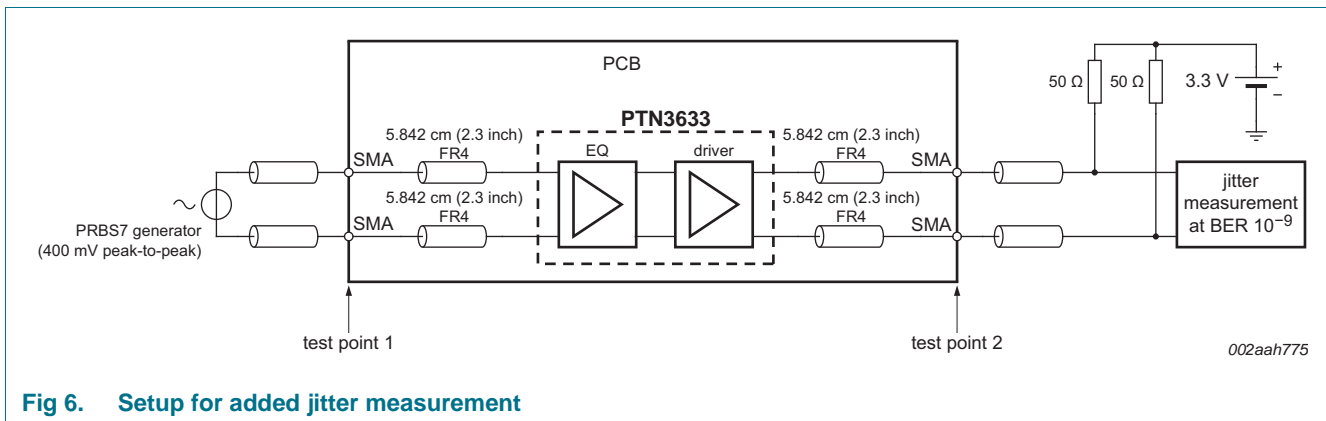

Fig 6. Setup for added jitter measurement

11.3 HPD_SINK input, HPD_SOURCE output

Table 14. HPD characteristics

Symbol	Parameter	Conditions	Min	Typ	Max	Unit
V _{IH}	HIGH-level input voltage	HPD_SINK	[1] 2.0	5.0	5.3	V
V _{IL}	LOW-level input voltage	HPD_SINK	0	-	0.8	V
I _{LI}	input leakage current	HPD_SINK	-	-	40	μA
V _{OH}	HIGH-level output voltage	HPD_SOURCE	2.5	-	V _{DD}	V
V _{OL}	LOW-level output voltage	HPD_SOURCE	0	-	0.2	V
t _{PD}	propagation delay	from HPD_SINK to HPD_SOURCE; 50 % to 50 %	[2] -	-	200	ns
t _t	transition time	HPD_SOURCE rise/fall; 10 % to 90 %	[3] 1	-	20	ns
R _{pd}	pull-down resistance	HPD_SINK input pull-down resistor	[4] 150	210	270	kΩ

[1] Low-speed input changes state on cable plug/unplug.

[2] Time from HPD_SINK changing state to HPD_SOURCE changing state. Includes HPD_SOURCE rise/fall time.

[3] Time required to transition from V_{OH} to V_{OL} or from V_{OL} to V_{OH}.

[4] Guarantees HPD_SINK is LOW when no display is plugged in.

11.4 OE_N, DDC_EN, HIZ_EN, EQ0, EQ1

Table 15. OE_N, DDC_EN input characteristics

Symbol	Parameter	Conditions	Min	Typ	Max	Unit
V _{IH}	HIGH-level input voltage		2.0	-		V
V _{IL}	LOW-level input voltage			-	0.8	V
I _{LI}	input leakage current	OE_N pin	[1] -	-	10	μA

[1] Measured with input at V_{IH} maximum and V_{IL} minimum.

11.5 DDC characteristics

Table 16. DDC characteristics

Symbol	Parameter	Conditions	Min	Typ	Max	Unit
Input and output SCL_SOURCE and SDA_SOURCE, $V_{CC1} = 2.8\text{ V to }3.6\text{ V}$ [1]						
V_{IH}	HIGH-level input voltage		$0.7 \times V_{CC1}$	-	3.6	V
V_{IL}	LOW-level input voltage		-0.5	-	+0.4	V
I_{LI}	input leakage current	$V_I = 3.6\text{ V}$	-	-	10	μA
I_{IL}	LOW-level input current	$V_I = 0.2\text{ V}$	-	-	10	μA
V_{OL}	LOW-level output voltage	$I_{OL} = 100\ \mu\text{A}$ or 6 mA	0.47	0.52	0.6	V
$V_{OL}-V_{IL}$	difference between LOW-level output and LOW-level input voltage	guaranteed by design to prevent contention	-	70	-	mV
C_{io}	input/output capacitance	$V_I = 3\text{ V}$ or 0 V ; $V_{DD} = 3.3\text{ V}$	-	6	7	pF
		$V_I = 3\text{ V}$ or 0 V ; $V_{DD} = 0\text{ V}$	-	6	7	pF
Input and output SDA_SINK and SCL_SINK, $V_{CC2} = 4.5\text{ V to }5.5\text{ V}$ [2]						
V_{IH}	HIGH-level input voltage		$0.7 \times V_{CC2}$	-	5.5	V
V_{IL}	LOW-level input voltage		-0.5	-	+1	V
I_{LI}	input leakage current	$V_I = 5.5\text{ V}$	-	-	10	μA
I_{IL}	LOW-level input current	$V_I = 0.2\text{ V}$	-	-	10	μA
V_{OL}	LOW-level output voltage	$I_{OL} = 6\text{ mA}$	-	0.1	0.2	V
C_{io}	input/output capacitance	$V_I = 3\text{ V}$ or 0 V ; $V_{DD} = 3.3\text{ V}$	-	-	7	pF
		$V_I = 3\text{ V}$ or 0 V ; $V_{DD} = 0\text{ V}$	-	6	7	pF
$I_{trt(pu)}$	transient boosted pull-up current	$V_{CC2} = 4.5\text{ V}$; slew rate = $1.25\text{ V}/\mu\text{s}$	-	4	-	mA

[1] V_{CC1} is the pull-up voltage for DDC source.

[2] V_{CC2} is the pull-up voltage for DDC sink.

12. Package outline

HVQFN32: plastic thermal enhanced very thin quad flat package; no leads;
32 terminals; body 5 x 5 x 0.85 mm

SOT617-3

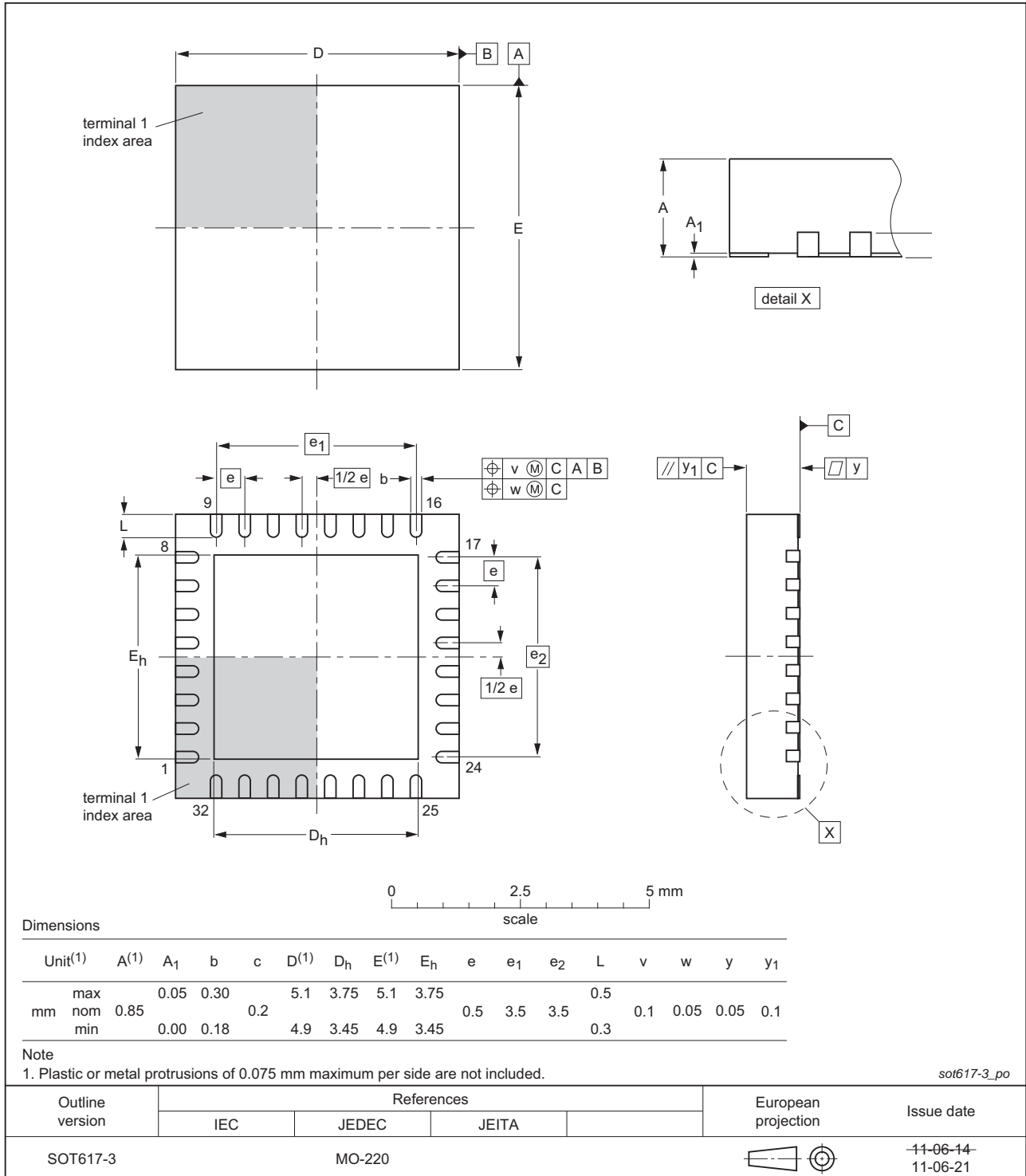

Fig 7. Package outline SOT617-3 (HVQFN32)

13. Soldering of SMD packages

This text provides a very brief insight into a complex technology. A more in-depth account of soldering ICs can be found in Application Note *AN10365 "Surface mount reflow soldering description"*.

13.1 Introduction to soldering

Soldering is one of the most common methods through which packages are attached to Printed Circuit Boards (PCBs), to form electrical circuits. The soldered joint provides both the mechanical and the electrical connection. There is no single soldering method that is ideal for all IC packages. Wave soldering is often preferred when through-hole and Surface Mount Devices (SMDs) are mixed on one printed wiring board; however, it is not suitable for fine pitch SMDs. Reflow soldering is ideal for the small pitches and high densities that come with increased miniaturization.

13.2 Wave and reflow soldering

Wave soldering is a joining technology in which the joints are made by solder coming from a standing wave of liquid solder. The wave soldering process is suitable for the following:

- Through-hole components
- Leaded or leadless SMDs, which are glued to the surface of the printed circuit board

Not all SMDs can be wave soldered. Packages with solder balls, and some leadless packages which have solder lands underneath the body, cannot be wave soldered. Also, leaded SMDs with leads having a pitch smaller than ~0.6 mm cannot be wave soldered, due to an increased probability of bridging.

The reflow soldering process involves applying solder paste to a board, followed by component placement and exposure to a temperature profile. Leaded packages, packages with solder balls, and leadless packages are all reflow solderable.

Key characteristics in both wave and reflow soldering are:

- Board specifications, including the board finish, solder masks and vias
- Package footprints, including solder thieves and orientation
- The moisture sensitivity level of the packages
- Package placement
- Inspection and repair
- Lead-free soldering versus SnPb soldering

13.3 Wave soldering

Key characteristics in wave soldering are:

- Process issues, such as application of adhesive and flux, clinching of leads, board transport, the solder wave parameters, and the time during which components are exposed to the wave
- Solder bath specifications, including temperature and impurities

13.4 Reflow soldering

Key characteristics in reflow soldering are:

- Lead-free versus SnPb soldering; note that a lead-free reflow process usually leads to higher minimum peak temperatures (see [Figure 8](#)) than a SnPb process, thus reducing the process window
- Solder paste printing issues including smearing, release, and adjusting the process window for a mix of large and small components on one board
- Reflow temperature profile; this profile includes preheat, reflow (in which the board is heated to the peak temperature) and cooling down. It is imperative that the peak temperature is high enough for the solder to make reliable solder joints (a solder paste characteristic). In addition, the peak temperature must be low enough that the packages and/or boards are not damaged. The peak temperature of the package depends on package thickness and volume and is classified in accordance with [Table 17](#) and [18](#)

Table 17. SnPb eutectic process (from J-STD-020D)

Package thickness (mm)	Package reflow temperature (°C)	
	Volume (mm ³)	
	< 350	≥ 350
< 2.5	235	220
≥ 2.5	220	220

Table 18. Lead-free process (from J-STD-020D)

Package thickness (mm)	Package reflow temperature (°C)		
	Volume (mm ³)		
	< 350	350 to 2000	> 2000
< 1.6	260	260	260
1.6 to 2.5	260	250	245
> 2.5	250	245	245

Moisture sensitivity precautions, as indicated on the packing, must be respected at all times.

Studies have shown that small packages reach higher temperatures during reflow soldering, see [Figure 8](#).

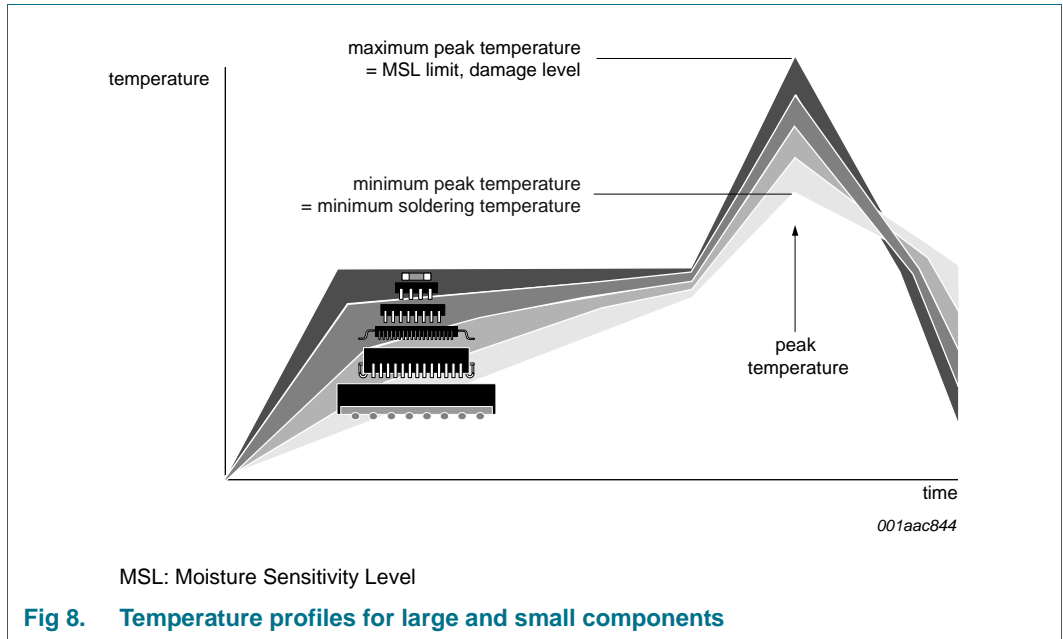

For further information on temperature profiles, refer to Application Note AN10365 “Surface mount reflow soldering description”.

14. Soldering: PCB footprints

Footprint information for reflow soldering of HVQFN32 package

SOT617-3

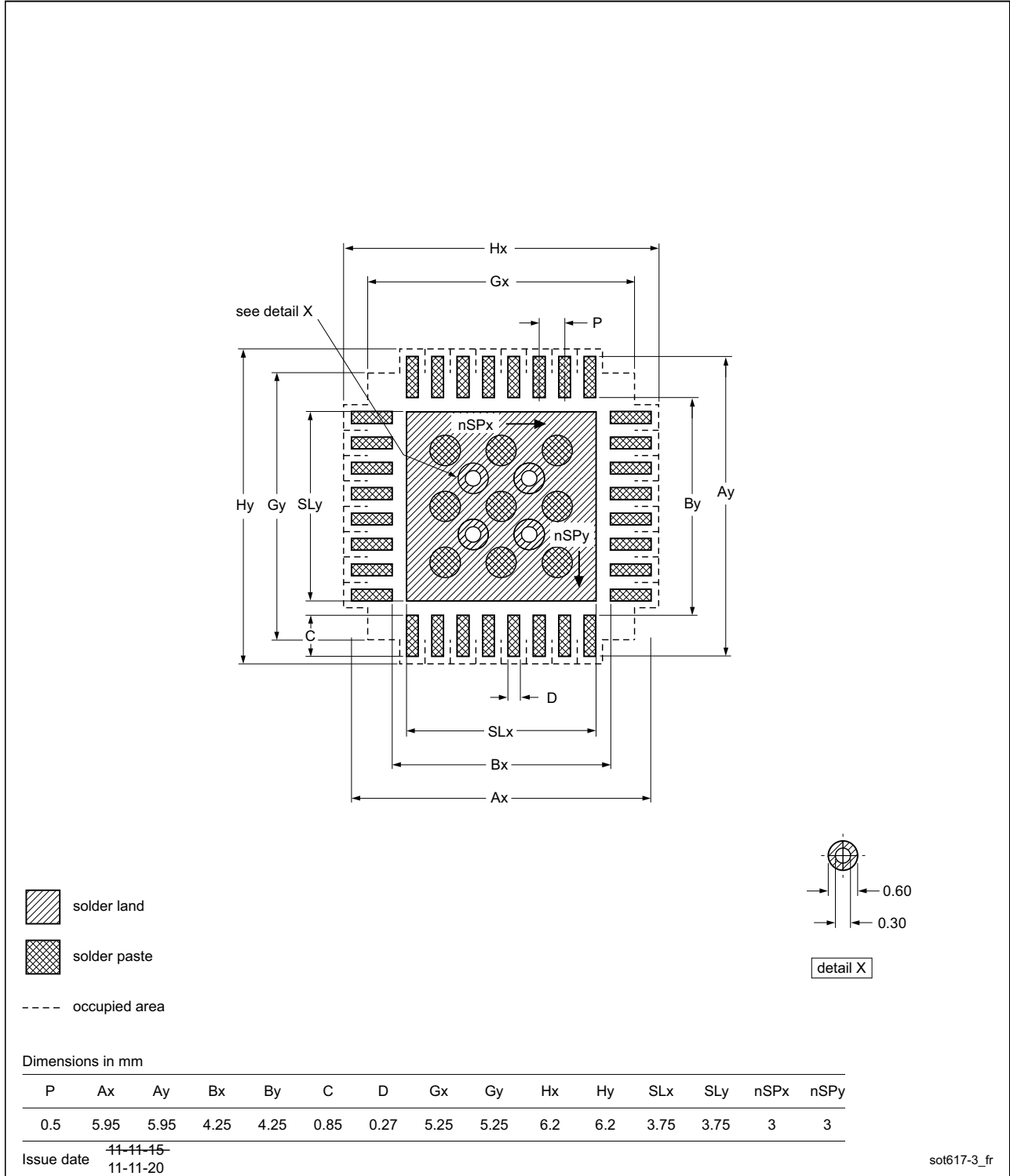

Fig 9. PCB footprint for SOT617-3 (HVQFN32); reflow soldering

15. Abbreviations

Table 19. Abbreviations

Acronym	Description
CDM	Charged-Device Model
CEC	Consumer Electronics Control
DDC	Data Display Channel
DP	Dry Pack
DVI	Digital Visual Interface
EMI	ElectroMagnetic Interference
ESD	ElectroStatic Discharge
HBM	Human Body Model
HDMI	High-Definition Multimedia Interface
HPD	Hot Plug Detect
I ² C-bus	Inter-IC bus
I/O	Input/Output
NMOS	Negative-channel Metal-Oxide Semiconductor
SMD	Surface Mount Device
TMDS	Transition Minimized Differential Signaling
VESA	Video Electronic Standards Association

16. Revision history

Table 20. Revision history

Document ID	Release date	Data sheet status	Change notice	Supersedes
PTN3363 v.1	20140812	Product data sheet	-	-

17. Legal information

17.1 Data sheet status

Document status ^{[1][2]}	Product status ^[3]	Definition
Objective [short] data sheet	Development	This document contains data from the objective specification for product development.
Preliminary [short] data sheet	Qualification	This document contains data from the preliminary specification.
Product [short] data sheet	Production	This document contains the product specification.

[1] Please consult the most recently issued document before initiating or completing a design.

[2] The term 'short data sheet' is explained in section "Definitions".

[3] The product status of device(s) described in this document may have changed since this document was published and may differ in case of multiple devices. The latest product status information is available on the Internet at URL <http://www.nxp.com>.

17.2 Definitions

Draft — The document is a draft version only. The content is still under internal review and subject to formal approval, which may result in modifications or additions. NXP Semiconductors does not give any representations or warranties as to the accuracy or completeness of information included herein and shall have no liability for the consequences of use of such information.

Short data sheet — A short data sheet is an extract from a full data sheet with the same product type number(s) and title. A short data sheet is intended for quick reference only and should not be relied upon to contain detailed and full information. For detailed and full information see the relevant full data sheet, which is available on request via the local NXP Semiconductors sales office. In case of any inconsistency or conflict with the short data sheet, the full data sheet shall prevail.

Product specification — The information and data provided in a Product data sheet shall define the specification of the product as agreed between NXP Semiconductors and its customer, unless NXP Semiconductors and customer have explicitly agreed otherwise in writing. In no event however, shall an agreement be valid in which the NXP Semiconductors product is deemed to offer functions and qualities beyond those described in the Product data sheet.

17.3 Disclaimers

Limited warranty and liability — Information in this document is believed to be accurate and reliable. However, NXP Semiconductors does not give any representations or warranties, expressed or implied, as to the accuracy or completeness of such information and shall have no liability for the consequences of use of such information. NXP Semiconductors takes no responsibility for the content in this document if provided by an information source outside of NXP Semiconductors.

In no event shall NXP Semiconductors be liable for any indirect, incidental, punitive, special or consequential damages (including - without limitation - lost profits, lost savings, business interruption, costs related to the removal or replacement of any products or rework charges) whether or not such damages are based on tort (including negligence), warranty, breach of contract or any other legal theory.

Notwithstanding any damages that customer might incur for any reason whatsoever, NXP Semiconductors' aggregate and cumulative liability towards customer for the products described herein shall be limited in accordance with the *Terms and conditions of commercial sale* of NXP Semiconductors.

Right to make changes — NXP Semiconductors reserves the right to make changes to information published in this document, including without limitation specifications and product descriptions, at any time and without notice. This document supersedes and replaces all information supplied prior to the publication hereof.

Suitability for use — NXP Semiconductors products are not designed, authorized or warranted to be suitable for use in life support, life-critical or safety-critical systems or equipment, nor in applications where failure or malfunction of an NXP Semiconductors product can reasonably be expected to result in personal injury, death or severe property or environmental damage. NXP Semiconductors and its suppliers accept no liability for inclusion and/or use of NXP Semiconductors products in such equipment or applications and therefore such inclusion and/or use is at the customer's own risk.

Applications — Applications that are described herein for any of these products are for illustrative purposes only. NXP Semiconductors makes no representation or warranty that such applications will be suitable for the specified use without further testing or modification.

Customers are responsible for the design and operation of their applications and products using NXP Semiconductors products, and NXP Semiconductors accepts no liability for any assistance with applications or customer product design. It is customer's sole responsibility to determine whether the NXP Semiconductors product is suitable and fit for the customer's applications and products planned, as well as for the planned application and use of customer's third party customer(s). Customers should provide appropriate design and operating safeguards to minimize the risks associated with their applications and products.

NXP Semiconductors does not accept any liability related to any default, damage, costs or problem which is based on any weakness or default in the customer's applications or products, or the application or use by customer's third party customer(s). Customer is responsible for doing all necessary testing for the customer's applications and products using NXP Semiconductors products in order to avoid a default of the applications and the products or of the application or use by customer's third party customer(s). NXP does not accept any liability in this respect.

Limiting values — Stress above one or more limiting values (as defined in the Absolute Maximum Ratings System of IEC 60134) will cause permanent damage to the device. Limiting values are stress ratings only and (proper) operation of the device at these or any other conditions above those given in the Recommended operating conditions section (if present) or the Characteristics sections of this document is not warranted. Constant or repeated exposure to limiting values will permanently and irreversibly affect the quality and reliability of the device.

Terms and conditions of commercial sale — NXP Semiconductors products are sold subject to the general terms and conditions of commercial sale, as published at <http://www.nxp.com/profile/terms>, unless otherwise agreed in a valid written individual agreement. In case an individual agreement is concluded only the terms and conditions of the respective agreement shall apply. NXP Semiconductors hereby expressly objects to applying the customer's general terms and conditions with regard to the purchase of NXP Semiconductors products by customer.

No offer to sell or license — Nothing in this document may be interpreted or construed as an offer to sell products that is open for acceptance or the grant, conveyance or implication of any license under any copyrights, patents or other industrial or intellectual property rights.

Export control — This document as well as the item(s) described herein may be subject to export control regulations. Export might require a prior authorization from competent authorities.

Non-automotive qualified products — Unless this data sheet expressly states that this specific NXP Semiconductors product is automotive qualified, the product is not suitable for automotive use. It is neither qualified nor tested in accordance with automotive testing or application requirements. NXP Semiconductors accepts no liability for inclusion and/or use of non-automotive qualified products in automotive equipment or applications.

In the event that customer uses the product for design-in and use in automotive applications to automotive specifications and standards, customer (a) shall use the product without NXP Semiconductors' warranty of the product for such automotive applications, use and specifications, and (b) whenever customer uses the product for automotive applications beyond NXP Semiconductors' specifications such use shall be solely at customer's own risk, and (c) customer fully indemnifies NXP Semiconductors for any liability, damages or failed product claims resulting from customer design and use of the product for automotive applications beyond NXP Semiconductors' standard warranty and NXP Semiconductors' product specifications.

Translations — A non-English (translated) version of a document is for reference only. The English version shall prevail in case of any discrepancy between the translated and English versions.

17.4 Licenses

Purchase of NXP ICs with HDMI technology

Use of an NXP IC with HDMI technology in equipment that complies with the HDMI standard requires a license from HDMI Licensing LLC, 1060 E. Arques Avenue Suite 100, Sunnyvale CA 94085, USA, e-mail: admin@hdmi.org.

17.5 Trademarks

Notice: All referenced brands, product names, service names and trademarks are the property of their respective owners.

18. Contact information

For more information, please visit: <http://www.nxp.com>

For sales office addresses, please send an email to: salesaddresses@nxp.com



19. Contents

1	General description	1	13.1	Introduction to soldering	23
2	Features and benefits	4	13.2	Wave and reflow soldering	23
2.1	High-speed TMDS level shifting	4	13.3	Wave soldering	23
2.2	DDC level shifting	4	13.4	Reflow soldering	24
2.3	HPD level shifting	4	14	Soldering: PCB footprints	26
2.4	HDMI dongle detection support	4	15	Abbreviations	27
2.5	General	4	16	Revision history	27
3	Applications	5	17	Legal information	28
4	Ordering information	5	17.1	Data sheet status	28
4.1	Ordering options	5	17.2	Definitions	28
5	Functional diagram	6	17.3	Disclaimers	28
6	Pinning information	7	17.4	Licenses	29
6.1	Pinning	7	17.5	Trademarks	29
6.2	Pin description	7	18	Contact information	29
7	Functional description	10	19	Contents	30
7.1	Enable and disable features	10			
7.1.1	Hot plug detect	10			
7.1.2	Output Enable function (OE_N)	11			
7.1.3	DDC channel enable function (DDC_EN)	11			
7.1.4	TMDS high input impedance termination (HIZ_EN)	11			
7.1.5	Enable/disable truth table	12			
7.2	Analog current reference	12			
7.3	Equalizer	13			
7.4	Backdrive current protection	13			
7.5	Squelch function	13			
7.6	Active DDC buffer with rise time accelerator	13			
7.7	I ² C-bus based HDMI dongle detection	14			
7.7.1	Slave address	14			
7.7.2	Read operation	14			
7.8	Power management	15			
8	Application design-in information	16			
8.1	Dongle or cable adaptor detect discovery mechanism	16			
9	Limiting values	17			
10	Recommended operating conditions	17			
10.1	Current consumption	17			
11	Characteristics	18			
11.1	Differential inputs	18			
11.2	Differential outputs	19			
11.3	HPD_SINK input, HPD_SOURCE output	20			
11.4	OE_N, DDC_EN, HIZ_EN, EQ0, EQ1	20			
11.5	DDC characteristics	21			
12	Package outline	22			
13	Soldering of SMD packages	23			

Please be aware that important notices concerning this document and the product(s) described herein, have been included in section 'Legal information'.

Looking for pricing, stock, or lifecycle information?

Click below to explore more details on WIN SOURCE:

-  [View PTN3363BSMP on WIN SOURCE](#)
-  [NXP / Nexperia Information](#)

Optimize Your Supply Chain with WIN SOURCE Solutions

-  Global Sourcing Solution
-  Obsolete Management
-  Cost Control Management
-  Shortage Management
-  Alternative Solution
-  Excess Inventory Management