

CDCVF111 1:9 DIFFERENTIAL LVPECL CLOCK DRIVER

SCAS670B – SEPTEMBER 2001 – REVISED JUNE 2002

- Low-Output Skew for Clock-Distribution Applications
- Differential Low-Voltage Pseudo-ECL (LVPECL) Compatible Inputs and Outputs
- Distributes Differential Clock Inputs to Nine Differential Clock Outputs
- Output Reference Voltage (V_{REF}) Allows Distribution From a Single-Ended Clock Input
- Packaged In a 28-Pin Plastic Chip Carrier

description

The differential LVPECL clock-driver circuit distributes one pair of differential LVPECL clock inputs (\overline{CLKIN} , $CLKIN$) to nine pairs of differential clock (Y , \overline{Y}) outputs with minimum skew for clock distribution. It is specifically designed for driving 50- Ω transmission lines.

The V_{REF} output can be strapped to the \overline{CLKIN} input for a single-ended $CLKIN$ input.

The CDCVF111 is characterized for operation from -40°C to 85°C .

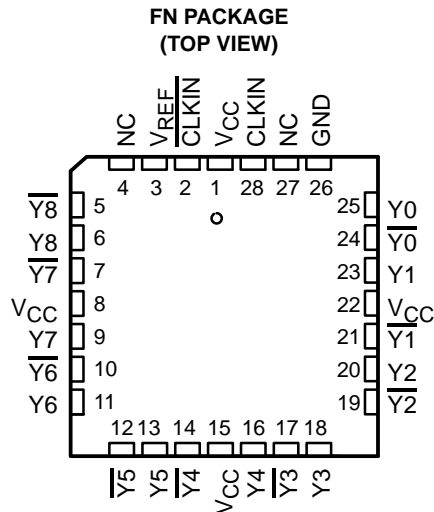

NC – No internal connection

FUNCTION TABLE

INPUTS		OUTPUTS	
$CLKIN$	\overline{CLKIN}	Y_n	\overline{Y}_n
X	X	L	H
L	H	L	H
H	L	H	L
L	V_{REF}	L	H
H	V_{REF}	H	L
V_{REF}	L	H	L
V_{REF}	H	L	H



Please be aware that an important notice concerning availability, standard warranty, and use in critical applications of Texas Instruments semiconductor products and disclaimers thereto appears at the end of this data sheet.

PRODUCTION DATA information is current as of publication date. Products conform to specifications per the terms of Texas Instruments standard warranty. Production processing does not necessarily include testing of all parameters.

 **TEXAS
INSTRUMENTS**

POST OFFICE BOX 655303 • DALLAS, TEXAS 75265

Copyright © 2002, Texas Instruments Incorporated

CDCVF111

1:9 DIFFERENTIAL LVPECL CLOCK DRIVER

SCAS670B – SEPTEMBER 2001 – REVISED JUNE 2002

logic diagram (positive logic)

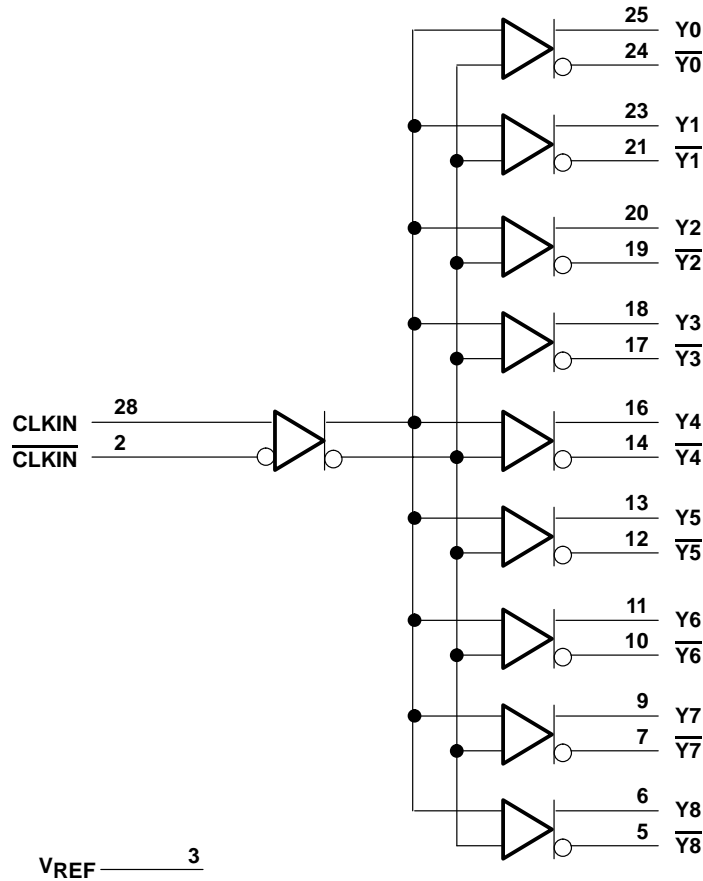

absolute maximum ratings over operating free-air temperature range (unless otherwise noted)[†]

Supply voltage range, V_{CC}	-0.5 V to 4.6 V
Input voltage range, V_I (see Note 1)	-0.5 V to $V_{CC} + 0.5$ V
Output voltage range, V_O (see Note 1)	-0.5 V to $V_{CC} + 0.5$ V
Input clamp current, I_{IK} ($V_I < 0$)	-18 mA
Output clamp current, I_{OK} ($V_O < 0$ or $V_O > V_{CC}$)	-18 mA
Continuous output current, I_O ($V_O = 0$ to V_{CC})	-50 mA
Continuous current through V_{CC} or GND	± 80 mA
Maximum power dissipation at $T_A = 55^\circ\text{C}$ (in still air) (see Note 2)	525 mW
Storage temperature range, T_{stg}	-65°C to 150°C

[†] Stresses beyond those listed under "absolute maximum ratings" may cause permanent damage to the device. These are stress ratings only, and functional operation of the device at these or any other conditions beyond those indicated under "recommended operating conditions" is not implied. Exposure to absolute-maximum-rated conditions for extended periods may affect device reliability.

- NOTES: 1. The input and output negative-voltage ratings may be exceeded if the input and output clamp-current ratings are observed.
 2. The maximum package power dissipation is calculated using a junction temperature of 150°C and a board trace length of 750 mils. For more information, refer to the *Package Thermal Considerations* application note in the *ABT Advanced BiCMOS Technology Data Book*, literature number SCBD002.



CDCVF111 1:9 DIFFERENTIAL LVPECL CLOCK DRIVER

SCAS670B – SEPTEMBER 2001 – REVISED JUNE 2002

recommended operating conditions

		MIN	MAX	UNIT	
V_{CC}	Supply voltage	3	3.6	V	
V_{IH}	High-level input voltage	$V_{CC} = 3\text{ V to }3.6\text{ V}$	$V_{CC}-1.165$	$V_{CC}-0.88$	V
		$V_{CC} = 3.3\text{ V}$	2.135	2.42	V
V_{IL}	Low-level input voltage	$V_{CC} = 3\text{ V to }3.6\text{ V}$	$V_{CC}-1.81$	$V_{CC}-1.475$	V
		$V_{CC} = 3.3\text{ V}$	1.49	1.825	V
T_A	Operating free-air temperature	-40	85	°C	
f_{clock}	Input frequency		650	MHz	

electrical characteristics over recommended operating free-air temperature range (unless otherwise noted)

PARAMETER	TEST CONDITIONS		MIN	MAX	UNIT
V_{REF}	$V_{CC} = 3\text{ V to }3.6\text{ V}$	$I_{REF} = 100\ \mu\text{A}$	$V_{CC}-1.38$	$V_{CC}-1.26$	V
	$V_{CC} = 3.3\text{ V}$		1.92	2.04	
V_{OH}	$V_{CC} = 3\text{ V to }3.6\text{ V}$, $T_A = 0^\circ\text{C to }85^\circ\text{C}$, $f_{(max)} = 650\text{ MHz}$		$V_{CC}-1.12$	$V_{CC}-0.83$	V
	$V_{CC} = 3\text{ V to }3.6\text{ V}$, $T_A = -40^\circ\text{C to }85^\circ\text{C}$, $f_{(max)} = 650\text{ MHz}$		$V_{CC}-1.15$	$V_{CC}-0.83$	
	$V_{CC} = 3.3\text{ V}$		2.275	2.42	
V_{OL}	$V_{CC} = 3\text{ V to }3.6\text{ V}$, $T_A = 0^\circ\text{C to }85^\circ\text{C}$, $f_{(max)} = 650\text{ MHz}$		$V_{CC}-1.86$	$V_{CC}-1.49$	V
	$V_{CC} = 3\text{ V to }3.6\text{ V}$, $T_A = -40^\circ\text{C to }85^\circ\text{C}$, $f_{(max)} = 650\text{ MHz}$		$V_{CC}-1.86$	$V_{CC}-1.52$	
	$V_{CC} = 3.3\text{ V}$		1.49	1.68	
I_I	$V_I = 2.4\text{ V}$,	$V_{CC} = 3.6\text{ V}$		150	μA
I_{CC} (Internal)	$I_O = 0$,	$V_{CC} = 3.6\text{ V}$		100	mA

switching characteristics over recommended operating free-air temperature range, $V_{CC} = 3.3\text{ V} \pm 0.3\text{ V}$ (see Figure 1 and Figure 2)

PARAMETER	FROM (INPUT)	TO (OUTPUT)	MIN	MAX	UNIT
t_{PLH}	CLKIN, $\overline{\text{CLKIN}}$	Y, \overline{Y}	450	600	ps
t_{PHL}					
$t_{sk(o)}$		Y, \overline{Y}		50	ps
$t_{sk(pr)}$		Y, \overline{Y}		150	ps
t_r		Y, \overline{Y}	200	600	ps
t_f					

CDCVF111

1:9 DIFFERENTIAL LVPECL CLOCK DRIVER

SCAS670B – SEPTEMBER 2001 – REVISED JUNE 2002

ESD information

ESD MODELS	LIMIT
Human Body Model (HBM)	2.0 kV
Machine Model (MM)	200 V
Charge Device Model (CDM)	2.0 kV

thermal information

CDCVF111 28-PIN PLCC		THERMAL AIR FLOW (CFM)				UNIT
		0	150	250	500	
R θ JA	High K	48	44	42	39	°C/W
R θ JA	Low K	70	58	52	46	°C/W
R θ JC	High K	22				°C/W
R θ JC	Low K	28				°C/W

PARAMETER MEASUREMENT INFORMATION

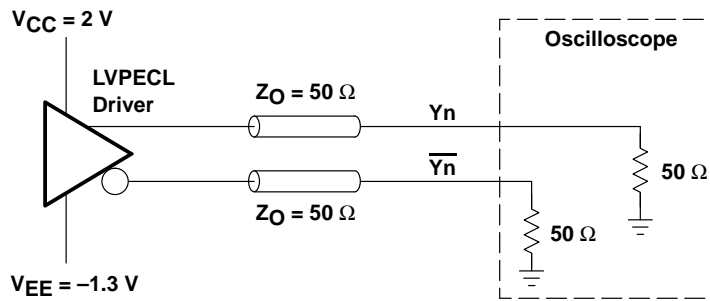

LOAD CIRCUIT (See Note B)

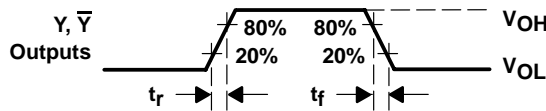

VOLTAGE WAVEFORMS
RISE AND FALL TIMES

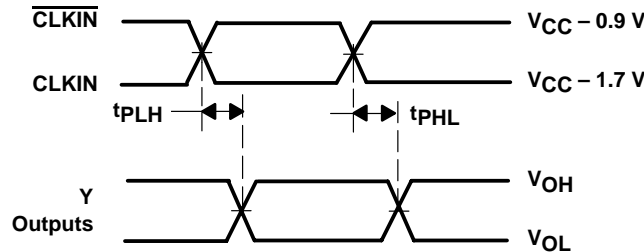

VOLTAGE WAVEFORMS
PROPAGATION DELAY TIMES

- NOTES: A. All input pulses are supplied by generators having the following characteristics: PRR \leq 45 MHz, $Z_O = 50 \Omega$, $t_r \leq 1$ ns, $t_f \leq 1$ ns.
 B. For additional signal interface, see the *Interfacing Between LVPECL, LVDS, and CML* application note, Literature Number SCAA056.

Figure 1. Load Circuit and Voltage Waveforms

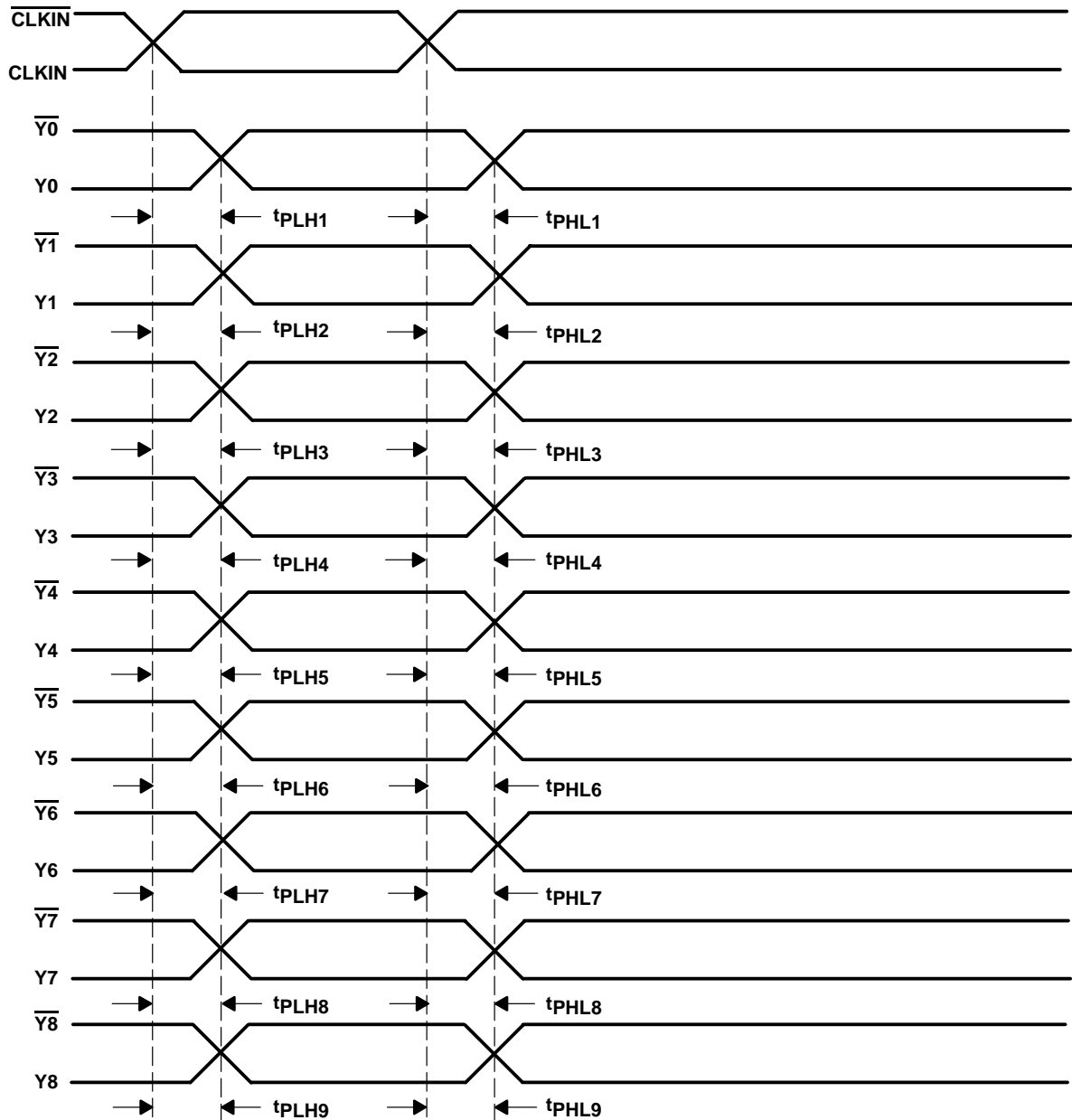

- NOTES: A. Output skew, $t_{sk(o)}$, is calculated as the greater of:
- The difference between the fastest and slowest t_{PLHn} ($n = 1, 2, \dots, 9$)
 - The difference between the fastest and slowest t_{PHLn} ($n = 1, 2, \dots, 9$)
- B. Process skew, $t_{sk(pr)}$, is calculated as the greater of:
- The difference between the fastest and slowest t_{PLHn} ($n = 1, 2, \dots, 9$)
 - The difference between the fastest and slowest t_{PHLn} ($n = 1, 2, \dots, 9$) across multiple devices
- C. For additional information on skew and propagation delay parameters, see the *Defining Skew, Propagation Delay, Phase-Offset (Phase Error)* application note, literature number SCAA055.

Figure 2. Waveforms for Calculation of $t_{sk(o)}$, $t_{sk(pr)}$

PACKAGING INFORMATION

Orderable Device	Status (1)	Package Type	Package Drawing	Pins	Package Qty	Eco Plan (2)	Lead/Ball Finish	MSL Peak Temp (3)	Op Temp (°C)	Top-Side Markings (4)	Samples
CDCVF111FN	ACTIVE	PLCC	FN	28	37	Green (RoHS & no Sb/Br)	CU NIPDAU	Level-1-260C-UNLIM	-40 to 85	CDCVF111	Samples
CDCVF111FNG4	ACTIVE	PLCC	FN	28	37	Green (RoHS & no Sb/Br)	CU NIPDAU	Level-1-260C-UNLIM	-40 to 85	CDCVF111	Samples
CDCVF111FNR	ACTIVE	PLCC	FN	28	750	Green (RoHS & no Sb/Br)	CU NIPDAU	Level-1-260C-UNLIM	-40 to 85	CDCVF111	Samples
CDCVF111FNRG4	ACTIVE	PLCC	FN	28	750	Green (RoHS & no Sb/Br)	CU NIPDAU	Level-1-260C-UNLIM	-40 to 85	CDCVF111	Samples

(1) The marketing status values are defined as follows:

ACTIVE: Product device recommended for new designs.

LIFEBUY: TI has announced that the device will be discontinued, and a lifetime-buy period is in effect.

NRND: Not recommended for new designs. Device is in production to support existing customers, but TI does not recommend using this part in a new design.

PREVIEW: Device has been announced but is not in production. Samples may or may not be available.

OBSELETE: TI has discontinued the production of the device.

(2) Eco Plan - The planned eco-friendly classification: Pb-Free (RoHS), Pb-Free (RoHS Exempt), or Green (RoHS & no Sb/Br) - please check <http://www.ti.com/productcontent> for the latest availability information and additional product content details.

TBD: The Pb-Free/Green conversion plan has not been defined.

Pb-Free (RoHS): TI's terms "Lead-Free" or "Pb-Free" mean semiconductor products that are compatible with the current RoHS requirements for all 6 substances, including the requirement that lead not exceed 0.1% by weight in homogeneous materials. Where designed to be soldered at high temperatures, TI Pb-Free products are suitable for use in specified lead-free processes.

Pb-Free (RoHS Exempt): This component has a RoHS exemption for either 1) lead-based flip-chip solder bumps used between the die and package, or 2) lead-based die adhesive used between the die and leadframe. The component is otherwise considered Pb-Free (RoHS compatible) as defined above.

Green (RoHS & no Sb/Br): TI defines "Green" to mean Pb-Free (RoHS compatible), and free of Bromine (Br) and Antimony (Sb) based flame retardants (Br or Sb do not exceed 0.1% by weight in homogeneous material)

(3) MSL, Peak Temp. -- The Moisture Sensitivity Level rating according to the JEDEC industry standard classifications, and peak solder temperature.

(4) Multiple Top-Side Markings will be inside parentheses. Only one Top-Side Marking contained in parentheses and separated by a "~" will appear on a device. If a line is indented then it is a continuation of the previous line and the two combined represent the entire Top-Side Marking for that device.

Important Information and Disclaimer: The information provided on this page represents TI's knowledge and belief as of the date that it is provided. TI bases its knowledge and belief on information provided by third parties, and makes no representation or warranty as to the accuracy of such information. Efforts are underway to better integrate information from third parties. TI has taken and continues to take reasonable steps to provide representative and accurate information but may not have conducted destructive testing or chemical analysis on incoming materials and chemicals. TI and TI suppliers consider certain information to be proprietary, and thus CAS numbers and other limited information may not be available for release.

In no event shall TI's liability arising out of such information exceed the total purchase price of the TI part(s) at issue in this document sold by TI to Customer on an annual basis.

TAPE AND REEL INFORMATION

QUADRANT ASSIGNMENTS FOR PIN 1 ORIENTATION IN TAPE

*All dimensions are nominal

Device	Package Type	Package Drawing	Pins	SPQ	Reel Diameter (mm)	Reel Width W1 (mm)	A0 (mm)	B0 (mm)	K0 (mm)	P1 (mm)	W (mm)	Pin1 Quadrant
CDCVF111FNR	PLCC	FN	28	750	330.0	24.4	12.95	12.95	5.0	16.0	24.0	Q1

TAPE AND REEL BOX DIMENSIONS



*All dimensions are nominal

Device	Package Type	Package Drawing	Pins	SPQ	Length (mm)	Width (mm)	Height (mm)
CDCVF111FNR	PLCC	FN	28	750	346.0	346.0	41.0

FN 28

GENERIC PACKAGE VIEW
PLCC - 4.57 mm max height
PLASTIC CHIP CARRIER



Images above are just a representation of the package family, actual package may vary.
Refer to the product data sheet for package details.

4040005-3/C



PACKAGE OUTLINE

FN0028A

PLCC - 4.57 mm max height

PLASTIC CHIP CARRIER

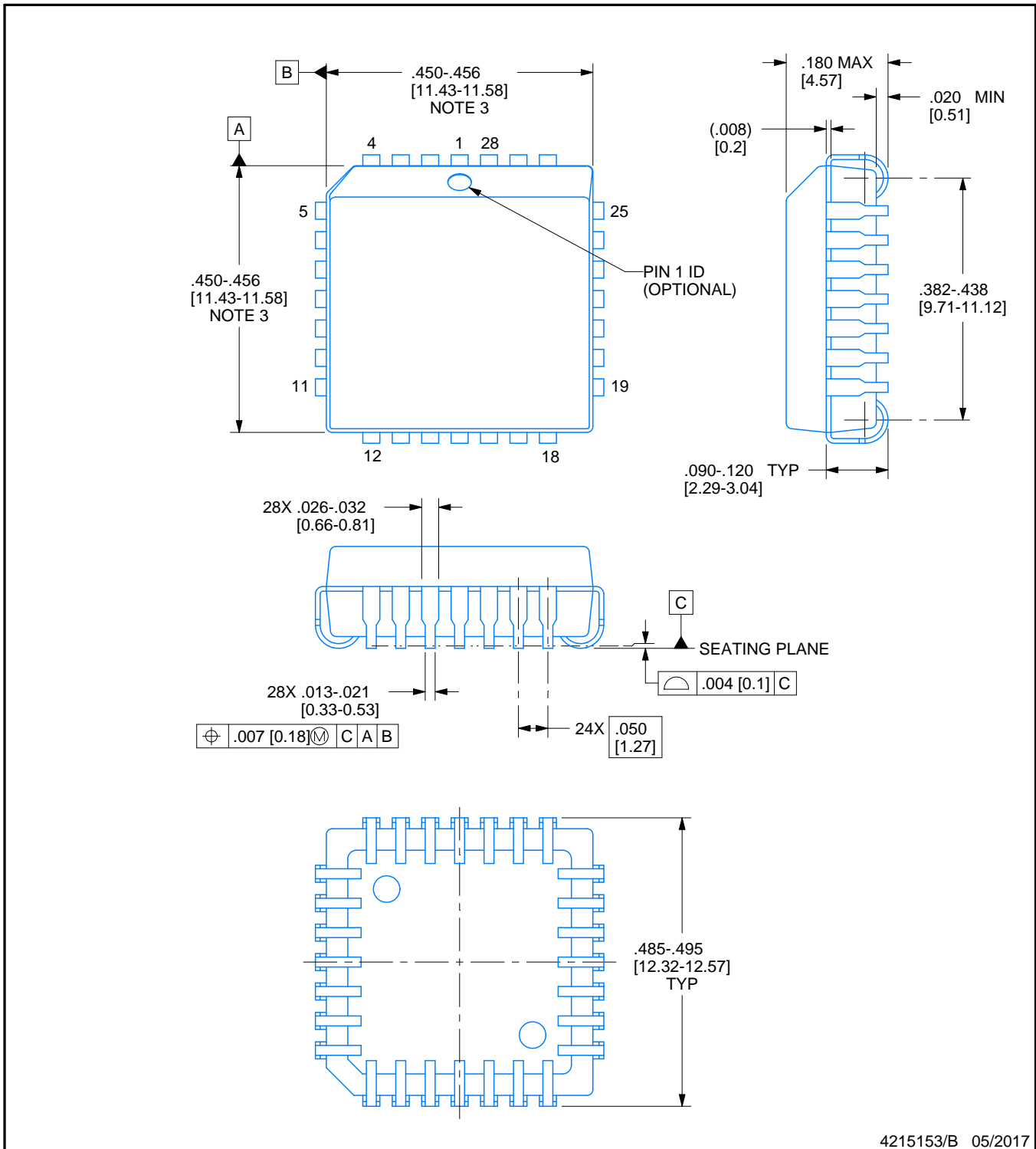

4215153/B 05/2017

NOTES:

1. All linear dimensions are in inches. Any dimensions in brackets are in millimeters. Any dimensions in parenthesis are for reference only. Controlling dimensions are in inches. Dimensioning and tolerancing per ASME Y14.5M.
2. This drawing is subject to change without notice.
3. Dimension does not include mold protrusion. Maximum allowable mold protrusion .01 in [0.25 mm] per side.
4. Reference JEDEC registration MS-018.

EXAMPLE BOARD LAYOUT

FN0028A

PLCC - 4.57 mm max height

PLASTIC CHIP CARRIER

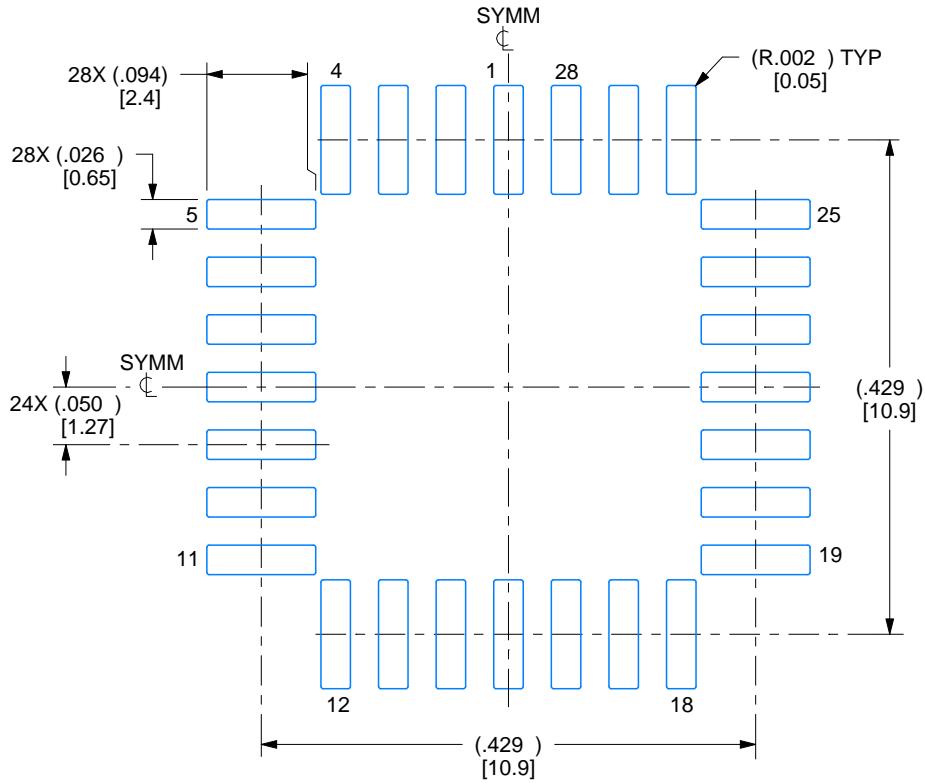

LAND PATTERN EXAMPLE
EXPOSED METAL SHOWN
SCALE:6X

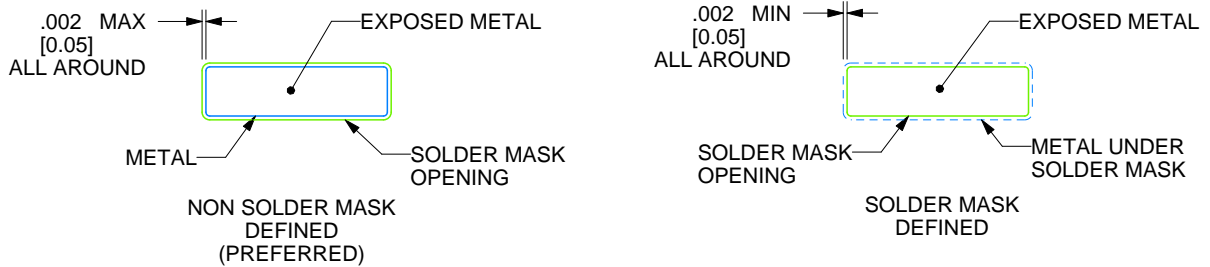

SOLDER MASK DETAILS

4215153/B 05/2017

NOTES: (continued)

- 5. Publication IPC-7351 may have alternate designs.
- 6. Solder mask tolerances between and around signal pads can vary based on board fabrication site.

EXAMPLE STENCIL DESIGN

FN0028A

PLCC - 4.57 mm max height

PLASTIC CHIP CARRIER

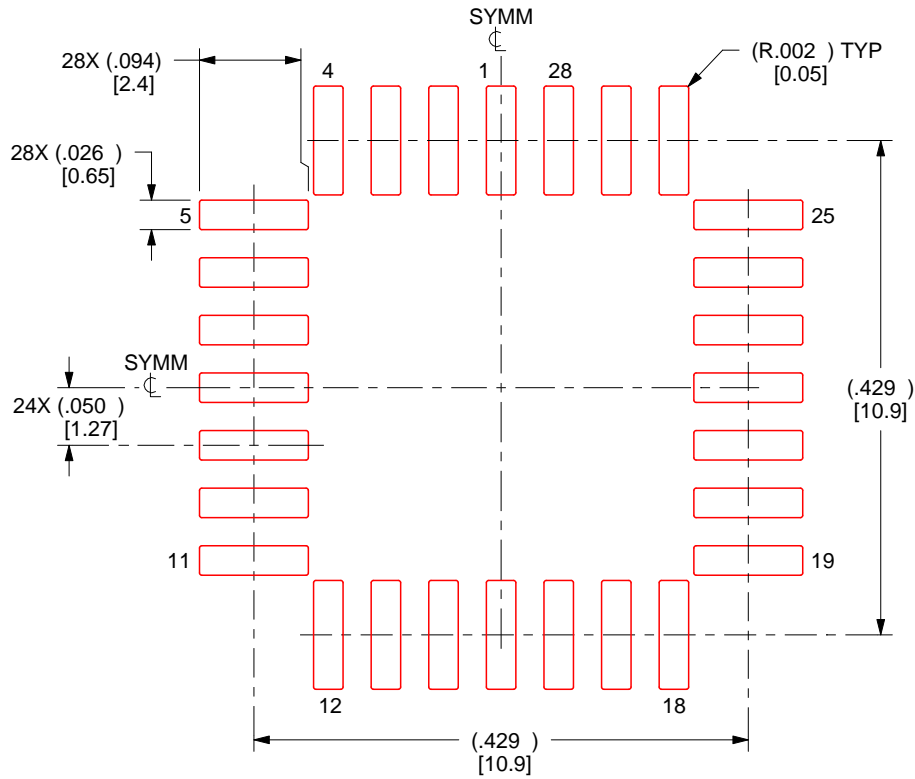

SOLDER PASTE EXAMPLE
BASED ON 0.125 mm THICK STENCIL
SCALE:6X

4215153/B 05/2017

NOTES: (continued)

7. Laser cutting apertures with trapezoidal walls and rounded corners may offer better paste release. IPC-7525 may have alternate design recommendations.
8. Board assembly site may have different recommendations for stencil design.

IMPORTANT NOTICE

Texas Instruments Incorporated (TI) reserves the right to make corrections, enhancements, improvements and other changes to its semiconductor products and services per JESD46, latest issue, and to discontinue any product or service per JESD48, latest issue. Buyers should obtain the latest relevant information before placing orders and should verify that such information is current and complete.

TI's published terms of sale for semiconductor products (<http://www.ti.com/sc/docs/stdterms.htm>) apply to the sale of packaged integrated circuit products that TI has qualified and released to market. Additional terms may apply to the use or sale of other types of TI products and services.

Reproduction of significant portions of TI information in TI data sheets is permissible only if reproduction is without alteration and is accompanied by all associated warranties, conditions, limitations, and notices. TI is not responsible or liable for such reproduced documentation. Information of third parties may be subject to additional restrictions. Resale of TI products or services with statements different from or beyond the parameters stated by TI for that product or service voids all express and any implied warranties for the associated TI product or service and is an unfair and deceptive business practice. TI is not responsible or liable for any such statements.

Buyers and others who are developing systems that incorporate TI products (collectively, "Designers") understand and agree that Designers remain responsible for using their independent analysis, evaluation and judgment in designing their applications and that Designers have full and exclusive responsibility to assure the safety of Designers' applications and compliance of their applications (and of all TI products used in or for Designers' applications) with all applicable regulations, laws and other applicable requirements. Designer represents that, with respect to their applications, Designer has all the necessary expertise to create and implement safeguards that (1) anticipate dangerous consequences of failures, (2) monitor failures and their consequences, and (3) lessen the likelihood of failures that might cause harm and take appropriate actions. Designer agrees that prior to using or distributing any applications that include TI products, Designer will thoroughly test such applications and the functionality of such TI products as used in such applications.

TI's provision of technical, application or other design advice, quality characterization, reliability data or other services or information, including, but not limited to, reference designs and materials relating to evaluation modules, (collectively, "TI Resources") are intended to assist designers who are developing applications that incorporate TI products; by downloading, accessing or using TI Resources in any way, Designer (individually or, if Designer is acting on behalf of a company, Designer's company) agrees to use any particular TI Resource solely for this purpose and subject to the terms of this Notice.

TI's provision of TI Resources does not expand or otherwise alter TI's applicable published warranties or warranty disclaimers for TI products, and no additional obligations or liabilities arise from TI providing such TI Resources. TI reserves the right to make corrections, enhancements, improvements and other changes to its TI Resources. TI has not conducted any testing other than that specifically described in the published documentation for a particular TI Resource.

Designer is authorized to use, copy and modify any individual TI Resource only in connection with the development of applications that include the TI product(s) identified in such TI Resource. NO OTHER LICENSE, EXPRESS OR IMPLIED, BY ESTOPPEL OR OTHERWISE TO ANY OTHER TI INTELLECTUAL PROPERTY RIGHT, AND NO LICENSE TO ANY TECHNOLOGY OR INTELLECTUAL PROPERTY RIGHT OF TI OR ANY THIRD PARTY IS GRANTED HEREIN, including but not limited to any patent right, copyright, mask work right, or other intellectual property right relating to any combination, machine, or process in which TI products or services are used. Information regarding or referencing third-party products or services does not constitute a license to use such products or services, or a warranty or endorsement thereof. Use of TI Resources may require a license from a third party under the patents or other intellectual property of the third party, or a license from TI under the patents or other intellectual property of TI.

TI RESOURCES ARE PROVIDED "AS IS" AND WITH ALL FAULTS. TI DISCLAIMS ALL OTHER WARRANTIES OR REPRESENTATIONS, EXPRESS OR IMPLIED, REGARDING RESOURCES OR USE THEREOF, INCLUDING BUT NOT LIMITED TO ACCURACY OR COMPLETENESS, TITLE, ANY EPIDEMIC FAILURE WARRANTY AND ANY IMPLIED WARRANTIES OF MERCHANTABILITY, FITNESS FOR A PARTICULAR PURPOSE, AND NON-INFRINGEMENT OF ANY THIRD PARTY INTELLECTUAL PROPERTY RIGHTS. TI SHALL NOT BE LIABLE FOR AND SHALL NOT DEFEND OR INDEMNIFY DESIGNER AGAINST ANY CLAIM, INCLUDING BUT NOT LIMITED TO ANY INFRINGEMENT CLAIM THAT RELATES TO OR IS BASED ON ANY COMBINATION OF PRODUCTS EVEN IF DESCRIBED IN TI RESOURCES OR OTHERWISE. IN NO EVENT SHALL TI BE LIABLE FOR ANY ACTUAL, DIRECT, SPECIAL, COLLATERAL, INDIRECT, PUNITIVE, INCIDENTAL, CONSEQUENTIAL OR EXEMPLARY DAMAGES IN CONNECTION WITH OR ARISING OUT OF TI RESOURCES OR USE THEREOF, AND REGARDLESS OF WHETHER TI HAS BEEN ADVISED OF THE POSSIBILITY OF SUCH DAMAGES.

Unless TI has explicitly designated an individual product as meeting the requirements of a particular industry standard (e.g., ISO/TS 16949 and ISO 26262), TI is not responsible for any failure to meet such industry standard requirements.

Where TI specifically promotes products as facilitating functional safety or as compliant with industry functional safety standards, such products are intended to help enable customers to design and create their own applications that meet applicable functional safety standards and requirements. Using products in an application does not by itself establish any safety features in the application. Designers must ensure compliance with safety-related requirements and standards applicable to their applications. Designer may not use any TI products in life-critical medical equipment unless authorized officers of the parties have executed a special contract specifically governing such use. Life-critical medical equipment is medical equipment where failure of such equipment would cause serious bodily injury or death (e.g., life support, pacemakers, defibrillators, heart pumps, neurostimulators, and implantables). Such equipment includes, without limitation, all medical devices identified by the U.S. Food and Drug Administration as Class III devices and equivalent classifications outside the U.S.

TI may expressly designate certain products as completing a particular qualification (e.g., Q100, Military Grade, or Enhanced Product). Designers agree that it has the necessary expertise to select the product with the appropriate qualification designation for their applications and that proper product selection is at Designers' own risk. Designers are solely responsible for compliance with all legal and regulatory requirements in connection with such selection.

Designer will fully indemnify TI and its representatives against any damages, costs, losses, and/or liabilities arising out of Designer's non-compliance with the terms and provisions of this Notice.

Looking for pricing, stock, or lifecycle information?

Click below to explore more details on WIN SOURCE:

 [View CDCVF111FNR](#) on WIN SOURCE

 [Texas Instruments](#) Information

Optimize Your Supply Chain with WIN SOURCE Solutions

-  Global Sourcing Solution
-  Obsolete Management
-  Cost Control Management
-  Shortage Management
-  Alternative Solution
-  Excess Inventory Management