



**THE DATASHEET OF  
PD67124S**





DESCRIPTION

KEY FEATURES

Microsemi's™ new and unique family of Power over Ethernet (PoE) modules enable next-generation network devices to share data and power over the same cable. The PD671xxx PoE PSE modules are fit / form compatible with the standard plug-in memory modules used in personal computers (Dual Inline Memory Modules - DIMMs) (see Figure 1 and Figure 12). Thus, the use of these modules permit network devices to be designed for up to 96 ports, with fewer ports actually installed. Additional modules can be inserted in the field at any time.

The PD671xxx (8, 12 or 24 ports DIMM) includes a wide range of functions. Some of these modules include the PD69000 micro-controller unit (PoE controller) for Enhanced features and a flexible work environment in a DIMM master or DIMM slave configuration (refer to Ordering Information, page 2).

Microsemi's PoE PD671xxx DIMMs implement real time mechanisms including detection, classification, port real-time protection and system level functions (power management and MIB support).

Microsemi's PD69012 IC, 12-channel PoE Manager IC is at the heart of these modules. PD671xxx DIMMs enable the detection of IEEE802.3at-2009 Type 1 (low power) or Type 2 (high power) Powered Devices (PDs), ensuring safe power feeding and removal over Ethernet ports. The PD69012-based DIMMs detect and disable disconnected ports, using DC or AC disconnection methods. The DIMMs are embedded in multi-port and highly populated Ethernet switches, requiring a minimum of external components.

The PD671xxx DIMM is fully backwards compatible with the PD670xx DIMM and can be dropped into existing designs.



Figure 1: PoE PD67124 DIMM

- ◆ IEEE 802.3AT-2009 and IEEE802.3AF-2003 compliant
- ◆ Up to 30 W per port power PoE solution
- ◆ RoHS compliant
- ◆ Supports IETF PoE MIB (RFC 3621)
- ◆ Up to 24 power ports per single DIMM
- ◆ Up to 96 ports in a system, using master and slave configuration
- ◆ Thermal protection per port
- ◆ Thermal monitoring capabilities
- ◆ Pre-standard detection methods (Cisco Inline Power and Power over LAN Legacy)
- ◆ Non-standard terminals supported
- ◆ DC disconnect with DC modulation
- ◆ AC disconnect function utilizing external diodes
- ◆ PD 2-events classification function
- ◆ Operates using a single input (44 to 57 VDC)
- ◆ I<sup>2</sup>C or UART host interface
- ◆ Host communication is backward compatible with PD67024M communication, or Marvell® ISSR
- ◆ Programmable over current protection per port
- ◆ Built-in power management algorithm
- ◆ Internal power-on reset mechanism
- ◆ Fast port shutdown on power supply failure
- ◆ Supports Backplane Power Management
- ◆ Automatic on/off sequencer for 96 ports
- ◆ Disable/enable power per port
- ◆ Continuous port current monitoring
- ◆ Serial interface for LED indicator support
- ◆ Backwards compatible with PD670xx
- ◆ Fit/form compliant with 168-pin DIMM JEDEC MO-161F, 3.3 V
- ◆ Space efficient compact design
- ◆ Factory pre-tested, for plug-and-play integration
- ◆ Safety standard compliant: UL / cUL per UL60950-1 (mounted on Microsemi evaluation board)

IMPORTANT: For the most current data, consult Microsemi's website:  
<http://www.microsemi.com>



**PD671xxx - 8 / 12 / 24-Channel PoE AF and AT DIMM  
Data Sheet (Non-confidential)**

**Ordering Information**

| Part Number                    | Ports | Port Disconnect Method | DIMM Master/Slave    | Mode Enhanced/Auto <sup>[3]</sup> |
|--------------------------------|-------|------------------------|----------------------|-----------------------------------|
| PD67124MDC-gggg <sup>[1]</sup> | 24    | DC                     | Master               | Enhanced                          |
| PD67124S                       | 24    | AC/DC <sup>[4]</sup>   | Slave <sup>[2]</sup> | Enhanced                          |
| PD67112MDC-gggg                | 12    | DC                     | Master               | Enhanced                          |
| PD67108MDC-gggg                | 8     | DC                     | Master               | Enhanced                          |
| PD67124MAC-gggg                | 24    | AC                     | Master               | Enhanced                          |
| PD67112MAC-gggg                | 12    | AC                     | Master               | Enhanced                          |
| PD67108MAC-gggg                | 8     | AC                     | Master               | Enhanced                          |
| PD67124AM                      | 24    | AC/DC <sup>[5]</sup>   | Master               | Auto                              |
| PD67124AS                      | 24    | AC/DC <sup>[5]</sup>   | Slave <sup>[2]</sup> | Auto                              |
| PD67112AM                      | 12    | AC/DC <sup>[5]</sup>   | Master               | Auto                              |
| PD67108AM                      | 8     | AC/DC <sup>[5]</sup>   | Master               | Auto                              |

**Note:**

[1] – gggg: MCU software version.

[2] – DIMM Slave should be used in conjunction with DIMM Master (for systems require more than 24 ports).

[3] – Enhanced and Auto mode of operation stand for the PoE system features. The Enhanced mode system includes the PD69000 PoE controller.

[4] – DIMM Slave port disconnection method is determined by the DIMM Master which controllers it.

[5] – DIMM functioning at the Auto Mode Configuration can be configured to AC or DC port disconnection method by the system host. Further details can be found in the Auto Mode User Guide, Catalogue Number 06-1200-056.

**APPLICABLE DOCUMENTS**

- IEEE 802.3at-2009 standard, DTE Power via MDI
- PD69012 Data Sheet, Catalogue Number 06-0069-058
- PD69000 Data Sheet, Catalogue Number 06-0070-058
- Serial Communication Protocol User Guide 06-0032-056
- Auto Mode User Guide, Catalogue Number 06-1200-056
- Layout Design Guidelines for DIMM-based PoE Systems, AN-132 Catalogue Number 06-0010-080
- Designing a DIMM-based PoE System, AN-133 Catalogue Number 06-0011-080



**PD671xxx - 8 / 12 / 24-Channel PoE AF and AT DIMM  
Data Sheet (Non-confidential)**

**ABSOLUTE MAXIMUM RATINGS**

|  |                                |
|--|--------------------------------|
| Vmain  | -0.3 to 80 VDC <sup>(1)</sup>  |
| DGND, AGND, QGND                                       | -0.3 to 0.3 VDC <sup>(2)</sup> |
| VPORT_POSx, VPORT_NEGx                                 | -0.3 to 80 VDC <sup>(1)</sup>  |
| 3_3Vout  | 3.8 VDC                        |
| EXT_REG  | -0.3 to 6 VDC                  |
| I <sup>2</sup> C_Addr_M.                               | -0.3 to (3_3Vout + 0.3 VDC)    |
| MISO, MOSI, SCK, CS, SCL, SDA, SSn, Led_Cs, Asic_Reset | -0.3 to (3_3Vout + 0.3 VDC)    |
| ESD (Human Body Model)                                 | ± 2 kV <sup>(3)</sup>          |
| Storage temperature                                    | -40° to +125° C                |

**Notes:** "x" defines port numbers, 0 to 11, inclusive.

(1) 80 VDC is the transient voltage that can be applied for up to one minute.

(2) Maximum voltage value between grounds.

(3) ESD Human Body Model is: (CZap = 100 pF, RZap = 1500 Ω).

**Stresses beyond those listed above can cause permanent damage to the device. Exposure to absolute maximum rating conditions for extended periods could affect device reliability.**

**CALCULATED MTBF DATA <sup>[1]</sup>**

|                         | Operation mode    | Failures per 10 <sup>6</sup> Hours | MTBF(Hours) |
|-------------------------|-------------------|------------------------------------|-------------|
| PD67124M @ 25°C Ambient | IEEE 802.3AT-2009 | 0.5181                             | 1930000     |
| PD67124M @ 25°C Ambient | IEEE802.3AF-2003  | 0.5128                             | 1950000     |

**Notes:**

[1] – MTBF calculation made for the worst case PoE DIMM populated with 24 fully loaded ports



**PD671xxx - 8 / 12 / 24-Channel PoE AF and AT DIMM  
Data Sheet (Non-confidential)**

**OPERATING CONDITIONS**

| PARAMETER  | MIN.     | NOM.     | MAX.     | UNIT |
|--|----------|----------|----------|------|
| Operating ambient temperature                        | -10      |          | +70      | °C   |
| Operating voltage (see Figure 2)                     | 40 to 44 | 44 to 55 | 55 to 57 | VDC  |
| Operating humidity (non-condensing, Per IEC 68-2-56) |          |          | 95       | %    |

**Notes:**

- Operating functions depend on the input voltage.
- Operating voltage range for IEEE802.3af is 44 to 57 VDC
- Operating voltage range for IEEE802.3AT (High Power) is 50 to 57 VDC

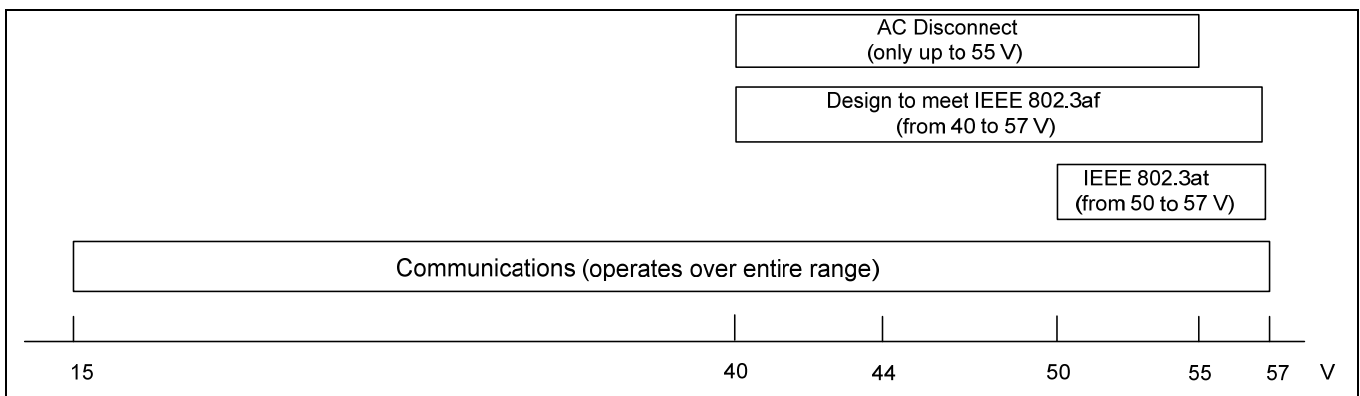

**Figure 2: Operational voltage Ranges**

**Airflow**

To prevent overheating, the application designer should supply a minimal airflow to the PD671xxx DIMMs. Figure 3 shows the power handling capability versus air velocities in meter/second, as measured at all points of the DIMM envelope, prior to insertion into the connector(s). As shown in Figure 12, the connectors are spaced by 35 mm; 1 m/s = 197 LFM (linear feet per minute). Maximum allowed temperature is +85° C for the MCU (PD69000) and +125° C for the PD69012.

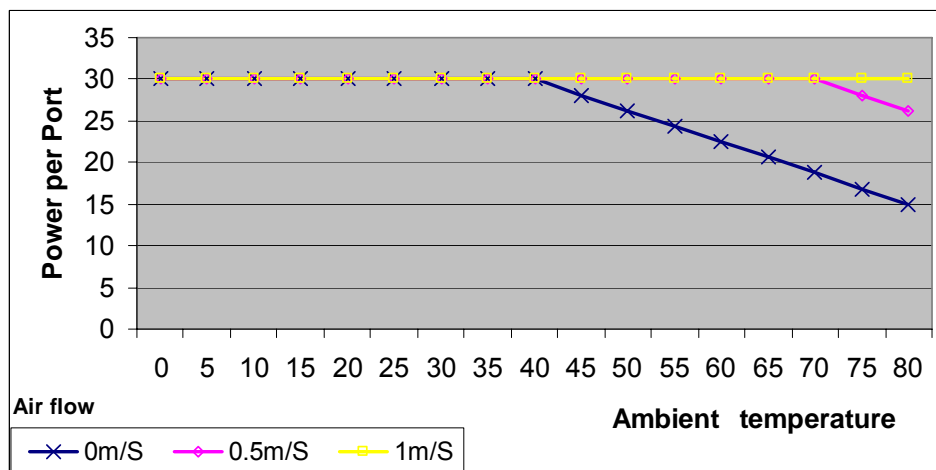

**Figure 3: Power per Port for two DIMMs (48 ports)**



## Electrical Characteristics

The following sections detail the DC and analog characteristics.

### DC Characteristics for Digital Inputs and Outputs

| PARAMETER                       | SYMBOL   | MIN.            | MAX. | UNIT    | REMARKS                 |
|---------------------------------|--|-----------------|------|---------|-------------------------|
| <b>Pin Name</b>                 | <b>SCL, xDisable_Ports, Rx (without internal pull-up/pull-down resistor)</b> |                 |      |         |                         |
| <b>Type</b>                     | <b>Schmitt Trigger CMOS input, TTL level</b>                                 |                 |      |         |                         |
| High level input voltage        | $V_{IH}$   | 2.0             |      | V       |                         |
| Low level input voltage         | $V_{IL}$   |                 | 0.8  | V       |                         |
| Input voltage hysteresis        |  | 0.3             |      | V       |                         |
| Input high current              | $I_{IH}$   | -1              | +1   | $\mu A$ |                         |
| Input low current               | $I_{IL}$   | -1              | +1   | $\mu A$ |                         |
| <b>Pin Name</b>                 | <b>MOSI, MISO, CS, Tx (without internal pull-up/down resistor)</b>           |                 |      |         |                         |
| <b>Type</b>                     | <b>SCK (with internal resistor)</b>  |                 |      |         |                         |
| <b>Type</b>                     | CMOS I/O, TTL level  |                 |      |         |                         |
| <b>High level input voltage</b> | $V_{IH}$   | 2.0             |      | V       |                         |
| Low level input voltage         | $V_{IL}$   |                 | 0.8  | V       |                         |
| Input voltage hysteresis        |  | 0.3             |      | V       |                         |
| Input high current              | $I_{IH}$   | -1              | +1   | $\mu A$ |                         |
| Input low current               | $I_{IL}$   | -1              | +1   | $\mu A$ |                         |
| High level output voltage       |  | $V_{PERI}-0.4V$ |      | V       | $I_{out} = 3\text{ mA}$ |
| Low level output voltage        |  |                 | 0.4  | V       | $I_{out} = 3\text{ mA}$ |
| Tri state output current        |  | -1              | +1   | $\mu A$ |                         |
| <b>Pin Name</b>                 | <b>xAsic_Reset (with internal resistor)</b>                                  |                 |      |         |                         |
| <b>Type</b>                     | <b>SDA (without internal resistor)</b>                                       |                 |      |         |                         |
| <b>Type</b>                     | CMOS open drain output with Schmitt Trigger input, TTL level                 |                 |      |         |                         |
| High level input voltage        | $V_{IH}$   | 2.0             |      | V       |                         |
| Low level output voltage        | $V_{OH}$   |                 | 0.4  | V       | $I_{out} = 3\text{ mA}$ |
| Low level input voltage         | $V_{IL}$   |                 | 0.8  | V       |                         |
| Input voltage hysteresis        |  | 0.3             |      | V       |                         |
| OFF state output current        |  | -1              | +1   | $\mu A$ |                         |

### Electrical Characteristics for Analog I/O Pads

| PARAMETER                      | MIN               | MAX   | UNIT    | REMARKS   |
|--------------------------------|-------------------|-------|---------|---|
| <b>Pin Name</b>                | <b>VPORT_POSx</b> |       |         |   |
| Operating voltage              | 44                | 62    | V       |   |
| Pin current consumption        | -5                | +10   | $\mu A$ | Port driver, Vport measurement and AC generator are off     |
| <b>Pin Name</b>                | <b>VPORT_NEGx</b> |       |         |   |
| Operating voltage              | 0                 | Vmain | V       | Port driver, Vport measurement and AC generator are off     |
| Pin current consumption        | -5                | +10   | $\mu A$ |   |
| <b>Pin Name</b>                | <b>Vmain</b>      |       |         |   |
| Operating voltage – AF mode    | 40                | 57    | V       | Recommended Range 48v to 55v                                |
| Operating voltage – AT mode    | 50                | 57    | V       | Recommended Range 51v to 55v                                |
| $V_{main}$ current consumption |                   | 40    | mA      | Total on $V_{main}$   |
| <b>Pin Name</b>                | <b>3_3Vout</b>    |       |         |   |
| Voltage                        | 3.13              | 3.46  | V       |   |
| Output current                 |                   | 6     | mA      | Without external NPN (see Q1 in Figure 8)                   |
|                                |                   | 30    | mA      | When using external NPN for $V_{PERI}$ (see Q1 in Figure 8) |



### Dynamic Characteristics

The PD671xxx DIMMs utilize three programmable current level thresholds ( $I_{min}$ ,  $I_{cut}$ ,  $I_{lim}$ ) and two timers ( $T_{min}$ ,  $T_{cut}$ ), to operate as shown in Figure 4. Loads that consume more than  $I_{cut}$  for longer than  $T_{cut}$  (OVL\_S to OVL) are categorized as 'overloads' and are automatically shutdown. Automatic recovery from overload and no-load conditions is attempted every  $T_{OVLREC}$  and  $T_{UDLREC}$  periods (typically 5 and 1 seconds, respectively). Output current is limited to  $I_{lim}$ , which is the maximum peak current allowed at each port.

### DC Disconnect

Output current consumption below  $I_{min}$  for more than  $T_{PMDO}$  (UDL\_S to UDL) is categorized as 'no-load' and is shutdown.

### AC Disconnect

A port maintains power if  $Z_{ac} < 27 K\Omega$

A port shutdowns power if  $Z_{ac} > 1980 K\Omega$  for a time period greater than  $T_{PMDO}$ .

| PARAMETER                               | CONDITIONS  | MIN. | TYP. | MAX. | UNIT      |
|---|---|------|------|------|-----------|
| Automatic recovery from                 | $T_{OVLREC}$ value, measured from port shutdown (can be modified via control port)              |      | 5    |      | s         |
| Automatic recovery from no-             | $T_{UDLREC}$ value, measured from port shutdown point (can be modified via control port)        |      | 1    |      | s         |
| Inrush current                          | $I_{Inrsh}$ For $t = 50$ ms, $C_{load} = 180$ uF max.   |      |      | 750  | mA        |
| Output current operating range          | $I_{port}$ Continuous operation after startup period  | 10   |      | 700  | mA        |
| Output power available, operating range | $P_{port}$ Continuous operation after startup period, at port output (@ $V_{port} = 57$ VDC)    | 0.57 |      | 30   | W         |
| DC disconnect OFF mode                  | $I_{min1}$ Must disconnect for $t$ greater than $T_{UVL}$                                       | 0    |      | 5    | mA        |
|   | $I_{min2}$ May or may not disconnect for $t$ greater than $T_{UVL}$                             | 5    | 7.5  | 10   | mA        |
| AC Disconnect OFF mode                  | $Z_{ac1}$ Does not remove power   |      |      | 27   | $K\Omega$ |
|   | $Z_{ac2}$ Remove power  | 1980 |      |      | $K\Omega$ |
| PD power maintenance                    | $T_{PMD}$ Buffer period to handle transitions   | 300  |      | 400  | ms        |
| Over load current detection range       | $I_{cut}$ Time limited to $T_{OVL}$   | 660  | 680  | 700  | mA        |
| Over load time limit                    | $T_{OVL}$ Typical timer accuracy is 2 ms  | 50   |      | 75   | ms        |
| Turn on rise time                       | $T_{rise}$ From 10% to 90% of $V_{port}$ (specified for PD load consisting of 100 uF capacitor) | 15   |      |      | us        |
| Port turn off time                      | $T_{off}$ From $V_{port}$ to 5 Vdc  |      |      | 500  | ms        |

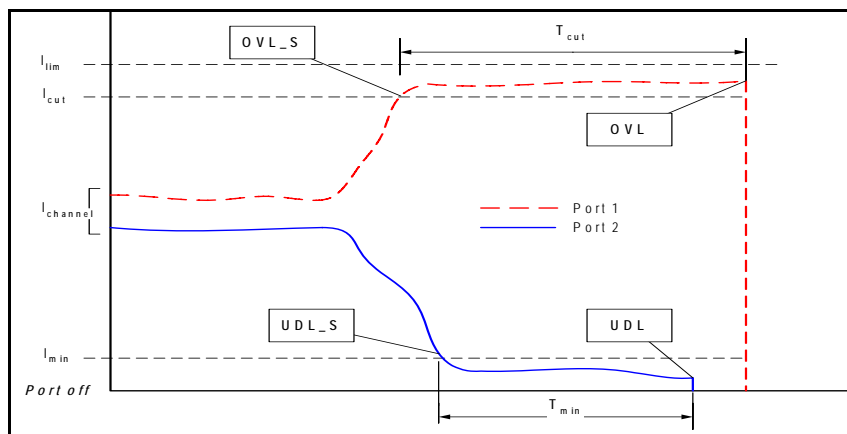

**Figure 4: Power Limits**



## Pin Designations

The PD671xxx DIMMs have a fit/form based on a JEDEC MO-161f outline.

Conventions used in the design are as follows:

- Power and ground connections are reproduced a number of times to carry heavy currents.
- Signals are categorized as analog (input or output) or digital (input, output and I/O).
- All lines which are identified with an "x" prefix are active when logical is low.

Refer to Figure 5.

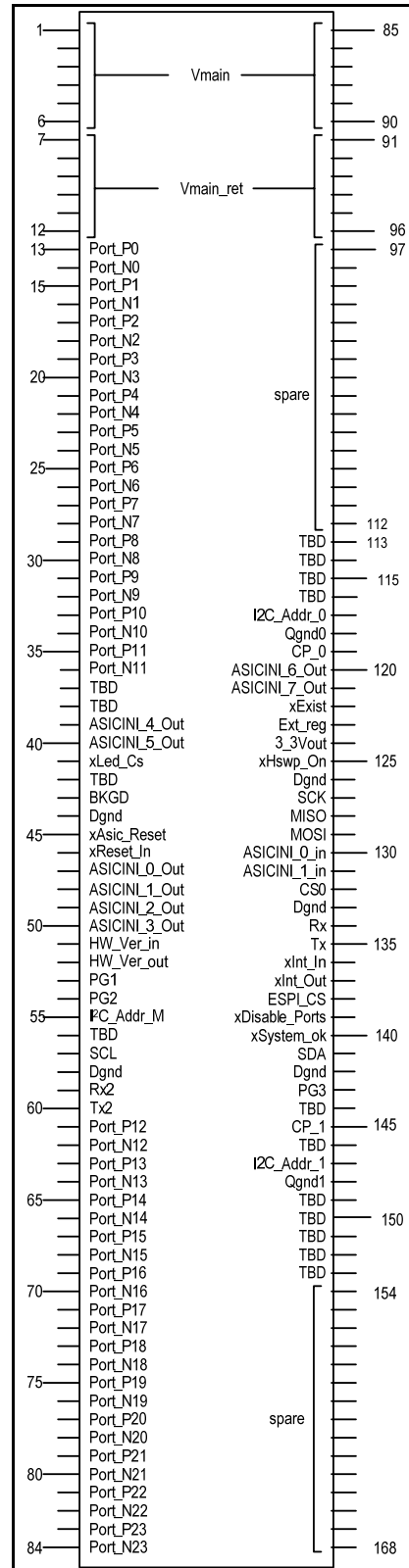

Figure 5: Pinout



**PD671xxx - 8 / 12 / 24-Channel PoE AF and AT DIMM  
Data Sheet (Non-confidential)**

**Pin Description**

Signals are categorized as 'analog' (input or output) or 'digital' (input, output and I/O).

| Pin | Pin Name      | Pin Type                   | Pin Description                                   | Pin           | Pin Name       | Pin Type                               | Pin Description                                      |
|-----|---------------|----------------------------|---|---------------|----------------|--|--|
| 1   | Vmain         | Power input                | Main V+ input                                     | 85            | Vmain          | Power input                            | Main V+ input  |
| 2   |               |                            |   | 86            |                |  |  |
| 3   |               |                            |   | 87            |                |  |  |
| 4   |               |                            |   | 88            |                |  |  |
| 5   |               |                            |   | 89            |                |  |  |
| 6   |               |                            |   | 90            |                |  |  |
| 7   | Vmain_ret     |                            | Main V return                                     | 91            | Vmain_ret      |  | Main V return  |
| 8   |               |                            |   | 92            |                |  |  |
| 9   |               |                            |   | 93            |                |  |  |
| 10  |               |                            |   | 94            |                |  |  |
| 11  |               |                            |   | 95            |                |  |  |
| 12  |               |                            |   | 96            |                |  |  |
| 13  | Port_P0       | Analog output              | Channel 1 positive output                         | 97            | Spare          |  |  |
| 14  | Port_N0       |                            | Channel 1 negative output                         | 98            |                |  |  |
| 15  | Port_P1       |                            | Channel 2 positive output                         | 99            |                |  |  |
| 16  | Port_N1       |                            | Channel 2 negative output                         | 100           |                |  |  |
| 17  | Port_P2       |                            | Channel 3 positive output                         | 101           |                |  |  |
| 18  | Port_N2       |                            | Channel 3 negative output                         | 102           |                |  |  |
| 19  | Port_P3       |                            | Channel 4 positive output                         | 103           |                |  |  |
| 20  | Port_N3       |                            | Channel 4 negative output                         | 104           |                |  |  |
| 21  | Port_P4       |                            | Channel 5 positive output                         | 105           |                |  |  |
| 22  | Port_N4       |                            | Channel 5 negative output                         | 106           |                |  |  |
| 23  | Port_P5       |                            | Channel 6 positive output                         | 107           |                |  |  |
| 24  | Port_N5       |                            | Channel 6 negative output                         | 108           |                |  |  |
| 25  | Port_P6       | Channel 7 positive output  | 109   |               |                |  |  |
| 26  | Port_N6       | Channel 7 negative output  | 100   |               |                |  |  |
| 27  | Port_P7       | Channel 8 positive output  | 111   |               |                |  |  |
| 28  | Port_N7       | Channel 8 negative output  | 112   |               |                |  |  |
| 29  | Port_P8       | Channel 9 positive output  | 113   | TBD           |                | TBD                                    |  |
| 30  | Port_N8       | Channel 9 negative output  | 114   | TBD           |                | TBD                                    |  |
| 31  | Port_P9       | Channel 10 positive output | 115   | TBD           |                | TBD                                    |  |
| 32  | Port_N9       | Channel 10 negative output | 116   | TBD           |                | TBD                                    |  |
| 33  | Port_P10      | Channel 11 positive output | 117   | I2C_Addr_0    | Digital input  | Auto mode; sets I2C address            |  |
| 34  | Port_N10      | Channel 11 negative output | 118   | Qgnd0         | Ground         | Quiet ground                           |  |
| 35  | Port_P11      | Channel 12 positive output | 119   | CP_0          | Analog output  | NC (not in use)                        |  |
| 36  | Port_N11      | Channel 12 negative output | 120   | ASICINI_6_Out | Analog output  | Determine DIMM 4 managers ESPI address |  |
| 37  | TBD           | TBD                        | 121   | ASICINI_7_Out |                |  |  |
| 38  | TBD           | TBD                        | 122   | xExist        | Digital output | Grounded internally- DIMM is present   |  |
| 39  | ASICINI_4_Out | Analog output              | Determine DIMM 3 managers ESPI address            | 123           | Ext_reg        | Analog output                          | External regulation for 3.3 V                        |
| 40  | ASICINI_5_Out |                            |   | 124           | 3_3Vout        | Analog output                          | 3.3 V output to support opto couplers (5 V tolerant) |
| 41  | xLed_Cs       | Digital output             | CS for LED support                                | 125           | XHswp_On       | Digital output                         | Connect to MCU                                       |
| 42  | TBD           | TBD                        | TBD   | 126           | DGND           | Ground                                 | Digital ground                                       |
| 43  | BKGD          | Digital input              | Factory use only                                  | 127           | SCK            | Digital I/O                            | SPI clock – PD69012 internal comm                    |
| 44  | DGND          | Ground                     | Digital ground                                    | 128           | MISO           | Digital I/O                            | SPI I/O – PD69012 internal comm                      |
| 45  | xAsic_Reset   | Digital I/O                | Internal reset to PD69012                         | 129           | MOSI           | Digital I/O                            | SPI I/O – PD69012 internal comm                      |
| 46  | xReset_In     | Digital input              | A reset signal driven by the Host CPU to PoE DIMM | 130           | ASICINI_0_In   | Analog input                           | Determine DIMM managers ESPI address                 |
| 47  | ASICINI_0_Out | Analog output              | Determine DIMM 1 manager ESPI address             | 131           | ASICINI_1_In   | Analog input                           | Determine DIMM managers ESPI address                 |
| 48  | ASICINI_1_Out | Analog output              | Determine DIMM 1 managers ESPI address            | 132           | CS0            | Digital I/O                            | CS for ESPI  |
| 49  | ASICINI_2_Out | Analog output              | Determine DIMM 2 managers ESPI address            | 133           | DGND           | Ground                                 | Digital ground                                       |



**PD671xxx - 8 / 12 / 24-Channel PoE AF and AT DIMM  
Data Sheet (Non-confidential)**

| Pin | Pin Name      | Pin Type       | Pin Description                      | Pin | Pin Name       | Pin Type       | Pin Description  |
|-----|---------------|----------------|--------------------------------------|-----|----------------|----------------|--|
| 50  | ASICINI_3_Out |                |                                      | 134 | Rx             | Digital input  | UART input   |
| 51  | HW_Ver_in     | Analog input   | Receives the hardware version        | 135 | Tx             | Digital output | UART output  |
| 52  | HW_Ver_out    | Analog output  | Reports on the hardware version      | 136 | xInt_In        | Digital input  | NC (not in use)  |
| 53  | PG1           | Digital input  | Indicates PS 1 is good; low= PS bad. | 137 | xInt_Out       | Digital output | Interrupt out signal   |
| 54  | PG2           | Digital input  | Indicates PS 2 is good; low= PS bad. | 138 | ESPI_CS        | Digital I/O    | CS for ESPI between DIMMs                                    |
| 55  | I2C_Addr_M    | Analog input   | Enhanced mode – sets I2C address     | 139 | xDisable_Ports | Digital input  | Low=disable from host  |
| 56  | TBD           |                | TBD                                  | 140 | xSystem_ok     | Digital output | Main DC input status indicator; low = Vmain is out of range. |
| 57  | SCL           | Digital I/O    | I2C clock                            | 141 | SDA            | Digital I/O    | I2C data   |
| 58  | DGND          | Ground         | Digital ground                       | 142 | DGND           | Ground         | Digital ground   |
| 59  | Rx2           | Digital input  | NC (not in use)                      | 143 | PG3            | Digital input  | Indicates PS 3 is good, low= PS bad                          |
| 60  | Tx2           | Digital output | NC (not in use)                      | 144 | TBD            |                | TBD  |
| 61  | Port_P12      | Analog output  | Channel 13 positive output           | 145 | CP_1           | Analog output  | NC (not in use)  |
| 62  | Port_N12      | Analog output  | Channel 13 negative output           | 146 | TBD            |                | TBD  |
| 63  | Port_P13      |                | Channel 14 positive output           | 147 | I2C_Addr_1     | Digital input  | Auto mode; sets I2C address                                  |
| 64  | Port_N13      |                | Channel 14 negative output           | 148 | Qgnd1          | Ground         | Quiet ground   |
| 65  | Port_P14      |                | Channel 15 positive output           | 149 | TBD            |                | TBD  |
| 66  | Port_N14      |                | Channel 15 negative output           | 150 | TBD            |                | TBD  |
| 67  | Port_P15      |                | Channel 16 positive output           | 151 | TBD            |                | TBD  |
| 68  | Port_N15      |                | Channel 16 negative output           | 152 | TBD            |                | TBD  |
| 69  | Port_P16      |                | Channel 17 positive output           | 153 | TBD            |                | TBD  |
| 70  | Port_N16      |                | Channel 17 negative output           | 154 | Spare          |                |  |
| 71  | Port_P17      |                | Channel 18 positive output           | 155 |                |                |  |
| 72  | Port_N17      |                | Channel 18 negative output           | 156 |                |                |  |
| 73  | Port_P18      |                | Channel 19 positive output           | 157 |                |                |  |
| 74  | Port_N18      |                | Channel 19 negative output           | 158 |                |                |  |
| 75  | Port_P19      |                | Channel 20 positive output           | 159 |                |                |  |
| 76  | Port_N19      |                | Channel 20 negative output           | 160 |                |                |  |
| 77  | Port_P20      |                | Channel 21 positive output           | 161 |                |                |  |
| 78  | Port_N20      |                | Channel 21 negative output           | 162 |                |                |  |
| 79  | Port_P21      |                | Channel 22 positive output           | 163 |                |                |  |
| 80  | Port_N21      |                | Channel 22 negative output           | 164 |                |                |  |
| 81  | Port_P22      |                | Channel 23 positive output           | 165 |                |                |  |
| 82  | Port_N22      |                | Channel 23 negative output           | 166 |                |                |  |
| 83  | Port_P23      |                | Channel 24 positive output           | 167 |                |                |  |
| 84  | Port_N23      |                | Channel 24 negative output           | 168 |                |                |  |



## Functional Description

The following sections detail the PD671xxx DIMM Master functions.

### System Level

Figure 6 illustrates a 24-port Enhanced mode system based on the PD671xxx DIMM Master.

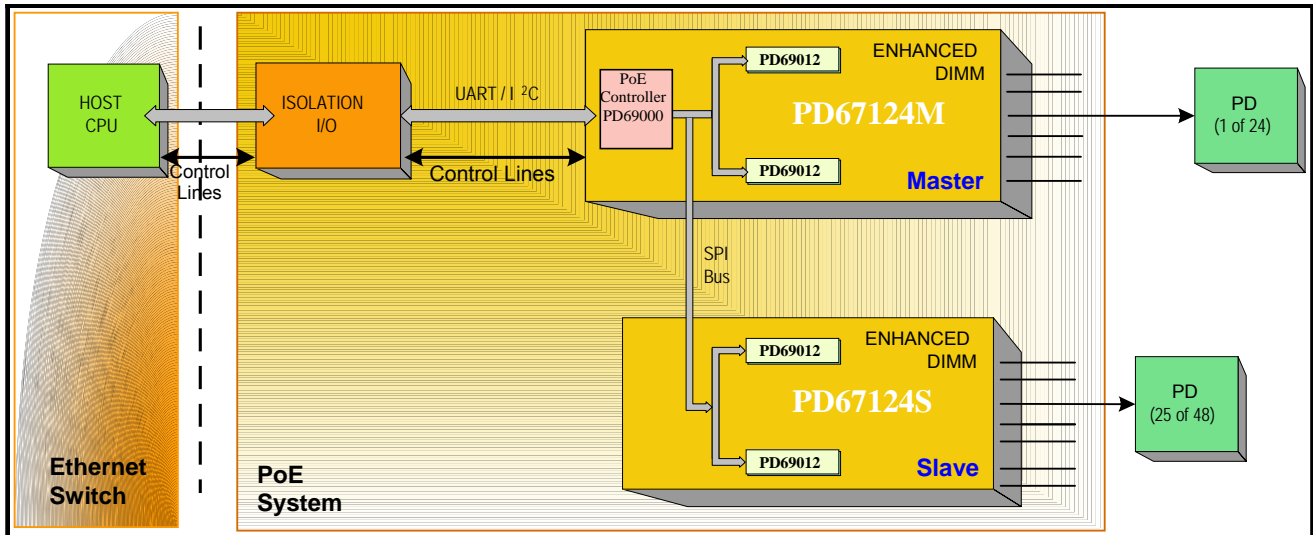

Figure 6: PD67124M/S DIMM Configuration

Figure 7 illustrates a 24-port Auto mode system based on the PD671xxx DIMM Master.

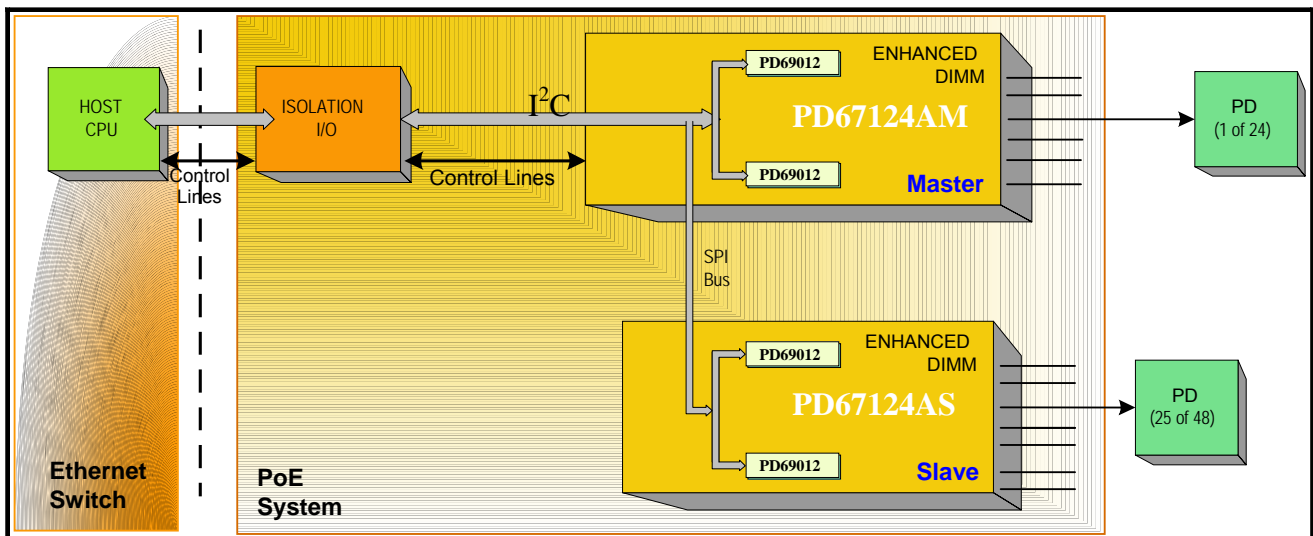

Figure 7: PD67124AM/AS DIMM Configuration



## Enhanced Mode PD671xxx DIMM Block Diagram

Figure 8 illustrates the internal circuitry of the Enhanced Mode DIMM Master. PD69012 appears only in one of the 12 port circuits.

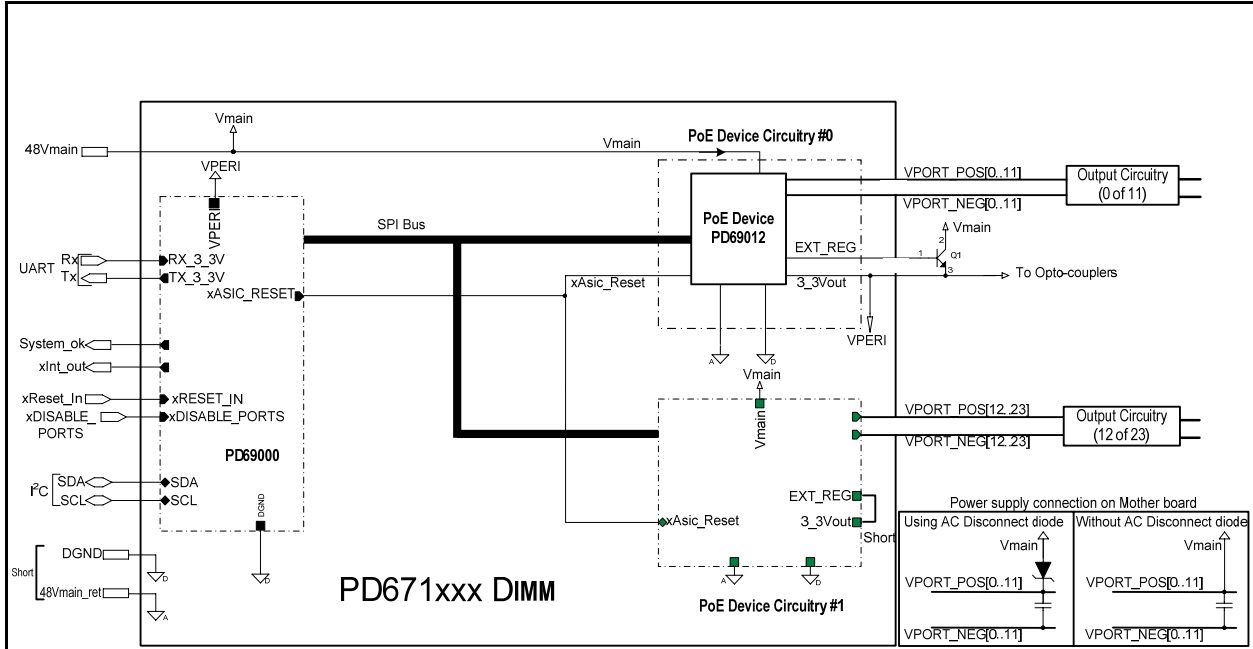

Figure 8: PD67124M DIMM, Internal Block Diagram

### Top Assembly Description

The following sections detail the top assembly components.

#### Power Supply

The entire circuit is powered by a nominal 48 VDC potential (Vmain can range from 44 to 57 VDC for AF mode and 50 to 57 VDC for AT high power mode).

#### 3.3 VDC Regulator

Each of the PD69012 includes a 3.3 VDC regulator (EXT\_REG and 3\_3Vout) for up to 6 mA. This current is utilized for powering external components in the PoE domain. There is an option of adding a driver to this output to drive higher loads. Q1 provides up to 30 mA to the PoE controller and to the opto-couplers in the interface circuit. The total capacitance on the 3.3 VDC should be less than 4.7 uF (with and without an external driver).

#### Grounds

The overall circuit includes two physical ground planes, analog and digital, which are electrically connected at a single point on the motherboard (see Figure 9 and Figure 10). This method, used throughout the design, improves noise immunity and coupling. Application note AN-132, Catalogue

Number 06-0010-080 provides further details about this design technique.

#### Control Signals

Several control signals are utilized between the switch and the PoE circuitry:

- **xReset\_In:** Driven by the switch circuitry to reset the PoE circuit.
- **xDISABLE\_PORTS:** Driven by the switch, to disable all PoE ports immediately.

#### Indication Signals

- **Int\_out:** Enables the Host CPU to reduce the communication volume whenever a PoE event masked by the Host CPU occurs. The PoE Controller sends an interrupt for indication.
- **System\_ok: (Enhanced mode only)** An optional hardware single line, driven by the Master DIMM to the Host CPU; this signal provides the Host CPU with a warning that a major failure such as Vmain out of range has occurred.



### PD69012 Circuitry

All PD69012s work in slave mode, under control of the PD69000G. The PoE Managers, each controlling 12 output ports, are further detailed in Figure 8. The ports can be disabled by the Ethernet switch via the **xDisable\_Ports** signal or by the PoE controller, as required during operation. For further details on the PoE manager, refer to the PoE manager PD69012 Data Sheet, Catalogue Number 06-0072-058.

### AC Disconnect Diodes

When deploying an application that utilizes the AC disconnect method, carefully select the diode type and diode location on the mother board. The diode should be located away from the DIMM to prevent mutual heating and the ventilation should be doubled to deal with higher power dissipation. The AC disconnect diode should be connected as shown in Figure 9.

### DC Disconnect

Using the DC disconnect method, the mother board should contain a short circuit between Vmain coming from the power supply and Port\_P[0-23] as illustrated in Figure 10.

## PD671xxx DIMM Evaluation Board

The performance features of Microsemi's PoE DIMMs can be fully appreciated using the PD671xxx - DIMM Evaluation Board.

The Evaluation Board allows the designer to evaluate all of the DIMMs accessible functions. Enhanced mode configuration for up to 48 ports is supported.

## Applications

The DIMMs can be integrated into a number of applications, ranging from daughter boards to full integration into Ethernet switches.

Examples of such applications are as follows:

- **Integrated directly into a switch:** Facilitates the entire PoE concept by including the DIMMs on the main switch PCB.
- **Daughter board add-on:** DIMMs are integrated into a small PCB for PoE, mounted on top of the switch's main PCB.
- **Midspan units:** Stand-alone devices, installed between the Ethernet switch and powered devices (telephone, camera, wireless LAN, etc.). These Midspan units include the DIMMs as a PoE control element, injecting power over the communication lines.

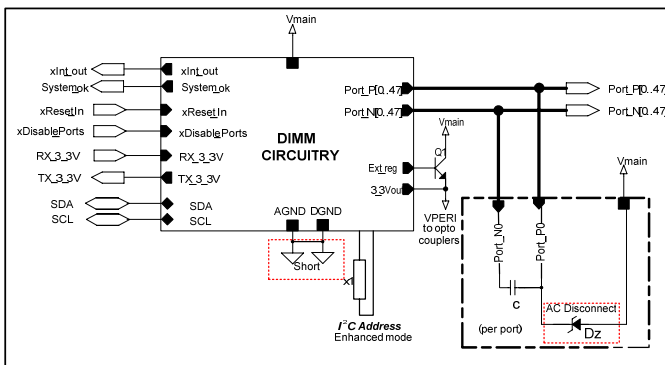

Figure 9: Overall PD671xxx DIMM at AC Disconnect Wiring Diagram

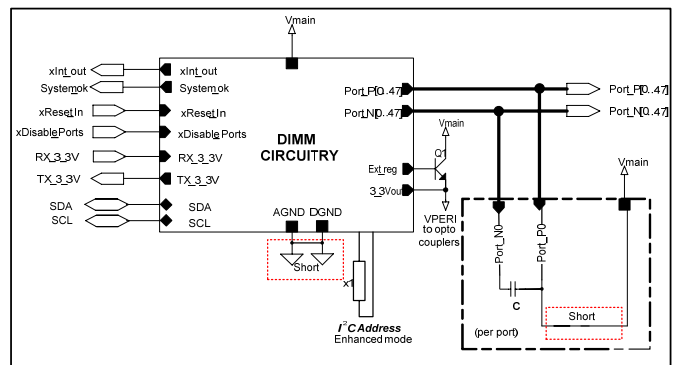

Figure 10: Overall PD671xxx DIMM at DC Disconnect Wiring Diagram



**PD671xxx - 8 / 12 / 24-Channel PoE AF and AT DIMM  
Data Sheet (Non-confidential)**

## Power Dissipation

The PD671xxx power dissipation is concentrated within a few components distributed along the board as follows. These power dissipation calculations are based on a 24 port DIMM supplied by a 48 VDC power supply and located at ambient temperature of 70° C.

| COMPONENT    | DESCRIPTION          | UNITS | POWER DISSIPATION [W]     |                          |                           |
|--------------|----------------------|-------|---------------------------|--------------------------|---------------------------|
|              |                      |       | IEEE802.3AF<br>0.35A/PORT | IEEE802.3AT<br>0.6A/PORT | IEEE802.3AT<br>0.65A/PORT |
| Rs           | Senses resistor      | 24    | 1.43                      | 4.21                     | 4.94                      |
| Mosfet       | PoE switching Mosfet | 24    | 0.56                      | 1.64                     | 1.93                      |
| PD69012      | PoE manager          | 2     | 1.15                      | 1.15                     | 1.15                      |
| PD69000      | PoE controller       | 1 *   | 0.02                      | 0.02                     | 0.02                      |
| <b>Total</b> |                      |       | <b>3.16</b>               | <b>7.02</b>              | <b>8.04</b>               |

\* Enhanced mode Master board only

**Important:** When deploying an application utilizing the AC disconnect method, carefully select the diode type and diode location on the mother board. The diode should be located away from the DIMM to prevent mutual heating and the ventilation should be doubled to deal with higher power dissipation.

AC disconnect diodes power dissipation is based on 1 VDC forward voltage.

| COMPONENT | DESCRIPTION         | UNITS | POWER DISSIPATION [W]     |                          |                           |
|-----------|---------------------|-------|---------------------------|--------------------------|---------------------------|
|           |                     |       | IEEE802.3AF<br>0.35A/PORT | IEEE802.3AT<br>0.6A/PORT | IEEE802.3AT<br>0.65A/PORT |
| Diode     | AC disconnect diode | 24    | 8.4                       | 14.4                     | 15.6                      |

## Physical Information

Figure 11 shows the PD671xxx DIMM mechanical outline, which can be used in printed circuit layout design. PD671xxx DIMMs are designed to be mounted onto a 168-contact DIMM connector, capable of accepting JEDEC MO-161 modules. All units are in millimeters.

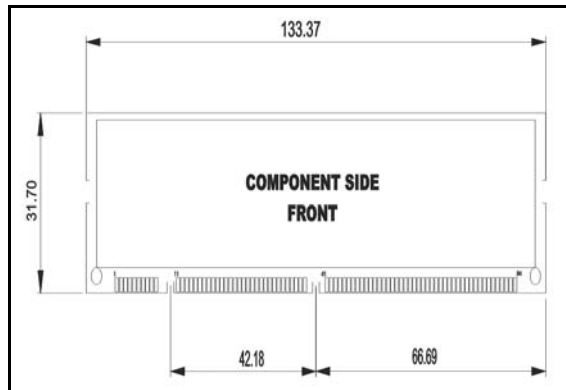

**Figure 11: DIMM Dimensions**

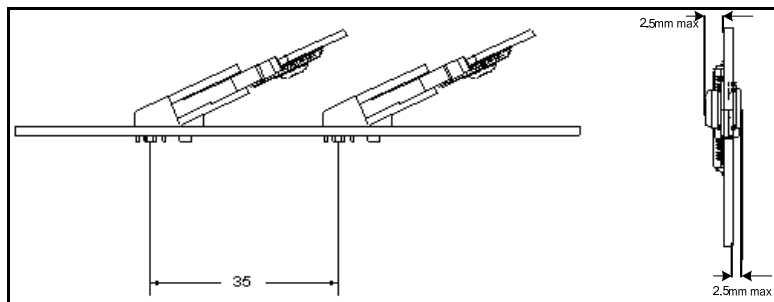

**Figure 12: Mechanical Outline of the PD671xxx DIMM**



**PD671xxx - 8 / 12 / 24-Channel PoE AF and AT DIMM  
Data Sheet (Non-confidential)**

Revision History

| Revision Level / Date | Para. Affected | Description     |
|-----------------------|----------------|-----------------|
| 0.1 / Oct. 1 , 2009   |                | Initial release |
| 0.2 / Oct. 29 , 2009  | Overall doc    |                 |
| 1.0 / 17-March-10     |                | Formal release  |

**© 2009 Microsemi Corp.  
All rights reserved.**



For support contact: sales\_AMSG@microsemi.com

Visit our web site at: www.microsemi.com

**Catalogue Number: 06-0021-058**

## Looking for pricing, stock, or lifecycle information?

Click below to explore more details on WIN SOURCE:

-  [View PD67124S on WIN SOURCE](#)
-  [Microsemi Corporation Information](#)

## Optimize Your Supply Chain with WIN SOURCE Solutions

-  Global Sourcing Solution
-  Obsolete Management
-  Cost Control Management
-  Shortage Management
-  Alternative Solution
-  Excess Inventory Management