



**THE DATASHEET OF  
CDCU877AGQLR**



# CDCU877/CDCU877A

## 1.8-V PHASE LOCK LOOP CLOCK DRIVER

SCAS688A – JUNE 2003 – REVISED JANUARY 2004

- 1.8-V Phase Lock Loop Clock Driver for Double Data Rate (DDR II) Applications
- Spread Spectrum Clock Compatible
- Operating Frequency: 10 MHz to 400 MHz
- Low Current Consumption: <135 mA
- Low Jitter (Cycle-Cycle):  $\pm 30$  ps
- Low Output Skew: 35 ps
- Low Period Jitter:  $\pm 20$  ps
- Low Dynamic Phase Offset:  $\pm 15$  ps
- Low Static Phase Offset:  $\pm 50$  ps
- Distributes One Differential Clock Input to Ten Differential Outputs
- 52-Ball  $\mu$ BGA (MicroStar Junior™ BGA, 0,65-mm pitch) and 40-Pin MLF
- External Feedback Pins (FBIN,  $\overline{\text{FBIN}}$ ) are Used to Synchronize the Outputs to the Input Clocks
- Single-Ended Input and Single-Ended Output Modes
- Meets or Exceeds JESD82-8 PLL Standard for PC2-3200/4300
- Fail-Safe Inputs

### description

The CDCU877 is a high-performance, low-jitter, low-skew, zero-delay buffer that distributes a differential clock input pair (CK,  $\overline{\text{CK}}$ ) to ten differential pairs of clock outputs (Yn,  $\overline{\text{Yn}}$ ) and to one differential pair of feedback clock outputs (FBOU,  $\overline{\text{FBOU}}$ ). The clock outputs are controlled by the input clocks (CK,  $\overline{\text{CK}}$ ), the feedback clocks (FBIN,  $\overline{\text{FBIN}}$ ), the LVCMOS control pins (OE, OS), and the analog power input ( $\text{AV}_{\text{DD}}$ ). When OE is low, the clock outputs, except FBOU/ $\overline{\text{FBOU}}$ , are disabled while the internal PLL continues to maintain its locked-in frequency. OS (output select) is a program pin that must be tied to GND or  $\text{V}_{\text{DD}}$ . When OS is high, OE functions as previously described. When OS and OE are both low, OE has no effect on Y7/ $\overline{\text{Y7}}$ , they are free running. When  $\text{AV}_{\text{DD}}$  is grounded, the PLL is turned off and bypassed for test purposes.

When both clock inputs (CK,  $\overline{\text{CK}}$ ) are logic low, the device enters in a low power mode. An input logic detection circuit on the differential inputs, independent from input buffers, detects the logic low level and performs in a low power state where all outputs, the feedback, and the PLL are off. When the clock inputs transition from being logic low to being differential signals, the PLL turns back on, the inputs and the outputs are enabled, and the PLL obtains phase lock between the feedback clock pair (FBIN,  $\overline{\text{FBIN}}$ ) and the clock input pair (CK,  $\overline{\text{CK}}$ ) within the specified stabilization time.

The CDCU877 is able to track spread spectrum clocking (SSC) for reduced EMI. This device operates from  $-40^{\circ}\text{C}$  to  $85^{\circ}\text{C}$ .

#### AVAILABLE OPTIONS

T <sub>A</sub>	52-Ball BGA	40-Pin MLF
$-40^{\circ}\text{C}$ to $85^{\circ}\text{C}$	CDCU877ZQL (Pb-Free)	CDCU877RTB
$-40^{\circ}\text{C}$ to $85^{\circ}\text{C}$	CDCU877AZQL (Pb-Free)	CDCU877ARTB
$-40^{\circ}\text{C}$ to $85^{\circ}\text{C}$	CDCU877GQL	
$-40^{\circ}\text{C}$ to $85^{\circ}\text{C}$	CDCU877AGQL	



Please be aware that an important notice concerning availability, standard warranty, and use in critical applications of Texas Instruments semiconductor products and disclaimers thereto appears at the end of this data sheet.

MicroStar Junior is a trademark of Texas Instruments.

PRODUCTION DATA information is current as of publication date. Products conform to specifications per the terms of Texas Instruments standard warranty. Production processing does not necessarily include testing of all parameters.



POST OFFICE BOX 655303 • DALLAS, TEXAS 75265

Copyright © 2004, Texas Instruments Incorporated

# CDCU877/CDCU877A

## 1.8-V PHASE LOCK LOOP CLOCK DRIVER

SCAS688A – JUNE 2003 – REVISED JANUARY 2004

MicroStar™ Junior (GQL) Package  
(TOP VIEW)

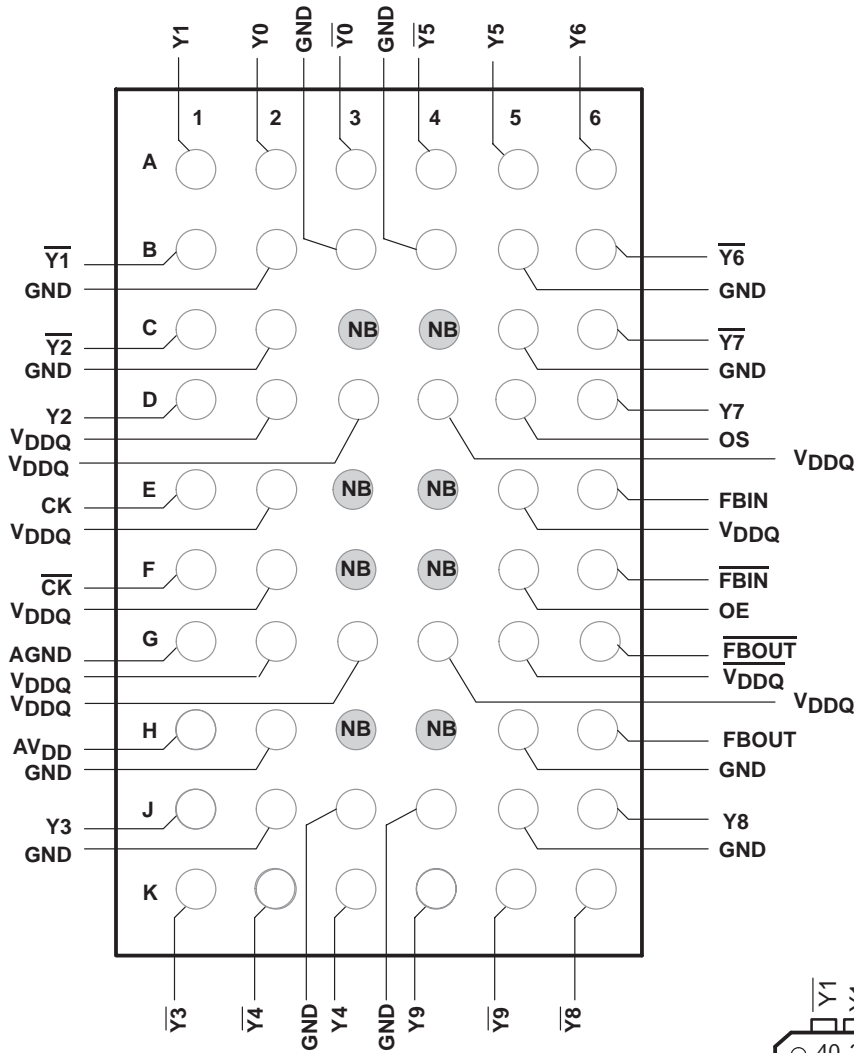

NC - No Connection  
NB - No Ball

RTB PACKAGE  
(TOP VIEW)

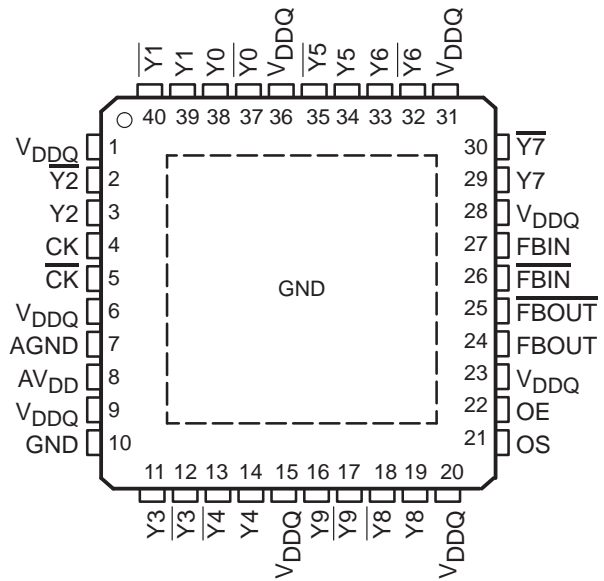

40-pin HP-VFQFP-N (6,0 x 6,0 mm Body Size,  
0,5 mm Pitch, M0#220, Variation VJJD-2,  
E2 = D2 = 2,9 mm ± 0,15 mm) Package Pinouts



POST OFFICE BOX 655303 • DALLAS, TEXAS 75265

**Table 1. Terminal Functions**

NAME	BGA	MLF	I/O	DESCRIPTION
AGND	G1	7		Analog ground
AV <sub>DD</sub>	H1	8		Analog power
CK	E1	4	I	Clock input with a (10 kΩ to 100 kΩ) pulldown resistor
$\overline{\text{CK}}$	F1	5	I	Complementary clock input with a (10 kΩ to 100 kΩ) pulldown resistor
FBIN	E6	27	I	Feedback clock input
$\overline{\text{FBIN}}$	F6	26	I	Complementary feedback clock input
FBOU <sub>T</sub>	H6	24	O	Feedback clock output
$\overline{\text{FBOU}}_{\text{T}}$	G6	25	O	Complementary feedback clock output
OE	F5	22	I	Output enable (asynchronous)
OS	D5	21	I	Output select (tied to GND or V <sub>DD</sub> )
GND	B2, B3, B4, B5, C2, C5, H2, H5, J2, J3, J4, J5	10		Ground
V <sub>DDQ</sub>	D2, D3, D4, E2, E5, F2, G2, G3, G4, G5	1, 6, 9, 15, 20, 23, 28, 31, 36		Logic and output power
Y[0:9]	A2, A1, D1, J1, K3, A5, A6, D6, J6, K4	38, 39, 3, 11, 14, 34, 33, 29, 19, 16	O	Clock outputs
$\overline{\text{Y}}[0:9]$	A3, B1, C1, K1, K2, A4, B6, C6, K6, K5	37, 40, 2, 12, 13, 35, 32, 30, 18, 17	O	Complementary clock outputs

**Table 2. Function Table**

INPUTS					OUTPUTS				PLL
AV <sub>DD</sub>	OE	OS	CK	$\overline{\text{CK}}$	Y	$\overline{\text{Y}}$	FBOU <sub>T</sub>	$\overline{\text{FBOU}}_{\text{T}}$	
GND	H	X	L	H	L	H	L	H	Bypassed/Off
GND	H	X	H	L	H	L	H	L	Bypassed/Off
GND	L	H	L	H	L <sub>Z</sub>	L <sub>Z</sub>	L	H	Bypassed/Off
GND	L	L	H	L	L <sub>Z</sub> Y7 Active	$\overline{\text{L}}_{\text{Z}}$ $\overline{\text{Y}}7$ Active	H	L	Bypassed/Off
1.8 V Nominal	L	H	L	H	L <sub>Z</sub>	L <sub>Z</sub>	L	H	On
1.8 V Nominal	L	L	H	L	L <sub>Z</sub> Y7 Active	$\overline{\text{L}}_{\text{Z}}$ $\overline{\text{Y}}7$ Active	H	L	On
1.8 V Nominal	H	X	L	H	L	H	L	H	On
1.8 V Nominal	H	X	H	L	H	L	H	L	On
1.8 V Nominal	X	X	L	L	L <sub>Z</sub>	L <sub>Z</sub>	L <sub>Z</sub>	L <sub>Z</sub>	Off
X	X	X	H	H	Reserved				

# CDCU877/CDCU877A

## 1.8-V PHASE LOCK LOOP CLOCK DRIVER

SCAS688A – JUNE 2003 – REVISED JANUARY 2004

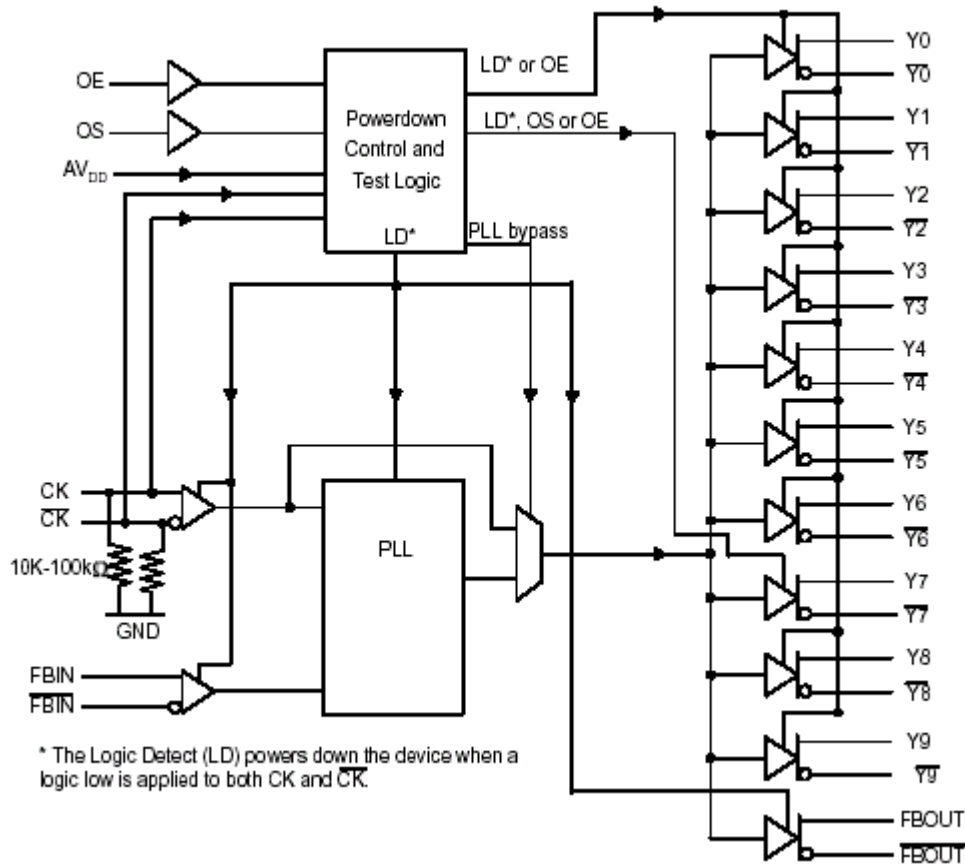

Figure 1. Logic Diagram (Positive Logic)

# CDCU877/CDCU877A

## 1.8-V PHASE LOCK LOOP CLOCK DRIVER

SCAS688A – JUNE 2003 – REVISED JANUARY 2004

### absolute maximum ratings over operating free-air temperature (unless otherwise noted)†

Supply voltage range, $V_{DDQ}$ or $AV_{DD}$	–0.5 V to 2.5 V
Input voltage range, $V_I$ (see Notes 1 and 2)	–0.5 V to $V_{DDQ} + 0.5$ V
Output voltage range, $V_O$ (see Notes 1 and 2)	–0.5 V to $V_{DDQ} + 0.5$ V
Input clamp current, $I_{IK}$ ( $V_I < 0$ or $V_I > V_{DDQ}$ )	±50 mA
Output clamp voltage, $I_{OK}$ ( $V_O < 0$ or $V_O > V_{DDQ}$ )	±50 mA
Continuous output current, $I_O$ ( $V_O = 0$ to $V_{DDQ}$ )	±50 mA
Continuous current through each $V_{DDQ}$ or GND	±100 mA
Storage temperature range, $T_{STG}$	–65°C to 150°C

† Stresses beyond those listed under “absolute maximum ratings” may cause permanent damage to the device. These are stress ratings only, and functional operation of the device at these or any other conditions beyond those indicated under “recommended operating conditions” is not implied. Exposure to absolute-maximum-rated conditions for extended periods may affect device reliability.

- NOTES: 1. The input and output voltage ratings may be exceeded if the input and output clamp-current ratings are observed  
 2. This value is limited to 2.5 V maximum.

### recommended operating conditions

			MIN	NOM	MAX	UNIT
$V_{DDQ}$	Output supply voltage		1.7	1.8	1.9	V
$AV_{DD}$	Supply voltage	See Note 1	$V_{DDQ}$			
$V_{IL}$	Low-level input voltage (see Note 2)	OE, OS	$0.35 \times V_{DDQ}$			V
$V_{IH}$	High-level input voltage (see Note 2)	CK, $\overline{CK}$	$0.65 \times V_{DDQ}$			V
$I_{OH}$	High-level output current (see Figure 2)		–9			mA
$I_{OL}$	Low-level output current (see Figure 2)		9			mA
$V_{IX}$	Input differential-pair cross voltage		$(V_{DDQ}/2) - 0.15$		$(V_{DDQ}/2) + 0.15$	V
$V_I$	Input voltage level		–0.3		$V_{DDQ} + 0.3$	V
$V_{ID}$	Input differential voltage (see Note 2 and Figure 9)	DC	0.3		$V_{DDQ} + 0.4$	V
		AC	0.6		$V_{DDQ} + 0.4$	V
$T_A$	Operating free-air temperature		–40		85	°C

- NOTES: 1. The PLL is turned off and bypassed for test purposes when  $AV_{DD}$  is grounded. During this test mode,  $V_{DDQ}$  remains within the recommended operating conditions and no timing parameters are ensured.  
 2.  $V_{ID}$  is the magnitude of the difference between the input level on CK and the input level on  $\overline{CK}$ , see Figure 9 for definition. The CK and  $\overline{CK}$   $V_{IH}$  and  $V_{IL}$  limits define the dc low and high levels for the logic detect state.



# CDCU877/CDCU877A

## 1.8-V PHASE LOCK LOOP CLOCK DRIVER

SCAS688A – JUNE 2003 – REVISED JANUARY 2004

### electrical characteristics over recommended operating free-air temperature range

PARAMETER		TEST CONDITIONS	AVDD, VDDQ	MIN	TYP	MAX	UNIT
V <sub>IJK</sub>	Input (cl inputs)	I <sub>I</sub> = 18 mA	1.7 V			-1.2	V
V <sub>OH</sub>	High-level output voltage	I <sub>OH</sub> = -100 μA	1.7 V to 1.9 V	V <sub>DDQ</sub> - 0.2			V
		I <sub>OH</sub> = -9 mA	1.7 V	1.1			
V <sub>OL</sub>	Low-level output voltage	I <sub>OL</sub> = 100 μA				0.1	V
		I <sub>OL</sub> = 9 mA	1.7 V			0.6	
I <sub>O(DL)</sub>	Low-level output current, disabled	V <sub>O(DL)</sub> = 100 mV, OE = L	1.7 V	100			μA
V <sub>OD</sub>	Differential output voltage (see Note 1)		1.7 V	0.5			V
I <sub>I</sub>	Input current	CK, $\overline{CK}$	1.9 V		±250		μA
		OE, OS, FBIN, $\overline{FBIN}$	1.9 V		±10		
I <sub>DD(LD)</sub>	Supply current, static (I <sub>DDQ</sub> + I <sub>ADD</sub> )	CK and $\overline{CK}$ = L	1.9 V			500	μA
I <sub>DD</sub>	Supply current, dynamic (I <sub>DDQ</sub> + I <sub>ADD</sub> ) (see Note 2 for C <sub>PD</sub> calculation)	CK and $\overline{CK}$ = 270 MHz, All outputs are open (not connected to a PCB)	1.9 V			135	mA
		All outputs are loaded with 2 pF and 120-Ω termination resistor	1.9 V			235	
C <sub>I</sub>	Input capacitance	CK, $\overline{CK}$	V <sub>I</sub> = V <sub>DD</sub> or GND	1.8 V	2	3	pF
		FBIN, $\overline{FBIN}$	V <sub>I</sub> = V <sub>DD</sub> or GND	1.8 V	2	3	
C <sub>I(Δ)</sub>	Change in input current	CK, $\overline{CK}$	V <sub>I</sub> = V <sub>DD</sub> or GND	1.8 V		0.25	pF
		FBIN, $\overline{FBIN}$	V <sub>I</sub> = V <sub>DD</sub> or GND	1.8 V		0.25	

- NOTES: 1. V<sub>OD</sub> is the magnitude of the difference between the true and complimentary outputs. See Figure 9 for a definition.  
 2. Total I<sub>DD</sub> = I<sub>DDQ</sub> + I<sub>ADD</sub> = f<sub>CK</sub> × C<sub>PD</sub> × V<sub>DDQ</sub>, solving for C<sub>PD</sub> = (I<sub>DDQ</sub> + I<sub>ADD</sub>) / (f<sub>CK</sub> × V<sub>DDQ</sub>) where f<sub>CK</sub> is the input frequency, V<sub>DDQ</sub> is the power supply, and C<sub>PD</sub> is the power dissipation capacitance.

### timing requirements over recommended operating free-air temperature range

PARAMETER	TEST CONDITIONS	MIN	TYP	MAX	UNIT
f <sub>CK</sub>	Clock frequency (operating, see Notes 1 and 2)	AVDD, VDD = 1.8 V ±0.1 V	10	400	MHz
f <sub>CK</sub>	Clock frequency (application, see Notes 1 and 3)	AVDD, VDD = 1.8 V ±0.1 V	160	340	MHz
t <sub>DC</sub>	Duty cycle, input clock	AVDD, VDD = 1.8 V ±0.1 V	40%	60%	
t <sub>L</sub>	Stabilization time (see Note 4)	AVDD, VDD = 1.8 V ±0.1 V		12	μs

- NOTES: 1. The PLL must be able to handle spread spectrum induced skew.  
 2. Operating clock frequency indicates a range over which the PLL must be able to lock, but in which it is not required to meet the other timing parameters (used for low speed system debug).  
 3. Application clock frequency indicates a range over which the PLL must meet all timing parameters.  
 4. Stabilization time is the time required for the integrated PLL circuit to obtain phase lock of its feedback signal to its reference signal after power up. During normal operation, the stabilization time is also the time required for the integrated PLL circuit to obtain phase lock of its feedback signal to its reference signal when CK and  $\overline{CK}$  go to a logic low state, enter the power-down mode and later return to active operation. CK and  $\overline{CK}$  may be left floating after they have been driven low for one complete clock cycle.



# CDCU877/CDCU877A

## 1.8-V PHASE LOCK LOOP CLOCK DRIVER

SCAS688A – JUNE 2003 – REVISED JANUARY 2004

**switching characteristics over recommended operating free-air temperature range (unless otherwise noted) (see Note 1)**

$$AV_{DD}, V_{DD} = 1.8 \text{ V} \pm 0.1 \text{ V}$$

PARAMETER		TEST CONDITIONS	MIN	TYP	MAX	UNIT
$t_{en}$	Enable time, OE to any $\overline{Y}$	See Figure 11			8	ns
$t_{dis}$	Disable time, OE to any $\overline{Y}$	See Figure 11			8	ns
$t_{jit}(cc+)$	Cycle-to-cycle period jitter (see Note 8)	160 MHz to 190 MHz, see Figure 4	0		40	ps
$t_{jit}(cc-)$			0		-40	
$t_{jit}(cc+)$	Cycle-to-cycle period jitter (see Note 8)	190 MHz to 340 MHz, see Figure 4	0		30	ps
$t_{jit}(cc-)$			0		-30	
$t_{(\phi)}$	Static phase offset time (see Note 2)	See Figure 5	-50		50	ps
$t_{(\phi)dyn}$	Dynamic phase offset time	See Figure 10	-15		15	ps
$t_{sk(o)}$	Output clock skew	See Figure 6			35	ps
$t_{jit(per)}$	Period jitter (see Notes 3 and 8)	160 MHz to 190 MHz, see Figure 7	-30		30	ps
		190 MHz to 340 MHz, see Figure 7	-20		20	ps
$t_{jit(hper)}$	Half-period jitter (see Notes 3 and 8)	160 MHz to 190 MHz, see Figure 8	-115		115	ps
		190 MHz to 250 MHz, see Figure 8	-70		70	ps
		250 MHz to 300 MHz, see Figure 8	-40		40	ps
		300 MHz to 340 MHz, see Figure 8	-60		60	ps
SR	Slew rate, OE	See Figure 3 and Figure 9	0.5			V/ns
	Input clock skew rate	See Figure 3 and Figure 9	1	2.5	4	V/ns
	Output clock slew rate (see Notes 4 and 5)	See Figure 3 and Figure 9	1.5	2.5	3	V/ns
$V_{OX}$	Output differential-pair cross voltage (see Note 6)	See Figure 2, CDCU877	$(V_{DDQ}/2) - 0.1$		$(V_{DDQ}/2) + 0.1$	V
		See Figure 2, CDCU877A (see Note 7) (0–85°C)	$(V_{DDQ}/2) - 0.1$		$(V_{DDQ}/2) + 0.1$	
	SSC modulation frequency		30		33	kHz
	SSC clock input frequency deviation		0%		-0.5%	
	PLL loop bandwidth		2			MHz

- NOTES:
- There are two different terminations that are used with the following tests. The load/board in Figure 2 is used to measure the input and output differential-pair cross voltage only. The load/board in Figure 3 is used to measure all other tests. For consistency, equal length cables must be used.
  - Phase static offset time does not include jitter.
  - Period jitter, half-period jitter specifications are separate specifications that must be met independently of each other.
  - The output slew rate is determined from the IBIS model into the load shown in Figure 3.
  - To eliminate the impact of input slew rates on static phase offset, the input skew rates of reference clock input CK and  $\overline{CK}$  and feedback clock inputs FBIN and  $\overline{FBIN}$  are recommended to be nearly equal. The 2.5-V/ns skew rates are shown as a recommended target. Compliance with these typical values is not mandatory if it can adequately shown that alternative characteristics meet the requirements of the registered DDR2 DIMM application.
  - Output differential-pair cross voltage specified at the DRAM clock input or the test load.
  - $V_{OX}$  of CDCU877A is on average 30 mV lower than that of CDCU877 for the same application.
  - This parameter is assured by design and characterization.



# CDCU877/CDCU877A

## 1.8-V PHASE LOCK LOOP CLOCK DRIVER

SCAS688A – JUNE 2003 – REVISED JANUARY 2004

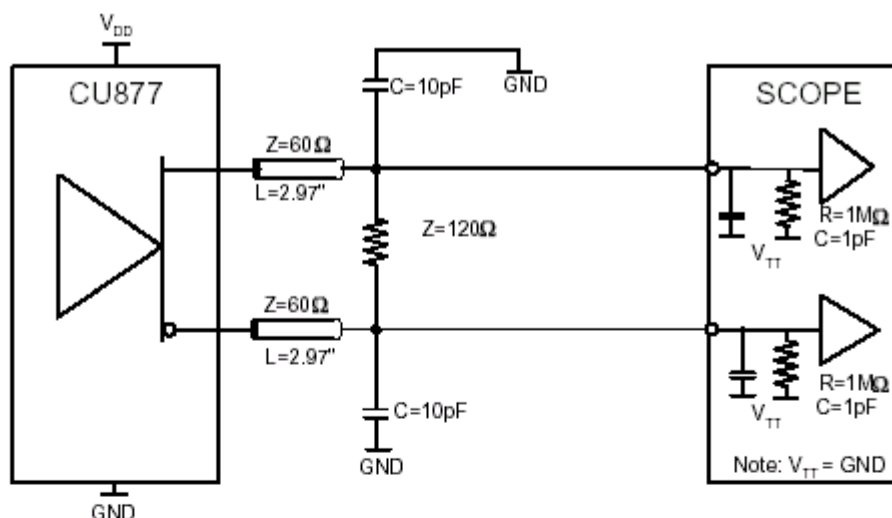

Figure 2. Output Load Test Circuit 1

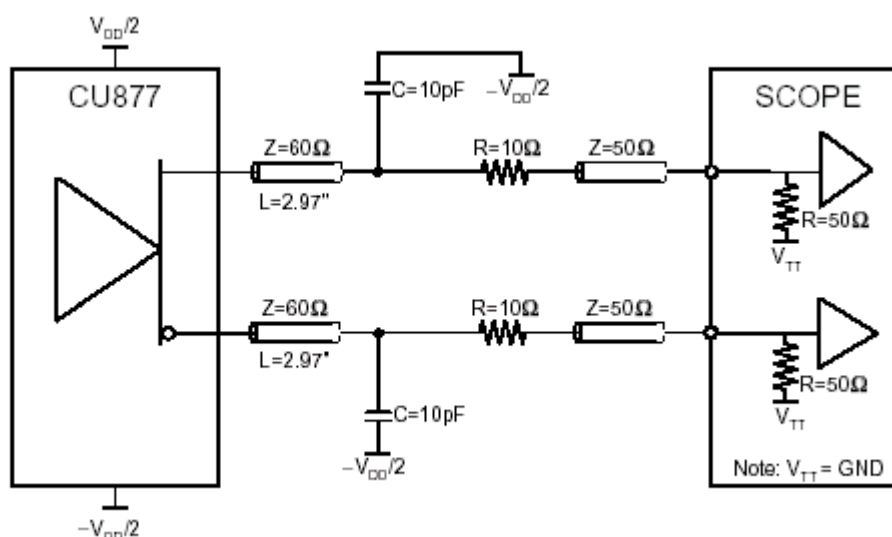

Figure 3. Output Load Test Circuit 2

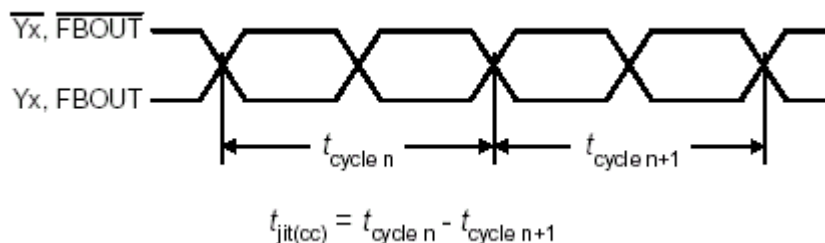
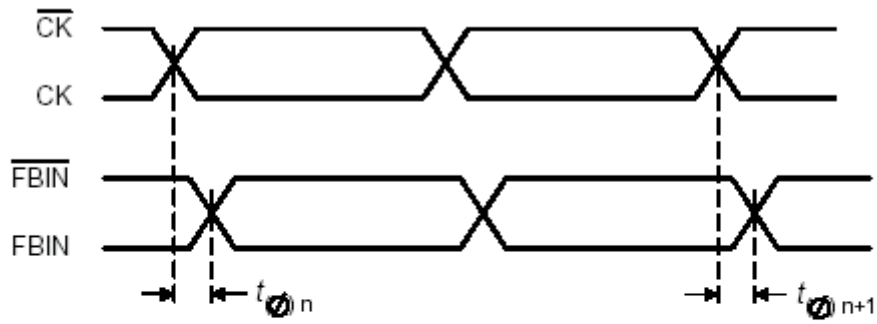

Figure 4. Cycle-To-Cycle Period Jitter



$$t_{\phi} = \frac{\sum_{n=1}^{n=N} t_{\phi n}}{N}$$

(N is a large number of samples)

(N > 1000 samples)

Figure 5. Static Phase Offset

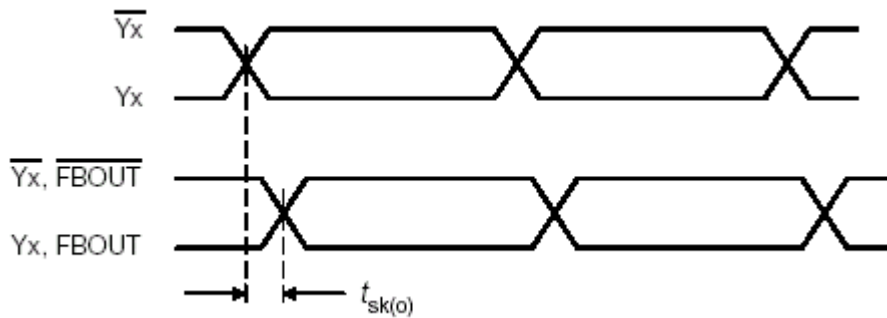
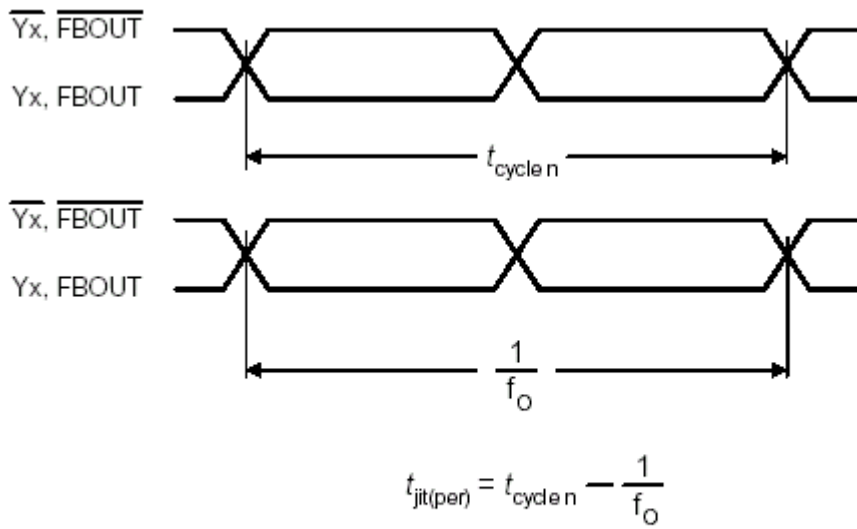

Figure 6. Output Skew

# CDCU877/CDCU877A

## 1.8-V PHASE LOCK LOOP CLOCK DRIVER

SCAS688A – JUNE 2003 – REVISED JANUARY 2004



( $f_0$  = average input frequency measured at  $\overline{CK/CK}$ )

Figure 7. Period Jitter

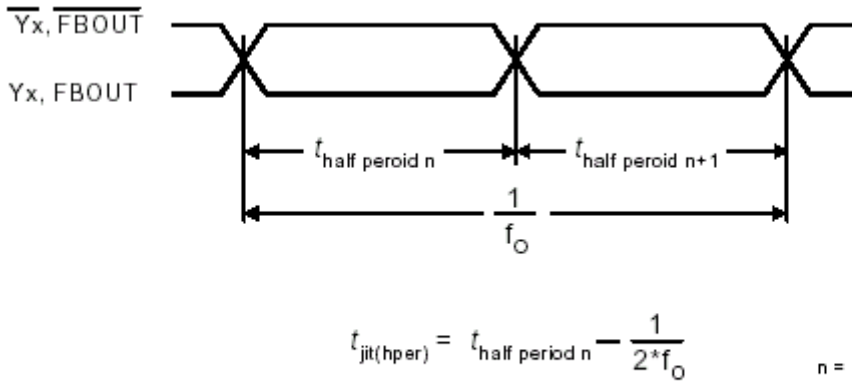

( $f_0$  = average input frequency measured at  $\overline{CK/CK}$ )

Figure 8. Half-Period Jitter

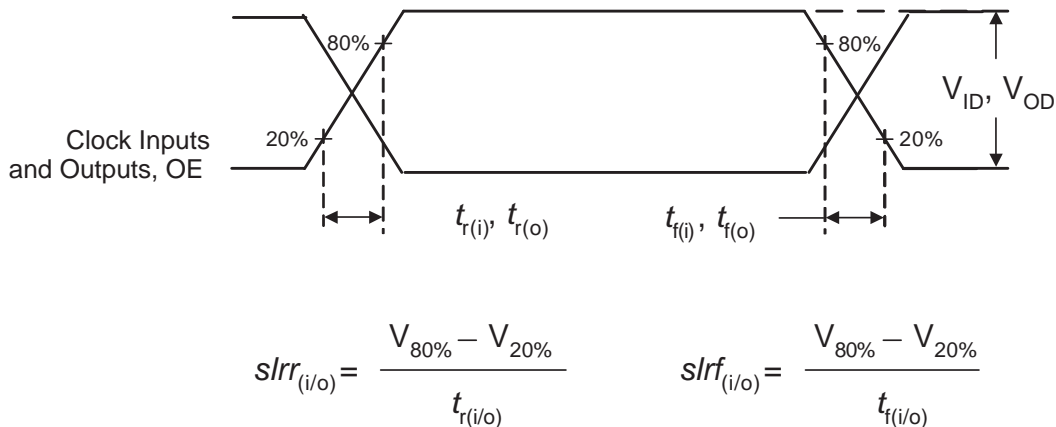

Figure 9. Input and Output Slew Rates

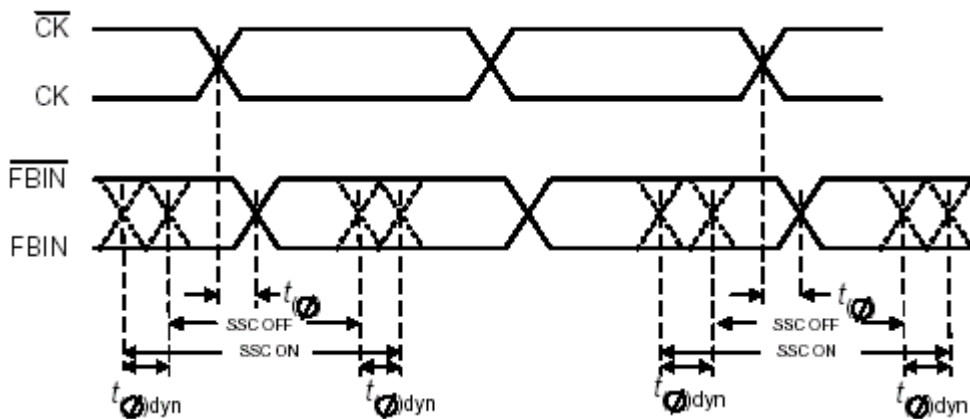

Figure 10. Dynamic Phase Offset

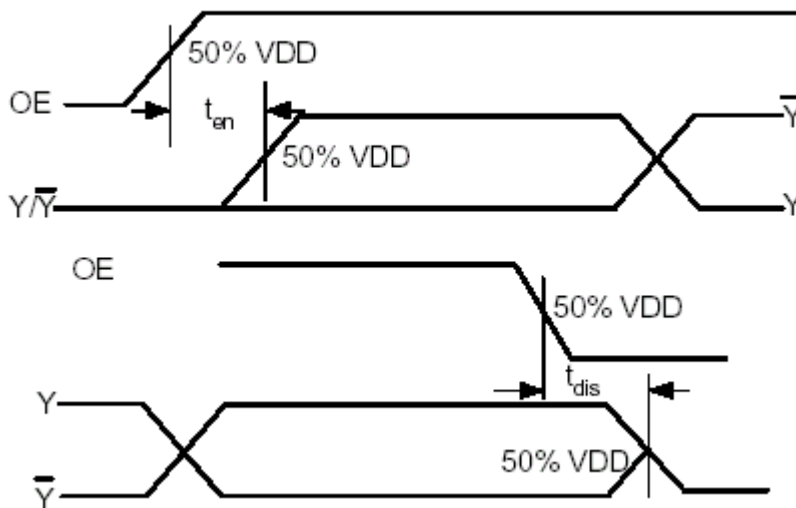

Figure 11. Time Delay Between OE and Clock Output ( $Y, \overline{Y}$ )

# CDCU877/CDCU877A

## 1.8-V PHASE LOCK LOOP CLOCK DRIVER

SCAS688A – JUNE 2003 – REVISED JANUARY 2004

### RECOMMENDED AV<sub>DD</sub> FILTERING

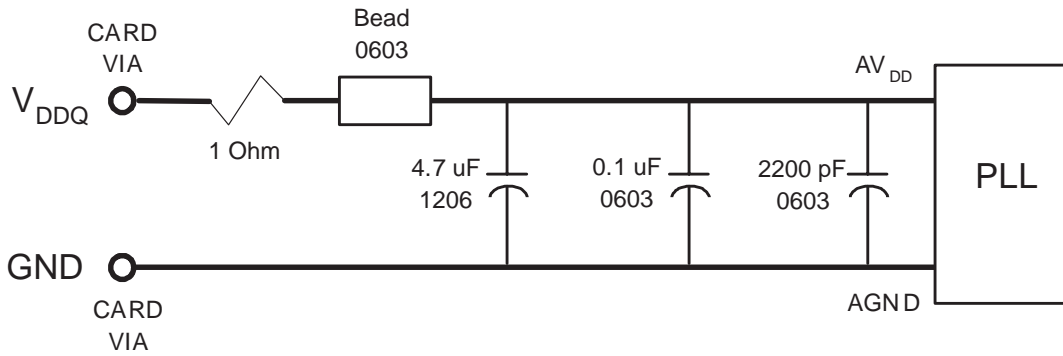

See Notes 9, 10, and 11

**Figure 12. Recommended AV<sub>DD</sub> Filtering**

- NOTES:
- Place the 2200-pF capacitor close to the PLL.
  - Use a wide trace for the PLL analog power and ground. Connect PLL and capacitors to AGND trace and connect trace to one GND via (farthest from the PLL).
  - Recommended bead: Fair-Rite PN 2506036017Y0 or equivalent (0.8  $\Omega$  dc maximum, 600  $\Omega$  at 100 MHz).

MECHANICAL DATA

GQL (R-PBGA-N52)

PLASTIC BALL GRID ARRAY

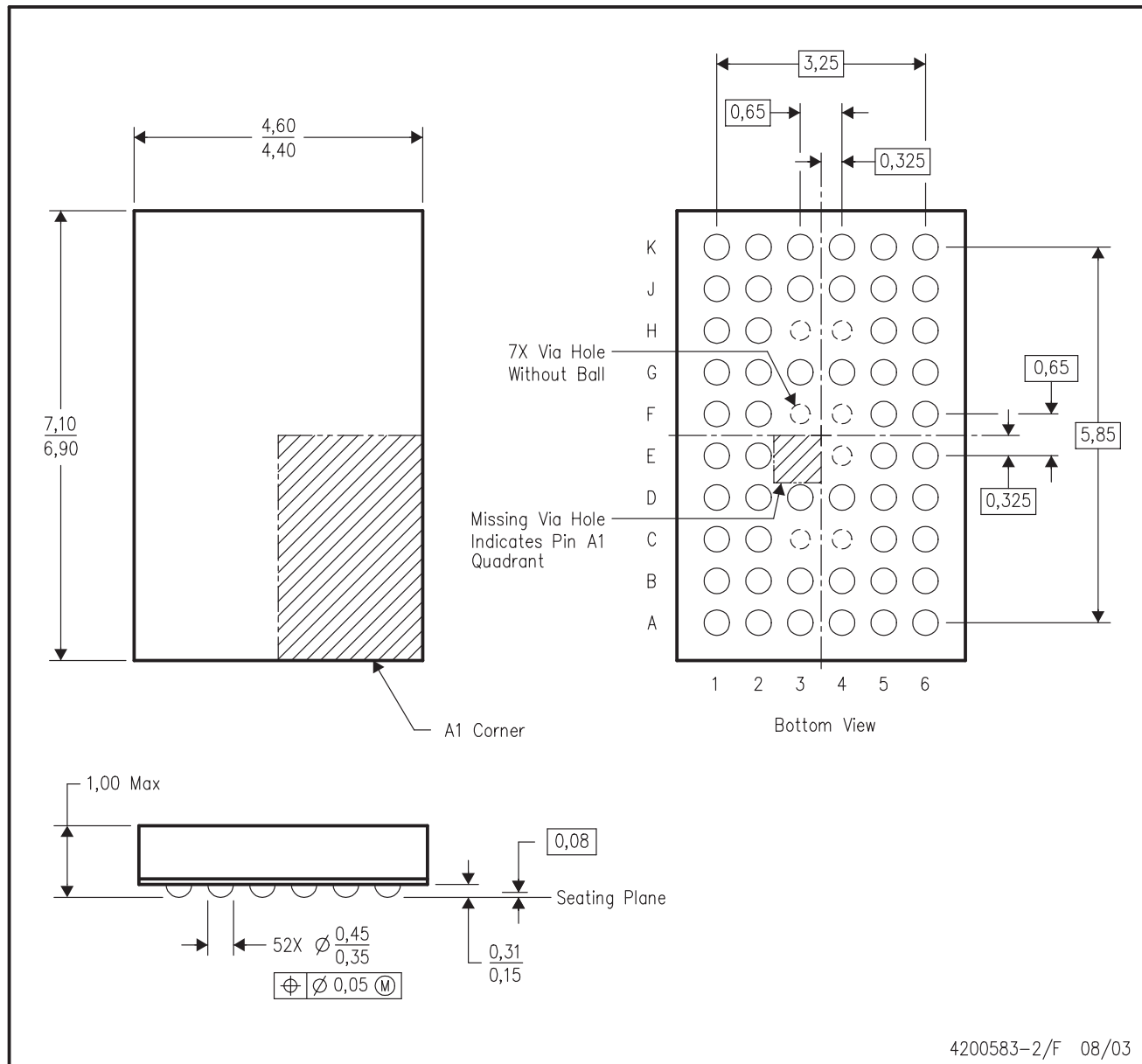

- NOTES:
- A. All linear dimensions are in millimeters.
  - B. This drawing is subject to change without notice.
  - C. MicroStar Junior™ BGA configuration
  - D. Falls within JEDEC MO-225 variation BA.
  - E. This package is tin-lead (SnPb).

MicroStar Junior is a trademark of Texas Instruments.



THERMAL PAD MECHANICAL DATA

RTB (S-PQFP-N40)

PLASTIC QUAD FLATPACK

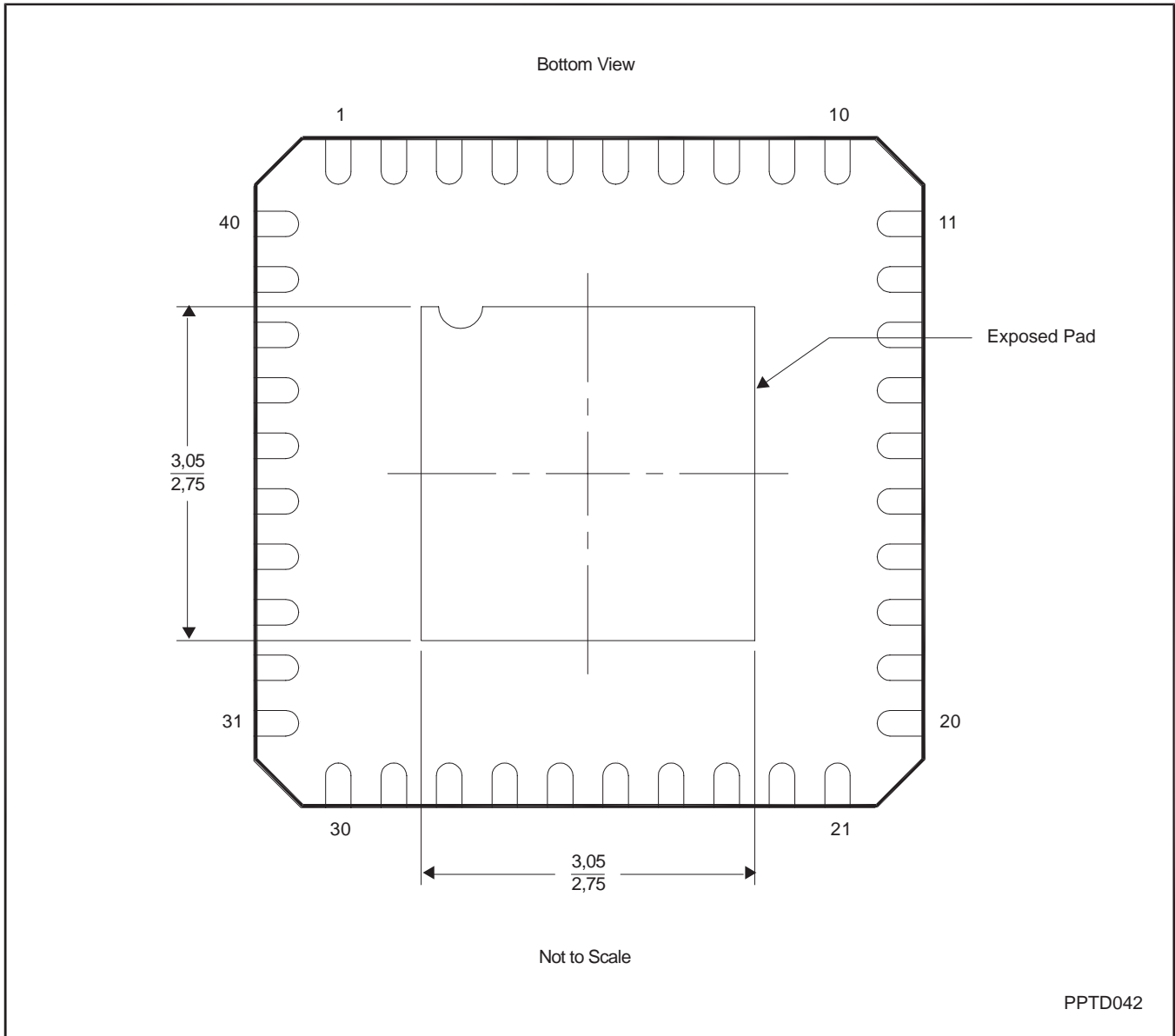

- NOTES: A. All linear dimensions are in millimeters.  
B. This drawing is subject to change without notice.  
C. QFN (Quad Flatpack No-Lead) Package configuration.

## IMPORTANT NOTICE

Texas Instruments Incorporated and its subsidiaries (TI) reserve the right to make corrections, modifications, enhancements, improvements, and other changes to its products and services at any time and to discontinue any product or service without notice. Customers should obtain the latest relevant information before placing orders and should verify that such information is current and complete. All products are sold subject to TI's terms and conditions of sale supplied at the time of order acknowledgment.

TI warrants performance of its hardware products to the specifications applicable at the time of sale in accordance with TI's standard warranty. Testing and other quality control techniques are used to the extent TI deems necessary to support this warranty. Except where mandated by government requirements, testing of all parameters of each product is not necessarily performed.

TI assumes no liability for applications assistance or customer product design. Customers are responsible for their products and applications using TI components. To minimize the risks associated with customer products and applications, customers should provide adequate design and operating safeguards.

TI does not warrant or represent that any license, either express or implied, is granted under any TI patent right, copyright, mask work right, or other TI intellectual property right relating to any combination, machine, or process in which TI products or services are used. Information published by TI regarding third-party products or services does not constitute a license from TI to use such products or services or a warranty or endorsement thereof. Use of such information may require a license from a third party under the patents or other intellectual property of the third party, or a license from TI under the patents or other intellectual property of TI.

Reproduction of information in TI data books or data sheets is permissible only if reproduction is without alteration and is accompanied by all associated warranties, conditions, limitations, and notices. Reproduction of this information with alteration is an unfair and deceptive business practice. TI is not responsible or liable for such altered documentation.

Resale of TI products or services with statements different from or beyond the parameters stated by TI for that product or service voids all express and any implied warranties for the associated TI product or service and is an unfair and deceptive business practice. TI is not responsible or liable for any such statements.

Following are URLs where you can obtain information on other Texas Instruments products and application solutions:

<b>Products</b>		<b>Applications</b>	
Amplifiers	<a href="http://amplifier.ti.com">amplifier.ti.com</a>	Audio	<a href="http://www.ti.com/audio">www.ti.com/audio</a>
Data Converters	<a href="http://dataconverter.ti.com">dataconverter.ti.com</a>	Automotive	<a href="http://www.ti.com/automotive">www.ti.com/automotive</a>
DSP	<a href="http://dsp.ti.com">dsp.ti.com</a>	Broadband	<a href="http://www.ti.com/broadband">www.ti.com/broadband</a>
Interface	<a href="http://interface.ti.com">interface.ti.com</a>	Digital Control	<a href="http://www.ti.com/digitalcontrol">www.ti.com/digitalcontrol</a>
Logic	<a href="http://logic.ti.com">logic.ti.com</a>	Military	<a href="http://www.ti.com/military">www.ti.com/military</a>
Power Mgmt	<a href="http://power.ti.com">power.ti.com</a>	Optical Networking	<a href="http://www.ti.com/opticalnetwork">www.ti.com/opticalnetwork</a>
Microcontrollers	<a href="http://microcontroller.ti.com">microcontroller.ti.com</a>	Security	<a href="http://www.ti.com/security">www.ti.com/security</a>
		Telephony	<a href="http://www.ti.com/telephony">www.ti.com/telephony</a>
		Video & Imaging	<a href="http://www.ti.com/video">www.ti.com/video</a>
		Wireless	<a href="http://www.ti.com/wireless">www.ti.com/wireless</a>

Mailing Address: Texas Instruments  
Post Office Box 655303 Dallas, Texas 75265

## Looking for pricing, stock, or lifecycle information?

Click below to explore more details on WIN SOURCE:

 [View CDCU877AGQLR](#) on WIN SOURCE

 [Texas Instruments](#) Information

## Optimize Your Supply Chain with WIN SOURCE Solutions

-  Global Sourcing Solution
-  Obsolete Management
-  Cost Control Management
-  Shortage Management
-  Alternative Solution
-  Excess Inventory Management