



**THE DATASHEET OF
CDCU2A877ZQLR**



1.8-V PHASE LOCK LOOP CLOCK DRIVER

FEATURES

- 1.8-V/1.9-V Phase Lock Loop Clock Driver for Double Data Rate (DDR II) Applications
- Spread Spectrum Clock Compatible
- Operating Frequency: 125 MHz to 410 MHz
- Application Frequency: 160 MHz to 410 MHz
- Low Jitter (Cycle-Cycle): ± 40 ps
- Low Output Skew: 35 ps
- Stabilization Time < 6 μ s
- Distributes One Differential Clock Input to 10 Differential Outputs
- High-Drive Version of CDCUA877
- 52-Ball mBGA (MicroStar Junior™ BGA, 0,65-mm pitch)
- External Feedback Pins (FBIN, $\overline{\text{FBIN}}$) are Used to Synchronize the Outputs to the Input Clocks
- Meets or Exceeds CUA877/CUA878 Specification PLL Standard for PC2-3200/4300/5300/6400
- Fail-Safe Inputs

DESCRIPTION

The CDCU2A877 is a high-performance, low-jitter, low-skew, zero-delay buffer that distributes a differential clock input pair (CK, $\overline{\text{CK}}$) to 10 differential pairs of clock outputs (Y_n , $\overline{\text{Y}}_n$) and to one differential pair of feedback clock outputs (FBOU, $\overline{\text{FBOU}}$). The clock outputs are controlled by the input clocks (CK, $\overline{\text{CK}}$), the feedback clocks (FBIN, $\overline{\text{FBIN}}$), the LVCMOS control pins (OE, OS), and the analog power input (AV_{DD}). When OE is low, the clock outputs, except FBOU/ $\overline{\text{FBOU}}$, are disabled while the internal PLL continues to maintain its locked-in frequency. OS (output select) is a program pin that must be tied to GND or V_{DD} . When OS is high, OE functions as previously described. When OS and OE are both low, OE has no effect on $\text{Y}_7/\overline{\text{Y}}_7$, they are free running. When AV_{DD} is grounded, the PLL is turned off and bypassed for test purposes.

When both clock inputs (CK, $\overline{\text{CK}}$) are logic low, the device enters in a low power mode. An input logic detection circuit on the differential inputs, independent from input buffers, detects the logic low level and performs in a low power state where all outputs, the feedback, and the PLL are off. When the clock inputs transition from being logic low to being differential signals, the PLL turns back on, the inputs and the outputs are enabled, and the PLL obtains phase lock between the feedback clock pair (FBIN, $\overline{\text{FBIN}}$) and the clock input pair (CK, $\overline{\text{CK}}$) within the specified stabilization time.

The CDCU2A877 is able to track spread spectrum clocking (SSC) for reduced EMI. This device operates from 0°C to 70°C.

AVAILABLE OPTIONS

T_A	52-Ball BGA ⁽¹⁾
0°C to 70°C	CDCU2A877ZQL

- (1) For the most current package and ordering information, see the Package Option Addendum at the end of this document, or see the TI website at www.ti.com.



Please be aware that an important notice concerning availability, standard warranty, and use in critical applications of Texas Instruments semiconductor products and disclaimers thereto appears at the end of this data sheet.

MicroStar Junior is a trademark of Texas Instruments.

MicroStar™ Junior (GQL) Package
(TOP VIEW)

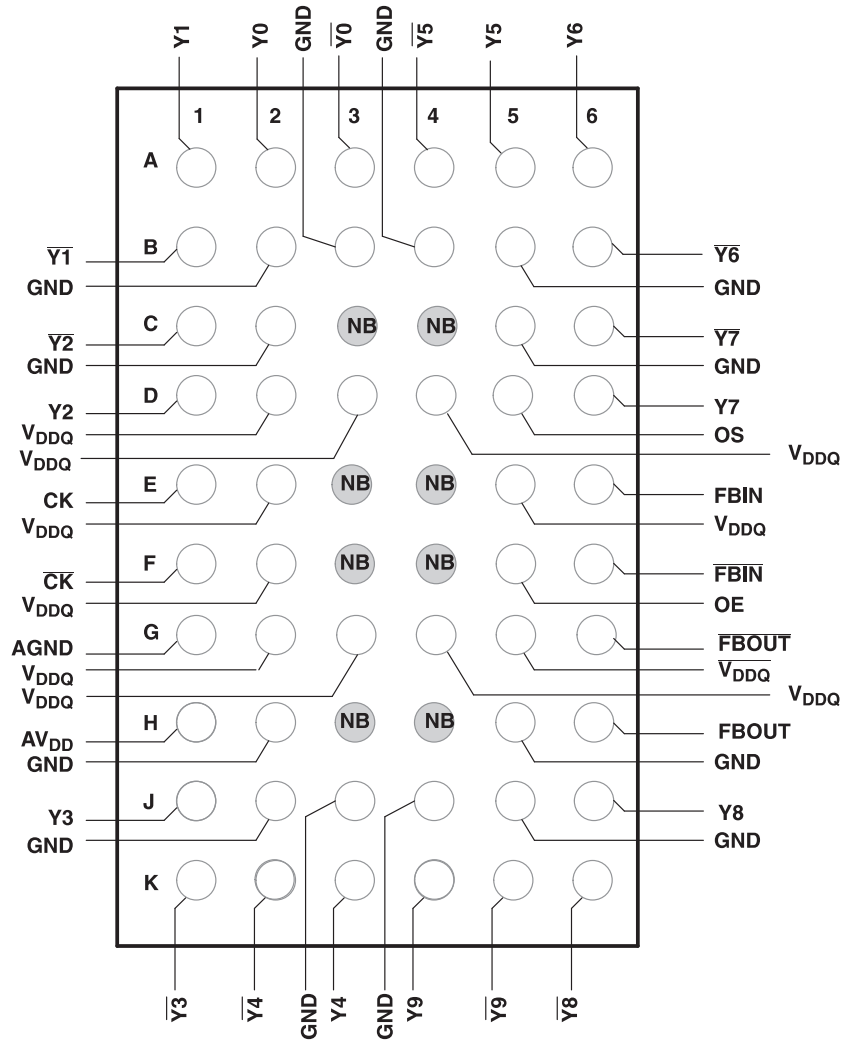

NC - No Connection
NB - No Ball

Table 1. Terminal Functions

NAME	BGA	MLF	I/O	DESCRIPTION
AGND	G1	7		Analog ground
AV _{DD}	H1	8		Analog power
CK	E1	4	I	Clock input with a (10 kΩ to 100 kΩ) pulldown resistor
$\overline{\text{CK}}$	F1	5	I	Complementary clock input with a (10 kΩ to 100 kΩ) pulldown resistor
FBIN	E6	27	I	Feedback clock input
$\overline{\text{FBIN}}$	F6	26	I	Complementary feedback clock input
FBOUT	H6	24	O	Feedback clock output
$\overline{\text{FBOUT}}$	G6	25	O	Complementary feedback clock output
OE	F5	22	I	Output enable (asynchronous)
OS	D5	21	I	Output select (tied to GND or VDD)
GND	B2, B3, B4, B5, C2, C5, H2, H5, J2, J3, J4, J5	10		Ground
V _{DDQ}	D2, D3, D4, E2, E5, F2, G2, G3, G4, G5	1, 6, 9, 15, 20, 23, 28, 31, 36		Logic and output power
Y[0:9]	A2, A1, D1, J1, K3, A5, A6, D6, J6, K4	38, 39, 3, 11, 14, 34, 33, 29, 19, 16	O	Clock outputs
$\overline{\text{Y}}[0:9]$	A3, B1, C1, K1, K2, A4, B6, C6, K6, K5	37, 40, 2, 12, 13, 35, 32, 30, 18, 17	O	Complementary clock outputs

Table 2. Function Table

INPUTS					OUTPUTS				PLL
AV _{DD}	OE	OS	CK	$\overline{\text{CK}}$	Y	$\overline{\text{Y}}$	FBOUT	$\overline{\text{FBOUT}}$	
GND	H	X	L	H	L		L	H	Bypassed/Off
GND	H	X	H	L	H		H	L	Bypassed/Off
GND	L	H	L	H	L _Z	L _Z	L	H	Bypassed/Off
GND	L	L	H	L	L _Z Y7 Active	L _Z $\overline{\text{Y7}}$ Active	H	L	Bypassed/Off
1.8 V Nomnal	L	H	L	H	L _Z	L _Z	L	H	On
1.8 V Nomnal	L	L	H	L	L _Z Y7 Active	L _Z $\overline{\text{Y7}}$ Active	H	L	On
1.8 V Nomnal	H	X	L	H	L	H	L	H	On
1.8 V Nomnal	H	X	H	L	H	L	H	L	On
1.8 V Nomnal	X	X	LH	L	L _Z	L _Z	L _Z	L _Z	Off
X	X	X	H	H	Reserved				

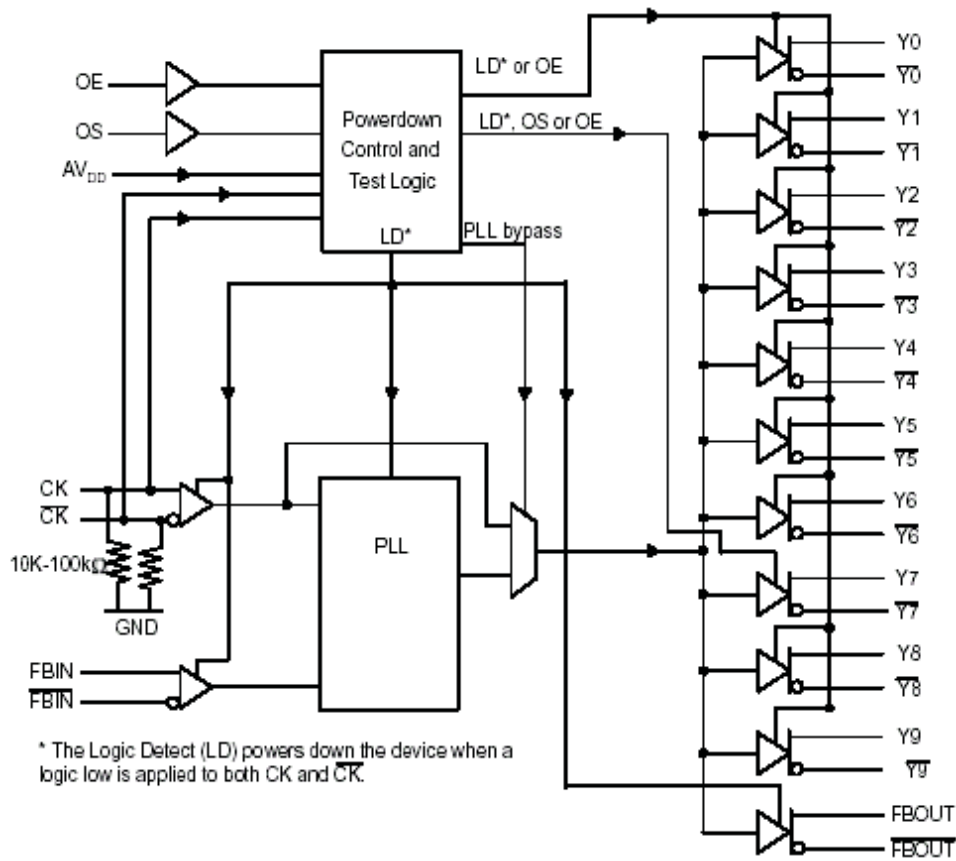

Figure 1. Logic Diagram (Positive Logic)

ABSOLUTE MAXIMUM RATINGS

over operating free-air temperature range (unless otherwise noted)⁽¹⁾

		VALUE	UNIT
V _{DDQ} A _{VDD}	Supply voltage range	-0.5 to 2.5	V
V _I	Input voltage range ^{(2) (3)}	-0.5 to V _{DDQ} + 0.5	V
V _O	Output voltage range ^{(2) (3)}	-0.5 to V _{DDQ} + 0.5	V
I _{IK}	Input clamp current, (V _I < 0 or V _I > V _{DDQ})	±50	mA
I _{OK}	Output clamp voltage, (V _O < 0 or V _O > V _{DDQ})	±50	mA
I _O	Continuous output current, (V _O = 0 to V _{DDQ})	±50	mA
I _{DDC}	Continuous current through each V _{DDQ} or GND	±100	mA
R _{θJA}	Thermal resistance, junction-to-ambient ⁽⁴⁾	No airflow	151.9
		Airflow 150 ft/min	146.1
R _{θJC}	Thermal resistance, junction-to-case ⁽⁴⁾	No airflow	102.4
T _{stg}	Storage temperature range	-65 to 150	°C

(1) Stresses beyond those listed under *absolute maximum ratings* may cause permanent damage to the device. These are stress ratings only, and functional operation of the device at these or any other conditions beyond those indicated under *recommended operating conditions* is not implied. Exposure to absolute-maximum-rated conditions for extended periods may affect device reliability.

(2) The input and output voltage ratings may be exceeded if the input and output clamp-current ratings are observed.

(3) This value is limited to 2.5 V maximum.

(4) The package thermal impedance is calculated in accordance with JESD51 and JEDEC2S1P (high-k board).

RECOMMENDED OPERATING CONDITIONS

		MIN	NOM	MAX	UNIT
V _{DDQ}	Output supply voltage	1.7	1.8	1.9	V
AV _{DD}	Supply voltage ⁽¹⁾	V _{DDQ}			
V _{IL}	Low-level input voltage ⁽²⁾			0.35 × V _{DDQ}	V
V _{IH}	High-level input voltage ⁽²⁾		0.65 × V _{DDQ}		V
I _{OH}	High-level output current (see Figure 2)			–18	mA
I _{OL}	Low-level output current (see Figure 2)			18	mA
V _{IX}	Input differential-pair cross voltage	(V _{DDQ} /2)–0.15		(V _{DDQ} /2)+0.15	V
V _I	Input voltage level	–0.3		V _{DDQ} +0.3	V
V _{ID}	Input differential voltage ⁽²⁾ (see Figure 10)	DC	0.3	V _{DDQ} +0.4	V
		AC	0.6	V _{DDQ} +0.4	V
T _A	Operating free-air temperature	0		70	°C

(1) The PLL is turned off and bypassed for test purposes when AV_{DD} is grounded. During this test mode, V_{DDQ} remains within the recommended operating conditions and no timing parameters are ensured.

(2) V_{ID} is the magnitude of the difference between the input level on CK and the input level on \overline{CK} , see Figure 10 for definition. The CK and \overline{CK} V_{IH} and V_{IL} limits define the dc low and high levels for the logic detect state.

ELECTRICAL CHARACTERISTICS

over recommended operating free-air temperature range

PARAMETER		TEST CONDITIONS	V_{DD} , V_{DDG}	MIN	TYP	MAX	UNIT
V_{IK}	Input (cl inputs)	$I_I = -18$ mA	1.7 V			-1.2	V
V_{OH}	High-level output voltage	$I_{OH} = -100 = A$	1.7 V to 1.9 V	V_{DDQ} - 0.2			V
		$I_{OH} = -18$ mA	1.7 V	1.1			
V_{OL}	Low-level output voltage	$I_{OL} = 100$ μ A				0.1	V
		$I_{OL} = 18$ mA	1.7 V			0.6	
$I_{O(DL)}$	Low-level output current, disabled	$V_{O(DL)} = 100$ mV, OE = L	1.7 V	100			μ A
V_{OD}	Differential output voltage ⁽¹⁾		1.7 V	0.6			V
I_I	Input current	CK, \overline{CK}	1.9 V			± 250	μ A
		OE, OS, FBIN, \overline{FBIN}	1.9 V			± 10	
$I_{DD(LD)}$	Supply current, static ($I_{DDQ} + I_{ADD}$)	CK and $\overline{CK} = L$	1.9 V			500	μ A
I_{DD}	Supply current, dynamic ($I_{DDQ} + I_{ADD}$) (see ⁽²⁾ for C_{PD} calculation)	CK and $\overline{CK} = 410$ MHz, All outputs are open (not connected to a PCB)	1.9 V			300	mA
		All outputs are loaded with 2 pF and 120- Ω termination resistor, CK and $\overline{CK} = 410$ MHz	1.9 V			325	mA
C_I	Input capacitance	CK, \overline{CK}	$V_I = V_{DD}$ or GND	1.8 V	2	3	pF
		FBIN, \overline{FBIN}	$V_I = V_{DD}$ or GND	1.8 V	2	3	
$C_{I(\Delta)}$	Change in input current	CK, \overline{CK}	$V_I = V_{DD}$ or GND	1.8 V		0.25	pF
		FBIN, \overline{FBIN}	$V_I = V_{DD}$ or GND	1.8 V		0.25	

(1) V_{OD} is the magnitude of the difference between the true and complimentary outputs. See Figure 10 for a definition.

(2) Total $I_{DD} = I_{DDQ} + I_{ADD} = f_{CK} \times C_{PD} \times V_{DDQ}$, solving for $C_{PD} = (I_{DDQ} + I_{ADD}) / (f_{CK} \times V_{DDQ})$ where f_{CK} is the input frequency, V_{DDQ} is the power supply, and C_{PD} is the power dissipation capacitance.

TIMING REQUIREMENTS

over recommended operating free-air temperature range

PARAMETER	TEST CONDITIONS	MIN	TYP	MAX	UNIT
f_{CK}	Clock frequency (operating) ⁽¹⁾ ⁽²⁾		125	410	MHz
f_{CK}	Clock frequency (application) ⁽¹⁾ ⁽³⁾		160	410	MHz
t_{DC}	Duty cycle, input clock		40%	60%	
t_L	Stabilization time ⁽⁴⁾			6	μ s

(1) The PLL must be able to handle spread spectrum induced skew.

(2) Operating clock frequency indicates a range over which the PLL must be able to lock, but in which it is not required to meet the other timing parameters (used for low speed system debug).

(3) Application clock frequency indicates a range over which the PLL must meet all timing parameters.

(4) Stabilization time is the time required for the integrated PLL circuit to obtain phase lock of its feedback signal to its reference signal, within the value specified by the static phase offset $t_{(\phi)}$, after power up. During normal operation, the stabilization time is also the time required for the integrated PLL circuit to obtain phase lock of its feedback signal to its reference signal when CK and \overline{CK} go to a logic low state, enter the power-down mode, and later return to active operation. CK and \overline{CK} may be left floating after they have been driven low for one complete clock cycle.

SWITCHING CHARACTERISTICS

over recommended operating free-air temperature range (unless otherwise noted)⁽¹⁾

PARAMETER		TEST CONDITIONS	MIN	TYP	MAX	UNIT
t_{en}	Enable time, OE to any $\overline{Y}/\overline{Y}$	See Figure 12			8	ns
t_{dis}	Disable time, OE to any $\overline{Y}/\overline{Y}$	See Figure 12			8	ns
$t_{jit(cc+)}$	Cycle-to-cycle period jitter ⁽²⁾	160 MHz to 410 MHz, See Figure 5	0		40	ps
$t_{jit(cc-)}$			0		-40	
$t_{(\phi)}$	Static phase offset time ⁽³⁾	See Figure 6	-50		50	ps
$t_{(\phi)dyn}$	Dynamic phase offset time, ⁽⁴⁾	See Figure 11	-20		20	ps
$t_{sk(o)}$	Output clock skew ⁽⁴⁾	See Figure 7			35	ps
$t_{jit(per)}$	Period jitter ^{(5) (2)}	160 MHz to 270 MHz, See Figure 8	-30		30	ps
		271 MHz to 410 MHz, See Figure 8	-20		20	
$t_{jit(hper)}$	Half-period jitter ^{(5) (2)}	160 MHz to 270 MHz, See Figure 9	-75		75	ps
		271 MHz to 410 MHz, See Figure 9	-50		50	
$\Sigma t_{(su)}$	$ t_{jit(per)} + t_{(\phi)dyn} + t_{sk(o)}$ ⁽⁶⁾	271 MHz to 410 MHz			80	ps
$\Sigma t_{(h)}$	$ t_{(\phi)dyn} + t_{sk(o)}$ ⁽⁶⁾	271 MHz to 410 MHz			60	ps
SR	Slew rate, OE	See Figure 3 and Figure 8	0.5			V/ns
	Input clock skew rate	See Figure 3 and Figure 8	1	2.5	4	
	Output clock slew rate ⁽⁷⁾⁽⁸⁾	See Figure 3 and Figure 8	1.5	2.5	3	
V_{OX}	Output differential-pair cross voltage ⁽⁹⁾	See Figure 2	$(V_{DDQ}/2) - 0.1$	$(V_{DDQ}/2) + 0.1$		V
	SSC modulation frequency		30		33	kHz
	SSC clock input frequency deviation		0%		-0.5%	
	PLL loop bandwidth		2			MHz

- (1) There are two different terminations that are used with the following tests. The load/board in [Figure 2](#) is used to measure the input and output differential-pair cross voltage only. The load/board in [Figure 3](#) is used to measure all other tests. For consistency, equal length cables must be used.
- (2) This parameter is assured by design and characterization.
- (3) Phase static offset time does not include jitter.
- (4) For full frequency range of 160MHz to 410MHz.
- (5) Period jitter, half-period jitter specifications are separate specifications that must be met independently of each other.
- (6) In the frequency range of 271 MHz to 410 MHz, the minimum and maximum values of $t_{jit(per)}$ and $t_{(\phi)dyn}$ and the maximum value for $t_{sk(o)}$ must not exceed the corresponding minimum and maximum values of the 160 MHz to 270 MHz range. In addition, the sum of the specified values for $|t_{jit(per)}|$, $|t_{(\phi)dyn}|$, and $t_{sk(o)}$ must meet the requirements for the $\Sigma t_{(su)}$ and the sum of the specified values for $|t_{(\phi)dyn}|$ and $t_{sk(o)}$ must meet the requirements for the $\Sigma t_{(h)}$.
- (7) The output slew rate is determined from the IBIS model into the load shown in [Figure 4](#).
- (8) To eliminate the impact of input slew rates on static phase offset, the input skew rates of reference clock input CK and \overline{CK} and feedback clock inputs FBIN and \overline{FBIN} are recommended to be nearly equal. The 2.5-V/ns skew rates are shown as a recommended target. Compliance with these typical values is not mandatory if it can adequately shown that alternative characteristics meet the requirements of the registered DDR2 DIMM application.
- (9) Output differential-pair cross voltage specified at the DRAM clock input or the test load.

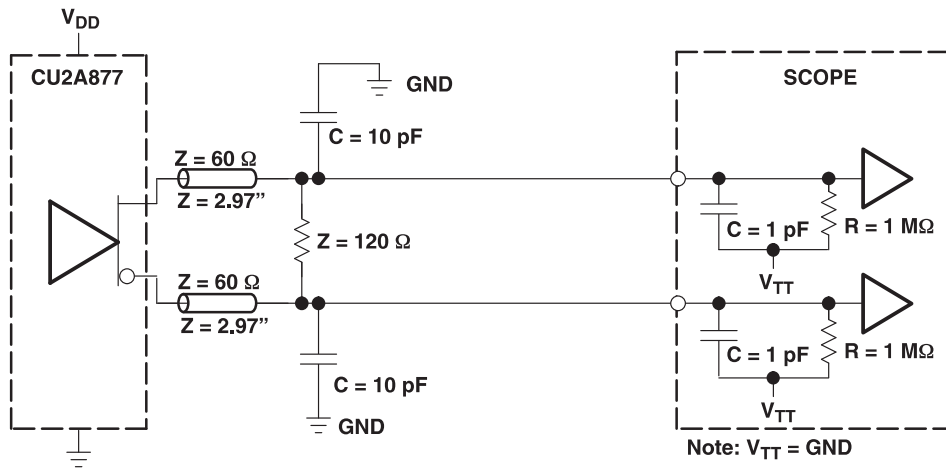

Figure 2. Output Load Test Circuit 1 (Using High-Impedance Probe)

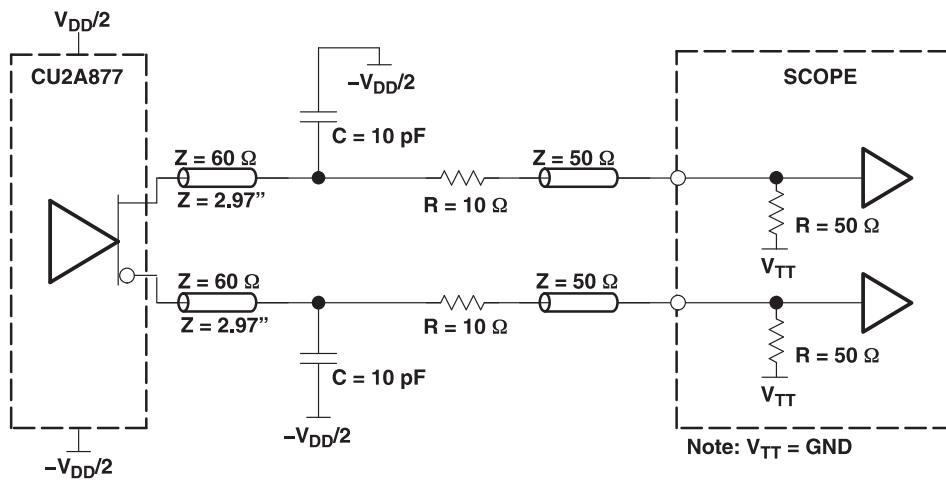

Figure 3. Output Load Test Circuit 2 (Using SMA Coaxial Cable)

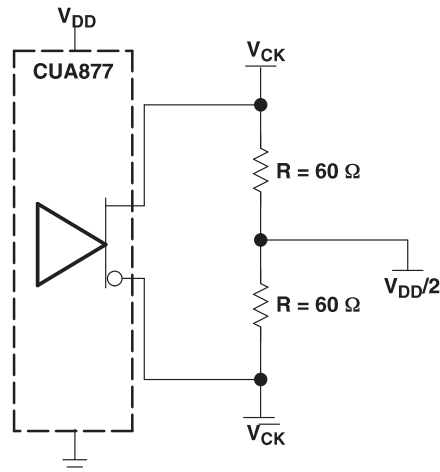

Figure 4. IBIS Model Output Load

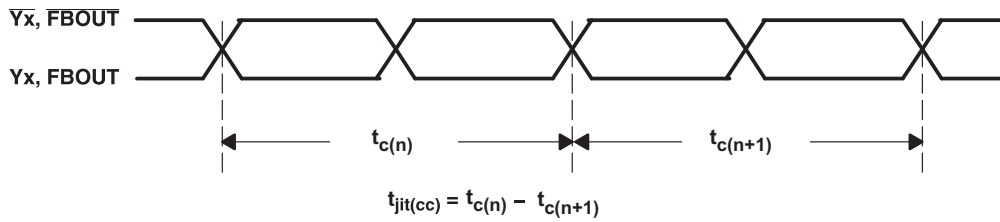

Figure 5. Cycle-To-Cycle Period Jitter

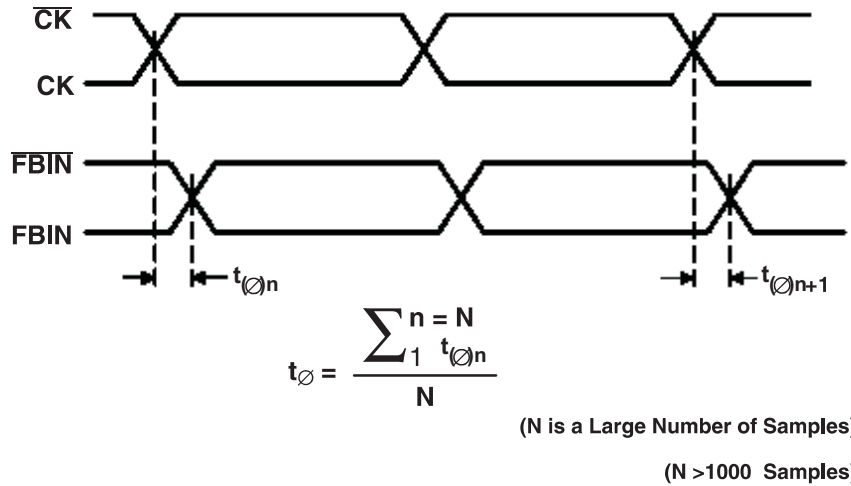

Figure 6. Static Phase Offset

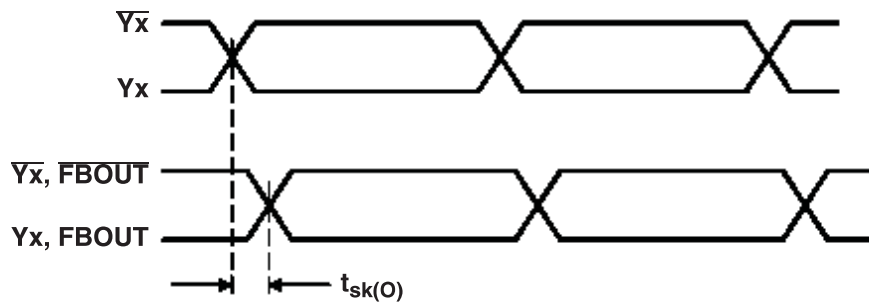
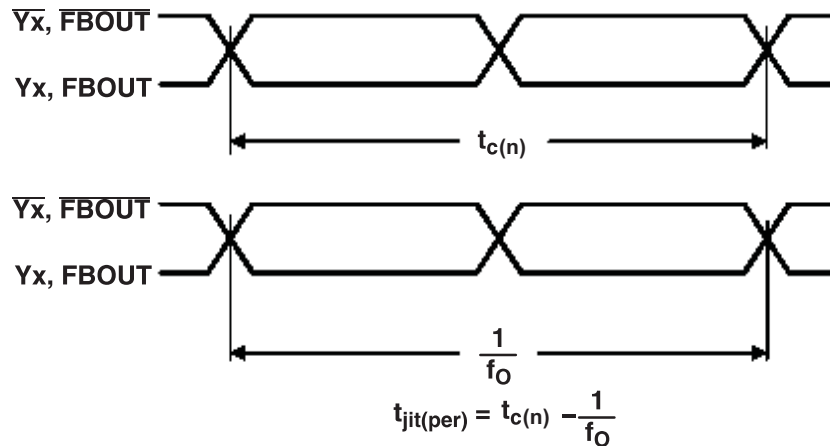
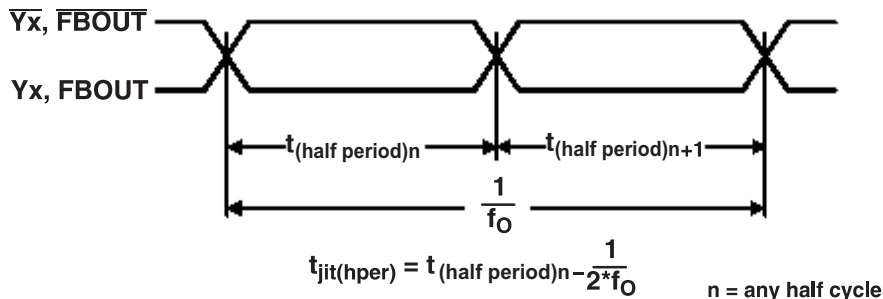

Figure 7. Output Skew



f_0 = Average Input Frequency Measured at CK/CK

Figure 8. Period Jitter



(f_0 = Average Input Frequency Measured at CK/CK)

Figure 9. Half-Period Jitter

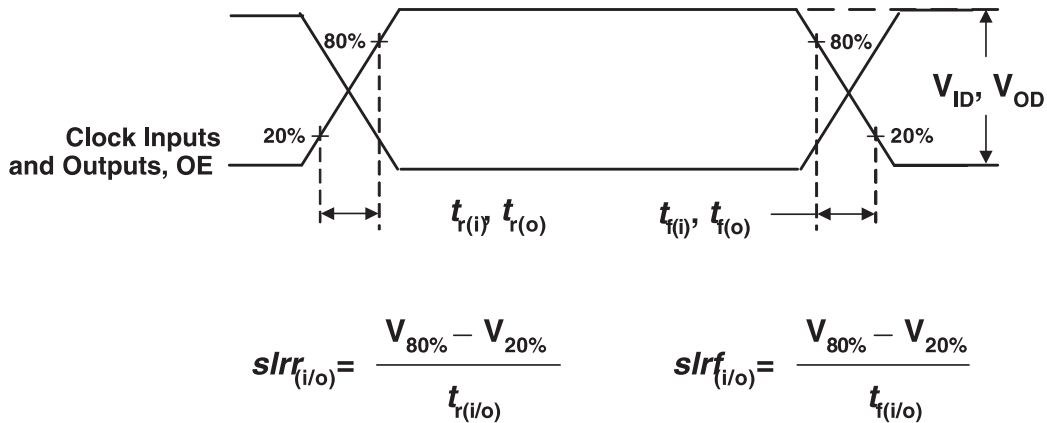

Figure 10. Input and Output Slew Rates

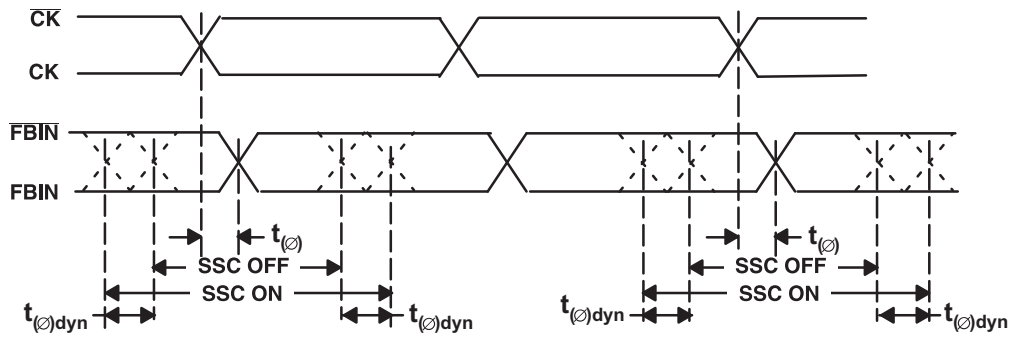

Figure 11. Dynamic Phase Offset

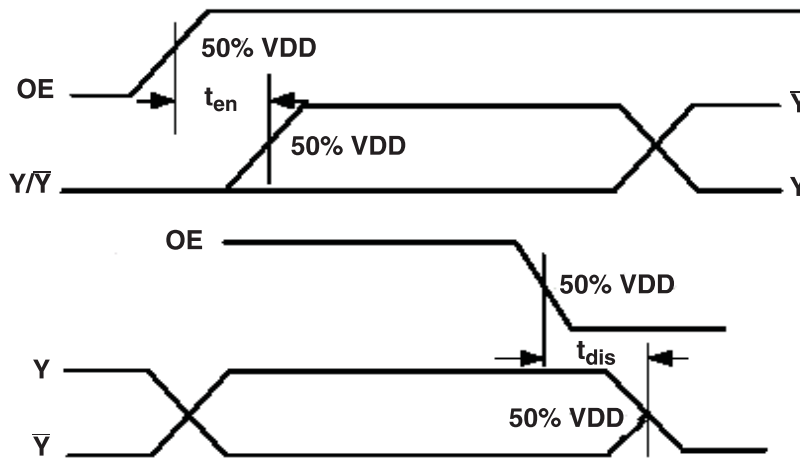
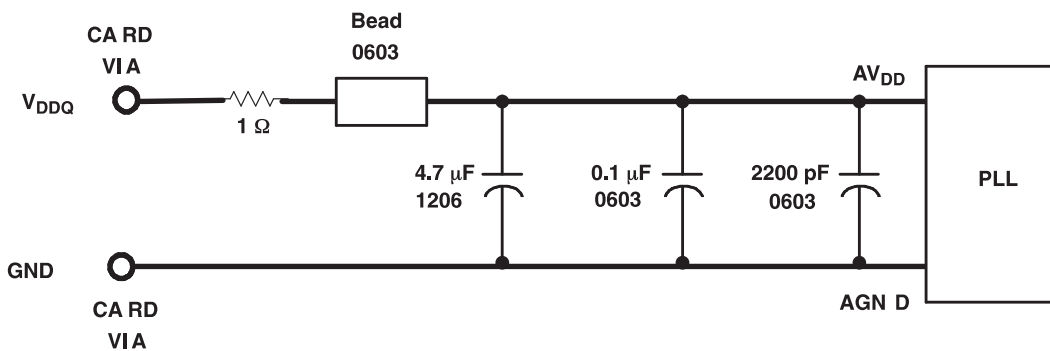

Figure 12. Time Delay Between OE and Clock Output (Y, \bar{Y})



- Place the 2200-pF capacitor close to the PLL.
- Use a wide trace for the PLL analog power and ground. Connect PLL and capacitors to AGND trace and connect trace to one GND via (farthest from the PLL).
- Recommended bead: Fair-Rite PN 2506036017Y0 or equivalent (0.8Ω dc maximum, 600Ω at 100 MHz).

Figure 13. Recommended AV_{DD} Filtering

PACKAGING INFORMATION

Orderable Device	Status ⁽¹⁾	Package Type	Package Drawing	Pins	Package Qty	Eco Plan ⁽²⁾	Lead/Ball Finish	MSL Peak Temp ⁽³⁾
CDCU2A877ZQLR	ACTIVE	BGA MI CROSTA R JUNI OR	ZQL	52	1000	Green (RoHS & no Sb/Br)	SNAGCU	Level-2-260C-1 YEAR
CDCU2A877ZQLT	ACTIVE	BGA MI CROSTA R JUNI OR	ZQL	52	250	Green (RoHS & no Sb/Br)	SNAGCU	Level-2-260C-1 YEAR

⁽¹⁾ The marketing status values are defined as follows:

ACTIVE: Product device recommended for new designs.

LIFEBUY: TI has announced that the device will be discontinued, and a lifetime-buy period is in effect.

NRND: Not recommended for new designs. Device is in production to support existing customers, but TI does not recommend using this part in a new design.

PREVIEW: Device has been announced but is not in production. Samples may or may not be available.

OBSOLETE: TI has discontinued the production of the device.

⁽²⁾ Eco Plan - The planned eco-friendly classification: Pb-Free (RoHS), Pb-Free (RoHS Exempt), or Green (RoHS & no Sb/Br) - please check <http://www.ti.com/productcontent> for the latest availability information and additional product content details.

TBD: The Pb-Free/Green conversion plan has not been defined.

Pb-Free (RoHS): TI's terms "Lead-Free" or "Pb-Free" mean semiconductor products that are compatible with the current RoHS requirements for all 6 substances, including the requirement that lead not exceed 0.1% by weight in homogeneous materials. Where designed to be soldered at high temperatures, TI Pb-Free products are suitable for use in specified lead-free processes.

Pb-Free (RoHS Exempt): This component has a RoHS exemption for either 1) lead-based flip-chip solder bumps used between the die and package, or 2) lead-based die adhesive used between the die and leadframe. The component is otherwise considered Pb-Free (RoHS compatible) as defined above.

Green (RoHS & no Sb/Br): TI defines "Green" to mean Pb-Free (RoHS compatible), and free of Bromine (Br) and Antimony (Sb) based flame retardants (Br or Sb do not exceed 0.1% by weight in homogeneous material)

⁽³⁾ MSL, Peak Temp. -- The Moisture Sensitivity Level rating according to the JEDEC industry standard classifications, and peak solder temperature.

Important Information and Disclaimer:The information provided on this page represents TI's knowledge and belief as of the date that it is provided. TI bases its knowledge and belief on information provided by third parties, and makes no representation or warranty as to the accuracy of such information. Efforts are underway to better integrate information from third parties. TI has taken and continues to take reasonable steps to provide representative and accurate information but may not have conducted destructive testing or chemical analysis on incoming materials and chemicals. TI and TI suppliers consider certain information to be proprietary, and thus CAS numbers and other limited information may not be available for release.

In no event shall TI's liability arising out of such information exceed the total purchase price of the TI part(s) at issue in this document sold by TI to Customer on an annual basis.

TAPE AND REEL INFORMATION

QUADRANT ASSIGNMENTS FOR PIN 1 ORIENTATION IN TAPE

*All dimensions are nominal

Device	Package Type	Package Drawing	Pins	SPQ	Reel Diameter (mm)	Reel Width W1 (mm)	A0 (mm)	B0 (mm)	K0 (mm)	P1 (mm)	W (mm)	Pin1 Quadrant
CDCU2A877ZQLR	BGA MICROSTAR JUNIOR	ZQL	52	1000	330.0	16.4	4.8	7.3	1.5	8.0	16.0	Q1
CDCU2A877ZQLT	BGA MICROSTAR JUNIOR	ZQL	52	250	330.0	16.4	4.8	7.3	1.5	8.0	16.0	Q1

TAPE AND REEL BOX DIMENSIONS



*All dimensions are nominal

Device	Package Type	Package Drawing	Pins	SPQ	Length (mm)	Width (mm)	Height (mm)
CDCU2A877ZQLR	BGA MICROSTAR JUNIOR	ZQL	52	1000	333.2	345.9	28.6
CDCU2A877ZQLT	BGA MICROSTAR JUNIOR	ZQL	52	250	333.2	345.9	28.6

ZQL (R-PBGA-N52)

PLASTIC BALL GRID ARRAY

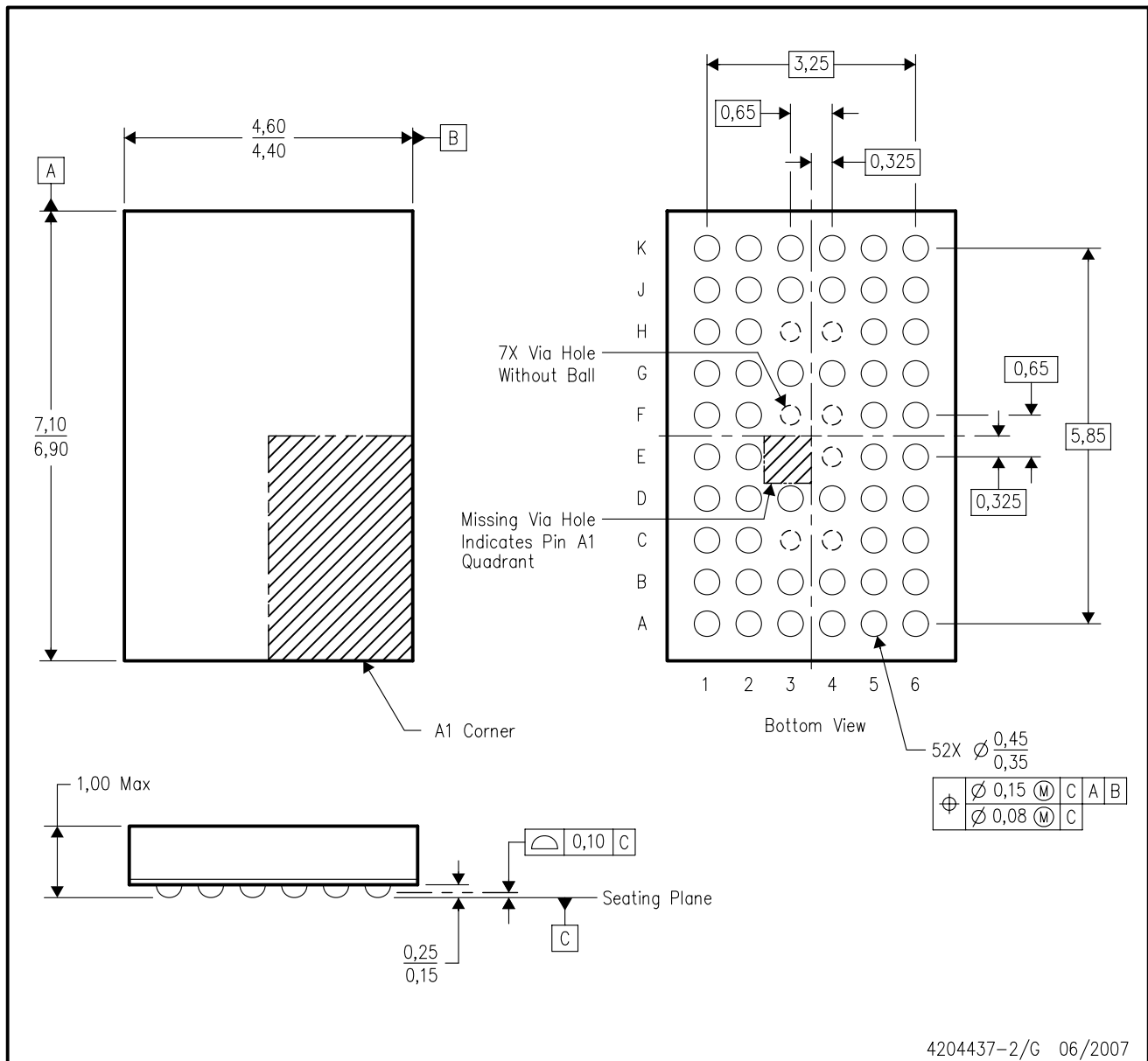

- NOTES:
- A. All linear dimensions are in millimeters. Dimensioning and tolerancing per ASME Y14.5M-1994.
 - B. This drawing is subject to change without notice.
 - C. Falls within JEDEC MO-285 variation BA-2.
 - D. This package is lead-free. Refer to the 52 GQL package (drawing 4200583) for tin-lead (SnPb).

IMPORTANT NOTICE

Texas Instruments Incorporated and its subsidiaries (TI) reserve the right to make corrections, modifications, enhancements, improvements, and other changes to its products and services at any time and to discontinue any product or service without notice. Customers should obtain the latest relevant information before placing orders and should verify that such information is current and complete. All products are sold subject to TI's terms and conditions of sale supplied at the time of order acknowledgment.

TI warrants performance of its hardware products to the specifications applicable at the time of sale in accordance with TI's standard warranty. Testing and other quality control techniques are used to the extent TI deems necessary to support this warranty. Except where mandated by government requirements, testing of all parameters of each product is not necessarily performed.

TI assumes no liability for applications assistance or customer product design. Customers are responsible for their products and applications using TI components. To minimize the risks associated with customer products and applications, customers should provide adequate design and operating safeguards.

TI does not warrant or represent that any license, either express or implied, is granted under any TI patent right, copyright, mask work right, or other TI intellectual property right relating to any combination, machine, or process in which TI products or services are used. Information published by TI regarding third-party products or services does not constitute a license from TI to use such products or services or a warranty or endorsement thereof. Use of such information may require a license from a third party under the patents or other intellectual property of the third party, or a license from TI under the patents or other intellectual property of TI.

Reproduction of TI information in TI data books or data sheets is permissible only if reproduction is without alteration and is accompanied by all associated warranties, conditions, limitations, and notices. Reproduction of this information with alteration is an unfair and deceptive business practice. TI is not responsible or liable for such altered documentation. Information of third parties may be subject to additional restrictions.

Resale of TI products or services with statements different from or beyond the parameters stated by TI for that product or service voids all express and any implied warranties for the associated TI product or service and is an unfair and deceptive business practice. TI is not responsible or liable for any such statements.

TI products are not authorized for use in safety-critical applications (such as life support) where a failure of the TI product would reasonably be expected to cause severe personal injury or death, unless officers of the parties have executed an agreement specifically governing such use. Buyers represent that they have all necessary expertise in the safety and regulatory ramifications of their applications, and acknowledge and agree that they are solely responsible for all legal, regulatory and safety-related requirements concerning their products and any use of TI products in such safety-critical applications, notwithstanding any applications-related information or support that may be provided by TI. Further, Buyers must fully indemnify TI and its representatives against any damages arising out of the use of TI products in such safety-critical applications.

TI products are neither designed nor intended for use in military/aerospace applications or environments unless the TI products are specifically designated by TI as military-grade or "enhanced plastic." Only products designated by TI as military-grade meet military specifications. Buyers acknowledge and agree that any such use of TI products which TI has not designated as military-grade is solely at the Buyer's risk, and that they are solely responsible for compliance with all legal and regulatory requirements in connection with such use.

TI products are neither designed nor intended for use in automotive applications or environments unless the specific TI products are designated by TI as compliant with ISO/TS 16949 requirements. Buyers acknowledge and agree that, if they use any non-designated products in automotive applications, TI will not be responsible for any failure to meet such requirements.

Following are URLs where you can obtain information on other Texas Instruments products and application solutions:

Products

Amplifiers	amplifier.ti.com
Data Converters	dataconverter.ti.com
DLP® Products	www.dlp.com
DSP	dsp.ti.com
Clocks and Timers	www.ti.com/clocks
Interface	interface.ti.com
Logic	logic.ti.com
Power Mgmt	power.ti.com
Microcontrollers	microcontroller.ti.com
RFID	www.ti-rfid.com
RF/IF and ZigBee® Solutions	www.ti.com/lprf

Applications

Audio	www.ti.com/audio
Automotive	www.ti.com/automotive
Broadband	www.ti.com/broadband
Digital Control	www.ti.com/digitalcontrol
Medical	www.ti.com/medical
Military	www.ti.com/military
Optical Networking	www.ti.com/opticalnetwork
Security	www.ti.com/security
Telephony	www.ti.com/telephony
Video & Imaging	www.ti.com/video
Wireless	www.ti.com/wireless

Mailing Address: Texas Instruments, Post Office Box 655303, Dallas, Texas 75265
Copyright © 2009, Texas Instruments Incorporated

Looking for pricing, stock, or lifecycle information?

Click below to explore more details on WIN SOURCE:

 [View CDCU2A877ZQLR](#) on WIN SOURCE

 [Texas Instruments](#) Information

Optimize Your Supply Chain with WIN SOURCE Solutions

-  Global Sourcing Solution
-  Obsolete Management
-  Cost Control Management
-  Shortage Management
-  Alternative Solution
-  Excess Inventory Management