



**THE DATASHEET OF
CDCS503PWR**



Clock Buffer/Clock Multiplier With Optional SSC

FEATURES

- Part of a Family of Easy to use Clock Generator Devices With Optional SSC
- Clock Multiplier With Selectable Output Frequency and Selectable SSC
- SSC Controllable via 2 External Pins
 - $\pm 0\%$, $\pm 0.5\%$, $\pm 1\%$, $\pm 2\%$ Center Spread
- Frequency Multiplication Selectable Between x1 or x4 With One External Control Pin
- Output Disable via Control Pin
- Single 3.3V Device Power Supply
- Wide Temperature Range -40°C to 85°C
- Low Space Consumption by 8 Pin TSSOP Package

APPLICATIONS

- Consumer and Industrial Applications requiring EMI reduction through Spread Spectrum Clocking and/ or Clock Multiplication

PACKAGE



BLOCK DIAGRAM

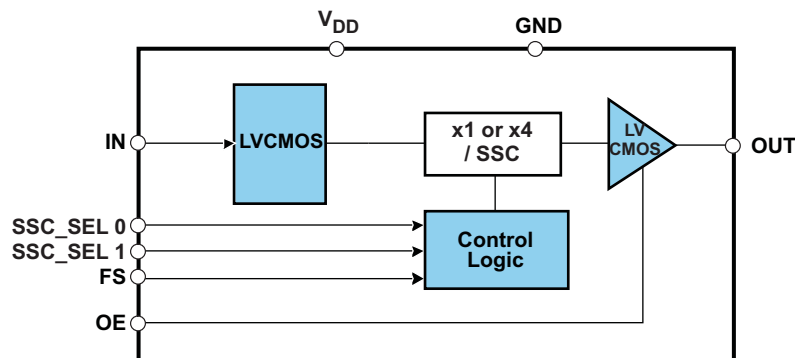

DESCRIPTION

The CDCS503 is a spread spectrum capable, LVC MOS Input Clock Buffer with selectable frequency multiplication.

It shares major functionality with the CDCS502 but utilizes a LVC MOS input stage instead of the crystal input stage of the CDCS502. Also an Output Enable pin has been added to the CDCS503.

The device accepts a 3.3V LVC MOS signal at the input.

The input signal is processed by a PLL, whose output frequency is either equal to the input frequency or multiplied by the factor of 4.

The PLL is also able to spread the clock signal by $\pm 0\%$, $\pm 0.5\%$, $\pm 1\%$ or $\pm 2\%$ centered around the output clock frequency with a triangular modulation.

By this, the device can generate output frequencies between 8MHz and 108MHz with or without SSC.

A separate control pin can be used to enable or disable the output. The CDCS503 operates in 3.3V environment.

It is characterized for operation from -40°C to 85°C , and available in an 8-pin TSSOP package.



Please be aware that an important notice concerning availability, standard warranty, and use in critical applications of Texas Instruments semiconductor products and disclaimers thereto appears at the end of this data sheet.

FUNCTION TABLE

OE	FS	SSC_SEL 0	SSC_SEL 1	SSC AMOUNT	f_{OUT}/f_{IN}	f_{OUT} at $f_{in} = 27$ MHz
0	x	x	x	x	x	3-state
1	0	0	0	±0.00%	1	27 MHz
1	0	0	1	±0.50%	1	27 MHz
1	0	1	0	±1.00%	1	27 MHz
1	0	1	1	±2.00%	1	27 MHz
1	1	0	0	±0.00%	4	108 MHz
1	1	0	1	±0.50%	4	108 MHz
1	1	1	0	±1.00%	4	108 MHz
1	1	1	1	±2.00%	4	108 MHz

DEVICE INFORMATION

PACKAGE

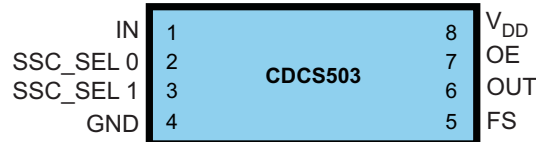

PIN FUNCTIONS

SIGNAL	PIN	TYPE	DESCRIPTION
IN	1	I	LVC MOS Clock input
OUT	6	O	LVC MOS Clock Output
SSC_SEL 0, 1	2, 3	I	Spread Selection Pins, internal pull-up
OE	7	I	Output Enable, internal pull-up
FS	5	I	Frequency Multiplication Selection, internal pull-up
V_{DD}	8	Power	3.3V Power Supply
GND	4	Ground	Ground

PACKAGE THERMAL RESISTANCE FOR TSSOP (PW) PACKAGE

over operating free-air temperature range (unless otherwise noted)⁽¹⁾

CDCS503PW 8-PIN TSSOP		THERMAL AIRFLOW (CFM)				UNIT
		0	150	250	500	
$R_{\theta JA}$	High K	149	142	138	132	°C/W
	Low K	230	185	170	150	
$R_{\theta JC}$	High K	65				°C/W
	Low K	69				

(1) The package thermal impedance is calculated in accordance with JESD 51 and JEDEC2S2P (high-k board).

ABSOLUTE MAXIMUM RATINGS

over operating free-air temperature range (unless otherwise noted)

		VALUE	UNIT
V_{DD}	Supply voltage range	–0.5 to 4.6	V
V_{IN}	Input voltage range ⁽¹⁾	–0.5 to 4.6	V
V_{out}	Output voltage range ⁽¹⁾	–0.5 to 4.6	V
I_{IN}	Input current ($V_I < 0$, $V_I > V_{DD}$)	20	mA
I_{out}	Continuous output current	50	mA
T_{ST}	Storage temperature range	–65 to 150	°C
T_J	Maximum junction temperature	125	°C

(1) Stresses beyond those listed under *absolute maximum ratings* may cause permanent damage to the device. These are stress ratings only and functional operation of the device at these or any other conditions beyond those indicated under *recommended operating conditions* is not implied. Exposure to absolute-maximum-rated conditions for extended periods may affect device reliability.

RECOMMENDED OPERATING CONDITIONS

		MIN	NOM	MAX	UNIT
V_{DD}	Supply voltage	3.0		3.6	V
f_{IN}	Input frequency	FS = 0	8	32	MHz
		FS = 1	8	27	
V_{IL}	Low level input voltage LVCMOS			$0.3 V_{DD}$	V
V_{IH}	High level input voltage LVCMOS	$0.7 V_{DD}$			V
V_I	Input voltage threshold LVCMOS		$0.5 V_{DD}$		V
C_L	Output load test LVCMOS			15	pF
I_{OH}/I_{OL}	Output current			±12	mA
T_A	Operating free-air temperature	–40		85	°C

DEVICE CHARACTERISTICS

over recommended operating free-air temperature range (unless otherwise noted)

PARAMETER	TEST CONDITIONS	MIN	TYP	MAX	UNIT
IDD	Device supply current	$f_{out} = 20$ MHz; FS = 0, no SSC			mA
		$f_{out} = 70$ MHz; FS = 1, SSC = 2%			
f_{OUT}	Output frequency	FS = 0			MHz
		FS = 1			
I_{IH}	LVCMOS input current	$V_I = V_{DD}$; $V_{DD} = 3.6$ V			μA
I_{IL}	LVCMOS input current	$V_I = 0$ V; $V_{DD} = 3.6$ V			μA
V_{OH}	LVCMOS high-level output voltage	$I_{OH} = -0.1$ mA			V
		$I_{OH} = -8$ mA			
		$I_{OH} = -12$ mA			
V_{OL}	LVCMOS low-level output voltage	$I_{OL} = 0.1$ mA			V
		$I_{OL} = 8$ mA			
		$I_{OL} = 12$ mA			
I_{OZ}	High-impedance-state output current	OE = Low			μA
$t_{JIT(C-C)}$	Cycle to cycle jitter ⁽¹⁾	$f_{out} = 108$ MHz; FS = 1, SSC = 1%, 10000 Cycles			ps
t_r/t_f	Rise and fall time ⁽¹⁾	20%–80%			ns
O_{dc}	Output duty cycle	45%			55%
f_{MOD}	Modulation frequency	30			kHz

(1) Measured with Test Load, see [Figure 2](#).

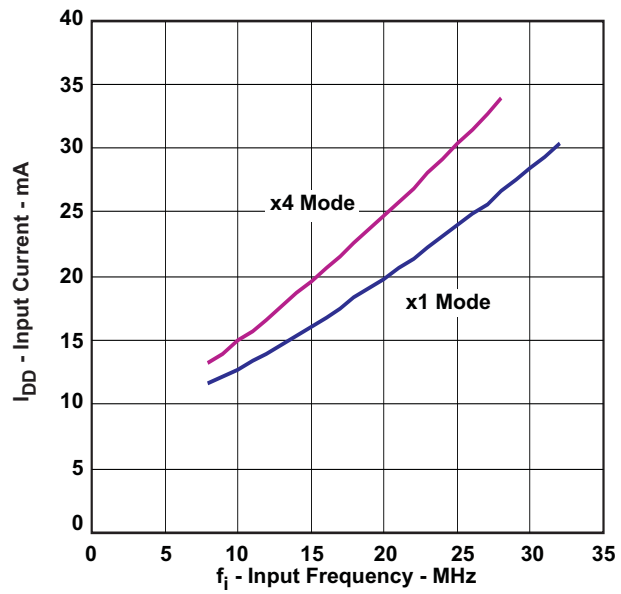

Figure 1. IDD vs Input Frequency, VCC = 3.3V, SSC = 2%, Output Loaded With Test Load

APPLICATION INFORMATION

SSC MODULATION

The exact implementation of the SSC modulation plays a vital role for the EMI reduction. The CDCS503 uses a triangular modulation scheme implemented in a way that the modulation frequency depends on the VCO frequency of the internal PLL and the spread amount is independent from the VCO frequency.

The modulation frequency can be calculated by using one of the below formulas chosen by frequency multiplication mode.

$$FS = 0: f_{\text{mod}} = f_{\text{IN}} / 708$$

$$FS = 1: f_{\text{mod}} = f_{\text{IN}} / 620$$

PARAMETER MEASUREMENT INFORMATION

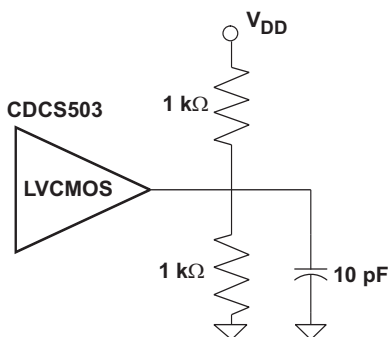

Figure 2. Test Load

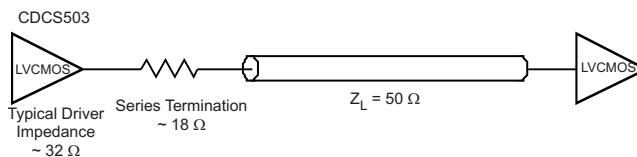

Figure 3. Load for 50-Ω Board Environment

TAPE AND REEL INFORMATION



QUADRANT ASSIGNMENTS FOR PIN 1 ORIENTATION IN TAPE



*All dimensions are nominal

Device	Package Type	Package Drawing	Pins	SPQ	Reel Diameter (mm)	Reel Width W1 (mm)	A0 (mm)	B0 (mm)	K0 (mm)	P1 (mm)	W (mm)	Pin1 Quadrant
CDCS503PWR	TSSOP	PW	8	2000	330.0	12.4	7.0	3.6	1.6	8.0	12.0	Q1

TAPE AND REEL BOX DIMENSIONS



*All dimensions are nominal

Device	Package Type	Package Drawing	Pins	SPQ	Length (mm)	Width (mm)	Height (mm)
CDCS503PWR	TSSOP	PW	8	2000	367.0	367.0	35.0

PW0008A



PACKAGE OUTLINE

TSSOP - 1.2 mm max height

SMALL OUTLINE PACKAGE

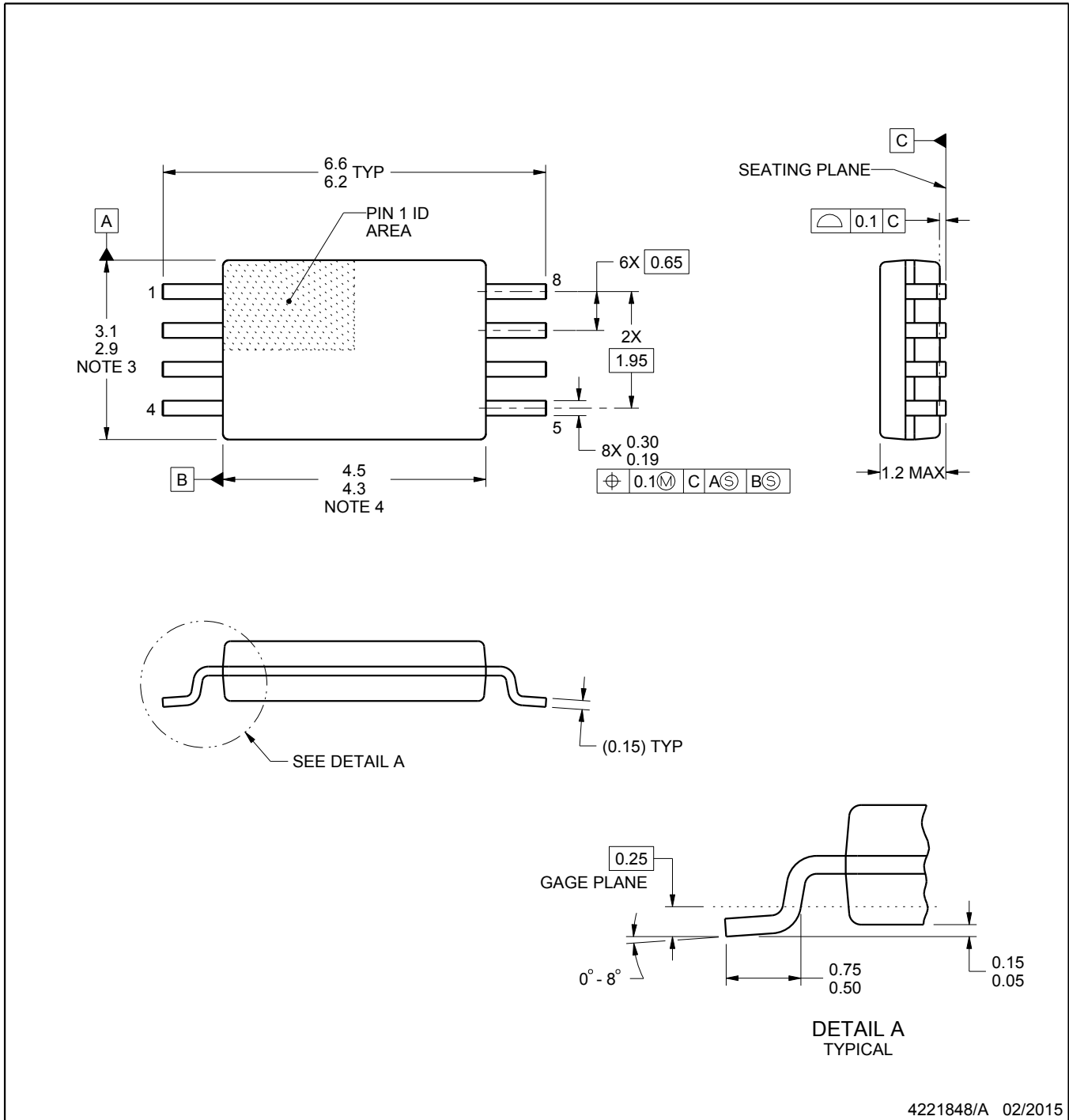

4221848/A 02/2015

NOTES:

1. All linear dimensions are in millimeters. Any dimensions in parenthesis are for reference only. Dimensioning and tolerancing per ASME Y14.5M.
2. This drawing is subject to change without notice.
3. This dimension does not include mold flash, protrusions, or gate burrs. Mold flash, protrusions, or gate burrs shall not exceed 0.15 mm per side.
4. This dimension does not include interlead flash. Interlead flash shall not exceed 0.25 mm per side.
5. Reference JEDEC registration MO-153, variation AA.

EXAMPLE BOARD LAYOUT

PW0008A

TSSOP - 1.2 mm max height

SMALL OUTLINE PACKAGE

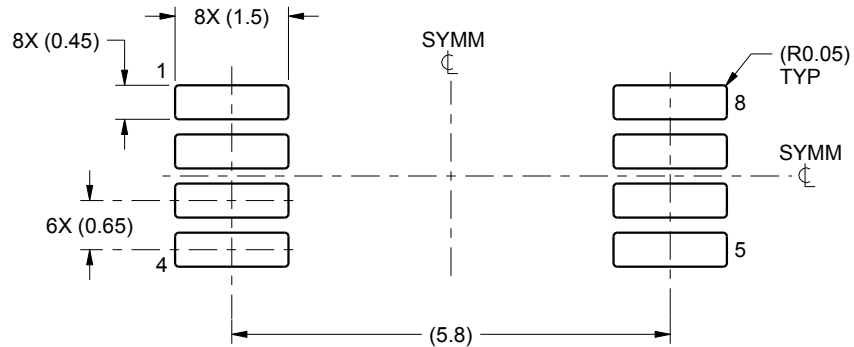

LAND PATTERN EXAMPLE
SCALE:10X

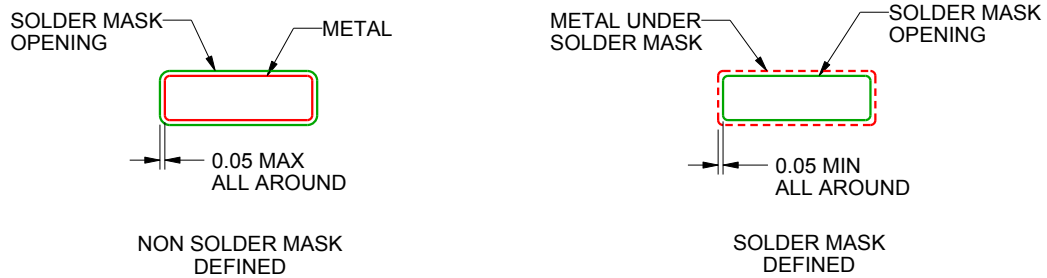

SOLDER MASK DETAILS
NOT TO SCALE

4221848/A 02/2015

NOTES: (continued)

- 6. Publication IPC-7351 may have alternate designs.
- 7. Solder mask tolerances between and around signal pads can vary based on board fabrication site.

EXAMPLE STENCIL DESIGN

PW0008A

TSSOP - 1.2 mm max height

SMALL OUTLINE PACKAGE

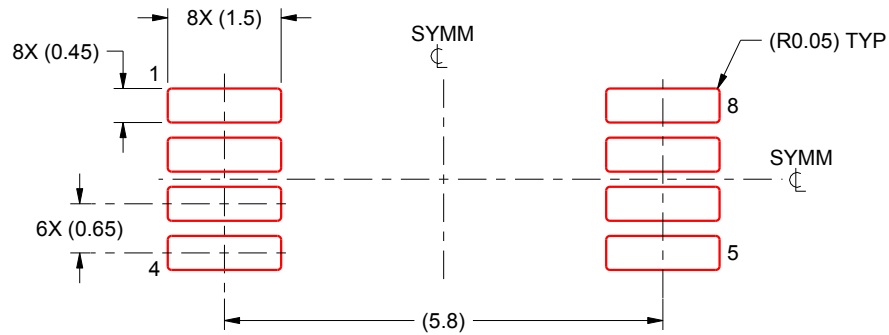

SOLDER PASTE EXAMPLE
BASED ON 0.125 mm THICK STENCIL
SCALE:10X

4221848/A 02/2015

NOTES: (continued)

8. Laser cutting apertures with trapezoidal walls and rounded corners may offer better paste release. IPC-7525 may have alternate design recommendations.
9. Board assembly site may have different recommendations for stencil design.

IMPORTANT NOTICE AND DISCLAIMER

TI PROVIDES TECHNICAL AND RELIABILITY DATA (INCLUDING DATASHEETS), DESIGN RESOURCES (INCLUDING REFERENCE DESIGNS), APPLICATION OR OTHER DESIGN ADVICE, WEB TOOLS, SAFETY INFORMATION, AND OTHER RESOURCES "AS IS" AND WITH ALL FAULTS, AND DISCLAIMS ALL WARRANTIES, EXPRESS AND IMPLIED, INCLUDING WITHOUT LIMITATION ANY IMPLIED WARRANTIES OF MERCHANTABILITY, FITNESS FOR A PARTICULAR PURPOSE OR NON-INFRINGEMENT OF THIRD PARTY INTELLECTUAL PROPERTY RIGHTS.

These resources are intended for skilled developers designing with TI products. You are solely responsible for (1) selecting the appropriate TI products for your application, (2) designing, validating and testing your application, and (3) ensuring your application meets applicable standards, and any other safety, security, or other requirements. These resources are subject to change without notice. TI grants you permission to use these resources only for development of an application that uses the TI products described in the resource. Other reproduction and display of these resources is prohibited. No license is granted to any other TI intellectual property right or to any third party intellectual property right. TI disclaims responsibility for, and you will fully indemnify TI and its representatives against, any claims, damages, costs, losses, and liabilities arising out of your use of these resources.

TI's products are provided subject to TI's Terms of Sale (www.ti.com/legal/termsofsale.html) or other applicable terms available either on ti.com or provided in conjunction with such TI products. TI's provision of these resources does not expand or otherwise alter TI's applicable warranties or warranty disclaimers for TI products.

Mailing Address: Texas Instruments, Post Office Box 655303, Dallas, Texas 75265
Copyright © 2018, Texas Instruments Incorporated

Looking for pricing, stock, or lifecycle information?

Click below to explore more details on WIN SOURCE:

- ⊖ [View CDCS503PWR](#) on WIN SOURCE
- ⊖ [Texas Instruments](#) Information

Optimize Your Supply Chain with WIN SOURCE Solutions

- ✓ Global Sourcing Solution
- ✓ Obsolete Management
- ✓ Cost Control Management
- ✓ Shortage Management
- ✓ Alternative Solution
- ✓ Excess Inventory Management