



THE DATASHEET OF CDCR81DBQR



CDCR81 DIRECT RAMBUS™ CLOCK GENERATOR

SCAS606B – NOVEMBER 1998 – REVISED NOVEMBER 1999

- **300-MHz Differential Clock Source for Direct RAMBUS Memory Systems for an 600-MHz Data Transfer Rate**
- **Synchronizes the Clock Domains of the Rambus Channel With an External System or Processor Clock**
- **Three Power Operating Modes to Minimize Power for Mobile and Other Power-Sensitive Applications**
- **Operates From a Single 3.3-V Supply and 120-mW at 300 MHz (Typ)**
- **Packaged in a Shrink Small-Outline Package (DBQ)**
- **Wide Phase-Lock Input Frequency Range 33 MHz to 100 MHz**
- **No External Components Required for PLL**
- **Supports Independent Channel Clocking**
- **Spread Spectrum Clocking Tracking Capability to Reduce EMI**
- **Designed For Use With TI's 133-MHz Clock Synthesizers CDC925, CDC924, CDC922 and CDC921**

**DBQ PACKAGE
(TOP VIEW)**

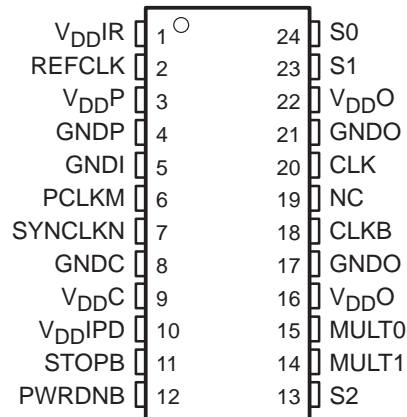

NC – No internal connection

description

The Direct Rambus clock generator (DRCG) provides the necessary clock signals to support a Direct Rambus memory subsystem. It includes signals to synchronize the Direct Rambus channel clock to an external system or processor clock. It is designed to support Direct Rambus memory on desktop, workstation, server and mobile PC motherboards. DRCG also provides an off-the-shelf solution for a broad range of Direct Rambus memory applications.

The DRCG provides clock multiplication and phase alignment for a Direct Rambus memory subsystem to enable synchronous communication between the Rambus channel and ASIC clock domains. In a Direct Rambus memory subsystem, a system clock source provides the REFCLK and PCLK clock references to the DRCG and memory controller, respectively. The DRCG multiplies REFCLK and drives a high-speed BUSCLK to RDRAMs and the memory controller. Gear ratio logic in the memory controller divides the PCLK and BUSCLK frequencies by ratios M and N such that $PCLK/M = SYNCLK/N$, where $SYNCLK = BUSCLK/4$. The DRCG detects the phase difference between PCLK/M and SYNCLK/N and adjusts the phase of BUSCLK such that the skew between PCLK/M and SYNCLK/N is minimized. This allows data to be transferred across the SYNCLK/PCLK boundary without incurring additional latency.

User control is provided by multiply and mode selection terminals. The multiply terminals provide selection of one of four clock frequency multiply ratios, generating BUSCLK frequencies ranging from 267 MHz to 400 MHz with clock references ranging from 33 MHz to 100 MHz. The CDCR81 meets Rambus Clock Generator, Revision 1.0 specification up to 300 MHz. The mode select terminals can be used to select a bypass mode where the frequency multiplied reference clock is directly output to the Rambus channel for systems where synchronization between the Rambus clock and a system clock is not required. Test modes are provided to bypass the PLL and output REFCLK on the Rambus channel and to place the outputs in a high-impedance state for board testing.



Please be aware that an important notice concerning availability, standard warranty, and use in critical applications of Texas Instruments semiconductor products and disclaimers thereto appears at the end of this data sheet.

Direct Rambus and Rambus are trademarks of Rambus Inc.

PRODUCTION DATA information is current as of publication date. Products conform to specifications per the terms of Texas Instruments standard warranty. Production processing does not necessarily include testing of all parameters.

 **TEXAS
INSTRUMENTS**

POST OFFICE BOX 655303 • DALLAS, TEXAS 75265

Copyright © 1999, Texas Instruments Incorporated

CDCR81 DIRECT RAMBUS™ CLOCK GENERATOR

SCAS606B – NOVEMBER 1998 – REVISED NOVEMBER 1999

description (continued)

The CDCR81 is characterized for operation over free-air temperatures of 0°C to 85°C.

functional block diagram

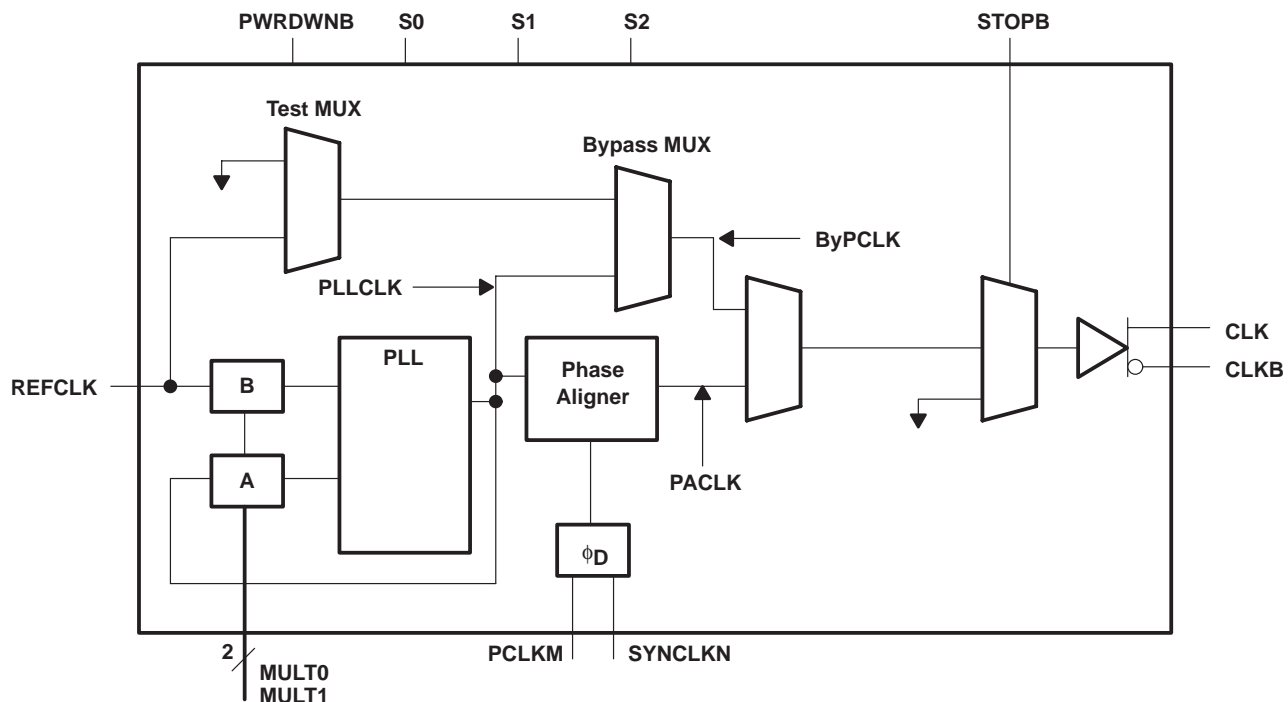

FUNCTION TABLE†

MODE	S0	S1	S2	CLK	CLKB
Normal	0	0	0	Phase aligned clock	Phase aligned clock B
Bypass	1	0	0	PLLCLK	PLLCLKB
Test	1	1	0	REFCLK	REFCLKB
Output test (OE)	0	1	X	Hi-Z	Hi-Z
Reserved	0	0	1	—	—
Reserved	1	0	1	—	—
Reserved	1	1	1	Hi-Z	Hi-Z

† X = don't care, Hi-Z = high impedance

CDCR81 DIRECT RAMBUS™ CLOCK GENERATOR

SCAS606B – NOVEMBER 1998 – REVISED NOVEMBER 1999

Terminal Functions

TERMINAL NAME	NO.	I/O	DESCRIPTION
CLK	20	O	Output clock
CLKB	18	O	Output clock (complement)
GNDC	8		GND for phase aligner
GNDI	5		GND for control inputs
GNDO	17, 21		GND for clock outputs
GNDP	4		GND for PLL
MULT0	15	I	PLL multiplier select
MULT1	14	I	PLL multiplier select
NC	19		Not used
PCLKM	6	I	Phase detector input
PWRDNB	12	I	Active low power down
REFCLK	2	I	Reference clock
S0	24	I	Mode control
S1	23	I	Mode control
S2	13	I	Mode control
STOPB	11	I	Active low output disable
SYNCLKN	7	I	Phase detector input
V _{DDC}	9		V _{DD} for phase aligner
V _{DDIPD}	10		Reference voltage for phase detector inputs and STOPB
V _{DDIR}	1		Reference voltage for REFCLK
V _{DDO}	16, 22		V _{DD} for clock outputs
V _{DDP}	3		V _{DD} for PLL



CDCR81 DIRECT RAMBUS™ CLOCK GENERATOR

SCAS606B – NOVEMBER 1998 – REVISED NOVEMBER 1999

PLL divider selection

Table 1 lists the supported REFCLK and BUSCLK frequencies. Other REFCLK frequencies are permitted, provided that (267 MHz < BUSCLK < 400 MHz) and (33 MHz < REFCLK < 100 MHz).

Table 1. REFCLK and BUSCLK Frequencies

MULT0	MULT1	REFCLK (MHz)	MULTIPLY RATIO	BUSCLK (MHz)
0	0	67	4	267
0	1	50	6	300
0	1	67	6	400
1	1	33	8	267
1	1	50	8	400
1	0	100	8/3	267

clock output driver states

Table 2. Clock Output Driver States

STATE	PWRDNB	STOPB	CLK	CLKB
Powerdown	0	X	GND	GND
CLK stop	1	0	V _X , STOP	V _X , STOP
Normal	1	1	PACLK/PLLCLK/ REFCLK†	PACLKB/PLLCLKB/ REFCLKB

† Depending on the state of S0, S1, and S2.

absolute maximum ratings over operating free-air temperature (unless otherwise noted)†

Supply voltage range, V _{DD} (see Note 1)	−0.5 V to 4 V
Output voltage range, V _O , at any output terminal	−0.5 V to V _{DD} + 0.5 V
Input voltage range, V _I , at any input terminal	−0.5 V to V _{DD} + 0.5 V
ESD rating	TBD
Continuous total power dissipation	see Dissipation Rating Table
Operating free-air temperature range, T _A	0°C to 85°C
Storage temperature range, T _{stg}	−65°C to 150°C
Lead temperature 1,6 mm (1/16 inch) from case for 10 seconds	260°C

† Stresses beyond those listed under “absolute maximum ratings” may cause permanent damage to the device. These are stress ratings only, and functional operation of the device at these or any other conditions beyond those indicated under “recommended operating conditions” is not implied. Exposure to absolute-maximum-rated conditions for extended periods may affect device reliability.

NOTE 1: All voltage values are with respect to the GND terminals.

DISSIPATION RATING TABLE

PACKAGE	T _A ≤ 25°C POWER RATING	DERATING FACTOR ABOVE T _A = 25°C‡	T _A = 70°C POWER RATING	T _A = 85°C POWER RATING
DBQ	1400 mW	11 mW/°C	905 mW	740 mW

‡ This is the inverse of the junction-to-ambient thermal resistance when board-mounted and with no air flow.



CDCR81 DIRECT RAMBUS™ CLOCK GENERATOR

SCAS606B – NOVEMBER 1998 – REVISED NOVEMBER 1999

recommended operating conditions

	MIN	NOM	MAX	UNIT
Supply voltage, V_{DD}	3.135	3.3	3.465	V
High-level input voltage, V_{IH} (CMOS)	$0.7 \times V_{DD}$			V
Low-level input voltage, V_{IL} (CMOS)	$0.3 \times V_{DD}$			V
Initial phase error at phase detector inputs (required range for phase aligner)	$-0.5 \times t_c(\text{PD})$		$0.5 \times t_c(\text{PD})$	
REFCLK low-level input voltage, V_{IL}	$0.3 \times V_{DDIR}$			V
REFCLK high-level input voltage, V_{IH}	$0.7 \times V_{DDIR}$			V
Input signal low voltage, V_{IL} (STOPB)	$0.3 \times V_{DDIPD}$			V
Input signal high voltage, V_{IH} (STOPB)	$0.7 \times V_{DDIPD}$			V
Input reference voltage for (REFCLK) (V_{DDIR})	1.235		3.465	V
Input reference voltage for (PCLKM and SYNCLKN) (V_{DDIPD})	1.235		3.465	V
High-level output current, I_{OH}				-16 mA
Low-level output current, I_{OL}				16 mA
Operating free-air temperature, T_A	0		85	°C

timing requirements

	MIN	MAX	UNIT
Input cycle time, $t_{c(\text{in})}$	10	40	ns
Input cycle-to-cycle jitter		250	ps
Input duty cycle over 10,000 cycles	40%	60%	
Input frequency modulation, f_{mod}	30	33	kHz
Modulation index, non-linear maximum 0.5%		0.6%	
Phase detector input cycle time (PCLKM and SYNCLKN)	30	100	ns
Input slew rate, SR	1	4	V/ns
Input duty cycle (PCLKM and SYNCLKN)	25%	75%	



CDCR81 DIRECT RAMBUS™ CLOCK GENERATOR

SCAS606B – NOVEMBER 1998 – REVISED NOVEMBER 1999

electrical characteristics over recommended operating free-air temperature range (unless otherwise noted)

PARAMETER		TEST CONDITIONS†	MIN	TYP‡	MAX	UNIT	
V _{O(STOP)}	Output voltage during CLK Stop (StopB=0)	See Figure 1	1.1		2		
V _{O(X)}	Output crossing-point voltage	See Figures 1 and 6	1.3		1.8	V	
V _O	Output voltage swing	See Figure 1	0.4		0.6	V	
V _{IK}	Input clamp voltage	V _{DD} = 3.135 V, I _I = -18 mA			-1.2	V	
V _{OH}	High-level output voltage	See Figure 1			2	V	
		V _{DD} = min to max, I _{OH} = -1 mA	V _{DD} - 0.1 V				
		V _{DD} = 3.135 V, I _{OH} = -16 mA	2.4				
V _{OL}	Low-level output voltage	See Figure 1	1			V	
		V _{DD} = min to max, I _{OL} = 1 mA			0.1		
		V _{DD} = 3.135 V, I _{OL} = 16 mA			0.5		
I _{OH}	High-level output current	V _{DD} = 3.135 V, V _O = 1 V	-32	-52		mA	
		V _{DD} = 3.3 V, V _O = 1.65 V		-51			
		V _{DD} = 3.465 V, V _O = 3.135 V	-14.5	-21			
I _{OL}	Low-level output current	V _{DD} = 3.135 V, V _O = 1.95 V	43	61.5		mA	
		V _{DD} = 3.3 V, V _O = 1.65 V		65			
		V _{DD} = 3.465 V, V _O = 0.4 V		25.5	36		
I _{OZ}	High-impedance-state output current	S ₀ = 0, S ₁ = 1			±10	µA	
I _{OZ(STOP)}	High-impedance-state output current during CLK stop	Stop = 0, V _O = GND or V _{DD}			±100	µA	
I _{OZ(PD)}	High-impedance-state output current in powerdown state	PWDNB = 0, V _O = GND or V _{DD}	-10		100	µA	
I _{IH}	High-level input current	REFCLK, PCLKM, SYNCLKN, STOPB	V _{DD} = 3.465 V, V _I = V _{DD}		10	µA	
		PWRDNB, S ₀ , S ₁ , S ₂ , MULT0, MULT1	V _{DD} = 3.465 V, V _I = V _{DD}		10		
I _{IL}	Low-level input current	REFCLK, PCLKM, SYNCLKN, STOPB	V _{DD} = 3.465 V, V _I = 0		-10	µA	
		PWRDNB, S ₀ , S ₁ , S ₂ , MULT0, MULT1	V _{DD} = 3.465 V, V _I = 0		-10		
Z _O	Output impedance	High state	R _I at I _O -14.5 mA to -16.5 mA	15	26	40	Ω
		Low state	R _I at I _O 14.5 mA to 16.5 mA	11	17	35	
	Reference current	V _{DDIR} , V _{DDIPD}	V _{DD} = 3.465 V,	PWRDNB = 0		50	µA
				PWRDNB = 1		0.5	mA
C _I	Input capacitance	V _I = V _{DD} or GND		1.8		pF	
C _O	Output capacitance	V _O = V _{DD} or GND		3.1		pF	
I _{DD(PD)}	Supply current in powerdown state	REFCLK = 0 MHz to 100 MHz, PWDNB = 0, STOPB = 1			200	µA	
I _{DD(CLKSTOP)}	Supply current in CLK stop state	BUSCLK configured for 400 MHz			30	mA	
I _{DD(NORMAL)}	Supply current in normal state	BUSCLK = 400 MHz			70	mA	

† V_{DD} refers to any of the following; V_{DD}, V_{DDIPD}, V_{DDIR}, V_{DDO}, V_{DDC}, and V_{DDP}

‡ All typical values are at V_{DD} = 3.3 V, T_A = 25°C.



switching characteristics over recommended operating free-air temperature range (unless otherwise noted)

PARAMETER			TEST CONDITIONS	MIN	TYP†	MAX	UNIT
$t_{c(out)}$	Clock output cycle time			2.5		3.75	ns
$t_{(jitter)}$	Total cycle jitter over 1, 2, 3, 4, 5, or 6 clock cycles	Stopped phase alignment	267 MHz – 400 MHz	See Figure 3		60	ps
		Infinite phase alignment	267 MHz	See Figure 3		80	ps
			300 MHz			70	
$t_{(phase)}$	Phase detector phase error for distributed loop		Static phase error	-50		50	ps
$t_{(phase, SSC)}$	PLL output phase error when tracking SSC		Dynamic phase error	-100		100	ps
$t_{(DC)}$	Output duty cycle over 10,000 cycles		See Figure 4	45%		55%	
$t_{(DC, err)}$	Output cycle-to-cycle duty cycle error	Stopped phase alignment	267 MHz – 400 MHz	See Figure 5		50	ps
			267 MHz	See Figure 5		70	ps
		Infinite phase alignment	300 MHz			80	
			400 MHz	90			
t_r, t_f	Output rise and fall times (measured at 20%-80% of output voltage)		See Figure 7	200		450	ps
Δt	Difference between rise and fall times on a single device (20%–80%) $ t_f - t_r $		See Figure 7			100	ps

† All typical values are at $V_{DD} = 3.3\text{ V}$, $T_A = 25^\circ\text{C}$.

state transition latency specifications

PARAMETER		FROM	TO	TEST CONDITIONS	MIN	TYP†	MAX	UNIT
$t_{(powerup)}$	Delay time, PWRDNB↑ to CLK/CLKB output settled (excluding $t_{(DISTLOCK)}$)	Power-down	Normal	See Figure 8			3	ms
	Delay time, PWRDNB↑ to internal PLL and clock are on and settled						3	
$t_{(VDDpowerup)}$	Delay time, powerup to CLK/CLKB output settled	V_{DD}	Normal	See Figure 8			3	ms
	Delay time, powerup to internal PLL and clock are on and settled						3	
$t_{(MULT)}$	MULT0 and MULT1 change to CLK/CLKB output resettled (excluding $t_{(DISTLOCK)}$)	Normal	Normal	See Figure 9			1	ms
$t_{(CLKON)}$	STOPB↑ to CLK/CLKB glitch-free clock edges	CLK Stop	Normal	See Figure 10			10	ns
$t_{(CLKSETL)}$	STOPB↑ to CLK/CLKB output settled to within 50 ps of the phase before STOPB was disabled	CLK Stop	Normal	See Figure 10			20	cycles
$t_{(CLKOFF)}$	STOPB↑ to CLK/CLKB output disabled	Normal	CLK Stop	See Figure 10			5	ns
$t_{(powerdown)}$	Delay time, PWRDNB↓ to the device in power-down mode	STOPB	Power-down				1	ms
$t_{(STOP)}$	Maximum time in CLKSTOP (STOPB = 0) before re-entering normal mode (STOPB = 1)	STOPB	Normal				100	μs

CDCR81 DIRECT RAMBUS™ CLOCK GENERATOR

SCAS606B – NOVEMBER 1998 – REVISED NOVEMBER 1999

state transition latency specifications (continued)

PARAMETER	FROM	TO	TEST CONDITIONS	MIN	TYP†	MAX	UNIT
$t_{(ON)}$	Normal	CLK stop		100			ms
$t_{(DISTLOCK)}$	Un-locked	Locked				5	ms

PARAMETER MEASUREMENT INFORMATION

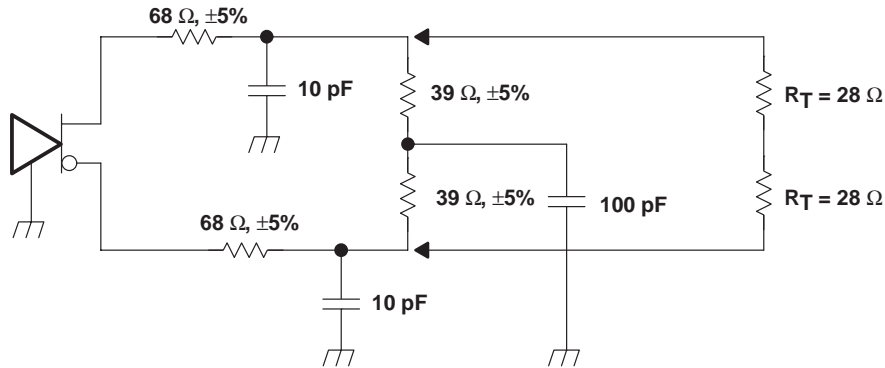
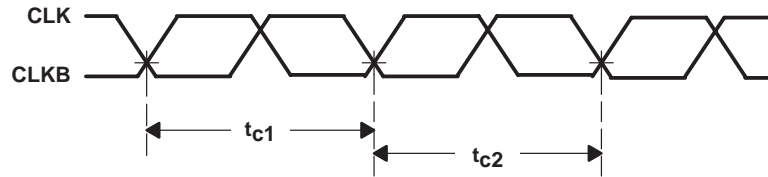
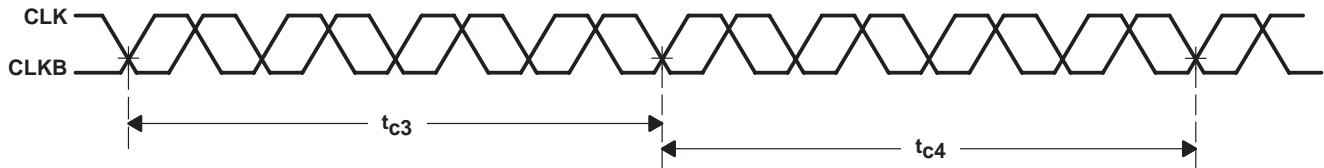

Figure 1. Test Load and Voltage Definitions ($V_{O(STOP)}$, $V_{O(X)}$, V_O , V_{OH} , V_{OL})



Cycle-to-cycle jitter = $|t_{c1} - t_{c2}|$ over 10000 consecutive cycles

Figure 2. Cycle-to-Cycle Jitter



Cycle-to-cycle jitter = $|t_{c3} - t_{c4}|$ over 10000 consecutive cycles

Figure 3. Short Term Cycle-to-Cycle Jitter over 4 Cycles

PARAMETER MEASUREMENT INFORMATION

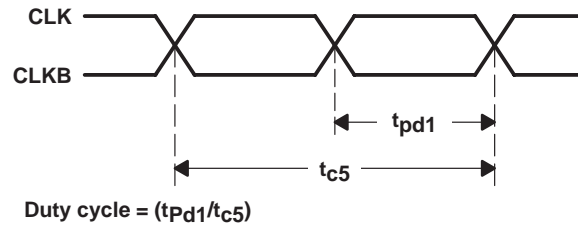

Figure 4. Output Duty Cycle

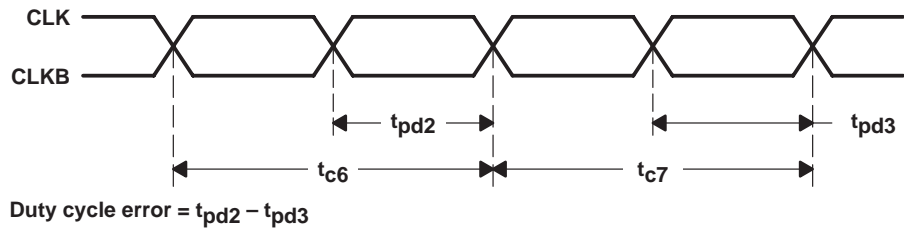

Figure 5. Duty Cycle Error (Cycle-to-Cycle)

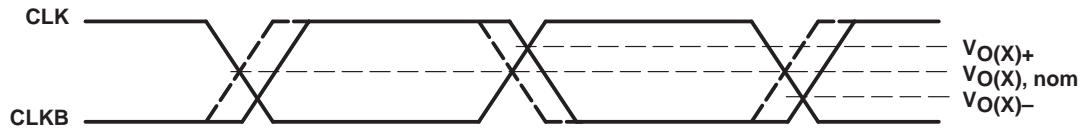

Figure 6. Crossing-Point Voltage



Figure 7. Voltage Waveforms



Figure 8. PWRDNB Transition Timings

CDCR81 DIRECT RAMBUS™ CLOCK GENERATOR

SCAS606B – NOVEMBER 1998 – REVISED NOVEMBER 1999

PARAMETER MEASUREMENT INFORMATION

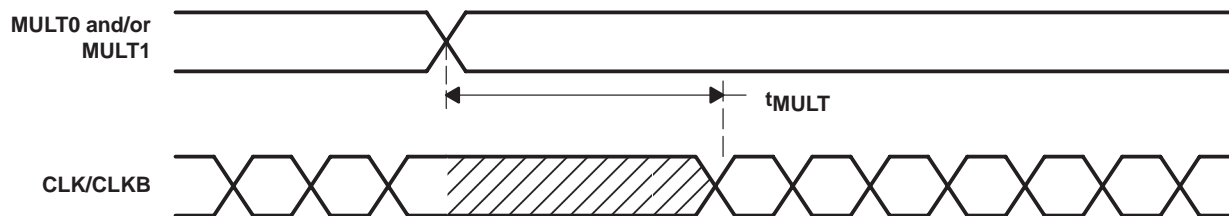
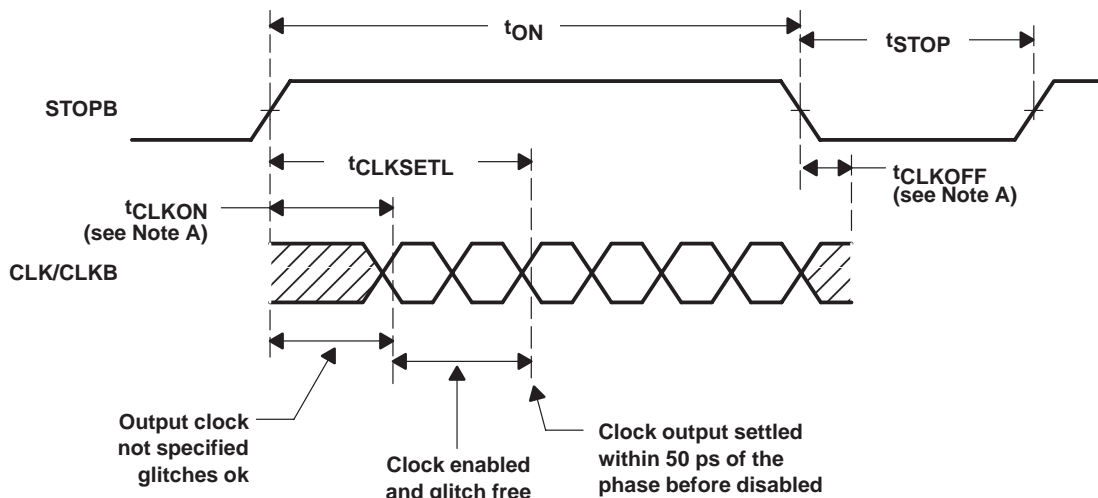

Figure 9. MULT Transition Timings



NOTE A: $V_{ref} = V_O \pm 200 \text{ mV}$

Figure 10. STOPB Transition Timings

PARAMETER MEASUREMENT INFORMATION

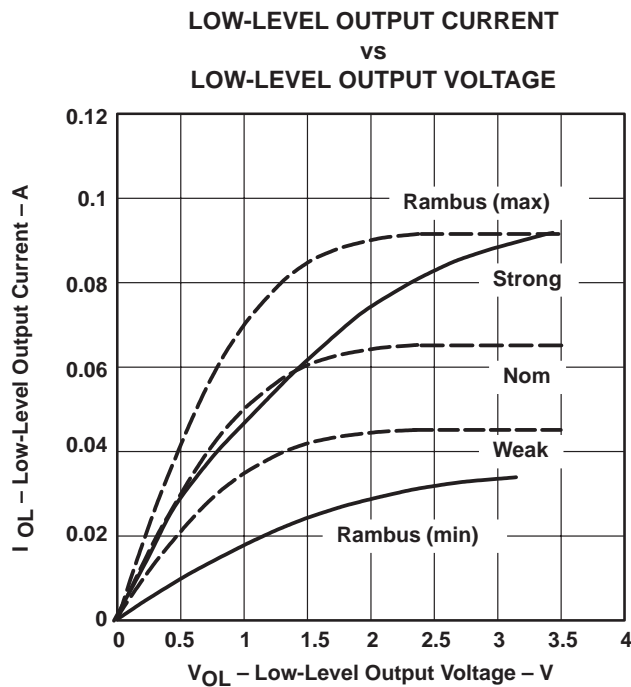
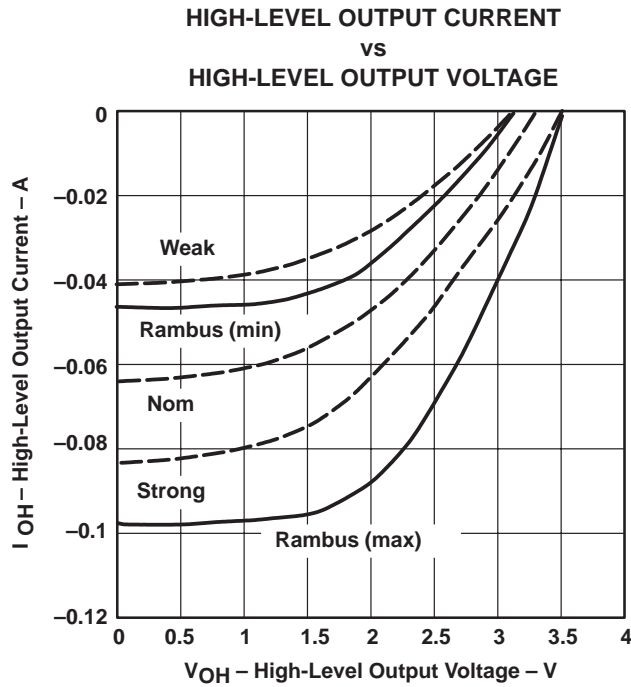

CDCR81 DIRECT RAMBUS™ CLOCK GENERATOR

SCAS606B – NOVEMBER 1998 – REVISED NOVEMBER 1999

MECHANICAL DATA

DBQ (R-PDSO-G**)

PLASTIC SMALL-OUTLINE PACKAGE

24-PIN SHOWN

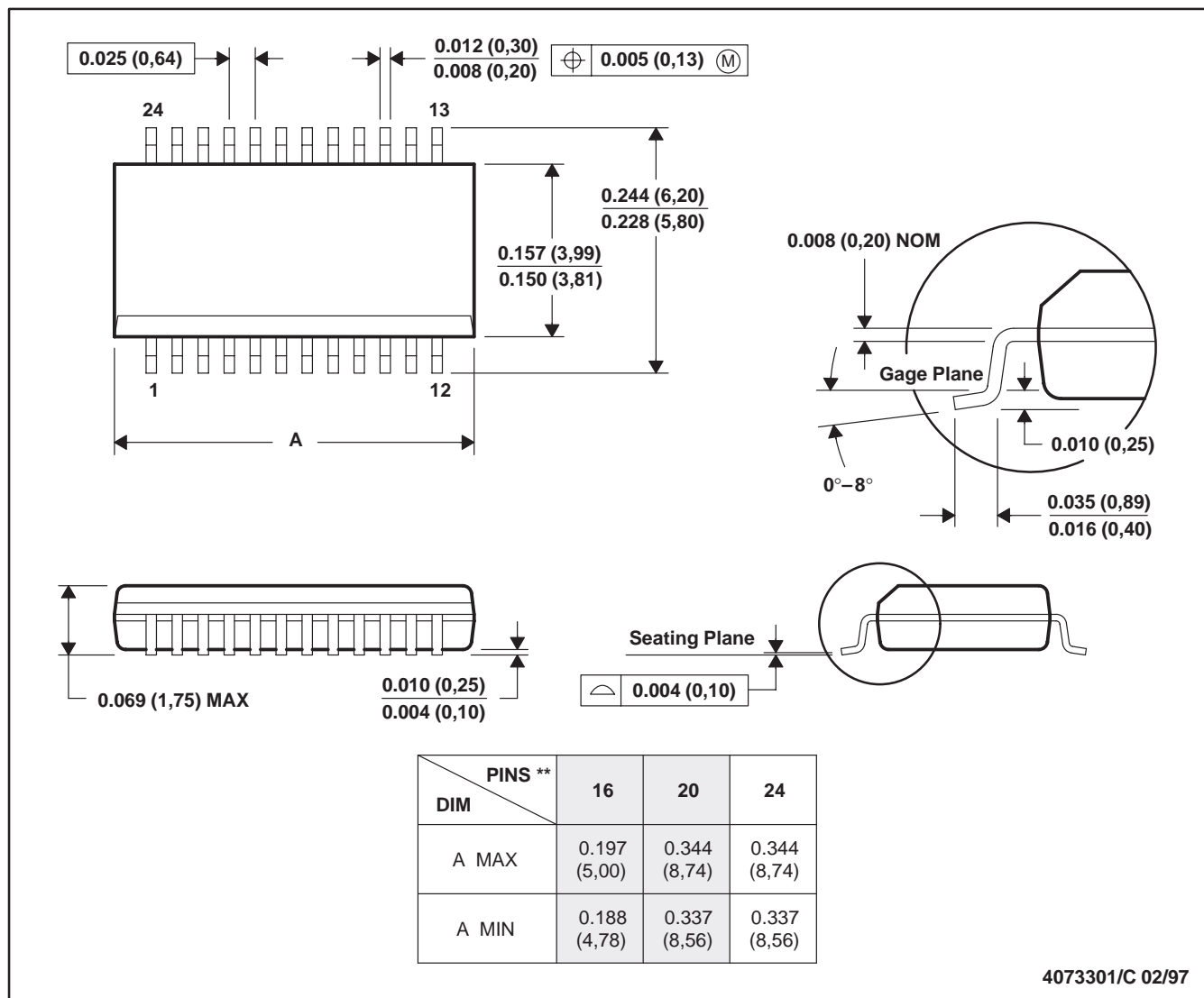

- NOTES: A. All linear dimensions are in inches (millimeters).
 B. This drawing is subject to change without notice.
 C. Body dimensions do not include mold flash or protrusion not to exceed 0.006 (0,15).
 D. Falls within JEDEC MO-137

PACKAGING INFORMATION

Orderable Device	Status ⁽¹⁾	Package Type	Package Drawing	Pins	Package Qty	Eco Plan ⁽²⁾	Lead/Ball Finish	MSL Peak Temp ⁽³⁾
CDCR81DBQ	OBSOLETE	SSOP/ QSOP	DBQ	24		TBD	Call TI	Call TI
CDCR81DBQR	ACTIVE	SSOP/ QSOP	DBQ	24	2500	Green (RoHS & no Sb/Br)	CU NIPDAU	Level-2-260C-1 YEAR
CDCR81DBQRG4	ACTIVE	SSOP/ QSOP	DBQ	24	2500	Green (RoHS & no Sb/Br)	CU NIPDAU	Level-2-260C-1 YEAR

⁽¹⁾ The marketing status values are defined as follows:

ACTIVE: Product device recommended for new designs.

LIFEBUY: TI has announced that the device will be discontinued, and a lifetime-buy period is in effect.

NRND: Not recommended for new designs. Device is in production to support existing customers, but TI does not recommend using this part in a new design.

PREVIEW: Device has been announced but is not in production. Samples may or may not be available.

OBSOLETE: TI has discontinued the production of the device.

⁽²⁾ Eco Plan - The planned eco-friendly classification: Pb-Free (RoHS), Pb-Free (RoHS Exempt), or Green (RoHS & no Sb/Br) - please check <http://www.ti.com/productcontent> for the latest availability information and additional product content details.

TBD: The Pb-Free/Green conversion plan has not been defined.

Pb-Free (RoHS): TI's terms "Lead-Free" or "Pb-Free" mean semiconductor products that are compatible with the current RoHS requirements for all 6 substances, including the requirement that lead not exceed 0.1% by weight in homogeneous materials. Where designed to be soldered at high temperatures, TI Pb-Free products are suitable for use in specified lead-free processes.

Pb-Free (RoHS Exempt): This component has a RoHS exemption for either 1) lead-based flip-chip solder bumps used between the die and package, or 2) lead-based die adhesive used between the die and leadframe. The component is otherwise considered Pb-Free (RoHS compatible) as defined above.

Green (RoHS & no Sb/Br): TI defines "Green" to mean Pb-Free (RoHS compatible), and free of Bromine (Br) and Antimony (Sb) based flame retardants (Br or Sb do not exceed 0.1% by weight in homogeneous material)

⁽³⁾ MSL, Peak Temp. -- The Moisture Sensitivity Level rating according to the JEDEC industry standard classifications, and peak solder temperature.

Important Information and Disclaimer:The information provided on this page represents TI's knowledge and belief as of the date that it is provided. TI bases its knowledge and belief on information provided by third parties, and makes no representation or warranty as to the accuracy of such information. Efforts are underway to better integrate information from third parties. TI has taken and continues to take reasonable steps to provide representative and accurate information but may not have conducted destructive testing or chemical analysis on incoming materials and chemicals. TI and TI suppliers consider certain information to be proprietary, and thus CAS numbers and other limited information may not be available for release.

In no event shall TI's liability arising out of such information exceed the total purchase price of the TI part(s) at issue in this document sold by TI to Customer on an annual basis.

TAPE AND REEL INFORMATION

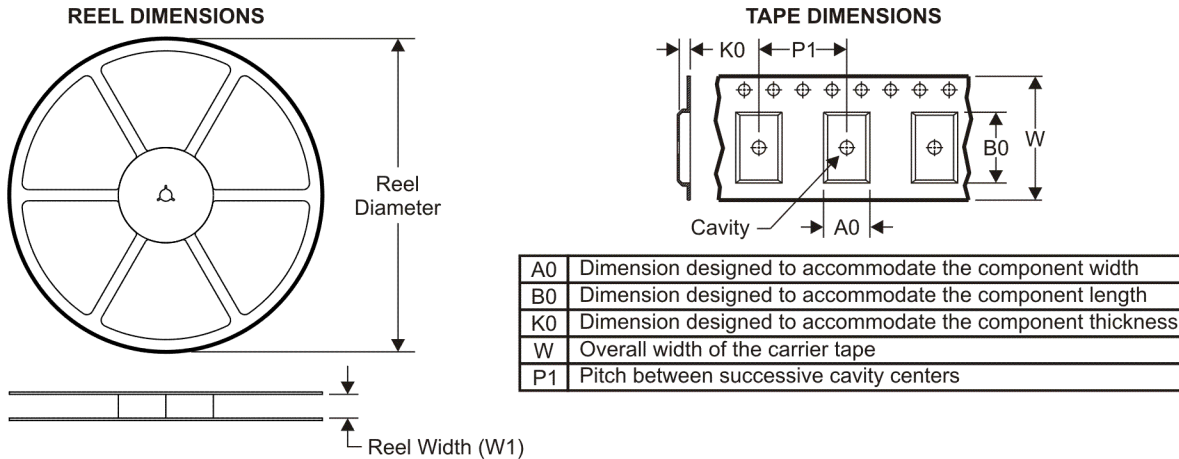

QUADRANT ASSIGNMENTS FOR PIN 1 ORIENTATION IN TAPE



*All dimensions are nominal

Device	Package Type	Package Drawing	Pins	SPQ	Reel Diameter (mm)	Reel Width W1 (mm)	A0 (mm)	B0 (mm)	K0 (mm)	P1 (mm)	W (mm)	Pin1 Quadrant
CDCR81DBQR	SSOP/QSOP	DBQ	24	2500	330.0	16.4	6.5	9.0	2.1	8.0	16.0	Q1

TAPE AND REEL BOX DIMENSIONS



*All dimensions are nominal

Device	Package Type	Package Drawing	Pins	SPQ	Length (mm)	Width (mm)	Height (mm)
CDCR81DBQR	SSOP/QSOP	DBQ	24	2500	346.0	346.0	33.0

IMPORTANT NOTICE

Texas Instruments Incorporated and its subsidiaries (TI) reserve the right to make corrections, modifications, enhancements, improvements, and other changes to its products and services at any time and to discontinue any product or service without notice. Customers should obtain the latest relevant information before placing orders and should verify that such information is current and complete. All products are sold subject to TI's terms and conditions of sale supplied at the time of order acknowledgment.

TI warrants performance of its hardware products to the specifications applicable at the time of sale in accordance with TI's standard warranty. Testing and other quality control techniques are used to the extent TI deems necessary to support this warranty. Except where mandated by government requirements, testing of all parameters of each product is not necessarily performed.

TI assumes no liability for applications assistance or customer product design. Customers are responsible for their products and applications using TI components. To minimize the risks associated with customer products and applications, customers should provide adequate design and operating safeguards.

TI does not warrant or represent that any license, either express or implied, is granted under any TI patent right, copyright, mask work right, or other TI intellectual property right relating to any combination, machine, or process in which TI products or services are used. Information published by TI regarding third-party products or services does not constitute a license from TI to use such products or services or a warranty or endorsement thereof. Use of such information may require a license from a third party under the patents or other intellectual property of the third party, or a license from TI under the patents or other intellectual property of TI.

Reproduction of TI information in TI data books or data sheets is permissible only if reproduction is without alteration and is accompanied by all associated warranties, conditions, limitations, and notices. Reproduction of this information with alteration is an unfair and deceptive business practice. TI is not responsible or liable for such altered documentation. Information of third parties may be subject to additional restrictions.

Resale of TI products or services with statements different from or beyond the parameters stated by TI for that product or service voids all express and any implied warranties for the associated TI product or service and is an unfair and deceptive business practice. TI is not responsible or liable for any such statements.

TI products are not authorized for use in safety-critical applications (such as life support) where a failure of the TI product would reasonably be expected to cause severe personal injury or death, unless officers of the parties have executed an agreement specifically governing such use. Buyers represent that they have all necessary expertise in the safety and regulatory ramifications of their applications, and acknowledge and agree that they are solely responsible for all legal, regulatory and safety-related requirements concerning their products and any use of TI products in such safety-critical applications, notwithstanding any applications-related information or support that may be provided by TI. Further, Buyers must fully indemnify TI and its representatives against any damages arising out of the use of TI products in such safety-critical applications.

TI products are neither designed nor intended for use in military/aerospace applications or environments unless the TI products are specifically designated by TI as military-grade or "enhanced plastic." Only products designated by TI as military-grade meet military specifications. Buyers acknowledge and agree that any such use of TI products which TI has not designated as military-grade is solely at the Buyer's risk, and that they are solely responsible for compliance with all legal and regulatory requirements in connection with such use.

TI products are neither designed nor intended for use in automotive applications or environments unless the specific TI products are designated by TI as compliant with ISO/TS 16949 requirements. Buyers acknowledge and agree that, if they use any non-designated products in automotive applications, TI will not be responsible for any failure to meet such requirements.

Following are URLs where you can obtain information on other Texas Instruments products and application solutions:

Products

Amplifiers	amplifier.ti.com
Data Converters	dataconverter.ti.com
DSP	dsp.ti.com
Clocks and Timers	www.ti.com/clocks
Interface	interface.ti.com
Logic	logic.ti.com
Power Mgmt	power.ti.com
Microcontrollers	microcontroller.ti.com
RFID	www.ti-rfid.com
RF/IF and ZigBee® Solutions	www.ti.com/lprf

Applications

Audio	www.ti.com/audio
Automotive	www.ti.com/automotive
Broadband	www.ti.com/broadband
Digital Control	www.ti.com/digitalcontrol
Medical	www.ti.com/medical
Military	www.ti.com/military
Optical Networking	www.ti.com/opticalnetwork
Security	www.ti.com/security
Telephony	www.ti.com/telephony
Video & Imaging	www.ti.com/video
Wireless	www.ti.com/wireless

Mailing Address: Texas Instruments, Post Office Box 655303, Dallas, Texas 75265
Copyright © 2008, Texas Instruments Incorporated

Looking for pricing, stock, or lifecycle information?

Click below to explore more details on WIN SOURCE:

 [View CDCR81DBQR](#) on WIN SOURCE

 [Texas Instruments](#) Information

Optimize Your Supply Chain with WIN SOURCE Solutions

-  Global Sourcing Solution
-  Obsolete Management
-  Cost Control Management
-  Shortage Management
-  Alternative Solution
-  Excess Inventory Management