



THE DATASHEET OF PCM1820EVM





ABSTRACT

This user's guide describes the function and use of the PCM1820EVM /PCM1821EVM/ PCM1822EVM / PCM1820Q1EVM/PCM1821Q1EVM/PCM1822Q1EVM evaluation modules. This document includes the hardware configuration instructions, a quick-start guide, jumper and connector descriptions, schematics, and printed-circuit board (PCB) layout that demonstrate TI's recommended practices for these devices .

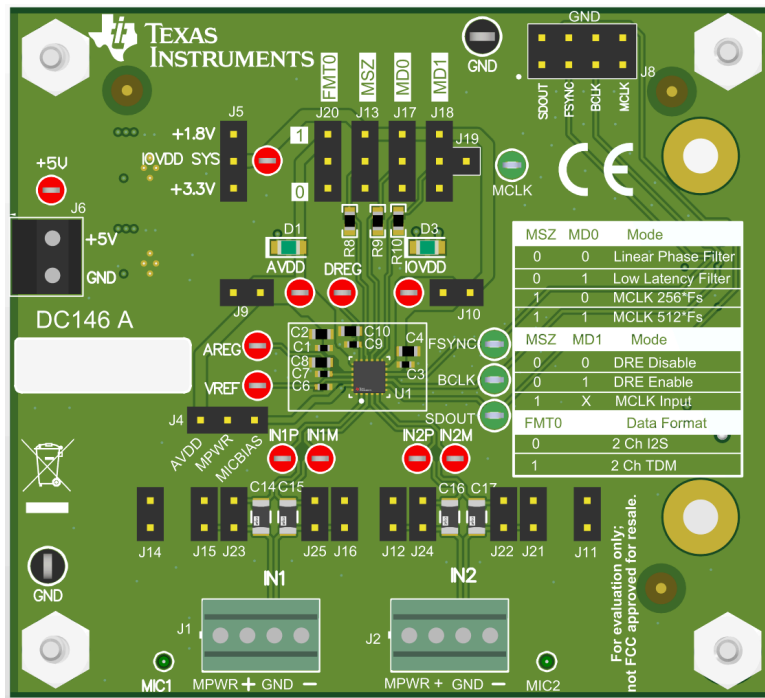

Figure 1-1. EVM BOARD

Table of Contents

1 Introduction	3
2 Power Supply	3
3 Hardware Configuration	4
4 PCM182xEVM /PCM182xQ1EVM Inputs	6
4.1 Onboard Microphone Inputs.....	6
4.2 Line Inputs.....	7
5 Layer Plots	8
6 Schematics	12
7 Bill of Materials	13
8 Revision History	15

List of Figures

Figure 1-1. EVM BOARD.....	1
Figure 2-1. PCM182x /PCM182x-Q1 Power Supply.....	3
Figure 4-1. PCM182x /PCM182x-Q1 Input Architecture.....	6
Figure 4-2. PCM182x/PCM182x-Q1 Onboard Microphones.....	7
Figure 4-3. PCM182x/ PCM182x-Q1 Line Inputs.....	7
Figure 5-1. Top Layer.....	8
Figure 5-2. Power Plane 1.....	9
Figure 5-3. Power Plane 2.....	10
Figure 5-4. Bottom Layer.....	11
Figure 6-1. Schematic.....	12

Trademarks

Burr-Brown™ is a trademark of Texas Instruments.

All trademarks are the property of their respective owners.

1 Introduction

The PCM182xEVM/ PCM182xQ1EVM is an evaluation module (EVM) designed to demonstrate the performance and functionality of the PCM182x / PCM182x-Q1 device. The devices covered are PCM1820/PCM1821/ PCM1822/PCM1820-Q1/PCM1821-Q1/PCM1822-Q1. The PCM182x/ PCM182x-Q1 is a high-performance audio analog-to-digital converter (ADC) that is configured through logic-level mode selection pins and does not require a digital interface such as I2C or SPI to configure registers. As such, no software is necessary to interface with the EVM. The EVM is powered with a single 5-V supply. Access to the converter output is provided on the audio serial interface in I2S or TDM format.

2 Power Supply

The PCM182xEVM/PCM182xQ1EVM can be powered with a single 5-V power supply connected to J6. Onboard low dropout regulators convert the 5-V supply to the 3.3-V and 1.8-V rails used by the ADC. The analog supply, AVDD, is fixed at 3.3 V. The digital supply, IOVDD, can be set to either 1.8 V or 3.3 V with J5. It is also possible to power the ADC directly by removing J9 and J5 and applying a voltage directly to the AVDD and IOVDD test points. Note that if this is done, it is important to keep J10 populated (or ensure there is a path between the pins) as this jumper connects the applied IOVDD to the mode selection pins and other circuitry that relies on IOVDD.

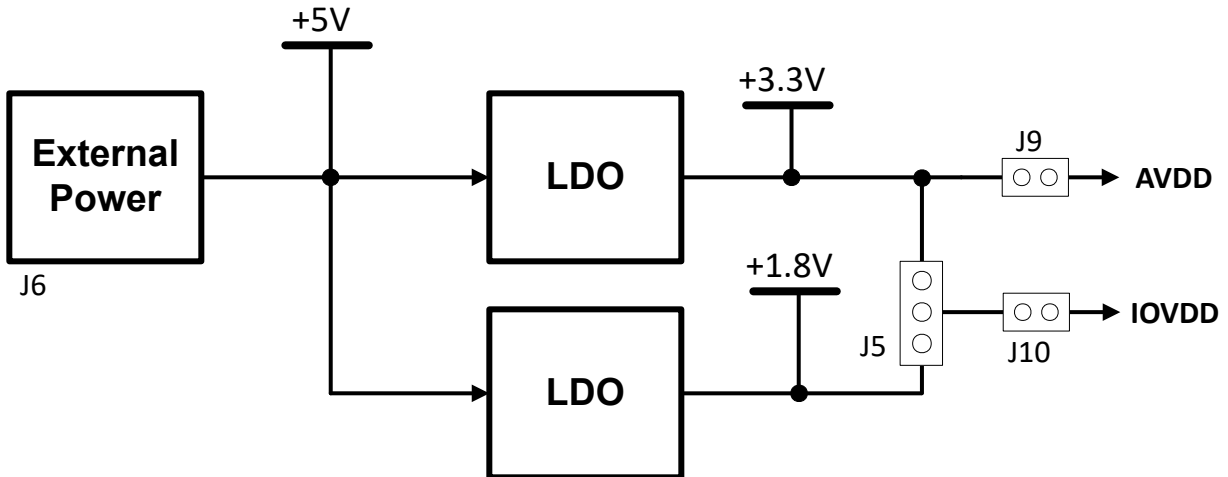

Figure 2-1. PCM182x /PCM182x-Q1 Power Supply

3 Hardware Configuration

The format of the audio data and the operating mode of the ADC are controlled by the following pins: MD0, MD1, MSZ, and FMT0. These signals are referenced to IOVDD and can be set to high (1) or low (0). If no shunt is installed, then a 47-k Ω pulldown resistor will set the pin low so that the ADC remains in a defined state. [Table 3-1](#) shows the header numbers and their pin functions and [Table 3-2](#), [Table 3-2](#) and [Table 3-2](#) show the possible modes and output formats. The MSZ pin selects whether the device is a master or a slave on the audio bus. When MSZ is pulled high, the device is in master mode and MD1 becomes an input for MCLK. A shunt connecting J19 to the center pin of J18 will route the MCLK signal provided on J8 to the MD1 pin on the ADC to allow for easy interfacing with audio measurement equipment.

Table 3-1. PCM182xEVM /PCM182xQ1EVM Headers and Jumpers

Designator	Function
J1	Differential line/mic input 1
J2	Differential line/mic input 2
J4	MICBIAS Selection
J5	IOVDD-SYS voltage Selection (1.8V or 3.3V)
J6	+5V input
J7	AC-MB Connector
J8	Audio Serial Interface header
J9	Connect AVDD to onboard 3.3V regulator
J10	Connect IOVDD to onboard regulator
J11	Connect MICBIAS to onboard MIC2
J12	Connect MIC2 OUT+ to ADC IN2P
J13	MSZ select
J14	Connect MICBIAS to onboard MIC1
J15	Connect MIC1 OUT+ to ADC IN1P
J16	Connect MIC1 OUT- to ADC IN1M
J17	MD0 select
J18	MD1 select
J19	MCLK to MD1
J20	FMT0 select
J21	Connect MIC2 OUT- to ADC IN2M
J22	IN2M capacitor bypass
J23	IN1P capacitor bypass
J24	IN2P capacitor bypass
J25	IN1M capacitor bypass

Table 3-2. PCM182xEVM /PCM182xQ1EVM MD0 Modes

MD0 Modes		
MD0	MSZ (0 = Slave, 1 = Master)	MD0 Functional Mode
0	0	Linear phase filters are used for the decimation in slave mode. For master mode, the device always use linear phase filters for the decimation.
0	1	System clock with frequency $256 \times f_S$ connected to the MD1 pin as MCLK
1	0	System clock with frequency $512 \times f_S$ connected to the MD1 pin as MCLK
1	1	Low latency filters are used for the decimation in slave mode. For master mode, the device always use linear phase filters for the decimation.

Table 3-3. PCM182xEVM /PCM182xQ1EVM MD1 Modes

MD1 Modes		
<i>MD1</i>	<i>MSZ (0 = Slave, 1 = Master)</i>	<i>MD0 Functional Mode</i>
0	0	DRE Disabled
1	0	The DRE is enabled with DRE_LVL = -36 dB and DRE_MAXGAIN = 24 dB
MCLK	1	MCLK input in master mode

Table 3-4. PCM182xEVM /PCM182xQ1EVM Audio Output Format

Audio Output Data Format	
<i>FMT0</i>	<i>Audio Serial Interface Format</i>
0	2-channel output with inter IC sound (I2S) mode
1	2-channel output with time division multiplexing (TDM) mode

All hardware pins are tied low by default, placing the device in slave mode with a linear phase filter, DRE disabled, and 2-channel I2S audio output. Note that DRE is not supported for PCM1821/PCM1821-Q1 and only applies to PCM1820/PCM1822/PCM1820-Q1/PCM1822-Q1. For more information on the operating modes of the PCM182x device, see the PCM182x Stereo Channel, 32-Bit, 192-kHz, Burr-Brown™ Audio ADC data sheet.

4 PCM182xEVM /PCM182xQ1EVM Inputs

The PCM1820/PCM1820-Q1 device is intended to be driven with differential line or microphone inputs. Each of the inputs has a 1- μ F AC coupling film capacitor. Coupled with the 2.5-k Ω input impedance of PCM1820/PCM1820-Q1, this sets the high pass filter cutoff frequency at approximately 63-Hz. PCM1821/PCM1821-Q1 has an input impedance of 10-k Ω , setting the cutoff frequency at 16-Hz. This can be adjusted by replacing the input AC coupling capacitors on the EVM if necessary. Figure 4-1 shows the architecture of the inputs to the evaluation module. The EVM supports a differential full scale input range of 2 VRMS with an AVDD of 3.3 V.

Please Note: PCM1822EVM/PCM1822Q1EVM is set up to support single ended inputs.

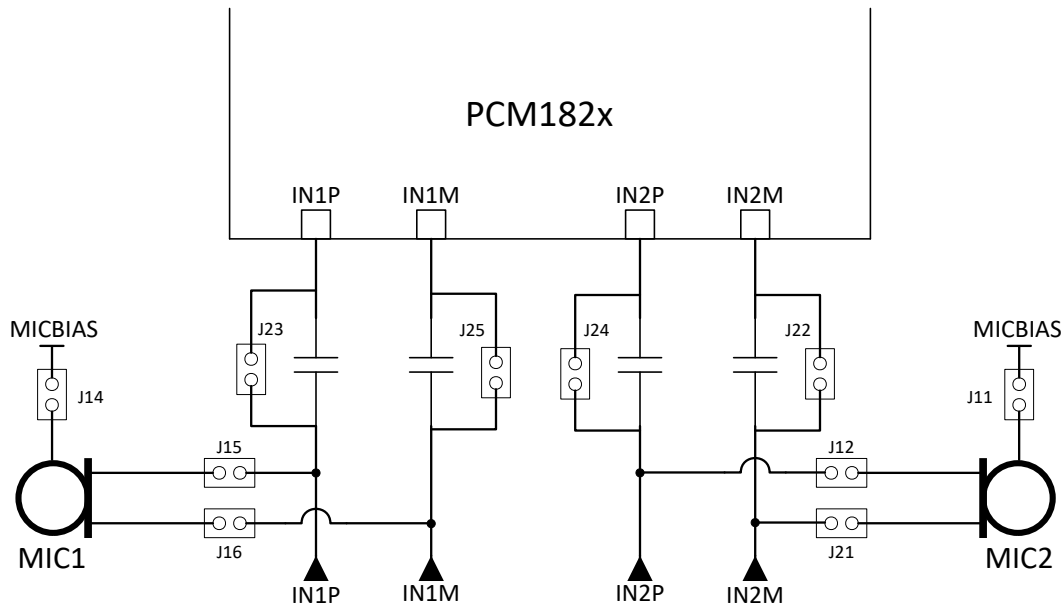

Figure 4-1. PCM182x /PCM182x-Q1 Input Architecture

4.1 Onboard Microphone Inputs

PCM182x EVM/PCM182xQ1 EVM has two onboard differential microphones that can be routed to the inputs with jumpers. The microphones require a bias be applied to MPWR. MPWR can be tied to AVDD on J4, or to MICBIAS if using a device that supports this feature. Note that the PCM182x/PCM182x-Q1 do not have an integrated MICBIAS and this option is provided for future devices that might incorporate this feature. The following jumpers need to be installed to use the onboard mics: J4, J11, J12, J14, J15, J16, and J21.

If the onboard mics are used, leave the J1 and J2 headers unconnected to preserve the microphone performance.

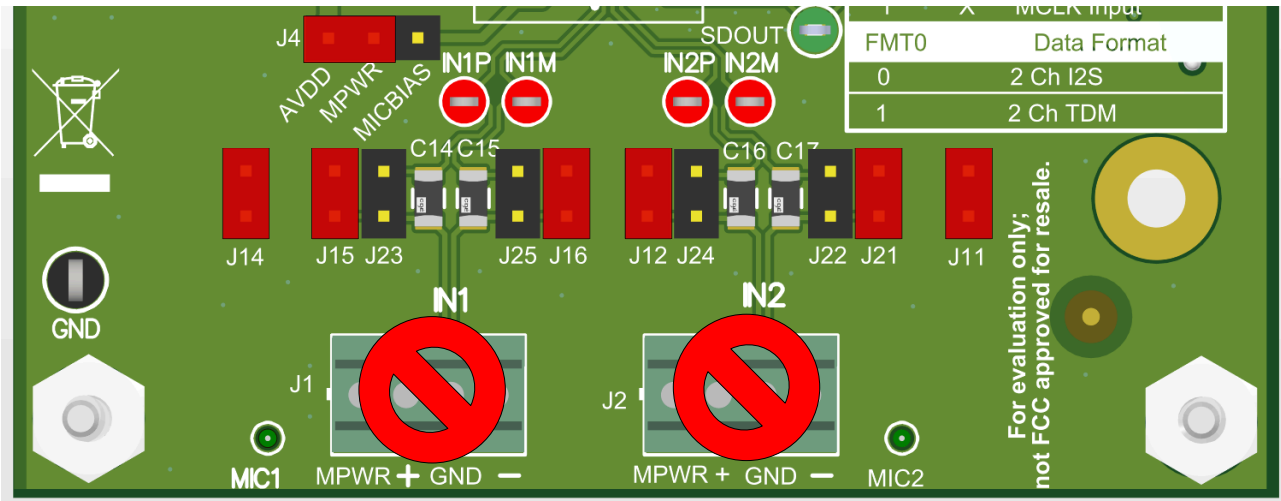

Figure 4-2. PCM182x/PCM182x-Q1 Onboard Microphones

4.2 Line Inputs

For the line input configuration, shown in Figure 4-3, the PCM1820/PCM1820-Q1 /PCM1821/PCM1821-Q1 captures the audio signal provided through terminals J1 (IN1) and J2 (IN2). The input accepted in this mode is a differential, 2 VRMS, full-scale audio signal. Single-ended inputs are not supported by the PCM1820/PCM1820-Q1 device and it is recommended to keep the inputs AC coupled.

Please Note: PCM1822EVM/PCM1822Q1EVM is set up to support single ended inputs. Resistance R3 and R5 are mounted as 0 ohms.

PCM1822/PCM1822-Q1 accepts , 1 VRMS, single ended/differential full-scale audio signal

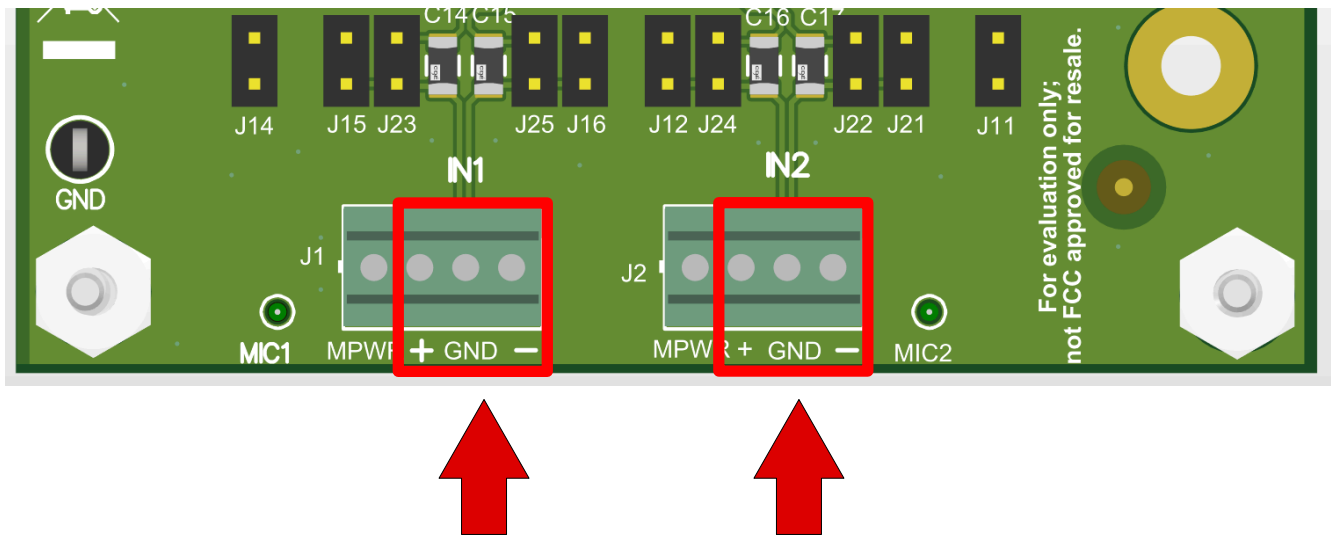

Figure 4-3. PCM182x/PCM182x-Q1 Line Inputs

5 Layer Plots

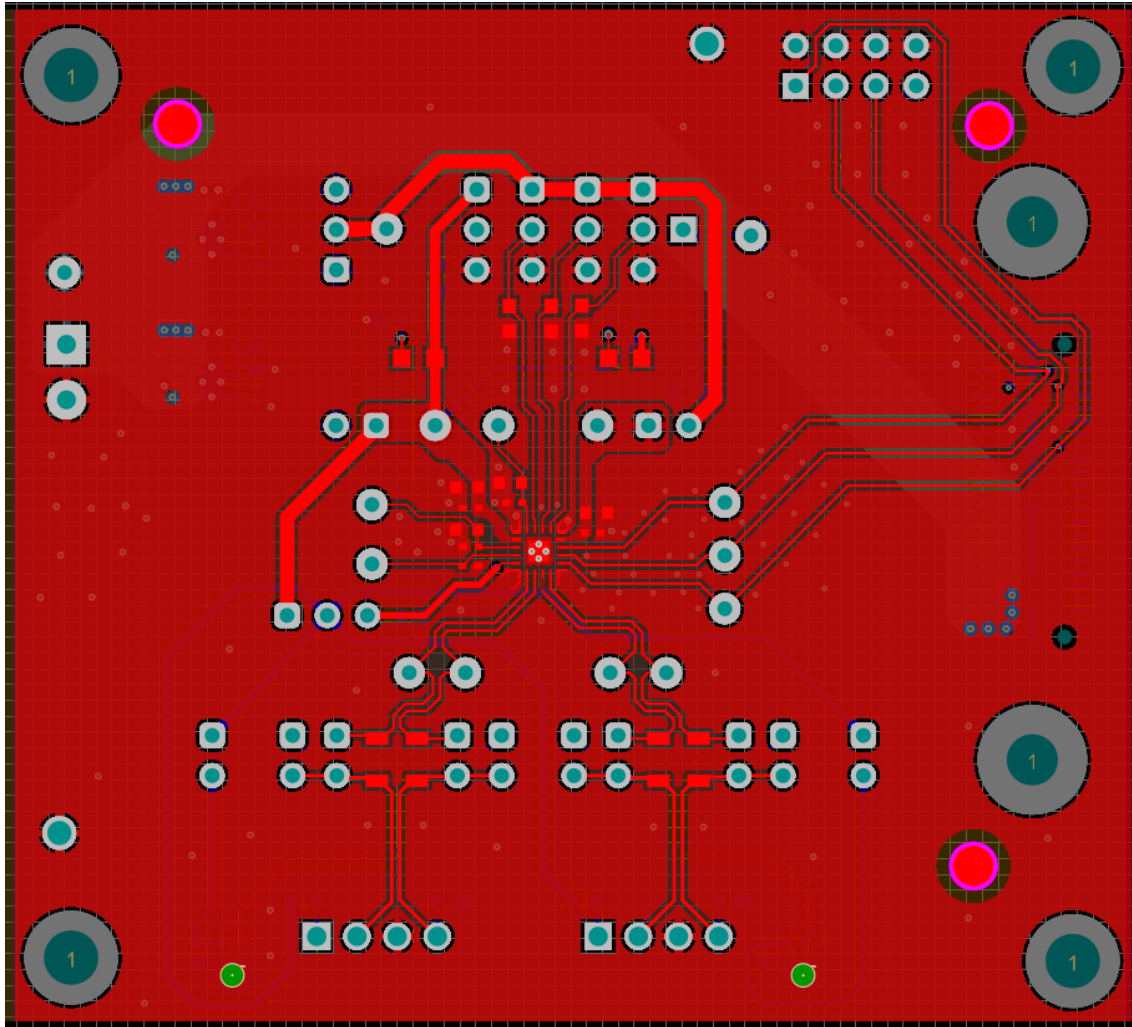
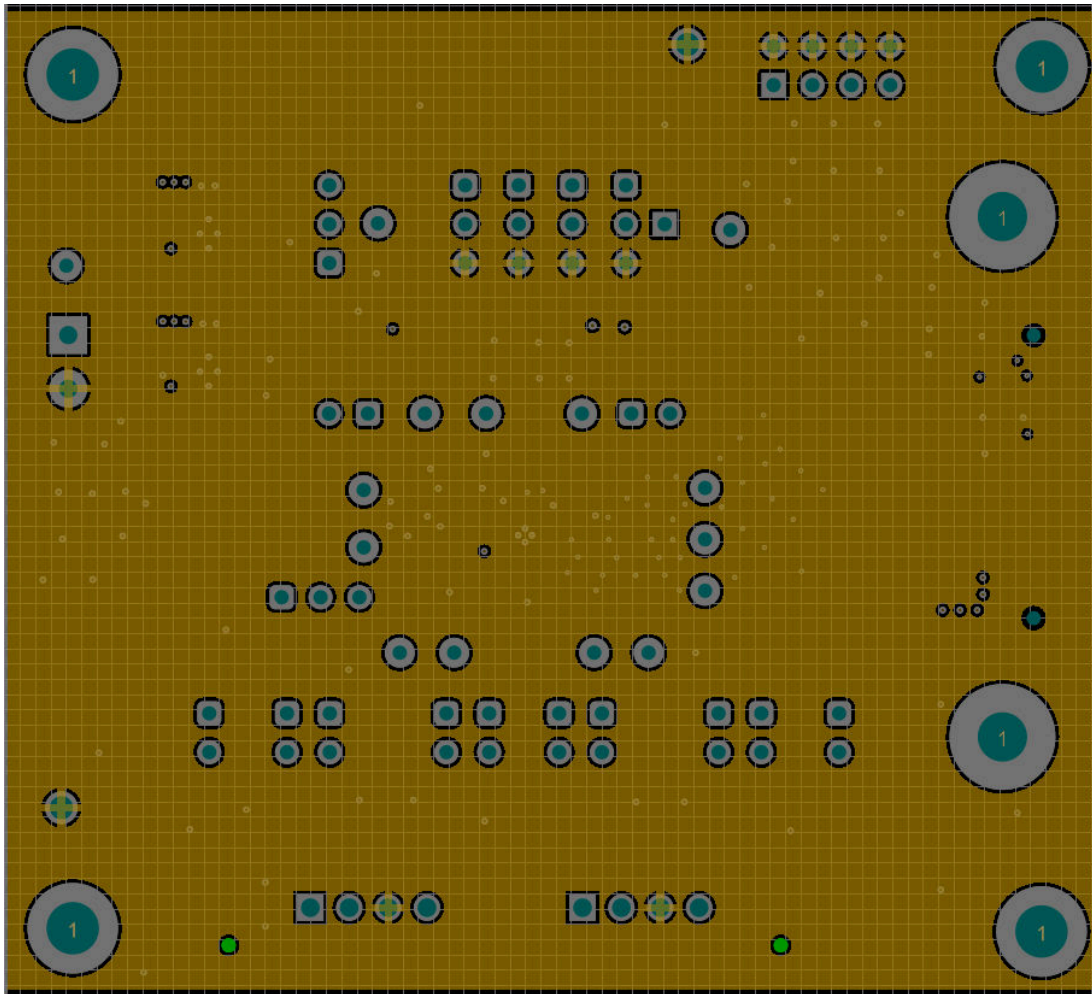

Figure 5-1. Top Layer



C

Figure 5-2. Power Plane 1

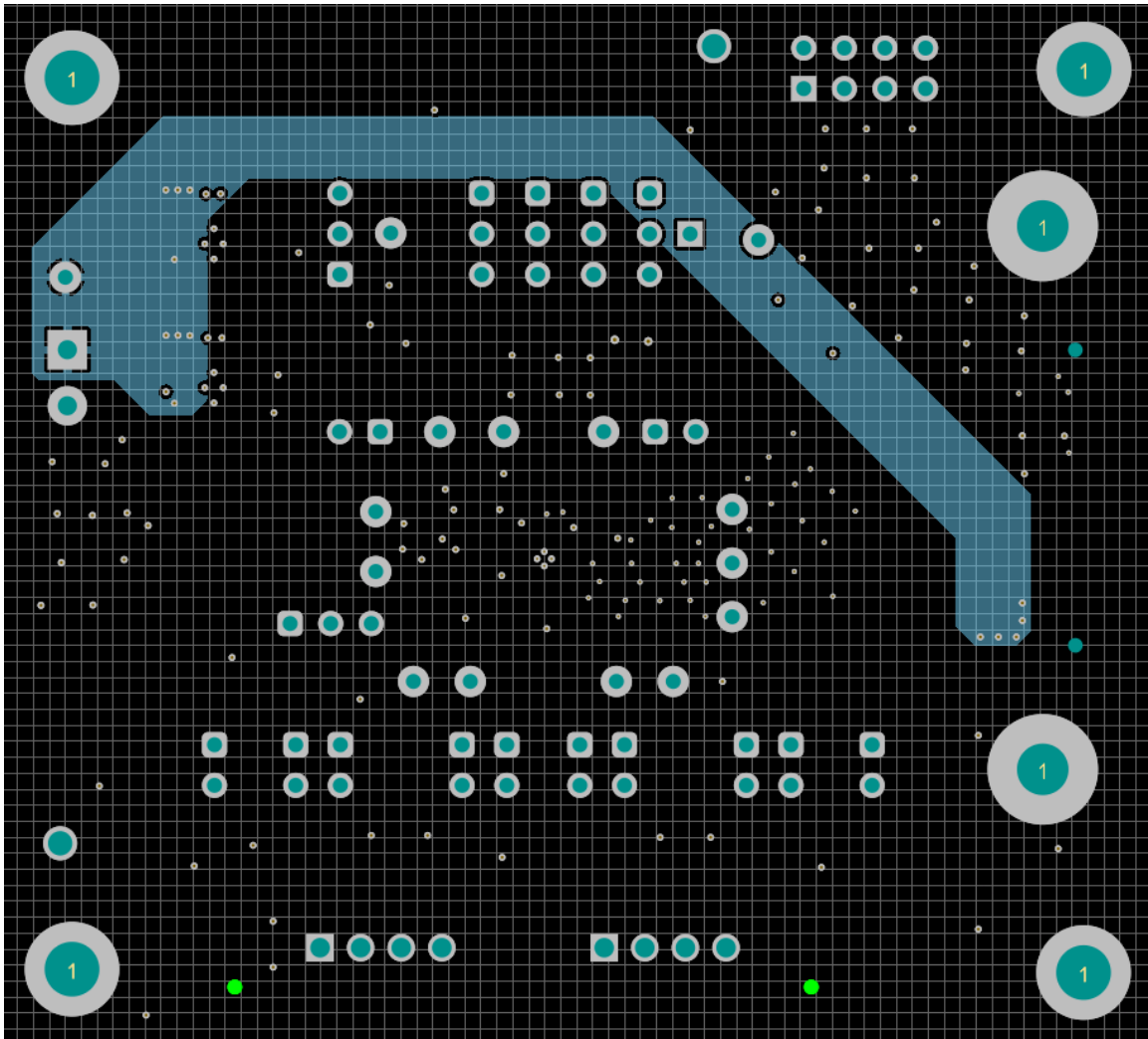

Figure 5-3. Power Plane 2

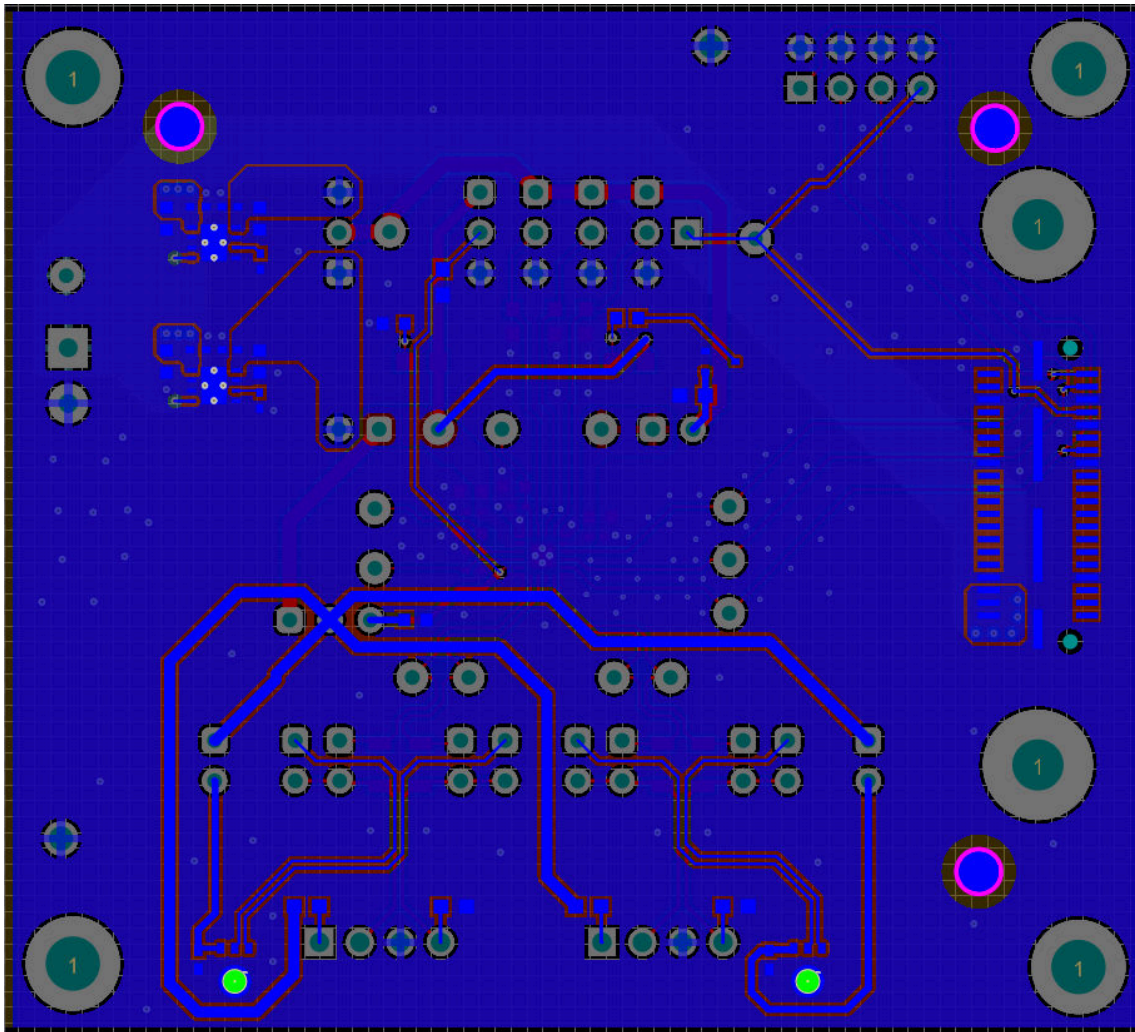

Figure 5-4. Bottom Layer

6 Schematics

Figure 6-1 illustrates the EVM schematic.

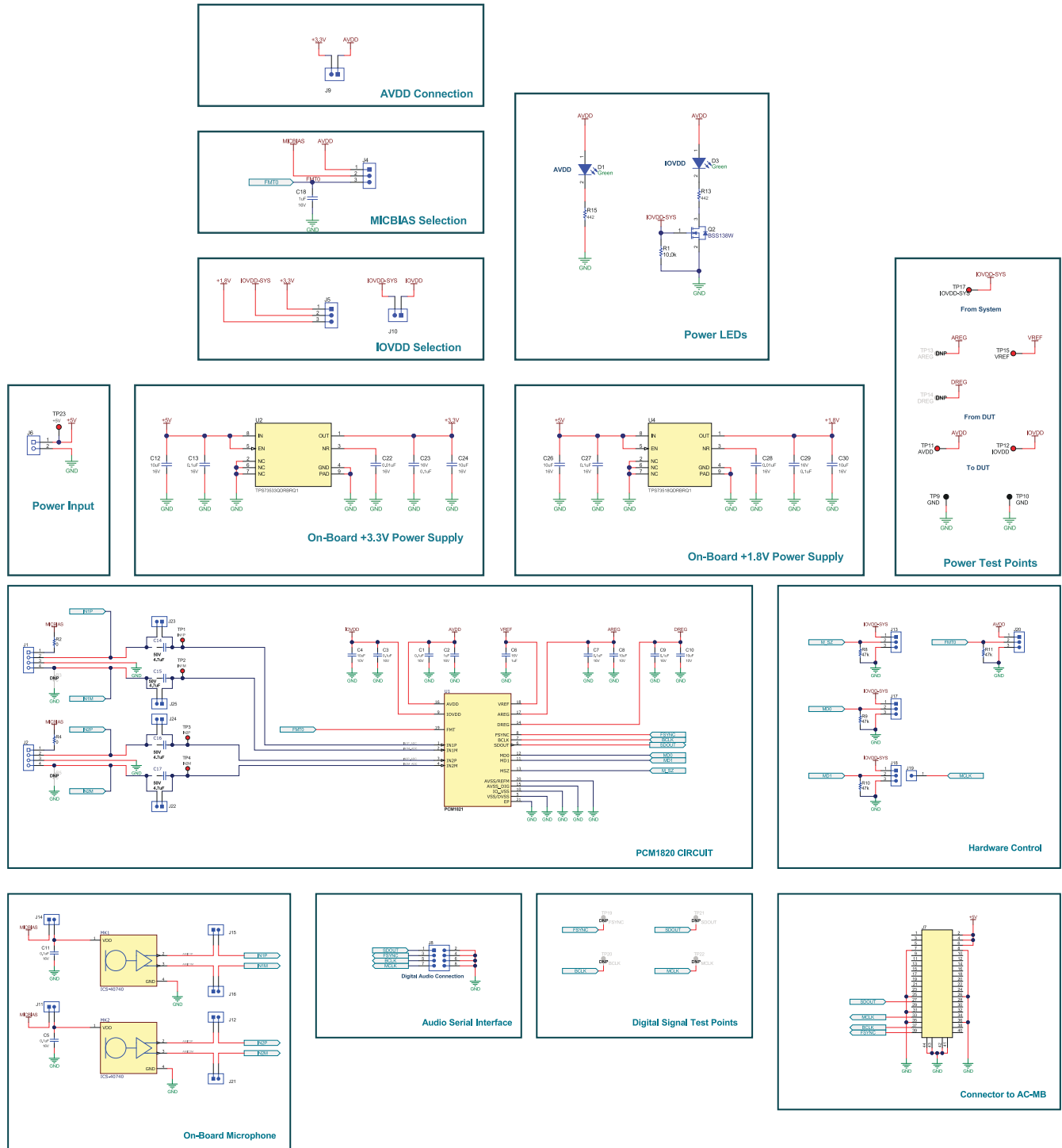

Figure 6-1. Schematic

7 Bill of Materials

Designator	Quantity	Value	Description	PackageReference	PartNumber	Manufacturer
C1, C3, C5, C7, C9, C11, C13, C23, C27, C29	10	0.1uF	CAP, CERM, 0.1 uF, 16 V, +/- 10%, X7R, 0402	0402	885012205037	Wurth Elektronik
C2	1	1uF	CAP, CERM, 1 uF, 16 V, +/- 10%, X7R, 0603	0603	885012206052	Wurth Elektronik
C4, C8, C10	3	10uF	CAP, CERM, 10 uF, 10 V, +/- 20%, X5R, 0603	0603	C1608X5R1A106M080AC	TDK
C6	1	1uF	CAP, CERM, 1 uF, 16 V, +/- 10%, X5R, 0402	0402	EMK105BJ105K VHF	Taiyo Yuden
C12, C24, C26, C30	4	10uF	CAP, CERM, 10 uF, 16 V, +/- 20%, X5R, 0603	0603	EMK107BBJ106 MA-T	Taiyo Yuden
C14, C15, C16, C17	4	4.7uF	CAP, CERM, 4.7 uF, 50 V, +/- 10%, X7R, 1206	1206	GRM31CR71H475KA12L	MuRata
C18	1	1uF	CAP, CERM, 1 uF, 16 V, +/- 10%, X7R, 0603	0603	EMK107B7105K A-T	Taiyo Yuden
C22, C28	2	0.01uF	CAP, CERM, 0.01 uF, 16 V, +/- 10%, X7R, 0402	0402	520L103KT16T	AT Ceramics
D1, D3	2	Green	LED, Green, SMD	LED_0805	LTST-C170KGKT	Lite-On
H1, H2, H3, H4	4		Small nylon hex nut, 0.10 thick with a 0.250 outside diameter and a 4-40 threading	Hex Nut,4-40 Thread, 250" Head Dia	9605	Keystone
H5, H6, H7, H8	4		Standoff, Hex, Male/Female, 4-40, Nylon, 1/2"	Standoff, Hex, Male/Female, 4-40, Nylon, 1/2"	4802	Keystone
J1, J2	2		Terminal Block, 2.54mm, 4x1, Brass, TH	Terminal Block, 2.54mm, 4-pole, TH	OSTVN04A150	On-Shore Technology
J4, J5, J13, J17, J18, J20	6		Header, 100mil, 3x1, Gold, TH	3x1 Header	TSW-103-07-G-S	Samtec
J6	1		Terminal Block, 3.5mm Pitch, 2x1, TH	7.0x8.2x6.5mm	ED555/2DS	On-Shore Technology
J7	1		Connector, Header, High Speed, 20 pairs, SMT	QTE-020-01-X-D-A	QTE-020-01-L-D-A	Samtec
J8	1		Header, 100mil, 4x2, Gold, TH	4x2 Header	TSW-104-07-G-D	Samtec
J9, J10, J11, J12, J14, J15, J16, J21, J22, J23, J24, J25	12		Header, 100mil, 2x1, Gold, TH	2x1 Header	TSW-102-07-G-S	Samtec
J19	1		Header, 100mil, 1pos, Gold, TH	Testpoint	TSW-101-07-G-S	Samtec
LBL1	1		Thermal Transfer Printable Labels, 0.650" W x 0.200" H - 10,000 per roll	PCB Label 0.650 x 0.200 inch	THT-14-423-10	Brady

Designator	Quantity	Value	Description	PackageReference	PartNumber	Manufacturer
MK1, MK2	2		77Hz ~ 20kHz Analog Microphone MEMS (Silicon) 1.5V ~ 3.63V Omnidirectional (-37.5dB ±1dB @ 94dB SPL) Solder Pads	LGA4	ICS-40740	TDK
Q2	1	50V	MOSFET, N-CH, 50 V, 0.21 A, SOT-323	SOT-323	BSS138W	Fairchild Semiconductor
R1	1	10.0k	RES, 10.0 k, 1%, 0.1 W, 0603	0603	CRCW060310K0 FKEA	Vishay-Dale
R2, R4	2	0	RES, 0, 5%, 0.1 W, 0603	0603	CRCW06030000 Z0EA	Vishay-Dale
R8, R9, R10, R11	4	47k	RES, 47 k, 5%, 0.1 W, 0603	0603	RC0603JR-0747 KL	Yageo
R13, R15	2	442	RES, 442, 1%, 0.1 W, AEC-Q200 Grade 0, 0603	0603	CRCW0603442R FKEA	Vishay-Dale
SH1, SH2, SH3, SH4, SH5, SH6, SH7, SH8, SH9, SH10, SH11, SH12, SH13, SH14	14	1x2	Shunt, 100mil, Gold plated, Black	Shunt	SNT-100-BK-G	Samtec
TP1, TP2, TP3, TP4, TP11, TP12, TP15, TP17, TP23	9		Test Point, Miniature, Red, TH	Red Miniature Testpoint	5000	Keystone
TP9, TP10	2		Test Point, Multipurpose, Black, TH	Black Multipurpose Testpoint	5011	Keystone
U1	1		PCM1821 - 106dB HW Stereo ADC	WQFN20	PCM1821IRTER	Texas Instruments
U2	1		500-mA, Low Quiescent Current, Low-Noise, High PSRR, Low-Dropout Linear Regulator for Automotive, DRB0008B (VSON-8)	DRB0008B	TPS73533QDRB RQ1	Texas Instruments
U4	1		500-mA, Low Quiescent Current, Low-Noise, High PSRR, Low-Dropout Linear Regulator for Automotive, DRB0008B (VSON-8)	DRB0008B	TPS73518QDRB RQ1	Texas Instruments
FID1, FID2, FID3, FID4, FID5, FID6	0		Fiducial mark. There is nothing to buy or mount.	N/A	N/A	N/A
R3, R5	0	0	RES, 0, 5%, 0.1 W, 0603	0603	CRCW06030000 Z0EA	Vishay-Dale

Designator	Quantity	Value	Description	PackageReference	PartNumber	Manufacturer
TP13, TP14	0		Test Point, Miniature, Red, TH	Red Miniature Testpoint	5000	Keystone
TP19, TP20, TP21, TP22	0		Test Point, Miniature, Green, TH	Green Miniature Testpoint	5116	Keystone

8 Revision History

NOTE: Page numbers for previous revisions may differ from page numbers in the current version.

Changes from Revision * (February 2021) to Revision A (March 2022) Page

- Updated User's Guide to include references to PCM1820-Q1, PCM1821-Q1 and PCM1822-Q1..... [1](#)

IMPORTANT NOTICE AND DISCLAIMER

TI PROVIDES TECHNICAL AND RELIABILITY DATA (INCLUDING DATA SHEETS), DESIGN RESOURCES (INCLUDING REFERENCE DESIGNS), APPLICATION OR OTHER DESIGN ADVICE, WEB TOOLS, SAFETY INFORMATION, AND OTHER RESOURCES "AS IS" AND WITH ALL FAULTS, AND DISCLAIMS ALL WARRANTIES, EXPRESS AND IMPLIED, INCLUDING WITHOUT LIMITATION ANY IMPLIED WARRANTIES OF MERCHANTABILITY, FITNESS FOR A PARTICULAR PURPOSE OR NON-INFRINGEMENT OF THIRD PARTY INTELLECTUAL PROPERTY RIGHTS.

These resources are intended for skilled developers designing with TI products. You are solely responsible for (1) selecting the appropriate TI products for your application, (2) designing, validating and testing your application, and (3) ensuring your application meets applicable standards, and any other safety, security, regulatory or other requirements.

These resources are subject to change without notice. TI grants you permission to use these resources only for development of an application that uses the TI products described in the resource. Other reproduction and display of these resources is prohibited. No license is granted to any other TI intellectual property right or to any third party intellectual property right. TI disclaims responsibility for, and you will fully indemnify TI and its representatives against, any claims, damages, costs, losses, and liabilities arising out of your use of these resources.

TI's products are provided subject to [TI's Terms of Sale](#) or other applicable terms available either on ti.com or provided in conjunction with such TI products. TI's provision of these resources does not expand or otherwise alter TI's applicable warranties or warranty disclaimers for TI products.

TI objects to and rejects any additional or different terms you may have proposed.

Mailing Address: Texas Instruments, Post Office Box 655303, Dallas, Texas 75265
Copyright © 2022, Texas Instruments Incorporated

Looking for pricing, stock, or lifecycle information?

Click below to explore more details on WIN SOURCE:

 [View PCM1820EVM](#) on WIN SOURCE

 [Texas Instruments](#) Information

Optimize Your Supply Chain with WIN SOURCE Solutions

-  Global Sourcing Solution
-  Obsolete Management
-  Cost Control Management
-  Shortage Management
-  Alternative Solution
-  Excess Inventory Management