



**THE DATASHEET OF
PCA9670PW,118**





PCA9670

Remote 8-bit I/O expander for Fm+ I²C-bus with reset

Rev. 3 — 30 May 2013

Product data sheet

1. General description

The PCA9670 provides general-purpose remote I/O expansion via the two-wire bidirectional I²C-bus (serial clock (SCL), serial data (SDA)).

The devices consist of eight quasi-bidirectional ports, 1 MHz 30 mA drive I²C-bus interface, three hardware address inputs and a reset input operating between 2.3 V and 5.5 V. 1 MHz I²C-bus Fast-mode Plus (Fm+) can support PWM dimming of LEDs, and higher I²C-bus drive 30 mA allows more devices to be on the bus without the need for bus buffers. The quasi-bidirectional port can be independently assigned as an input to monitor interrupt status or keypads, or as an output to activate indicator devices such as LEDs. The system master can read from the input port or write to the output port through a single register.

The low current consumption of 2.5 μ A (typical, static) is great for mobile applications and the latched output ports have 25 mA high current sink drive capability for directly driving LEDs.

The PCA9670 has three hardware address pins and allows up to 64 of these PCA9670 I/O expanders on the same I²C-bus without the need for bus buffers, supporting up to 512 I/Os (for example, 512 LEDs).

The internal Power-On Reset (POR) and active LOW hardware reset pin ($\overline{\text{RESET}}$) initialize the I/Os as inputs with a weak internal pull-up 100 μ A current source.

2. Features and benefits

- I²C-bus to parallel port expander
- 1 MHz I²C-bus interface (Fast-mode Plus I²C-bus)
- SDA with 30 mA sink capability for 4000 pF buses
- Operating supply voltage 2.3 V to 5.5 V with 5.5 V tolerant I/Os held to V_{DD} with 100 μ A current source
- 8-bit remote I/O pins that default to inputs at power-up
- Latched outputs with 25 mA sink capability for directly driving LEDs
- Total package sink capability of 200 mA
- Active LOW reset input
- Sixty-four programmable slave addresses using three address pins
- Readable device ID (manufacturer, device type, and revision)
- Software reset
- Low standby current (2.5 μ A typical)
- -40 °C to +85 °C operation



- ESD protection exceeds 2000 V HBM per JESD22-A114 and 1000 V CDM per JESD22-C101
- Latch-up testing is done to JEDEC standard JESD78 which exceeds 100 mA
- Packages offered: SO16, TSSOP16 and HVQFN16

3. Applications

- LED signs and displays
- Servers
- Keypads
- Industrial control
- Medical equipment
- PLCs
- Cellular telephones
- Mobile devices
- Gaming machines
- Instrumentation and test measurement

4. Ordering information

Table 1. Ordering information

Type number	Topside marking	Package		
		Name	Description	Version
PCA9670BS	670	HVQFN16	plastic thermal enhanced very thin quad flat package; no leads; 16 terminals; body 3 × 3 × 0.85 mm	SOT758-1
PCA9670D	PCA9670D	SO16	plastic small outline package; 16 leads; body width 7.5 mm	SOT162-1
PCA9670PW	PCA9670	TSSOP16	plastic thin shrink small outline package; 16 leads; body width 4.4 mm	SOT403-1

4.1 Ordering options

Table 2. Ordering options

Type number	Orderable part number	Package	Packing method	Minimum order quantity	Temperature range
PCA9670BS	PCA9670BS,118	HVQFN16	Reel 13" Q1/T1 *standard mark SMD	6000	T _{amb} = -40 °C to +85 °C
PCA9670D	PCA9670D,512	SO16	Standard marking * tube dry pack	1920	T _{amb} = -40 °C to +85 °C
	PCA9670D,518	SO16	Reel 13" Q1/T1 *standard mark SMD dry pack	1000	T _{amb} = -40 °C to +85 °C
PCA9670PW	PCA9670PW,112	TSSOP16	Standard marking * IC's tube - DSC bulk pack	2400	T _{amb} = -40 °C to +85 °C
	PCA9670PW,118	TSSOP16	Reel 13" Q1/T1 *standard mark SMD	2500	T _{amb} = -40 °C to +85 °C

5. Block diagram

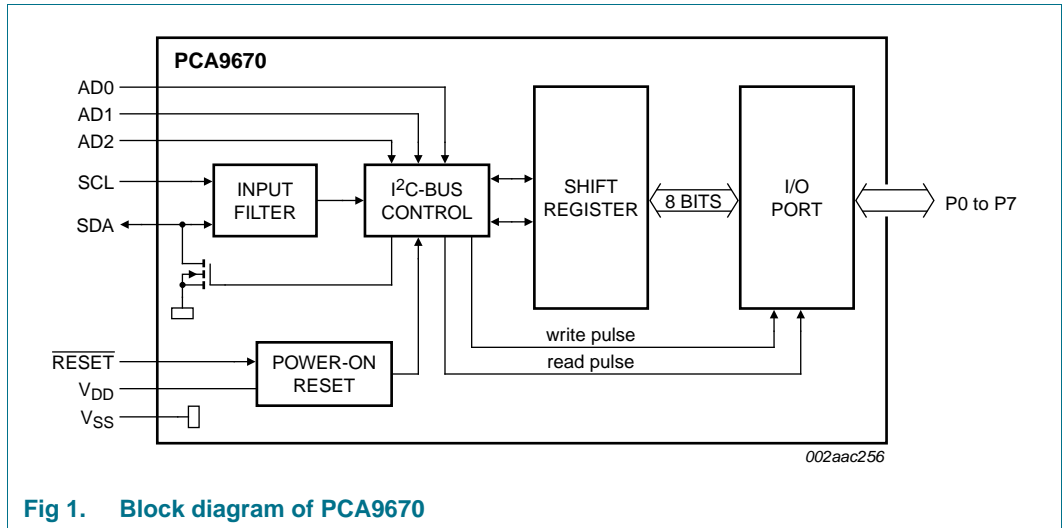

Fig 1. Block diagram of PCA9670

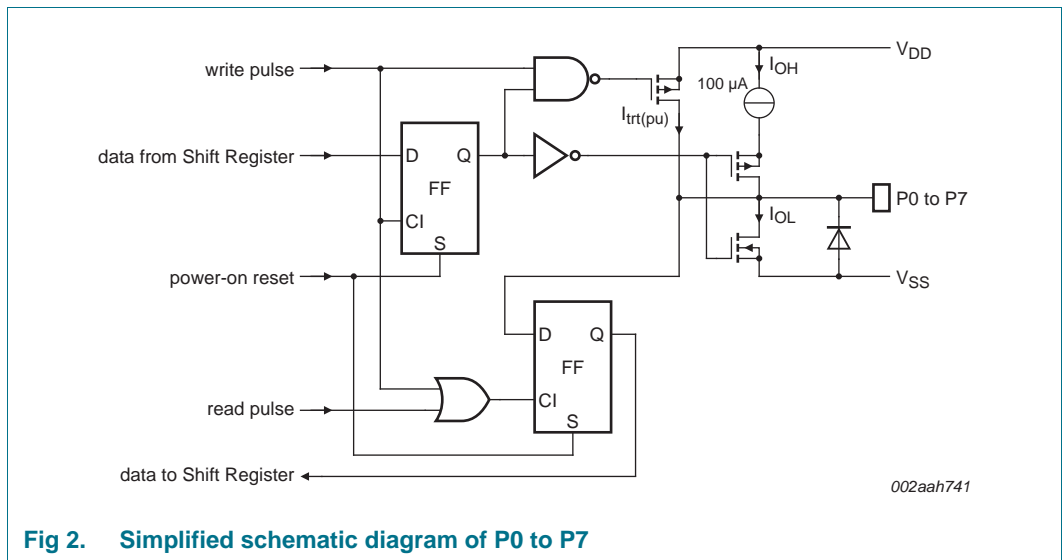
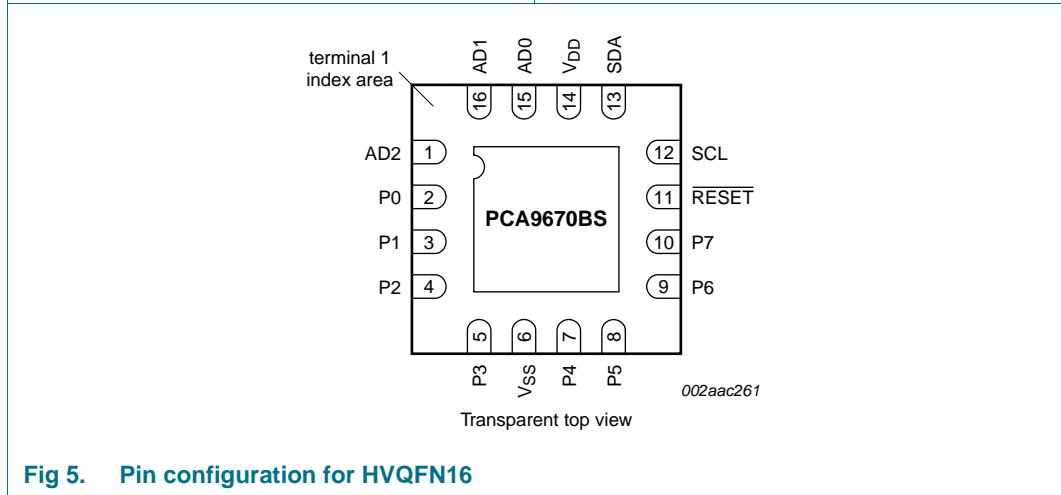
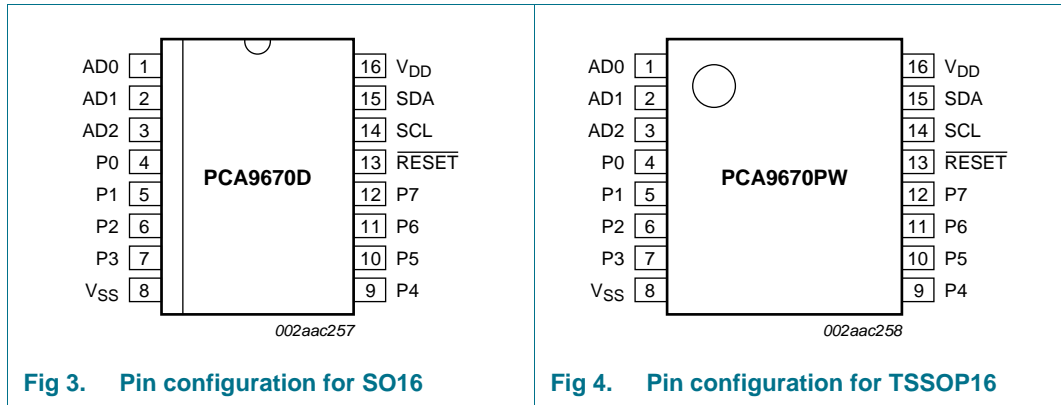

Fig 2. Simplified schematic diagram of P0 to P7

6. Pinning information

6.1 Pinning



6.2 Pin description

Table 3. Pin description

Symbol	Pin		Description
	SO16, TSSOP16	HVQFN16	
AD0	1	15	address input 0
AD1	2	16	address input 1
AD2	3	1	address input 2
P0	4	2	quasi-bidirectional I/O 0
P1	5	3	quasi-bidirectional I/O 1
P2	6	4	quasi-bidirectional I/O 2
P3	7	5	quasi-bidirectional I/O 3
V _{SS}	8	6	supply ground
P4	9	7	quasi-bidirectional I/O 4
P5	10	8	quasi-bidirectional I/O 5
P6	11	9	quasi-bidirectional I/O 6

Table 3. Pin description ...continued

Symbol	Pin		Description
	SO16, TSSOP16	HVQFN16	
P7	12	10	quasi-bidirectional I/O 7
RESET	13	11	reset input (active LOW)
SCL	14	12	serial clock line
SDA	15	13	serial data line
V _{DD}	16	14	supply voltage

[1] HVQFN16 package die supply ground is connected to both the V_{SS} pin and the exposed center pad. The V_{SS} pin must be connected to supply ground for proper device operation. For enhanced thermal, electrical, and board-level performance, the exposed pad needs to be soldered to the board using a corresponding thermal pad on the board, and for proper heat conduction through the board thermal vias need to be incorporated in the PCB in the thermal pad region.

7. Functional description

Refer to [Figure 1 “Block diagram of PCA9670”](#).

7.1 Device address

Following a START condition, the bus master must send the address of the slave it is accessing and the operation it wants to perform (read or write). The address format of the PCA9670 is shown in [Figure 6](#). Slave address pins AD2, AD1, and AD0 are used to choose one of 64 slave addresses. These devices can monitor the change in SDA or SCL in addition to the static levels of V_{DD} or V_{SS} to decode four states allowing a larger address range. To conserve power, no internal pull-up resistors are incorporated on AD2, AD1, or AD0 so they must be externally connected to V_{DD}, V_{SS} directly or through resistors, or to SCL or SDA directly. Address values depending on AD2, AD1, and AD0 can be found in [Table 4 “PCA9670 address map”](#).

Remark: When using the PCA9670, reserved I²C-bus addresses must be used with caution since they can interfere with:

- “reserved for future use” I²C-bus addresses (0000 011, 1111 101, 1111 110, 1111 111)
- slave devices that use the 10-bit addressing scheme (1111 0xx)
- High speed mode (Hs-mode) master code (0000 1xx)

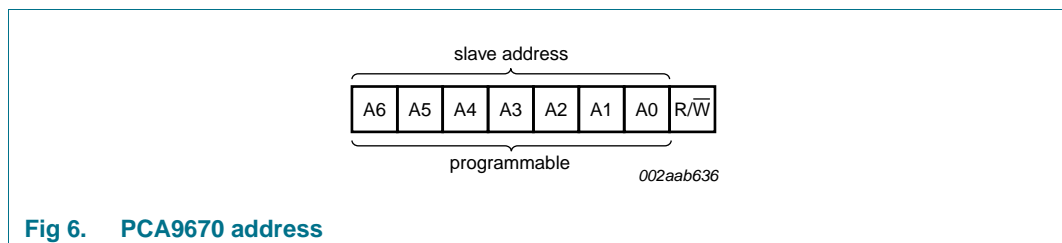

Fig 6. PCA9670 address

The last bit of the first byte defines the operation to be performed. When set to logic 1 a read is selected, while a logic 0 selects a write operation.

When AD2, AD1 and AD0 are held to V_{DD} or V_{SS}, the same address as the PCF8574 or newer PCA8574 is applied.

7.1.1 Address maps

Table 4. PCA9670 address map

Pin connectivity			Address of PCA9670								Address byte value		7-bit hexadecimal address without R/W
AD2	AD1	AD0	A6	A5	A4	A3	A2	A1	A0	R/W	Write	Read	
V _{SS}	SCL	V _{SS}	0	0	1	0	0	0	0	-	20h	21h	10h
V _{SS}	SCL	V _{DD}	0	0	1	0	0	0	1	-	22h	23h	11h
V _{SS}	SDA	V _{SS}	0	0	1	0	0	1	0	-	24h	25h	12h
V _{SS}	SDA	V _{DD}	0	0	1	0	0	1	1	-	26h	27h	13h
V _{DD}	SCL	V _{SS}	0	0	1	0	1	0	0	-	28h	29h	14h
V _{DD}	SCL	V _{DD}	0	0	1	0	1	0	1	-	2Ah	2Bh	15h
V _{DD}	SDA	V _{SS}	0	0	1	0	1	1	0	-	2Ch	2Dh	16h
V _{DD}	SDA	V _{DD}	0	0	1	0	1	1	1	-	2Eh	2Fh	17h
V _{SS}	SCL	SCL	0	0	1	1	0	0	0	-	30h	31h	18h
V _{SS}	SCL	SDA	0	0	1	1	0	0	1	-	32h	33h	19h
V _{SS}	SDA	SCL	0	0	1	1	0	1	0	-	34h	35h	1Ah
V _{SS}	SDA	SDA	0	0	1	1	0	1	1	-	36h	37h	1Bh
V _{DD}	SCL	SCL	0	0	1	1	1	0	0	-	38h	39h	1Ch
V _{DD}	SCL	SDA	0	0	1	1	1	0	1	-	3Ah	3Bh	1Dh
V _{DD}	SDA	SCL	0	0	1	1	1	1	0	-	3Ch	3Dh	1Eh
V _{DD}	SDA	SDA	0	0	1	1	1	1	1	-	3Eh	3Fh	1Fh
V _{SS}	V _{SS}	V _{SS}	0	1	0	0	0	0	0	-	40h	41h	20h
V _{SS}	V _{SS}	V _{DD}	0	1	0	0	0	0	1	-	42h	43h	21h
V _{SS}	V _{DD}	V _{SS}	0	1	0	0	0	1	0	-	44h	45h	22h
V _{SS}	V _{DD}	V _{DD}	0	1	0	0	0	1	1	-	46h	47h	23h
V _{DD}	V _{SS}	V _{SS}	0	1	0	0	1	0	0	-	48h	49h	24h
V _{DD}	V _{SS}	V _{DD}	0	1	0	0	1	0	1	-	4Ah	4Bh	25h
V _{DD}	V _{DD}	V _{SS}	0	1	0	0	1	1	0	-	4Ch	4Dh	26h
V _{DD}	V _{DD}	V _{DD}	0	1	0	0	1	1	1	-	4Eh	4Fh	27h
V _{SS}	V _{SS}	SCL	0	1	0	1	0	0	0	-	50h	51h	28h
V _{SS}	V _{SS}	SDA	0	1	0	1	0	0	1	-	52h	53h	29h
V _{SS}	V _{DD}	SCL	0	1	0	1	0	1	0	-	54h	55h	2Ah
V _{SS}	V _{DD}	SDA	0	1	0	1	0	1	1	-	56h	57h	2Bh
V _{DD}	V _{SS}	SCL	0	1	0	1	1	0	0	-	58h	59h	2Ch
V _{DD}	V _{SS}	SDA	0	1	0	1	1	0	1	-	5Ah	5Bh	2Dh
V _{DD}	V _{DD}	SCL	0	1	0	1	1	1	0	-	5Ch	5Dh	2Eh
V _{DD}	V _{DD}	SDA	0	1	0	1	1	1	1	-	5Eh	5Fh	2Fh

Table 4. PCA9670 address map ...continued

Pin connectivity			Address of PCA9670								Address byte value		7-bit hexadecimal address without R/W
AD2	AD1	AD0	A6	A5	A4	A3	A2	A1	A0	R/W	Write	Read	
SCL	SCL	V _{SS}	1	0	1	0	0	0	0	-	A0h	A1h	50h
SCL	SCL	V _{DD}	1	0	1	0	0	0	1	-	A2h	A3h	51h
SCL	SDA	V _{SS}	1	0	1	0	0	1	0	-	A4h	A5h	52h
SCL	SDA	V _{DD}	1	0	1	0	0	1	1	-	A6h	A7h	53h
SDA	SCL	V _{SS}	1	0	1	0	1	0	0	-	A8h	A9h	54h
SDA	SCL	V _{DD}	1	0	1	0	1	0	1	-	AAh	ABh	55h
SDA	SDA	V _{SS}	1	0	1	0	1	1	0	-	ACH	ADh	56h
SDA	SDA	V _{DD}	1	0	1	0	1	1	1	-	A Eh	A Fh	57h
SCL	SCL	SCL	1	0	1	1	0	0	0	-	B0h	B1h	58h
SCL	SCL	SDA	1	0	1	1	0	0	1	-	B2h	B3h	59h
SCL	SDA	SCL	1	0	1	1	0	1	0	-	B4h	B5h	5Ah
SCL	SDA	SDA	1	0	1	1	0	1	1	-	B6h	B7h	5Bh
SDA	SCL	SCL	1	0	1	1	1	0	0	-	B8h	B9h	5Ch
SDA	SCL	SDA	1	0	1	1	1	0	1	-	BAh	BBh	5Dh
SDA	SDA	SCL	1	0	1	1	1	1	0	-	BCh	BDh	5Eh
SDA	SDA	SDA	1	0	1	1	1	1	1	-	BEh	BFh	5Fh
SCL	V _{SS}	V _{SS}	1	1	0	0	0	0	0	-	C0h	C1h	60h
SCL	V _{SS}	V _{DD}	1	1	0	0	0	0	1	-	C2h	C3h	61h
SCL	V _{DD}	V _{SS}	1	1	0	0	0	1	0	-	C4h	C5h	62h
SCL	V _{DD}	V _{DD}	1	1	0	0	0	1	1	-	C6h	C7h	63h
SDA	V _{SS}	V _{SS}	1	1	0	0	1	0	0	-	C8h	C9h	64h
SDA	V _{SS}	V _{DD}	1	1	0	0	1	0	1	-	CAh	CBh	65h
SDA	V _{DD}	V _{SS}	1	1	0	0	1	1	0	-	CCh	CDh	66h
SDA	V _{DD}	V _{DD}	1	1	0	0	1	1	1	-	CEh	CFh	67h
SCL	V _{SS}	SCL	1	1	1	0	0	0	0	-	E0h	E1h	70h
SCL	V _{SS}	SDA	1	1	1	0	0	0	1	-	E2h	E3h	71h
SCL	V _{DD}	SCL	1	1	1	0	0	1	0	-	E4h	E5h	72h
SCL	V _{DD}	SDA	1	1	1	0	0	1	1	-	E6h	E7h	73h
SDA	V _{SS}	SCL	1	1	1	0	1	0	0	-	E8h	E9h	74h
SDA	V _{SS}	SDA	1	1	1	0	1	0	1	-	EAh	EBh	75h
SDA	V _{DD}	SCL	1	1	1	0	1	1	0	-	ECh	EDh	76h
SDA	V _{DD}	SDA	1	1	1	0	1	1	1	-	E Eh	E Fh	77h

7.2 Software Reset Call, and device ID addresses

Two other different addresses can be sent to the PCA9670.

- General Call address: allows resetting the PCA9670 through the I²C-bus upon reception of the right I²C-bus sequence. See [Section 7.2.1 “Software Reset”](#) for more information.
- Device ID address: allows reading ID information from the device (manufacturer, part identification, revision). See [Section 7.2.2 “Device ID \(PCA9670 ID field\)”](#) for more information.

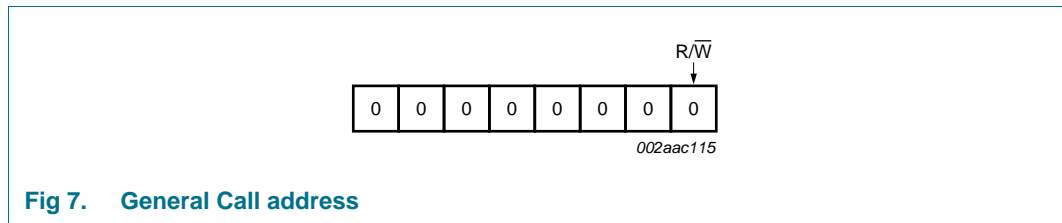

Fig 7. General Call address

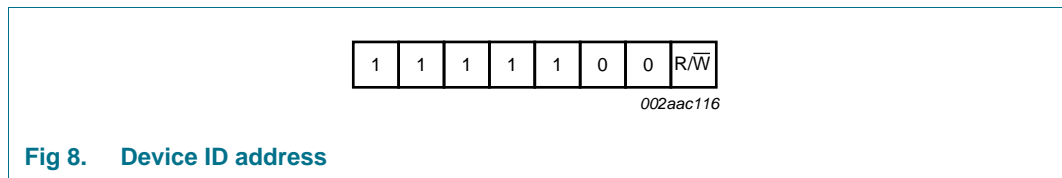

Fig 8. Device ID address

7.2.1 Software Reset

The Software Reset Call allows all the devices in the I²C-bus to be reset to the power-up state value through a specific formatted I²C-bus command. To be performed correctly, it implies that the I²C-bus is functional and that there is no device hanging the bus.

The Software Reset sequence is defined as following:

1. A START command is sent by the I²C-bus master.
2. The reserved General Call I²C-bus address '0000 000' with the $\overline{R/W}$ bit set to 0 (write) is sent by the I²C-bus master.
3. The PCA9670 device(s) acknowledge(s) after seeing the General Call address '0000 0000' (00h) only. If the $\overline{R/W}$ bit is set to 1 (read), no acknowledge is returned to the I²C-bus master.
4. Once the General Call address has been sent and acknowledged, the master sends 1 byte. The value of the byte must be equal to 06h.
 - a. The PCA9670 acknowledges this value only. If the byte is not equal to 06h, the PCA9670 does not acknowledge it.

If more than 1 byte of data is sent, the PCA9670 does not acknowledge any more.

5. Once the right byte has been sent and correctly acknowledged, the master sends a STOP command to end the Software Reset sequence: the PCA9670 then resets to the default value (power-up value) and is ready to be addressed again within the specified bus free time. If the master sends a Repeated START instead, no reset is performed.

The I²C-bus master must interpret a non-acknowledge from the PCA9670 (at any time) as a 'Software Reset Abort'. The PCA9670 does not initiate a reset of its registers.

The unique sequence that initiates a Software Reset is described in [Figure 9](#).

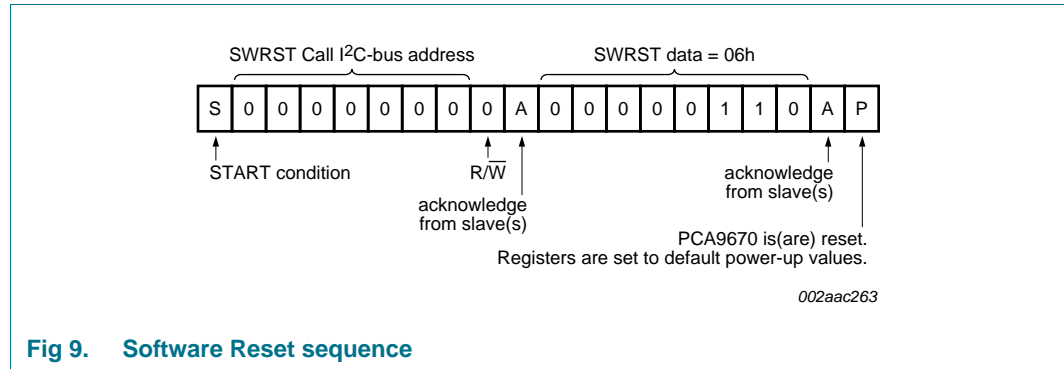

Fig 9. Software Reset sequence

Simple code for Software Reset:

```
<S> <00h> <ACK> <06h> <ACK> <P>
```

7.2.2 Device ID (PCA9670 ID field)

The Device ID field is a 3-byte read-only (24 bits) word giving the following information:

- 12 bits with the manufacturer name, unique per manufacturer (for example, NXP).
- 9 bits with the part identification, assigned by manufacturer.
- 3 bits with the die revision, assigned by manufacturer (for example, Rev X).

The Device ID is read-only, hardwired in the device and can be accessed as follows:

1. START command
2. The master sends the Reserved Device ID I²C-bus address '1111 100' with the R/W bit set to 0 (write).
3. The master sends the I²C-bus slave address of the slave device it needs to identify. The LSB is a 'Don't care' value. Only one device must acknowledge this byte (the one that has the I²C-bus slave address).
4. The master sends a Re-START command.

Remark: A STOP command followed by a START command will reset the slave state machine and the Device ID read cannot be performed.

Remark: A STOP command or a Re-START command followed by an access to another slave device will reset the slave state machine and the Device ID read cannot be performed.

5. The master sends the Reserved Device ID I²C-bus address '1111 100' with the R/W bit set to 1 (read).
6. The device ID read can be done, starting with the 12 manufacturer bits (first byte + 4 MSB of the second byte), followed by the 9 part identification bits and then the 3 die revision bits (3 LSB of the third byte).
7. The master ends the reading sequence by NACKing the last byte, thus resetting the slave device state machine and allowing the master to send the STOP command.

Remark: The reading of the Device ID can be stopped anytime by sending a NACK command.

Remark: If the master continues to ACK the bytes after the third byte, the PCA9670 rolls back to the first byte and keeps sending the Device ID sequence until a NACK has been detected.

For the PCA9670, the Device ID is as shown in [Figure 10](#).

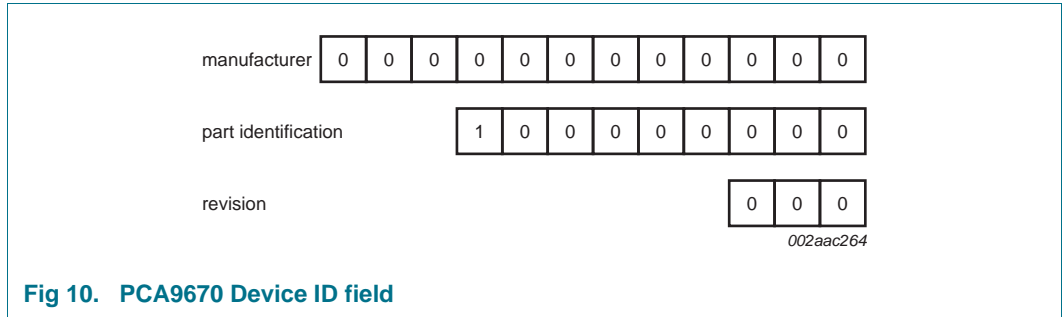
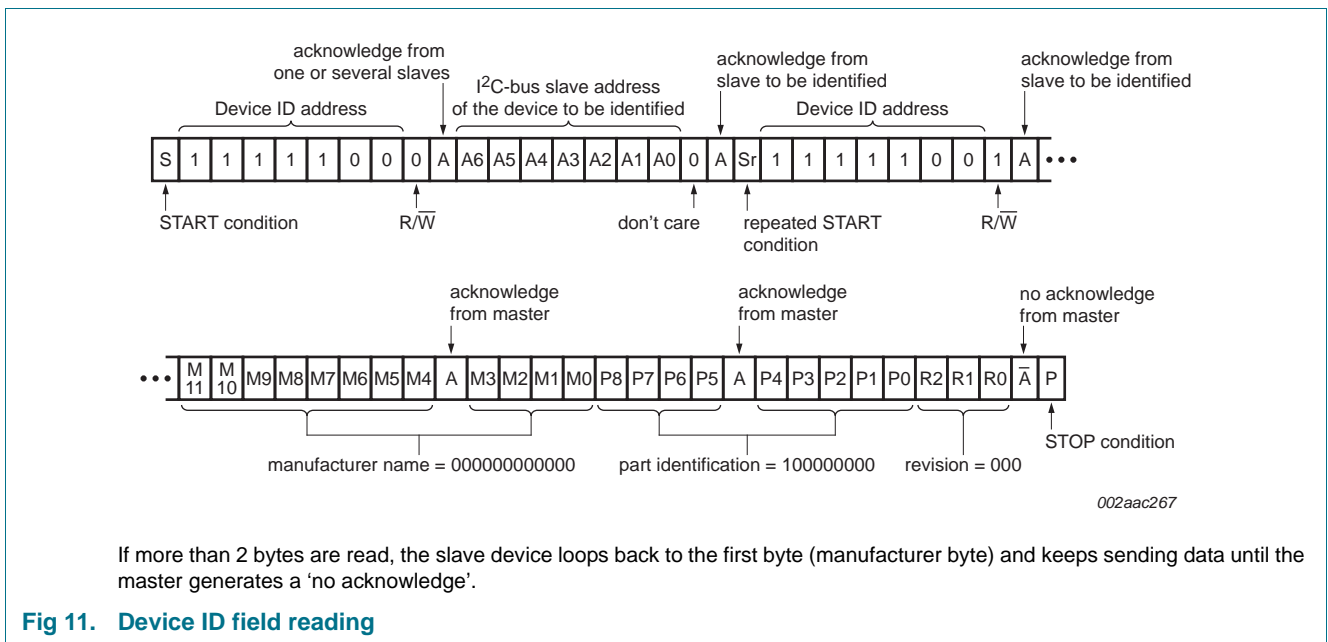

Fig 10. PCA9670 Device ID field



If more than 2 bytes are read, the slave device loops back to the first byte (manufacturer byte) and keeps sending data until the master generates a 'no acknowledge'.

Fig 11. Device ID field reading

Simple code for reading Device ID:

```
<S> <F8h> <ACK> <slave address> <ACK> <SR> <F9h> <ACK> <DATA1>
<ACK> <DATA2> <ACK> <DATA3> <NACK> <P>
```

8. I/O programming

8.1 Quasi-bidirectional I/O architecture

A quasi-bidirectional I/O is an input or output port without using a direction control register. Whenever the master reads the register, the value returned to master depends on the actual voltage or status of the pin. At power-on, all the ports are HIGH with a weak 100 μ A internal pull-up to V_{DD} but can be driven LOW by an internal transistor, or an external signal. The I/O ports are entirely independent of each other but each I/O octal is controlled by the same read or write data byte.

Advantages of the quasi-bidirectional I/O over totem pole I/O include:

- Better for driving LEDs since the p-channel (transistor to V_{DD}) is small, which saves die size and therefore cost. LED drive only requires an internal transistor to ground, while the LED is connected to V_{DD} through a current-limiting resistor. Totem pole I/O have both an n-channel and p-channel transistors, which allow solid HIGH and LOW output levels without a pull-up resistor — good for logic levels.
- Simpler architecture — only a single register and the I/O can be both input and output at the same time. Totem pole I/O have a direction register which specifies the port pin direction and it is always in that configuration unless the direction is explicitly changed.
- Does not require a command byte. The simplicity of one register (no need for the pointer register or technically, the command byte) is an advantage in some embedded systems where every byte counts because of memory or bandwidth limitations.

There is only one register to control four possibilities of the port pin: Input HIGH, input LOW, output HIGH or output LOW.

Input HIGH: The master needs to write 1 to the register to set the port as an input mode if the device is not in the default power-on condition. The master reads the register to check the input status. If the external source pulls the port pin up to V_{DD} or drives logic 1, then the master will read the value of 1.

Input LOW: The master needs to write 1 to the register to set the port to input mode if the device is not in the default power-on condition. The master reads the register to check the input status. If the external source pulls the port pin down to V_{SS} or drives logic 0, which sinks the weak 100 μ A current source, then the master will read the value of 0.

Output HIGH: The master writes 1 to the register. There is an additional 'accelerator' or strong pull-up current when the master sets the port HIGH. The additional strong pull-up is only active during the HIGH time of the acknowledge clock cycle. This accelerator current helps the port's 100 μ A current source make a faster rising edge into a heavily loaded output, but only at the start of the acknowledge clock cycle to avoid bus contention if an external signal is pulling the port LOW to V_{SS} /driving the port with logic 0 at the same time. After the half clock cycle there is only the 100 μ A current source to hold the port HIGH.

Output LOW: The master writes 0 to the register. There is a strong current sink transistor that holds the port pin LOW. A large current may flow into the port, which could potentially damage the part if the master writes a 0 to the register and an external source is pulling the port HIGH at the same time.

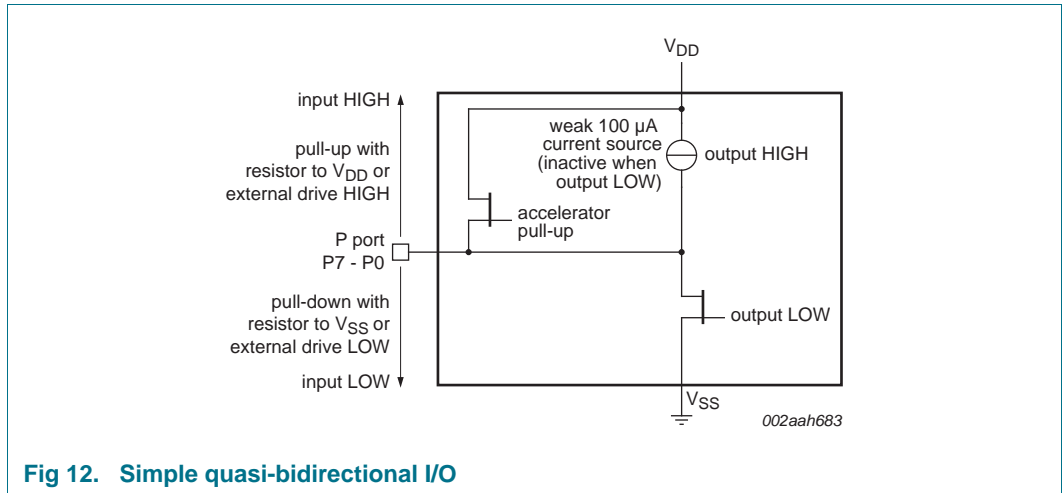

8.2 Writing to the port (Output mode)

The master (microcontroller) sends the START condition and slave address, setting the last bit of the address byte to logic 0 for the write mode. The PCA9670 acknowledges and the master then sends the data byte for P7 to P0 to the port register. As the clock line goes HIGH, the 8-bit data is presented on the port lines after it has been acknowledged by the PCA9670. If a LOW is written, the strong pull-down turns on and stays on. If a HIGH is written, the strong pull-up turns on for 1/2 of the clock cycle, then the line is held HIGH by the weak current source. The master can then send a STOP condition or continuing sending data. The number of data bytes that can be sent successively is not limited and the previous data is overwritten every time a data byte has been sent and acknowledged.

Ensure a logic 1 is written for any port that is being used as an input to ensure the strong external pull-down is turned off.

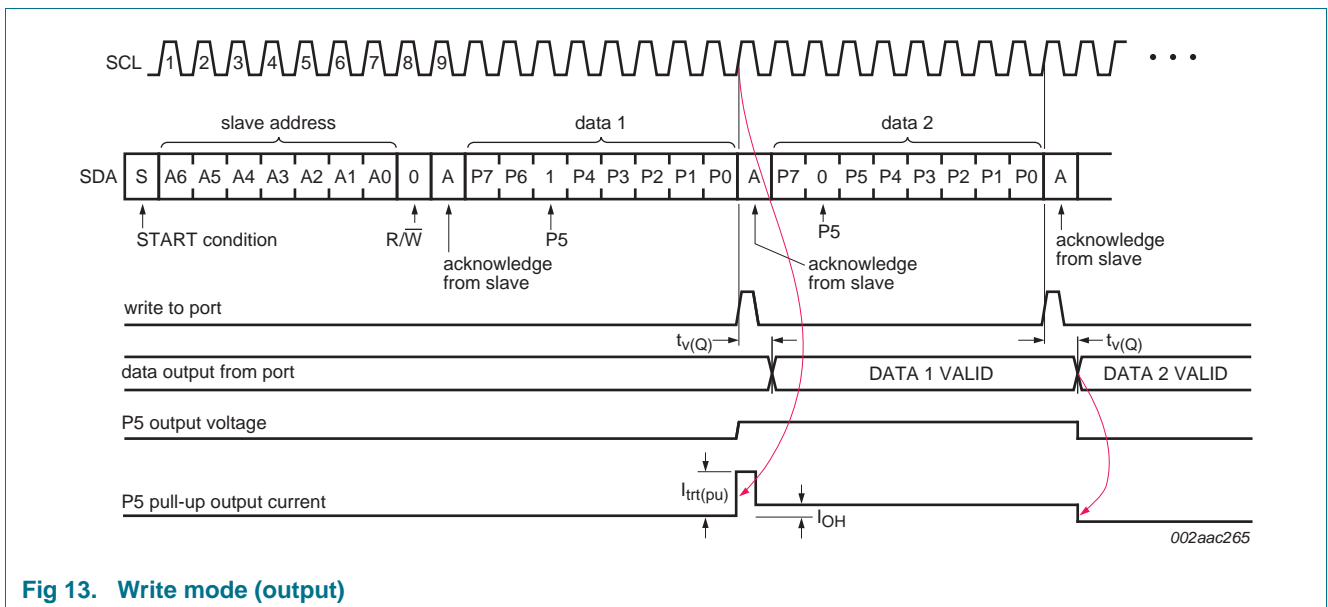

8.3 Reading from a port (Input mode)

The port must have been previously written to logic 1, which is the condition after power-on reset or hardware reset or software reset. To enter the Read mode the master (microcontroller) addresses the slave device and sets the last bit of the address byte to logic 1 (address byte read). The slave will acknowledge and then send the data byte to the master. The master will NACK and then send the STOP condition or ACK and read the input register again.

The read of any pin being used as an output will indicate HIGH or LOW depending on the actual state of the input pin.

If the data on the input port changes faster than the master can read, this data may be lost. The DATA 2 and DATA 3 are lost because these data did not meet the set-up time and hold time (see Figure 14).

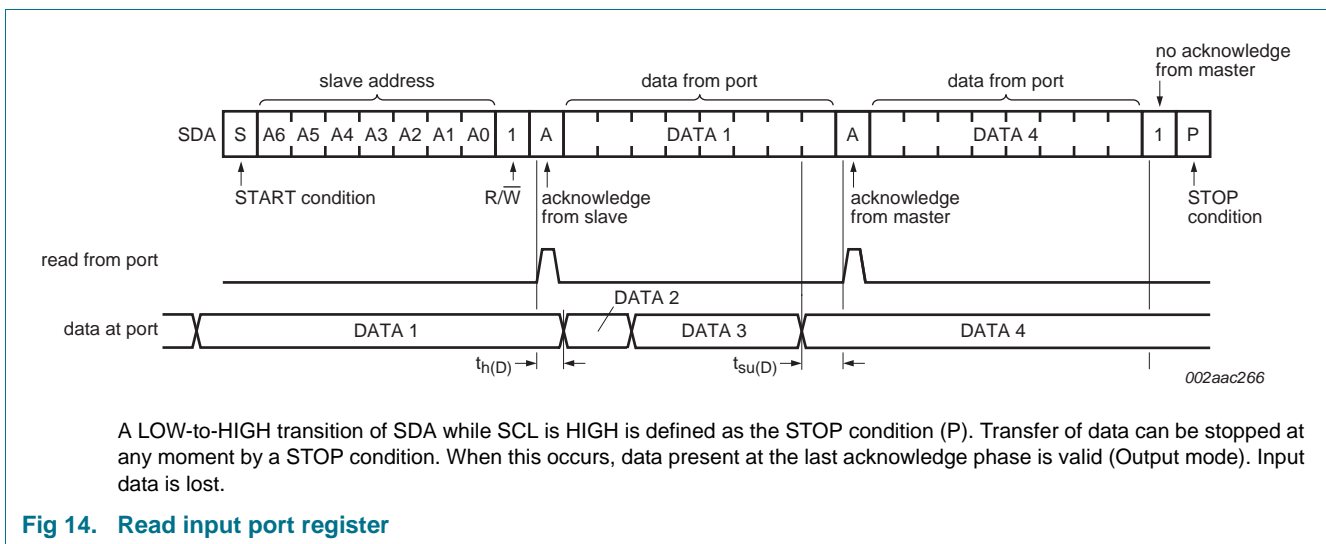

Fig 14. Read input port register

8.4 Power-on reset

When power is applied to V_{DD} , an internal Power-On Reset (POR) holds the PCA9670 in a reset condition until V_{DD} has reached V_{POR} . At that point, the reset condition is released and the PCA9670 registers and I²C-bus/SMBus state machine will initialize to their default states of all I/Os to inputs with weak current source to V_{DD} . Thereafter V_{DD} must be lowered below V_{POR} and back up to the operation voltage for power-on reset cycle.

8.5 RESET input

A reset can be accomplished by holding the \overline{RESET} pin LOW for a minimum of $t_{w(rst)}$. The PCA9670 registers and I²C-bus state machine will be held in their default state until the \overline{RESET} input is once again HIGH. This \overline{RESET} input pin requires a pull-up resistor to V_{DD} if no active connection is used.

9. Characteristics of the I²C-bus

The I²C-bus is for 2-way, 2-line communication between different ICs or modules. The two lines are a serial data line (SDA) and a serial clock line (SCL). Both lines must be connected to a positive supply via a pull-up resistor when connected to the output stages of a device. Data transfer may be initiated only when the bus is not busy.

9.1 Bit transfer

One data bit is transferred during each clock pulse. The data on the SDA line must remain stable during the HIGH period of the clock pulse as changes in the data line at this time will be interpreted as control signals (see [Figure 15](#)).

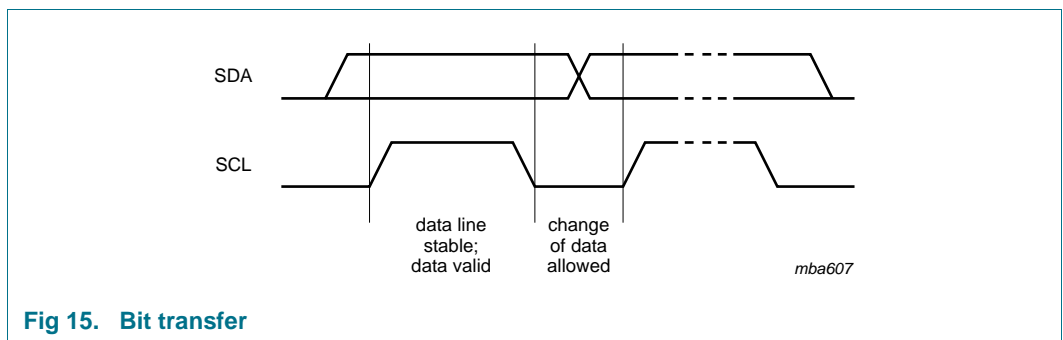

Fig 15. Bit transfer

9.1.1 START and STOP conditions

Both data and clock lines remain HIGH when the bus is not busy. A HIGH-to-LOW transition of the data line while the clock is HIGH is defined as the START condition (S). A LOW-to-HIGH transition of the data line while the clock is HIGH is defined as the STOP condition (P) (see [Figure 16](#)).

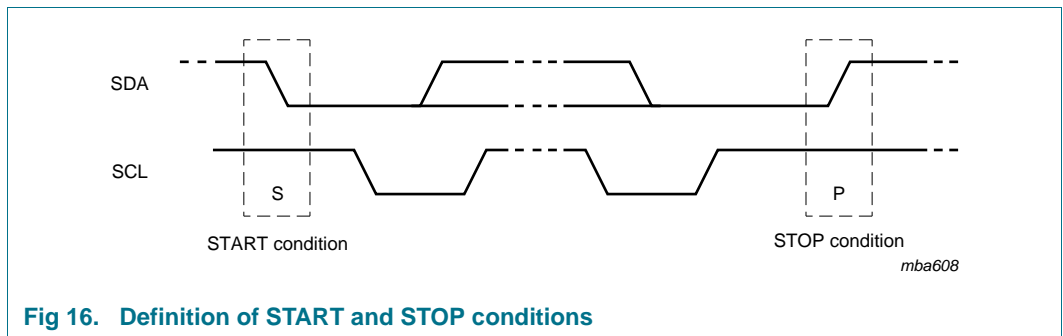

Fig 16. Definition of START and STOP conditions

9.2 System configuration

A device generating a message is a 'transmitter'; a device receiving is the 'receiver'. The device that controls the message is the 'master' and the devices which are controlled by the master are the 'slaves' (see [Figure 17](#)).

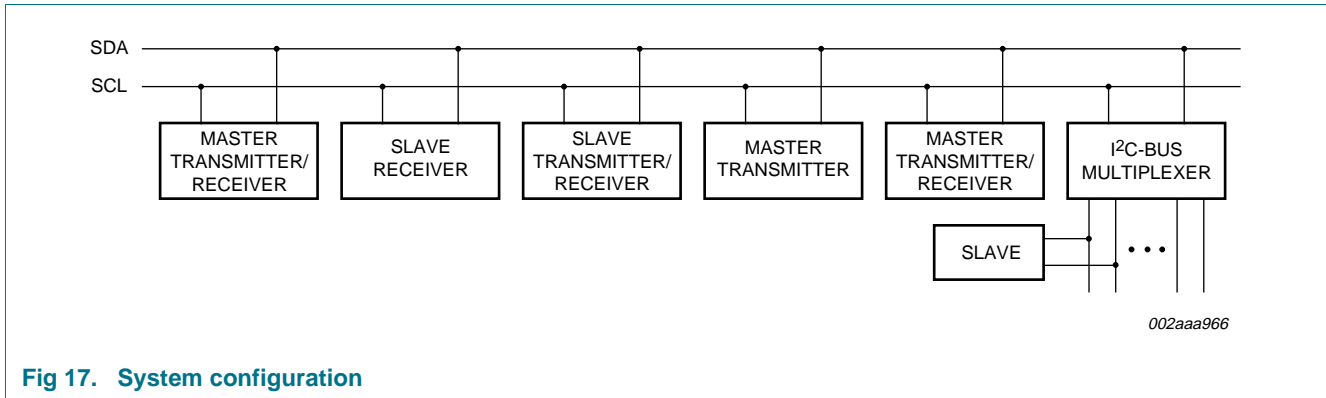

Fig 17. System configuration

9.3 Acknowledge

The number of data bytes transferred between the START and the STOP conditions from transmitter to receiver is not limited. Each byte of eight bits is followed by one acknowledge bit (see [Figure 18](#)). The acknowledge bit is an active LOW level (generated by the receiving device) that indicates to the transmitter that the data transfer was successful.

A slave receiver which is addressed must generate an acknowledge after the reception of each byte. Also a master must generate an acknowledge after the reception of each byte that has been clocked out of the slave transmitter. The device that wants to issue an acknowledge bit has to pull down the SDA line during the acknowledge clock pulse, so that the SDA line is stable LOW during the HIGH period of the acknowledge bit related clock pulse; set-up and hold times must be taken into account.

A master receiver must signal an end of data to the transmitter by not generating an acknowledge on the last byte that has been clocked out of the slave. In this event, the transmitter must leave the data line HIGH to enable the master to generate a STOP condition.

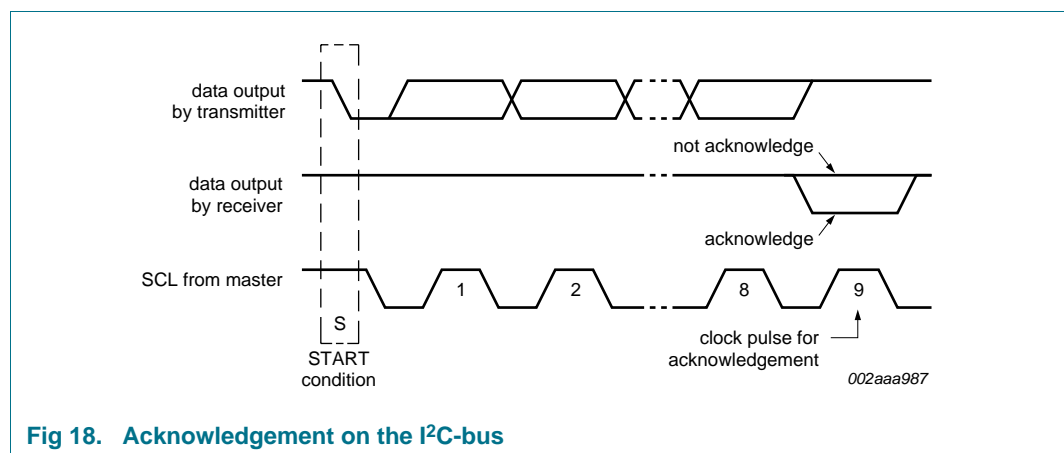

Fig 18. Acknowledgement on the I²C-bus

10. Application design-in information

10.1 Bidirectional I/O expander applications

In the 8-bit I/O expander application shown in [Figure 19](#), P0 and P1 are inputs, and P2 to P7 are outputs. When used in this configuration, during a write, **the input (P0 and P1) must be written as HIGH so the external devices fully control the input ports**. The desired HIGH or LOW logic levels may be written to the I/Os used as outputs (P2 to P7). If 10 µA internal output HIGH is not enough current source, the port needs external pull-up resistor. During a read, the logic levels of the external devices driving the input ports (P0 and P1) and the previous written logic level to the output ports (P2 to P7) will be read.

The GPIO also has a reset line ($\overline{\text{RESET}}$) that can be connected to an output pin of the microprocessor. Since the device does not have an interrupt output, changes of the I/Os can be monitored by reading the input register. If both a $\overline{\text{RESET}}$ and $\overline{\text{INT}}$ are needed, use the PCA9672.

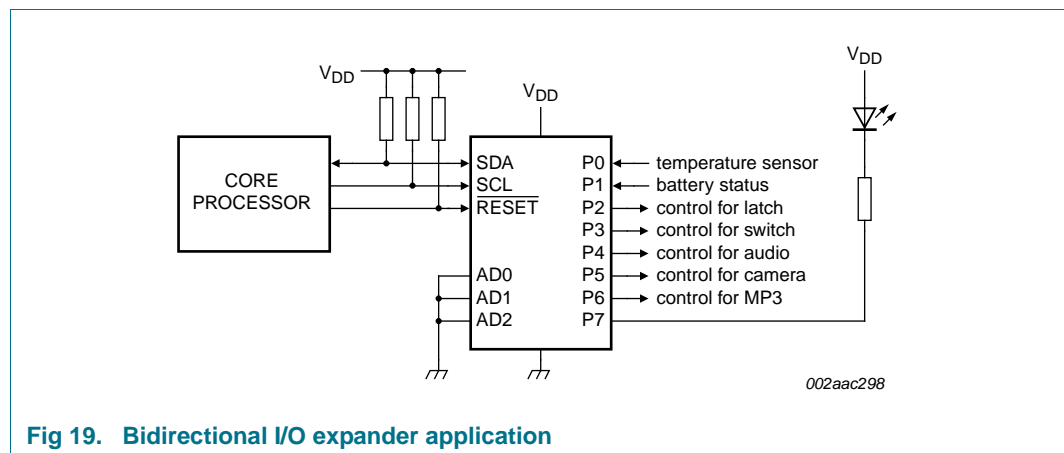

Fig 19. Bidirectional I/O expander application

10.2 How to read and write to I/O expander (example)

In the application example of PCA9670 shown in [Figure 19](#), the microcontroller wants to control the P3 switch ON and the P7 LED ON when the temperature sensor P0 changes.

1. When the system power on:

Core Processor needs to issue an initial command to set P0 and P1 as inputs and P[7:2] as outputs with value 1010 00 (LED off, MP3 off, camera on, audio off, switch off and latch off).

2. Operation:

When the temperature changes above the threshold, the temperature sensor signal will toggle from HIGH to LOW. The INT will be activated and notifies the 'core processor' that there have been changes on the input pins. Read the input register. If P0 = 0 (temperature sensor has changed), then turn on LED and turn on switch.

3. Software code:

```
//System Power on
// write to PCA9670 with data 1010 0011b to set P[7:2] outputs and P[1:0] inputs
<S> <0100 0000> <ACK> <1010 0011> <ACK> <P> //Initial setting for PCA9670
while (1) //Looping look for P0 = 0
```

```

{
  <S> <0100 0001> <ACK> <1010 0010> <NACK> <P> //Read PCA9670 data
  If (P0 == 0) //Temperature sensor activated
  {
    // write to PCA9670 with data 0010 1011b to turn on LED (P7), on Switch (P3)
    and keep P[1:0] as input ports.
    <S> <0100 0000> <ACK> <0010 1011> <ACK> <P> // Write to PCA9670
    Exit the loop;
  }
}
    
```

10.3 High current-drive load applications

The GPIO has a minimum guaranteed sinking current of 25 mA per bit at 5.5 V. In applications requiring additional drive, two port pins may be connected together to sink up to 50 mA current. Both bits must then always be turned on or off together. Up to 8 pins can be connected together to drive 200 mA, which is the device recommended total limit. Each pin needs its own limiting resistor as shown in [Figure 20](#) to prevent damage to the device should all ports not be turned on at the same time.

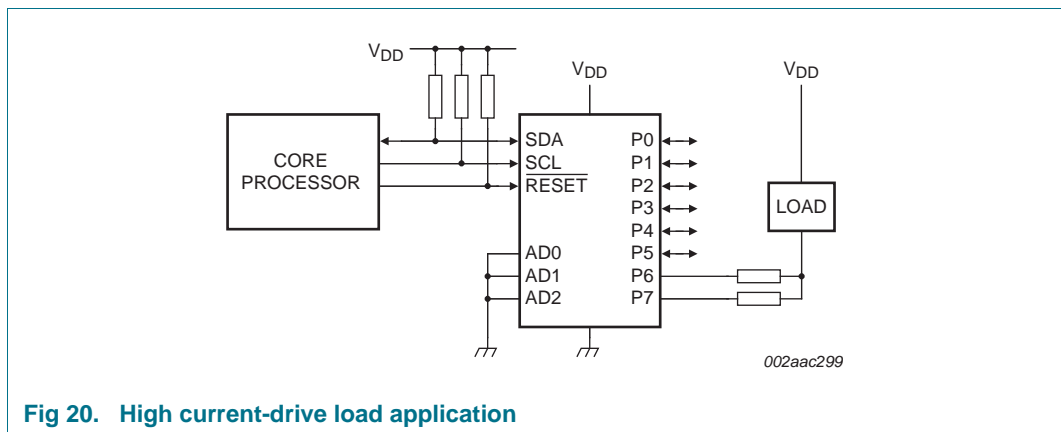

Fig 20. High current-drive load application

10.4 Migration path

NXP offers new, more capable drop-in replacements for the PCA9670 in newer space-saving packages.

Table 5. PCA9670 migration path

Type number	I ² C-bus frequency	Voltage range	Number of addresses per device	Interrupt	Reset	Total package sink current
PCF8574/74A	100 kHz	2.5 V to 6 V	8	yes	no	80 mA
PCA8574/74A	400 kHz	2.3 V to 5.5 V	8	yes	no	200 mA
PCA9674/74A	1 MHz Fm+	2.3 V to 5.5 V	64	yes	no	200 mA
PCA9670	1 MHz Fm+	2.3 V to 5.5 V	64	no	yes	200 mA
PCA9672	1 MHz Fm+	2.3 V to 5.5 V	16	yes	yes	200 mA

PCA9670 replaces the interrupt output of the PCA9674 with hardware reset input to retain the maximum number of addresses. PCA9672 replaces address A2 of the PCA9674 with hardware reset input to retain the interrupt, but limit the number of addresses.

11. Limiting values

Table 6. Limiting values

In accordance with the Absolute Maximum Rating System (IEC 60134).

Symbol	Parameter	Conditions	Min	Max	Unit
V _{DD}	supply voltage		-0.5	+6	V
I _{DD}	supply current		-	±100	mA
I _{SS}	ground supply current		-	±400	mA
V _I	input voltage		V _{SS} - 0.5	5.5	V
I _I	input current		-	±20	mA
I _O	output current	[1]	-	±50	mA
P _{tot}	total power dissipation		-	400	mW
P/out	power dissipation per output		-	100	mW
T _{j(max)}	maximum junction temperature		-	125	°C
T _{stg}	storage temperature		-65	+150	°C
T _{amb}	ambient temperature	operating	-40	+85	°C

[1] Total package (maximum) output current is 400 mA.

12. Thermal characteristics

Table 7. Thermal characteristics

Symbol	Parameter	Conditions	Typ	Unit
R _{th(j-a)}	thermal resistance from junction to ambient	SO16 package	115	°C/W
		TSSOP16 package	160	°C/W
		HVQFN16 package	40	°C/W

13. Static characteristics

Table 8. Static characteristics

$V_{DD} = 2.3\text{ V to }5.5\text{ V}$; $V_{SS} = 0\text{ V}$; $T_{amb} = -40\text{ °C to }+85\text{ °C}$; unless otherwise specified.

Symbol	Parameter	Conditions	Min	Typ	Max	Unit
Supplies						
V_{DD}	supply voltage		2.3	-	5.5	V
I_{DD}	supply current	Operating mode; no load; $V_I = V_{DD}$ or V_{SS} ; $f_{SCL} = 1\text{ MHz}$; AD0, AD1, AD2 = static H or L	-	266	500	μA
I_{stb}	standby current	Standby mode; no load; $V_I = V_{DD}$ or V_{SS} ; $f_{SCL} = 0\text{ kHz}$	-	2.5	10	μA
V_{POR}	power-on reset voltage		[1] -	1.8	2.0	V
Input SCL; input/output SDA						
V_{IL}	LOW-level input voltage		-0.5	-	+0.3 V_{DD}	V
V_{IH}	HIGH-level input voltage		0.7 V_{DD}	-	5.5	V
I_{OL}	LOW-level output current	$V_{OL} = 0.4\text{ V}$; $V_{DD} = 2.3\text{ V}$	20	-	-	mA
		$V_{OL} = 0.4\text{ V}$; $V_{DD} = 3.0\text{ V}$	25	-	-	mA
		$V_{OL} = 0.4\text{ V}$; $V_{DD} = 4.5\text{ V}$	30	-	-	mA
I_L	leakage current	$V_I = V_{DD}$ or V_{SS}	-1	-	+1	μA
C_i	input capacitance	$V_I = V_{SS}$	-	4	10	pF
I/Os; P0 to P7						
V_{IL}	LOW-level input voltage		-0.5	-	+0.3 V_{DD}	V
V_{IH}	HIGH-level input voltage		0.7 V_{DD}	-	5.5	V
I_{OL}	LOW-level output current	$V_{OL} = 0.5\text{ V}$; $V_{DD} = 2.3\text{ V}$	[2] 12	27	-	mA
		$V_{OL} = 0.5\text{ V}$; $V_{DD} = 3.0\text{ V}$	[2] 17	35	-	mA
		$V_{OL} = 0.5\text{ V}$; $V_{DD} = 4.5\text{ V}$	[2] 25	41	-	mA
$I_{OL(tot)}$	total LOW-level output current	$V_{OL} = 0.5\text{ V}$; $V_{DD} = 4.5\text{ V}$	[2] -	-	200	mA
I_{OH}	HIGH-level output current	$V_{OH} = V_{SS}$	-30	-250	-300	μA
$I_{trt(pu)}$	transient boosted pull-up current	$V_{OH} = V_{SS}$; see Figure 13	-0.5	-1.0	-	mA
C_i	input capacitance		[3] -	3	10	pF
C_o	output capacitance		[3] -	3	10	pF
Input RESET						
V_{IL}	LOW-level input voltage		-0.5	-	+0.8	V
V_{IH}	HIGH-level input voltage		2	-	5.5	V
I_{LI}	input leakage current		-1	-	+1	μA
C_i	input capacitance		-	3	5	pF
Inputs AD0, AD1, AD2						
V_{IL}	LOW-level input voltage		-0.5	-	+0.3 V_{DD}	V
V_{IH}	HIGH-level input voltage		0.7 V_{DD}	-	5.5	V
I_{LI}	input leakage current		-1	-	+1	μA
C_i	input capacitance		-	3	5	pF

[1] The power-on reset circuit resets the I²C-bus logic with $V_{DD} < V_{POR}$ and set all I/Os to logic 1 (with current source to V_{DD}).

[2] Each bit must be limited to a maximum of 25 mA and the total package limited to 200 mA due to internal busing limits.

[3] The value is not tested, but verified on sampling basis.

14. Dynamic characteristics

Table 9. Dynamic characteristics

$V_{DD} = 2.3\text{ V to }5.5\text{ V}$; $V_{SS} = 0\text{ V}$; $T_{amb} = -40\text{ }^{\circ}\text{C to }+85\text{ }^{\circ}\text{C}$; unless otherwise specified.

Symbol	Parameter	Conditions	Standard mode I ² C-bus		Fast mode I ² C-bus		Fast-mode Plus I ² C-bus		Unit
			Min	Max	Min	Max	Min	Max	
f _{SCL}	SCL clock frequency		0	100	0	400	0	1000	kHz
t _{BUF}	bus free time between a STOP and START condition		4.7	-	1.3	-	0.5	-	μs
t _{HD;STA}	hold time (repeated) START condition		4.0	-	0.6	-	0.26	-	μs
t _{SU;STA}	set-up time for a repeated START condition		4.7	-	0.6	-	0.26	-	μs
t _{SU;STO}	set-up time for STOP condition		4.0	-	0.6	-	0.26	-	μs
t _{HD;DAT}	data hold time		0	-	0	-	0	-	ns
t _{V_D;ACK}	data valid acknowledge time	[1]	0.3	3.45	0.1	0.9	0.05	0.45	μs
t _{V_D;DAT}	data valid time	[2]	300	-	50	-	50	450	ns
t _{SU;DAT}	data set-up time		250	-	100	-	50	-	ns
t _{LOW}	LOW period of the SCL clock		4.7	-	1.3	-	0.5	-	μs
t _{HIGH}	HIGH period of the SCL clock		4.0	-	0.6	-	0.26	-	μs
t _f	fall time of both SDA and SCL signals	[4][5]	-	300	20 + 0.1C _b [3]	300	-	120	ns
t _r	rise time of both SDA and SCL signals		-	1000	20 + 0.1C _b [3]	300	-	120	ns
t _{SP}	pulse width of spikes that must be suppressed by the input filter	[6]	-	50	-	50	-	50	ns

Port timing; C_L ≤ 100 pF (see Figure 14 and Figure 13)

t _{V(Q)}	data output valid time		-	4	-	4	-	4	μs
t _{su(D)}	data input set-up time		0	-	0	-	0	-	μs
t _{h(D)}	data input hold time		4	-	4	-	4	-	μs

Reset timing (see Figure 22)

t _{w(rst)}	reset pulse width		4	-	4	-	4	-	μs
t _{rec(rst)}	reset recovery time		0	-	0	-	0	-	μs
t _{rst}	reset time		100	-	100	-	100	-	μs

[1] t_{V_D;ACK} = time for Acknowledgement signal from SCL LOW to SDA (out) LOW.

[2] t_{V_D;DAT} = minimum time for SDA data out to be valid following SCL LOW.

[3] C_b = total capacitance of one bus line in pF.

- [4] A master device must internally provide a hold time of at least 300 ns for the SDA signal (refer to the V_{IL} of the SCL signal) in order to bridge the undefined region SCL's falling edge.
- [5] The maximum t_f for the SDA and SCL bus lines is specified at 300 ns. The maximum fall time for the SDA output stage t_f is specified at 250 ns. This allows series protection resistors to be connected between the SDA and the SCL pins and the SDA/SCL bus lines without exceeding the maximum specified t_f .
- [6] Input filters on the SDA and SCL inputs suppress noise spikes less than 50 ns.

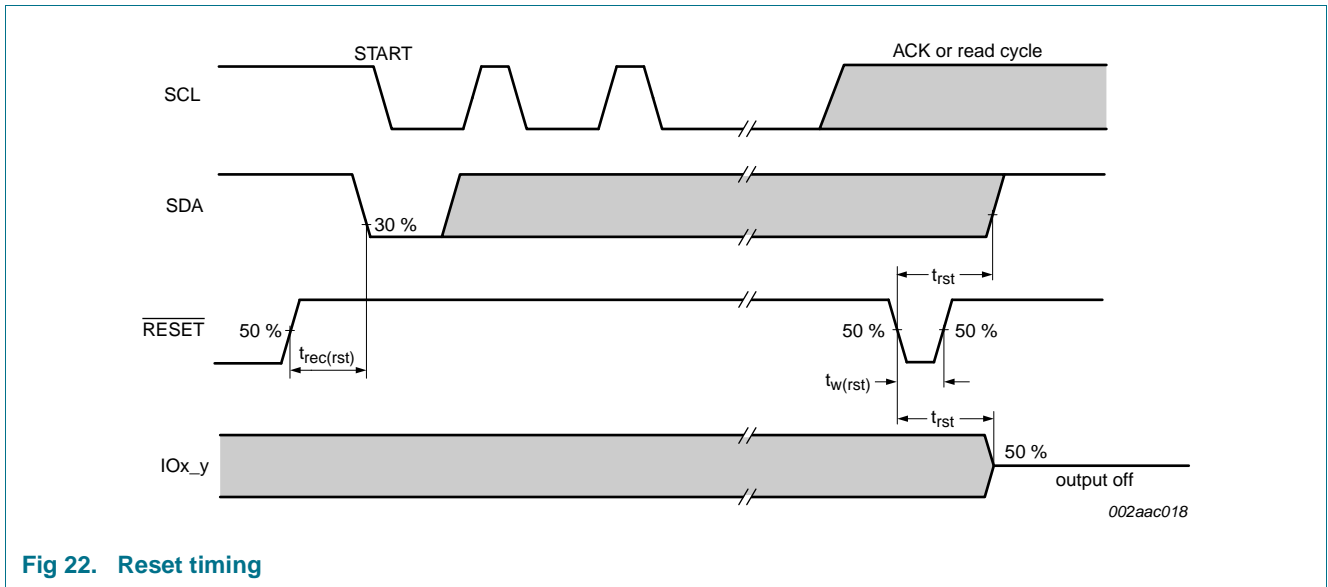
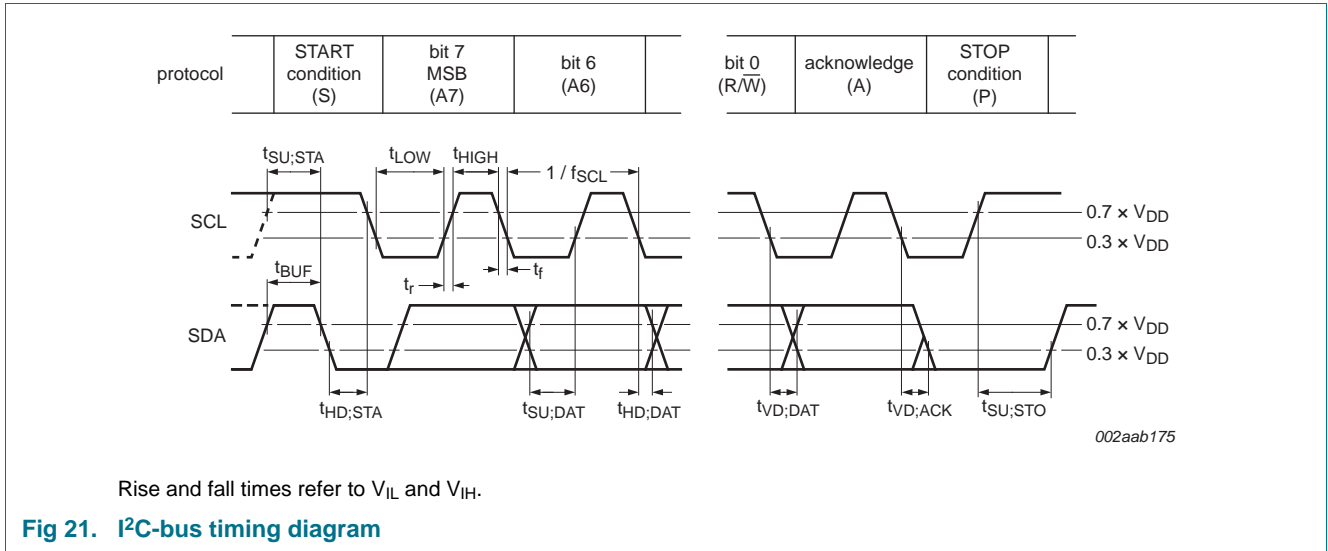

15. Package outline

HVQFN16: plastic thermal enhanced very thin quad flat package; no leads; 16 terminals; body 3 x 3 x 0.85 mm

SOT758-1

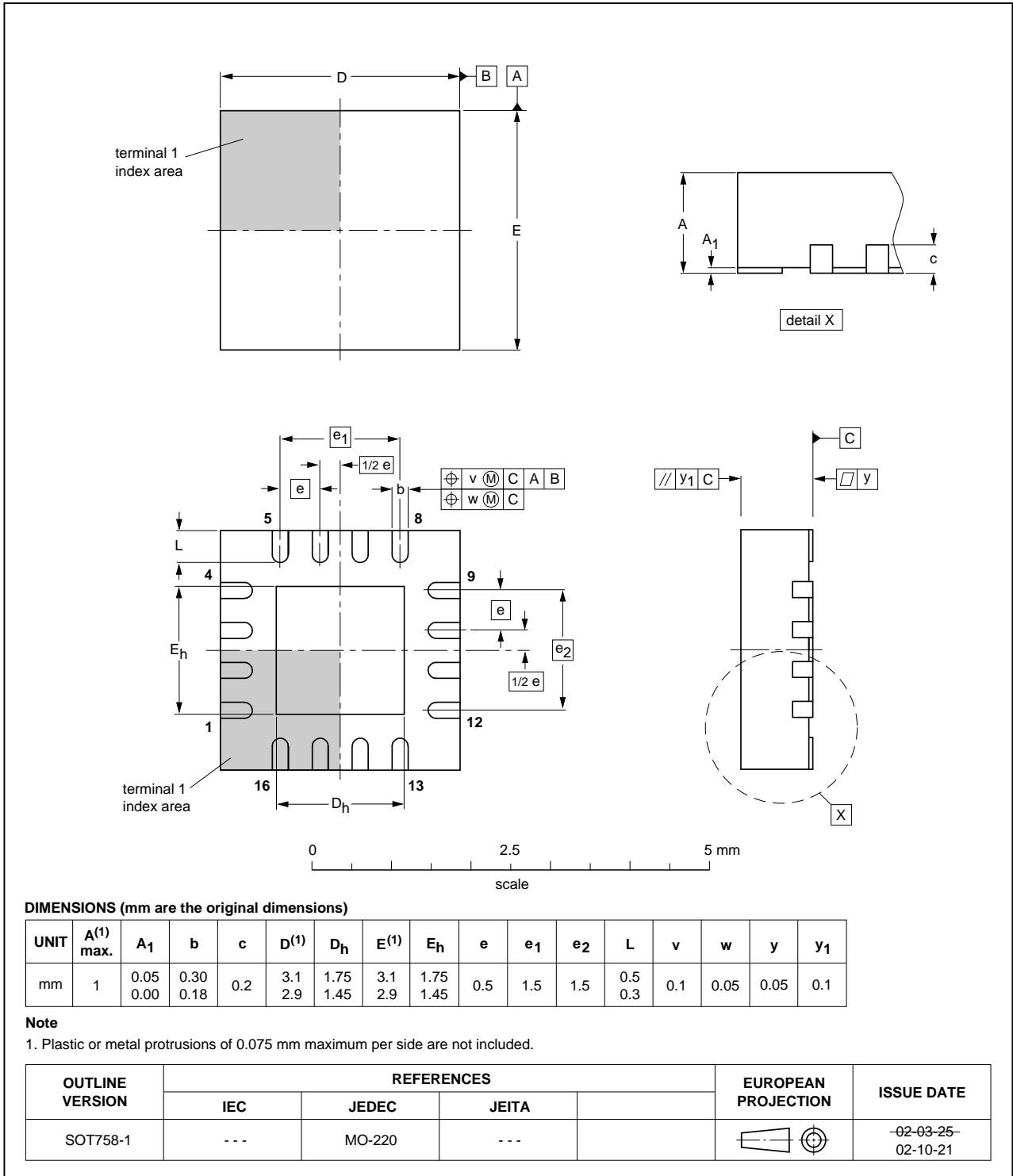

Fig 23. Package outline SOT758-1 (HVQFN16)

SO16: plastic small outline package; 16 leads; body width 7.5 mm

SOT162-1

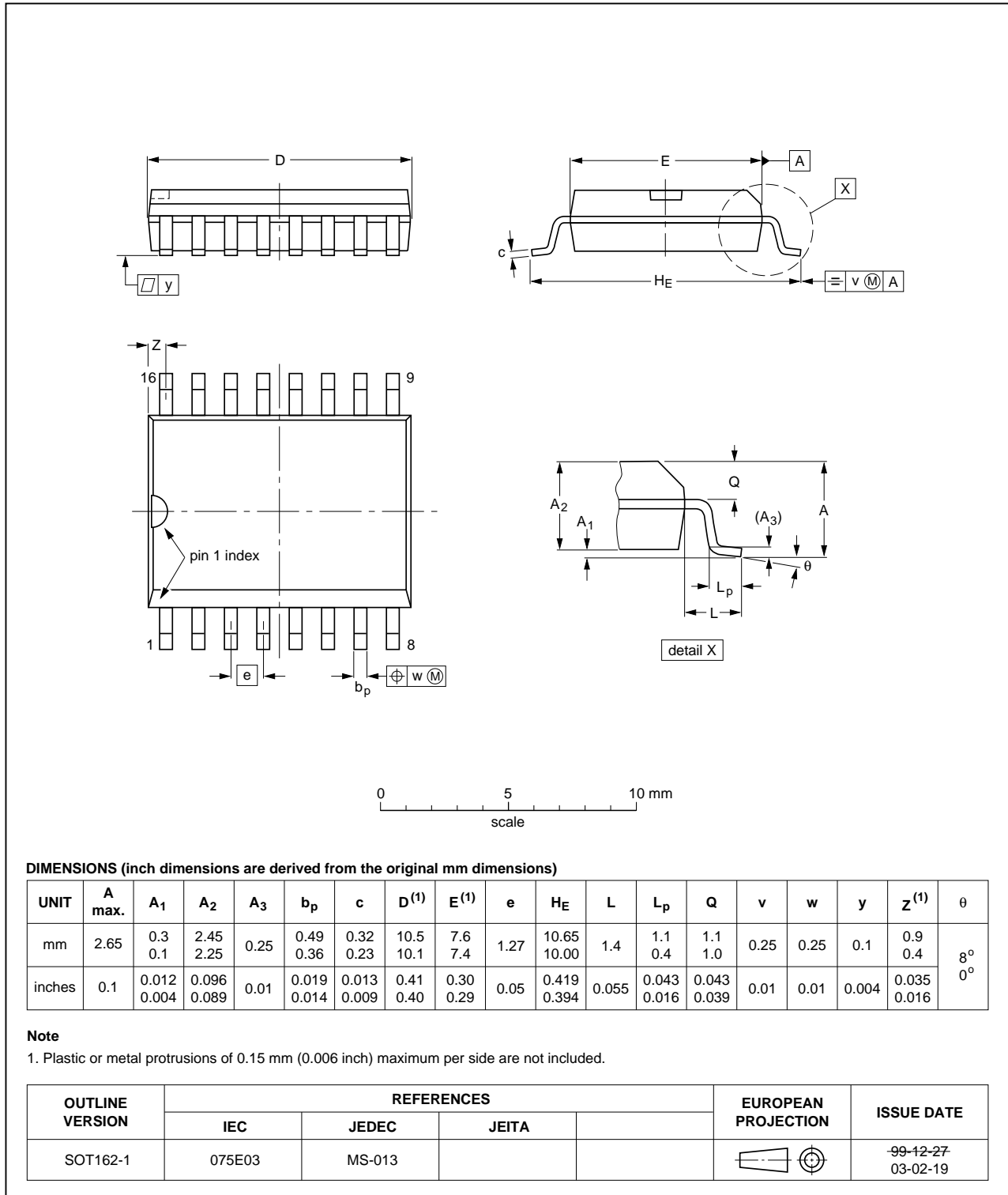

Fig 24. Package outline SOT162-1 (SO16)

TSSOP16: plastic thin shrink small outline package; 16 leads; body width 4.4 mm

SOT403-1

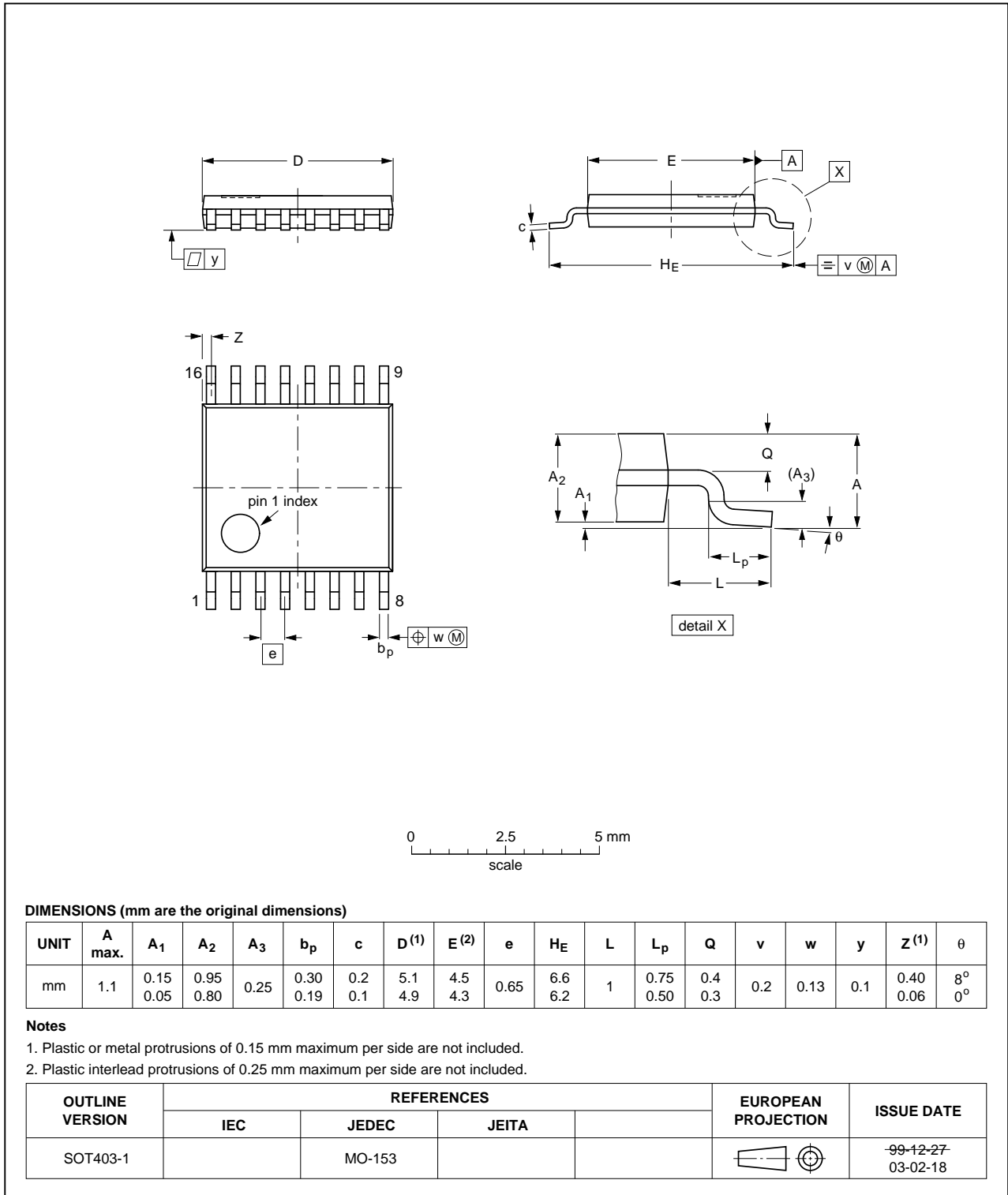

Fig 25. Package outline SOT403-1 (TSSOP16)

16. Handling information

All input and output pins are protected against ElectroStatic Discharge (ESD) under normal handling. When handling ensure that the appropriate precautions are taken as described in *JESD625-A* or equivalent standards.

17. Soldering of SMD packages

This text provides a very brief insight into a complex technology. A more in-depth account of soldering ICs can be found in Application Note *AN10365 "Surface mount reflow soldering description"*.

17.1 Introduction to soldering

Soldering is one of the most common methods through which packages are attached to Printed Circuit Boards (PCBs), to form electrical circuits. The soldered joint provides both the mechanical and the electrical connection. There is no single soldering method that is ideal for all IC packages. Wave soldering is often preferred when through-hole and Surface Mount Devices (SMDs) are mixed on one printed wiring board; however, it is not suitable for fine pitch SMDs. Reflow soldering is ideal for the small pitches and high densities that come with increased miniaturization.

17.2 Wave and reflow soldering

Wave soldering is a joining technology in which the joints are made by solder coming from a standing wave of liquid solder. The wave soldering process is suitable for the following:

- Through-hole components
- Leaded or leadless SMDs, which are glued to the surface of the printed circuit board

Not all SMDs can be wave soldered. Packages with solder balls, and some leadless packages which have solder lands underneath the body, cannot be wave soldered. Also, leaded SMDs with leads having a pitch smaller than ~0.6 mm cannot be wave soldered, due to an increased probability of bridging.

The reflow soldering process involves applying solder paste to a board, followed by component placement and exposure to a temperature profile. Leaded packages, packages with solder balls, and leadless packages are all reflow solderable.

Key characteristics in both wave and reflow soldering are:

- Board specifications, including the board finish, solder masks and vias
- Package footprints, including solder thieves and orientation
- The moisture sensitivity level of the packages
- Package placement
- Inspection and repair
- Lead-free soldering versus SnPb soldering

17.3 Wave soldering

Key characteristics in wave soldering are:

- Process issues, such as application of adhesive and flux, clinching of leads, board transport, the solder wave parameters, and the time during which components are exposed to the wave
- Solder bath specifications, including temperature and impurities

17.4 Reflow soldering

Key characteristics in reflow soldering are:

- Lead-free versus SnPb soldering; note that a lead-free reflow process usually leads to higher minimum peak temperatures (see [Figure 26](#)) than a SnPb process, thus reducing the process window
- Solder paste printing issues including smearing, release, and adjusting the process window for a mix of large and small components on one board
- Reflow temperature profile; this profile includes preheat, reflow (in which the board is heated to the peak temperature) and cooling down. It is imperative that the peak temperature is high enough for the solder to make reliable solder joints (a solder paste characteristic). In addition, the peak temperature must be low enough that the packages and/or boards are not damaged. The peak temperature of the package depends on package thickness and volume and is classified in accordance with [Table 10](#) and [11](#)

Table 10. SnPb eutectic process (from J-STD-020D)

Package thickness (mm)	Package reflow temperature (°C)	
	Volume (mm ³)	
	< 350	≥ 350
< 2.5	235	220
≥ 2.5	220	220

Table 11. Lead-free process (from J-STD-020D)

Package thickness (mm)	Package reflow temperature (°C)		
	Volume (mm ³)		
	< 350	350 to 2000	> 2000
< 1.6	260	260	260
1.6 to 2.5	260	250	245
> 2.5	250	245	245

Moisture sensitivity precautions, as indicated on the packing, must be respected at all times.

Studies have shown that small packages reach higher temperatures during reflow soldering, see [Figure 26](#).

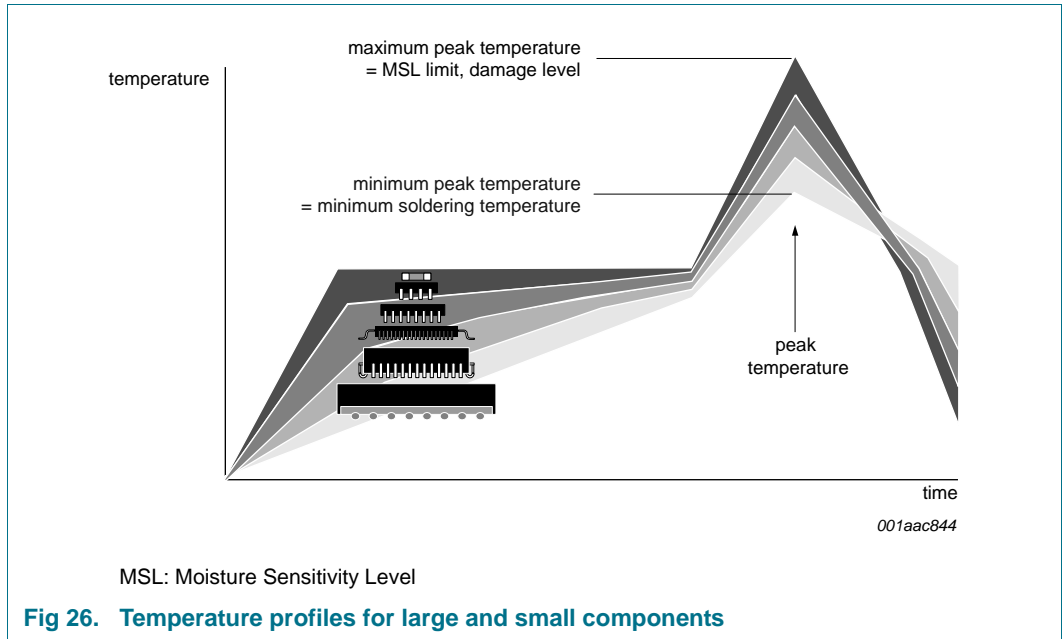

For further information on temperature profiles, refer to Application Note AN10365 “Surface mount reflow soldering description”.

18. Soldering: PCB footprints

Footprint information for reflow soldering of HVQFN16 package

SOT758-1

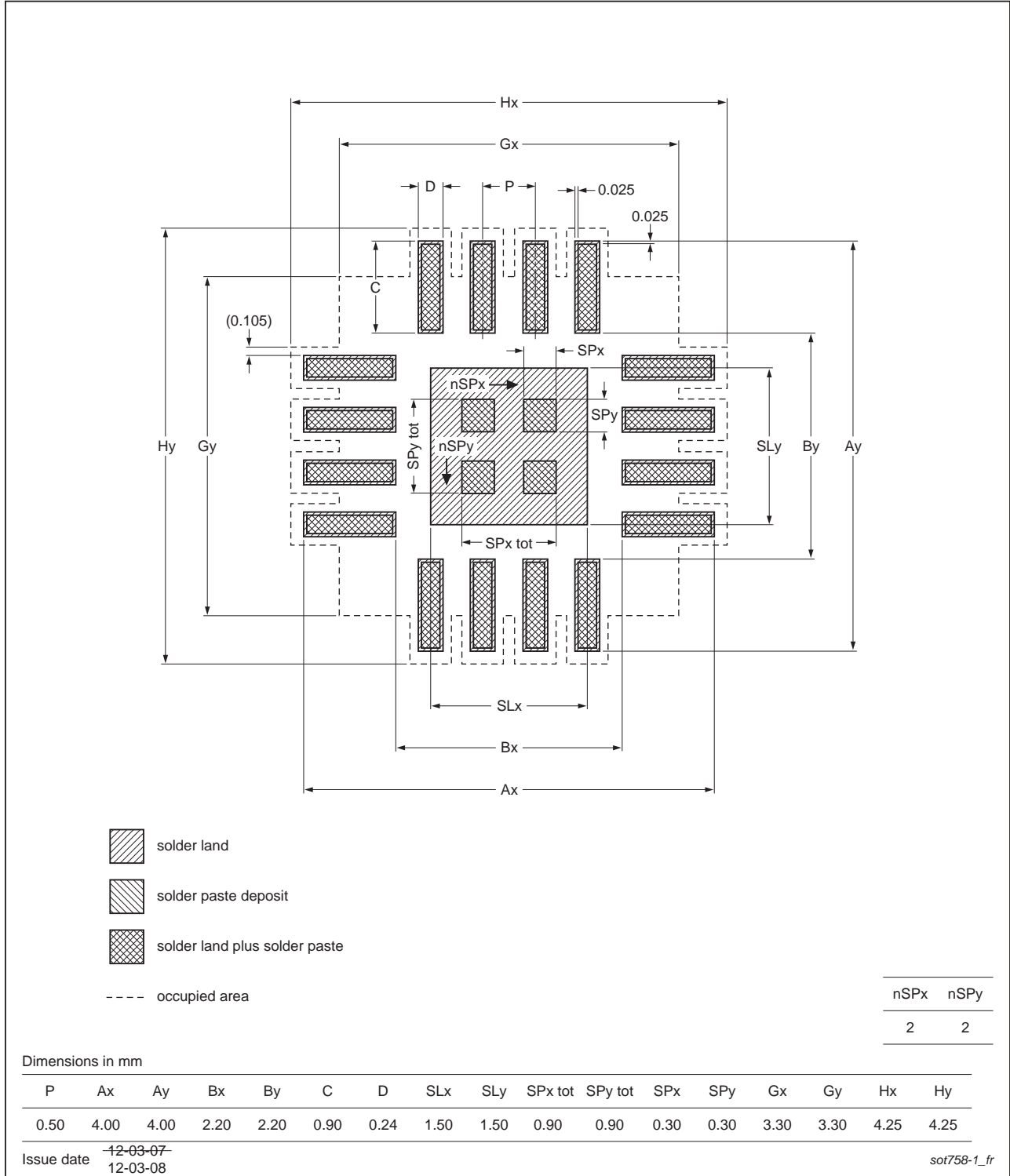

Fig 27. PCB footprint for SOT758-1 (HVQFN16); reflow soldering

Footprint information for reflow soldering of SO16 package

SOT162-1

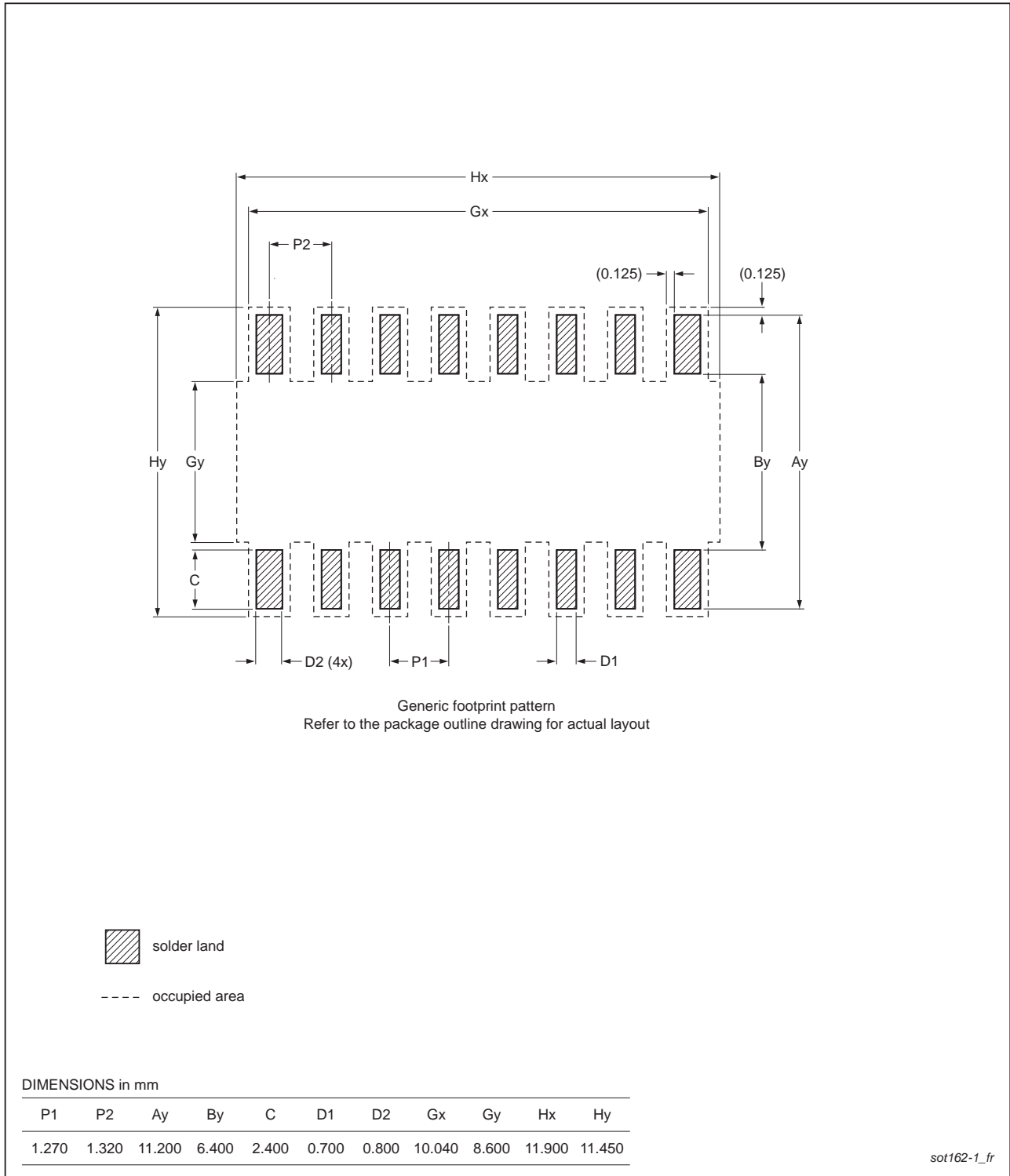

Fig 28. PCB footprint for SOT162-1 (SO16); reflow soldering

Footprint information for reflow soldering of TSSOP16 package

SOT403-1

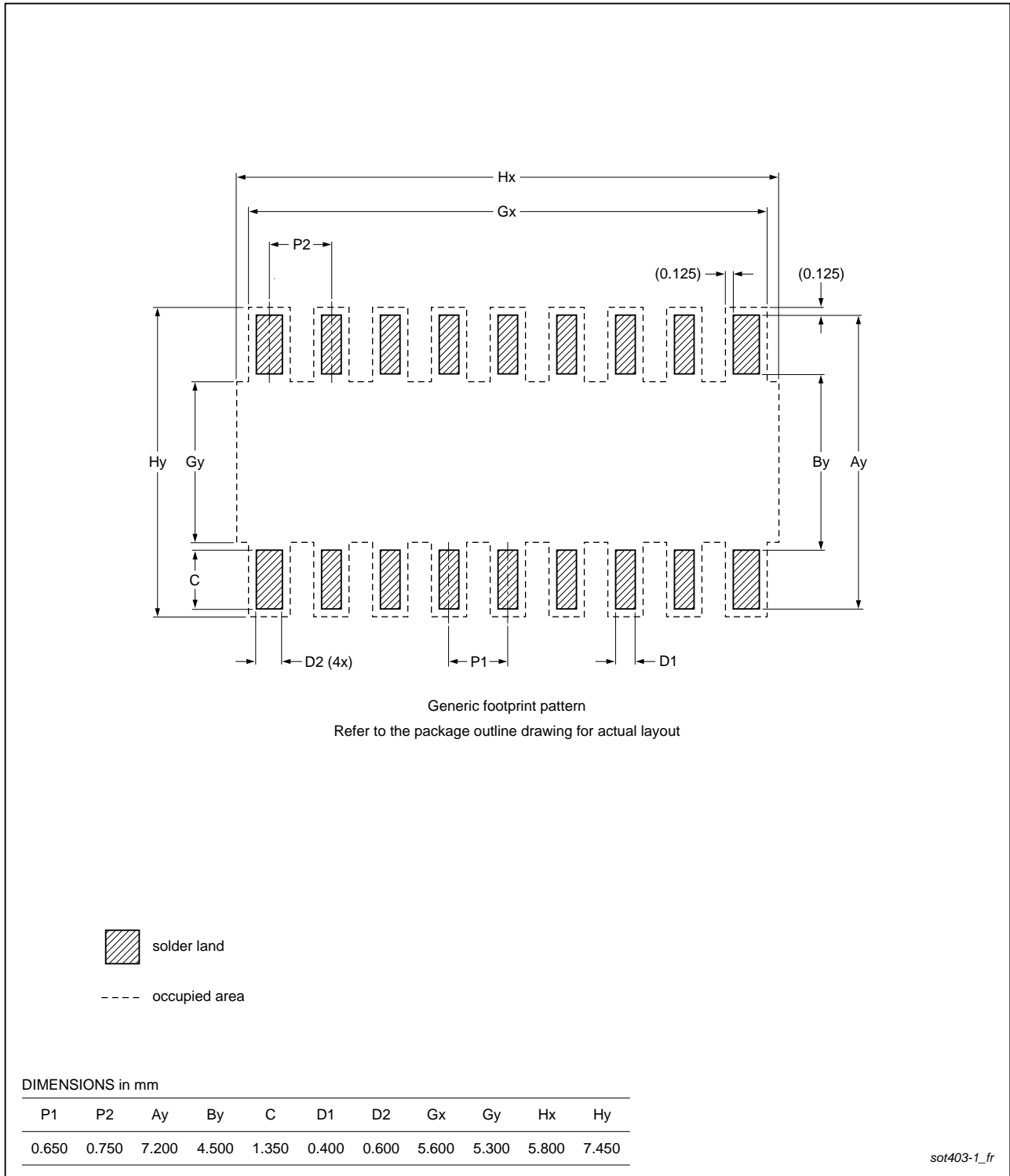

Fig 29. PCB footprint for SOT403-1 (TSSOP16); reflow soldering

19. Abbreviations

Table 12. Abbreviations

Acronym	Description
CDM	Charged-Device Model
CMOS	Complementary Metal-Oxide Semiconductor
ESD	ElectroStatic Discharge
GPIO	General Purpose Input/Output
HBM	Human Body Model
LED	Light Emitting Diode
IC	Integrated Circuit
I ² C-bus	Inter IC bus
ID	Identification
LSB	Least Significant Bit
MSB	Most Significant Bit
PLC	Programmable Logic Controller
RAID	Redundant Array of Independent Disks

20. Revision history

Table 13. Revision history

Document ID	Release date	Data sheet status	Change notice	Supersedes
PCA9670 v.3	20130530	Product data sheet	-	PCA9670 v.2

Modifications:

- [Section 1 “General description”](#) re-written
- [Section 2 “Features and benefits”](#) re-written
- [Section 3 “Applications”](#):
 - Added (new) third bullet, “Keypads”
 - Added (new) eighth bullet, “Mobile devices”
- Added [Section 4.1 “Ordering options”](#)
- [Figure 2 “Simplified schematic diagram of P0 to P7”](#) modified: removed diode between “V_{DD}” and “P0 to P7”; removed exclusive-OR gate and signal “to interrupt logic”
- [Section 7.1 “Device address”](#): re-written
- [Table 4 “PCA9670 address map”](#) updated: added separate columns for “Write” and “Read” under “Address byte value” column; added (new) column “7-bit hexadecimal address without R/W”
- [Section 7.2.1 “Software Reset”](#): added paragraph that follows [Figure 9](#)
- [Section 7.2.2 “Device ID \(PCA9670 ID field\)”](#):
 - first bullet item following first paragraph changed from “8 bits with the manufacturer name” to “12 bits with the manufacturer name”
 - second bullet item re-written
 - [List item 6. on page 9](#) changed from “starting with the 8 manufacturer bits ... , followed by the 13 part identification bits” to “starting with the 12 manufacturer bits ... , followed by the 9 part identification bits”
 - [Figure 10 “PCA9670 Device ID field”](#) modified
 - [Figure 11](#) modified: added “Sr” bit
 - added paragraph that follows [Figure 11](#)

Table 13. Revision history ...continued

Document ID	Release date	Data sheet status	Change notice	Supersedes
Modifications: (continued)				
			<ul style="list-style-type: none"> • Section 8.1 “Quasi-bidirectional I/O architecture” re-written • Section 8.2 “Writing to the port (Output mode)”, first paragraph: first, second and third sentences re-written • Figure 13 “Write mode (output)” updated • Section 8.3 “Reading from a port (Input mode)” re-written • Figure 14 “Read input port register” updated: label corrected from “data into port” to “data at port” • Section 8.4 “Power-on reset”: second and third sentences re-written • Section 8.5 “RESET input”: added new third sentence • Section 9.3 “Acknowledge”: <ul style="list-style-type: none"> – first paragraph: second and third sentences re-written – second paragraph: third sentence re-written • Section 10.1 “Bidirectional I/O expander applications”, second paragraph, second sentence changed from “use the PCA9671” to “use the PCA9672” • Added Section 10.2 “How to read and write to I/O expander (example)” • Section 10.3 “High current-drive load applications”: <ul style="list-style-type: none"> – first paragraph re-written – Figure 20 “High current-drive load application” modified: added resistors on P6 and P7 signals • Added Section 10.4 “Migration path” • Table 6 “Limiting values”: added $T_{j(max)}$ limits • Added Section 12 “Thermal characteristics” • Table 8 “Static characteristics”: <ul style="list-style-type: none"> – sub-section “I/Os; P0 to P7”: added V_{IL} characteristic – sub-section “I/Os; P0 to P7”: added V_{IH} characteristic – sub-section “Input RESET” is corrected by removing I_{OH} row • Figure 21 “I²C-bus timing diagram” updated: added $0.7 \times V_{DD}$ and $0.3 \times V_{DD}$ reference lines • Added Section 18 “Soldering: PCB footprints” 	
PCA9670 v.2	20070717	Product data sheet	-	PCA9670 v.1
PCA9670 v.1	20060620	Objective data sheet	-	-

21. Legal information

21.1 Data sheet status

Document status ^{[1][2]}	Product status ^[3]	Definition
Objective [short] data sheet	Development	This document contains data from the objective specification for product development.
Preliminary [short] data sheet	Qualification	This document contains data from the preliminary specification.
Product [short] data sheet	Production	This document contains the product specification.

[1] Please consult the most recently issued document before initiating or completing a design.

[2] The term 'short data sheet' is explained in section "Definitions".

[3] The product status of device(s) described in this document may have changed since this document was published and may differ in case of multiple devices. The latest product status information is available on the Internet at URL <http://www.nxp.com>.

21.2 Definitions

Draft — The document is a draft version only. The content is still under internal review and subject to formal approval, which may result in modifications or additions. NXP Semiconductors does not give any representations or warranties as to the accuracy or completeness of information included herein and shall have no liability for the consequences of use of such information.

Short data sheet — A short data sheet is an extract from a full data sheet with the same product type number(s) and title. A short data sheet is intended for quick reference only and should not be relied upon to contain detailed and full information. For detailed and full information see the relevant full data sheet, which is available on request via the local NXP Semiconductors sales office. In case of any inconsistency or conflict with the short data sheet, the full data sheet shall prevail.

Product specification — The information and data provided in a Product data sheet shall define the specification of the product as agreed between NXP Semiconductors and its customer, unless NXP Semiconductors and customer have explicitly agreed otherwise in writing. In no event however, shall an agreement be valid in which the NXP Semiconductors product is deemed to offer functions and qualities beyond those described in the Product data sheet.

21.3 Disclaimers

Limited warranty and liability — Information in this document is believed to be accurate and reliable. However, NXP Semiconductors does not give any representations or warranties, expressed or implied, as to the accuracy or completeness of such information and shall have no liability for the consequences of use of such information. NXP Semiconductors takes no responsibility for the content in this document if provided by an information source outside of NXP Semiconductors.

In no event shall NXP Semiconductors be liable for any indirect, incidental, punitive, special or consequential damages (including - without limitation - lost profits, lost savings, business interruption, costs related to the removal or replacement of any products or rework charges) whether or not such damages are based on tort (including negligence), warranty, breach of contract or any other legal theory.

Notwithstanding any damages that customer might incur for any reason whatsoever, NXP Semiconductors' aggregate and cumulative liability towards customer for the products described herein shall be limited in accordance with the *Terms and conditions of commercial sale* of NXP Semiconductors.

Right to make changes — NXP Semiconductors reserves the right to make changes to information published in this document, including without limitation specifications and product descriptions, at any time and without notice. This document supersedes and replaces all information supplied prior to the publication hereof.

Suitability for use — NXP Semiconductors products are not designed, authorized or warranted to be suitable for use in life support, life-critical or safety-critical systems or equipment, nor in applications where failure or malfunction of an NXP Semiconductors product can reasonably be expected to result in personal injury, death or severe property or environmental damage. NXP Semiconductors and its suppliers accept no liability for inclusion and/or use of NXP Semiconductors products in such equipment or applications and therefore such inclusion and/or use is at the customer's own risk.

Applications — Applications that are described herein for any of these products are for illustrative purposes only. NXP Semiconductors makes no representation or warranty that such applications will be suitable for the specified use without further testing or modification.

Customers are responsible for the design and operation of their applications and products using NXP Semiconductors products, and NXP Semiconductors accepts no liability for any assistance with applications or customer product design. It is customer's sole responsibility to determine whether the NXP Semiconductors product is suitable and fit for the customer's applications and products planned, as well as for the planned application and use of customer's third party customer(s). Customers should provide appropriate design and operating safeguards to minimize the risks associated with their applications and products.

NXP Semiconductors does not accept any liability related to any default, damage, costs or problem which is based on any weakness or default in the customer's applications or products, or the application or use by customer's third party customer(s). Customer is responsible for doing all necessary testing for the customer's applications and products using NXP Semiconductors products in order to avoid a default of the applications and the products or of the application or use by customer's third party customer(s). NXP does not accept any liability in this respect.

Limiting values — Stress above one or more limiting values (as defined in the Absolute Maximum Ratings System of IEC 60134) will cause permanent damage to the device. Limiting values are stress ratings only and (proper) operation of the device at these or any other conditions above those given in the Recommended operating conditions section (if present) or the Characteristics sections of this document is not warranted. Constant or repeated exposure to limiting values will permanently and irreversibly affect the quality and reliability of the device.

Terms and conditions of commercial sale — NXP Semiconductors products are sold subject to the general terms and conditions of commercial sale, as published at <http://www.nxp.com/profile/terms>, unless otherwise agreed in a valid written individual agreement. In case an individual agreement is concluded only the terms and conditions of the respective agreement shall apply. NXP Semiconductors hereby expressly objects to applying the customer's general terms and conditions with regard to the purchase of NXP Semiconductors products by customer.

No offer to sell or license — Nothing in this document may be interpreted or construed as an offer to sell products that is open for acceptance or the grant, conveyance or implication of any license under any copyrights, patents or other industrial or intellectual property rights.

Export control — This document as well as the item(s) described herein may be subject to export control regulations. Export might require a prior authorization from competent authorities.

Non-automotive qualified products — Unless this data sheet expressly states that this specific NXP Semiconductors product is automotive qualified, the product is not suitable for automotive use. It is neither qualified nor tested in accordance with automotive testing or application requirements. NXP Semiconductors accepts no liability for inclusion and/or use of non-automotive qualified products in automotive equipment or applications.

In the event that customer uses the product for design-in and use in automotive applications to automotive specifications and standards, customer (a) shall use the product without NXP Semiconductors' warranty of the product for such automotive applications, use and specifications, and (b) whenever customer uses the product for automotive applications beyond NXP Semiconductors' specifications such use shall be solely at customer's

own risk, and (c) customer fully indemnifies NXP Semiconductors for any liability, damages or failed product claims resulting from customer design and use of the product for automotive applications beyond NXP Semiconductors' standard warranty and NXP Semiconductors' product specifications.

Translations — A non-English (translated) version of a document is for reference only. The English version shall prevail in case of any discrepancy between the translated and English versions.

21.4 Trademarks

Notice: All referenced brands, product names, service names and trademarks are the property of their respective owners.

I²C-bus — logo is a trademark of NXP B.V.

22. Contact information

For more information, please visit: <http://www.nxp.com>

For sales office addresses, please send an email to: salesaddresses@nxp.com

23. Contents

1	General description	1	19	Abbreviations	31
2	Features and benefits	1	20	Revision history	31
3	Applications	2	21	Legal information	33
4	Ordering information	2	21.1	Data sheet status	33
4.1	Ordering options	2	21.2	Definitions	33
5	Block diagram	3	21.3	Disclaimers	33
6	Pinning information	4	21.4	Trademarks	34
6.1	Pinning	4	22	Contact information	34
6.2	Pin description	4	23	Contents	35
7	Functional description	5			
7.1	Device address	5			
7.1.1	Address maps	6			
7.2	Software Reset Call, and device ID addresses	8			
7.2.1	Software Reset	8			
7.2.2	Device ID (PCA9670 ID field)	9			
8	I/O programming	11			
8.1	Quasi-bidirectional I/O architecture	11			
8.2	Writing to the port (Output mode)	12			
8.3	Reading from a port (Input mode)	13			
8.4	Power-on reset	13			
8.5	RESET input	13			
9	Characteristics of the I²C-bus	14			
9.1	Bit transfer	14			
9.1.1	START and STOP conditions	14			
9.2	System configuration	15			
9.3	Acknowledge	15			
10	Application design-in information	16			
10.1	Bidirectional I/O expander applications	16			
10.2	How to read and write to I/O expander (example)	16			
10.3	High current-drive load applications	17			
10.4	Migration path	17			
11	Limiting values	18			
12	Thermal characteristics	18			
13	Static characteristics	19			
14	Dynamic characteristics	20			
15	Package outline	22			
16	Handling information	25			
17	Soldering of SMD packages	25			
17.1	Introduction to soldering	25			
17.2	Wave and reflow soldering	25			
17.3	Wave soldering	25			
17.4	Reflow soldering	26			
18	Soldering: PCB footprints	28			

Please be aware that important notices concerning this document and the product(s) described herein, have been included in section 'Legal information'.

© NXP B.V. 2013.

All rights reserved.

For more information, please visit: <http://www.nxp.com>



For sales office addresses, please send an email to: salesaddresses@nxp.com

Date of release: 30 May 2013

Document identifier: PCA9670

Looking for pricing, stock, or lifecycle information?

Click below to explore more details on WIN SOURCE:

-  [View PCA9670PW,118 on WIN SOURCE](#)
-  [NXP / Nexperia Information](#)

Optimize Your Supply Chain with WIN SOURCE Solutions

-  Global Sourcing Solution
-  Obsolete Management
-  Cost Control Management
-  Shortage Management
-  Alternative Solution
-  Excess Inventory Management