



THE DATASHEET OF CDCE706PWR



PROGRAMMABLE 3-PLL CLOCK SYNTHESIZER/MULTIPLIER/DIVIDER

FEATURES

- High-Performance 3:6 PLL-Based Clock Synthesizer/Multiplier/Divider
- User-Programmable PLL Frequencies
- EEPROM Programming Without the Need to Apply High Programming Voltage
- Easy In-Circuit Programming via SMBus Data Interface
- Wide PLL Divider Ratio Allows 0-ppm Output Clock Error
- Clock Inputs Accept a Crystal, a Single-Ended LVCMOS, or a Differential Input Signal
- Accepts Crystal Frequencies From 8 MHz to 54 MHz
- Accepts LVCMOS or Differential Input Frequencies up to 200 MHz
- Two Programmable Control Inputs [S0/S1, A0/A1] for User-Defined Control Signals
- Six LVCMOS Outputs With Output Frequencies up to 300 MHz
- LVCMOS Outputs Can Be Programmed for Complementary Signals
- Free Selectable Output Frequency via Programmable Output Switching Matrix [6×6] Including 7-Bit Post-Divider for Each Output
- PLL Loop Filter Components Integrated
- Low Period Jitter (Typically 60 ps)
- Features Spread-Spectrum Clocking (SSC) for Lowering System EMI
- Programmable Output Slew-Rate Control (SRC) for Lowering System EMI
- 3.3-V Device Power Supply
- Industrial Temperature Range –40°C to 85°C
- Development and Programming Kit for Easy PLL Design and Programming (TI ClockPro Software)
- Packaged in 20-Pin TSSOP

TERMINAL ASSIGNMENT

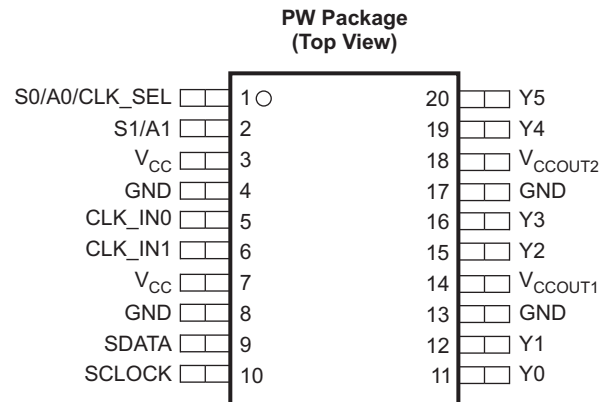

P0087-01

DESCRIPTION

The CDCE706 is one of the smallest and most powerful PLL synthesizer/multiplier/dividers available today. Despite its small physical outline, the CDCE706 is very flexible. It has the capability to produce an almost independent output frequency from a given input frequency.

The input frequency can be derived from an LVCMOS, differential input clock, or single crystal. The appropriate input waveform can be selected via the SMBus data interface controller.

To achieve an independent output frequency, the reference divider M and the feedback divider N for each PLL can be set to values from 1 to 511 for the M-divider and from 1 to 4095 for the N-divider. The PLL-VCO (voltage controlled oscillator) frequency then is routed from the programmable output switching matrix to any of the six outputs. The switching matrix includes an additional 7-bit post-divider (1 to 127) and an inverting logic for each output.

The deep M/N divider ratio allows the generation of zero-ppm clocks from any reference input frequency (e.g., 27 MHz).

The CDCE706 includes three PLLs; of those, one supports spread-spectrum clocking (SSC). PLL1, PLL2, and PLL3 are designed for frequencies up to 300 MHz and optimized for zero-ppm applications with wide divider factors.



Please be aware that an important notice concerning availability, standard warranty, and use in critical applications of Texas Instruments semiconductor products and disclaimers thereto appears at the end of this data sheet.



These devices have limited built-in ESD protection. The leads should be shorted together or the device placed in conductive foam during storage or handling to prevent electrostatic damage to the MOS gates.

DESCRIPTION (CONTINUED)

PLL2 also supports center- and down-spread-spectrum clocking (SSC). This is a common technique to reduce electromagnetic interference. Also, the slew-rate controllable (SRC) output edges minimize EMI noise.

Based on the PLL frequency and the divider settings, the internal loop filter components are automatically adjusted to achieve the high stability and optimized jitter transfer characteristic of the PLL.

The device supports nonvolatile EEPROM programming for easily customized application. The device is preprogrammed with a factory default configuration (see [Figure 13](#)) and can be reprogrammed to a different application configuration before it goes onto the PCB or reprogrammed by in-system programming. A different device setting is programmed via the serial SMBus interface.

Two free programmable inputs, S0 and S1, can be used to control for each application the most demanding logic control settings (outputs disable to low, outputs 3-state, power down, PLL bypass, etc).

The CDCE706 has three power-supply pins, V_{CC} , V_{CCOUT1} , and V_{CCOUT2} . V_{CC} is the power supply for the device. It operates from a single 3.3-V supply voltage. V_{CCOUT1} and V_{CCOUT2} are the power supply pins for the outputs. V_{CCOUT1} supplies the outputs Y0 and Y1, and V_{CCOUT2} supplies the outputs Y2, Y3, Y4, and Y5. Both output supplies can be 2.3 V to 3.6 V. At output voltages lower than 3.3 V, the output drive current is limited.

The CDCE706 is characterized for operation from -40°C to 85°C .

FUNCTIONAL BLOCK DIAGRAM

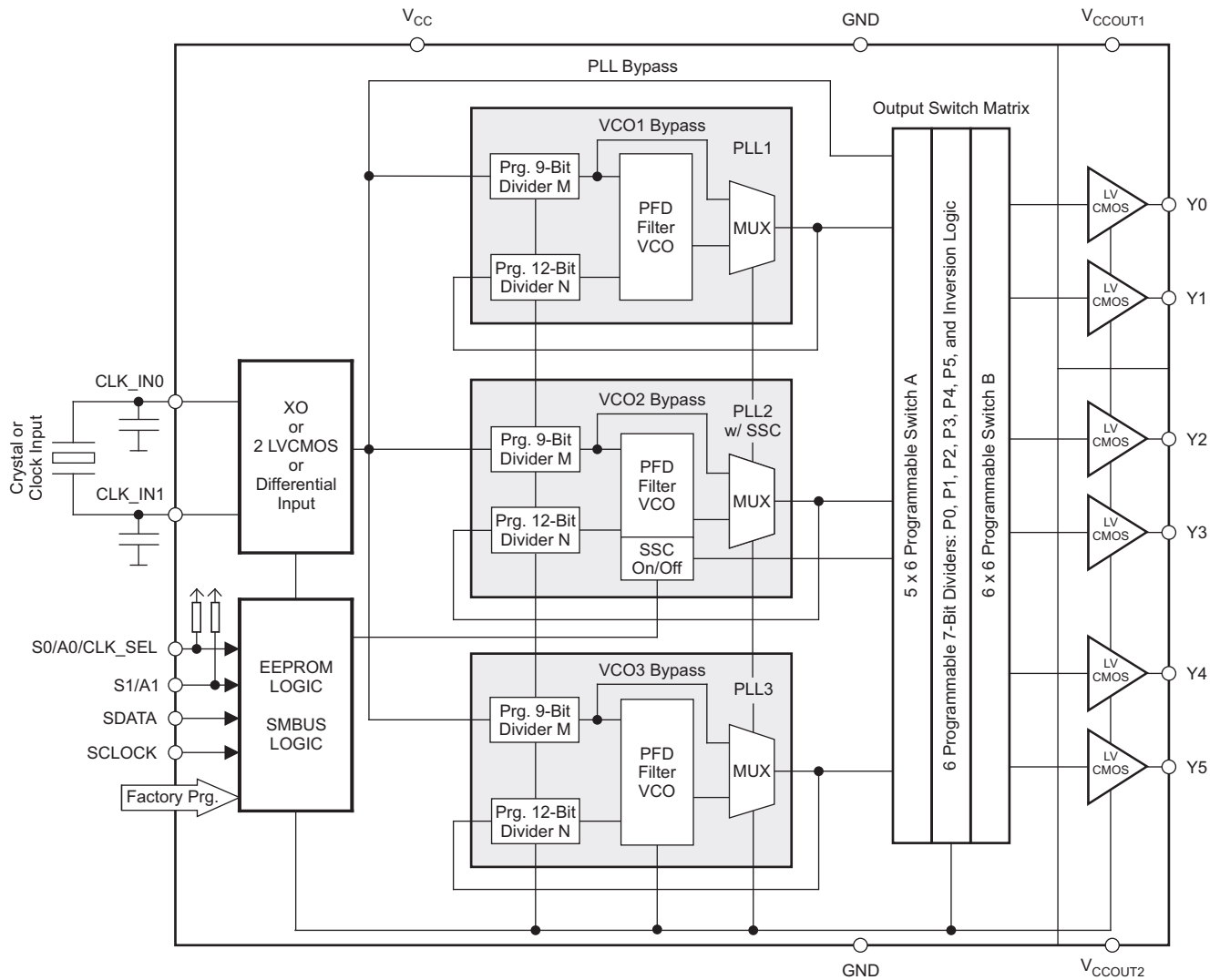

B0334-01

OUTPUT SWITCH MATRIX

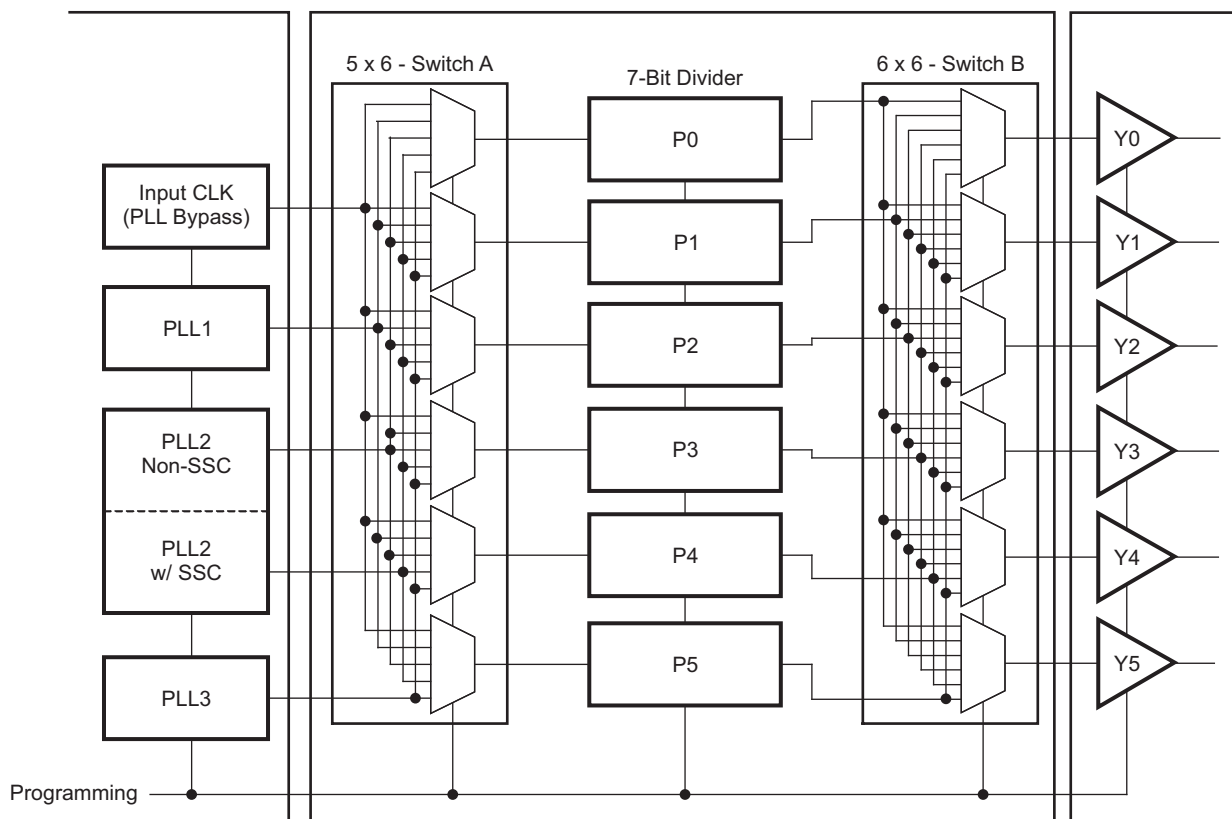

B0335-01

TERMINAL FUNCTIONS

TERMINAL		I/O	DESCRIPTION
NAME	TSSOP20 NO.		
CLK_IN0	5	I	Dependent on SMBus settings, CLK_IN0 is the crystal-oscillator input and can also be used as an LVC MOS input or as positive differential signal inputs.
CLK_IN1	6	I/O	Depending on SMBus settings, CLK_IN1 serves as the crystal oscillator output or can be the second LVC MOS input or the negative differential signal input.
GND	4, 8, 13, 17	Ground	Ground
S0, A0, CLK_SEL	1	I	User-programmable control input S0 (PLL bypass or power-down mode) or A0 (address bit 0), or CLK_SEL (selects one of two LVC MOS clock inputs), dependent on the SMBus settings; LVC MOS inputs; internal pullup 150 kΩ
S1, A1	2	I	User-programmable control input S1 (output enable/disable or all output low), A1 (address bit 1), dependent on the SMBus settings; LVC MOS inputs; internal pullup 150 kΩ
SCLOCK	10	I	Serial control clock input for SMBus controller; LVC MOS input
SDATA	9	I/O	Serial control data input/output for SMBus controller; LVC MOS input
V _{CC}	3, 7	Power	3.3-V power supply for the device
V _{CCOUT1}	14	Power	Power supply for outputs Y0, Y1
V _{CCOUT2}	18	Power	Power supply for outputs Y2, Y3, Y4, Y5
Y0 to Y5	11, 12, 15, 16, 19, 20	O	LVC MOS outputs

ABSOLUTE MAXIMUM RATINGS

over operating free-air temperature range (unless otherwise noted)⁽¹⁾

		VALUE	UNIT
V_{CC}	Supply voltage range	–0.5 to 4.6	V
V_I	Input voltage range ⁽²⁾	–0.5 to $V_{CC} + 0.5$	V
V_O	Output voltage range ⁽²⁾	–0.5 to $V_{CC} + 0.5$	V
I_I	Input current ($V_I < 0$, $V_I > V_{CC}$)	±20	mA
I_O	Continuous output current	±50	mA
T_{stg}	Storage temperature range	–65 to 150	°C
T_J	Maximum junction temperature	125	°C

- (1) Stresses beyond those listed under *absolute maximum ratings* may cause permanent damage to the device. These are stress ratings only and functional operation of the device at these or any other conditions beyond those indicated under *recommended operating conditions* is not implied. Exposure to absolute maximum rated conditions for extended periods may affect device reliability.
- (2) The input and output negative voltage ratings may be exceeded if the input and output clamp-current ratings are observed.

PACKAGE THERMAL RESISTANCE

for TSSOP20 (PW) Package⁽¹⁾

PARAMETER		AIRFLOW (LFM)	AIRFLOW (m/s)	°C/W
θ_{JA}	Thermal resistance, junction-to-ambient	0	0	66.3
		150	0.762	59.3
		250	1.27	56.3
		500	2.54	51.9
θ_{JC}	Thermal resistance, junction-to-case			19.7

- (1) The package thermal impedance is calculated in accordance with JESD 51 and JEDEC2S2P (high-k board).

RECOMMENDED OPERATING CONDITIONS

over operating free-air temperature range (unless otherwise noted)

		MIN	NOM	MAX	UNIT
V_{CC}	Device supply voltage	3	3.3	3.6	V
V_{CCOUT1} ⁽¹⁾	Output Y0, Y1 supply voltage	2.3		3.6	V
V_{CCOUT2} ⁽¹⁾	Output Y2, Y3, Y4, Y5 supply voltage	2.3		3.6	V
V_{IL}	Low-level input voltage, LVCMOS			0.3 V_{CC}	V
V_{IH}	High-level input voltage, LVCMOS	0.7 V_{CC}			V
$V_{Ithresh}$	Input voltage threshold, LVCMOS		0.5 V_{CC}		V
V_I	Input voltage range, LVCMOS	0		3.6	V
$ V_{ID} $	Differential input voltage	0.1			V
V_{IC}	Common-mode for differential input voltage	0.2		$V_{CC} - 0.6$	V
I_{OH}/I_{OL}	Output current (3.3 V)			±6	mA
I_{OH}/I_{OL}	Output current (2.5 V)			±4	mA
C_L	Output load, LVCMOS			25	pF
T_A	Operating free-air temperature	–40		85	°C

- (1) The minimum output voltage can be down to 1.8 V. See the *CDCx706/x906 Termination and Signal Integrity Guidelines* application report (SCAA080) for more information.

RECOMMENDED CRYSTAL SPECIFICATIONS

	MIN	NOM	MAX	UNIT
f_{Xtal} Crystal input frequency range (fundamental mode)	8	27	54	MHz
ESR Effective series resistance ⁽¹⁾⁽²⁾	15		60	Ω
C_{IN} Input capacitance CLK_IN0 and CLK_IN1		3		pF

- (1) For crystal frequencies above 50 MHz, the effective series resistor should not exceed 50 Ω to assure stable start-up condition.
(2) For maximum power handling (drive level), see [Figure 15](#).

EEPROM SPECIFICATION

	MIN	TYP	MAX	UNIT
EEcyc Programming cycles of EEPROM	100	1000		Cycles
EEret Data retention	10			Years

TIMING REQUIREMENTS

over recommended ranges of supply voltage, load, and operating-free air temperature

	MIN	NOM	MAX	UNIT
CLK_IN REQUIREMENTS				
f_{CLK_IN} CLK_IN clock input frequency (LVCMOS or differential)	PLL mode	1	200	MHz
	PLL bypass mode	0	200	
t_r/t_f Rise and fall time, CLK_IN signal (20% to 80%)			4	ns
duty _{REF} Duty cycle, CLK_IN at $V_{CC}/2$	40%		60%	
SMBus TIMING REQUIREMENTS (see Figure 11)				
f_{SCLK} SCLK frequency			100	kHz
$t_{h(START)}$ START hold time	4			μ s
$t_{w(SCLL)}$ SCLK low-pulse duration	4.7			μ s
$t_{w(SCLH)}$ SCLK high-pulse duration	4		50	μ s
$t_{su(START)}$ START setup time	0.6			μ s
$t_{h(SDATA)}$ SDATA hold time	0.3			μ s
$t_{su(SDATA)}$ SDATA setup time	0.25			μ s
$t_{r(SDATA)}/t_{r(SM)}$ SCLK/SDATA input rise time			1000	ns
$t_{f(SDATA)}/t_{f(SM)}$ SCLK/SDATA input fall time			300	ns
$t_{su(STOP)}$ STOP setup time	4			μ s
$t_{(BUS)}$ Bus free time	4.7			μ s
$t_{(POR)}$ Time in which the device must be operational after power-on reset			500	ms

DEVICE CHARACTERISTICS

over recommended operating free-air temperature range and test load (unless otherwise noted), see [Figure 1](#)

PARAMETER	TEST CONDITIONS	MIN	TYP ⁽¹⁾	MAX	UNIT
OVERALL PARAMETER					
I_{CC} Supply current ⁽²⁾	All PLLs on, all outputs on, $f_{OUT} = 80$ MHz, $f_{CLK_IN} = 27$ MHz, $f_{VCO} = 160$ MHz		90	115	mA
I_{CCPD} Power-down current	Every circuit powered down except SMBus, $f_{IN} = 0$ MHz, $V_{CC} = 3.6$ V		50		μ A
V_{PUC} Supply voltage V_{CC} threshold for power-up control circuit			2.1		V

- (1) All typical values are at nominal V_{CC} .
(2) For calculating total supply current, add the current from [Figure 2](#), [Figure 3](#), and [Figure 4](#). Using the high-speed mode of the VCO reduces the current consumption. See [Figure 3](#).

DEVICE CHARACTERISTICS (continued)

 over recommended operating free-air temperature range and test load (unless otherwise noted), see [Figure 1](#)

PARAMETER		TEST CONDITIONS		MIN	TYP ⁽¹⁾	MAX	UNIT
f_{VCO}	VCO frequency of internal PLL (any of three PLLs)	Normal speed-mode ⁽³⁾	All PLLs	80		200	MHz
			PLL2 with SSC	80		167	
		High-speed mode ⁽³⁾		180		300	
f_{OUT}	LVCMOS output frequency range ⁽⁴⁾ , See Figure 4	$V_{CC} = 2.5\text{ V}$				250	MHz
		$V_{CC} = 3.3\text{ V}$				300	
LVCMOS PARAMETER							
V_{IK}	LVCMOS input voltage	$V_{CC} = 3\text{ V}$, $I_I = -18\text{ mA}$				-1.2	V
I_I	LVCMOS input current (CLK_IN0 and CLK_IN1)	$V_I = 0\text{ V}$ or V_{CC} , $V_{CC} = 3.6\text{ V}$				±5	µA
I_{IH}	LVCMOS input current (S1/S0)	$V_I = V_{CC}$, $V_{CC} = 3.6\text{ V}$				5	µA
I_{IL}	LVCMOS input current (S1/S0)	$V_I = 0\text{ V}$, $V_{CC} = 3.6\text{ V}$		-35		-10	µA
C_I	Input capacitance at CLK_IN0 and CLK_IN1	$V_I = 0\text{ V}$ or V_{CC}			3		pF
LVCMOS PARAMETER FOR $V_{CCOUT} = 3.3\text{-V Mode}$							
V_{OH}	LVCMOS high-level output voltage	$V_{CCOUT} = 3\text{ V}$, $I_{OH} = -0.1\text{ mA}$		2.9			V
		$V_{CCOUT} = 3\text{ V}$, $I_{OH} = -4\text{ mA}$		2.4			
		$V_{CCOUT} = 3\text{ V}$, $I_{OH} = -6\text{ mA}$		2.1			
V_{OL}	LVCMOS low-level output voltage	$V_{CCOUT} = 3\text{ V}$, $I_{OL} = 0.1\text{ mA}$				0.1	V
		$V_{CCOUT} = 3\text{ V}$, $I_{OL} = 4\text{ mA}$				0.5	
		$V_{CCOUT} = 3\text{ V}$, $I_{OL} = 6\text{ mA}$				0.85	
t_{PLH} , t_{PHL}	Propagation delay	All PLL bypass			9		ns
		VCO bypass			11		
t_{r0}/t_{f0}	Rise and fall time for output slew rate 0	$V_{CCOUT} = 3.3\text{ V}$ (20%–80%)		1.7	3.3	4.8	ns
t_{r1}/t_{f1}	Rise and fall time for output slew rate 1	$V_{CCOUT} = 3.3\text{ V}$ (20%–80%)		1.5	2.5	3.2	ns
t_{r2}/t_{f2}	Rise and fall time for output slew rate 2	$V_{CCOUT} = 3.3\text{ V}$ (20%–80%)		1.2	1.6	2.1	ns
t_{r3}/t_{f3}	Rise and fall time for output slew rate 3 (default configuration)	$V_{CCOUT} = 3.3\text{ V}$ (20%–80%)		0.4	0.6	1	ns
$t_{jit(cc)}$	Cycle-to-cycle jitter ⁽⁵⁾⁽⁶⁾	1 PLL, 1 output	$f_{OUT} = 50\text{ MHz}$		55	90	ps
			$f_{OUT} = 245.76\text{ MHz}$		45	80	
		3 PLLs, 3 outputs	$f_{OUT} = 50\text{ MHz}$		125	155	
			$f_{OUT} = 245.76\text{ MHz}$		60	95	
$t_{jit(per)}$	Peak-to-peak period jitter ⁽⁵⁾⁽⁶⁾	1 PLL, 1 output	$f_{OUT} = 50\text{ MHz}$		60	90	ps
			$f_{OUT} = 245.76\text{ MHz}$		55	80	
		3 PLLs, 3 outputs	$f_{OUT} = 50\text{ MHz}$		145	180	
			$f_{OUT} = 245.76\text{ MHz}$		70	105	
$t_{sk(o)}$	Output skew (see ⁽⁷⁾ and Table 5)	1.6-ns rise/fall time at $f_{VCO} = 150\text{ MHz}$, $P_{div} = 3$				200	ps
odc	Output duty cycle ⁽⁸⁾	$f_{VCO} = 100\text{ MHz}$, $P_{div} = 1$		45%		55%	

(3) Normal-speed mode or high-speed mode must be selected by the VCO frequency selection bit in byte 6, bits [7:5]. The minimum f_{VCO} can be lower, but impacts jitter performance.

(4) Do not exceed the maximum power dissipation of the 20-pin TSSOP package (600 mW at no air flow).

(5) 50,000 cycles

(6) Jitter depends on configuration. Jitter data is normal t_r/t_f , input frequency = 3.84 MHz, $f_{VCO} = 245.76\text{ MHz}$.

(7) The $t_{sk(o)}$ specification is only valid for equal loading of all outputs.

(8) odc depends on output rise and fall time (t_r/t_f). The data is for normal t_r/t_f and is valid for both SSC on and off.

DEVICE CHARACTERISTICS (continued)

over recommended operating free-air temperature range and test load (unless otherwise noted), see [Figure 1](#)

PARAMETER		TEST CONDITIONS	MIN	TYP ⁽¹⁾	MAX	UNIT	
LVC MOS PARAMETER FOR V_{CCOUT} = 2.5-V Mode⁽⁹⁾							
V _{OH}	LVCMOS high-level output voltage	V _{CCOUT} = 2.3 V, I _{OH} = 0.1 mA	2.2			V	
		V _{CCOUT} = 2.3 V, I _{OH} = –3 mA	1.7				
		V _{CCOUT} = 2.3 V, I _{OH} = –4 mA	1.5				
V _{OL}	LVCMOS low-level output voltage	V _{CCOUT} = 2.3 V, I _{OL} = 0.1 mA			0.1	V	
		V _{CCOUT} = 2.3 V, I _{OL} = 3 mA			0.5		
		V _{CCOUT} = 2.3 V, I _{OL} = 4 mA			0.85		
t _{PLH} , t _{PHL}	Propagation delay	All PLL bypass		9		ns	
		VCO bypass		11			
t _{r0} /t _{f0}	Rise and fall time for output slew rate 0	V _{CCOUT} = 2.5 V (20%–80%)	2	3.9	5.6	ns	
t _{r1} /t _{f1}	Rise and fall time for output slew rate 1	V _{CCOUT} = 2.5 V (20%–80%)	1.8	2.9	4.4	ns	
t _{r2} /t _{f2}	Rise and fall time for output slew rate 2	V _{CCOUT} = 2.5 V (20%–80%)	1.3	2	3.2	ns	
t _{r3} /t _{f3}	Rise and fall time for output slew rate 3 (default configuration)	V _{CCOUT} = 2.5 V (20%–80%)	0.4	0.8	1.1	ns	
t _{jit(cc)}	Cycle-to-cycle jitter ⁽¹⁰⁾⁽¹¹⁾	1 PLL, 1 output	f _{OUT} = 50 MHz		60	105	ps
			f _{OUT} = 245.76 MHz		50	85	
		3 PLLs, 3 outputs	f _{OUT} = 50 MHz		130	160	
			f _{OUT} = 245.76 MHz		60	95	
t _{jit(per)}	Peak-to-peak period jitter ⁽¹⁰⁾⁽¹¹⁾	1 PLL, 1 output	f _{OUT} = 50 MHz		65	110	ps
			f _{OUT} = 245.76 MHz		60	90	
		3 PLLs, 3 outputs	f _{OUT} = 50 MHz		145	180	
			f _{OUT} = 245.76 MHz		70	105	
t _{sk(o)}	Output skew (see ⁽¹²⁾ and Table 5)	2-ns rise/fall time at f _{VCO} = 150 MHz, Pdiv = 3			250	ps	
odc	Output duty cycle ⁽¹³⁾	f _{VCO} = 100 MHz, Pdiv = 1	45%		55%		
SMBus PARAMETER							
V _{IK}	SCLK and SDATA input clamp voltage	V _{CC} = 3 V, I _I = –18 mA			–1.2	V	
I _{LK}	SCLK and SDATA input current	V _I = 0 V or V _{CC} , V _{CC} = 3.6 V			±5	μA	
V _{IH}	SCLK input, high voltage		2.1			V	
V _{IL}	SCLK input, low voltage				0.8	V	
V _{OL}	SDATA low-level output voltage	I _{OL} = 4 mA, V _{CC} = 3 V			0.4	V	
C _I	Input capacitance at SCLK	V _I = 0 V or V _{CC}		3	10	pF	
	Input capacitance at SDATA	V _I = 0 V or V _{CC}		3	10	pF	

(9) There is a limited drive capability at output supply voltage of 2.5 V. For proper termination, see the *CDCx706/x906 Termination and Signal Integrity Guidelines* application report, [SCAA080](#).

(10) 50,000 cycles

(11) Jitter depends on configuration. Jitter data is normal t_r/t_f, input frequency = 3.84 MHz, f_{VCO} = 245.76 MHz.

(12) The t_{sk(o)} specification is only valid for equal loading of all outputs.

(13) odc depends on output rise and fall time (t_r/t_f). The data is for normal t_r/t_f and is valid for both SSC on and off.

PARAMETER MEASUREMENT INFORMATION

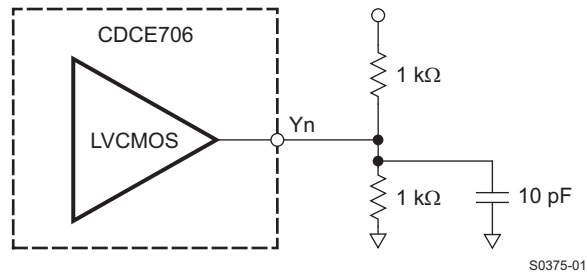
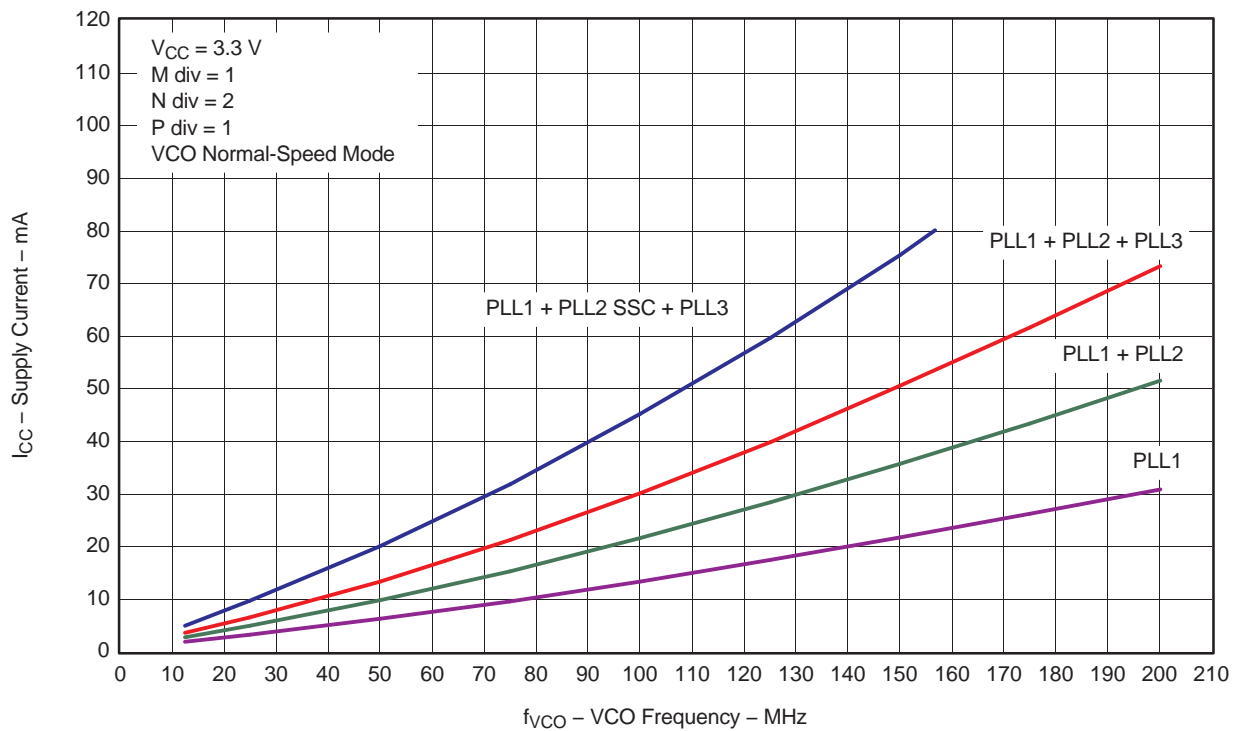

Figure 1. Test Load

TYPICAL CHARACTERISTICS



G001

Figure 2. I_{CC} vs Number of PLLs and VCO Frequency (VCO at Normal-Speed Mode, Byte 6 Bits [7:5])

TYPICAL CHARACTERISTICS (continued)

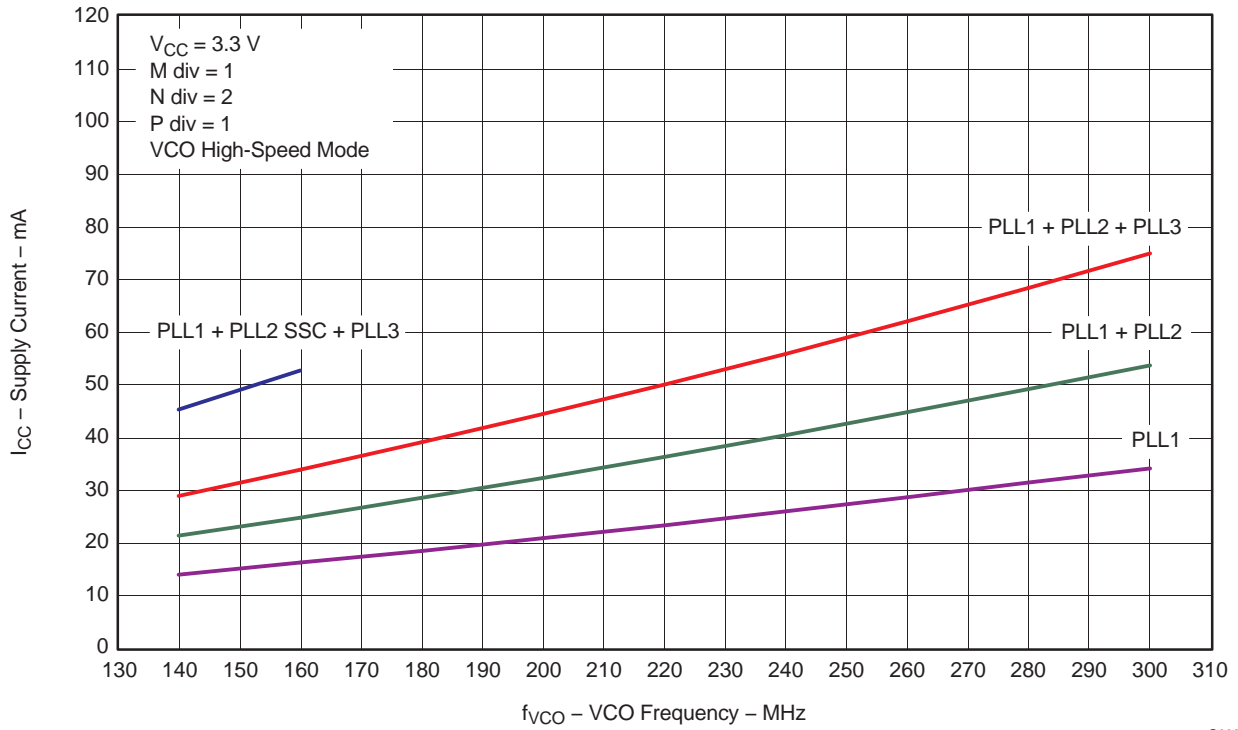

G002

Figure 3. I_{CC} vs Number of PLLs and VCO Frequency (VCO at High-Speed Mode, Byte 6 Bits [7:5])

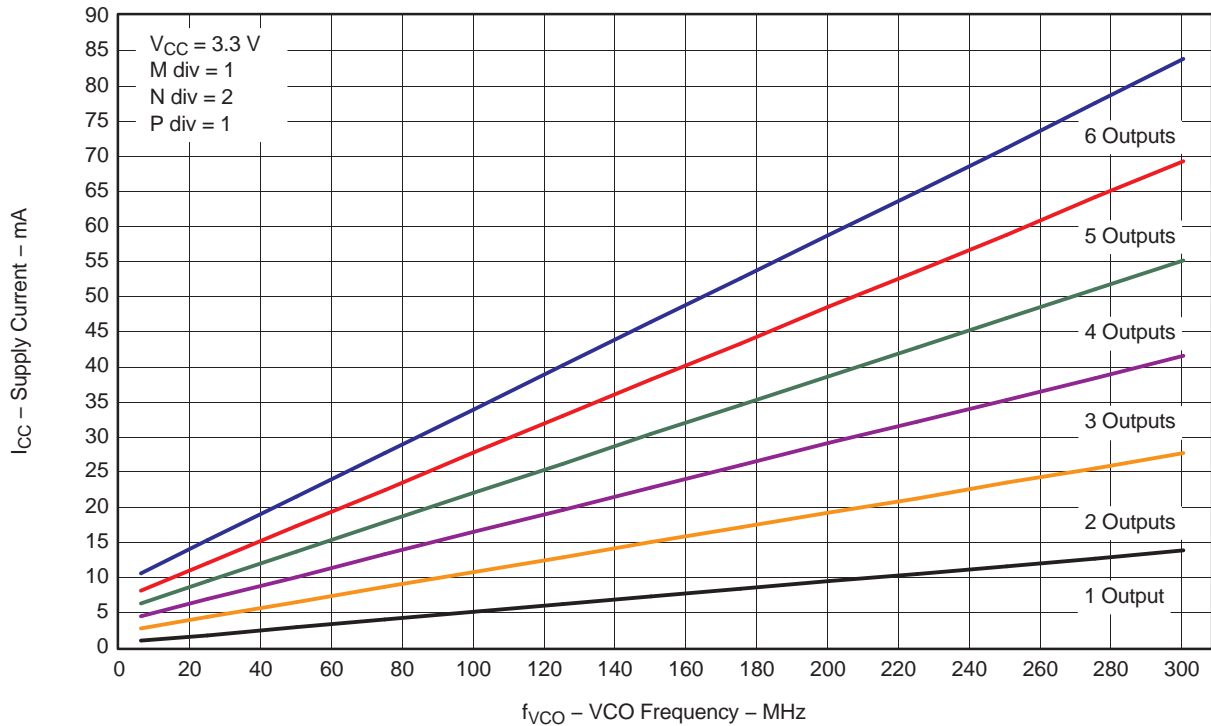

G003

Figure 4. I_{CCOUT} vs Number of Outputs and VCO Frequency

TYPICAL CHARACTERISTICS (continued)

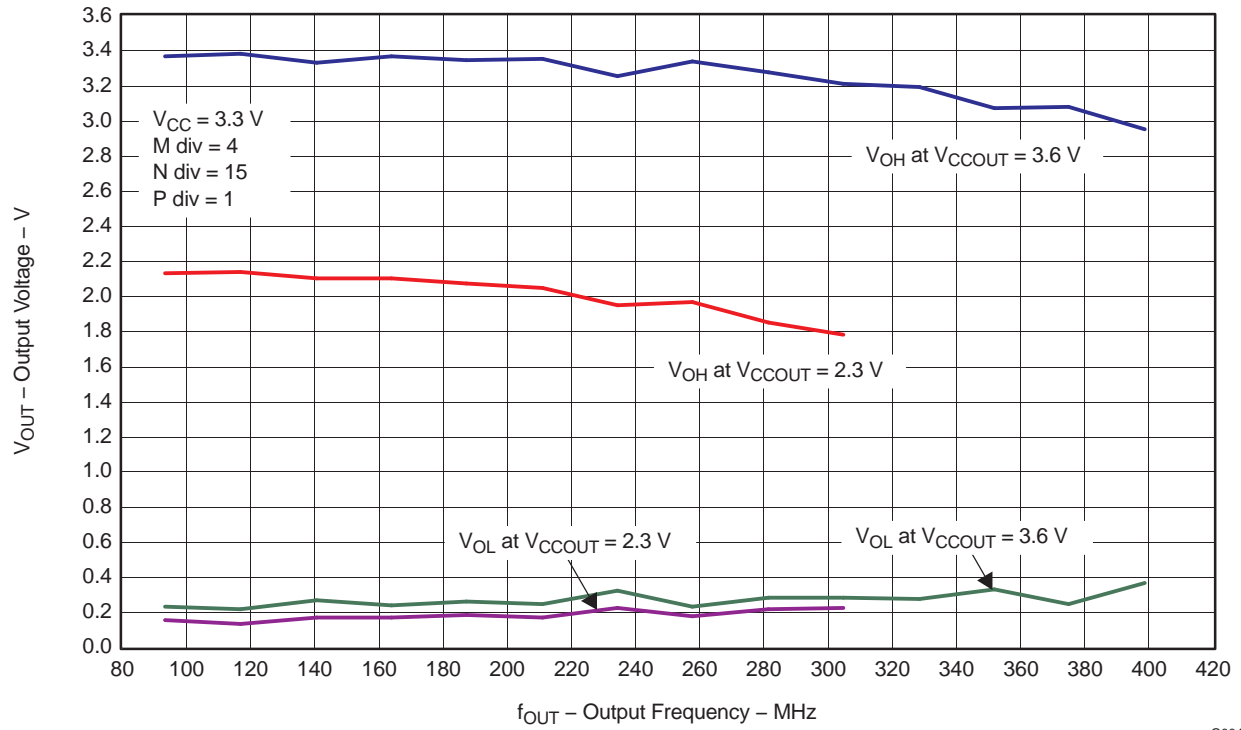

Figure 5. Output Swing vs Output Frequency

G004

APPLICATION INFORMATION

SMBus Data Interface

To enhance the flexibility and function of the clock synthesizer, a two-signal serial interface is provided. It follows the SMBus specification Version 2.0, which is based on the principles of operation of I²C. More details of the SMBus specification can be found at <http://www.smbus.org>.

Through the SMBus, various device functions, such as individual clock output buffers, can be individually enabled or disabled. The registers associated with the SMBus data interface initialize to their default setting on power up; therefore, using this interface is optional. The clock device register changes are normally made on system initialization, if any are required.

Data Protocol

The clock-driver serial protocol accepts byte-write, byte-read, block-write, and block-read operations from the controller.

For block-write/read operations, the bytes must be accessed in sequential order from lowest to highest byte (most significant bit first) with the ability to stop after any complete byte has been transferred. For byte-write and byte-read operations, the system controller can access individually addressed bytes.

Once a byte has been sent, it is written into the internal register and becomes effective immediately after the rising edge of the ACK bit. This applies to each transferred byte, independently of whether this is a byte-write or a block-write sequence.

If the EEPROM write cycle is initiated, the data of the internal SMBus register is written into the EEPROM. During EEPROM write, no data is allowed to be sent to the device via the SMBus until the programming sequence is completed. Data, however, can be read out during the programming sequence (byte read or block read). The programming status can be monitored by EEPIP, byte 24 bit 7.

The offset of the indexed byte is encoded in the command code, as described in [Table 1](#).

The block-write and block-read protocol is outlined in [Figure 9](#) and [Figure 10](#), whereas [Figure 7](#) and [Figure 8](#) outline the corresponding byte-write and byte-read protocol.

Slave Receiver Address (7 bits)

A6	A5	A4	A3	A2	A1 ⁽¹⁾	A0 ⁽¹⁾	\bar{R}/W
1	1	0	1	0	0	1	0

(1) Address bits A0 and A1 are programmable by the configuration inputs S0 and S1 (byte 10 bits [1:0] and bits [3:2]). This allows addressing up to four devices connected to the same SMBus.

Table 1. Command Code Definition

Bits	Description
7	0 = Block-read or block-write operation 1 = Byte-read or byte-write operation
6–0	Byte offset for read and write operations

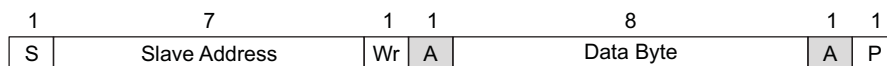

- S Start Condition
- Sr Repeated Start Condition
- Rd Read (Bit Value = 1)
- Wr Write (Bit Value = 0)
- A Acknowledge (ACK = 0 and NACK = 1)
- P Stop Condition
- PE Packet Error
- Master-to-Slave Transmission
- Slave-to-Master Transmission

M0053-01

Figure 6. Generic Programming Sequence

Byte-Write Programming Sequence

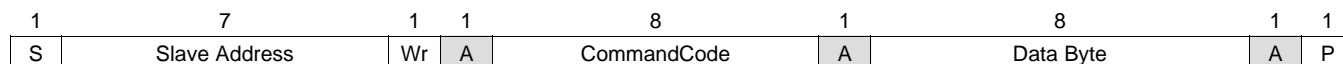

Figure 7. Byte-Write Protocol

Byte-Read Programming Sequence

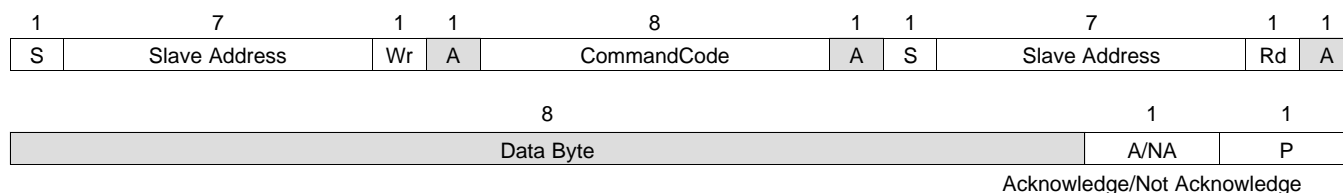
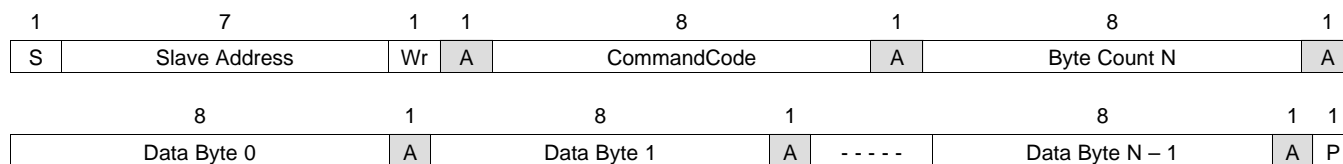

Figure 8. Byte-Read Protocol

Block-Write Programming Sequence⁽¹⁾



(1) Data Byte 0 is reserved for revision code and vendor identification. However, this byte is used for internal test. Do not write into it other than 0000 0001.

Figure 9. Block-Write Protocol

Block-Read Programming Sequence

1	7	1	1	8	1	1	7	1	1
S	Slave Address	Wr	A	CommandCode	A	Sr	Slave Address	Rd	A
8	1	8	1	-----	8	1	1		
Byte Count N	A	Data Byte 0	A		Data Byte N - 1	NA	P		

Figure 10. Block-Read Protocol

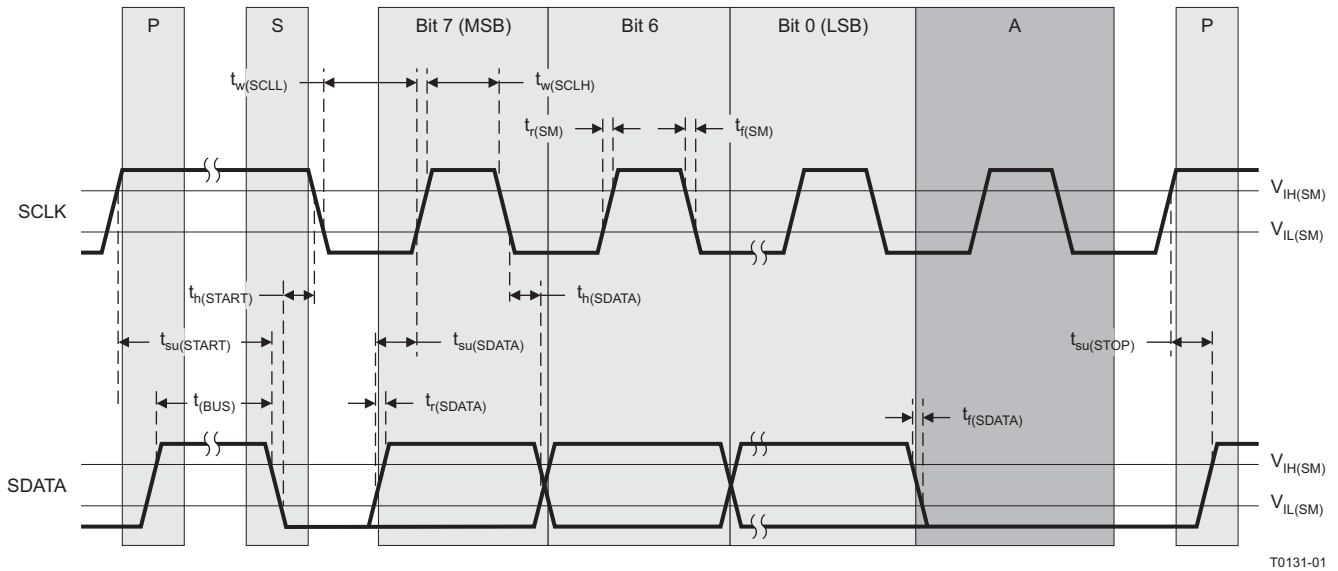

Figure 11. Timing Diagram, Serial Control Interface

SMBus Hardware Interface

Figure 12 shows how the CDCE706 clock synthesizer is connected to the SMBus. Note that the current through the pullup resistors (R_p) must meet the SMBus specifications (minimum 100 μ A, maximum 350 μ A). If the CDCE706 is not connected to the SMBus, the SDATA and SCLK inputs must be connected with 10-k Ω resistors to V_{CC} to avoid floating input conditions.

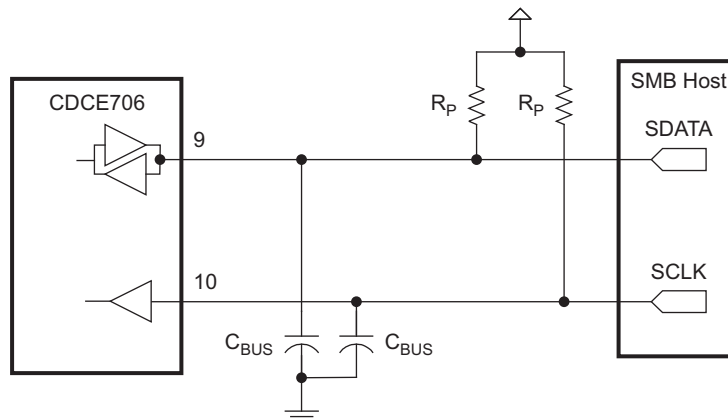

Figure 12. SMBus Hardware Interface

Table 2. Register Configuration Command Bitmap

Adr	Bit 7	Bit 6	Bit 5	Bit 4	Bit 3	Bit 2	Bit 1	Bit 0
Byte 0	Revision Code				Vendor Identification			
Byte 1	PLL1 Reference Divider M 9-Bit [7:0]							
Byte 2	PLL1 Feedback Divider N 12-Bit [7:0]							
Byte 3	PLL1 Mux	PLL2 Mux	PLL3 Mux	PLL1 Feedback Divider N 12-Bit [11:8]			PLL1 Ref Div M [8]	
Byte 4	PLL2 Reference Divider M 9-Bit [7:0]							
Byte 5	PLL2 Feedback Divider N 12-Bit [7:0]							
Byte 6	PLL1 f_{VCO} Selection	PLL2 f_{VCO} Selection	PLL3 f_{VCO} Selection	PLL2 Feedback Divider N 12-Bit [11:8]			PLL2 Ref Div M [8]	
Byte 7	PLL3 Reference Divider 9-Bit M [7:0]							
Byte 8	PLL3 Feedback Divider N [12-Bit 7:0]							
Byte 9	PLL Selection for P0 (Switch A)			PLL3 Feedback Divider N 12-Bit [11:8]			PLL3 Ref Div M [8]	
Byte 10	PLL Selection for P1 (Switch A)			Inp. Clock Selection	Configuration Inputs S1	Configuration Inputs S0		
Byte 11	Input Signal Source		PLL Selection for P3 (Switch A)		PLL Selection for P2 (Switch A)			
Byte 12	Reserved	Power Down	PLL Selection for P5 (Switch A)		PLL Selection for P4 (Switch A)			
Byte 13	Reserved	7-Bit Divider P0 [6:0]						
Byte 14	Reserved	7-Bit Divider P1 [6:0]						
Byte 15	Reserved	7-Bit Divider P2 [6:0]						
Byte 16	Reserved	7-Bit Divider P3 [6:0]						
Byte 17	Reserved	7-Bit Divider P4 [6:0]						
Byte 18	Reserved	7-Bit Divider P5 [6:0]						
Byte 19	Reserved	Y0 Inv. or Non-Inv	Y0 Slew-Rate Control	Y0 Enable or Low	Y0 Divider Selection (Switch B)			
Byte 20	Reserved	Y1 Inv. or Non-Inv	Y1 Slew-Rate Control	Y1 Enable or Low	Y1 Divider Selection (Switch B)			
Byte 21	Reserved	Y2 Inv. or Non-Inv	Y2 Slew-Rate Control	Y2 Enable or Low	Y2 Divider Selection (Switch B)			
Byte 22	Reserved	Y3 Inv. or Non-Inv	Y3 Slew-Rate Control	Y3 Enable or Low	Y3 Divider Selection (Switch B)			
Byte 23	Reserved	Y4 Inv. or Non-Inv	Y4 Slew-Rate Control	Y4 Enable or Low	Y4 Divider Selection (Switch B)			
Byte 24	EEPIP [read only]	Y5 Inv or Non-Inv	Y5 Slew-Rate Control	Y5 Enable or Low	Y5 Divider Selection (Switch B)			
Byte 25	EELOCK	SSC Modulation Selection			Frequency Selection for SSC			
Byte 26	EEWRITE	7-Bit Byte Count						

Default Device Setting

The internal EEPROM of the CDCE706 is preprogrammed with a factory-default configuration as shown in [Figure 13](#). This puts the device in an operating mode without the need to program it first. The default setting appears after power is switched on or after a power-down/up sequence until it is reprogrammed by the user to a different application configuration. A new register setting is programmed via the serial SMBus Interface.

A different default setting can be programmed on customer request. Contact a Texas Instruments Sales and Marketing representative for more information.

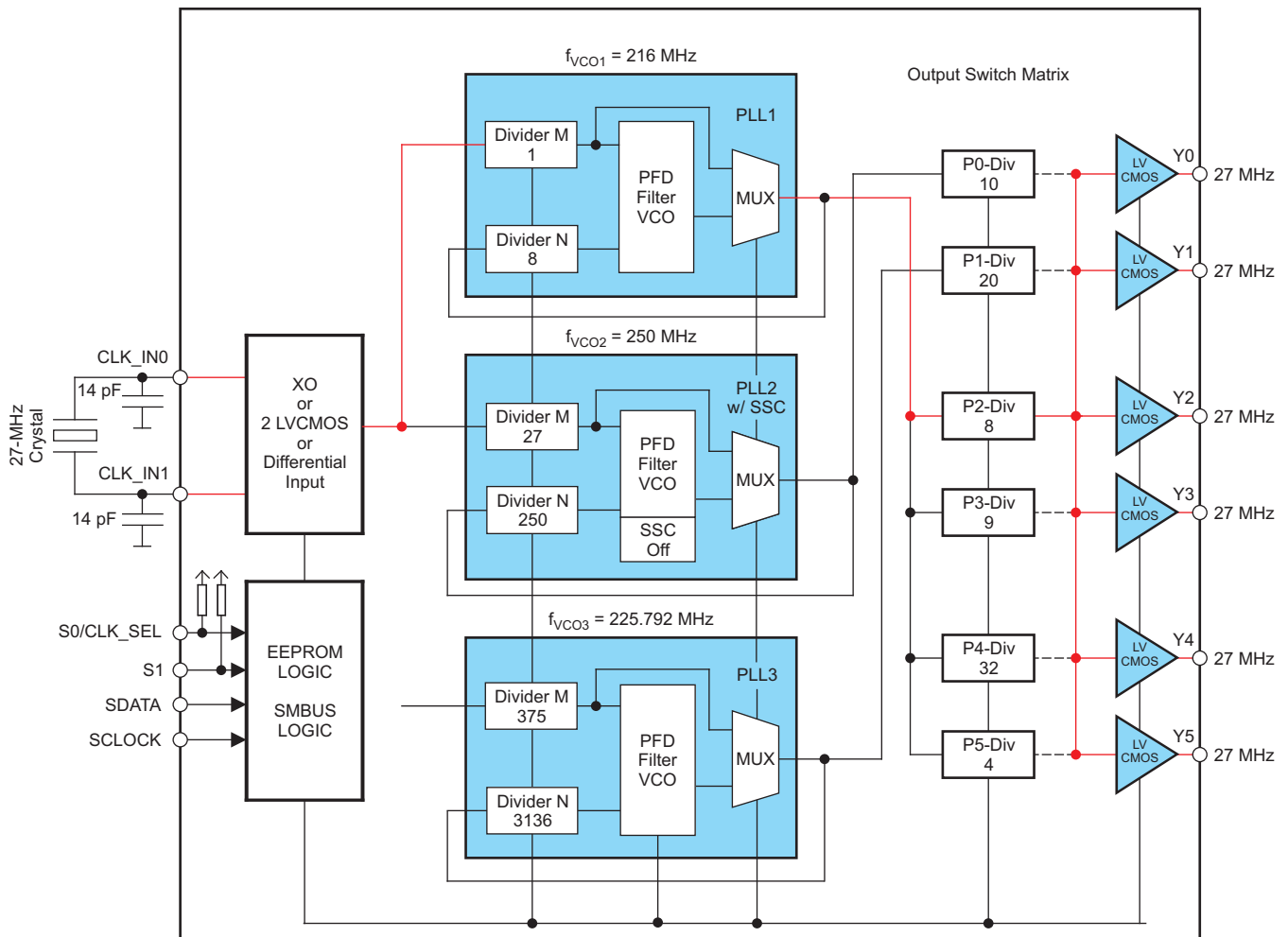

B0336-01

NOTE: All outputs are enabled and in noninverting mode. S0, S1, and SSC comply according the default setting described in byte 10 and byte 25.

Figure 13. Default Device Setting

The output frequency can be calculated:

$$f_{out} = \frac{f_{in} \times N}{M \times P}, \text{ i.e., } f_{out} = \frac{27 \text{ MHz} \times 8}{(1 \times 8)} = 27 \text{ MHz}$$

(1)

Functional Description of the Logic

All bytes are readable/writeable, unless otherwise expressly mentioned.

Byte 0 (Read-Only): Vendor Identification Bits [3:0]; Revision Code Bit [7:4] ⁽¹⁾								
Revision Code				Vendor Identification				
X	X	X	X	0	0	0	1	

(1) Byte 0 is only readable by the byte-read instruction (see [Figure 8](#)).

Bytes 1 to 9: Reference Divider M of PLL1, PLL2, PLL3 ⁽¹⁾										
M8	M7	M6	M5	M4	M3	M2	M1	M0	Div by	Default ^{(2) (3)}
0	0	0	0	0	0	0	0	0	Not allowed	
0	0	0	0	0	0	0	0	1	1	
0	0	0	0	0	0	0	1	0	2	
0	0	0	0	0	0	0	1	1	3	
				•						
				•						
1	1	1	1	1	1	1	0	1	509	
1	1	1	1	1	1	1	1	0	510	
1	1	1	1	1	1	1	1	1	511	

(1) By selecting the PLL divider factors, $M \leq N$ and $80 \text{ MHz} \leq f_{VCO} \leq 300 \text{ MHz}$.

(2) Unless customer-specific setting

(3) Default setting of divider M for PLL1 = 1, for PLL2 = 27, and for PLL3 = 375.

Bytes 1 to 9: Feedback Divider N of PLL1, PLL2, PLL3 ⁽¹⁾													
N11	N10	N9	N8	N7	N6	N5	N4	N3	N2	N1	N0	Div by	Default ^{(2) (3)}
0	0	0	0	0	0	0	0	0	0	0	0	Not allowed	
0	0	0	0	0	0	0	0	0	0	0	1	1	
0	0	0	0	0	0	0	0	0	0	1	0	2	
0	0	0	0	0	0	0	0	0	0	1	1	3	
							•						
							•						
1	1	1	1	1	1	1	1	1	1	0	1	4093	
1	1	1	1	1	1	1	1	1	1	1	0	4094	
1	1	1	1	1	1	1	1	1	1	1	1	4095	

(1) By selecting the PLL divider factors, $M \leq N$ and $80 \text{ MHz} \leq f_{VCO} \leq 300 \text{ MHz}$.

(2) Unless customer-specific setting

(3) Default setting of divider N for PLL1 = 8, for PLL2 = 250, and for PLL3 = 3136.

Byte 3 Bits [7:5]: PLL (VCO) Bypass Multiplexer		
PLLxMUX	PLL (VCO) MUX Output	Default ⁽¹⁾
0	PLLx	Yes
1	VCO bypass	

(1) Unless customer-specific setting

Byte 6 Bits [7:5]: VCO Frequency Selection Mode for Each PLL ⁽¹⁾		
PLLxVFCO	VCO Frequency Range	Default ⁽²⁾
0	80 MHz–200 MHz	
1	180 MHz–300 MHz	Yes

(1) This bit selects the normal-speed mode or the high-speed mode for the dedicated VCO in PLL1, PLL2, or PLL3. At power up, the high-speed mode is selected, f_{VCO} is 180 MHz–300 MHz. In case of a higher f_{VCO} , this bit must be set to 1.

(2) Unless customer-specific setting

Bytes 9 to 12: Output Switch Matrix (5 × 6 Switch A) PLL Selection for P-Divider P0–P5				
SWAPx2	SWAPx1	SWAPx0	Any Output Px	Default ⁽¹⁾
0	0	0	PLL bypass (input clock)	
0	0	1	PLL1	P2, P3, P4, P5
0	1	0	PLL2 non-SSC	P0
0	1	1	PLL2 with SSC ⁽²⁾	
1	0	0	PLL3	P1
1	0	1	Reserved	
1	1	0	Reserved	
1	1	1	Reserved	

(1) Unless customer-specific setting

(2) PLL2 has an SSC output and a non-SSC output. If SSC bypass is selected (see byte 25, bits [6:4]), the SSC circuitry of PLL2 is powered down and the SSC output is reset to logic low. The non-SSC output of PLL2 is not affected by this mode and can still be used.

Byte 10, Bits [1:0]: Configuration Settings of Input S0/A0/CLK_SEL			
S01	S00	Function	Default ⁽¹⁾
0	0	If S0 is low, the PLLs and the clock-input stage go into power-down mode, outputs are in the high-impedance state, all actual register settings are maintained, SMBus stays active. If S0 is high, then the device is powered on and outputs are active. ⁽²⁾	Yes
0	1	If S0 is low, the PLL and all dividers (M-Div and P-Div) are bypassed and PLL is in power down, all outputs are active (inv. or non-inv.), actual register settings are maintained, SMBus stays active; this mode is useful for production test. If S0 is high, then the device is powered on and outputs are active.	
1	0	CLK_SEL (input clock selection—overwrites the CLK_SEL setting in byte 10, bit [4]) ⁽³⁾ —CLK_SEL when set low selects CLK_IN_IN0. —CLK_SEL when set high selects CLK_IN_IN1.	
1	1	In this mode, the control input S0 is interpreted as address bit A0 of the slave receiver address byte ⁽⁴⁾ .	

(1) Unless customer-specific setting

(2) Power-down mode overwrites the high-impedance state or low state of the S1 setting in byte 10, bits [3:2].

(3) If the clock input (CLK_IN0/CLK_IN1) is selected as crystal input or differential clock input (byte 11, bits [7:6]), then this setting is not relevant.

(4) To use this pin as slave receiver address bit A0, an initialization pattern must be sent to the CDCE706. When S00/S01 is set to 1, the S0 input pin is interpreted in the next read or write cycle as address bit A0 of the slave receiver address byte. Note that right after byte 10 (S00/S01) has been written, A0 (via the S0-pin) is immediately active (also when byte 10 is sent within a block-write sequence). After the initialization, each CDCE706 has its own S0-dependent slave receiver address and can be addressed according to its new valid address.

Byte 10, Bits [3:2]: Configuration Settings of Input S1/A1			
S11	S10	Function	Default ⁽¹⁾
0	0	If S1 is set low, all outputs are switched to a low-state (non-inv.) or high-state (inv.). If S1 is high, then all the outputs are active.	Yes
0	1	If S1 is set low, all outputs are switched to a high-impedance state. If S1 is high, then all the outputs are active.	
1	0	Reserved	
1	1	In this mode, control input S1 is interpreted as address bit A1 of the slave receiver address byte. ⁽²⁾	

(1) Unless customer-specific setting

(2) To use this pin as slave-receiver address bit A1, an initialization pattern must be sent to the CDCE706. When S10/S11 is set to be 1, the S1 input pin is interpreted in the next read or write cycle as address bit A1 of the slave receiver address byte. Note that right after byte 10 (S10/S11) has been written, A1 (via the S1-pin) is immediately active (also when byte 10 is sent within a block-write sequence). After the initialization, each CDCE706 has its own S1-dependent slave receiver address and can be addressed according to its new valid address.

Byte 10, Bit [4]: Input Clock Selection ⁽¹⁾		
CLKSEL	Input Clock	Default ⁽²⁾
0	CLK_IN0	Yes
1	CLK_IN1	

(1) This bit is not relevant if crystal input or differential clock input is selected, byte 11, bits [7:6].

(2) Unless customer-specific setting

Byte 11, Bits [7:6]: Input Signal Source ⁽¹⁾			
IS1	IS0	Function	Default ⁽²⁾
0	0	CLK_IN0 is the crystal oscillator input, and CLK_IN1 serves as the crystal oscillator output.	Yes
0	1	CLK_IN0 and CLK_IN1 are two LVCMOS inputs. CLK_IN0 or CLK_IN1 is selectable via the CLK_SEL control pin.	
1	0	CLK_IN0 and CLK_IN1 serve as differential signal inputs.	
1	1	Reserved	

(1) In case the crystal input or differential clock input is selected, the input clock selection, byte 10, bit [4], is not relevant.

(2) Unless customer-specific setting

Byte 12, Bit [6]: Power-Down Mode (Except SMBus)		
PD	Power-Down Mode	Default ⁽¹⁾
0	Normal device operation	Yes
1	Power down ⁽²⁾	

(1) Unless customer-specific setting

(2) In power down, all PLLs and the clock-input stage go into power-down mode, all outputs are in the high-impedance state, all actual register settings are maintained, and the SMBus stays active. The power-down mode overwrites the high-impedance state or low state of the S0 and S1 settings in byte 10.

Bytes 13 to 18, Bit [6:0]: Outputs Switch Matrix 6 × 7-Bit Divider P0–P5								
DIVYx6	DIVYx5	DIVYx4	DIVYx3	DIVYx2	DIVYx1	DIVYx0	Div by	Default ⁽¹⁾⁽²⁾
0	0	0	0	0	0	0	Not allowed	
0	0	0	0	0	0	1	1	
0	0	0	0	0	1	0	2	
		•						
		•						
		•						
1	1	1	1	1	0	1	125	
1	1	1	1	1	1	0	126	
1	1	1	1	1	1	1	127	

(1) Unless customer-specific setting

(2) Default settings of divider P0 = 10, P1 = 20, P2 = 8, P3 = 9, P4 = 32, and P5 = 4.

Bytes 19 to 24, Bits [5:4]: LVCMOS Output Rise/Fall Time Setting at Y0–Y5			
SRCYx1	SRCYx0	Yx	Default ⁽¹⁾
0	0	Nominal +3 ns (t_{r0}/t_{f0})	
0	1	Nominal +2 ns (t_{r1}/t_{f1})	
1	0	Nominal +1 ns (t_{r2}/t_{f2})	
1	1	Nominal (t_{r3}/t_{f3})	Yes

(1) Unless customer-specific setting

Bytes 19 to 24, Bits [2:0]: Outputs Switch Matrix (6 × 6 Switch B) Divider (P0–P5) Selection for Outputs Y0–Y5				
SWBYx2	SWBYx1	SWBYx0	Any Output Yx	Default ⁽¹⁾
0	0	0	Divider P0	
0	0	1	Divider P1	
0	1	0	Divider P2	Y0, Y1, Y2, Y3, Y4, Y5
0	1	1	Divider P3	
1	0	0	Divider P4	
1	0	1	Divider P5	
1	1	0	Reserved	
1	1	1	Reserved	

(1) Unless customer-specific setting

Bytes 19 to 24, Bit [3]: Output Y0–Y5 Enable or Low-State		
ENDISYx	Output Yx	Default ⁽¹⁾
0	Disable to low	
1	Enable	Yes

(1) Unless customer-specific setting

Bytes 19 to 24, Bit [6]: Output Y0–Y5 Noninverting/Inverting		
INVIYx	Output Yx Status	Default ⁽¹⁾
0	Noninverting	Yes
1	Inverting	

(1) Unless customer-specific setting

Byte 24, Bit [7] (Read-Only): EEPROM Programming In Process Status ⁽¹⁾		
EEPIP	Indicate EEPROM Write Process	Default
0	No programming	
1	Programming in process	

(1) This *read-only* bit indicates an EEPROM write process. It is set to high if programming starts and resets to low if programming is completed. Any data written to the EEPIP bit is ignored. During programming, no data are allowed to be sent to the device via the SMBus until the programming sequence is completed. Data, however, can be read out during the programming sequence (byte read or block read).

Byte 25, Bits [3:0]: SSC Modulation Frequency Selection in the Range of 30 kHz to 60 kHz ⁽¹⁾														
FSSC3	FSSC2	FSSC1	FSSC0	Modulation Factor	f_{mod} [kHz]	f_{vco} (MHz)							Default ⁽²⁾	
						100	110	120	130	140	150	160		167
0	0	0	0	5680		17.6	19.4	21.1	22.9	24.6	26.4	28.2	29.4	
0	0	0	1	5412		18.5	20.3	22.2	24.0	25.9	27.7	29.6	30.9	
0	0	1	0	5144		19.4	21.4	23.3	25.3	27.2	29.2	31.1	32.5	
0	0	1	1	4876		20.5	22.6	24.6	26.7	28.7	30.8	32.8	34.2	
0	1	0	0	4608		21.7	23.9	26.0	28.2	30.4	32.6	34.7	36.2	
0	1	0	1	4340		23.0	25.3	27.6	30.0	32.3	34.6	36.9	38.5	
0	1	1	0	4072		24.6	27.0	29.5	31.9	34.4	36.8	39.3	41.0	
0	1	1	1	3804		26.3	28.9	31.5	34.2	36.8	39.4	42.1	43.9	
1	0	0	0	3536		28.3	31.1	33.9	36.8	39.6	42.4	45.2	47.2	
1	0	0	1	3286		30.4	33.5	36.5	39.6	42.6	45.6	48.7	50.8	Yes
1	0	1	0	3000		33.3	36.7	40.0	43.3	46.7	50.0	53.3	55.7	
1	0	1	1	2732		36.6	40.3	43.9	47.6	51.2	54.9	58.6	61.1	
1	1	0	0	2464		40.6	44.6	48.7	52.8	56.8	60.9	64.9	67.8	
1	1	0	1	2196		45.5	50.1	54.6	59.2	63.8	68.3	72.9	76.0	
1	1	1	0	1928		51.9	57.1	62.2	67.4	72.6	77.8	83.0	86.6	
1	1	1	1	1660		60.2	66.3	72.3	78.3	84.3	90.4	96.4	100.6	

(1) The PLL must be bypassed (turned off) when changing the *SSC Modulation Frequency Factor* on-the-fly. This can be done by the following programming sequence: bypass PLL2 (byte 3, bit 6 = 1); write new *Modulation Factor* (byte 25); re-activate PLL2 (byte 3, bit 6 = 0).

(2) Unless customer-specific setting

Byte 25, Bits [6:4]: SSC Modulation Amount ⁽¹⁾				
SSC2	SSC1	SSC0	Function	Default ⁽²⁾
0	0	0	SSC modulation amount 0% = SSC bypass for PLL ⁽³⁾	Yes
0	0	1	SSC modulation amount $\pm 0.1\%$ (center spread)	
0	1	0	SSC modulation amount $\pm 0.25\%$ (center spread)	
0	1	1	SSC modulation amount $\pm 0.4\%$ (center spread)	
1	0	0	SSC modulation amount 1% (down spread)	
1	0	1	SSC modulation amount 1.5% (down spread)	
1	1	0	SSC modulation amount 2% (down spread)	
1	1	1	SSC modulation amount 3% (down spread)	

- (1) The PLL must be bypassed (turned off) when changing SSC Modulation Amount on-the-fly. This can be done by the following programming sequence: bypass PLL2 (byte 3, bit 6 = 1); write new Modulation Amount (byte 25); re-activate PLL2 (byte 3, bit 6 = 0).
- (2) Unless customer-specific setting
- (3) If SSC bypass is selected, the SSC circuitry of PLL2 is powered down and the SSC output is reset to logic low. The non-SSC output of PLL2 is not affected by this mode and can still be used.

Byte 25, Bit [7]: Permanently Lock EEPROM Data		
EELOCK	Permanently Lock EEPROM ⁽¹⁾	Default ⁽²⁾
0	No	Yes
1	Yes	

- (1) If this bit is set, the actual data in the EEPROM is permanently locked. Note that the EEPROM lock becomes effective when this bit is set in the EEPROM and not in the internal volatile register. No further programming is possible, even if this bit is set low. Data, however can still be written via SMBUS to the internal register to change device function on the fly. But new data no longer can be stored into the EEPROM.
- (2) Unless customer-specific setting

Byte 26, Bits [6:0]: Byte Count ⁽¹⁾								
BC6	BC5	BC4	BC3	BC2	BC1	BC0	No. of Bytes	Default ⁽²⁾
0	0	0	0	0	0	0	Not allowed	
0	0	0	0	0	0	1	1	
0	0	0	0	0	1	0	2	
0	0	0	0	0	1	1	3	
			•					
			•					
			•					
0	0	1	1	0	1	1	27	Yes
			•					
			•					
			•					
1	1	1	1	1	0	1	125	
1	1	1	1	1	1	0	126	
1	1	1	1	1	1	1	127	

- (1) Defines the number of bytes, which is sent from this device at the next block-read protocol.
- (2) Unless customer-specific setting

Byte 26, Bit [7]: Initiate EEPROM Write Cycle ⁽¹⁾		
EEWRITE	Starts EEPROM Write Cycle	Default ⁽²⁾
0	No	Yes
1	Yes	

- (1) The EEPROM WRITE cycle is initiated with the rising edge of the EEWRITE bit. The EEPROM WRITE bit must be sent last to ensure that the content of all internal registers is stored in the EEPROM. Do not interrupt the EEPROM WRITE cycle; otherwise, random data can be stored in the EEPROM. A static level-high does not trigger an EEPROM WRITE cycle. This bit stays high until the user resets it to low (it is not automatically reset after the programming has been completed). Therefore, to initiate an EEPROM WRITE cycle, it is recommended to send a zero-one sequence to the EEWRITE bit in byte 26.
- During EEPROM programming, no data are allowed to be sent to the device via the SMBus until the programming sequence has been completed. Data, however, can be read out during the programming sequence (byte read or block read). The programming status can be monitored by reading out EEPIP, byte 24, bit 7. If EELOCK is set, no EEPROM programming is possible.
- (2) Unless customer-specific setting

FUNCTIONAL DESCRIPTION

Clock Inputs (CLK_IN0 and CLK_IN1)

The CDCE706 features two clock inputs which can be used as:

- Crystal oscillator input (default setting)
- Two independent single-ended LVCMOS inputs
- Differential signal input

The dedicated clock input can be selected by the *input signal source* bits [7:6] of byte 11.

Crystal Oscillator Inputs

The input frequency range in crystal mode is 8 MHz to 54 MHz. The CDCE706 uses Pierce-type oscillator circuitry with included feedback resistance for the inverting amplifier. The user, however, must add external capacitors (C_{X0} , C_{X1}) to match the input load capacitor from the crystal (see Figure 14). The required values can be calculated:

$$C_{X0} = C_{X1} = 2 \times C_L - C_{ICB},$$

where C_L is the crystal load capacitor as specified for the crystal unit and C_{ICB} is the input capacitance of the device, including the board capacitance (stray capacitance of PCB).

For example, for a fundamental 27-MHz crystal with C_L of 9 pF and C_{ICB} of 4 pF,

$$C_{X0} = C_{X1} = (2 \times 9 \text{ pF}) - 3 \text{ pF} = 15 \text{ pF}.$$

It is important to use a short PCB trace from the device to the crystal unit to keep the stray capacitance of the oscillator loop to a minimum.

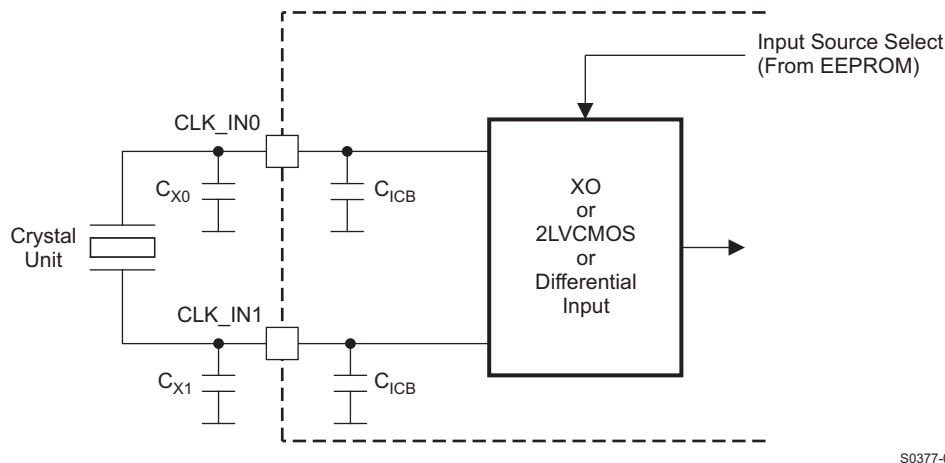

S0377-01

Figure 14. Crystal Input Circuitry

In order to ensure stable oscillation, a certain drive power must be applied. The CDCE706 features an input oscillator with adaptive gain control, which relieves the user of manually programming the gain. Additionally, adaptive gain control eliminates the use of external resistors to compensate the ESR of the crystal. The drive level is the amount of power dissipated by the oscillating crystal unit and is usually specified in terms of power dissipated by the resonator (equivalent series resistance (ESR)). Figure 15 gives the resulting drive level vs crystal frequency and ESR.

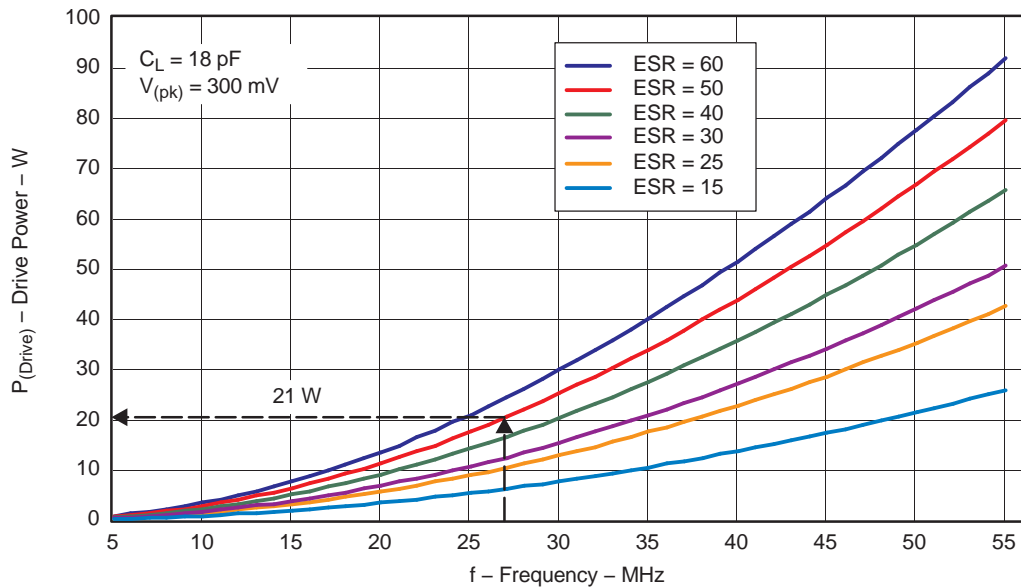

Figure 15. Crystal Drive Power

For example, if a 27-MHz crystal with ESR of 50 Ω is used and $2 \times C_L$ is 18 pF, the drive power is 21 μW. Drive level should be held to a minimum to avoid overdriving the crystal. The maximum power dissipation is specified for each type of crystal in the oscillator specifications, i.e., 100 μW for the example above.

Single-Ended LVCMOS Clock Inputs

When selecting the LVCMOS clock mode, CLK_IN0 and CLK_IN1 act as regular clock input pins and can be driven up to 200 MHz. Both clock input circuits are equal in design and can be used independently of each other (see Figure 16). The internal clock select bit, byte 10, bit [4], selects one of the two input clocks. CLK_IN0 is the default selection. There is also the option to program the external control pin S0/A0/CLK_SEL as the clock-select pin, byte 10, bits [1:0].

The two clock inputs can be used for redundancy switching, i.e., to switch between a primary clock and secondary clock. Note that a phase difference between the clock inputs may require PLL correction. Also, in case of different frequencies between the primary and secondary clock, the PLL must re-lock to the new frequency.

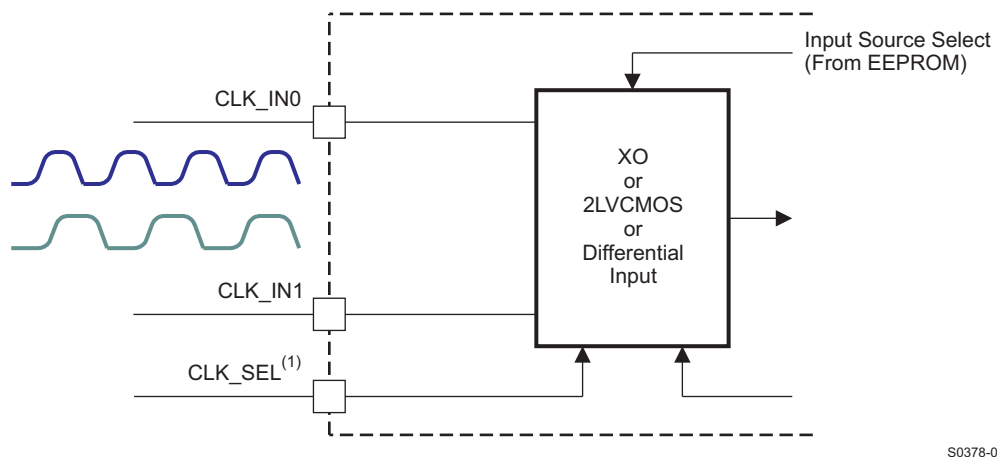

(1) CLK_SEL is optional and can be configured by EEPROM setting.

Figure 16. LVCMOS Clock Input Circuitry

Differential Clock Inputs

The CDCE706 supports differential signaling as well. In this mode, the CLK_IN0 and CLK_IN1 pins serve as differential signal inputs and can be driven up to 200 MHz.

The minimum magnitude of the differential input voltage is 100 mV over a differential common-mode input voltage range of 200 mV to $V_{CC} - 0.6$ V. If LVDS or LVPECL signal levels are applied, ac coupling and a biasing structure are recommended to adjust the different physical layers (see Figure 17). The capacitor removes the dc component of the signal (common-mode voltage), whereas the ac component (voltage swing) is passed on. A resistor pullup and/or pulldown network represents the biasing structure used to set the common-mode voltage on the receiver side of the ac-coupling capacitor. DC coupling is also possible.

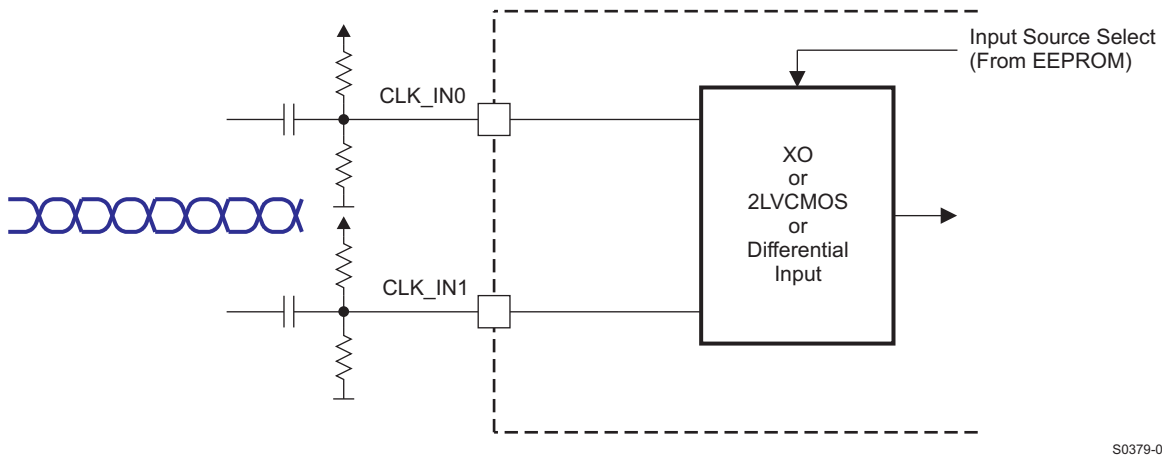

Figure 17. Differential Clock Input Circuitry

PLL Configuration and Setting

The CDCE706 includes three PLLs which are equal in function and performance, except PLL2, which in addition supports spread-spectrum clocking (SSC) generation. Figure 18 shows the block diagram of the PLL.

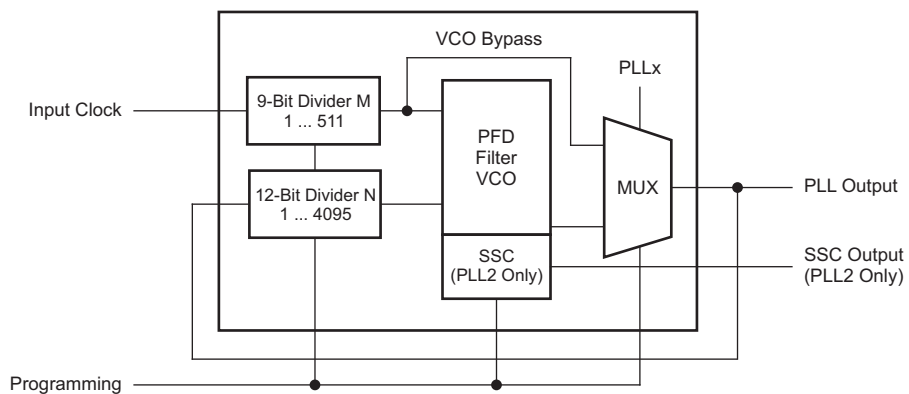

Figure 18. PLL Architecture

All three PLLs are designed for easiest configuration. The user must define only the input and output frequencies or the divider (M, N, P) setting. All other parameters, such as charge-pump current, filter components, phase margin, or loop bandwidth are controlled and set by the device itself. This assures optimized jitter attenuation and loop stability.

The PLLs supports normal-speed mode ($80 \text{ MHz} \leq f_{VCO} \leq 200 \text{ MHz}$) and high-speed mode ($180 \text{ MHz} \leq f_{VCO} \leq 300 \text{ MHz}$), which can be selected by PLLxFVCO (bits [7:5] of byte 6). The speed option assures stable operation and lowest jitter.

Divider M and divider N operate internally as a fractional divider for f_{VCO} up to 250 MHz. This allows a fractional divider ratio for zero-ppm output clock error.

In the case of $f_{VCO} > 250$ MHz, it is recommended that only integer factors of N/M are used.

For optimized jitter performance, keep divider M as small as possible. Also, the fractional divider concept requires a PLL divider configuration, $M \leq N$ (or $N/M \geq 1$).

Additionally, each PLL supports two bypass options:

- PLL bypass
- VCO bypass

In PLL bypass mode, the PLL is completely bypassed, so that the input clock is switched directly to output switch A (SWAPxx of bytes 9 to 12). In the VCO bypass mode, only the VCO of the PLL is bypassed by setting PLLxMUX to 1 (bits [7:5] of byte 3). But divider M still is useable and expands the output divider by an additional 9 bits. This gives a total divider range of $M \times P = 511 \times 127 = 64,897$. In VCO bypass mode, the PLL block is powered down and minimizes current consumption.

Table 3. Example for Divide, Multiplication, and Bypass Operation

Function	Equation ⁽¹⁾	f_{IN} [MHz]	$f_{OUT-desired}$ [MHz]	$f_{OUT-actual}$ [MHz]	Divider				f_{VCO} [MHz]
					M	N	P	N/M	
Fractional ⁽²⁾	$f_{OUT} = f_{IN} \times (N/M)/P$	30.72	155.52	155.52	16	81	1	5.0625	155.52
Integer factor ⁽³⁾	$f_{OUT} = f_{IN} \times (N/M)/P$	27	270	270	1	10	1	10	270
VCO bypass	$f_{OUT} = f_{IN}/(M \times P)$	30.72	0.06	0.06	8	—	64	—	—

(1) P-divider of output-switch matrix is included in the calculation.

(2) Fractional operation for $f_{VCO} \leq 250$ MHz

(3) Integer operation for $f_{VCO} > 250$ MHz

Spread-Spectrum Clocking and EMI Reduction

In addition to the basic PLL function, PLL2 supports spread-spectrum clocking (SSC). Thus, PLL 2 features two outputs, an SSC output and a non-SSC output. Both outputs can be used in parallel. The mean phase of the center-spread, SSC-modulated signal is equal to the phase of the nonmodulated input frequency. SSC is selected by output switch A (SWAPxx of bytes 9 to 12).

SSC also is bypassable (byte 25, bits [6:4]) by powering down the SSC output and setting it to the logic-low state. The non-SSC output of PLL2 is not affected by this mode and can still be used.

SSC is an effective method to reduce electromagnetic interference (EMI) noise in high-speed applications. It reduces the RF energy peak of the clock signal by modulating the frequency and spreads the energy of the signal to a broader frequency range. Because the energy of the clock signal remains constant, a varying frequency that broadens the overtones necessarily lowers their amplitudes. [Figure 19](#) shows the effect of SSC on a 54-MHz clock signal for DSP.

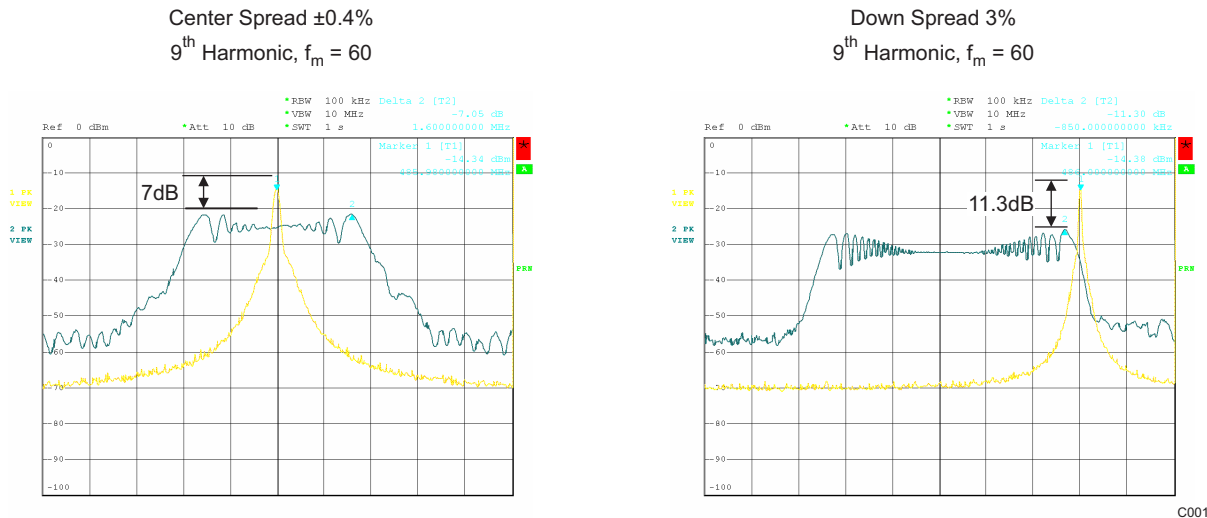

Figure 19. Spread-Spectrum Clocking With Center Spread and Down Spread

The peak amplitude of the modulated clock is 11.3 dB lower than the nonmodulated carrier frequency for down spread and radiates less electromagnetic energy.

In SSC mode, the user can select the SSC modulation amount and SSC modulation frequency. The modulation amount is the frequency deviation relative to the carrier (min/max frequency), whereas the modulation frequency determines the speed of the frequency variation. In SSC mode, the maximum VCO frequency is limited to 167 MHz.

SSC Modulation Amount

The CDCE706 supports center-spread modulation and down-spread modulation. In center spread, the clock is symmetrically shifted around the carrier frequency and can be $\pm 0.1\%$, $\pm 0.25\%$, or $\pm 0.4\%$. For down spread, the clock frequency is always lower than the carrier frequency and can be 1%, 1.5%, 2%, or 3%. The down spread is preferred if a system cannot tolerate an operating frequency higher than the nominal frequency (overclocking problem).

Example:

	Modulation Type	Minimum Frequency	Center Frequency	Maximum Frequency
A	$\pm 0.25\%$ center spread	53.865 MHz	54 MHz	54.135 MHz
B	1% down spread	53.46 MHz	—	54 MHz
C	0.5% down spread ⁽¹⁾	53.73 MHz	53.865 MHz	54 MHz

(1) A down spread of 0.5% of a 54-MHz carrier is equivalent to 59.865 MHz at a center spread of $\pm 0.25\%$.

SSC Modulation Frequency

The modulation frequency (sweep rate) can be selected between 30 kHz and 60 kHz. It is also based on the VCO frequency as shown in the *SSC Modulation Amount* as shown in the [Byte 25, Bits \[6:4\]](#) table. As shown in [Figure 20](#), the damping increases with higher modulation frequencies. It may be limited by the tracking skew of a downstream PLL. The CDCE706 uses a triangle modulation profile which is one of the common profiles for SSC.

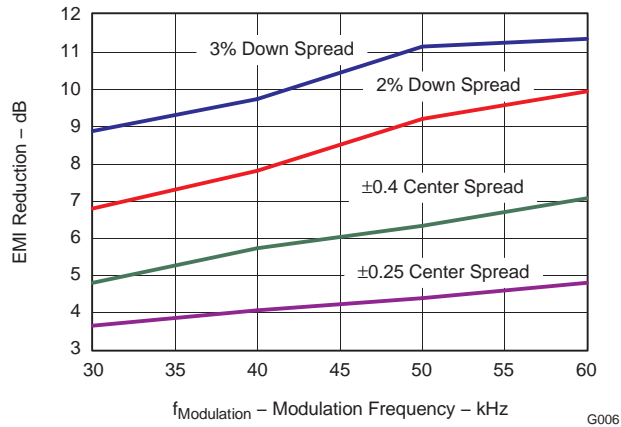

Figure 20. EMI Reduction vs $f_{\text{Modulation}}$ and f_{Amount}

Further EMI Reduction

The optimum damping is a combination of modulation amount, modulation frequency, and the harmonics which are considered. Note that higher-order harmonic frequencies result in stronger EMI reduction because of higher frequency deviation.

As seen in Figure 21 and Figure 22, a slower output slew rate and/or smaller output-signal amplitude helps to reduce EMI emission even more. Both measures reduce the RF energy of clock harmonics. The CDCE706 allows slew rate control in four steps between 0.6 ns and 3.3 ns (bytes 19–24, bits [5:4]). The output amplitude is set by the two independent output supply voltage pins, V_{CCOUT1} and V_{CCOUT2} , and can vary from 2.3 V to 3.6 V. Even a lower output supply voltage down to 1.8 V works, but the maximum frequency must be considered.

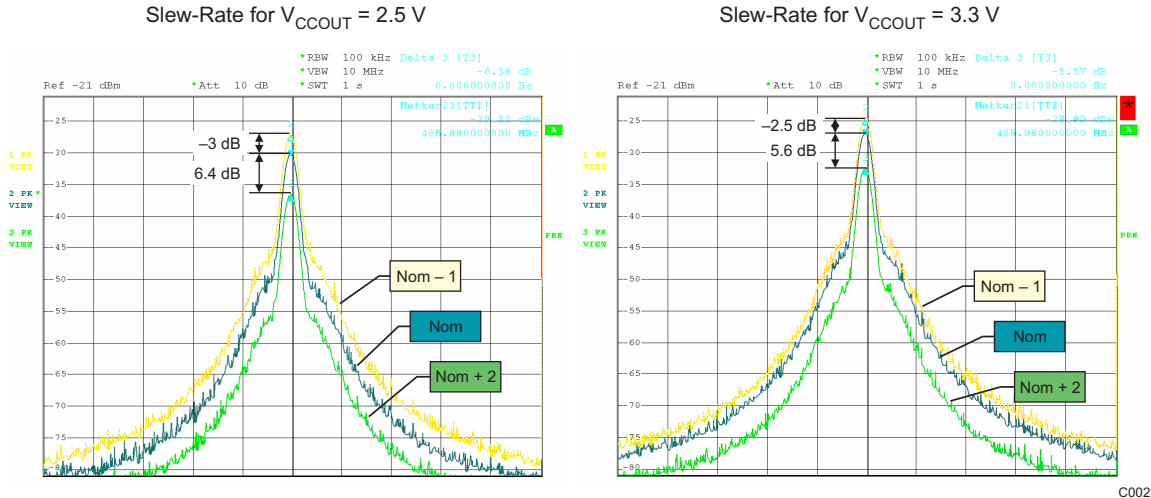

Figure 21. EMI Reduction vs Slew-Rate and V_{CCOUT}

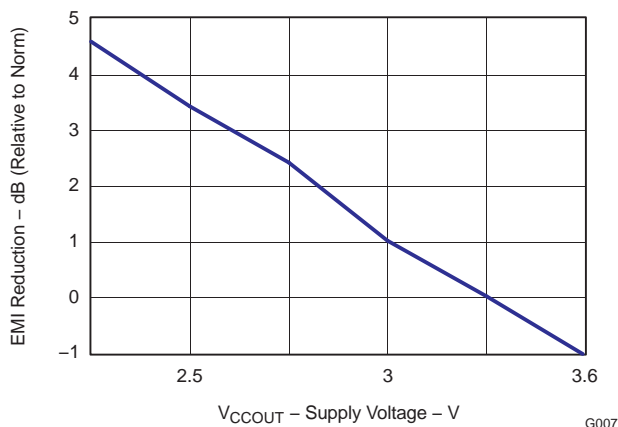

Figure 22. EMI Reduction vs V_{CCOUT}

Multifunction Control Inputs S0 and S1

The CDCE706 features two user-definable input pins which can be used as external control pins or address pins. When programmed as control pins, they can function as the clock-select pin, enable/disable pin, or device power-down pin. If both pins are used as address bits, up to four devices can be connected to the same SMBus. The function is set in byte 10, bits [3:0]. Table 4 shows the possible settings for the different output conditions, clock select, and device addresses.

Table 4. Configuration Setting of Control Inputs

Configuration Bits				External Control Pins		Device Function			
Byte 10, Bit [3:2]		Byte 10, Bit [1:0]							
S11	S10	S01	S00	S1 (Pin 2)	S0 (Pin 1)	Yx Outputs	Power Down	Pin 2	Pin 1
0	X	0	X	1	1	Active	No	Output ctrl	Output ctrl
0	0	0	X	0	1	Low/high ⁽¹⁾	No	Output ctrl	Output ctrl
0	1	0	X	0	1	High impedance	Outputs only	Output ctrl	Output ctrl
0	X	0	0	X	0	High impedance	PLL, inputs, and outputs	Output ctrl	Output ctrl and pd
0	X	0	1	0	0	S10 = 0: low/high ⁽¹⁾ S10 = 1: high impedance	PLL only	Output ctrl	PLL and div. bypass
0	X	0	1	1	0	Active	PLL only	Output ctrl	PLL and div. bypass
0	X	1	0	0	0/1 ⁽²⁾	S10 = 0: Low/High ⁽¹⁾ S10 = 1: high impedance	No	Output ctrl	CLK_SEL
0	X	1	0	1	0/1 ⁽²⁾	Active	No	Output ctrl	CLK_SEL
1	1	1	1	X	X	Active	No	A1 ⁽³⁾	A0 ⁽³⁾

(1) A noninverting output is set to low, and an inverting output is set to high.

(2) If S0 is 0, CLK_IN0 is selected; if S0 is 1, CLK_IN1 is selected.

(3) S0 and S1 are interpreted as address bits A0 and A1 of the slave receiver address byte.

As shown in Table 4, there is a specific order of the different output conditions: power-down mode overwrites high-impedance state, high-impedance state overwrites low-state, and low-state overwrites active-state.

Output Switching Matrix

The flexible architecture of the output switch matrix allows the user to switch any of the internal clock signal sources via a free-selectable post-divider to any of the six outputs.

As shown in Figure 23, the CDCE706 is based on two banks of switches and six post-dividers. Switch A comprises six five-input multiplexers which select one of the four PLL clock outputs or directly select the input clock and feed it to one of the 7-bit post-dividers (P-divider). Switch B is made up of six six-input multiplexers which take any P-divider and feed it to one of the six outputs, Yx.

Switch B was added to the output switch matrix to ensure that output frequencies derived from one P-divider are 100% phase-aligned. Also, the P-divider is built in a way that every divide factor is automatically duty-cycle corrected. Changing the divider value on the fly may cause a glitch on the output.

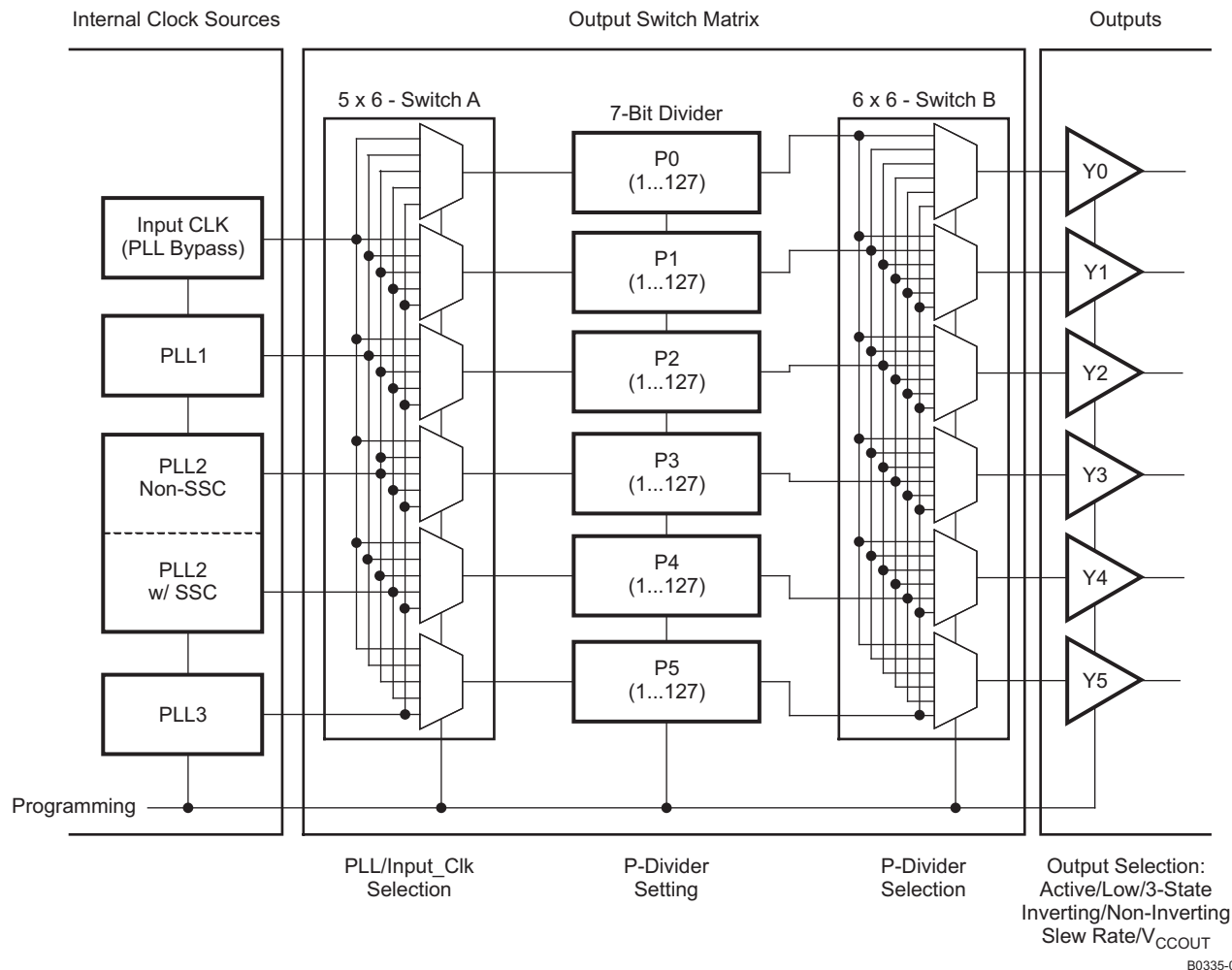

Figure 23. CDCE706 Output Switch Matrix

In addition, the outputs can be switched active, low, high-impedance state, and/or 180-degree phase-shifted. Also, the output slew rate and the output voltage are user-selectable.

LVC MOS Output Configuration

The output stage of the CDCE706 supports all common output settings, such as enable, disable, low-state, and signal inversion (180-degree phase shift). It further features slew-rate control (0.6 ns to 3.3 ns) and variable output supply voltage (2.3 V to 3.6 V).

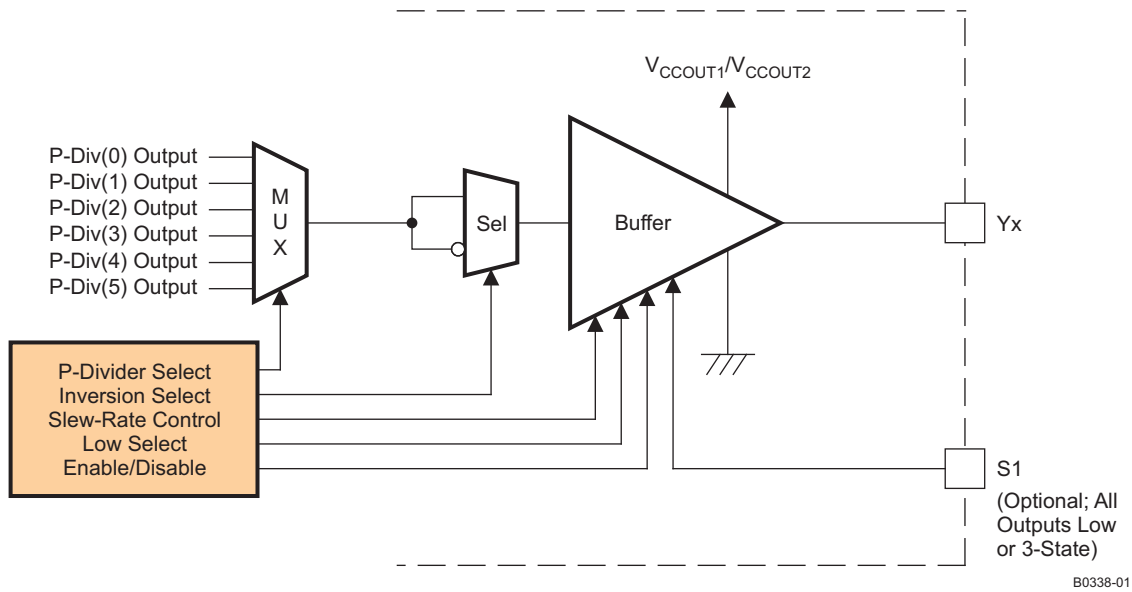

Figure 24. Block Diagram of Output Architecture

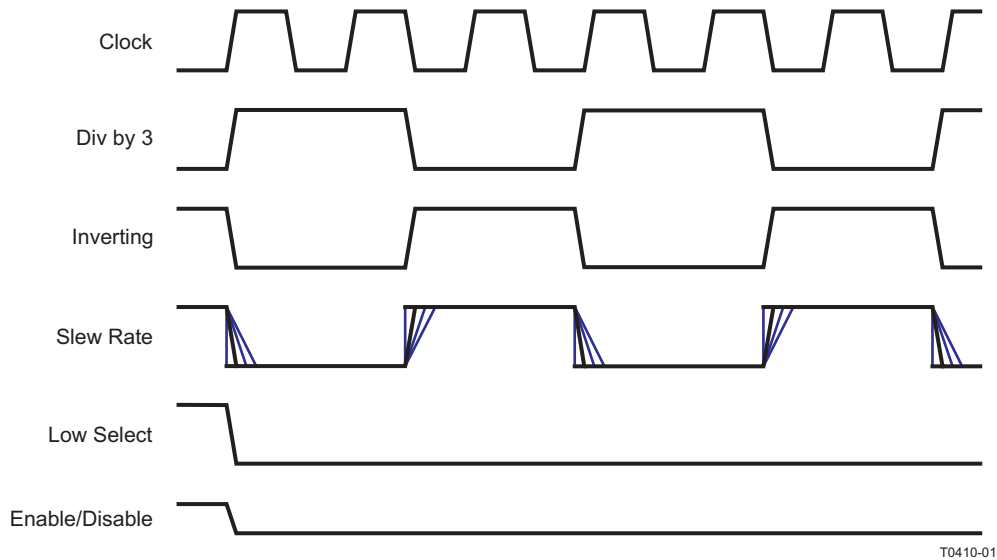

Figure 25. Example for Output Waveforms

All output settings are programmable via SMBus:

- Enable, disable, low-state via external control pins S0 and S1 → byte 10, bits[3:0]
- Enable or disable-to-low → bytes 19 to 24, bit[3]
- Inverting/noninverting → bytes 19 to 24, bit[6]
- Slew-rate control → bytes 19 to 24, bits[5:4]
- Output swing → external pins V_{CCOUT1} (pin 14) and V_{CCOUT2} (pin 18)

Performance Data: Output Skew, Jitter, Cross-Coupling, Noise Rejection (Spur Suppression), and Phase Noise

Output Skew

Skew is an important parameter for clock distribution circuits. It is defined as the time difference between outputs that are driven by the same input clock. [Table 5](#) shows the output skew ($t_{sk(o)}$) of the CDCE706 for high-to-low and low-to-high transitions over the entire range of supply voltages, operating temperature and output voltage swing.

Table 5. Output Skew

PARAMETER	CONDITION	TYP	MAX	UNIT
$t_{sk(o)}$ Output skew	$V_{CCOUT} = 2.5\text{ V}$	130	250	ps
	$V_{CCOUT} = 3.3\text{ V}$	130	200	ps

Jitter Performance

Jitter is a major parameter for PLL-based clock driver circuits. This becomes important as speed increases and timing budget decreases. The PLL and internal circuits of CDCE706 are designed for lowest jitter. The peak-to-peak period jitter is only 60 ps (typical). [Table 6](#) gives the peak-to-peak and rms deviation of cycle-to-cycle jitter, period jitter and phase jitter as taken during characterization.

Table 6. Jitter Performance of CDCE706

PARAMETER	CONDITION	TYP ⁽¹⁾		MAX ⁽¹⁾		UNIT
		Peak-Peak	rms (One Sigma)	Peak-Peak	rms (One Sigma)	
$t_{jit(cc)}$ Cycle-to-cycle jitter	$f_{out} = 50\text{ MHz}$	55	–	75	–	ps
	$f_{out} = 133\text{ MHz}$	50	–	85	–	
	$f_{out} = 245.76\text{ MHz}$	45	–	60	–	
$t_{jit(per)}$ Period jitter	$f_{out} = 50\text{ MHz}$	60	4	76	7	ps
	$f_{out} = 133\text{ MHz}$	55	5	84	11	
	$f_{out} = 245.76\text{ MHz}$	55	5	72	8	
$t_{jit(phase)}$ Phase jitter	$f_{out} = 50\text{ MHz}$	730	90	840	115	ps
	$f_{out} = 133\text{ MHz}$	930	130	1310	175	
	$f_{out} = 245.76\text{ MHz}$	720	90	930	125	

(1) All typical and maximum values are at $V_{CC} = 3.3\text{ V}$, temperature = 25°C, $V_{CCOUT} = 3.3\text{ V}$; one output is switching, data taken over several 10,000 cycles.

[Figure 26](#), [Figure 27](#), and [Figure 28](#) show the relationship between cycle-to-cycle jitter, period jitter, and phase jitter over 10,000 samples. The jitter varies with a smaller or wider sample window. The cycle-to-cycle jitter and period jitter show the measured value, whereas the phase jitter is the accumulated period jitter.

Cycle-to-Cycle jitter ($t_{jit(cc)}$) is the variation in cycle time of a clock signal between adjacent cycles, over a random sample of adjacent cycle pairs. Cycle-to-cycle jitter is never greater than the period jitter. It is also known as adjacent-cycle jitter.

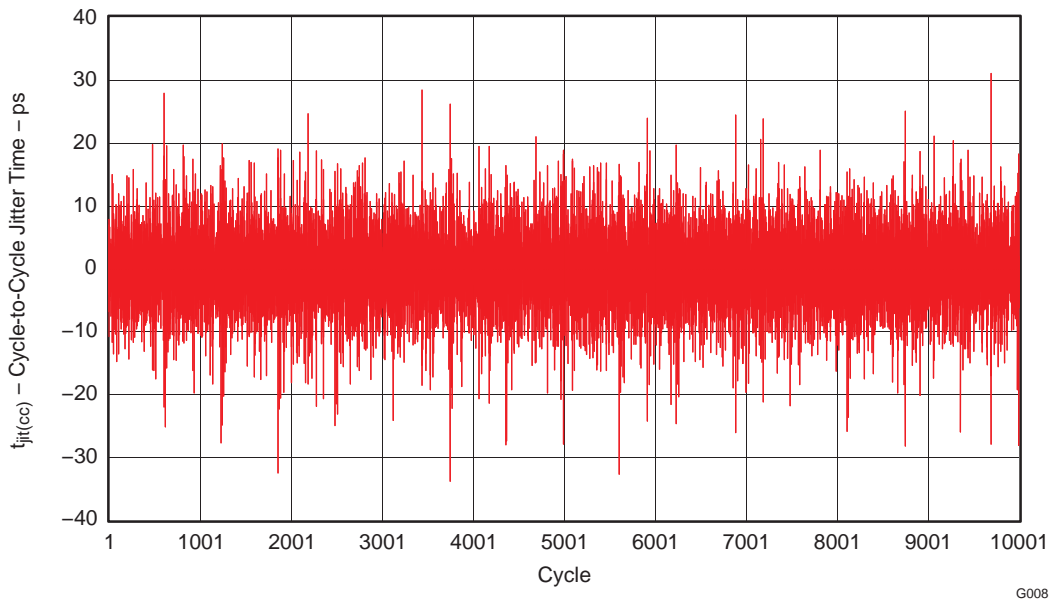

Figure 26. Snapshot of Cycle-to-Cycle Jitter

Period jitter ($t_{\text{jitter(per)}}$) is the deviation in cycle time of a clock signal with respect to the ideal period ($1/f_0$) over a random sample of cycles. In reference to a PLL, period jitter is the worst-case period deviation from the ideal that would ever occur on the PLL outputs. This is also referred to as short-term jitter.

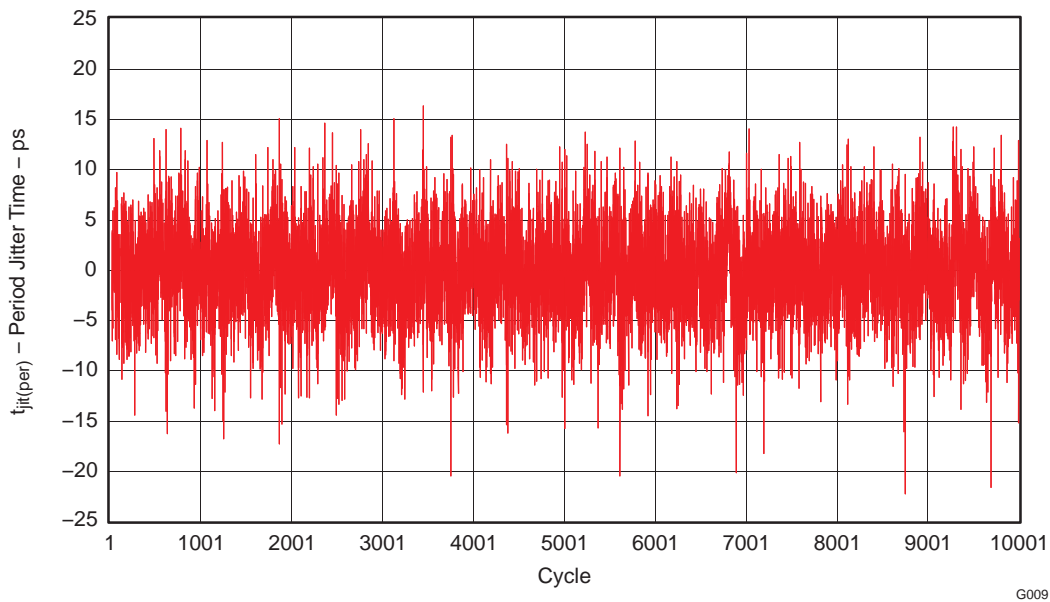

Figure 27. Snapshot of Period Jitter

Phase jitter ($t_{\text{jitter(phase)}}$) is the long-term variation of the clock signal. It is the cumulative deviation in $t(\Theta)$ for a controlled edge with respect to a $t(\Theta)$ mean in a random sample of cycles. Phase jitter, time-interval error (TIE), and wander are used in literature to describe long-term variation in frequency. As of ITU-T: G.810, wander is defined as phase variation at rates less than 10 Hz, whereas jitter is defined as phase variation greater than 10 Hz. The measurement interval must be long enough to gain a meaningful result. Wander can be caused by temperature drift, aging, supply-voltage drift, etc.

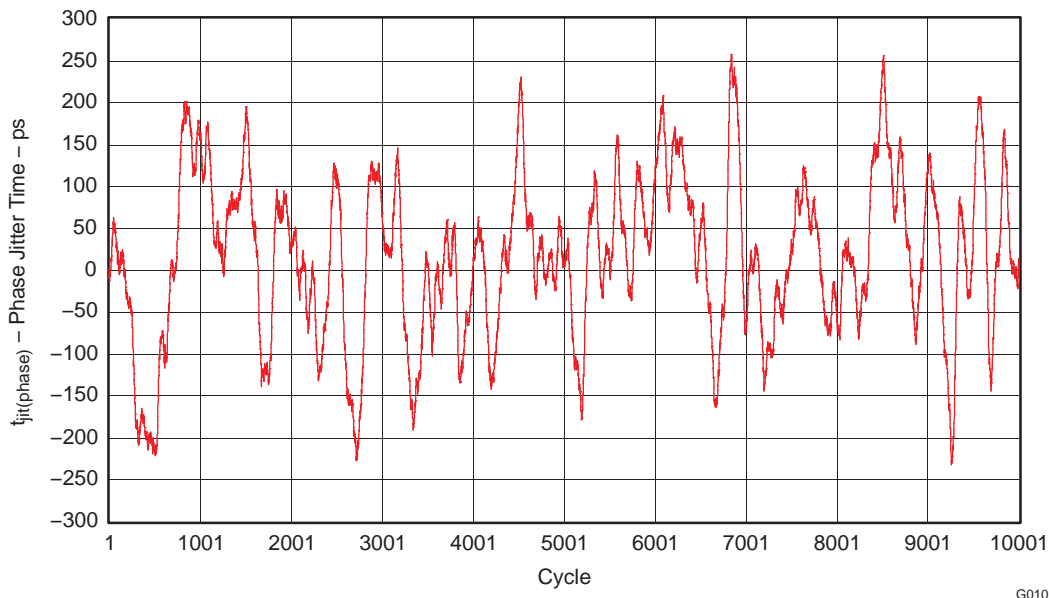

Figure 28. Snapshot of Phase Jitter

Jitter depends on the VCO frequency (f_{VCO}) of the PLL. A higher f_{VCO} results in better jitter performance compared to a lower f_{VCO} . The VCO frequency can be defined via the M- and N-dividers of the PLL.

As the CDCE706 supports a wide frequency range, the device offers VCO frequency-selection bits, bits [7:5] of byte 6. These bits define the jitter-optimized frequency range of each PLL. The user can select between the normal-speed mode (80 MHz to 200 MHz) and the high-speed mode (180 MHz to 300 MHz). Figure 29 shows the jitter performance over f_{VCO} for the two frequency ranges.

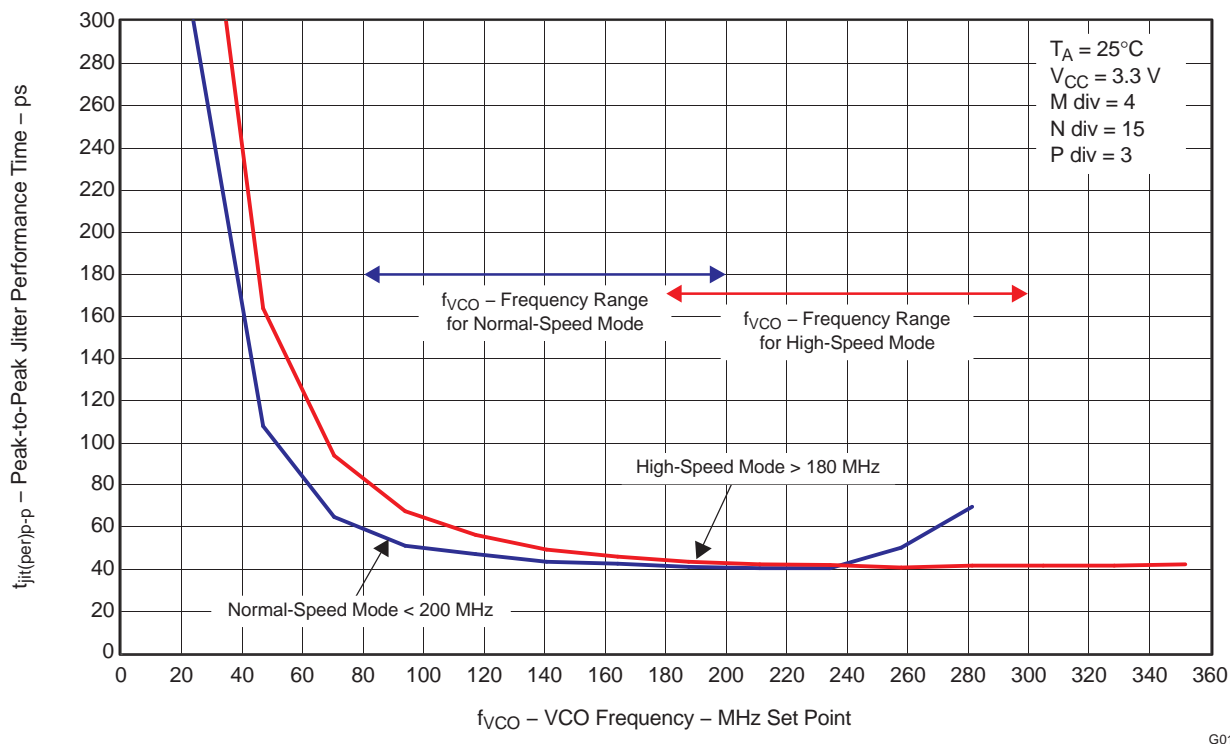

Figure 29. Period Jitter vs f_{VCO} for Normal-Speed Mode and High-Speed Mode

The TI Pro Clock software automatically calculates the PLL parameter for jitter-optimized performance.

Cross-Coupling, Spur Suppression, and Noise Rejection

Cross-coupling in ICs occurs through interactions between several parts of the chip such as between output stages, metal lines, bond wires, substrate, etc. The coupling can be capacitive, inductive, and resistive (ohmic), induced by output switching, leakage current, ground bouncing, power supply transients, etc.

The CDCE706 is designed using RFSiGe process technology. This process gives excellent performance in linearity, low power consumption, best-in-class noise performance, and very good isolation characteristics between the on-chip components.

The good isolation is a major benefit of the RFSiGe process because it minimizes the coupling effect. Even if all three PLLs are active and all outputs are on, the noise suppression is well above 50 dB. Figure 30 and Figure 31 show an example of noise coupling, spur-suppression, and power-supply noise rejection of the CDCE706. The measurement conditions are shown in Figure 30 and Figure 31.

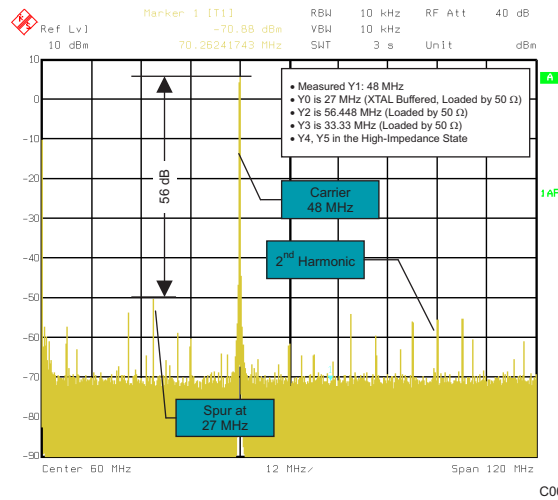

Figure 30. Noise Coupling and Spur Suppression

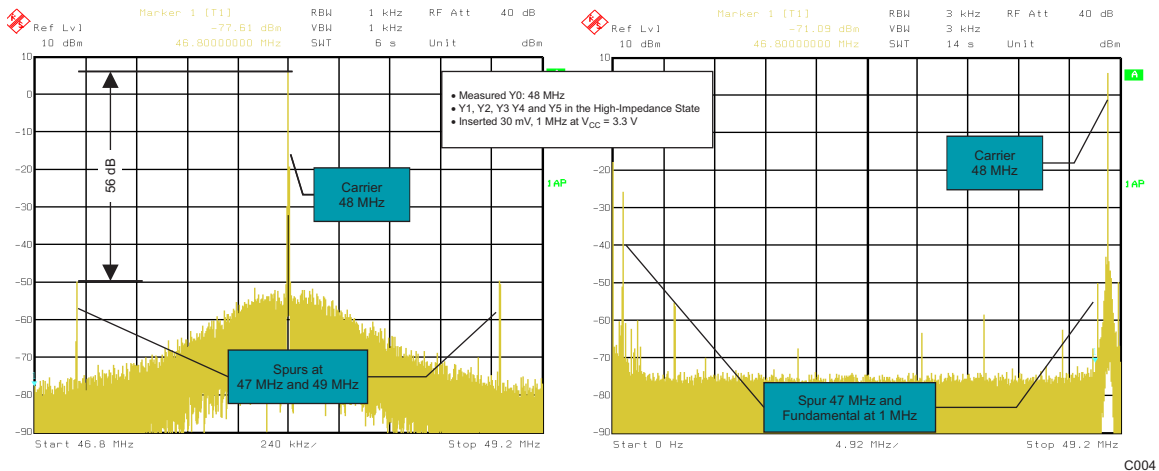

Figure 31. Power-Supply Noise Rejection

Phase Noise Characteristic

In high-speed communication systems, the phase-noise characteristic of the PLL frequency synthesizer is of high interest. Phase noise describes the stability of the clock signal in the frequency domain, similar to the jitter specification in the time domain.

Phase noise is a result of random and discrete noise causing a broad slope and spurious peaks. The discrete spurious components could be caused by known clock frequencies in the signal source, power line interference, and mixer products. The broadening caused by random noise fluctuation is due to phase noise. It can be the result of thermal noise, shot noise, and/or flicker noise in active and passive devices.

An important factor for the PLL synthesizer is the loop bandwidth (–3-dB cutoff frequency)—large loop bandwidth (LBW) results in fast transient response but less reference spur attenuation. The LBW of the CDCE706 is about 100 kHz to 250 kHz, depending on the selected PLL parameter.

For the CDCE706, two phase-noise characteristics are of interest, the phase noise of the crystal-input stage and the phase noise of the internal PLL (VCO). Figure 32 shows the respective phase noise characteristic.

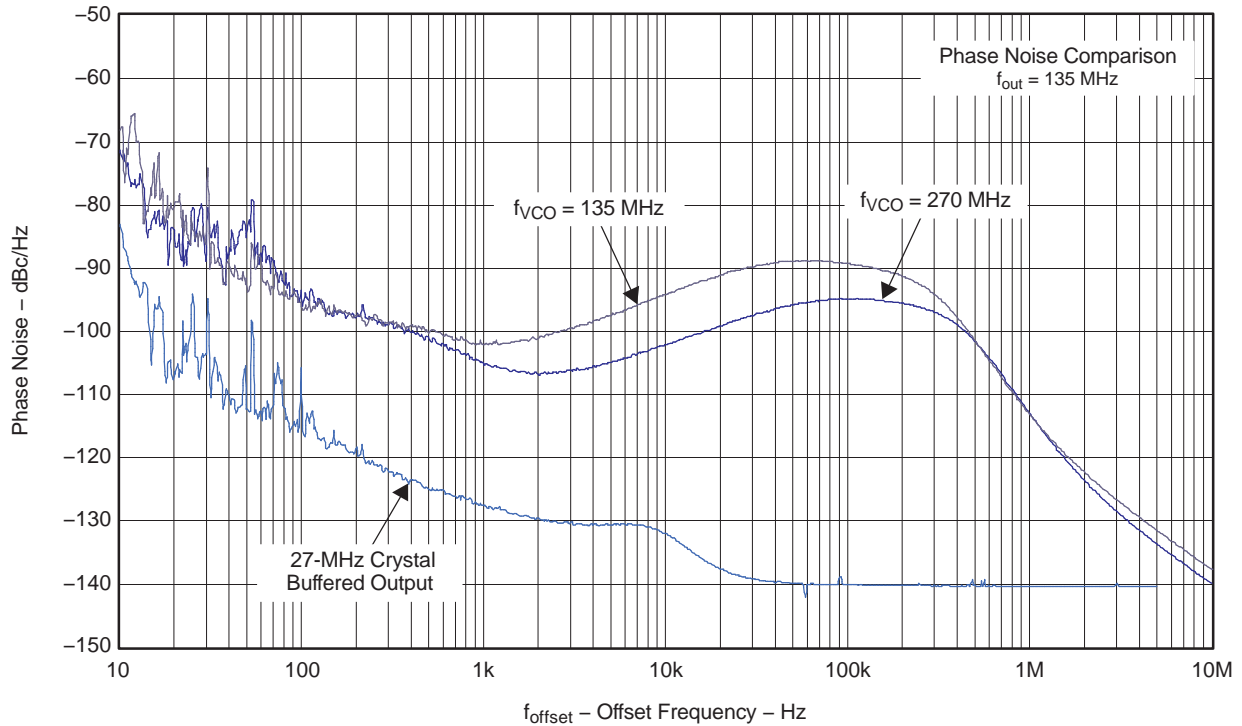

Figure 32. Phase Noise Characteristic

PLL-Lock Time

Some applications use frequency switching, e.g., changing frequency in a TV application (switching between channels) or changing the PCI-X frequency in computers. The time spent by the PLL in achieving the new frequency is of main interest. The lock time is the time it takes to jump from one specified frequency to another specified frequency within a given frequency tolerance (see Figure 33). It should be low, because a long lock time impacts the data rate of the system.

The PLL-lock time depends on the device configuration and can be changed by the VCO frequency, i.e., by changing the M/N divider values. Table 7 gives the typical lock times of the CDCE706 and Figure 33 shows a snapshot of a frequency switch.

Table 7. CDCE706 PLL Lock-Times

Description	Lock Time	Unit
Frequency change via reprogramming of N/M counter	100	μs
Frequency change via CLK_SEL pin (switching between CLK_IN0 and CLK_IN1)	100	μs
Power-up lock time with system clock	50	μs
Power-up lock time with 27-MHz crystal at CLK_IN0 and CLK_IN1	300 ⁽¹⁾	μs

(1) Is the result of crystal lock time (200 μs) and PLL lock time (100 μs).

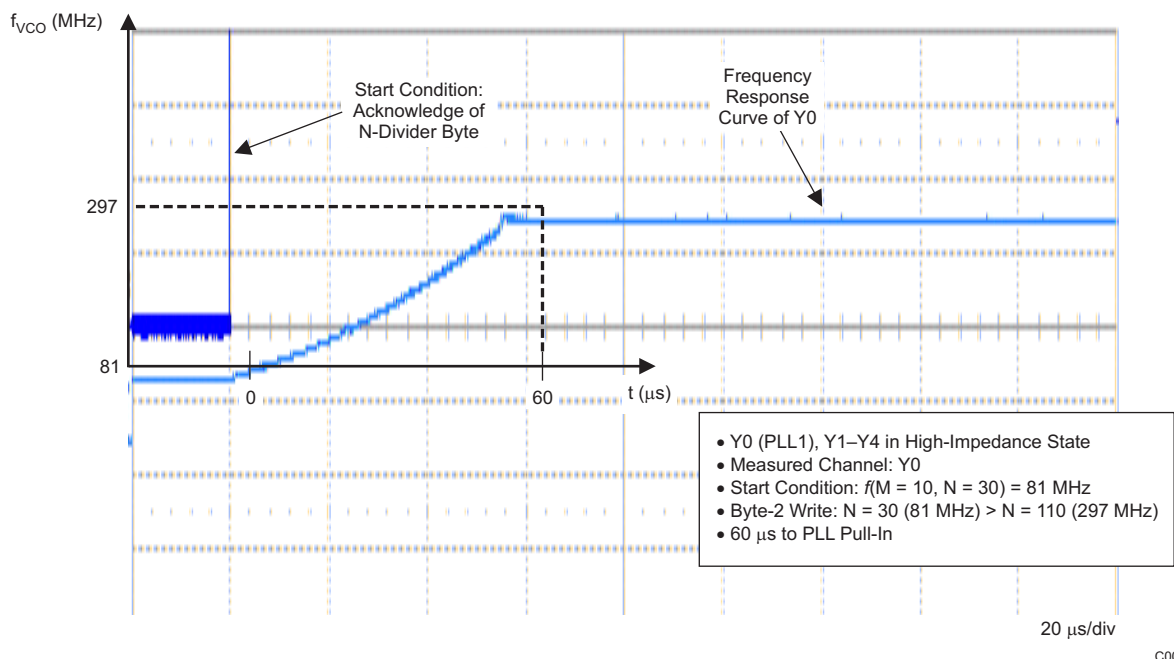

Figure 33. Snapshot of the PLL Lock-Time

Power-Supply Sequencing

The CDCE706 includes three power-supply pins, V_{CC} , V_{CCOUT1} , and V_{CCOUT2} . There are no power-supply sequencing requirements, as the three power nodes are separated from each other. So, power can be supplied in any order to the three nodes.

Also, the part has power-up circuitry which switches the device on if V_{CC} exceeds 2.1 V (typ) and switches the device off at $V_{CC} < 1.7$ V (typ). In power-down mode, all outputs and clock inputs are switched off.

Device Behavior During Supply-Voltage Drops

The CDCE706 has a power-up circuit, which activates the device functionality at V_{PUC_ON} (typical 2.1 V). At the same time, the EEPROM information is loaded into the register. This mechanism ensures that there is a predefined default after power up and no need to reprogram the CDCE706 in the application.

In the event of a supply-voltage drop, the power-up circuit ensures that there is always a defined setup within the register. [Figure 34](#) shows possible voltage drops with different amplitudes.

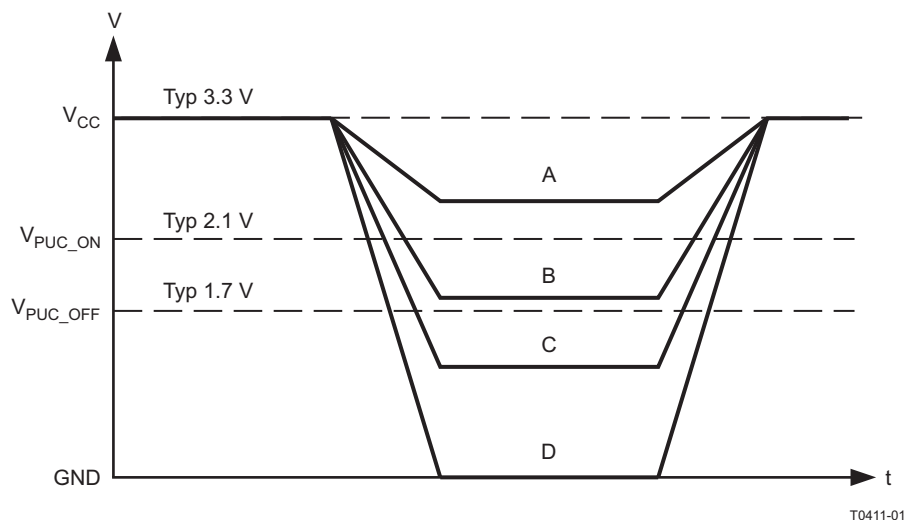

Figure 34. Different Voltage Drops on V_{CC} During Operation

The CDCE706 power-up circuit has built-in hysteresis. If the voltage stays above V_{PUC_OFF} , which is typically at 1.7 V, the register content stays unchanged. If the voltage drops below V_{PUC_OFF} , the internal register is reloaded by the EEPROM after V_{PUC_ON} is crossed again. V_{PUC_ON} is typically 2.1 V. Table 8 shows the content of the EEPROM and the register after the voltage-drop scenarios shown in Figure 34.

Table 8. EEPROM and Register Content After V_{CC} Drop

Power Drop	EEPROM Content	Register Content
A	Unchanged	Unchanged
B	Unchanged	Unchanged
C	Unchanged	Reloaded from EEPROM
D	Unchanged	Reloaded from EEPROM

EVM and Programming Software

The CDCE706 EVM is a development kit consisting of a performance evaluation module, the TI Pro Clock software, and the User's Guide. Contact a Texas Instruments sales or marketing representative for more information.

PACKAGING INFORMATION

Orderable Device	Status (1)	Package Type	Package Drawing	Pins	Package Qty	Eco Plan (2)	Lead/Ball Finish (6)	MSL Peak Temp (3)	Op Temp (°C)	Device Marking (4/5)	Samples
CDCE706PW	ACTIVE	TSSOP	PW	20	70	Green (RoHS & no Sb/Br)	CU NIPDAU	Level-1-260C-UNLIM	-40 to 85	CDCE706	Samples
CDCE706PWG4	ACTIVE	TSSOP	PW	20	70	Green (RoHS & no Sb/Br)	CU NIPDAU	Level-1-260C-UNLIM	-40 to 85	CDCE706	Samples
CDCE706PWR	ACTIVE	TSSOP	PW	20	2000	Green (RoHS & no Sb/Br)	CU NIPDAU	Level-1-260C-UNLIM	-40 to 85	CDCE706	Samples
CDCE706PWRG4	ACTIVE	TSSOP	PW	20	2000	Green (RoHS & no Sb/Br)	CU NIPDAU	Level-1-260C-UNLIM	-40 to 85	CDCE706	Samples

(1) The marketing status values are defined as follows:

ACTIVE: Product device recommended for new designs.

LIFEBUY: TI has announced that the device will be discontinued, and a lifetime-buy period is in effect.

NRND: Not recommended for new designs. Device is in production to support existing customers, but TI does not recommend using this part in a new design.

PREVIEW: Device has been announced but is not in production. Samples may or may not be available.

OBSOLETE: TI has discontinued the production of the device.

(2) Eco Plan - The planned eco-friendly classification: Pb-Free (RoHS), Pb-Free (RoHS Exempt), or Green (RoHS & no Sb/Br) - please check <http://www.ti.com/productcontent> for the latest availability information and additional product content details.

TBD: The Pb-Free/Green conversion plan has not been defined.

Pb-Free (RoHS): TI's terms "Lead-Free" or "Pb-Free" mean semiconductor products that are compatible with the current RoHS requirements for all 6 substances, including the requirement that lead not exceed 0.1% by weight in homogeneous materials. Where designed to be soldered at high temperatures, TI Pb-Free products are suitable for use in specified lead-free processes.

Pb-Free (RoHS Exempt): This component has a RoHS exemption for either 1) lead-based flip-chip solder bumps used between the die and package, or 2) lead-based die adhesive used between the die and leadframe. The component is otherwise considered Pb-Free (RoHS compatible) as defined above.

Green (RoHS & no Sb/Br): TI defines "Green" to mean Pb-Free (RoHS compatible), and free of Bromine (Br) and Antimony (Sb) based flame retardants (Br or Sb do not exceed 0.1% by weight in homogeneous material)

(3) MSL, Peak Temp. - The Moisture Sensitivity Level rating according to the JEDEC industry standard classifications, and peak solder temperature.

(4) There may be additional marking, which relates to the logo, the lot trace code information, or the environmental category on the device.

(5) Multiple Device Markings will be inside parentheses. Only one Device Marking contained in parentheses and separated by a "~" will appear on a device. If a line is indented then it is a continuation of the previous line and the two combined represent the entire Device Marking for that device.

(6) Lead/Ball Finish - Orderable Devices may have multiple material finish options. Finish options are separated by a vertical ruled line. Lead/Ball Finish values may wrap to two lines if the finish value exceeds the maximum column width.

Important Information and Disclaimer: The information provided on this page represents TI's knowledge and belief as of the date that it is provided. TI bases its knowledge and belief on information provided by third parties, and makes no representation or warranty as to the accuracy of such information. Efforts are underway to better integrate information from third parties. TI has taken and continues to take reasonable steps to provide representative and accurate information but may not have conducted destructive testing or chemical analysis on incoming materials and chemicals. TI and TI suppliers consider certain information to be proprietary, and thus CAS numbers and other limited information may not be available for release.

In no event shall TI's liability arising out of such information exceed the total purchase price of the TI part(s) at issue in this document sold by TI to Customer on an annual basis.

TAPE AND REEL INFORMATION



QUADRANT ASSIGNMENTS FOR PIN 1 ORIENTATION IN TAPE



*All dimensions are nominal

Device	Package Type	Package Drawing	Pins	SPQ	Reel Diameter (mm)	Reel Width W1 (mm)	A0 (mm)	B0 (mm)	K0 (mm)	P1 (mm)	W (mm)	Pin1 Quadrant
CDCE706PWR	TSSOP	PW	20	2000	330.0	16.4	6.95	7.1	1.6	8.0	16.0	Q1

TAPE AND REEL BOX DIMENSIONS



*All dimensions are nominal

Device	Package Type	Package Drawing	Pins	SPQ	Length (mm)	Width (mm)	Height (mm)
CDCE706PWR	TSSOP	PW	20	2000	367.0	367.0	38.0

PW (R-PDSO-G20)

PLASTIC SMALL OUTLINE

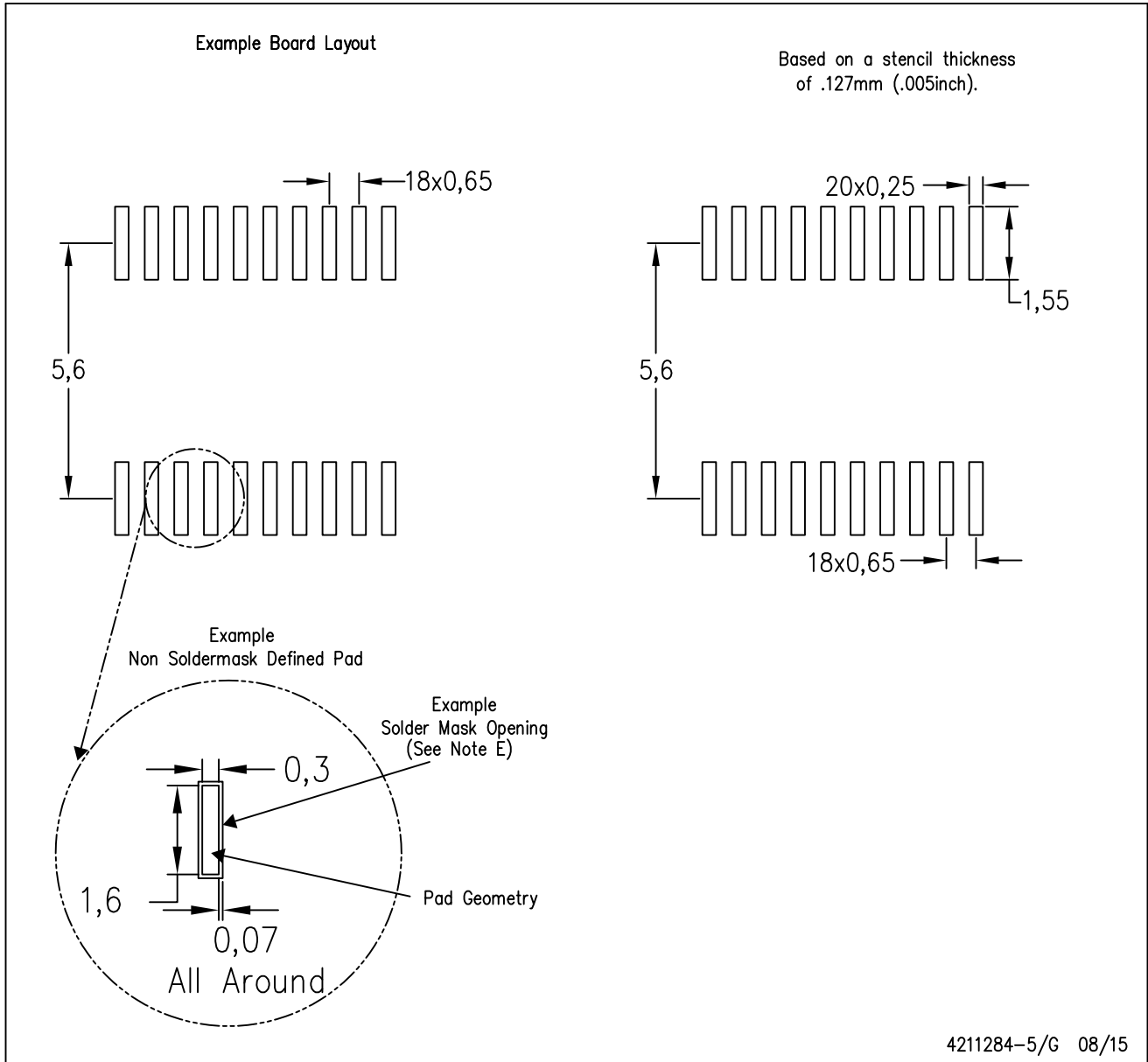

- NOTES:
- A. All linear dimensions are in millimeters.
 - B. This drawing is subject to change without notice.
 - C. Publication IPC-7351 is recommended for alternate design.
 - D. Laser cutting apertures with trapezoidal walls and also rounding corners will offer better paste release. Customers should contact their board assembly site for stencil design recommendations. Refer to IPC-7525 for other stencil recommendations.
 - E. Customers should contact their board fabrication site for solder mask tolerances between and around signal pads.

IMPORTANT NOTICE

Texas Instruments Incorporated (TI) reserves the right to make corrections, enhancements, improvements and other changes to its semiconductor products and services per JESD46, latest issue, and to discontinue any product or service per JESD48, latest issue. Buyers should obtain the latest relevant information before placing orders and should verify that such information is current and complete.

TI's published terms of sale for semiconductor products (<http://www.ti.com/sc/docs/stdterms.htm>) apply to the sale of packaged integrated circuit products that TI has qualified and released to market. Additional terms may apply to the use or sale of other types of TI products and services.

Reproduction of significant portions of TI information in TI data sheets is permissible only if reproduction is without alteration and is accompanied by all associated warranties, conditions, limitations, and notices. TI is not responsible or liable for such reproduced documentation. Information of third parties may be subject to additional restrictions. Resale of TI products or services with statements different from or beyond the parameters stated by TI for that product or service voids all express and any implied warranties for the associated TI product or service and is an unfair and deceptive business practice. TI is not responsible or liable for any such statements.

Buyers and others who are developing systems that incorporate TI products (collectively, "Designers") understand and agree that Designers remain responsible for using their independent analysis, evaluation and judgment in designing their applications and that Designers have full and exclusive responsibility to assure the safety of Designers' applications and compliance of their applications (and of all TI products used in or for Designers' applications) with all applicable regulations, laws and other applicable requirements. Designer represents that, with respect to their applications, Designer has all the necessary expertise to create and implement safeguards that (1) anticipate dangerous consequences of failures, (2) monitor failures and their consequences, and (3) lessen the likelihood of failures that might cause harm and take appropriate actions. Designer agrees that prior to using or distributing any applications that include TI products, Designer will thoroughly test such applications and the functionality of such TI products as used in such applications.

TI's provision of technical, application or other design advice, quality characterization, reliability data or other services or information, including, but not limited to, reference designs and materials relating to evaluation modules, (collectively, "TI Resources") are intended to assist designers who are developing applications that incorporate TI products; by downloading, accessing or using TI Resources in any way, Designer (individually or, if Designer is acting on behalf of a company, Designer's company) agrees to use any particular TI Resource solely for this purpose and subject to the terms of this Notice.

TI's provision of TI Resources does not expand or otherwise alter TI's applicable published warranties or warranty disclaimers for TI products, and no additional obligations or liabilities arise from TI providing such TI Resources. TI reserves the right to make corrections, enhancements, improvements and other changes to its TI Resources. TI has not conducted any testing other than that specifically described in the published documentation for a particular TI Resource.

Designer is authorized to use, copy and modify any individual TI Resource only in connection with the development of applications that include the TI product(s) identified in such TI Resource. NO OTHER LICENSE, EXPRESS OR IMPLIED, BY ESTOPPEL OR OTHERWISE TO ANY OTHER TI INTELLECTUAL PROPERTY RIGHT, AND NO LICENSE TO ANY TECHNOLOGY OR INTELLECTUAL PROPERTY RIGHT OF TI OR ANY THIRD PARTY IS GRANTED HEREIN, including but not limited to any patent right, copyright, mask work right, or other intellectual property right relating to any combination, machine, or process in which TI products or services are used. Information regarding or referencing third-party products or services does not constitute a license to use such products or services, or a warranty or endorsement thereof. Use of TI Resources may require a license from a third party under the patents or other intellectual property of the third party, or a license from TI under the patents or other intellectual property of TI.

TI RESOURCES ARE PROVIDED "AS IS" AND WITH ALL FAULTS. TI DISCLAIMS ALL OTHER WARRANTIES OR REPRESENTATIONS, EXPRESS OR IMPLIED, REGARDING RESOURCES OR USE THEREOF, INCLUDING BUT NOT LIMITED TO ACCURACY OR COMPLETENESS, TITLE, ANY EPIDEMIC FAILURE WARRANTY AND ANY IMPLIED WARRANTIES OF MERCHANTABILITY, FITNESS FOR A PARTICULAR PURPOSE, AND NON-INFRINGEMENT OF ANY THIRD PARTY INTELLECTUAL PROPERTY RIGHTS. TI SHALL NOT BE LIABLE FOR AND SHALL NOT DEFEND OR INDEMNIFY DESIGNER AGAINST ANY CLAIM, INCLUDING BUT NOT LIMITED TO ANY INFRINGEMENT CLAIM THAT RELATES TO OR IS BASED ON ANY COMBINATION OF PRODUCTS EVEN IF DESCRIBED IN TI RESOURCES OR OTHERWISE. IN NO EVENT SHALL TI BE LIABLE FOR ANY ACTUAL, DIRECT, SPECIAL, COLLATERAL, INDIRECT, PUNITIVE, INCIDENTAL, CONSEQUENTIAL OR EXEMPLARY DAMAGES IN CONNECTION WITH OR ARISING OUT OF TI RESOURCES OR USE THEREOF, AND REGARDLESS OF WHETHER TI HAS BEEN ADVISED OF THE POSSIBILITY OF SUCH DAMAGES.

Unless TI has explicitly designated an individual product as meeting the requirements of a particular industry standard (e.g., ISO/TS 16949 and ISO 26262), TI is not responsible for any failure to meet such industry standard requirements.

Where TI specifically promotes products as facilitating functional safety or as compliant with industry functional safety standards, such products are intended to help enable customers to design and create their own applications that meet applicable functional safety standards and requirements. Using products in an application does not by itself establish any safety features in the application. Designers must ensure compliance with safety-related requirements and standards applicable to their applications. Designer may not use any TI products in life-critical medical equipment unless authorized officers of the parties have executed a special contract specifically governing such use. Life-critical medical equipment is medical equipment where failure of such equipment would cause serious bodily injury or death (e.g., life support, pacemakers, defibrillators, heart pumps, neurostimulators, and implantables). Such equipment includes, without limitation, all medical devices identified by the U.S. Food and Drug Administration as Class III devices and equivalent classifications outside the U.S.

TI may expressly designate certain products as completing a particular qualification (e.g., Q100, Military Grade, or Enhanced Product). Designers agree that it has the necessary expertise to select the product with the appropriate qualification designation for their applications and that proper product selection is at Designers' own risk. Designers are solely responsible for compliance with all legal and regulatory requirements in connection with such selection.

Designer will fully indemnify TI and its representatives against any damages, costs, losses, and/or liabilities arising out of Designer's non-compliance with the terms and provisions of this Notice.

Looking for pricing, stock, or lifecycle information?

Click below to explore more details on WIN SOURCE:

 [View CDCE706PWR](#) on WIN SOURCE

 [Texas Instruments](#) Information

Optimize Your Supply Chain with WIN SOURCE Solutions

-  Global Sourcing Solution
-  Obsolete Management
-  Cost Control Management
-  Shortage Management
-  Alternative Solution
-  Excess Inventory Management