



**THE DATASHEET OF
CDCE62005RGZT**



CDCE62005 3:5 Clock Generator, Jitter Cleaner with Integrated Dual VCOs

1 Features

- **Superior Performance:**
 - Low Noise Clock Generator: 550 fs rms typical (10 kHz to 20 MHz Integration Bandwidth), $F_C = 100$ MHz
 - Low Noise Jitter Cleaner: 2.6 ps rms typical (10 kHz to 20 MHz Integration Bandwidth), $F_C = 100$ MHz
- **Flexible Frequency Planning:**
 - 5 Fully Configurable Outputs: LVPECL, LVDS, LVCMOS and Special High Swing Output Modes
 - Unique Dual-VCO Architecture Supports a Wide Tuning Range: 1.750 GHz to 2.356 GHz
 - Output Frequency Ranges from 4.25 MHz to 1.175 GHz in Synthesizer Mode
 - Output Frequency up to 1.5 GHz in Fan-Out Mode
 - Independent Coarse Skew Control on all Outputs
- **High Flexibility:**
 - Integrated EEPROM Determines Device Configuration at Power-up
 - Smart Input Multiplexer Automatically Switches Between One of Three Reference Inputs
- 7-mm x 7-mm 48-Pin VQFN Package (RGZ)
- -40°C to $+85^{\circ}\text{C}$ Temperature Range

2 Applications

- Wireless Infrastructure
- Switches and Routers
- Medical Electronics
- Military and Aerospace
- Industrial

3 Description

The CDCE62005 is a high performance clock generator and distributor featuring low output jitter, a high degree of configurability via a SPI interface, and programmable start up modes determined by on-chip EEPROM. Specifically tailored for clocking data converters and high-speed digital signals, the CDCE62005 achieves jitter performance well under 1 ps RMS (10 kHz to 20 MHz integration bandwidth).

The CDCE62005 incorporates a synthesizer block with partially integrated loop filter, a clock distribution block including programmable output formats, and an input block featuring an innovative smart multiplexer. The clock distribution block includes five individually programmable outputs that can be configured to provide different combinations of output formats (LVPECL, LVDS, LVCMOS). Each output can also be programmed to a unique output frequency (up to 1.5 GHz) and skew relationship via a programmable delay block (note that frequency range depends on operational mode and output format selected). If all outputs are configured in single-ended mode (for example, LVCMOS), the CDCE62005 supports up to ten outputs. Each output can select one of four clock sources to condition and distribute including any of the three clock inputs or the output of the frequency synthesizer. The input block includes two universal differential inputs which support frequencies in the range of 40 kHz to 500 MHz and an auxiliary input that can be configured to connect to an external crystal via an on chip oscillator block.

The smart input multiplexer has two modes of operation, manual and automatic. In manual mode, the user selects the synthesizer reference via the SPI interface. In automatic mode, the input multiplexer will automatically select between the highest priority input clock available.

Device Information⁽¹⁾

PART NUMBER	PACKAGE	BODY SIZE (NOM)
CDCE62005	VQFN (48)	7.00 mm x 7.00 mm

(1) For all available packages, see the orderable addendum at the end of the datasheet.

Application Example

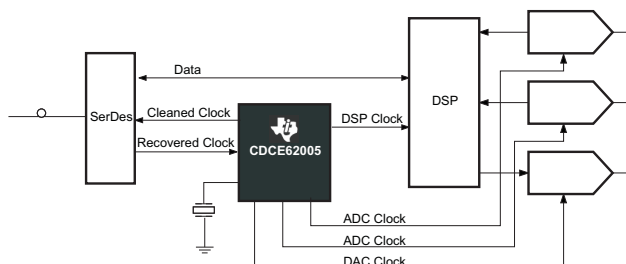

Table of Contents

1 Features	1	8.3 Feature Description.....	20
2 Applications	1	8.4 Device Functional Modes.....	52
3 Description	1	8.5 Programming.....	55
4 Revision History	2	8.6 Register Maps	61
5 Pin Configuration and Functions	4	9 Application and Implementation	70
6 Specifications	6	9.1 Application Information.....	70
6.1 Absolute Maximum Ratings	6	9.2 Typical Application	70
6.2 ESD Ratings.....	6	10 Power Supply Recommendations	74
6.3 Thermal Information	6	11 Layout	76
6.4 Electrical Characteristics.....	7	11.1 Layout Guidelines	76
6.5 Timing Requirements	11	11.2 Layout Example	76
6.6 SPI Bus Timing Characteristics	11	12 Device and Documentation Support	77
6.7 Typical Characteristics	12	12.1 Trademarks	77
7 Parameter Measurement Information	13	12.2 Documentation Support	77
8 Detailed Description	14	12.3 Electrostatic Discharge Caution.....	77
8.1 Overview	14	12.4 Glossary	77
8.2 Functional Block Diagrams	14	13 Mechanical, Packaging, and Orderable Information	77

4 Revision History

Changes from Revision F (January 2015) to Revision G Page

- Removed minimum and maximum values and added typical value to on-chip load capacitance in *Electrical Characteristics*

7

Changes from Revision E (July 2014) to Revision F Page

- Added Low Noise Clock Generator: 550 fs rms typical (10 kHz to 20 MHz Integration Bandwidth), $F_C = 100$ MHz in *Features* section
- Added Low Noise Jitter Cleaner: 2.6 ps rms typical (10 kHz to 20 MHz Integration Bandwidth), $F_C = 100$ MHz in *Features* section

1

1

Changes from Revision D (April 2011) to Revision E Page

- Changed Added, updated, or revised the following sections: *Features*; *Application and Implementation*; *Power Supply Recommendations*; *Layout*; *Device and Documentation Support*; *Mechanical, Packaging, and Ordering Information*
- Changed Bit Name from LOCKW(3) to LOCKW(2).....
- Changed Bit Name from LOCKW(2) to LOCKW(1).....
- Changed Bit Name from LOCKW(1) to LOCKW(0).....
- Changed REGISTER.BIT from 5.26 to 5.25, from 5.25 to 5.24, from 5.24 to 5.23, from 5.23 to 5.22.

1

48

48

48

48

Changes from Revision C (February, 2010) to Revision D Page

- Changed 0 to 1 in SPI_LE description
- Changed last sentence in Description column of Pin 46 and Pin 2
- Changed Outputs to Output 1 in P_{LVCMOS} Test Conditions, changed \overline{PD} to $\overline{Power_Down}$ in LVCMOS INPUT MODE, and deleted (LVCMOS signals) from Input capacitance in *Electrical Characteristics*
- Changed TIMING REQUIREMENTS table.....
- Added 1 row to TIMING Requirements table - Input Clock Slew Rate.....

4

5

7

11

11

• Added SPI CONTROL INTERFACE TIMING section	11
• Changed Functional Block Diagrams	14
• Changed pin names in Figure 11	15
• Changed Feedback Divider value in Figure 15	18
• Changed are 25°C to (nominal conditions) in Table 3	21
• Changed Poer Down state SPI Port status from ON to OFF in Table 4	22
• Changed Figure 18	23
• Changed Table 5	24
• Added note to Table 7	25
• Changed AUXSEL from X to 0 in Table 7	25
• Added note to Table 21	39
• Added new sections <i>Crystal Input Interface</i> , <i>VCO Calibration</i> , and <i>Startup Time Estimation</i>	48
• Changed Serial Peripheral Interface (SPI) section.....	55
• Changed Table 6 to Table 38 in Writing to EEPROM section	60
• Changed RAM bit 1 and RAM bit 2 in Table 43	64
• Added note and changed Smart MUX description in Table 45	66
• Changed 1 to 0 in rows PRINVBB and SECINVB6 in the description column.....	66
• Changed RAM bit 22 from 0 to 1 and changed RAM bit 24 from 0 to 1 in Table 47	68
• Changed Table 48	69

Changes from Revision B (July, 2009) to Revision C
Page

• Deleted <i>LVC MOS INPUT MODE (AUX_IN)</i> section from Electrical Characteristics table.....	7
---	---

5 Pin Configuration and Functions

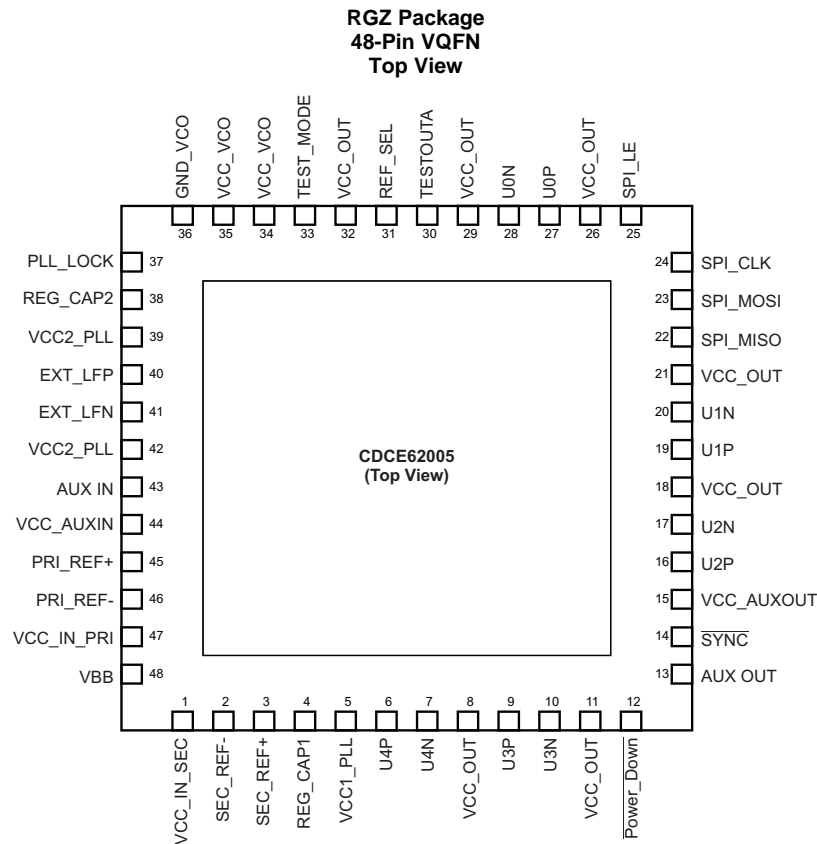

Pin Functions⁽¹⁾

PIN		TYPE	DESCRIPTION
NAME	NO,		
VCC_OUT	8, 11, 18, 21, 26, 29, 32	Power	3.3-V Supply for the Output Buffers and Output Dividers
VCC_AUXOUT	15	Power	3.3-V to Power the AUX_OUT circuitry
VCC1_PLL	5	A. Power	3.3-V PLL Supply Voltage for the PLL circuitry. (Filter Required)
VCC2_PLL	39, 42	A. Power	3.3-V PLL Supply Voltage for the PLL circuitry. (Filter Required)
VCC_VCO	34, 35	A. Power	3.3-V VCO Input Buffer and Circuitry Supply Voltage. (Filter Required)
VCC_IN_PRI	47	A. Power	3.3-V References Input Buffer and Circuitry Supply Voltage.
VCC_IN_SEC	1	A. Power	3.3-V References Input Buffer and Circuitry Supply Voltage.
VCC_AUXIN	44	A. Power	3.3-V Crystal Oscillator Input Circuitry.
GND_VCO	36	Ground	Ground that connects to VCO Ground. (VCO_GND is shorted to GND)
GND	PAD	Ground	Ground is on Thermal PAD. See Layout recommendation
SPI_MISO	22	O	3-state LVCMOS Output that is enabled when SPI_LE is asserted low. It is the serial Data Output to the SPI bus interface
SPI_LE	25	I	LVCMOS input, control Latch Enable for Serial Programmable Interface (SPI), with Hysteresis in SPI Mode. The input has an internal 150-kΩ pull-up resistor if left unconnected it will default to logic level 1. The SPI_LE status also impacts whether the device loads the EEPROM into the device registers at power up. SPI_LE has to be logic 1 before the Power_Down pin toggles low-to-high in order for the EEPROM to load properly.

(1) Note: The internal memory (EEPROM and RAM) are sourced from various power pins. All VCC connections must be powered for proper functionality of the device.

Pin Functions⁽¹⁾ (continued)

PIN		TYPE	DESCRIPTION
NAME	NO,		
SPI_CLK	24	I	LVC MOS input, serial Control Clock Input for the SPI bus interface, with Hysteresis. The input has an internal 150-k Ω pull-up resistor if left unconnected it will default to logic level 1.
SPI_MOSI	23	I	LVC MOS input, Master Out Slave In as a serial Control Data Input to CDCE62005 for the SPI bus interface. The input has an internal 150-k Ω pull-up resistor if left unconnected it will default to logic level 1.
TEST_MODE	33	I	This pin should be tied high or left unconnected.
REF_SEL	31	I	If Auto Reference Select Mode is OFF this Pin acts as External Input Reference Select Pin; The REF_SEL signal selects one of the two input clocks: REF_SEL [1]: PRI_REF is selected; REF_SEL [0]: SEC_REF is selected; The input has an internal 150-k Ω pull-up resistor if left unconnected it will default to logic level 1. If Auto Reference Select Mode in ON (for example, EECLKSEL bit -- Register 5 Bit 5 -- is 1), then REF_SEL pin input setting is ignored.
Power_Down	12	I	Active Low. Power down mode can be activated via this pin. See Table 4 for more details. The input has an internal 150-k Ω pull-up resistor if left unconnected it will default to logic level 1. SPI_LE has to be HIGH in order for the rising edge of Power_Down signal to load the EEPROM.
SYNC	14	I	Active Low. Sync mode can be activated via this pin. See Table 4 for more details. The input has an internal 150-k Ω , pull-up resistor if left unconnected it will default to logic level 1.
AUX IN	43	I	Auxiliary Input is a single ended input including an on-board oscillator circuit so that a crystal may be connected.
AUX OUT	13	O	Auxiliary Output LVC MOS level that can be programmed via SPI interface to be driven by Output 2 or Output 3.
PRI_REF+	45	I	Universal Input Buffer (LVPECL, LVDS, LVC MOS) positive input for the Primary Reference Clock.
PRI_REF-	46	I	Universal Input Buffer (LVPECL, LVDS) negative input for the Primary Reference Clock. In case of LVC MOS input on PRI_REF+, connect this pin through 1-k Ω resistor to GND.
SEC_REF+	3	I	Universal Input Buffer (LVPECL, LVDS, LVC MOS) positive input for the Secondary Reference Clock.
SEC_REF-	2	I	Universal Input Buffer (LVPECL, LVDS,) negative input for the Secondary Reference Clock. In case of LVC MOS input on SEC_REF+, connect this pin through 1-k Ω resistor to GND.
TESTOUTA	30	Analog	Reserved. Pull Down to GND Via a 1-k Ω Resistor.
REG_CAP1	4	Analog	Capacitor for the internal Regulator. Connect to a 10- μ F Capacitor (X5R or X7R)
REG_CAP2	38	Analog	Capacitor for the internal Regulator. Connect to a 10- μ F Capacitor (X5R or X7R)
VBB	48	Analog	Capacitor for the internal termination Voltage. Connect to a 1- μ F Capacitor (X5R or X7R)
EXT_LFP	40	Analog	External Loop Filter Input Positive
EXT_LFN	41	Analog	External Loop Filter Input Negative.
PLL_LOCK	37	O	Output that indicates PLL Lock Status. See Figure 31 .
U0P:U0N U1P:U1N U2P:U2N U3P:U3N U4P:U4N	27, 28 19, 20 16, 17 9, 10 6, 7	O	The Main outputs of CDCE62005 are user definable and can be any combination of up to 5 LVPECL outputs, 5 LVDS outputs or up to 10 LVC MOS outputs. The outputs are selectable via SPI interface. The power-up setting is EEPROM configurable.

6 Specifications

6.1 Absolute Maximum Ratings

over operating free-air temperature range (unless otherwise noted)⁽¹⁾

		MIN	MAX	UNIT
V _{CC}	Supply voltage range ⁽²⁾	-0.5	4.6	V
V _I	Input voltage range ⁽³⁾	-0.5	V _{CC} + 0.5	V
V _O	Output voltage range ⁽³⁾	-0.5	V _{CC} + 0.5	V
	Input Current (V _I < 0, V _I > V _{CC})		±20	mA
	Output current for LVPECL/LVCMOS Outputs (0 < V _O < V _{CC})		±50	mA
T _J	Junction temperature		125	°C
T _{stg}	Storage temperature	-65	150	°C

- (1) Stresses beyond those listed under *absolute maximum ratings* may cause permanent damage to the device. These are stress ratings only and functional operation of the device at these or any other conditions beyond those indicated *under recommended operating conditions* is not implied. Exposure to absolute–maximum–rated conditions for extended periods may affect device reliability.
- (2) All supply voltages have to be supplied simultaneously.
- (3) The input and output negative voltage ratings may be exceeded if the input and output clamp–current ratings are observed.

6.2 ESD Ratings

		MIN	MAX	UNIT
V _(ESD)	Electrostatic discharge	Human body model (HBM), per ANSI/ESDA/JEDEC JS-001, all pins ⁽¹⁾	2000	V
		Charged device model (CDM), per JEDEC specification JESD22-C101, all pins ⁽²⁾	750	

- (1) JEDEC document JEP155 states that 500-V HBM allows safe manufacturing with a standard ESD control process.
- (2) JEDEC document JEP157 states that 250-V CDM allows safe manufacturing with a standard ESD control process.

6.3 Thermal Information⁽¹⁾⁽²⁾

THERMAL METRIC ⁽³⁾		RGZ	UNIT
		48 PINS	
R _{θJA}	Junction-to-ambient thermal resistance	28.9 ⁽⁴⁾	°C/W
		20.4 ⁽⁵⁾	
		27.3 ⁽⁶⁾	
		20.3 ⁽⁷⁾	
R _{θJC(top)}	Junction-to-case (top) thermal resistance	12.9	°C/W
R _{θJB}	Junction-to-board thermal resistance	4.0	°C/W
ψ _{JT}	Junction-to-top characterization parameter	0.2	°C/W
ψ _{JB}	Junction-to-board characterization parameter	4.0	°C/W
R _{θJC(bot)}	Junction-to-case (bottom) thermal resistance	0.9	°C/W
θ _{JP}	Junction-to-pad ⁽⁸⁾	2 ⁽⁴⁾	°C/W
		2 ⁽⁵⁾	
		2 ⁽⁶⁾	
		2 ⁽⁷⁾	

- (1) The package thermal impedance is calculated in accordance with JESD 51 and JEDEC2S2P (high-k board).
- (2) Connected to GND with 36 thermal vias (0,3 mm diameter).
- (3) For more information about traditional and new thermal metrics, see the *Semiconductor and IC Package Thermal Metrics* application report, [SPRA953](#).
- (4) JEDEC Compliant Board (6X6 VIAs on PAD), Airflow = 0 LFM
- (5) JEDEC Compliant Board (6X6 VIAs on PAD), Airflow = 100 LFM
- (6) Recommended Layout (7X7 VIAs on PAD), Airflow = 0 LFM
- (7) Recommended Layout (7X7 VIAs on PAD), Airflow = 100 LFM
- (8) θ_{JP} (Junction – Pad) is used for the QFN Package, because the main heat flow is from the Junction to the GND-Pad of the QFN.

6.4 Electrical Characteristics

recommended operating conditions for the CDCE62005 device for under the specified Industrial temperature range of -40°C to 85°C

PARAMETER		TEST CONDITIONS		MIN	TYP ⁽¹⁾	MAX	UNIT
POWER SUPPLY							
V_{CC}	Supply voltage			3	3.3	3.6	V
V_{CC_PLL} , V_{CC_IN} , V_{CC_VCO} , V_{CCA}	Analog supply voltage			3	3.3	3.6	
P_{LVPECL}	REF at 30.72 MHz, Outputs are LVPECL	Output 1 = 491.52 MHz Output 2 = 245.76 MHz			1.9		W
P_{LVDS}	REF at 30.72 MHz, Outputs are LVDS	Output 3 = 122.88 MHz Output 4 = 61.44 MHz			1.65		W
P_{LVCMOS}	REF at 30.72 MHz, Outputs are LVCMOS	Output 5 = 30.72 MHz In case of LVCMOS Output1 = 245.76 MHz			1.8		W
P_{OFF}	REF at 30.72 MHz	Dividers are disabled. Outputs are disabled.			0.75		W
P_{PD}		Device is powered down			20		mW
DIFFERENTIAL INPUT MODE (PRI_REF, SEC_REF)							
V_{IN}	Differential input amplitude ($V_{IN} - V_{/IN}$)			0.1		1.3	V
V_{IC}	Common-mode input voltage			1.0		$V_{CC}-0.3$	V
I_{IH}	Differential input current high (no internal termination)	$V_I = V_{CC}$, $V_{CC} = 3.6\text{ V}$				20	μA
I_{IL}	Differential input current low (no internal termination)	$V_I = 0\text{ V}$, $V_{CC} = 3.6\text{ V}$		-20		20	μA
	Input Capacitance on PRI_REF, SEC_REF				3		pF
CRYSTAL INPUT SPECIFICATIONS							
	On-chip load capacitance				10		pF
	Equivalent series resistance (ESR)					50	Ω
LVCMOS INPUT MODE (SPI_CLK, SPI_MOSI, SPI_LE, Power_Down, SYNC, REF_SEL, PRI_REF, SEC_REF)							
	Low-level input voltage LVCMOS,			0		$0.3 \times V_{CC}$	V
	High-level input voltage LVCMOS			$0.7 \times V_{CC}$		V_{CC}	V
V_{IK}	LVCMOS input clamp voltage	$V_{CC} = 3\text{ V}$, $I_I = -18\text{ mA}$				-1.2	V
I_{IH}	LVCMOS input current	$V_I = V_{CC}$, $V_{CC} = 3.6\text{ V}$				20	μA
I_{IL}	LVCMOS input (Except PRI_REF and SEC_REF)	$V_I = 0\text{ V}$, $V_{CC} = 3.6\text{ V}$		-10		-40	μA
I_{IL}	LVCMOS input (PRI_REF and SEC_REF)	$V_I = 0\text{ V}$, $V_{CC} = 3.6\text{ V}$		-10		10	μA
C_I	Input capacitance	$V_I = 0\text{ V}$ or V_{CC}			3		pF
SPI OUTPUT (MISO) / PLL_LOCK OUTPUT							
I_{OH}	High-level output current	$V_{CC} = 3.3\text{ V}$,	$V_O = 1.65\text{ V}$		-30		mA
I_{OL}	Low-level output current	$V_{CC} = 3.3\text{ V}$,	$V_O = 1.65\text{ V}$		33		mA
V_{OH}	High-level output voltage for LVCMOS outputs	$V_{CC} = 3\text{ V}$,	$I_{OH} = -100\text{ }\mu\text{A}$	$V_{CC}-0.5$			V
V_{OL}	Low-level output voltage for LVCMOS outputs	$V_{CC} = 3\text{ V}$,	$I_{OL} = 100\text{ }\mu\text{A}$			0.3	V
C_O	Output capacitance on MISO	$V_{CC} = 3.3\text{ V}$; $V_O = 0\text{ V}$ or V_{CC} ⁽¹⁾			3		pF
I_{OZH}	3-state output current	$V_O = V_{CC}$			5		μA
I_{OZL}		$V_O = 0\text{ V}$			-5		

(1) All typical values are at $V_{CC} = 3.3\text{ V}$, temperature = 25°C

Electrical Characteristics (continued)

recommended operating conditions for the CDCE62005 device for under the specified Industrial temperature range of -40°C to 85°C

PARAMETER		TEST CONDITIONS		MIN	TYP ⁽¹⁾	MAX	UNIT
EEPROM							
EEcy	Programming cycle of EEPROM			100	1000		Cycles
EEret	Data retention			10			Years
VBB							
VBB	Termination voltage for reference inputs.	$I_{BB} = -0.2 \text{ mA}$, Depending on the setting.		0.9		1.9	V
INPUT BUFFERS INTERNAL TERMINATION RESISTORS (PRI_REF and SEC_REF)							
	Termination resistance	Single ended			50		Ω
PHASE DETECTOR							
f_{CPmax}	Charge pump frequency			0.04		40	MHz
LVC MOS OUTPUT / AUXILIARY OUTPUT⁽¹⁾							
f_{clk}	Output frequency (see Figure 7)	Load = 5 pF to GND		0		250	MHz
V_{OH}	High-level output voltage for LVC MOS outputs	$V_{CC} = \text{min to max}$	$I_{OH} = -100 \mu\text{A}$	$V_{CC} - 0.5$			
V_{OL}	Low-level output voltage for LVC MOS outputs	$V_{CC} = \text{min to max}$	$I_{OL} = 100 \mu\text{A}$			0.3	V
I_{OH}	High-level output current	$V_{CC} = 3.3 \text{ V}$	$V_O = 1.65 \text{ V}$		-30		mA
I_{OL}	Low-level output current	$V_{CC} = 3.3 \text{ V}$	$V_O = 1.65 \text{ V}$		33		mA
t_{pho}	Reference (PRI_REF or SEC_REF) to Output Phase offset	Outputs are set to 122.88 MHz, Reference at 30.72 MHz			0.35		ns
$t_{pd(LH)}/t_{pd(HL)}$	Propagation delay from PRI_REF or SEC_REF to Outputs	Crosspoint to $V_{CC}/2$, Bypass Mode			4		ns
$t_{sk(o)}$	Skew, output to output For Y0 to Y4	All Outputs set at 200 MHz, Reference = 200 MHz			75		ps
C_O	Output capacitance on Y0 to Y4	$V_{CC} = 3.3 \text{ V}; V_O = 0 \text{ V or } V_{CC}$			5		pF
I_{OZH}	3-State LVC MOS output current	$V_O = V_{CC}$			5		μA
I_{OZL}		$V_O = 0 \text{ V}$			-5		μA
I_{OPDH}	Power Down output current	$V_O = V_{CC}$				25	μA
I_{OPDL}		$V_O = 0 \text{ V}$				5	μA
	Duty cycle LVC MOS			45%		55%	
$t_{slew-rate}$	Output rise/fall slew rate			3.6	5.2		V/ns

Electrical Characteristics (continued)

recommended operating conditions for the CDCE62005 device for under the specified Industrial temperature range of –40°C to 85°C

PARAMETER		TEST CONDITIONS	MIN	TYP ⁽¹⁾	MAX	UNIT
LVDS OUTPUT⁽¹⁾⁽²⁾						
f_{clk}	Output frequency (see Figure 8)	Configuration Load	0		800	MHz
$ V_{OD} $	Differential output voltage	$R_L = 100 \Omega$	270		550	mV
ΔV_{OD}	LVDS VOD magnitude change				50	mV
	Offset Voltage	40°C to 85°C		1.24		V
ΔV_{OS}	VOS magnitude change			40		mV
	Short circuit V_{out+} to ground	$V_{OUT} = 0$			27	mA
	Short circuit V_{out-} to ground	$V_{OUT} = 0$			27	mA
t_{pho}	Reference (PRI_REF or SEC_REF) to output phase offset	Outputs are set to 491.52 MHz Reference at 30.72 MHz		1.65		ns
$t_{pd(LH)}/t_{pd(HL)}$	Propagation delay from PRI_REF or SEC_REF to outputs	Crosspoint to Crosspoint, Bypass Mode		3.1		ns
$t_{sk(o)}$ ⁽³⁾	Skew, output to output For Y0 to Y4	All Outputs set at 200 MHz		25		ps
C_O	Output capacitance on Y0 to Y4	$V_{CC} = 3.3 V$; $V_O = 0 V$ or V_{CC}		5		pF
I_{OPDH}	Power down output current	$V_O = V_{CC}$			25	μA
I_{OPDL}	Power down output current	$V_O = 0 V$			5	μA
	Duty cycle		45%		55%	
t_r / t_f	Rise and fall time	20% to 80% of $V_{OUT(PP)}$	110	160	190	ps
LVC MOS-TO-LVDS⁽⁴⁾						
t_{skP_c}	Output skew between LVC MOS and LVDS outputs	$V_{CC}/2$ to Crosspoint. Output are at the same output frequency and use the same output divider configuration.	0.9	1.4	1.9	ns
LVPECL OUTPUT						
f_{clk}	Output frequency, Configuration load (see Figure 9 and Figure 10)		0		1500	MHz
V_{OH}	LVPECL high-level output voltage load		$V_{CC} - 1.06$		$V_{CC} - 0.88$	V
V_{OL}	LVPECL low-level output voltage load		$V_{CC} - 2.02$		$V_{CC} - 1.58$	V
$ V_{OD} $	Differential output voltage		610		970	mV
t_{pho}	Reference to Output Phase offset	Outputs are set to 491.52 MHz, Reference at 30.72 MHz		1.47		ns
$t_{pd(LH)}/t_{pd(HL)}$	Propagation delay from PRI_REF or SEC_REF to outputs	Crosspoint to Crosspoint, Bypass Mode		3.4		ns
$t_{sk(o)}$	Skew, output to output For Y0 to Y4	All Outputs set at 200 MHz		25		ps
C_O	Output capacitance on Y0 to Y4	$V_{CC} = 3.3 V$; $V_O = 0 V$ or V_{CC}		5		pF
I_{OPDH}	Power Down output current	$V_O = V_{CC}$			25	μA
I_{OPDL}	Power Down output current	$V_O = 0 V$			5	μA
	Duty Cycle		45%		55%	
t_r / t_f	Rise and fall time	20% to 80% of $V_{OUT(PP)}$	55	75	135	ps

(2) The phase of LVC MOS is lagging in reference to the phase of LVDS.

(3) The $t_{sk(o)}$ specification is only valid for equal loading of all outputs.

(4) All typical values are at $V_{CC} = 3.3 V$, temperature = 25°C

Electrical Characteristics (continued)

recommended operating conditions for the CDCE62005 device for under the specified Industrial temperature range of -40°C to 85°C

PARAMETER		TEST CONDITIONS	MIN	TYP ⁽¹⁾	MAX	UNIT
LVDS-TO-LVPECL						
t_{skP_C}	Output skew between LVDS and LVPECL outputs	Crosspoint to Crosspoint output dividers are configured identically.	0.9	1.1	1.3	ns
LVC MOS-TO-LVPECL						
t_{skP_C}	Output skew between LVC MOS and LVPECL outputs	$V_{\text{CC}}/2$ to Crosspoint output dividers are configured identically.	-150	260	700	ps
LVPECL HI-SWING OUTPUT						
V_{OH}	LVPECL high-level output voltage load		$V_{\text{CC}} - 1.11$		$V_{\text{CC}} - 0.87$	V
V_{OL}	LVPECL low-level output voltage load		$V_{\text{CC}} - 2.06$		$V_{\text{CC}} - 1.73$	V
$ V_{\text{OD}} $	Differential output voltage		760		1160	mV
t_r / t_f	Rise and fall time	20% to 80% of $V_{\text{OUT(PP)}}$	55	75	135	ps

6.5 Timing Requirements

over recommended ranges of supply voltage, load and operating free air temperature (unless otherwise noted)

		MIN	NOM	MAX	UNIT
PRI_REF/SEC_REF REQUIREMENTS					
f_{max}	Maximum Clock Frequency Applied to PRI_REF and SEC_REF in fan-out mode			1500	MHz
	Maximum Clock Frequency Applied to Smart Multiplexer input Divider			500	MHz
	Maximum Clock Frequency Applied to Reference Divider			250	MHz
	For Single ended Inputs (LVCMOS) on PRI_REF and SEC_REF			250	MHz
	Duty cycle of PRI_REF or SEC_REF at $V_{CC} / 2$	40%		60%	
	Input Clock Slew Rate (Differential and Single ended)	1			V/ns
Power_Down, SYNC, REF_SEL REQUIREMENTS					
t_r / t_f	Rise and fall time of the Power_Down, SYNC, REF_SEL signal from 20% to 80% of V_{CC}			4	ns

6.6 SPI Bus Timing Characteristics

		MIN	NOM	MAX	UNIT
f_{Clock}	Clock Frequency for the SPI_CLK			20	MHz
t_1	SPI_LE to SPI_CLK setup time	See Figure 1 and Figure 2	10		ns
t_2	SPI_MOSI to SPI_CLK setup time	See Figure 1 and Figure 2	10		ns
t_3	SPI_MOSI to SPI_CLK hold time	See Figure 1 and Figure 2	10		ns
t_4	SPI_CLK high duration	See Figure 1 and Figure 2	25		ns
t_5	SPI_CLK low duration	See Figure 1 and Figure 2	25		ns
t_6	SPI_CLK to SPI_LE Hold time	See Figure 1 and Figure 2	10		ns
t_7	SPI_LE Pulse Width	See Figure 1 and Figure 2	20		ns
t_8	SPI_CLK to MISO data valid	See Figure 2		10	ns
t_9	SPI_LE to SPI_MISO Data Valid	See Figure 2		10	ns

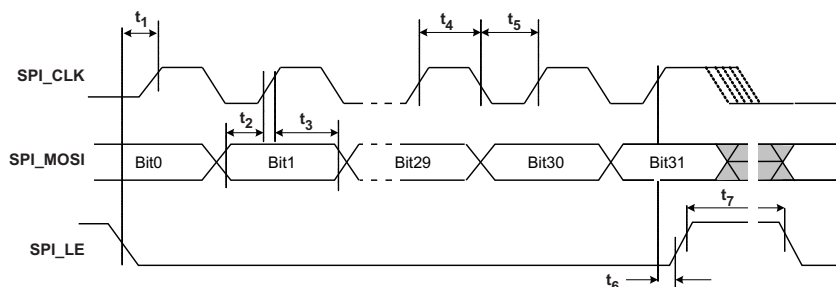

Figure 1. Timing Diagram for SPI Write Command

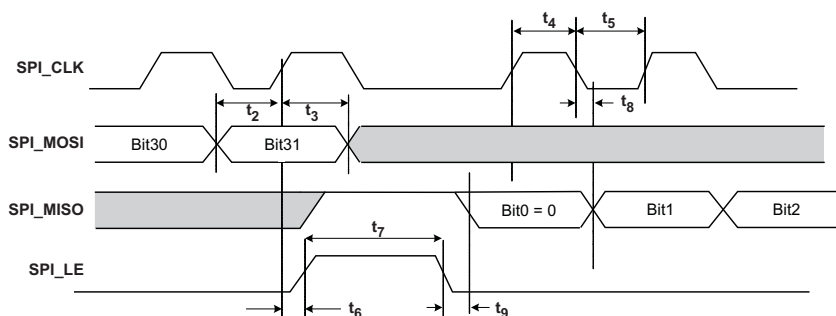
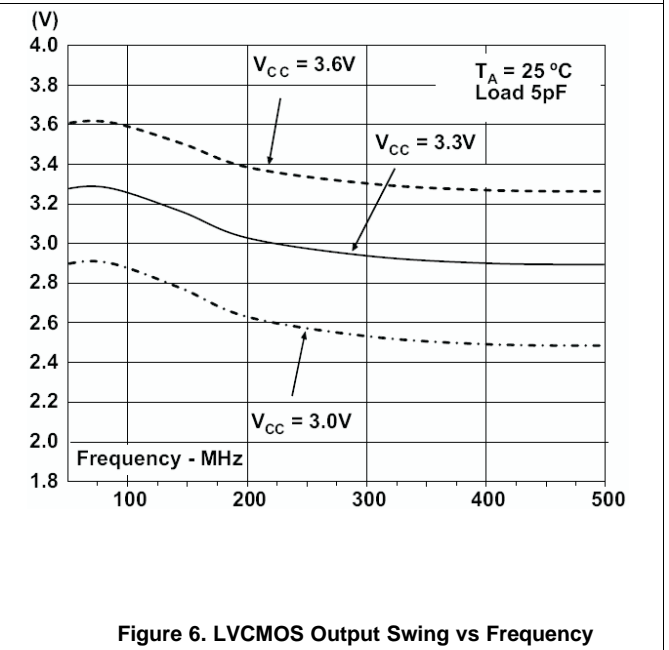
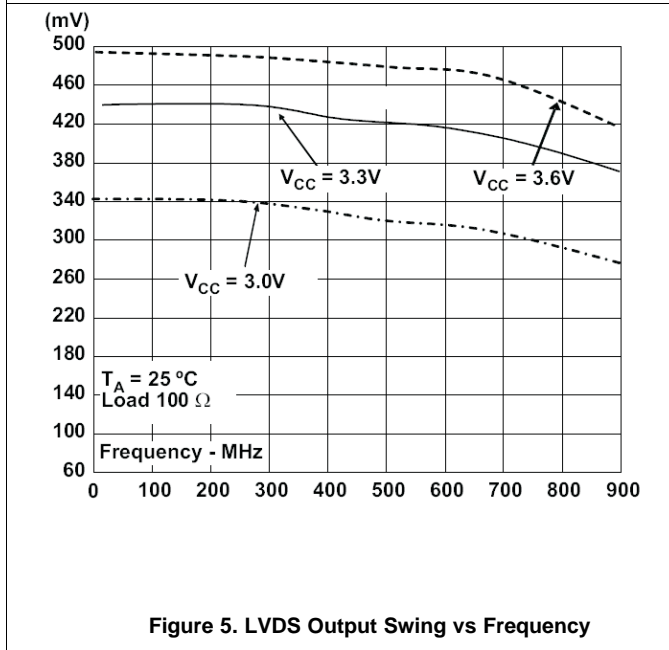
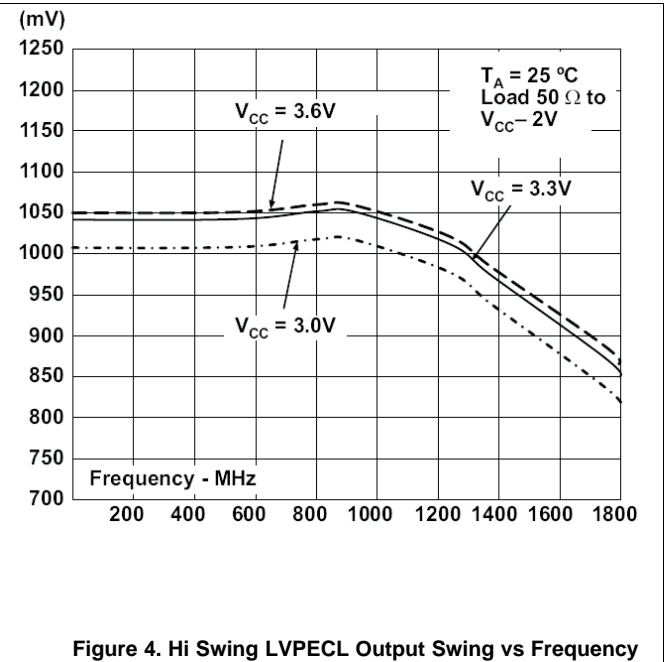
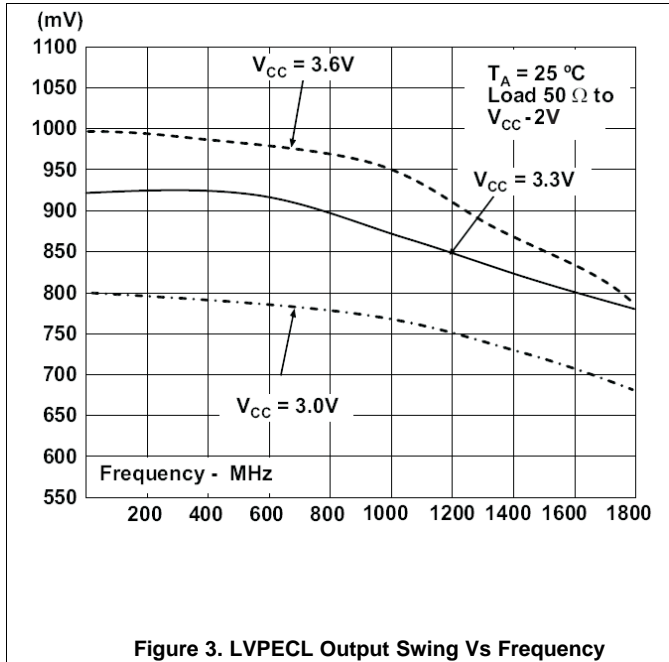

Figure 2. Timing Diagram for SPI Read Command

6.7 Typical Characteristics



7 Parameter Measurement Information

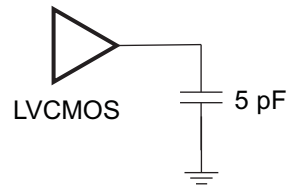

Figure 7. LVC MOS, 5 pF

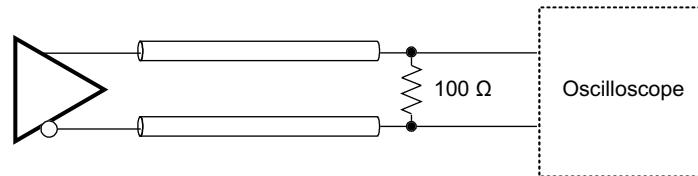

Figure 8. LVDS DC Termination Test

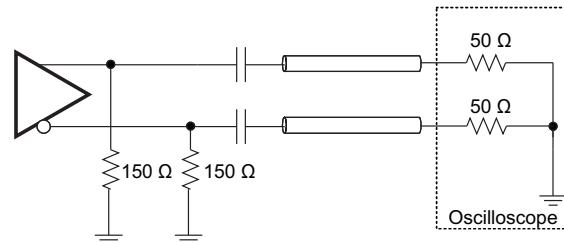

Figure 9. LVPECL AC Termination Test

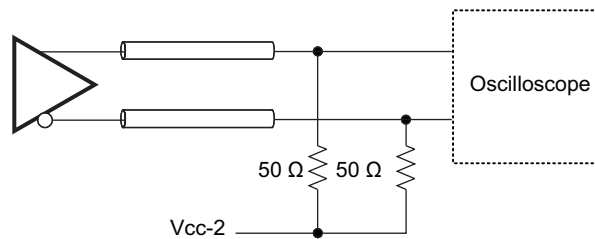

Figure 10. LVPECL DC Termination Test

8 Detailed Description

8.1 Overview

The CDCE62005 comprises of four primary blocks: the interface and control block, the input block, the output block, and the synthesizer block. In order to determine which settings are appropriate for any specific combination of input/output frequencies, a basic understanding of these blocks is required. The interface and control block determines the state of the CDCE62005 at power-up based on the contents of the on-chip EEPROM. In addition to the EEPROM, the SPI port is available to configure the CDCE62005 by writing directly to the device registers after power-up. The input block selects which of the three input ports is available for use by the synthesizer block and buffers all clock inputs. The output block provides five separate clock channels that are fully programmable and configurable to select and condition one of four internal clock sources. The synthesizer block multiplies and filters the input clock selected by the input block.

NOTE

This section provides a high-level description of the features of the CDCE62005 for purpose of understanding its capabilities. For a complete description of device registers and I/O, please refer to [Device Configuration](#) and [Register Maps](#).

8.2 Functional Block Diagrams

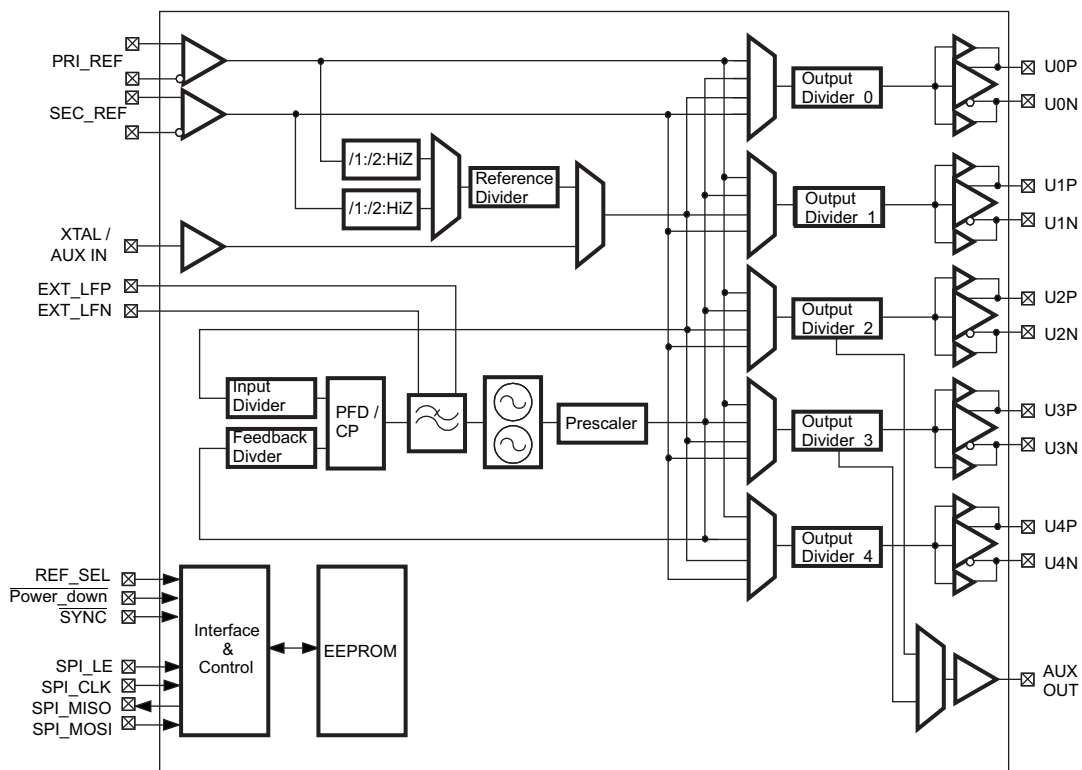

Functional Block Diagrams (continued)

8.2.1 Interface and Control Block

The CDCE62005 is a highly flexible and configurable architecture and as such contains a number of registers so that the user may specify device operation. The contents of nine 28-bit wide registers implemented in static RAM determine device configuration at all times. On power-up, the CDCE62005 copies the contents of the EEPROM into the RAM and the device begins operation based on the default configuration stored in the EEPROM. Systems that do not have a host system to communicate with the CDCE62005 use this method for device configuration. The CDCE62005 provides the ability to lock the EEPROM; enabling the designer to implement a fault tolerant design. After power-up, the host system may overwrite the contents of the RAM via the SPI (Serial Peripheral Interface) port. This enables the configuration and reconfiguration of the CDCE62005 during system operation. Finally, the device offers the ability to copy the contents of the RAM into EEPROM, if the EEPROM is unlocked.

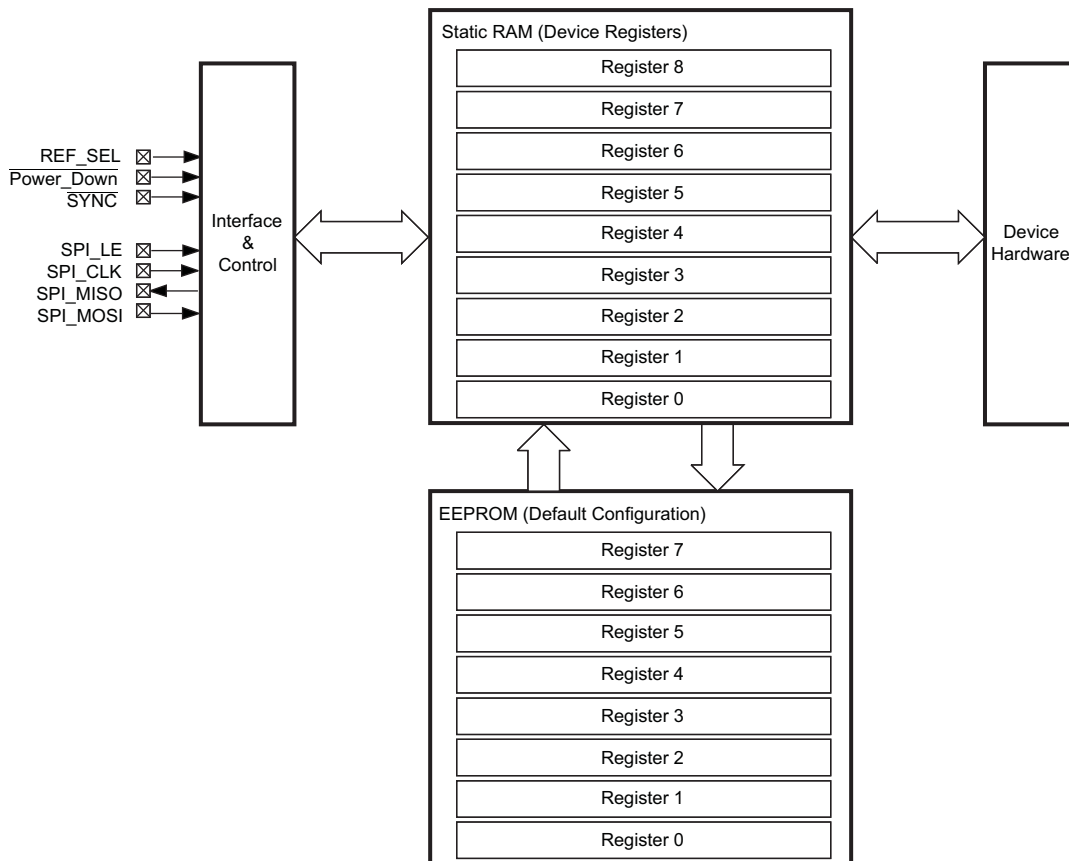

Figure 11. CDCE62005 Interface and Control Block

Functional Block Diagrams (continued)

8.2.2 Input Block

The Input Block includes a pair of Universal Input Buffers and an Auxiliary Input. The Input Block buffers the incoming signals and facilitates signal routing to the Internal Clock Distribution bus and the Synthesizer Block via the smart multiplexer (called the Smart MUX). The Internal Clock Distribution Bus connects to all output blocks discussed in the next section. Therefore, a clock signal present on the Internal Clock Distribution bus can appear on any or all of the device outputs. The CDCE62005 routes the PRI_REF and SEC_REF inputs directly to the Internal Clock Distribution Bus. Additionally, it can divide these signals via the dividers present on the inputs and output of the first stage of the Smart MUX.

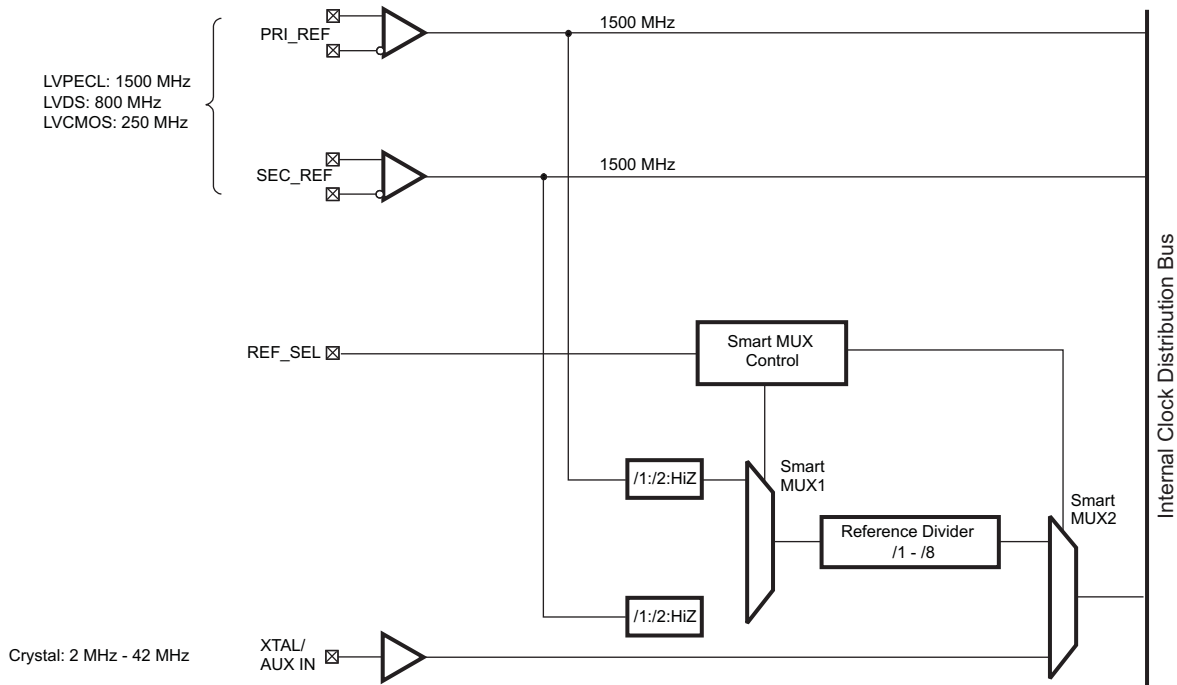

Figure 12. CDCE62005 Input Block

Functional Block Diagrams (continued)

8.2.3 Output Block

Each of the five identical output blocks incorporates an output multiplexer, a clock divider module, and a universal output array as shown.

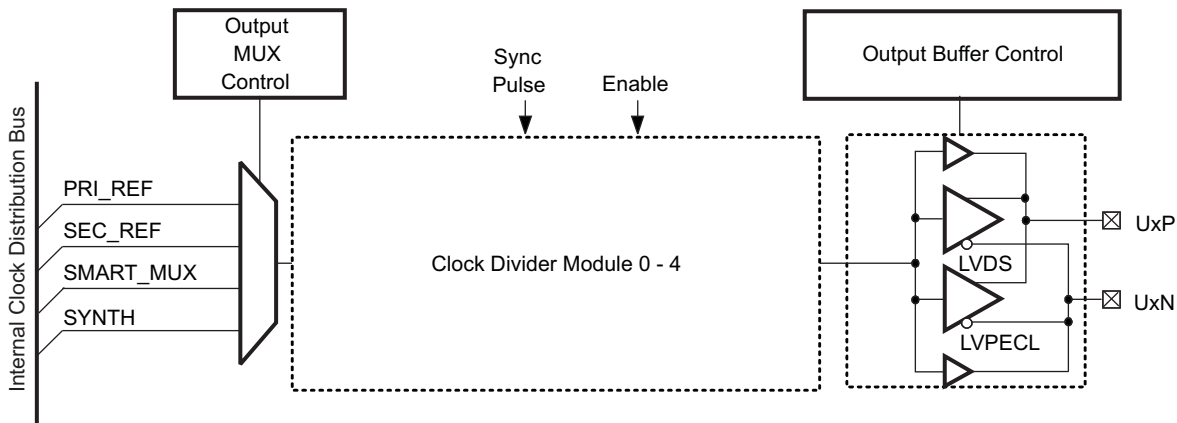

Figure 13. CDCE62005 Output Block (1 of 5)

8.2.4 Clock Divider Module 0–4

The following shows a simplified version of a Clock Divider Module (CDM). If an individual clock output channel is not used, then the user should disable the CDM and Output Buffer for the unused channel to save device power. Each channel includes two 7-bit registers to control the divide ratio used and the clock phase for each output. The output divider supports divide ratios from divide by 1 (bypass the divider) to divide by 80; the divider does not support all integer values between 1 and 80. Refer to [Table 13](#) for a complete list of divide ratios supported.

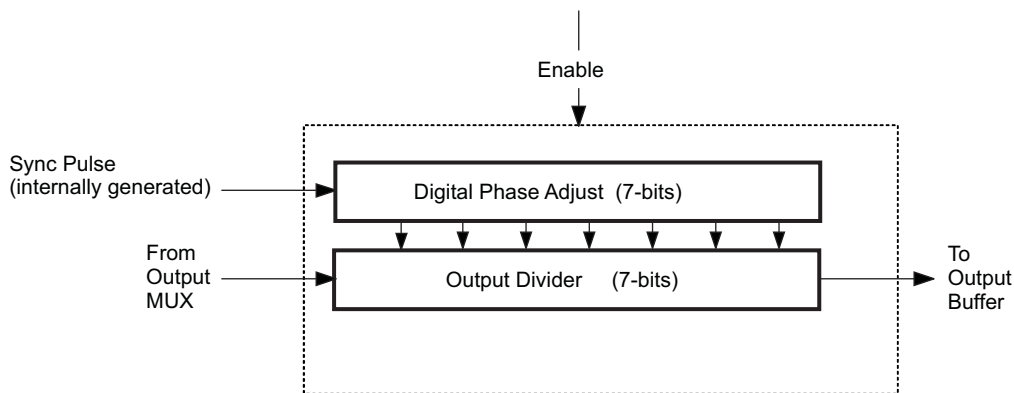

Figure 14. CDCE62005 Output Divider Module (1 of 5)

Functional Block Diagrams (continued)

8.2.5 Synthesizer Block

Figure 15 presents a high-level overview of the Synthesizer Block on the CDCE62005.

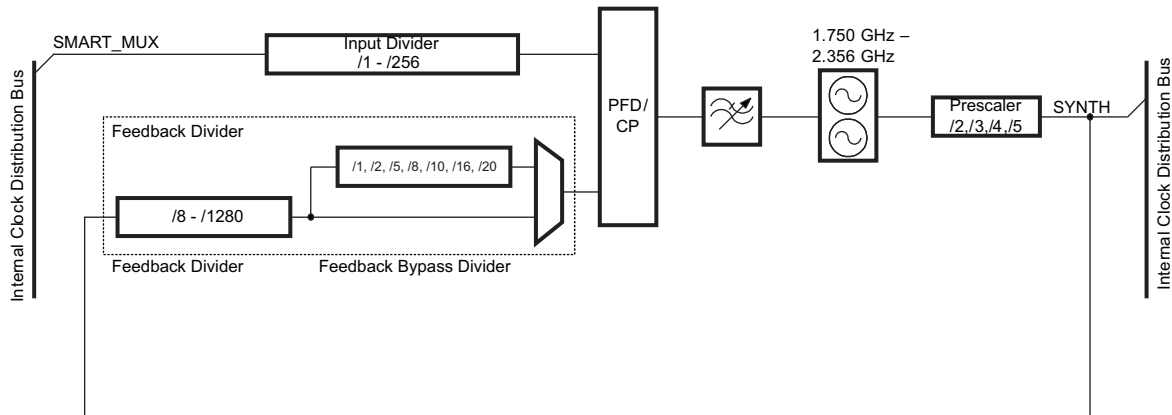

Figure 15. CDCE62005 Synthesizer Block

8.2.6 Computing The Output Frequency

Figure 16 shows the block diagram of the CDCE62005 in synthesizer mode highlighting the clock path for a single output. It also identifies the following regions containing dividers comprising the complete clock path

- R: Includes the cumulative divider values of all dividers included from the Input Ports to the output of the Smart Multiplexer (see [Input Block](#) for more details)
- O: The output divider value (see [Figure 18](#) in [Output Block](#) for more details)
- I: The input divider value (see [Synthesizer Block](#) for more details)
- P: The prescaler divider value (see [Synthesizer Block](#) for more details)
- F: The cumulative divider value of all dividers falling within the feedback divider (see [Synthesizer Block](#) for more details)

Functional Block Diagrams (continued)

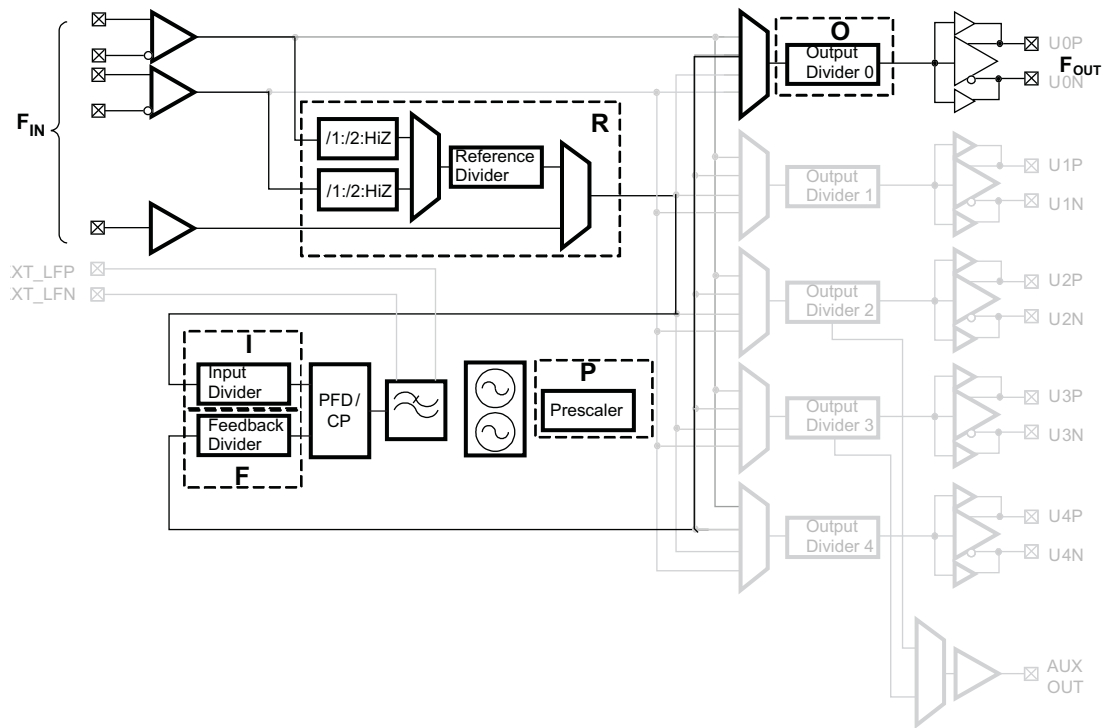

Figure 16. CDCE62005 Clock Path – Synthesizer Mode

With respect to Figure 16, any output frequency generated by the CDCE62005 relates to the input frequency connected to the Synthesizer Block by Equation 1.

$$F_{OUT} = F_{IN} \times \frac{F}{R \times I \times O} \tag{1}$$

Equation 1 holds true when subject to the following constraints:

$$1.750 \text{ GHz} < O \times P \times F_{OUT} < 2.356 \text{ GHz} \tag{2}$$

The comparison frequency F_{COMP} is:

$$40 \text{ kHz} \leq F_{COMP} < 40 \text{ MHz} \tag{3}$$

where:

$$F_{COMP} = \frac{F_{IN}}{R \times I} \tag{4}$$

NOTE

This device cannot output the frequencies between 785 MHz to 875 MHz

8.3 Feature Description

8.3.1 Phase Noise Analysis

Table 1. Device Output Phase Noise for 30.72 MHz External Reference⁽¹⁾

PHASE NOISE	REFERENCE 30.72 MHz	LVPECL 491.52 MHz	LVDS 491.52 MHz	LVC MOS 122.88 MHz	UNIT
10 Hz	-108	-81	-81	-92	dBc/Hz
100 Hz	-130	-94	-96	-108	dBc/Hz
1 kHz	-134	-106	-106	-118	dBc/Hz
10 kHz	-152	-119	-119	-132	dBc/Hz
100 kHz	-156	-121	-122	-134	dBc/Hz
1 MHz	-157	-131	-131	-143	dBc/Hz
10 MHz	—	-145	-144	-150	dBc/Hz
20 MHz	—	-145	-144	-150	dBc/Hz
Jitter(RMS) 10k~20 MHz	193 (10 kHz – 1 MHz)	307	315	377	fs

(1) Phase Noise Specifications under following configuration: VCO = 1966.08 MHz, REF = 30.72 MHz, PFD Frequency = 30.72 MHz, Charge Pump Current = 1.5 mA Loop BW = 400 kHz at 3.3 V and 25°C

Table 2. Device Output Phase Noise for 25 MHz Crystal Reference⁽¹⁾

PHASE NOISE	LVPECL 500 MHz	LVDS 250 MHz	LVC MOS 125 MHz	UNIT
10 Hz	-57	-62	-68	dBc/Hz
100 Hz	-90	-95	-102	dBc/Hz
1 kHz	-107	-113	-119	dBc/Hz
10 kHz	-115	-122	-128	dBc/Hz
100 kHz	-118	-124	-130	dBc/Hz
1 MHz	-130	-137	-143	dBc/Hz
10 MHz	-145	-147	-150	dBc/Hz
20 MHz	-145	-147	-150	dBc/Hz
Jitter(RMS) 10k~20 MHz	389	405	437	fs

(1) Phase Noise Specifications under following configuration: VCO = 2000.00 MHz, AUX IN = 25.00 MHz, PFD Frequency = 25.00 MHz, Charge Pump Current = 1.5 mA Loop BW = 400 kHz at 3.3 V and 25°C

8.3.2 Output To Output Isolation

Table 3. Output to Output Isolation⁽¹⁾

			SPUR	UNIT
Output 2	Measured Channel	In LVPECL Signaling 15.5 MHz	-67	db
Output 2	Measured Channel	In LVPECL Signaling 93 MHz	-60	db
Output 2	Measured Channel	In LVPECL Signaling 930 MHz	-59	db
Output 0	Aggressor Channel	LVPECL 22.14 MHz		
Output 1	Aggressor Channel	LVPECL 22.14 MHz		
Output 3	Aggressor Channel	LVPECL 22.14 MHz		
Output 4	Aggressor Channel	LVPECL 22.14 MHz		

(1) The Output to Output Isolation was tested under following settings (nominal conditions)

8.3.3 Device Control

Figure 17 provides a conceptual explanation of the CDCE62005 Device operation. Table 4 defines how the device behaves in each of the operational states.

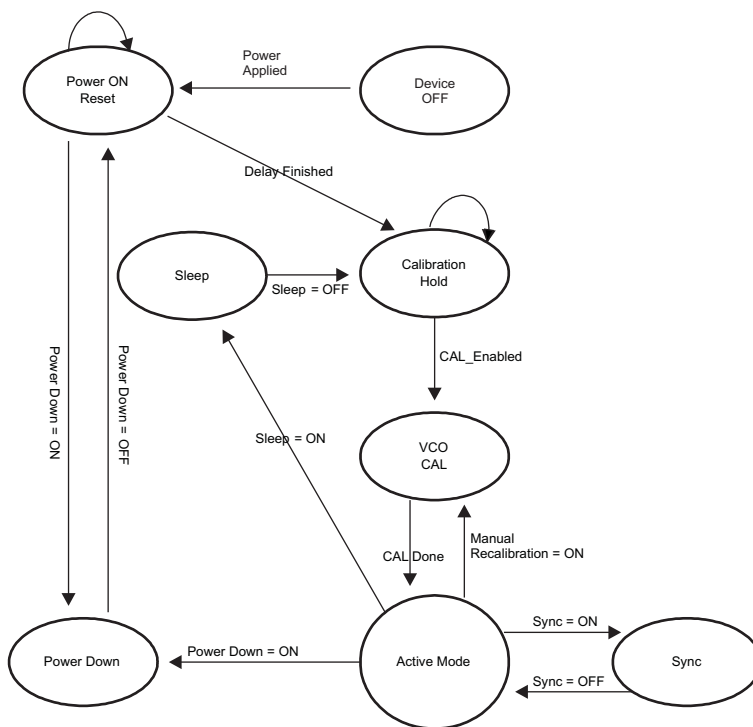

Figure 17. CDCE62005 Device State Control Diagram

Table 4. CDCE62005 Device State Definitions

STATE	DEVICE BEHAVIOR	ENTERED VIA	EXITED VIA	STATUS			
				SPI PORT	PLL	OUTPUT DIVIDER	OUTPUT BUFFER
Power-On Reset	After device power supply reaches approximately 2.35 V, the contents of EEPROM are copied into the Device Registers within 100ns, thereby initializing the device hardware.	Power applied to the device or upon exit from Power Down State via the Power_Down pin set HIGH.	Power On Reset and EEPROM loading delays are finished OR the Power_Down pin is set LOW.	OFF	Disabled	Disabled	OFF
Calibration Hold	The device waits until either ENCAL_MODE (Device Register 6 bit 27) is low (Start up calibration enabled) or both ENCAL_MODE is high (Manual Calibration Enabled) AND ENCAL (Device Register 6 bit 22) transitions from a low to a high signaling the device.	Delay process in the Power-On Reset State is finished or Sleep Mode (Sleep bit is in Register 8 bit 7) is turned OFF while in the Sleep State. Power Down must be OFF to enter the Calibration Hold State.	The device waits until either ENCAL_MODE (Device Register 6 bit 27) is low (Start up calibration enabled) or both ENCAL_MODE is high (Manual Calibration Enabled) AND ENCAL (Device Register 6 bit 22) transitions from a low to a high signaling the device	ON	Enabled	Disabled	OFF
VCO CAL	The voltage controlled oscillator is calibrated based on the PLL settings and the incoming reference clock. After the VCO has been calibrated, the device enters Active Mode automatically.	Calibration Hold: CAL Enabled becomes true when either ENCAL_MODE (Device Register 6 bit 27) is low or both ENCAL_MODE is high AND ENCAL (Device Register 6 bit 22) transitions from a low to a high. Active Mode: A Manual Recalibration is requested. This is initiated by setting ENCAL_MODE to HIGH (Manual Calibration Enabled) AND initiating a calibration sequence by applying a LOW to HIGH transition on ENCAL.	Calibration Process in completed	ON	Enabled	Disabled	OFF
Active Mode	Normal Operation	CAL Done (VCO calibration process finished) or Sync = OFF (from Sync State).	Sync, Power Down, Sleep, or Manual Recalibration activated.	ON	Enabled	Disabled or Enabled	HI-Z or Enabled
Power Down	Used to shut down all hardware and Resets the device after exiting the Power Down State. Therefore, the EEPROM contents will eventually be copied into RAM after the Power Down State is exited.	Power_Down pin is pulled LOW.	Power_Down pin is pulled HIGH.	OFF	Disabled	Disabled	HI-Z
Sleep	Identical to the Power Down State except the EEPROM contents are not copied into RAM.	Sleep bit in device register 8 bit 7 is set LOW.	Sleep bit in device register 8 bit 7 is set HIGH.	ON	Disabled	Disabled	HI-Z
Sync	Sync synchronizes all output dividers so that they begin counting at the same time. Note: this operation is performed automatically each time a divider register is accessed.	Sync Bit in device register 8 bit 8 is set LOW or Sync pin is pulled LOW	Sync Bit in device register 8 bit 8 is set HIGH or Sync pin is pulled HIGH	ON	Enabled	Disabled	HI-Z

8.3.4 External Control Pins

REF_SEL REF_SEL provides a way to switch between the primary and secondary reference inputs (PRI_REF and SEC_REF) via an external signal. It works in conjunction with the smart multiplexer discussed in [Input Block](#).

Power_Down The Power_Down pin places the CDCE62005 into the power down state.

The CDCE62005 loads the contents of the EEPROM into RAM after the Power_Down pin is de-asserted; therefore, it is used to initialize the device after power is applied. SPI_LE signal has to be HIGH in order for EEPROM to load correctly during the rising edge of Power_Down.

SYNC The SYNC pin (Active LOW) has a complementary register location located in Device Register 8 bit 8.

When enabled, Sync synchronizes all output dividers so that they begin counting simultaneously. Further, SYNC disables all outputs when in the active state.

NOTE

The output synchronization does not work for reference input frequencies less than 1 MHz.

8.3.5 Input Block

The Input Block includes two Universal Input Buffers, an Auxiliary Input, and a Smart Multiplexer. The Input Block drives three different clock signals onto the Internal Clock Distribution Bus: buffered versions of both the primary and secondary inputs (PRI_REF and SEC_REF) and the output of the Smart Multiplexer.

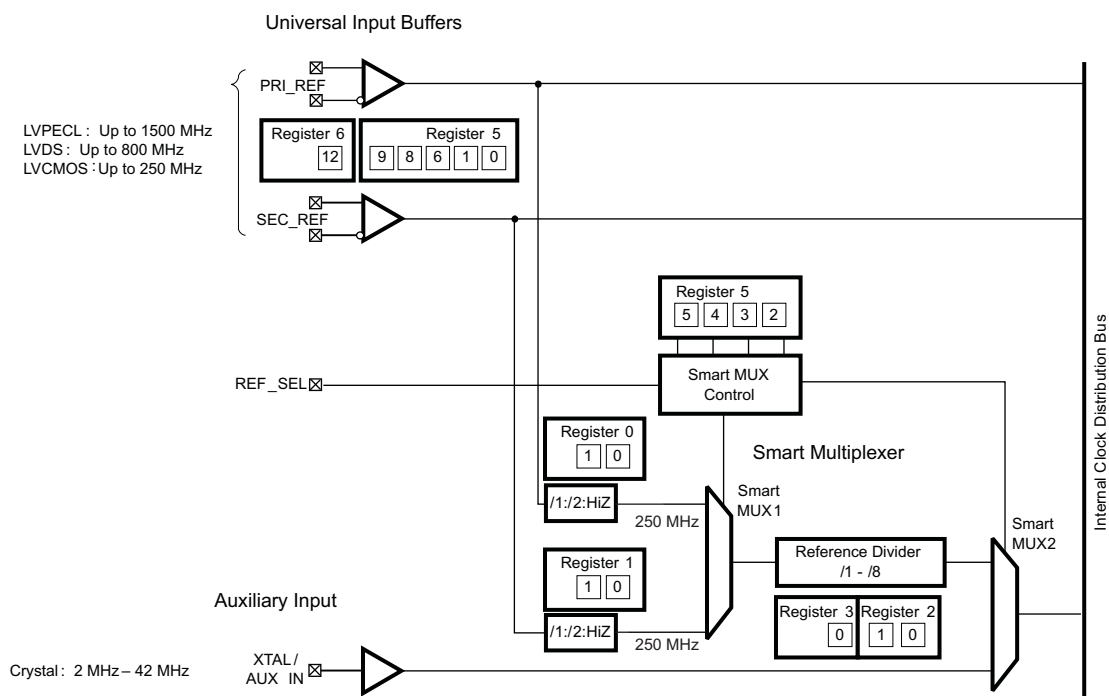

Figure 18. CDCE62005 Input Block With References to Registers

8.3.5.1 Universal Input Buffers (UIB)

Figure 19 shows the key elements of a universal input buffer. A UIB supports multiple formats along with different termination and coupling schemes. The CDCE62005 implements the UIB by including on board switched termination, a programmable bias voltage generator, and an output multiplexer. The CDCE62005 provides a high degree of configurability on the UIB to facilitate most existing clock input formats.

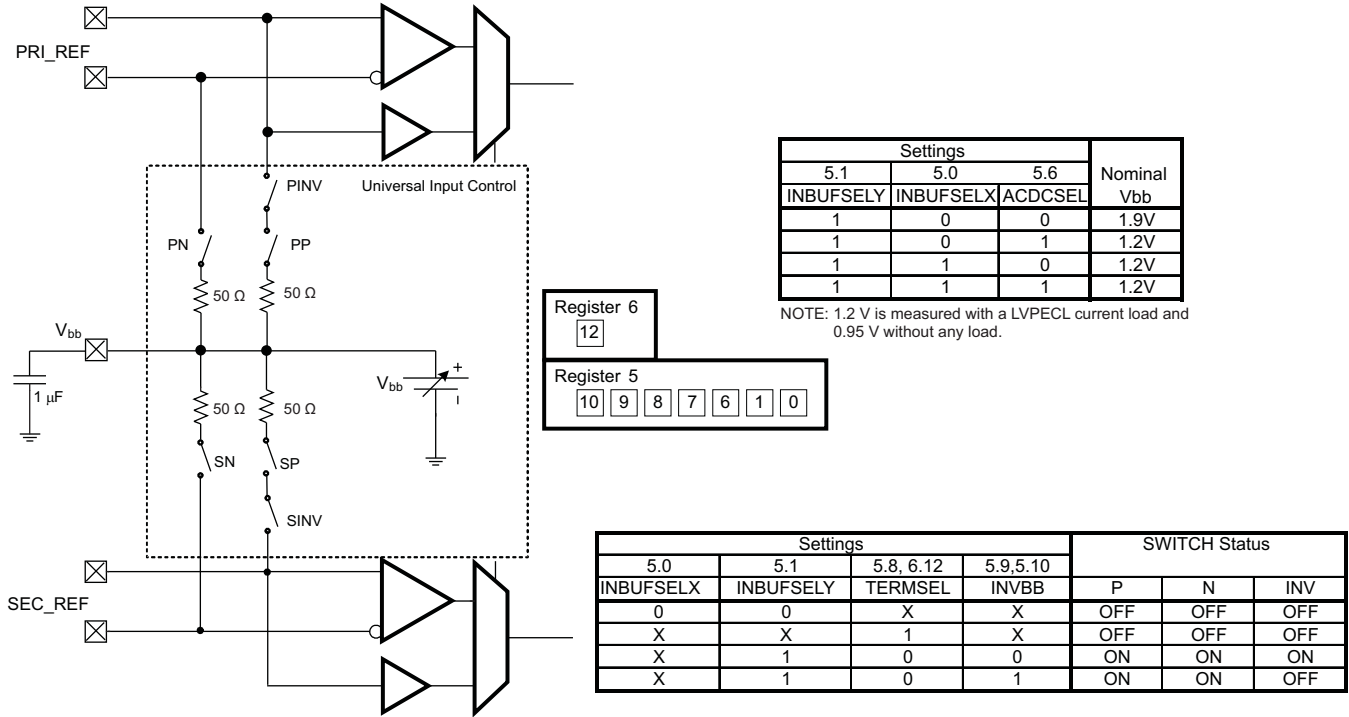

Figure 19. CDCE62005 Universal Input Buffer

Switch PP and PN will be closed only if 5.8=0 and 5.0=1 or 5.1=1.

Switch PINV will be closed only if 5.9=0 and switch SINV will be closed only if R5.10=0.

Register 5.0 and 5.6 together pick the V_{bb} voltage.

Table 5 lists several settings for many possible clock input scenarios. Note that the two universal input buffers share the V_{bb} generator. Therefore, if both inputs use internal termination, they must use the same configuration mode (LVDS, LVPECL, or LVCMOS). If the application requires different modes (for example, LVDS and LVPECL) then one of the two inputs must implement external termination.

Table 5. CDCE62005 Universal Input Buffer Configuration Matrix

PRI_REF CONFIGURATION MATRIX											
Register.Bit →	5.7	5.1	5.0	5.8	5.9	5.6					
Bit Name →	HYSTEN	INBUFSELY	INBUFSELX	PRI_TERMSEL	PRINVB	ACDCSEL	HYSTERESIS	MODE	COUPLING	TERMINATION	V _{bb}
	1	0	0	X	X	X	ENABLED	LVCMOS	DC	N/A	—
	1	1	0	0	0	0	ENABLED	LVPECL	AC	Internal	1.9V
	1	1	0	0	0	1	ENABLED	LVPECL	DC	Internal	1.2V ⁽¹⁾
	1	1	0	1	X	X	ENABLED	LVPECL	—	External	—
	1	1	1	0	0	0	ENABLED	LVDS	AC	Internal	1.2V
	1	1	1	0	0	1	ENABLED	LVDS	DC	Internal	1.2V
	1	1	1	1	X	X	ENABLED	LVDS	—	External	—
	0	X	X	X	X	X	OFF	—	—	—	—
	1	X	X	X	X	X	ENABLED	—	—	—	—

(1) 0.95V unloaded

Table 5. CDCE62005 Universal Input Buffer Configuration Matrix (continued)

PRI_REF CONFIGURATION MATRIX											
SEC_REF CONFIGURATION MATRIX											
Register.Bit →	SETTINGS						CONFIGURATION				
	5.7	5.1	5.0	6.12	5.10	5.6					
Bit Name →	HYSTEN	INBUFSELY	INBUFSELX	SEC_TERMSEL	SECINVBB	ACDCSEL	Hysteresis	Mode	Coupling	Termination	Vbb
	1	0	0	X	X	X	ENABLED	LVCNOS	DC	N/A	—
	1	1	0	0	0	0	ENABLED	LVPECL	AC	Internal	1.9V
	1	1	0	0	0	1	ENABLED	LVPECL	DC	Internal	1.2V ⁽¹⁾
	1	1	0	1	X	X	ENABLED	LVPECL	—	External	—
	1	1	1	0	0	0	ENABLED	LVDS	AC	Internal	1.2V
	1	1	1	0	0	1	ENABLED	LVDS	DC	Internal	1.2V
	1	1	1	1	X	X	ENABLED	LVDS	—	External	—
	0	X	X	X	X	X	OFF	—	—	—	—
	1	X	X	X	X	X	ENABLED	—	—	—	—

8.3.5.2 LVDS Fail Safe Mode

Differential receivers can switch on noise in the absence of an input signal. This occurs when the clock driver is turned off or the interconnect is damaged or missing. The traditional solution to this problem involves incorporating an external resistor network on the receiver input. This network applies a steady-state bias voltage to the input pins. The additional cost of the external components notwithstanding, the use of such a network lowers input signal magnitude and thus reduces the differential noise margin. The CDCE62005 provides internal failsafe circuitry on all LVDS inputs if enabled as shown in [Table 6](#) for DC termination only.

Table 6. LVDS Failsafe Settings

BIT NAME → REGISTER.BIT →	FAILSAFE 5.11	LVDS FAILSAFE
	0	Disabled for all inputs
	1	Enabled for all inputs

8.3.5.3 Smart Multiplexer Controls

The smart multiplexer implements a configurable switching mechanism suitable for many applications in which fault tolerance is a design consideration. It includes the multiplexer itself along with three dividers. With respect to the multiplexer control, [Table 7](#) provides an overview of the configurations supported by the CDCE62005.

Table 7. CDCE62005 Smart Multiplexer Settings

REGISTER 5 SETTINGS				SMART MULTIPLEXER MODE
EECLKSEL	AUXSEL	SECSEL	PRISEL	
5.5	5.4	5.3	5.2	
1	0	0	1	Manual Mode: PRI_REF selected
1	0	1	0	Manual Mode: SEC_REF selected
1	1	0	0	Manual Mode: AUX IN selected
1	0	1	1	Auto Mode: PRI_REF then SEC_REF
1	1	1	1	Auto Mode: PRI_REF then SEC_REF then AUX IN ⁽¹⁾
0	0	1	1	REF_SEL pin selects PRI_REF or SEC_REF

(1) For this mode of operation, a crystal must be connected to the AUX IN input pin.

8.3.5.4 Smart Multiplexer Auto Mode

Smart Multiplexer Auto Mode switches automatically between clock inputs based on a prioritization scheme shown in [Table 7](#). If using the Smart Multiplexer Auto Mode, the frequencies of the clock inputs may differ by up to 20%. The phase relationship between clock inputs has no restriction.

Upon the detection of a loss of signal on the highest priority clock, the smart multiplex switches its output to the next highest priority clock on the first incoming rising edge of the next highest priority clock. During this switching operation, the output of the smart multiplexer is low. Upon restoration of the higher priority clock, the smart multiplexer waits until it detects four complete cycles from the higher priority clock prior to switching the output of the smart multiplexer back to the higher priority clock. During this switching operation, the output of the smart multiplexer remains high until the next falling edge as shown in [Figure 20](#).

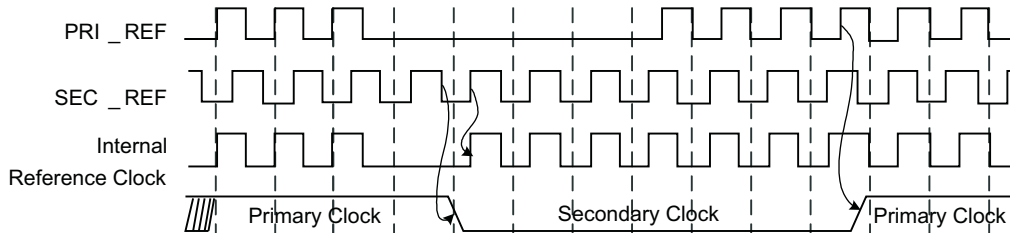

Figure 20. CDCE62005 Smart Multiplexer Timing Diagram

8.3.5.5 Smart Multiplexer Dividers

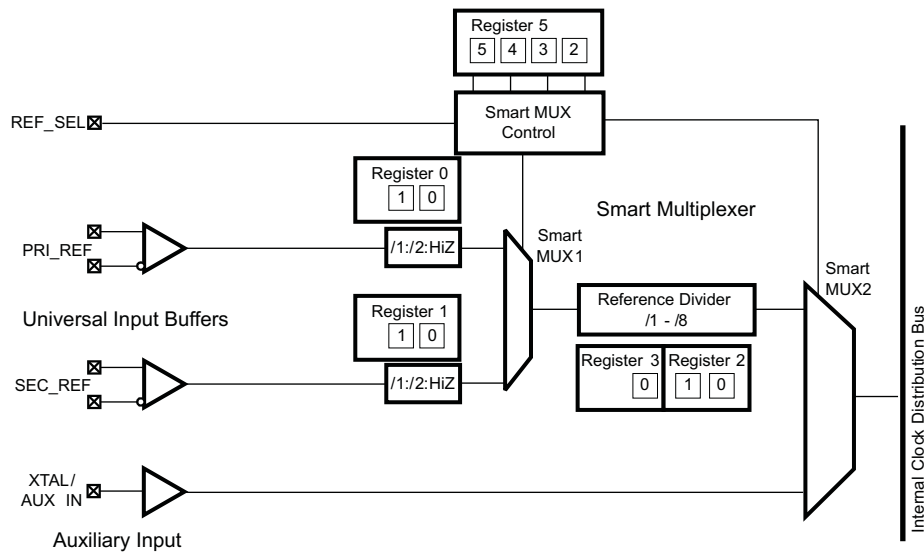

Figure 21. CDCE62005 Smart Multiplexer

The CDCE62005 Smart Multiplexer Block provides the ability to divide the primary and secondary UIB or to disconnect a UIB from the first state of the smart multiplexer altogether.

Table 8. CDCE62005 Pre-Divider Settings

BIT NAME → REGISTER.BIT →	PRIMARY PRE-DIVIDER			BIT NAME → REGISTER.BIT →	SECONDARY PRE-DIVIDER		DIVIDE RATIO
	DIV2PRIY 0.1	DIV2PRIX 0.0	DIVIDE RATIO		DIV2SECY 1.1	DIV2SECX 1.0	
	0	0	Hi-Z		0	0	Hi-Z
	0	1	/2		0	1	/2
	1	0	/1		1	0	/1
	1	1	Reserved		1	1	Reserved

The CDCE62005 provides a Reference Divider that divides the clock exiting the first multiplexer stage; thus dividing the primary (PRI_REF) or the secondary input (SEC_REF).

Table 9. CDCE62005 Reference Divider Settings

BIT NAME → REGISTER.BIT →	REFERENCE DIVIDER			DIVIDE RATIO
	REFDIV2 3.0	REFDIV1 2.1	REFDIV0 2.0	
	0	0	0	/1
	0	0	1	/2
	0	1	0	/3
	0	1	1	/4
	1	0	0	/5
	1	0	1	/6
	1	1	0	/7
	1	1	1	/8

8.3.5.6 Output Block

The output block includes five identical output channels. Each output channel comprises an output multiplexer, a clock divider module, and a universal output buffer as shown in Figure 22.

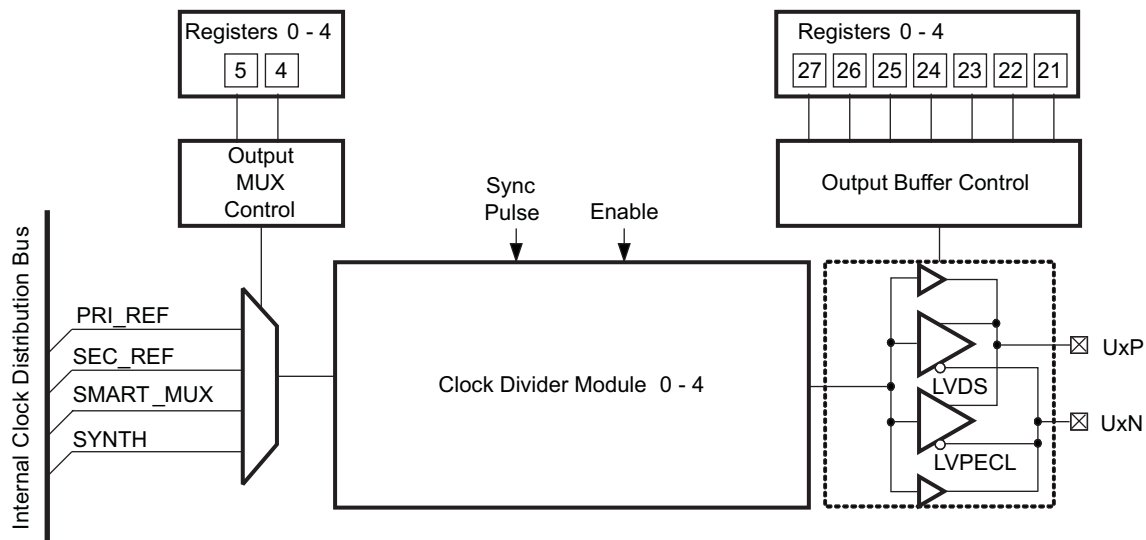

Figure 22. CDCE62005 Output Channel

8.3.5.7 Output Multiplexer Control

The Clock Divider Module receives the clock selected by the output multiplexer. The output multiplexer selects from one of four clock sources available on the Internal Clock Distribution. For a description of PRI_REF, SEC_REF, and SMART_MUX, see [Figure 18](#). For a description of SYNTH, see [Figure 28](#).

Table 10. CDCE62005 Output Multiplexer Control Settings

OUTPUT MULTIPLEXER CONTROL		CLOCK SOURCE SELECTED
REGISTER n (n = 0,1,2,3,4)		
OUTMUXnSELX n.4	OUTMUXnSELY n.5	
0	0	PRI_REF
0	1	SEC_REF
1	0	SMART_MUX
1	1	SYNTH

8.3.5.8 Output Buffer Control

Each of the five output channels includes a programmable output buffer; supporting LVPECL, LVDS, and LVCMOS modes. [Table 11](#) lists the settings required to configure the CDCE62005 for each output type. Registers 0 through 4 correspond to Output Channels 0 through 4 respectively.

Table 11. CDCE62005 Output Buffer Control Settings

OUTPUT BUFFER CONTROL						OUTPUT TYPE
REGISTER n (n = 0,1,2,3,4)						
CMOSMODEnPX n.22	CMOSMODEnPY n.23	CMOSMODEnNX n.24	CMOSMODEnNY n.25	OUTBUFSELnX n.26	OUTBUFSELnY n.27	
0	0	0	0	0	1	LVPECL
0	1	0	1	1	1	LVDS
See LVCMOS Output Buffer Configuration Settings				0	0	LVCMOS
0	1	0	1	1	0	Disabled to High-Z

8.3.5.9 Output Buffer Control – LVCMOS Configurations

A LVCMOS output configuration requires additional configuration data. In the single ended configuration, each Output Channel provides a pair of outputs. The CDCE62005 supports four modes of operation for single ended outputs as listed in [Table 12](#).

Table 12. LVCMOS Output Buffer Configuration Settings

OUTPUT BUFFER CONTROL – LVCMOS CONFIGURATION						OUTPUT TYPE	PIN	OUTPUT MODE
REGISTER n (n = 0,1,2,3,4)								
CMOSMODEnPX n.22	CMOSMODEnPY n.23	CMOSMODEnNX n.24	CMOSMODEnNY n.25	OUTBUFSELnX n.26	OUTBUFSELnY n.27			
X	X	0	0	0	0	LVCMOS	Negative	Active – Non-inverted
X	X	0	1	0	0	LVCMOS	Negative	Hi-Z
X	X	1	0	0	0	LVCMOS	Negative	Active – Non-inverted
X	X	1	1	0	0	LVCMOS	Negative	Low
0	0	X	X	0	0	LVCMOS	Positive	Active – Non-inverted
0	1	X	X	0	0	LVCMOS	Positive	Hi-Z
1	0	X	X	0	0	LVCMOS	Positive	Active – Non-inverted
1	1	X	X	0	0	LVCMOS	Positive	Low

8.3.5.10 Output Dividers

Figure 23 shows that each output channel provides a 7-bit divider and digital phase adjust block. The Table 13 lists the divide ratios supported by the output divider for each output channel. Figure 24 illustrates the output divider architecture in detail. The Prescaler provides an array of low noise dividers with duty cycle correction. The Integer Divider includes a final divide by two stage which is used to correct the duty cycle of the /1–/8 stage. The output divider’s maximum input frequency is limited to 1.175 GHz. If the divider is bypassed (divide ratio = 1) then the maximum frequency of the output channel is 1.5 GHz.

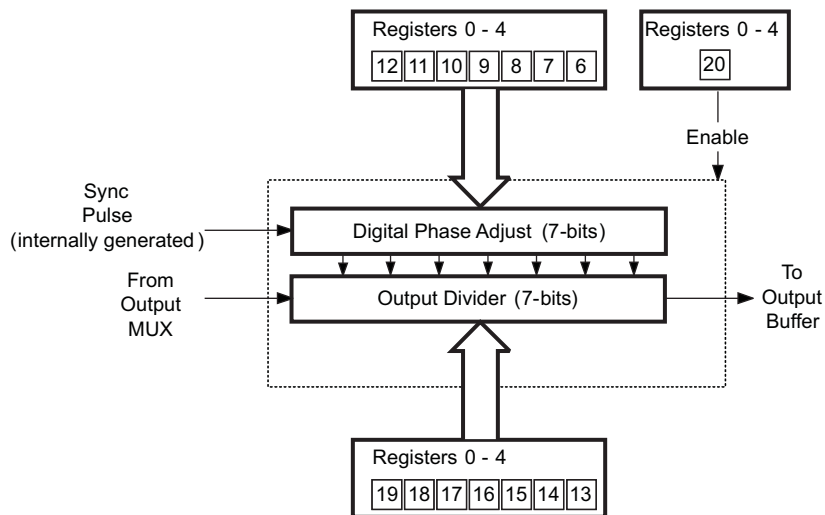

Figure 23. CDCE62005 Output Divider and Phase Adjust

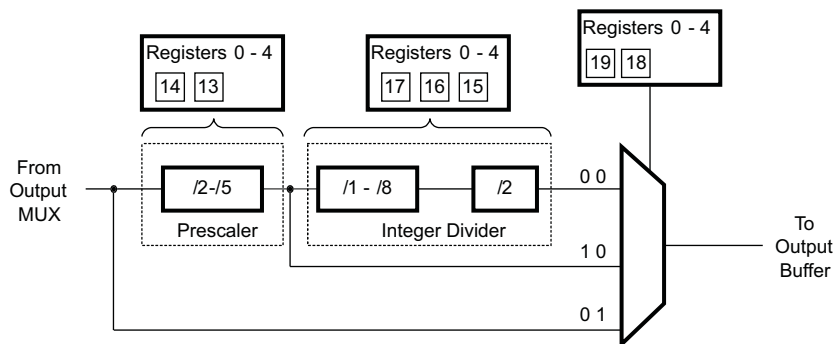

Figure 24. CDCE62005 Output Divider Architecture

Table 13. CDCE62005 Output Divider Settings⁽¹⁾

OUTPUT DIVIDER n SETTINGS REGISTER (n = 0,1,2,3,4)								PRESCALER SETTING	INTEGER DIVIDER SETTING	OUTPUT DIVIDE RATIO	
MULTIPLEXER		INTEGER DIVIDER			PRESCALER					OUTPUT CHANNELS 0-4	AUXILIARY OUTPUT
OUTn-DIVSEL6	OUTn-DIVSEL5	OUTn-DIVSEL4	OUTn-DIVSEL3	OUTn-DIVSEL2	OUTn-DIVSEL1	OUTn-DIVSEL0	OUTn-DIVSEL				
n.19	n.18	n.17	n.16	n.15	n.14	n.13	n.20				
X	X	X	X	X	X	X	0			OFF	OFF
0	1	0	0	0	0	0	1	–	–	1	OFF
1	0	0	0	0	0	0	1	2	–	2*	4
1	0	0	0	0	0	1	1	3	–	3*	6
1	0	0	0	0	1	0	1	4	–	4	8
1	0	0	0	0	1	1	1	5	–	5	10
0	0	0	0	0	0	1	1	3	2	6	6
0	0	0	0	0	1	0	1	4	2	8	8
0	0	0	0	0	1	1	1	5	2	10	10
0	0	0	0	1	0	1	1	3	4	12	12
0	0	0	0	1	1	0	1	4	4	16	16
0	0	0	0	1	1	1	1	5	4	20	20
0	0	0	1	0	0	1	1	3	6	18	18
0	0	0	1	0	1	0	1	4	6	24	24
0	0	0	1	0	1	1	1	5	6	30	30
0	0	0	1	1	1	0	1	4	8	32	32
0	0	0	1	1	1	1	1	5	8	40	40
0	0	1	0	0	1	1	1	5	10	50	50
0	0	1	0	1	0	1	1	3	12	36	36
0	0	1	0	1	1	0	1	4	12	48	48
0	0	1	0	1	1	1	1	5	12	60	60
0	0	1	1	0	0	0	1	2	14	28	28
0	0	1	1	0	0	1	1	3	14	42	42
0	0	1	1	0	1	0	1	4	14	56	56
0	0	1	1	0	1	1	1	5	14	70	70
0	0	1	1	1	1	0	1	4	16	64	64
0	0	1	1	1	1	1	1	5	16	80	80

(1) Output channel 2 or 3 determine the auxiliary output divide ratio. For example, if the auxiliary output is programmed to drive via output 2 and output 2 divider is programmed to divide by 3, then the divide ratio for the auxiliary output will be 6.

8.3.5.11 Digital Phase Adjust

Figure 25 provides an overview of the Digital Phase Adjust feature. The output divider includes a coarse phase adjust that shifts the divided clock signal that drives the output buffer. Essentially, the Digital Phase Adjust timer delays when the output divider starts dividing; thereby shifting the phase of the output clock. The phase adjust resolution is a function of the divide function. Coarse phase adjust parameters include:

Number of phase delay steps the number of phase delay steps available is equal to the divide ratio selected.

For example, if a Divide by 4 is selected, then the Digital Phase Adjust can be programmed to select when the output divider changes state based upon selecting one of the four counts on the input. Figure 25 shows an example of divide by 16 in which there are 16 rising edges of Clock IN at which the output divider changes state (this particular example shows the fourth edge shifting the output by one fourth of the period of the output).

Phase delay step size the step size is determined by the number of phase delay steps according to the following equations:

$$\text{Stepsize(deg)} = \frac{360 \text{ degrees}}{\text{OutputDivideRatio}} \quad (5)$$

$$\text{Stepsize(sec)} = \frac{1}{\text{OutputDivideRatio} \cdot f_{\text{ClockIN}}} \quad (6)$$

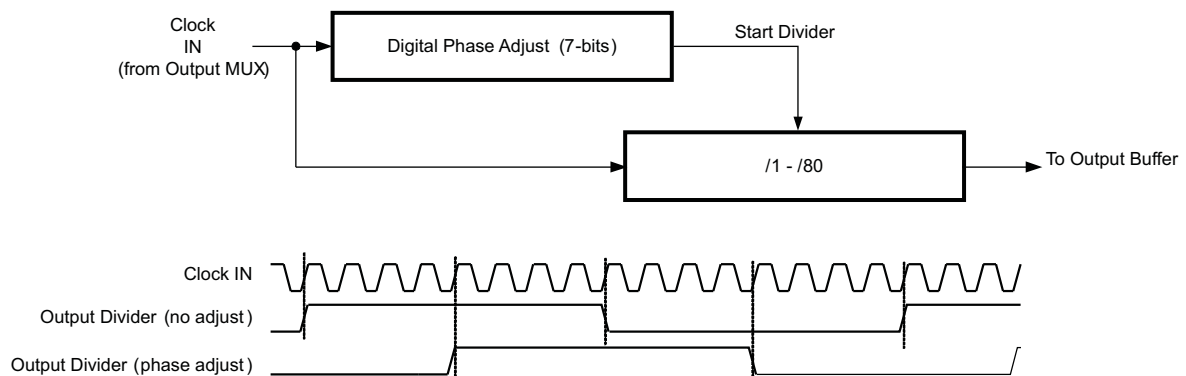

Figure 25. CDCE62005 Phase Adjust

8.3.5.12 Phase Adjust Example

Given:

- Output Frequency = 30.72 MHz
- VCO Operating Frequency = 1966.08 MHz
- Prescaler Divider Setting = 4
- Output Divider Setting = 16

$$\text{Stepsize(deg)} = \frac{360}{16} = 22.5^\circ/\text{Step} \quad (7)$$

8.3.5.13 Valid Register Settings for Digital Phase Adjust Blocks

Table 14 through Table 19 provide a list of valid register settings for the digital phase adjust blocks.

Table 14. CDCE62005 Output Coarse Phase Adjust Settings (1)

Divide Ratio	PHnADGC6	PHnADGC5	PHnADGC4	PHnADGC3	PHnADGC2	PHnADGC1	PHnADGC0	Phase Delay (radian)
	n.12	n.11	n.10	n.9	n.8	n.7	n.6	
1	0	0	0	0	0	0	0	0
2	0	0	0	0	0	0	0	0
	0	0	0	0	0	0	1	(2π/2)
3	0	0	0	0	0	0	0	0
	0	0	0	0	0	0	1	(2π/3)
	0	0	0	0	0	1	0	2(2π/3)
4	0	0	0	0	0	0	0	0
	0	0	0	0	0	0	1	(2π/4)
	0	0	0	0	0	1	0	2(2π/4)
	0	0	0	0	0	1	1	3(2π/4)
5	0	0	0	0	0	0	0	0
	0	0	0	0	0	0	1	(2π/5)
	0	0	0	0	0	1	0	2(2π/5)
	0	0	0	0	0	1	1	3(2π/5)
	0	0	0	0	1	0	0	4(2π/5)
6	0	0	0	0	0	0	0	0
	0	0	0	0	0	0	1	(2π/6)
	0	0	0	0	0	1	0	2(2π/6)
	1	0	0	0	0	0	0	3(2π/6)
	1	0	0	0	0	0	1	4(2π/6)
	1	0	0	0	0	1	0	5(2π/6)
8	0	0	0	0	0	0	0	0
	0	0	0	0	0	0	1	(2π/8)
	0	0	0	0	0	1	0	2(2π/8)
	0	0	0	0	0	1	1	3(2π/8)
	1	0	0	0	0	0	0	4(2π/8)
	1	0	0	0	0	0	1	5(2π/8)
	1	0	0	0	0	1	0	6(2π/8)
	1	0	0	0	0	1	1	7(2π/8)
10	0	0	0	0	0	0	0	0
	0	0	0	0	0	0	1	(2π/10)
	0	0	0	0	0	1	0	2(2π/10)
	0	0	0	0	0	1	1	3(2π/10)
	0	0	0	0	1	0	0	4(2π/10)
	1	0	0	0	0	0	0	5(2π/10)
	1	0	0	0	0	0	1	6(2π/10)
	1	0	0	0	0	1	0	7(2π/10)
	1	0	0	0	0	1	1	8(2π/10)
	1	0	0	0	1	0	0	9(2π/10)
12	0	0	0	0	0	0	0	0
	0	0	0	0	0	0	1	(2π/12)
	0	0	0	0	0	1	0	2(2π/12)
	0	0	0	1	0	0	0	3(2π/12)
	0	0	0	1	0	0	1	4(2π/12)
	0	0	0	1	0	1	0	5(2π/12)
	0	0	1	0	0	0	0	6(2π/12)
	0	0	1	0	0	0	1	7(2π/12)
	0	0	1	0	0	1	0	8(2π/12)
	0	0	1	1	0	0	0	9(2π/12)
	0	0	1	1	0	0	1	10(2π/12)
	0	0	1	1	0	1	0	11(2π/12)
16	0	0	0	0	0	0	0	0
	0	0	0	0	0	0	1	(2π/16)
	0	0	0	0	0	1	0	2(2π/16)
	0	0	0	0	0	1	1	3(2π/16)
	0	0	0	1	0	0	0	4(2π/16)
	0	0	0	1	0	0	1	5(2π/16)
	0	0	0	1	0	1	0	6(2π/16)
	0	0	0	1	0	1	1	7(2π/16)
	0	0	1	0	0	0	0	8(2π/16)
	0	0	1	0	0	0	1	9(2π/16)
	0	0	1	0	0	1	0	10(2π/16)
	0	0	1	0	0	1	1	11(2π/16)
	0	0	1	1	0	0	0	12(2π/16)
	0	0	1	1	0	0	1	13(2π/16)
	0	0	1	1	0	1	0	14(2π/16)
	0	0	1	1	0	1	1	15(2π/16)

Divide Ratio	PHnADGC6	PHnADGC5	PHnADGC4	PHnADGC3	PHnADGC2	PHnADGC1	PHnADGC0	Phase Delay (radian)
	n.12	n.11	n.10	n.9	n.8	n.7	n.6	
18	0	0	0	0	0	0	0	0
	0	0	0	0	0	0	1	(2π/18)
	0	0	0	0	0	1	0	2(2π/18)
	0	0	0	1	0	0	0	3(2π/18)
	0	0	0	1	0	0	1	4(2π/18)
	0	0	0	1	0	1	0	5(2π/18)
	0	0	1	0	0	0	0	6(2π/18)
	0	0	1	0	0	0	1	7(2π/18)
	0	0	1	0	0	1	0	8(2π/18)
	0	0	1	1	0	0	0	9(2π/18)
	0	0	1	1	0	0	1	10(2π/18)
	0	0	1	1	0	1	0	11(2π/18)
	0	1	0	0	0	0	0	12(2π/18)
	0	1	0	0	0	0	1	13(2π/18)
	0	1	0	1	0	0	0	14(2π/18)
	0	1	0	1	0	0	1	15(2π/18)
	0	1	0	1	0	0	1	16(2π/18)
	0	1	0	1	0	1	0	17(2π/18)
20	0	0	0	0	0	0	0	0
	0	0	0	0	0	0	1	(2π/20)
	0	0	0	0	0	1	0	2(2π/20)
	0	0	0	0	0	1	1	3(2π/20)
	0	0	0	0	1	0	0	4(2π/20)
	0	0	0	1	0	0	0	5(2π/20)
	0	0	0	1	0	0	1	6(2π/20)
	0	0	0	1	0	1	0	7(2π/20)
	0	0	0	1	0	1	1	8(2π/20)
	0	0	0	1	1	0	0	9(2π/20)
	0	0	1	0	0	0	0	10(2π/20)
	0	0	1	0	0	0	1	11(2π/20)
	0	0	1	0	0	1	0	12(2π/20)
	0	0	1	0	0	1	1	13(2π/20)
	0	0	1	0	1	0	0	14(2π/20)
	0	0	1	1	0	0	0	15(2π/20)
	0	0	1	1	0	0	1	16(2π/20)
	0	0	1	1	0	1	0	17(2π/20)
	0	0	1	1	0	1	1	18(2π/20)
	0	0	1	1	1	0	0	19(2π/20)
24	0	0	0	0	0	0	0	0
	0	0	0	0	0	0	1	(2π/24)
	0	0	0	0	0	1	0	2(2π/24)
	0	0	0	0	0	1	1	3(2π/24)
	0	0	0	1	0	0	0	4(2π/24)
	0	0	0	1	0	0	1	5(2π/24)
	0	0	0	1	0	1	0	6(2π/24)
	0	0	0	1	0	1	1	7(2π/24)
	0	0	1	0	0	0	0	8(2π/24)
	0	0	1	0	0	0	1	9(2π/24)
	0	0	1	0	0	1	0	10(2π/24)
	0	0	1	0	0	1	1	11(2π/24)
	0	0	1	1	0	0	0	12(2π/24)
	0	0	1	1	0	0	1	13(2π/24)
	0	0	1	1	0	1	0	14(2π/24)
	0	0	1	1	0	1	1	15(2π/24)
	0	1	0	0	0	0	0	16(2π/24)
	0	1	0	0	0	0	1	17(2π/24)
	0	1	0	0	0	1	0	18(2π/24)
	0	1	0	0	0	1	1	19(2π/24)
	0	1	0	1	0	0	0	20(2π/24)
	0	1	0	1	0	0	1	21(2π/24)
	0	1	0	1	0	1	0	22(2π/24)
	0	1	0	1	0	1	1	23(2π/24)

Table 15. CDCE62005 Output Coarse Phase Adjust Settings (2)

Divide Ratio	PHnADGC6	PHnADGC5	PHnADGC4	PHnADGC3	PHnADGC2	PHnADGC1	PHnADGC0	Phase Delay
	n.12	n.11	n.10	n.9	n.8	n.7	n.6	(radian)
28	0	0	0	0	0	0	0	0
	0	0	0	0	0	0	1	(2π/28)
	0	0	0	1	0	0	0	2(2π/28)
	0	0	0	1	0	0	1	3(2π/28)
	0	0	1	0	0	0	0	4(2π/28)
	0	0	1	0	0	0	1	5(2π/28)
	0	0	1	1	0	0	0	6(2π/28)
	0	0	1	1	0	0	1	7(2π/28)
	0	1	0	0	0	0	0	8(2π/28)
	0	1	0	0	0	0	1	9(2π/28)
	0	1	0	1	0	0	0	10(2π/28)
	0	1	0	1	0	0	1	11(2π/28)
	0	1	1	0	0	0	0	12(2π/28)
	0	1	1	0	0	0	1	13(2π/28)
	1	0	0	0	0	0	0	14(2π/28)
	1	0	0	0	0	0	1	15(2π/28)
	1	0	0	1	0	0	0	16(2π/28)
	1	0	0	1	0	0	1	17(2π/28)
	1	0	1	0	0	0	0	18(2π/28)
	1	0	1	0	0	0	1	19(2π/28)
	1	0	1	1	0	0	0	20(2π/28)
	1	0	1	1	0	0	1	21(2π/28)
	1	1	0	0	0	0	0	22(2π/28)
	1	1	0	0	0	0	1	23(2π/28)
	1	1	0	1	0	0	0	24(2π/28)
	1	1	0	1	0	0	1	25(2π/28)
	1	1	1	0	0	0	0	26(2π/28)
	1	1	1	0	0	0	1	27(2π/28)
30	0	0	0	0	0	0	0	0
	0	0	0	0	0	0	1	(2π/30)
	0	0	0	0	0	1	0	2(2π/30)
	0	0	0	0	0	1	1	3(2π/30)
	0	0	0	0	1	0	0	4(2π/30)
	0	0	0	1	0	0	0	5(2π/30)
	0	0	0	1	0	0	1	6(2π/30)
	0	0	0	1	0	1	0	7(2π/30)
	0	0	0	1	0	1	1	8(2π/30)
	0	0	0	1	1	0	0	9(2π/30)
	0	0	1	0	0	0	0	10(2π/30)
	0	0	1	0	0	0	1	11(2π/30)
	0	0	1	0	0	1	0	12(2π/30)
	0	0	1	0	0	1	1	13(2π/30)
	0	0	1	1	0	0	0	14(2π/30)
	0	0	1	1	0	0	1	15(2π/30)
	0	0	1	1	0	0	1	16(2π/30)
	0	0	1	1	0	1	0	17(2π/30)
	0	0	1	1	0	1	1	18(2π/30)
	0	0	1	1	1	0	0	19(2π/30)
	0	1	0	0	0	0	0	20(2π/30)
	0	1	0	0	0	0	1	21(2π/30)
	0	1	0	0	0	1	0	22(2π/30)
	0	1	0	0	0	1	1	23(2π/30)
	0	1	0	0	1	0	0	24(2π/30)
	0	1	0	1	0	0	0	25(2π/30)
	0	1	0	1	0	0	1	26(2π/30)
	0	1	0	1	0	1	1	27(2π/30)
	0	1	0	1	1	0	0	28(2π/30)
	0	1	0	1	1	0	0	29(2π/30)

Divide Ratio	PHnADGC6	PHnADGC5	PHnADGC4	PHnADGC3	PHnADGC2	PHnADGC1	PHnADGC0	Phase Delay
	n.12	n.11	n.10	n.9	n.8	n.7	n.6	(radian)
32	0	0	0	0	0	0	0	0
	0	0	0	0	0	0	1	(2π/32)
	0	0	0	0	0	1	0	2(2π/32)
	0	0	0	0	0	1	1	3(2π/32)
	0	0	0	1	0	0	0	4(2π/32)
	0	0	0	1	0	0	1	5(2π/32)
	0	0	0	1	0	1	0	6(2π/32)
	0	0	0	1	0	1	1	7(2π/32)
	0	0	1	0	0	0	0	8(2π/32)
	0	0	1	0	0	0	1	9(2π/32)
	0	0	1	0	0	1	0	10(2π/32)
	0	0	1	0	0	1	1	11(2π/32)
	0	0	1	1	0	0	0	12(2π/32)
	0	0	1	1	0	0	1	13(2π/32)
	0	0	1	1	0	1	0	14(2π/32)
	0	0	1	1	0	1	1	15(2π/32)
	0	1	0	0	0	0	0	16(2π/32)
	0	1	0	0	0	0	1	17(2π/32)
	0	1	0	0	0	1	0	18(2π/32)
	0	1	0	0	0	1	1	19(2π/32)
	0	1	0	1	0	0	0	20(2π/32)
	0	1	0	1	0	0	1	21(2π/32)
	0	1	0	1	0	1	0	22(2π/32)
	0	1	0	1	0	1	1	23(2π/32)
	0	1	1	0	0	0	0	24(2π/32)
	0	1	1	0	0	0	1	25(2π/32)
	0	1	1	0	0	1	0	26(2π/32)
	0	1	1	0	0	1	1	27(2π/32)
	0	1	1	1	0	0	0	28(2π/32)
	0	1	1	1	0	0	1	29(2π/32)
	0	1	1	1	0	1	0	30(2π/32)
	0	1	1	1	0	1	1	31(2π/32)
36	0	0	0	0	0	0	0	0
	0	0	0	0	0	0	1	(2π/36)
	0	0	0	0	0	1	0	2(2π/36)
	0	0	0	1	0	0	0	3(2π/36)
	0	0	0	1	0	0	1	4(2π/36)
	0	0	0	1	0	1	0	5(2π/36)
	0	0	1	0	0	0	0	6(2π/36)
	0	0	1	0	0	0	1	7(2π/36)
	0	0	1	0	0	1	0	8(2π/36)
	0	0	1	1	0	0	0	9(2π/36)
	0	0	1	1	0	0	1	10(2π/36)
	0	0	1	1	0	1	0	11(2π/36)
	0	1	0	0	0	0	0	12(2π/36)
	0	1	0	0	0	0	1	13(2π/36)
	0	1	0	0	0	1	0	14(2π/36)
	0	1	0	1	0	0	0	15(2π/36)
	0	1	0	1	0	0	1	16(2π/36)
	0	1	0	1	0	1	0	17(2π/36)
	1	0	0	0	0	0	0	18(2π/36)
	1	0	0	0	0	0	1	19(2π/36)
	1	0	0	0	0	1	0	20(2π/36)
	1	0	0	1	0	0	0	21(2π/36)
	1	0	0	1	0	0	1	22(2π/36)
	1	0	0	1	0	1	0	23(2π/36)
	1	0	1	0	0	0	0	24(2π/36)
	1	0	1	0	0	0	1	25(2π/36)
	1	0	1	0	0	1	0	26(2π/36)
	1	0	1	1	0	0	0	27(2π/36)
	1	0	1	1	0	0	1	28(2π/36)
	1	0	1	1	0	1	0	29(2π/36)
	1	1	0	0	0	0	0	30(2π/36)
	1	1	0	0	0	0	1	31(2π/36)
	1	1	0	0	0	1	0	32(2π/36)
	1	1	0	1	0	0	0	33(2π/36)
	1	1	0	1	0	0	1	34(2π/36)
	1	1	0	1	0	1	0	35(2π/36)

Table 16. CDCE62005 Output Coarse Phase Adjust Settings (3)

Divide Ratio	PHnADGC6	PHnADGC5	PHnADGC4	PHnADGC3	PHnADGC2	PHnADGC1	PHnADGC0	Phase Delay (radian)
	n.12	n.11	n.10	n.9	n.8	n.7	n.6	
40	0	0	0	0	0	0	0	0
	0	0	0	0	0	0	1	(2π/40)
	0	0	0	0	0	1	0	2(2π/40)
	0	0	0	0	0	1	1	3(2π/40)
	0	0	0	0	1	0	0	4(2π/40)
	0	0	0	1	0	0	0	5(2π/40)
	0	0	0	1	0	0	1	6(2π/40)
	0	0	0	1	0	1	0	7(2π/40)
	0	0	0	1	0	1	1	8(2π/40)
	0	0	0	1	1	0	0	9(2π/40)
	0	0	1	0	0	0	0	10(2π/40)
	0	0	1	0	0	0	1	11(2π/40)
	0	0	1	0	0	1	0	12(2π/40)
	0	0	1	0	0	1	1	13(2π/40)
	0	0	1	0	1	0	0	14(2π/40)
	0	0	1	1	0	0	0	15(2π/40)
	0	0	1	1	0	0	1	16(2π/40)
	0	0	1	1	0	1	0	17(2π/40)
	0	0	1	1	0	1	1	18(2π/40)
	0	0	1	1	1	0	0	19(2π/40)
	0	1	0	0	0	0	0	20(2π/40)
	0	1	0	0	0	0	1	21(2π/40)
	0	1	0	0	0	1	0	22(2π/40)
	0	1	0	0	0	1	1	23(2π/40)
	0	1	0	0	1	0	0	24(2π/40)
	0	1	0	1	0	0	0	25(2π/40)
	0	1	0	1	0	0	1	26(2π/40)
	0	1	0	1	0	1	0	27(2π/40)
	0	1	0	1	0	1	1	28(2π/40)
	0	1	0	1	1	0	0	29(2π/40)
	0	1	1	0	0	0	0	30(2π/40)
	0	1	1	0	0	0	1	31(2π/40)
	0	1	1	0	0	1	0	32(2π/40)
	0	1	1	0	0	1	1	33(2π/40)
	0	1	1	0	1	0	0	34(2π/40)
	0	1	1	1	0	0	0	35(2π/40)
	0	1	1	1	0	0	1	36(2π/40)
	0	1	1	1	0	1	0	37(2π/40)
	0	1	1	1	0	1	1	38(2π/40)
0	1	1	1	1	0	0	39(2π/40)	
42	0	0	0	0	0	0	0	0
	0	0	0	0	0	0	1	(2π/42)
	0	0	0	0	0	1	0	2(2π/42)
	0	0	0	1	0	0	0	3(2π/42)
	0	0	0	1	0	0	1	4(2π/42)
	0	0	0	1	0	1	0	5(2π/42)
	0	0	1	0	0	0	0	6(2π/42)
	0	0	1	0	0	0	1	7(2π/42)
	0	0	1	0	0	1	0	8(2π/42)
	0	0	1	1	0	0	0	9(2π/42)
	0	0	1	1	0	0	1	10(2π/42)
	0	0	1	1	0	1	0	11(2π/42)
	0	1	0	0	0	0	0	12(2π/42)
	0	1	0	0	0	0	1	13(2π/42)
	0	1	0	0	0	1	0	14(2π/42)
	0	1	0	1	0	0	0	15(2π/42)
	0	1	0	1	0	0	1	16(2π/42)
	0	1	0	1	0	1	0	17(2π/42)
	0	1	1	0	0	0	0	18(2π/42)
	0	1	1	0	0	0	1	19(2π/42)
	0	1	1	0	0	1	0	20(2π/42)
	1	0	0	0	0	0	0	21(2π/42)
	1	0	0	0	0	0	1	22(2π/42)
	1	0	0	0	0	1	0	23(2π/42)
	1	0	0	1	0	0	0	24(2π/42)
	1	0	0	1	0	0	1	25(2π/42)
	1	0	0	1	0	1	0	26(2π/42)
	1	0	1	0	0	0	0	27(2π/42)
	1	0	1	0	0	0	1	28(2π/42)
	1	0	1	0	0	1	0	29(2π/42)
	1	0	1	1	0	0	0	30(2π/42)
	1	0	1	1	0	0	1	31(2π/42)
	1	0	1	1	0	1	0	32(2π/42)
	1	1	0	0	0	0	0	33(2π/42)
	1	1	0	0	0	0	1	34(2π/42)
	1	1	0	0	0	1	0	35(2π/42)
	1	1	0	1	0	0	0	36(2π/42)
	1	1	0	1	0	0	1	37(2π/42)
	1	1	0	1	0	1	0	38(2π/42)
1	1	1	0	0	0	0	39(2π/42)	
1	1	1	0	0	0	1	40(2π/42)	
1	1	1	0	0	1	0	41(2π/42)	

Divide Ratio	PHnADGC6	PHnADGC5	PHnADGC4	PHnADGC3	PHnADGC2	PHnADGC1	PHnADGC0	Phase Delay (radian)
	n.12	n.11	n.10	n.9	n.8	n.7	n.6	
48	0	0	0	0	0	0	0	0
	0	0	0	0	0	0	1	(2π/48)
	0	0	0	0	0	1	0	2(2π/48)
	0	0	0	0	0	1	1	3(2π/48)
	0	0	0	1	0	0	0	4(2π/48)
	0	0	0	1	0	0	1	5(2π/48)
	0	0	0	1	0	1	0	6(2π/48)
	0	0	0	1	0	1	1	7(2π/48)
	0	0	1	0	0	0	0	8(2π/48)
	0	0	1	0	0	0	1	9(2π/48)
	0	0	1	0	0	1	0	10(2π/48)
	0	0	1	0	0	1	1	11(2π/48)
	0	0	1	1	0	0	0	12(2π/48)
	0	0	1	1	0	0	1	13(2π/48)
	0	0	1	1	1	0	0	14(2π/48)
	0	0	1	1	1	0	1	15(2π/48)
	0	1	0	0	0	0	0	16(2π/48)
	0	1	0	0	0	0	1	17(2π/48)
	0	1	0	0	0	1	0	18(2π/48)
	0	1	0	0	0	1	1	19(2π/48)
	0	1	0	1	0	0	0	20(2π/48)
	0	1	0	1	0	0	1	21(2π/48)
	0	1	0	1	0	1	0	22(2π/48)
	0	1	0	1	0	1	1	23(2π/48)
	1	0	0	0	0	0	0	24(2π/48)
	1	0	0	0	0	0	1	25(2π/48)
	1	0	0	0	0	1	0	26(2π/48)
	1	0	0	0	0	1	1	27(2π/48)
	1	0	0	1	0	0	0	28(2π/48)
	1	0	0	1	0	0	1	29(2π/48)
	1	0	0	1	0	1	0	30(2π/48)
	1	0	0	1	0	1	1	31(2π/48)
	1	0	1	0	0	0	0	32(2π/48)
	1	0	1	0	0	0	1	33(2π/48)
	1	0	1	0	0	1	0	34(2π/48)
	1	0	1	0	0	1	1	35(2π/48)
	1	0	1	1	0	0	0	36(2π/48)
	1	0	1	1	0	0	1	37(2π/48)
	1	0	1	1	0	1	0	38(2π/48)
	1	0	1	1	0	1	1	39(2π/48)
	1	1	0	0	0	0	0	40(2π/48)
	1	1	0	0	0	0	1	41(2π/48)
	1	1	0	0	0	1	0	42(2π/48)
	1	1	0	0	0	1	1	43(2π/48)
	1	1	0	1	0	0	0	44(2π/48)
	1	1	0	1	0	0	1	45(2π/48)
	1	1	0	1	0	1	0	46(2π/48)
1	1	0	1	0	1	1	47(2π/48)	

Table 17. CDCE62005 Output Coarse Phase Adjust Settings (4)

Divide Ratio	PHnADGG6	PHnADGG5	PHnADGG4	PHnADGG3	PHnADGG2	PHnADGG1	PHnADGG0	Phase Delay (radian)
	n.12	n.11	n.10	n.9	n.8	n.7	n.6	
50	0	0	0	0	0	0	0	0
	0	0	0	0	0	0	1	(2π/50)
	0	0	0	0	0	1	0	2(2π/50)
	0	0	0	0	0	1	1	3(2π/50)
	0	0	0	0	1	0	0	4(2π/50)
	0	0	0	1	0	0	0	5(2π/50)
	0	0	0	1	0	0	1	6(2π/50)
	0	0	0	1	0	1	0	7(2π/50)
	0	0	0	1	0	1	1	8(2π/50)
	0	0	0	1	1	0	0	9(2π/50)
	0	0	1	0	0	0	0	10(2π/50)
	0	0	1	0	0	0	1	11(2π/50)
	0	0	1	0	0	1	0	12(2π/50)
	0	0	1	0	0	1	1	13(2π/50)
	0	0	1	0	1	0	0	14(2π/50)
	0	0	1	1	0	0	0	15(2π/50)
	0	0	1	1	0	0	1	16(2π/50)
	0	0	1	1	0	1	0	17(2π/50)
	0	0	1	1	0	1	1	18(2π/50)
	0	0	1	1	1	0	0	19(2π/50)
	0	1	0	0	0	0	0	20(2π/50)
	0	1	0	0	0	0	1	21(2π/50)
	0	1	0	0	0	1	0	22(2π/50)
	0	1	0	0	0	1	1	23(2π/50)
	0	1	0	0	1	0	0	24(2π/50)
	1	0	0	0	0	0	0	25(2π/50)
	1	0	0	0	0	0	1	26(2π/50)
	1	0	0	0	0	1	0	27(2π/50)
	1	0	0	0	0	1	1	28(2π/50)
	1	0	0	0	1	0	0	29(2π/50)
	1	0	0	1	0	0	0	30(2π/50)
	1	0	0	1	0	0	1	31(2π/50)
	1	0	0	1	0	1	0	32(2π/50)
	1	0	0	1	0	1	1	33(2π/50)
	1	0	0	1	1	0	0	34(2π/50)
	1	0	1	0	0	0	0	35(2π/50)
	1	0	1	0	0	0	1	36(2π/50)
	1	0	1	0	0	1	0	37(2π/50)
	1	0	1	0	0	1	1	38(2π/50)
	1	0	1	0	1	0	0	39(2π/50)
	1	0	1	1	0	0	0	40(2π/50)
	1	0	1	1	0	0	1	41(2π/50)
	1	0	1	1	0	1	0	42(2π/50)
	1	0	1	1	0	1	1	43(2π/50)
	1	0	1	1	1	0	0	44(2π/50)
	1	1	0	0	0	0	0	45(2π/50)
	1	1	0	0	0	0	1	46(2π/50)
	1	1	0	0	0	1	0	47(2π/50)
	1	1	0	0	0	1	1	48(2π/50)
	1	1	0	0	1	0	0	49(2π/50)

Divide Ratio	PHnADGG6	PHnADGG5	PHnADGG4	PHnADGG3	PHnADGG2	PHnADGG1	PHnADGG0	Phase Delay (radian)
	n.12	n.11	n.10	n.9	n.8	n.7	n.6	
56	0	0	0	0	0	0	0	0
	0	0	0	0	0	0	1	(2π/56)
	0	0	0	0	0	1	0	2(2π/56)
	0	0	0	0	0	1	1	3(2π/56)
	0	0	0	1	0	0	0	4(2π/56)
	0	0	0	1	0	0	1	5(2π/56)
	0	0	0	1	0	1	0	6(2π/56)
	0	0	0	1	0	1	1	7(2π/56)
	0	0	1	0	0	0	0	8(2π/56)
	0	0	1	0	0	0	1	9(2π/56)
	0	0	1	0	0	1	0	10(2π/56)
	0	0	1	0	0	1	1	11(2π/56)
	0	0	1	1	0	0	0	12(2π/56)
	0	0	1	1	0	0	1	13(2π/56)
	0	0	1	1	0	1	0	14(2π/56)
	0	0	1	1	0	1	1	15(2π/56)
	0	1	0	0	0	0	0	16(2π/56)
	0	1	0	0	0	0	1	17(2π/56)
	0	1	0	0	0	1	0	18(2π/56)
	0	1	0	0	0	1	1	19(2π/56)
	0	1	0	1	0	0	0	20(2π/56)
	0	1	0	1	0	0	1	21(2π/56)
	0	1	0	1	0	1	0	22(2π/56)
	0	1	0	1	0	1	1	23(2π/56)
	0	1	1	0	0	0	0	24(2π/56)
	0	1	1	0	0	0	1	25(2π/56)
	0	1	1	0	0	1	0	26(2π/56)
	0	1	1	0	0	1	1	27(2π/56)
	1	0	0	0	0	0	0	28(2π/56)
	1	0	0	0	0	0	1	29(2π/56)
	1	0	0	0	0	1	0	30(2π/56)
	1	0	0	0	0	1	1	31(2π/56)
	1	0	0	1	0	0	0	32(2π/56)
	1	0	0	1	0	0	1	33(2π/56)
	1	0	0	1	0	1	0	34(2π/56)
	1	0	0	1	0	1	1	35(2π/56)
	1	0	1	0	0	0	0	36(2π/56)
	1	0	1	0	0	0	1	37(2π/56)
	1	0	1	0	0	1	0	38(2π/56)
	1	0	1	0	0	1	1	39(2π/56)
	1	0	1	1	0	0	0	40(2π/56)
	1	0	1	1	0	0	1	41(2π/56)
	1	0	1	1	0	1	0	42(2π/56)
	1	0	1	1	0	1	1	43(2π/56)
	1	1	0	0	0	0	0	44(2π/56)
	1	1	0	0	0	0	1	45(2π/56)
	1	1	0	0	0	1	0	46(2π/56)
	1	1	0	0	0	1	1	47(2π/56)
	1	1	0	1	0	0	0	48(2π/56)
	1	1	0	1	0	0	1	49(2π/56)
	1	1	0	1	0	1	0	50(2π/56)
	1	1	0	1	0	1	1	51(2π/56)
	1	1	1	0	0	0	0	52(2π/56)
	1	1	1	0	0	0	1	53(2π/56)
	1	1	1	0	0	1	0	54(2π/56)
	1	1	1	0	0	1	1	55(2π/56)

Table 18. CDCE62005 Output Coarse Phase Adjust Settings (5)

Divide Ratio	PHnADGC6	PHnADGC5	PHnADGC4	PHnADGC3	PHnADGC2	PHnADGC1	PHnADGC0	Phase Delay (radian)
	n.12	n.11	n.10	n.9	n.8	n.7	n.6	
60	0	0	0	0	0	0	0	0
	0	0	0	0	0	0	1	(2π/60)
	0	0	0	0	0	1	0	2(2π/60)
	0	0	0	0	0	1	1	3(2π/60)
	0	0	0	0	1	0	0	4(2π/60)
	0	0	0	1	0	0	0	5(2π/60)
	0	0	0	1	0	0	1	6(2π/60)
	0	0	0	1	0	1	0	7(2π/60)
	0	0	0	1	0	1	1	8(2π/60)
	0	0	0	1	1	0	0	9(2π/60)
	0	0	1	0	0	0	0	10(2π/60)
	0	0	1	0	0	0	1	11(2π/60)
	0	0	1	0	0	1	0	12(2π/60)
	0	0	1	0	0	1	1	13(2π/60)
	0	0	1	0	1	0	0	14(2π/60)
	0	0	1	1	0	0	0	15(2π/60)
	0	0	1	1	0	0	1	16(2π/60)
	0	0	1	1	0	1	0	17(2π/60)
	0	0	1	1	0	1	1	18(2π/60)
	0	0	1	1	1	0	0	19(2π/60)
	0	1	0	0	0	0	0	20(2π/60)
	0	1	0	0	0	0	1	21(2π/60)
	0	1	0	0	0	1	0	22(2π/60)
	0	1	0	0	0	1	1	23(2π/60)
	0	1	0	0	1	0	0	24(2π/60)
	0	1	0	1	0	0	0	25(2π/60)
	0	1	0	1	0	0	1	26(2π/60)
	0	1	0	1	0	1	0	27(2π/60)
	0	1	0	1	0	1	1	28(2π/60)
	0	1	0	1	1	0	0	29(2π/60)
	1	0	0	0	0	0	0	30(2π/60)
	1	0	0	0	0	0	1	31(2π/60)
	1	0	0	0	0	1	0	32(2π/60)
	1	0	0	0	0	1	1	33(2π/60)
	1	0	0	0	1	0	0	34(2π/60)
	1	0	0	1	0	0	0	35(2π/60)
	1	0	0	1	0	0	1	36(2π/60)
	1	0	0	1	0	1	0	37(2π/60)
	1	0	0	1	0	1	1	38(2π/60)
	1	0	0	1	1	0	0	39(2π/60)
	1	0	1	0	0	0	0	40(2π/60)
	1	0	1	0	0	0	1	41(2π/60)
	1	0	1	0	0	1	0	42(2π/60)
	1	0	1	0	0	1	1	43(2π/60)
	1	0	1	0	1	0	0	44(2π/60)
	1	0	1	1	0	0	0	45(2π/60)
	1	0	1	1	0	0	1	46(2π/60)
	1	0	1	1	0	1	0	47(2π/60)
	1	0	1	1	0	1	1	48(2π/60)
	1	0	1	1	1	0	0	49(2π/60)
	1	1	0	0	0	0	0	50(2π/60)
	1	1	0	0	0	0	1	51(2π/60)
	1	1	0	0	0	1	0	52(2π/60)
	1	1	0	0	0	1	1	53(2π/60)
	1	1	0	0	1	0	0	54(2π/60)
	1	1	0	1	0	0	0	55(2π/60)
	1	1	0	1	0	0	1	56(2π/60)
	1	1	0	1	0	1	0	57(2π/60)
	1	1	0	1	0	1	1	58(2π/60)
	1	1	0	1	1	0	0	59(2π/60)

Divide Ratio	PHnADGC6	PHnADGC5	PHnADGC4	PHnADGC3	PHnADGC2	PHnADGC1	PHnADGC0	Phase Delay (radian)
	n.12	n.11	n.10	n.9	n.8	n.7	n.6	
64	0	0	0	0	0	0	0	0
	0	0	0	0	0	0	1	(2π/64)
	0	0	0	0	0	1	0	2(2π/64)
	0	0	0	0	0	1	1	3(2π/64)
	0	0	0	1	0	0	0	4(2π/64)
	0	0	0	1	0	0	1	5(2π/64)
	0	0	0	1	0	1	0	6(2π/64)
	0	0	0	1	0	1	1	7(2π/64)
	0	0	1	0	0	0	0	8(2π/64)
	0	0	1	0	0	0	1	9(2π/64)
	0	0	1	0	0	1	0	10(2π/64)
	0	0	1	0	0	1	1	11(2π/64)
	0	0	1	1	0	0	0	12(2π/64)
	0	0	1	1	0	0	1	13(2π/64)
	0	0	1	1	0	1	0	14(2π/64)
	0	0	1	1	0	1	1	15(2π/64)
	0	1	0	0	0	0	0	16(2π/64)
	0	1	0	0	0	0	1	17(2π/64)
	0	1	0	0	0	1	0	18(2π/64)
	0	1	0	0	0	1	1	19(2π/64)
	0	1	0	0	0	0	0	20(2π/64)
	0	1	0	0	0	0	1	21(2π/64)
	0	1	0	0	1	0	0	22(2π/64)
	0	1	0	0	1	0	1	23(2π/64)
	0	1	0	0	1	0	0	24(2π/64)
	0	1	0	1	0	0	0	25(2π/64)
	0	1	0	1	0	0	1	26(2π/64)
	0	1	0	1	0	0	1	27(2π/64)
	0	1	0	1	0	1	0	28(2π/64)
	0	1	0	1	1	0	0	29(2π/64)
	0	1	1	0	0	0	0	30(2π/64)
	0	1	1	0	0	0	1	31(2π/64)
	0	1	1	0	0	0	0	32(2π/64)
	0	1	1	0	0	0	1	33(2π/64)
	0	1	1	0	0	0	1	34(2π/64)
	0	1	1	0	0	0	1	35(2π/64)
	0	1	1	0	0	0	0	36(2π/64)
	0	1	1	0	0	0	1	37(2π/64)
	0	1	1	0	0	1	0	38(2π/64)
	0	1	1	0	0	1	1	39(2π/64)
	0	1	1	0	0	0	0	40(2π/64)
	0	1	1	0	0	0	1	41(2π/64)
	0	1	1	0	0	1	0	42(2π/64)
	0	1	1	0	0	1	1	43(2π/64)
	0	1	1	0	0	0	0	44(2π/64)
	0	1	1	0	0	0	1	45(2π/64)
	0	1	1	0	0	1	0	46(2π/64)
	0	1	1	0	0	1	1	47(2π/64)
	0	1	1	0	0	0	0	48(2π/64)
	0	1	1	0	0	0	1	49(2π/64)
	0	1	1	0	0	0	0	50(2π/64)
	0	1	1	0	0	0	1	51(2π/64)
	0	1	1	0	0	0	0	52(2π/64)
	0	1	1	0	0	0	1	53(2π/64)
	0	1	1	0	0	1	0	54(2π/64)
	0	1	1	0	0	1	1	55(2π/64)
	0	1	1	0	0	0	0	56(2π/64)
	0	1	1	0	0	0	1	57(2π/64)
	0	1	1	0	0	1	0	58(2π/64)
	0	1	1	0	0	1	1	59(2π/64)
	0	1	1	0	0	0	0	60(2π/64)
	0	1	1	0	0	0	1	61(2π/64)
	0	1	1	0	0	1	0	62(2π/64)
	0	1	1	0	0	1	1	63(2π/64)

Table 19. CDCE62005 Output Coarse Phase Adjust Settings (6)

Divide Ratio	PHnADGC6	PHnADGC5	PHnADGC4	PHnADGC3	PHnADGC2	PHnADGC1	PHnADGC0	Phase Delay (radian)
	n.12	n.11	n.10	n.9	n.8	n.7	n.6	
70	0	0	0	0	0	0	0	0
	0	0	0	0	0	0	1	(2π/70)
	0	0	0	0	0	1	0	2(2π/70)
	0	0	0	0	0	1	1	3(2π/70)
	0	0	0	0	1	0	0	4(2π/70)
	0	0	0	1	0	0	0	5(2π/70)
	0	0	0	1	0	0	1	6(2π/70)
	0	0	0	1	0	1	0	7(2π/70)
	0	0	0	1	0	1	1	8(2π/70)
	0	0	0	1	1	0	0	9(2π/70)
	0	0	1	0	0	0	0	10(2π/70)
	0	0	1	0	0	0	1	11(2π/70)
	0	0	1	0	0	1	0	12(2π/70)
	0	0	1	0	0	1	1	13(2π/70)
	0	0	1	0	1	0	0	14(2π/70)
	0	0	1	1	0	0	0	15(2π/70)
	0	0	1	1	0	0	1	16(2π/70)
	0	0	1	1	0	1	0	17(2π/70)
	0	0	1	1	0	1	1	18(2π/70)
	0	0	1	1	1	0	0	19(2π/70)
	0	1	0	0	0	0	0	20(2π/70)
	0	1	0	0	0	0	1	21(2π/70)
	0	1	0	0	0	1	0	22(2π/70)
	0	1	0	0	0	1	1	23(2π/70)
	0	1	0	0	1	0	0	24(2π/70)
	0	1	0	1	0	0	0	25(2π/70)
	0	1	0	1	0	0	1	26(2π/70)
	0	1	0	1	0	1	0	27(2π/70)
	0	1	0	1	0	1	1	28(2π/70)
	0	1	0	1	1	0	0	29(2π/70)
	0	1	1	0	0	0	0	30(2π/70)
	0	1	1	0	0	0	1	31(2π/70)
	0	1	1	0	0	1	0	32(2π/70)
	0	1	1	0	0	1	1	33(2π/70)
	0	1	1	0	1	0	0	34(2π/70)
	1	0	0	0	0	0	0	35(2π/70)
	1	0	0	0	0	0	1	36(2π/70)
	1	0	0	0	0	1	0	37(2π/70)
	1	0	0	0	0	1	1	38(2π/70)
	1	0	0	0	1	0	0	39(2π/70)
	1	0	0	1	0	0	0	40(2π/70)
	1	0	0	1	0	0	1	41(2π/70)
	1	0	0	1	0	1	0	42(2π/70)
	1	0	0	1	0	1	1	43(2π/70)
	1	0	0	1	1	0	0	44(2π/70)
	1	0	0	1	0	0	0	45(2π/70)
	1	0	1	0	0	0	1	46(2π/70)
	1	0	1	0	0	1	0	47(2π/70)
	1	0	1	0	0	1	1	48(2π/70)
	1	0	1	0	1	0	0	49(2π/70)
	1	0	1	1	0	0	0	50(2π/70)
	1	0	1	1	0	0	1	51(2π/70)
	1	0	1	1	0	1	0	52(2π/70)
	1	0	1	1	0	1	1	53(2π/70)
	1	0	1	1	1	0	0	54(2π/70)
	1	1	0	0	0	0	0	55(2π/70)
	1	1	0	0	0	0	1	56(2π/70)
	1	1	0	0	0	1	0	57(2π/70)
	1	1	0	0	0	1	1	58(2π/70)
	1	1	0	0	1	0	0	59(2π/70)
	1	1	0	1	0	0	0	60(2π/70)
	1	1	0	1	0	0	1	61(2π/70)
	1	1	0	1	0	1	0	62(2π/70)
	1	1	0	1	0	1	1	63(2π/70)
	1	1	0	1	1	0	0	64(2π/70)
	1	1	1	0	0	0	0	65(2π/70)
	1	1	1	0	0	0	1	66(2π/70)
	1	1	1	0	0	1	0	67(2π/70)
	1	1	1	0	0	1	1	68(2π/70)
	1	1	1	0	1	0	0	69(2π/70)

Divide Ratio	PHnADGC6	PHnADGC5	PHnADGC4	PHnADGC3	PHnADGC2	PHnADGC1	PHnADGC0	Phase Delay (radian)
	n.12	n.11	n.10	n.9	n.8	n.7	n.6	
80	0	0	0	0	0	0	0	0
	0	0	0	0	0	0	1	(2π/80)
	0	0	0	0	0	1	0	2(2π/80)
	0	0	0	0	0	1	1	3(2π/80)
	0	0	0	0	1	0	0	4(2π/80)
	0	0	0	1	0	0	0	5(2π/80)
	0	0	0	1	0	0	1	6(2π/80)
	0	0	0	1	0	1	0	7(2π/80)
	0	0	0	1	0	1	1	8(2π/80)
	0	0	0	1	1	0	0	9(2π/80)
	0	0	1	0	0	0	0	10(2π/80)
	0	0	1	0	0	0	1	11(2π/80)
	0	0	1	0	0	1	0	12(2π/80)
	0	0	1	0	0	1	1	13(2π/80)
	0	0	1	0	1	0	0	14(2π/80)
	0	0	1	1	0	0	0	15(2π/80)
	0	0	1	1	0	0	1	16(2π/80)
	0	0	1	1	0	1	0	17(2π/80)
	0	0	1	1	0	1	1	18(2π/80)
	0	0	1	1	1	0	0	19(2π/80)
	0	1	0	0	0	0	0	20(2π/80)
	0	1	0	0	0	0	1	21(2π/80)
	0	1	0	0	0	1	0	22(2π/80)
	0	1	0	0	0	1	1	23(2π/80)
	0	1	0	0	1	0	0	24(2π/80)
	0	1	0	1	0	0	0	25(2π/80)
	0	1	0	1	0	0	1	26(2π/80)
	0	1	0	1	0	1	0	27(2π/80)
	0	1	0	1	0	1	1	28(2π/80)
	0	1	0	1	1	0	0	29(2π/80)
	0	1	1	0	0	0	0	30(2π/80)
	0	1	1	0	0	0	1	31(2π/80)
	0	1	1	0	0	1	0	32(2π/80)
	0	1	1	0	0	1	1	33(2π/80)
	0	1	1	0	1	0	0	34(2π/80)
	0	1	1	1	0	0	0	35(2π/80)
	0	1	1	1	0	0	1	36(2π/80)
	0	1	1	1	0	1	0	37(2π/80)
	0	1	1	1	0	1	1	38(2π/80)
	0	1	1	1	1	0	0	39(2π/80)
	1	0	0	0	0	0	0	40(2π/80)
	1	0	0	0	0	0	1	41(2π/80)
	1	0	0	0	0	1	0	42(2π/80)
	1	0	0	0	0	1	1	43(2π/80)
	1	0	0	0	1	0	0	44(2π/80)
	1	0	0	1	0	0	0	45(2π/80)
	1	0	0	1	0	0	1	46(2π/80)
	1	0	0	1	0	1	0	47(2π/80)
	1	0	0	1	0	1	1	48(2π/80)
	1	0	0	1	1	0	0	49(2π/80)
	1	0	1	0	0	0	0	50(2π/80)
	1	0	1	0	0	0	1	51(2π/80)
	1	0	1	0	0	1	0	52(2π/80)
	1	0	1	0	0	1	1	53(2π/80)
	1	0	1	0	1	0	0	54(2π/80)
	1	0	1	1	0	0	0	55(2π/80)
	1	0	1	1	0	0	1	56(2π/80)
	1	0	1	1	0	1	0	57(2π/80)
	1	0	1	1	0	1	1	58(2π/80)
	1	0	1	1	1	0	0	59(2π/80)
	1	1	0	0	0	0	0	60(2π/80)
	1	1	0	0	0	0	1	61(2π/80)
	1	1	0	0	0	1	0	62(2π/80)
	1	1	0	0	0	1	1	63(2π/80)
	1	1	0	0	1	0	0	64(2π/80)
	1	1	0	1	0	0	0	65(2π/80)
	1	1	0	1	0	0	1	66(2π/80)
	1	1	0	1	0	1	0	67(2π/80)
	1	1	0	1	0	1	1	68(2π/80)
	1	1	0	1	1	0	0	69(2π/80)
	1	1	1	0	0	0	0	70(2π/80)
	1	1	1	0	0	0	1	71(2π/80)
	1	1	1	0	0	1	0	72(2π/80)
	1	1	1	0	0	1	1	73(2π/80)
	1	1	1	0	1	0	0	74(2π/80)
	1	1	1	1	0	0	0	75(2π/80)
	1	1	1	1	0	0	1	76(2π/80)
	1	1	1	1	0	1	0	77(2π/80)
	1	1	1	1	0	1	1	78(2π/80)
	1	1	1	1	1	0	0	79(2π/80)

8.3.5.14 Output Synchronization

Figure 26 shows the output synchronization circuitry and relative output clock phase position with respect to SYNC signal Low to High phase transition.

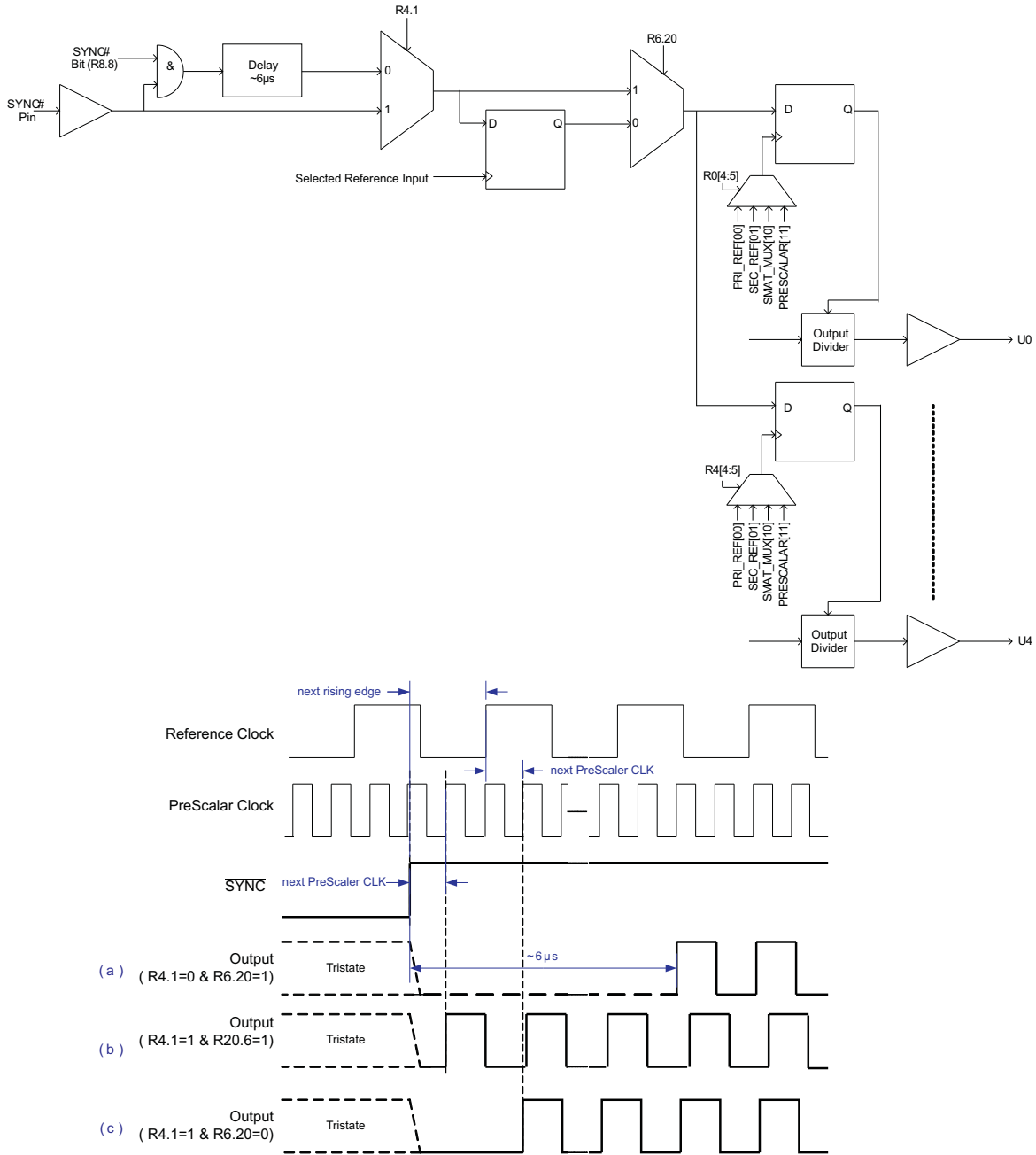

NOTE: The signal diagram is based on the assumption that prescaler clock is selected by output Mux (Rn[4:5] where n = 0, 1, 2, 3 or 4)

Figure 26. Output Synchronization Diagram

The synchronization of the outputs can be accomplished by toggling the SYNC pin, or Bit (R8.8), or by changing any output divider values. Table 20 shows the phase relationship between output phase and the SYNC signal, the selected reference clock and the prescaler output clock phases.

Table 20. Output Synchronization Procedure

	R4.1	R6.20	COMMENTS
Toggling SYNC Pin or Bit (R8.8) from low to high	0	0	The synchronized outputs will be enabled after ~6 μs delay and the next rising edge of the reference clock and selected clock of output multiplexer.
	0	1	The synchronized outputs will be enabled after ~6 μs delay and the next rising edge of selected clock of output multiplexer (reference Figure 26 (a)).
	1	0	The synchronized outputs will be enabled with the next rising edge of reference clock & the selected clock of output multiplexer (reference Figure 26 (c)).
	1	1	The synchronized outputs will be enabled with the next rising edge of the selected clock of output multiplexer (reference Figure 26 (b)).
Toggling SYNC Pin or Bit (R8.8) from high to low	X	X	All outputs are disabled.

8.3.5.15 Auxiliary Output

[Figure 27](#) shows the auxiliary output port. [Table 21](#) lists how the auxiliary output port is controlled. The output buffer supports a maximum output frequency of 250 MHz and drives at LVCMOS levels. Refer to [Table 13](#) for the list of divider settings that establishes the output frequency.

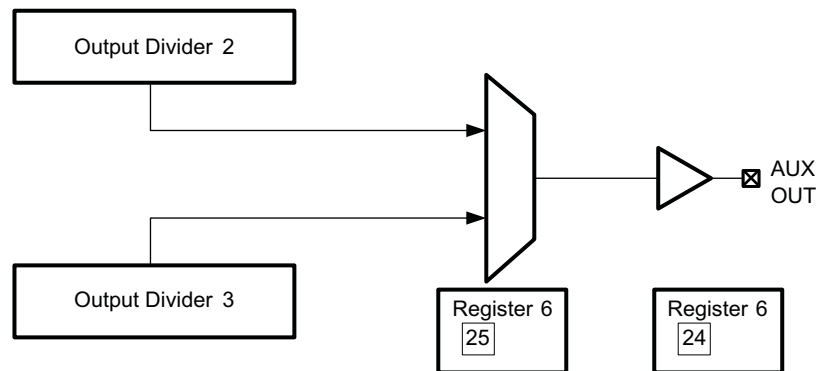

Figure 27. CDCE62005 Auxiliary Output

Table 21. CDCE62005 Auxiliary Output Settings

BIT NAME → REGISTER.BIT →	AUXFEEDSEL	AUXOUTEN	AUX OUTPUT SOURCE
	6.25	6.24	
	X	0	OFF
	0	1	Divider 2 ⁽¹⁾
	1	1	Divider 3 ⁽¹⁾

(1) If Divider 2 or Divider 3 is set to divide by 1 and AUXOUT is selected from divide by 1, then AUXOUT will be disabled even if the AUXOUTEN bit (6.24) is high.

8.3.5.16 Synthesizer Block

Figure 28 provides an overview of the CDCE62005 synthesizer block. The Synthesizer Block provides a Phase Locked Loop, a partially integrated programmable loop filter, and two Voltage Controlled Oscillators (VCO). The synthesizer block generates an output clock called “SYNTH” and drives it onto the Internal Clock Distribution Bus.

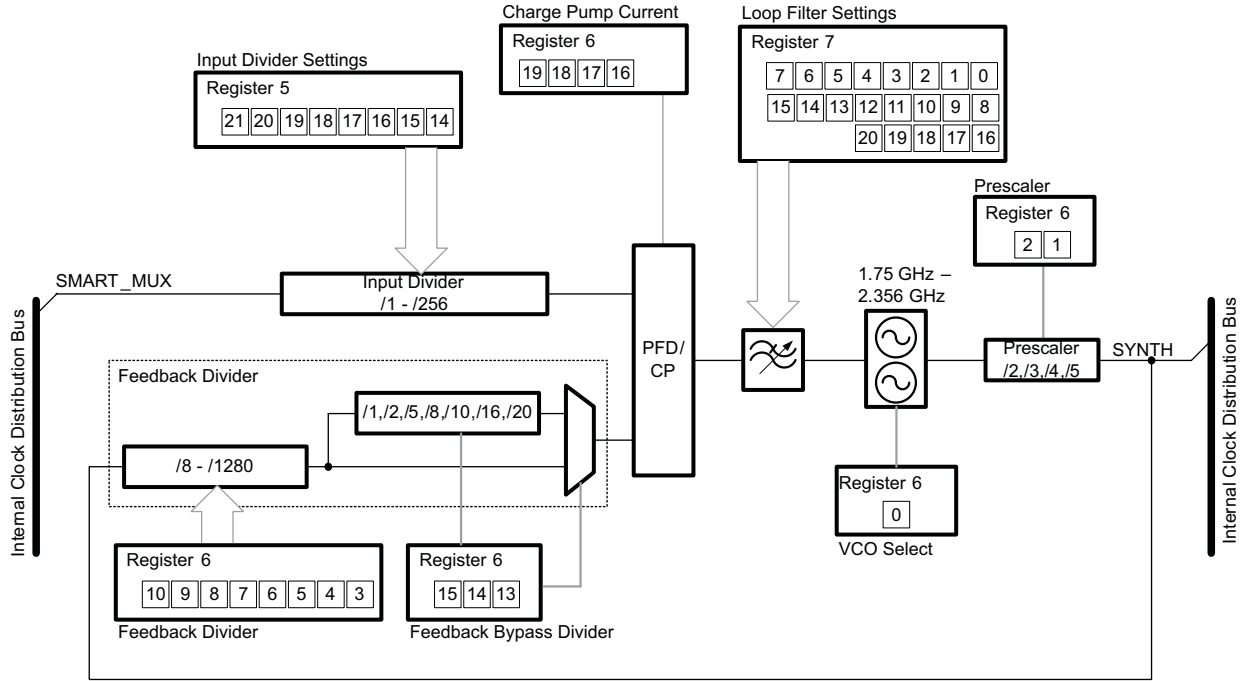

Figure 28. CDCE62005 Synthesizer Block

8.3.5.17 Input Divider

The Input Divider divides the clock signal selected by the Smart Multiplexer (see Table 7) and presents the divided signal to the Phase Frequency Detector / Charge Pump of the frequency synthesizer.

Table 22. CDCE62005 Input Divider Settings

INPUT DIVIDER SETTINGS								DIVIDE RATIO
SELINDIV7	SELINDIV6	SELINDIV5	SELINDIV4	SELINDIV3	SELINDIV2	SELINDIV1	SELINDIV0	
5.21	5.20	5.19	5.18	5.17	5.16	5.15	5.14	
0	0	0	0	0	0	0	0	1
0	0	0	0	0	0	0	1	2
0	0	0	0	0	0	1	0	3
0	0	0	0	0	0	1	1	4
0	0	0	0	0	1	0	0	5
0	0	0	0	0	1	0	1	6
•	•	•	•	•	•	•	•	•
•	•	•	•	•	•	•	•	•
1	1	1	1	1	1	1	1	256

8.3.5.18 Feedback and Feedback Bypass Divider

Table 23 shows how to configure the Feedback divider for various divide values

Table 23. CDCE62005 Feedback Divider Settings

FEEDBACK DIVIDER								DIVIDE RATIO
SELFBDIV7	SELFBDIV6	SELFBDIV5	SELFBDIV4	SELFBDIV3	SELFBDIV2	SELFBDIV1	SELFBDIV0	
6.10	6.9	9.8	6.7	6.6	6.5	6.4	6.3	
0	0	0	0	0	0	0	0	8
0	0	0	0	0	0	0	1	12
0	0	0	0	0	0	1	0	16
0	0	0	0	0	0	1	1	20
0	0	0	0	0	1	0	1	24
0	0	0	0	0	1	1	0	32
0	0	0	0	1	0	0	1	36
0	0	0	0	0	1	1	1	40
0	0	0	0	1	0	1	0	48
0	0	0	1	1	0	0	0	56
0	0	0	0	1	0	1	1	60
0	0	0	0	1	1	1	0	64
0	0	0	1	0	1	0	1	72
0	0	0	0	1	1	1	1	80
0	0	0	1	1	0	0	1	84
0	0	0	1	0	1	1	0	96
0	0	0	1	0	0	1	1	100
0	1	0	0	1	0	0	1	108
0	0	0	1	1	0	1	0	112
0	0	0	1	0	1	1	1	120
0	0	0	1	1	1	1	0	128
0	0	0	1	1	0	1	1	140
0	0	1	1	0	1	0	1	144
0	0	0	1	1	1	1	1	160
0	0	1	1	1	0	0	1	168
0	1	0	0	1	0	1	1	180
0	0	1	1	0	1	1	0	192
0	0	1	1	0	0	1	1	200
0	1	0	1	0	1	0	1	216
0	0	1	1	1	0	1	0	224
0	0	1	1	0	1	1	1	240
0	1	0	1	1	0	0	1	252
0	0	1	1	1	1	1	0	256
0	0	1	1	1	0	1	1	280
0	1	0	1	0	1	1	0	288
0	1	0	1	0	0	1	1	300
0	0	1	1	1	1	1	1	320
0	1	0	1	1	0	1	0	336
0	1	0	1	0	1	1	1	360
0	1	0	1	1	1	1	0	384
1	1	0	1	1	0	0	0	392
0	1	1	1	0	0	1	1	400

Table 23. CDCE62005 Feedback Divider Settings (continued)

FEEDBACK DIVIDER								DIVIDE RATIO
SELFBDIV7	SELFBDIV6	SELFBDIV5	SELFBDIV4	SELFBDIV3	SELFBDIV2	SELFBDIV1	SELFBDIV0	
6.10	6.9	9.8	6.7	6.6	6.5	6.4	6.3	
0	1	0	1	1	0	1	1	420
1	0	1	1	0	1	0	1	432
0	1	1	1	1	0	1	0	448
0	1	0	1	1	1	1	1	480
1	0	0	1	0	0	1	1	500
1	0	1	1	1	0	0	1	504
0	1	1	1	1	1	1	0	512
0	1	1	1	1	0	1	1	560
1	0	1	1	0	1	1	0	576
1	1	0	1	1	0	0	1	588
1	0	0	1	0	1	1	1	600
0	1	1	1	1	1	1	1	640
1	0	1	1	1	0	1	0	672
1	0	0	1	1	0	1	1	700
1	0	1	1	0	1	1	1	720
1	0	1	1	1	1	1	0	768
1	1	0	1	1	0	1	0	784
1	0	0	1	1	1	1	1	800
1	0	1	1	1	0	1	1	840
1	1	0	1	1	1	1	0	896
1	0	1	1	1	1	1	1	960
1	1	0	1	1	0	1	1	980
1	1	1	1	1	1	1	0	1024
1	1	0	1	1	1	1	1	1120
1	1	1	1	1	1	1	1	1280

Table 24 shows how to configure the Feedback Bypass Divider.

Table 24. CDCE62005 Feedback Bypass Divider Settings

FEEDBACK BYPASS DIVIDER			DIVIDE RATIO
SELBPDIV2	SELBPDIV1	SELBPDIV0	
6.15	6.14	6.13	
0	0	0	2
0	0	1	5
0	1	0	8
0	1	1	10
1	0	0	16
1	0	1	20
1	1	0	RESERVED
1	1	1	1(bypass)

8.3.5.18.1 VCO Select

Table 25 illustrates how to control the dual voltage controlled oscillators.

Table 25. CDCE62005 VCO Select

BIT NAME → REGISTER.BIT →	VCO SELECT SELVCO	VCO CHARACTERISTICS		
	6.0	VCO RANGE	Fmin (MHz)	Fmax (MHz)
	0	Low	1750	2046
	1	High	2040	2356

8.3.5.18.2 Prescaler

Table 26 shows how to configure the prescaler.

Table 26. CDCE62005 Prescaler Settings

SETTINGS		DIVIDE RATIO
SELPRESCB	SELPRESCA	
6.2	6.1	
0	0	5
1	0	4
0	1	3
1	1	2

8.3.5.18.3 Charge Pump Current Settings

Table 27 provides the settings for the charge pump:

Table 27. CDCE62005 Charge Pump Settings

BIT NAME → REGISTER.BIT →	CHARGE PUMP SETTINGS				CHARGE PUMP CURRENT
	ICPSEL3	ICPSEL2	ICPSEL1	ICPSEL0	
	6.19	6.18	6.17	6.16	
	0	0	0	0	50 μ A
	0	0	0	1	100 μ A
	0	0	1	0	150 μ A
	0	0	1	1	200 μ A
	0	1	0	0	300 μ A
	0	1	0	1	400 μ A
	0	1	1	0	600 μ A
	0	1	1	1	750 μ A
	1	0	0	0	1 mA
	1	0	0	1	1.25 mA
	1	0	1	0	1.5 mA
	1	0	1	1	2 mA
	1	1	0	0	2.5 mA
	1	1	0	1	3 mA
	1	1	1	0	3.5 mA
	1	1	1	1	3.75 mA

8.3.5.18.4 Loop Filter

Figure 29 depicts the loop filter topology of the CDCE62005. It facilitates both internal and external implementations providing optimal flexibility.

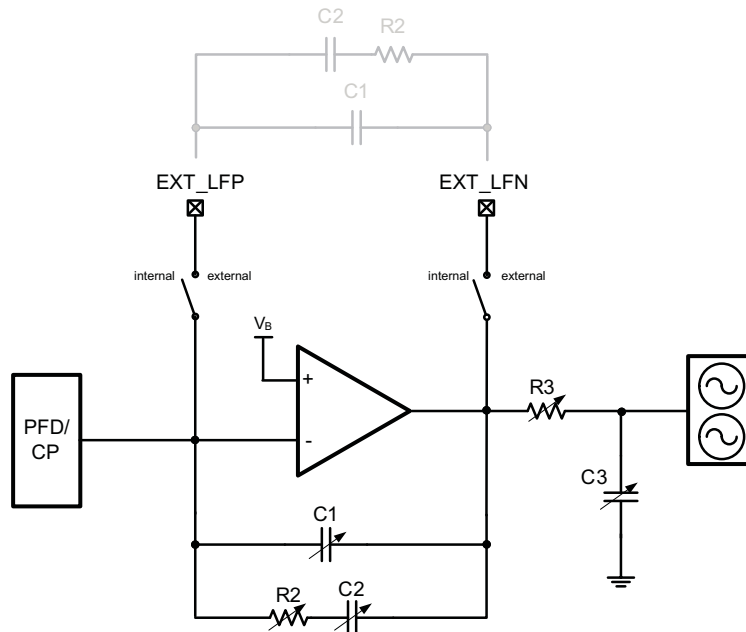

Figure 29. CDCE62005 Loop Filter Topology

8.3.5.19 Internal Loop Filter Component Configuration

Figure 29 contains five different loop filter components with programmable values: C1, C2, R2, R3, and C3. Table 28 shows that the CDCE62005 uses one of four different types of circuit implementation (shown in Figure 30) for each of the internal loop filter components.

Table 28. CDCE62005 Loop Filter Component Implementation Type

COMPONENT	CONTROL BITS USED	IMPLEMENTATION TYPE (see Figure 30)
C1	5	a
C2	5	a
R2	5	c
R3	2	d
C3	4	b

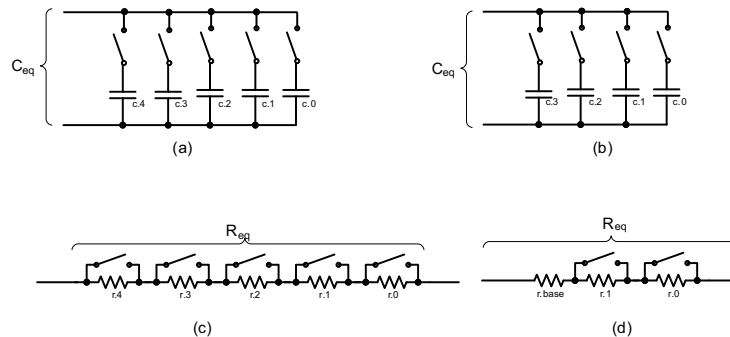

Figure 30. CDCE62005 Internal Loop Filter Component Schematics

Table 29. CDCE62005 Internal Loop Filter – C1 Settings

BIT NAME → CAPACITOR VALUE → REGISTER.BIT →	C1 SETTINGS						CAPACITOR VALUE
	EXLFSSEL	LFRCSSEL14	LFRCSSEL13	LFRCSSEL12	LFRCSSEL11	LFRCSSEL10	
	—	37.5 pF	21.5 pF	10 pF	6.5 pF	1.5 pF	
	6.26	7.14	7.13	7.12	7.11	7.10	External Loop Filter
	1	0	0	0	0	0	0 pF
	0	0	0	0	0	0	1.5 pF
	0	0	0	0	1	0	6.5 pF
	0	0	0	0	1	1	8 pF
	0	0	0	1	0	0	10 pF
	0	0	0	1	0	1	11.5 pF
	0	0	0	1	1	0	16.5 pF
	0	0	0	1	1	1	18 pF
	0	0	1	0	0	0	21.5 pF
	0	0	1	0	0	1	23 pF
	0	•	•	•	•	•	•
	0	1	1	1	0	0	69 pF
	0	1	1	1	0	1	70.5 pF
	0	1	1	1	1	0	75.5 pF
	0	1	1	1	1	1	77 pF

Table 30. CDCE62005 Internal Loop Filter – C2 Settings

BIT NAME → CAPACITOR VALUE → REGISTER.BIT →	C2 SETTINGS						CAPACITOR VALUE
	EXLFSSEL	LFRCSSEL4	LFRCSSEL3	LFRCSSEL2	LFRCSSEL1	LFRCSSEL0	
	—	226 pF	123 pF	87 pF	25 pF	12.5 pF	
	6.26	7.4	7.3	7.2	7.1	7.0	External Loop Filter
	1	0	0	0	0	0	0 pF
	0	0	0	0	0	0	12.5 pF
	0	0	0	0	1	0	25 pF
	0	0	0	0	1	1	37.5 pF
	0	0	0	1	0	0	87 pF
	0	0	0	1	0	1	99.5 pF
	0	0	0	1	1	0	112 pF
	0	0	0	1	1	1	124.5 pF
	0	0	1	0	0	0	123 pF
	0	0	1	0	0	1	135.5 pF
	0	•	•	•	•	•	•
	0	1	1	1	0	0	436 pF
	0	1	1	1	0	1	448.5 pF
	0	1	1	1	1	0	461 pF
	0	1	1	1	1	1	473.5 pF

Table 31. CDCE62005 Internal Loop Filter – R2 Settings

BIT NAME → RESISTOR VALUE → REGISTER.BIT →	R2 SETTINGS						RESISTOR VALUE (kΩ)
	EXLFSSEL	LFRCSSEL9	LFRCSSEL8	LFRCSSEL7	LFRCSSEL6	LFRCSSEL5	
	—	56.4 k	38.2 k	20 k	9 k	4 k	
	6.26	7.9	7.8	7.7	7.6	7.5	
	1	X	X	X	X	X	External Loop Filter
	0	0	0	0	0	0	127.6
	0	0	0	0	0	1	123.6
	0	0	0	0	1	0	118.6
	0	0	0	0	1	1	114.6
	0	0	0	1	0	0	107.6
	0	0	0	1	0	1	103.6
	0	0	0	1	1	0	98.6
	0	0	0	1	1	1	94.6
	0	0	1	0	0	0	89.4
	0	0	1	0	0	1	85.4
	0	•	•	•	•	•	•
	0	1	1	1	0	0	13
	0	1	1	1	0	1	9
	0	1	1	1	1	0	4
	0	1	1	1	1	1	0

Table 32. CDCE62005 Internal Loop Filter – C3 Settings

BIT NAME → CAPACITOR VALUE → REGISTER.BIT →	C3 SETTINGS				CAPACITOR VALUE
	LFRCSSEL18	LFRCSSEL17	LFRCSSEL16	LFRCSSEL15	
	85 pF	19.5 pF	5.5 pF	2.5 pF	
	7.18	7.17	7.16	7.15	
	0	0	0	0	0 pF
	0	0	0	1	2.5 pF
	0	0	1	0	5.5 pF
	0	0	1	1	8 pF
	0	1	0	0	19.5 pF
	0	1	0	1	22 pF
	0	1	1	0	25 pF
	0	1	1	1	27.5 pF
	1	0	0	0	85 pF
	1	0	0	1	87.5 pF
	•	•	•	•	•
	1	1	1	0	104.5 pF
	1	1	1	1	107 pF
	1	1	1	0	110 pF
	1	1	1	1	112.5 pF

Table 33. CDCE62005 Internal Loop Filter – R3 Settings

BIT NAME → RESISTOR VALUE → REGISTER.BIT →	R3 SETTINGS		RESISTOR VALUE (kΩ)
	LFRCSSEL20	LFRCSSEL19	
	10 k	5 k	
	7.20	7.19	
	0	0	20

Table 33. CDCE62005 Internal Loop Filter – R3 Settings (continued)

BIT NAME → RESISTOR VALUE → REGISTER.BIT →	R3 SETTINGS		RESISTOR VALUE (kΩ)
	LFRSEL20 →	LFRSEL19	
	10 k	5 k	
	7.20	7.19	
	0	1	15
	1	0	10
	1	1	5

8.3.5.20 External Loop Filter Component Configuration

To implement an external loop filter, set EXLFSSEL bit (6.26) high. Setting all of the control switches low that control capacitors C1 and C2 (see Table 29 and Table 30) remove them from the loop filter circuit. This is necessary for an external loop filter implementation.

8.3.6 Digital Lock Detect

The CDCE62005 provides both an analog and a digital lock detect circuit. With respect to lock detect, two signals whose phase difference is less than a prescribed amount are ‘locked’ otherwise they are ‘unlocked’. The phase frequency detector / charge pump compares the clock provided by the input divider and the feedback divider; using the input divider as the phase reference. The digital lock detect circuit implements a programmable lock detect window. Table 34 shows an overview of how to configure the digital lock detect feature. When selecting the digital PLL lock option, the PLL_LOCK pin will possibly jitter several times between lock and out of lock until the PLL achieves a stable lock. If desired, choosing a wide loop bandwidth and a high number of successive clock cycles virtually eliminates this characteristic. PLL_LOCK will return to out of lock, if just one cycle is outside the lock detect window or if a cycle slip occurs.

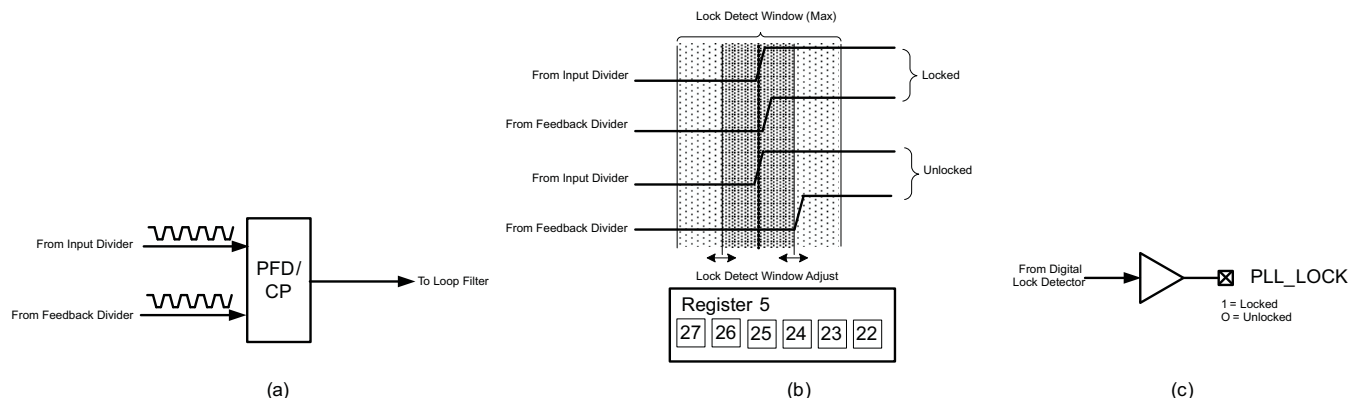

Figure 31. CDCE62005 Digital Lock Detect

Table 34. CDCE62005 Lock Detect Window

BIT NAME → REGISTER.BIT →	DIGITAL LOCK DETECT				LOCK DETECT WINDOW
	LOCKW(3) 5.25	LOCKW(2) 5.24	LOCKW(1) 5.23	LOCKW(0) 5.22	
	0	0	0	0	1.5 ns
	0	0	0	1	5.8 ns
	0	0	1	0	15.1 ns
	0	0	1	1	Reserved
	0	1	0	0	3.4 ns
	0	1	0	1	7.7 ns
	0	1	1	0	17.0 sn
	0	1	1	1	Reserved
	1	0	0	0	5.4 ns
	1	0	0	1	9.7 ns
	1	0	1	0	19.0 ns
	1	0	1	1	Reserved
	1	1	0	0	15.0 ns
	1	1	0	1	19.3 ns
	1	1	1	0	28.6 ns
	1	1	1	1	Reserved

8.3.7 Crystal Input Interference

Fundamental mode is the recommended oscillation mode of operation for the input crystal and parallel resonance is the recommended type of circuit for the crystal.

A crystal load capacitance refers to all capacitances in the oscillator feedback loop. It is equal to the amount of capacitance seen between the terminals of the crystal in the circuit. For parallel resonant mode circuits, the correct load capacitance is necessary to ensure the oscillation of the crystal within the expected parameters.

The CDCE62005 implements an input crystal oscillator circuitry, known as the *Colpitts oscillator*, and requires one pad of the crystal to interface with the AUX IN pin; the other pad of the crystal is tied to ground. In this crystal interface, it is important to account for all sources of capacitance when calculating the correct value for the discrete capacitor component, C_L , for a design.

The CDCE62005 has been characterized with 10-pF parallel resonant crystals. The input crystal oscillator stage in the CDCE62005 is designed to oscillate at the correct frequency for all parallel resonant crystals with low-pull capability and rated with a load capacitance that is equal to the sum of the on-chip load capacitance at the AUX IN pin (10-pF), crystal stray capacitance, and board parasitic capacitance between the crystal and AUX IN pin.

The normalized frequency error of the crystal, as a result of load capacitance mismatch, can be calculated as [Equation 8](#):

$$\frac{\Delta f}{f} = \frac{C_S}{2(C_{L,R} + C_O)} - \frac{C_S}{2(C_{L,A} + C_O)}$$

where

- Δf is the frequency error of the crystal
- f is the rated frequency of the crystal
- C_S is the motional capacitance of the crystal
- $C_{L,R}$ is the rated load capacitance for the crystal
- C_O is the shunt capacitance of the crystal
- $C_{L,A}$ is the actual load capacitance in the implemented PCB for the crystal

(8)

The first three parameters can be obtained from the crystal vendor.

In order to minimize the frequency error of the crystal to meet application requirements, the difference between the rated load capacitance and the actual load capacitance should be minimized and a crystal with low-pull capability (low C_S) should be used.

For example, if an application requires less than ± 50 ppm frequency error and a crystal with less than ± 50 ppm frequency tolerance is picked, the characteristics are as follows: $C_O = 7$ pF, $C_S = 10$ μ F, and $C_{L,R} = 12$ pF. In order to meet the required frequency error, calculate $C_{L,A}$ using [Equation 8](#) to be 17 pF. Subtracting $C_{L,R}$ from $C_{L,A}$, results in 5 pF. Take care to ensure that the sum of the crystal stray capacitance and board parasitic capacitance is less than the calculated 5 pF during printed circuit board (PCB) layout with the crystal and the CDCE62005. Good layout practices are fundamental to the correct operation and reliability of the oscillator. It is critical to locate the crystal components very close to the XIN pin to minimize routing distances. Long traces in the oscillator circuit are a very common source of problems. Do not route other signals across the oscillator circuit. Also, make sure power and high-frequency traces are routed as far away as possible to avoid crosstalk and noise coupling. Avoid the use of vias; if the routing becomes very complex, it is better to use 0- Ω resistors as bridges to go over other signals. Vias in the oscillator circuit should only be used for connections to the ground plane. Do not share ground connections; instead, make a separate connection to ground for each component that requires grounding. If possible, place multiple vias in parallel for each connection to the ground plane. Especially in the Colpitts oscillator configuration, the oscillator is very sensitive to capacitance in parallel with the crystal. Therefore, the layout must be designed to minimize stray capacitance across the crystal to less than 5 pF total under all circumstances to ensure proper crystal oscillation. Be sure to take into account both PCB and crystal stray capacitance.

8.3.8 VCO Calibration

The CDCE62005 includes two on-chip LC oscillator-based VCOs with low phase noise covering a frequency range of 1.75 GHz to 2.356 GHz. The VCO must be calibrated to ensure proper operation over the valid device operating conditions. VCO calibration is controlled by the reference clock input. This calibration requires that the PLL be set up properly to lock the PLL loop and that the reference clock input be present.

The device enters self-calibration of the VCO automatically at power up at device default mode, after the registers have been loaded from the EEPROM and an input clock signal is detected. If there is no input clock available during power up, the VCO will wait for the reference clock before starting calibration.

If the input signal is not valid during self-calibration, it is necessary to re-initiate VCO calibration after the input clock signal stabilizes.

NOTE

Re-calibration is also necessary anytime a PLL setting is changed (for example, divider ratios in the PLL or loop filter settings are adjusted).

VCO calibration can be initiated by writing to register 6 bits 27 and 22 or register 8 bit 7 (/SLEEP bit).

Table 35. VCO Calibration Method Through Register Programming

ENCAL_MODE Bit 6.27	VCO CALIBRATION MECHANISM ⁽¹⁾	REMARKS
1	VCO calibration starts at ENCAL bit (Register 6 bit 22) toggling low-to-high.	The outputs turn off for the duration of the calibration, which are a few ns. This implementation is recommended when the VCO needs to be re-calibrated quickly after a PLL setting was changed. No device block is powered down during this calibration.
0	Device is powered down when $\overline{\text{SLEEP}}$ bit (Register 8 bit 7) is toggle 1-to-0. After asserting $\overline{\text{SLEEP}}$ from zero to one the VCO becomes calibrated.	All outputs are disabled while $\overline{\text{SLEEP}}$ bit is zero. This implementation is an alternative implementation to option one. It takes a longer duration, as all device blocks are powered down while $\overline{\text{SLEEP}}$ is low.

(1) A VCO calibration is also initiated if the external PD pin is toggle high-low-high and the ENCAL_MODE bit (Register 6 bit 27) is preset to 0. In this case all EEPROM registers become reloaded into the device.

8.3.9 Startup Time Estimation

The CDCE62005 startup time can be estimated based on the parameters defined in [Table 36](#) and graphically shown in [Figure 32](#). See also [CDCE62005 SERDES Startup Mode](#).

Table 36. Startup Time Dependencies

PARAMETER	DEFINITION	DESCRIPTION	METHOD OF DETERMINATION
t_{pul}	Power-up time (low limit)	Power-supply rise time to low limit of Power On Reset (POR) trip point	Time required for power supply to ramp to 2.27 V
t_{puh}	Power-up time (high limit)	Power-supply rise time to high limit of Power On Reset (POR) trip point	Time required for power supply to ramp to 2.64 V
t_{rsu}	Reference start-up time	After POR releases, the Colpitts oscillator is enabled. This start-up time is required for the oscillator to generate the requisite signal levels for the delay block to be clocked by the reference input	500 μ s best-case and 800 μ s worst-case (This is only for crystal connected to AUX IN)
t_{delay}	Delay time	Internal delay time generated from the clock. This delay provides time for the oscillator to stabilize.	$t_{delay} = 16384 \times t_{id}$ t_{id} = period of input clock to the input divider
t_{VCO_CAL}	VCO calibration time	VCO calibration time generated from the PFD clock. This process selects the operating point for the VCO based on the PLL settings.	$t_{VCO_CAL} = 550 \times t_{PFD}$ t_{PFD} = period of the PFD clock
t_{PLL_LOCK}	PLL lock time	Time required for PLL to lock within ± 10 ppm of reference frequency	$t_{PLL_LOCK} = 3/LBW$ LBW = PLL Loop Bandwidth

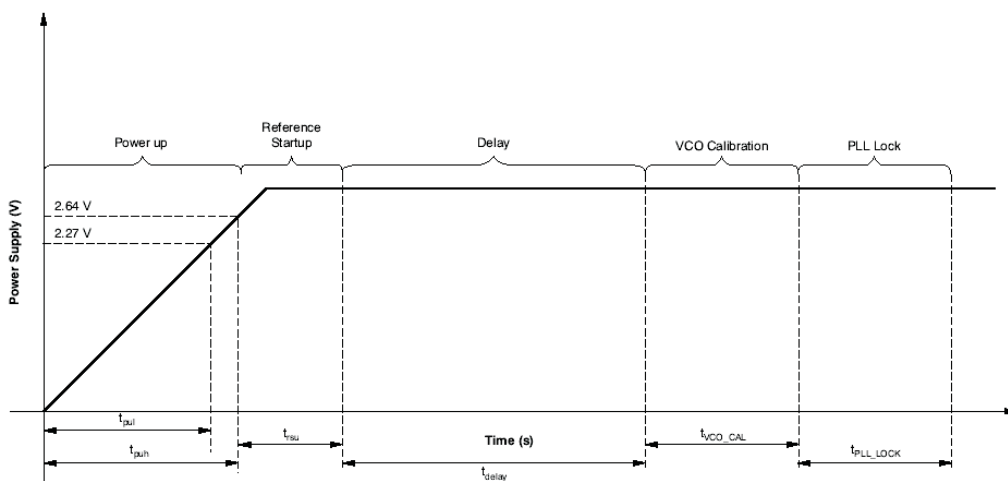

Figure 32. Start-up Time Dependencies

8.3.10 Analog Lock Detect

Figure 33 shows the Analog Lock Detect circuit. Depending upon the phase relationship of the two signals presented at the PFD/CP inputs, the lock detect circuit either charges (if the PLL is locked) or discharges (if PLL is unlocked) the circuit shown via 110µA current sources. An external capacitor determines the sensitivity of the lock detect circuit. The value of the capacitor determines the rate of change of the voltage presented on the output pin PLL_LOCK and hence how quickly the PLL_LOCK output toggles based on a change of PLL locked status. The PLL_LOCK pin is an analog output in analog lock detect mode.

$$V_{out} = \frac{1}{C} \times i \times t \tag{9}$$

Solving for t yields:

$$t = \frac{V_{out} \times C}{i} \tag{10}$$

$$V_H = 0.55 \times V_{CC} \tag{11}$$

$$V_L = 0.35 \times V_{CC} \tag{12}$$

For Example, let:

$$C = 10 \text{ nF}$$

$$V_{CC} = 3.3 \text{ V} \therefore V_H \cong 1.8 \text{ V} = V_{Out}$$

$$t = \frac{1.8 \times 10 \text{ n}}{110 \mu} \cong 164 \mu \text{ s} \tag{13}$$

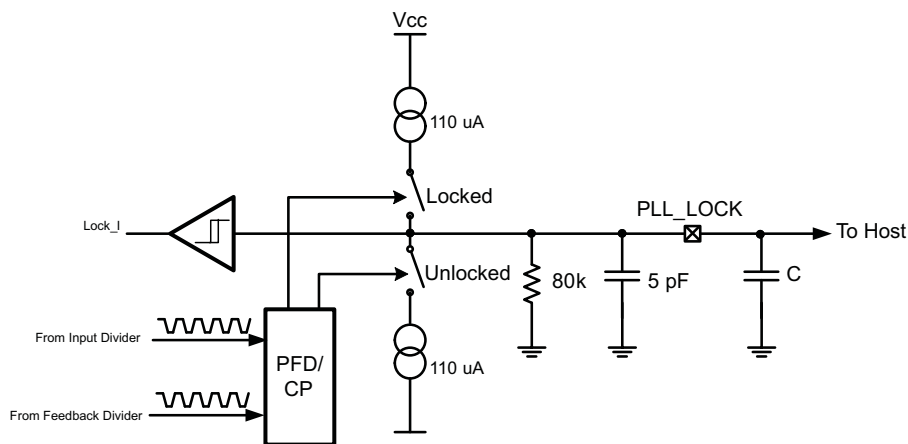

Figure 33. CDCE62005 Analog Lock Detect

8.4 Device Functional Modes

8.4.1 Fan-Out Buffer

Each output of the CDCE62005 can be configured as a fan-out buffer (divider bypassed) or fan-out buffer with divide and skew control functionality.

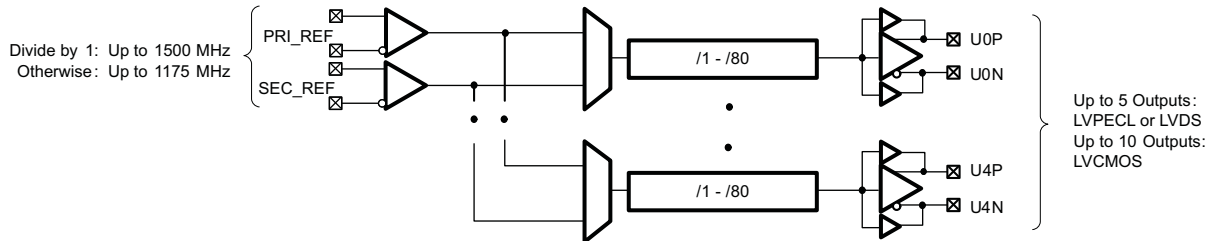

Figure 34. CDCE62005 Fan-out Buffer Mode

8.4.2 Clock Generator

The CDCE62005 can generate 5–10 low noise clocks from a single crystal as follows:

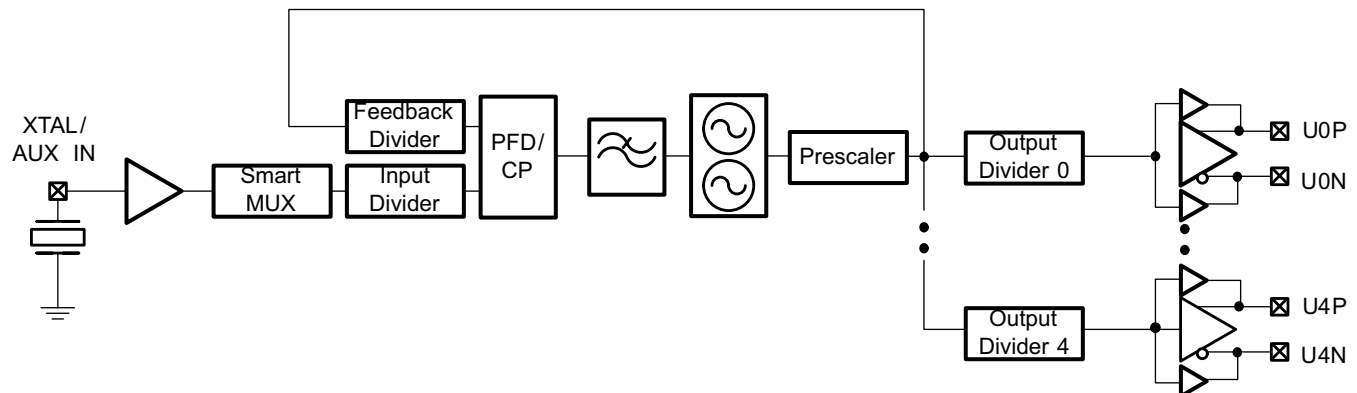

Figure 35. CDCE62005 Clock Generator Mode

8.4.3 Jitter Cleaner – Mixed Mode

The following table presents a common scenario. The CDCE62005 must generate several clocks from a reference that has traversed a backplane. In order for jitter cleaning to take place, the phase noise of the on-board clock path must be better than that of the incoming clock. The designer must pay attention to the optimization of the loop bandwidth of the synthesizer and understand the phase noise profiles of the oscillators involved. Further, other devices on the card require clocks at frequencies not related to the backplane clock. The system requires combinations of differential and single-ended clocks in specific formats with specific phase relationships.

NOTE

Pay special attention when using the universal inputs with two different clock sources. Two clocks derived from the same source may use the internal bias generator and internal termination network without jitter performance degradation. However, if their origin is from different sources (two independent oscillators, for example) then sharing the internal bias generator can degrade jitter performance significantly.

Device Functional Modes (continued)

Table 37. Clock Frequencies

CLOCK FREQUENCY	INPUT/OUTPUT	FORMAT	NUMBER	CDCE62005 PORT	COMMENT
10.000 MHz	Input	LVDS	1	SEC_REF	Low end crystal oscillator
30.72 MHz	Input	LVDS	1	PRI_REF	Reference from backplane
122.88 MHz	Output	LVDS	1	U0	SERDES Clock
491.52 MHz	Output	LVPECL	1	U1	ASIC
245.76 MHz	Output	LVPECL	1	U2	FPGA
30.72 MHz	Outputs	LVC MOS	2	U3	ASIC
10.000 MHz	Outputs	LVC MOS	2	U4	CPU, DSP

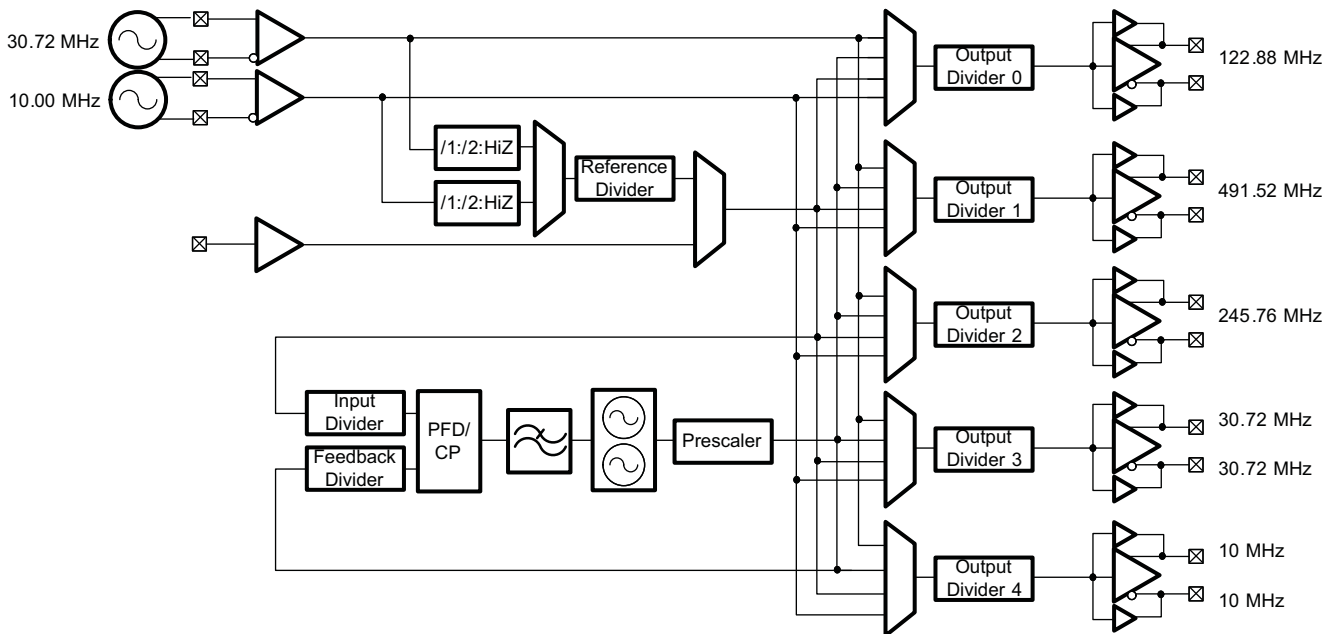

Figure 36. CDCE62005 Jitter Cleaner Example

8.4.3.1 Clocking ADCs with the CDCE62005

High-speed analog to digital converters incorporate high input bandwidth on both the analog port and the sample clock port. Often the input bandwidth far exceeds the sample rate of the converter. Engineers regularly implement receiver chains that take advantage of the characteristics of bandpass sampling. This implementation trend often causes engineers working in communications system design to encounter the term *clock limited performance*. Therefore, it is important to understand the impact of clock jitter on ADC performance. Equation 14 shows the relationship of data converter signal to noise ratio (SNR) to total jitter.

$$SNR_{\text{jitter}} = 20 \log_{10} \left[\frac{1}{2\pi f_{\text{in}} \text{jitter}_{\text{total}}} \right] \quad (14)$$

Total jitter comprises two components: the intrinsic aperture jitter of the converter and the jitter of the sample clock:

$$\text{jitter}_{\text{total}} = \sqrt{(\text{jitter}_{\text{ADC}})^2 + (\text{jitter}_{\text{CLK}})^2} \quad (15)$$

With respect to an ADC with N-bits of resolution, ignoring total jitter, DNL, and input noise, the following equation shows the relationship between resolution and SNR:

$$SNR_{\text{ADC}} = 6.02N + 1.76 \quad (16)$$

Figure 37 plots Equation 14 and Equation 16 for constant values of total jitter. When used in conjunction with most ADCs, the CDCE62005 supports a total jitter performance value of <1 ps.

Data Converter Jitter Requirements

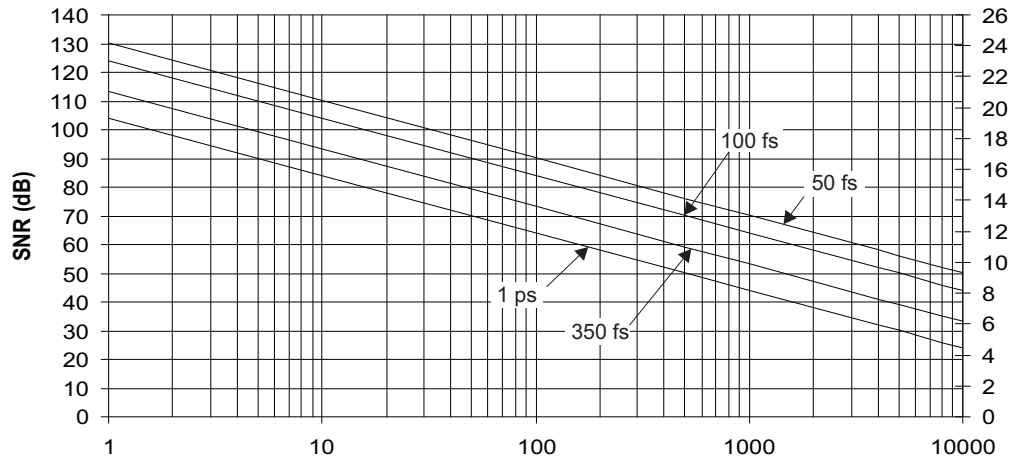

Figure 37. Data Converter Jitter Requirements

8.4.3.2 CDCE62005 SERDES Startup Mode

A common scenario involves a host communicating to a satellite system via a high-speed wired communications link. Typical communications media might be a cable, backplane, or fiber. The reference clock for the satellite system is embedded in the high speed link. This reference clock must be recovered by the SERDES, however, the recovered clock contains unacceptable levels of jitter due to a degradation of SNR associated with transmission over the media. At system startup, the satellite system must self-configure prior to the recovery and cleanup of the reference clock provided by the host. Furthermore, upon loss of the communication link with the host, the satellite system must continue to operate albeit with limited functionality. Figure 38 shows a block diagram of an optical based system with such a mechanism that takes advantage of the features of the CDCE62005:

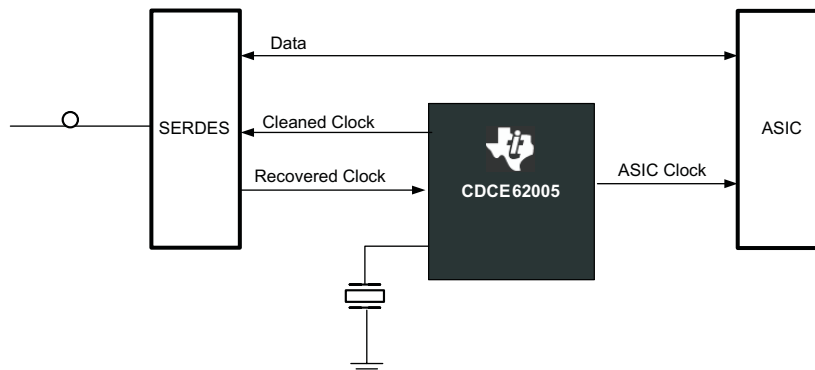

Figure 38. CDCE62005 SERDES Startup Overview

The functionality provided by the Smart Multiplexer provides a straightforward implementation of a SERDES clock link. The Auxiliary Input provides a startup clock because it connects to a crystal. The on-chip EEPROM determines the default configuration at power-up. Therefore, the CDCE62005 requires no host communication to begin cleaning the recovered clock once it is available. The CDCE62005 immediately begins clocking the satellite components including the SERDES using the crystal as a clock source and a frequency reference. After

the SERDES recovers the clock, the CDCE62005 removes the jitter via the on-chip synthesizer/loop filter. The recovered clock from the communications link becomes the frequency reference for the satellite system after the smart multiplexer automatically switches over to it. The CDCE62005 applies the cleaned clock to the recovered clock input on the SERDES, thereby establishing a reliable communications link between host and satellite systems.

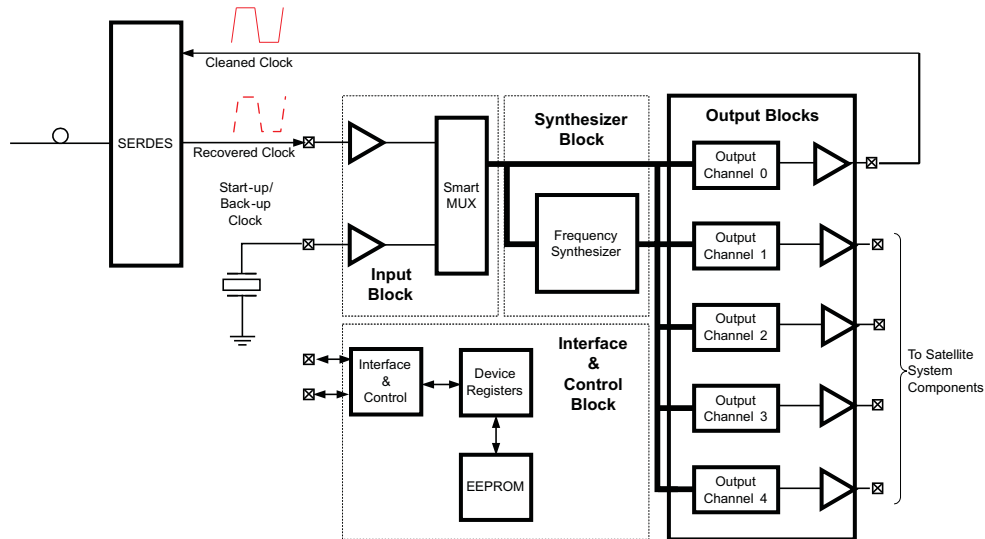

Figure 39. CDCE62005 SERDES Startup Mode

8.5 Programming

8.5.1 Interface and Control Block

The Interface and Control Block includes a SPI interface, three control pins, a non-volatile memory array in which the device stores default configuration data, and an array of device registers implemented in Static RAM. This RAM, also called the device registers, configures all hardware within the CDCE62005.

8.5.1.1 Serial Peripheral Interface (SPI)

The serial interface of CDCE62005 is a simple bidirectional SPI interface for writing and reading to and from the device registers. It implements a low speed serial communications link in a master/slave topology in which the CDCE62005 is a slave. The SPI consists of four signals:

SPI_CLK: Serial Clock (Output from Master)

The CDCE62005 clocks data in and out on the rising edge of SPI_CLK. Data transitions therefore occur on the falling edge of the clock.

SPI_MOSI: Master Output Slave Input (Output from Master)

SPI_MISO: Master Input Slave Output (Output from Slave)

SPI_LE: Latch Enable (Output from Master)

The falling edge of SPI_LE initiates a transfer. If SPI_LE is high, no data transfer can take place.

The CDCE62005 implements data fields that are 28-bits wide. In addition, it contains 9 registers, each comprising a 28 bit data field. Therefore, accessing the CDCE62005 requires that the host program append a 4-bit address field to the front of the data field as follows:

Programming (continued)

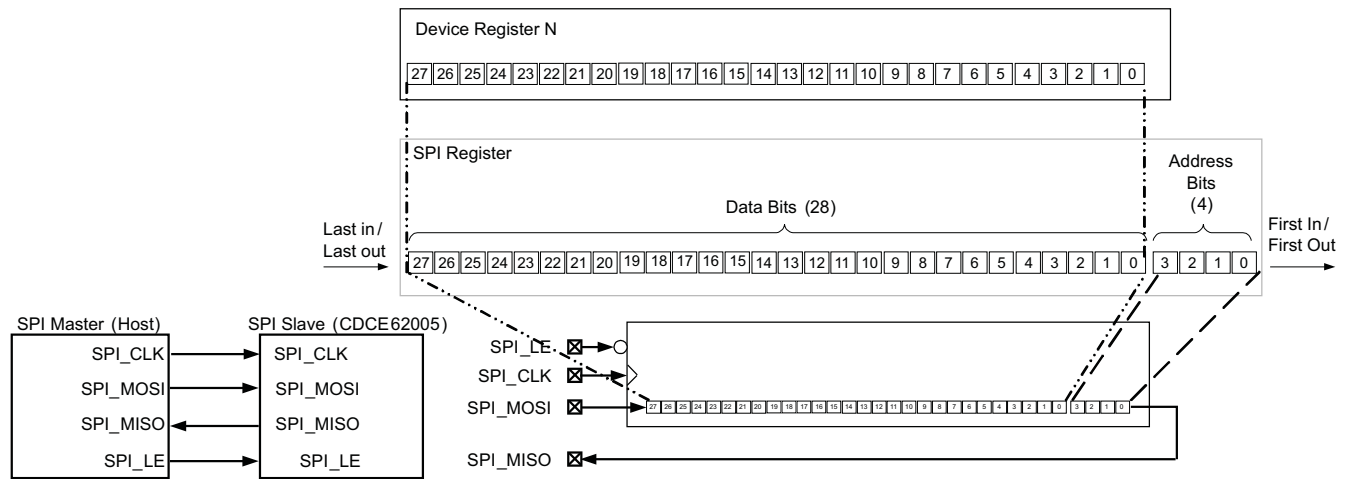

Figure 40. CDCE62005 SPI Communications Format

8.5.1.2 CDCE62005 SPI Command Structure

The CDCE62005 supports four commands issued by the Master via the SPI:

- Write to RAM
- Read Command
- Copy RAM to EEPROM – unlock
- Copy RAM to EEPROM – lock

Table 38 provides a summary of the CDCE62005 SPI command structure. The host (master) constructs a Write to RAM command by specifying the appropriate register address in the address field and appends this value to the beginning of the data field. Therefore, a valid command stream must include 32 bits, transmitted LSB first. The host must issue a Read Command to initiate a data transfer from the CDCE62005 back to the host. This command specifies the address of the register of interest in the data field.

The CDCE62005 on-board EEPROM has been factory preset to the default settings listed in [Table 39](#).

Table 39. Register and Default Setting

REGISTER	DEFAULT SETTING
REG0000	8184032
REG0001	8184030
REG0002	8186030
REG0003	EB86030
REG0004	0186031
REG0005	101C0BE
REG0006	04BE19A
REG0007	BD0037F

The Default configurations programmed in the device is set to: Primary and Secondary are set to LVPECL ac-coupled termination and the Auxiliary input is enabled. The Smart Mux is set to auto select among Primary, Secondary and Auxiliary. Reference is set at 25MHz and the dividers are selected to run the VCO at 1875MHz.

- Output 0 & 1 are set to output 156.25MHz with LVPECL signaling
- Output 2 is set to output 125MHz/ LVPECL
- Output 3 is set to output 125MHz/ LVDS
- Output 4 is set to output 125MHz/ LVCMO

8.5.1.3 SPI Interface Master

The Interface master can be designed using a FPGA or a micro controller. The CDCE62005 acts as a slave to the SPI master. The SPI Master should be designed to issue none consecutive read or write commands. The SPI clock should start and stop with respect to the SPI_LE signal as shown in [Figure 41](#). SPI_MOSI, SPI_CLK, and SPI_LE are generated by the SPI Master. SPI_MISO is generated by the SPI slave the CDCE62005.

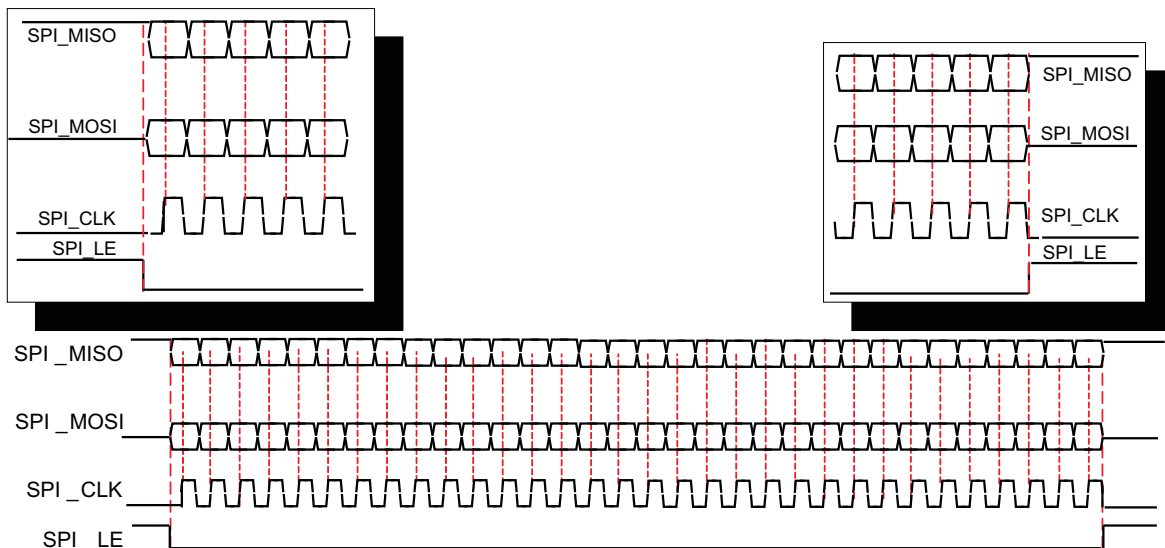

Figure 41. CDCE62005 SPI Read/Write Command

8.5.1.4 SPI Consecutive Read/Write Cycles to the CDCE62005

Figure 42 illustrates how two consecutive SPI cycles are performed between a SPI Master and the CDCE62005 SPI Slave.

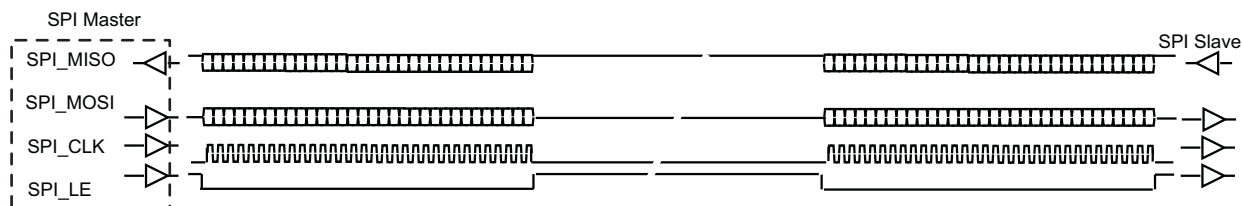

Figure 42. Consecutive Read/Write Cycles

8.5.1.5 Writing to the CDCE62005

Figure 43 illustrates a Write to RAM operation. Notice that the latching of the first data bit in the data stream (Bit 0) occurs on the first rising edge of SPI_CLK after SPI_LE transitions from a high to a low. For the CDCE62005, data transitions occur on the falling edge of SPI_CLK. A rising edge on SPI_LE signals to the CDCE62005 that the transmission of the last bit in the stream (Bit 31) has occurred.

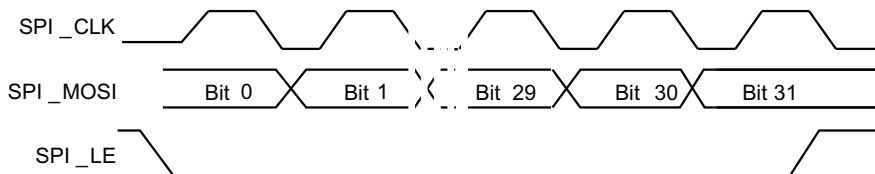

Figure 43. CDCE62005 SPI Write Operation

8.5.1.6 Reading from the CDCE62005

Figure 44 shows how the CDCE62005 executes a Read Command. The SPI master first issues a Read Command to initiate a data transfer from the CDCE62005 back to the host (see Table 40). This command specifies the address of the register of interest. By transitioning SPI_LE from a low to a high, the CDCE62005 resolves the address specified in the appropriate bits of the data field. The host drives SPI_LE low and the CDCE62005 presents the data present in the register specified in the Read Command on SPI_MISO.

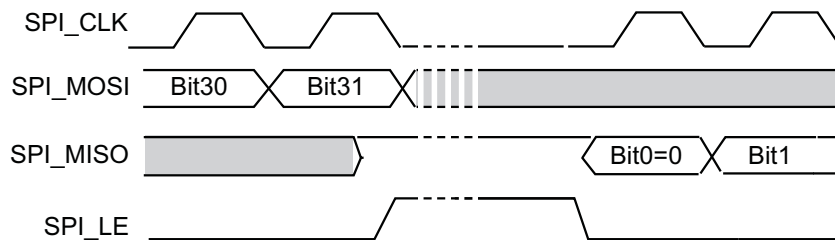

Figure 44. CDCE62005 Read Operation

8.5.1.7 Writing to EEPROM

After the CDCE62005 detects a power-up and completes a reset cycle, it copies the contents of the on-board EEPROM into the Device Registers. Therefore, the CDCE62005 initializes into a known state pre-defined by the user. The host issues one of two special commands shown in Table 38 to copy the contents of Device Registers 0 through 7 (a total of 184 bits) into EEPROM. They include:

- Copy RAM to EEPROM – Unlock, Execution of this command can happen many times.
- Copy RAM to EEPROM – Lock: Execution of this command can happen only once, after which the EEPROM is permanently locked.

After either command is initiated, power must remain stable and the host must not access the CDCE62005 for at least 50 ms to allow the EEPROM to complete the write cycle and to avoid the possibility of EEPROM corruption.

8.5.2 Device Configuration

The Functional Description Section described four different functional blocks contained within the CDCE62005. Figure 45 depicts these blocks along with a high-level functional block diagram of the circuit elements comprising each block. The balance of this section focuses on a detailed discussion of each functional block from the perspective of how to configure them.

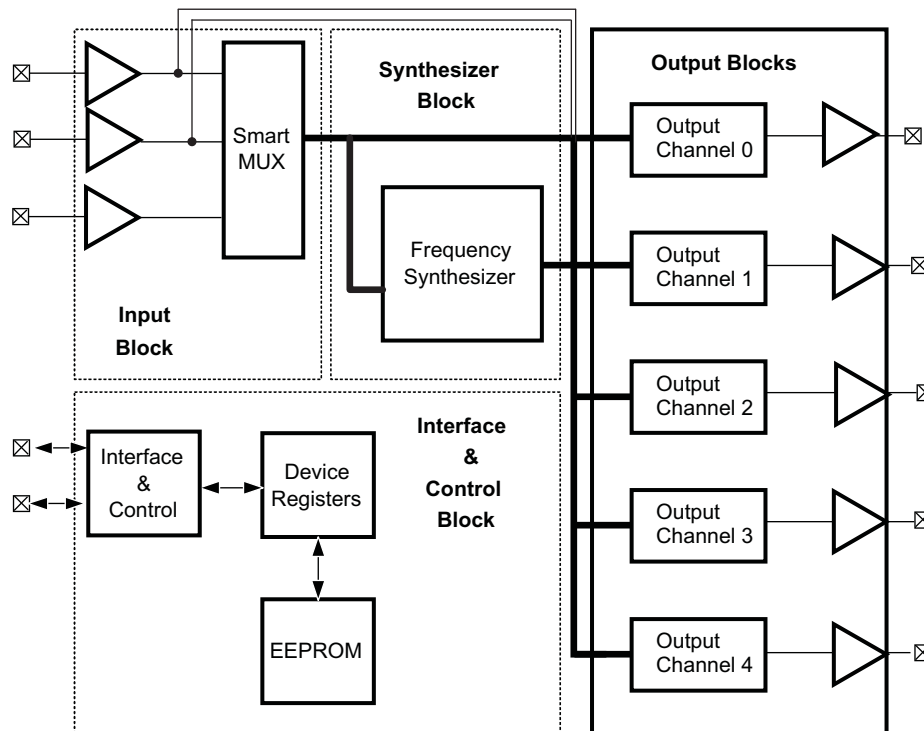

Figure 45. CDCE62005 Circuit Blocks

Throughout this section, references to Device Register memory locations follow the following convention:

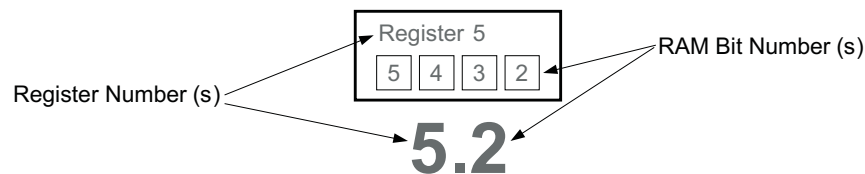

Figure 46. Device Register Reference Convention

8.6 Register Maps

8.6.1 Device Registers: Register 0 Address 0x00

Table 40. CDCE62005 Register 0 Bit Definitions

RAM BIT	BIT NAME	RELATED BLOCK	DESCRIPTION/FUNCTION																																											
0	DIV2PRIX	Primary Reference	Pre-Divider Selection for the Primary Reference (X,Y)=00:3-state, 01:Divide by 1, 10:Divide by 2, 11:Reserved		EEPROM																																									
1	DIV2PRIY		EEPROM																																											
2	RESERVED		Must be set to 0		EEPROM																																									
3	RESERVED		Must be set to 0		EEPROM																																									
4	OUTMUX0SELX	Output 0	OUTPUT MUX 0 Select. Selects the Signal driving Output Divider 0 (X,Y) = 00: PRL_REF, 01:SEC_REF, 10:SMART_MUX, 11:VCO_CORE		EEPROM																																									
5	OUTMUX0SELY	Output 0			EEPROM																																									
6	PH0ADJC0	Output 0	Coarse phase adjust select for output divider 0		EEPROM																																									
7	PH0ADJC1	Output 0			EEPROM																																									
8	PH0ADJC2	Output 0			EEPROM																																									
9	PH0ADJC3	Output 0			EEPROM																																									
10	PH0ADJC4	Output 0			EEPROM																																									
11	PH0ADJC5	Output 0			EEPROM																																									
12	PH0ADJC6	Output 0			EEPROM																																									
13	OUT0DIVRSEL0	Output 0	OUTPUT DIVIDER 0 Ratio Select		EEPROM																																									
14	OUT0DIVRSEL1	Output 0			EEPROM																																									
15	OUT0DIVRSEL2	Output 0			EEPROM																																									
16	OUT0DIVRSEL3	Output 0			EEPROM																																									
17	OUT0DIVRSEL4	Output 0			EEPROM																																									
18	OUT0DIVRSEL5	Output 0			EEPROM																																									
19	OUT0DIVRSEL6	Output 0			EEPROM																																									
20	OUT0DIVSEL	Output 0	When set to 0, the divider is disabled. When set to 1, the divider is enabled.		EEPROM																																									
21	HISWINGLVPECL0	Output 0	High Swing LVPECL. When set to 1 and Normal Swing when set to 0. – If LVCMOS or LVDS is selected the Output swing will stay at the same level. ⁽¹⁾ – If LVPECL buffer is selected the Output Swing will be 30% higher if this bit is set to 1 and Normal LVPECL if it is set to 0.		EEPROM																																									
22	CMOSMODE0PX	Output 0	LVCMOS mode select for OUTPUT 0 Positive Pin. (X,Y)=00:Active, 10:Inverting, 11:Low, 01:3-State		EEPROM																																									
23	CMOSMODE0PY	Output 0			EEPROM																																									
24	CMOSMODE0NX	Output 0	LVCMOS mode select for OUTPUT 0 Negative Pin. (X,Y)=00:Active, 10:Inverting, 11:Low, 01:3-State		EEPROM																																									
25	CMOSMODE0NY	Output 0			EEPROM																																									
26	OUTBUFSEL0X	Output 0	<table border="1"> <thead> <tr> <th rowspan="2">OUTPUT TYPE</th> <th colspan="6">RAM BITS</th> </tr> <tr> <th>22</th> <th>23</th> <th>24</th> <th>25</th> <th>26</th> <th>27</th> </tr> </thead> <tbody> <tr> <td>LVPECL</td> <td>0</td> <td>0</td> <td>0</td> <td>0</td> <td>0</td> <td>1</td> </tr> <tr> <td>LVDS</td> <td>0</td> <td>1</td> <td>0</td> <td>1</td> <td>1</td> <td>1</td> </tr> <tr> <td>LVCMOS</td> <td colspan="4">See Settings Above</td> <td>0</td> <td>0</td> </tr> <tr> <td>Output Disabled</td> <td>0</td> <td>1</td> <td>0</td> <td>1</td> <td>1</td> <td>0</td> </tr> </tbody> </table>		OUTPUT TYPE	RAM BITS						22	23	24	25	26	27	LVPECL	0	0	0	0	0	1	LVDS	0	1	0	1	1	1	LVCMOS	See Settings Above				0	0	Output Disabled	0	1	0	1	1	0	EEPROM
OUTPUT TYPE	RAM BITS																																													
	22	23			24	25	26	27																																						
LVPECL	0	0			0	0	0	1																																						
LVDS	0	1			0	1	1	1																																						
LVCMOS	See Settings Above				0	0																																								
Output Disabled	0	1	0	1	1	0																																								
27	OUTBUFSEL0Y	Output 0			EEPROM																																									

* Use Description for Bits 22,23,24 and 25 for setting the LVCMOS Outputs

(1) Set RegisterR0.21 to 0 for LVDS and LVCMOS outputs

8.6.2 Device Registers: Register 1 Address 0x01

Table 41. CDCE62005 Register 1 Bit Definitions

RAM BIT	BIT NAME	RELATED BLOCK	DESCRIPTION/FUNCTION																																										
0	DIV2SECX	Secondary Reference	Pre-Divider Selection for the Secondary Reference (X,Y)=00:3-state, 01:Divide by 1, 10:Divide by 2, 11:Reserved	EEPROM																																									
1	DIV2SECY			EEPROM																																									
2	RESERVED		Must be set to 0	EEPROM																																									
3	RESERVED		Must be set to 0	EEPROM																																									
4	OUTMUX1SELX	Output 1	OUTPUT MUX 1 Select. Selects the Signal driving Output Divider 1. (X,Y) = 00: PRI_REF, 01:SEC_REF, 10:SMART_MUX, 11:VCO_CORE	EEPROM																																									
5	OUTMUX1SELY	Output 1		EEPROM																																									
6	PH1ADJC0	Output 1	Coarse phase adjust select for output divider 1	EEPROM																																									
7	PH1ADJC1	Output 1		EEPROM																																									
8	PH1ADJC2	Output 1		EEPROM																																									
9	PH1ADJC3	Output 1		EEPROM																																									
10	PH1ADJC4	Output 1		EEPROM																																									
11	PH1ADJC5	Output 1		EEPROM																																									
12	PH1ADJC6	Output 1		EEPROM																																									
13	OUT1DIVRSEL0	Output 1	OUTPUT DIVIDER 1 Ratio Select	EEPROM																																									
14	OUT1DIVRSEL1	Output 1		EEPROM																																									
15	OUT1DIVRSEL2	Output 1		EEPROM																																									
16	OUT1DIVRSEL3	Output 1		EEPROM																																									
17	OUT1DIVRSEL4	Output 1		EEPROM																																									
18	OUT1DIVRSEL5	Output 1		EEPROM																																									
19	OUT1DIVRSEL6	Output 1		EEPROM																																									
20	OUT1DIVSEL	Output 1	When set to 0, the divider is disabled When set to 1, the divider is enabled	EEPROM																																									
21	HiSWINGLVPECL1	Output 1	High Swing LVPECL When set to 1 and Normal Swing when set to 0 – If LVCMOS or LVDS is selected the Output swing will stay at the same level. ⁽¹⁾ – If LVPECL buffer is selected the Output Swing will be 30% higher if this bit is set to 1 and Normal LVPECL if it is set to 0.	EEPROM																																									
22	CMOSMODE1PX	Output 1	LVCMOS mode select for OUTPUT 1 Positive Pin. (X,Y)=00:Active, 10:Inverting, 11:Low, 01:3-State	EEPROM																																									
23	CMOSMODE1PY	Output 1		EEPROM																																									
24	CMOSMODE1NX	Output 1	LVCMOS mode select for OUTPUT 1 Negative Pin. (X,Y)=00:Active, 10:Inverting, 11:Low, 01:3-State	EEPROM																																									
25	CMOSMODE1NY	Output 1		EEPROM																																									
26	OUTBUFSEL1X	Output 1	<table border="1"> <thead> <tr> <th rowspan="2">OUTPUT TYPE</th> <th colspan="6">RAM BITS</th> </tr> <tr> <th>22</th> <th>23</th> <th>24</th> <th>25</th> <th>26</th> <th>27</th> </tr> </thead> <tbody> <tr> <td>LVPECL</td> <td>0</td> <td>0</td> <td>0</td> <td>0</td> <td>0</td> <td>1</td> </tr> <tr> <td>LVDS</td> <td>0</td> <td>1</td> <td>0</td> <td>1</td> <td>1</td> <td>1</td> </tr> <tr> <td>LVCMOS</td> <td colspan="4">See Settings Above*</td> <td>0</td> <td>0</td> </tr> <tr> <td>Output Disabled</td> <td>0</td> <td>1</td> <td>0</td> <td>1</td> <td>1</td> <td>0</td> </tr> </tbody> </table>	OUTPUT TYPE	RAM BITS						22	23	24	25	26	27	LVPECL	0	0	0	0	0	1	LVDS	0	1	0	1	1	1	LVCMOS	See Settings Above*				0	0	Output Disabled	0	1	0	1	1	0	EEPROM
OUTPUT TYPE	RAM BITS																																												
	22	23		24	25	26	27																																						
LVPECL	0	0		0	0	0	1																																						
LVDS	0	1		0	1	1	1																																						
LVCMOS	See Settings Above*				0	0																																							
Output Disabled	0	1	0	1	1	0																																							
27	OUTBUFSEL1Y	Output 1		EEPROM																																									

* Use Description for Bits 22,23,24 and 25 for setting the LVCMOS Outputs

(1) Set the R1.21 to 0 for LVDS and LVCMOS outputs

8.6.3 Device Registers: Register 2 Address 0x02
Table 42. CDCE62005 Register 2 Bit Definitions

RAM BIT	BIT NAME	RELATED BLOCK	DESCRIPTION/FUNCTION																																										
0	REFDIV0	Reference Divider	Reference Divider Bit 0	EEPROM																																									
1	REFDIV1		Reference Divider Bit 1	EEPROM																																									
2	RESERVED		Must be set to 0	EEPROM																																									
3	RESERVED		Must be set to 0	EEPROM																																									
4	OUTMUX2SELX	Output 2	OUTPUT MUX 2 Select. Selects the Signal driving Output Divider 2 (X,Y) = 00: PRI_REF, 01: SEC_REF, 10: SMART_MUX, 11: VCO_CORE	EEPROM																																									
5	OUTMUX2SELY	Output 2		EEPROM																																									
6	PH2ADJC0	Output 2	Coarse phase adjust select for output divider 2	EEPROM																																									
7	PH2ADJC1	Output 2		EEPROM																																									
8	PH2ADJC2	Output 2		EEPROM																																									
9	PH2ADJC3	Output 2		EEPROM																																									
10	PH2ADJC4	Output 2		EEPROM																																									
11	PH2ADJC5	Output 2		EEPROM																																									
12	PH2ADJC6	Output 2		EEPROM																																									
13	OUT2DIVRSEL0	Output 2	OUTPUT DIVIDER 2 Ratio Select	EEPROM																																									
14	OUT2DIVRSEL1	Output 2		EEPROM																																									
15	OUT2DIVRSEL2	Output 2		EEPROM																																									
16	OUT2DIVRSEL3	Output 2		EEPROM																																									
17	OUT2DIVRSEL4	Output 2		EEPROM																																									
18	OUT2DIVRSEL5	Output 2		EEPROM																																									
19	OUT2DIVRSEL6	Output 2		EEPROM																																									
20	OUT2DIVSEL	Output 2	When set to 0, the divider is disabled When set to 1, the divider is enabled	EEPROM																																									
21	HiSWINGLVPECL	Output 2	High Swing LVPECL. When set to 1 and Normal Swing when set to 0. – If LVCMOS or LVDS is selected the Output swing will stay at the same level. ⁽¹⁾ – If LVPECL buffer is selected the Output Swing will be 30% higher if this bit is set to 1 and Normal LVPECL if it is set to 0.	EEPROM																																									
22	CMOSMODE2PX	Output 2	LVCMOS mode select for OUTPUT 2 Positive Pin. (X,Y)=00:Active, 10:Inverting, 11:Low, 01:3-State	EEPROM																																									
23	CMOSMODE2PY	Output 2		EEPROM																																									
24	CMOSMODE2NX	Output 2	LVCMOS mode select for OUTPUT 2 Negative Pin. (X,Y)=00:Active, 10:Inverting, 11:Low, 01:3-State	EEPROM																																									
25	CMOSMODE2NY	Output 2		EEPROM																																									
26	OUTBUFSEL2X	Output 2	<table border="1"> <thead> <tr> <th rowspan="2">OUTPUT TYPE</th> <th colspan="6">RAM BITS</th> </tr> <tr> <th>22</th> <th>23</th> <th>24</th> <th>25</th> <th>26</th> <th>27</th> </tr> </thead> <tbody> <tr> <td>LVPECL</td> <td>0</td> <td>0</td> <td>0</td> <td>0</td> <td>0</td> <td>1</td> </tr> <tr> <td>LVDS</td> <td>0</td> <td>1</td> <td>0</td> <td>1</td> <td>1</td> <td>1</td> </tr> <tr> <td>LVCMOS</td> <td colspan="4">See Settings Above</td> <td>0</td> <td>0</td> </tr> <tr> <td>Output Disabled</td> <td>0</td> <td>1</td> <td>0</td> <td>1</td> <td>1</td> <td>0</td> </tr> </tbody> </table>	OUTPUT TYPE	RAM BITS						22	23	24	25	26	27	LVPECL	0	0	0	0	0	1	LVDS	0	1	0	1	1	1	LVCMOS	See Settings Above				0	0	Output Disabled	0	1	0	1	1	0	EEPROM
OUTPUT TYPE	RAM BITS																																												
	22	23		24	25	26	27																																						
LVPECL	0	0		0	0	0	1																																						
LVDS	0	1		0	1	1	1																																						
LVCMOS	See Settings Above				0	0																																							
Output Disabled	0	1	0	1	1	0																																							
27	OUTBUFSEL2Y	Output 2		EEPROM																																									

* Use Description for Bits 22,23,24 and 25 for setting the LVCMOS Outputs

(1) Set the R2.21 to 0 for LVDS and LVCMOS outputs

8.6.4 Device Registers: Register 3 Address 0x03

Table 43. CDCE62005 Register 3 Bit Definitions

RAM BIT	BIT NAME	RELATED BLOCK	DESCRIPTION/FUNCTION																																										
0	REFDIV2	Reference Divider	Reference Divider Bit 2.	EEPROM																																									
1	RESERVED		Must be set to 0.	EEPROM																																									
2	RESERVED		Must be set to 0.	EEPROM																																									
3	RESERVED		Must be set to 0.	EEPROM																																									
4	OUTMUX3SELX	Output 3	OUTPUT MUX 3 Select. Selects the Signal driving Output Divider 3. (X,Y) = 00: PRL_REF, 01:SEC_REF, 10:SMART_MUX, 11:VCO_CORE	EEPROM																																									
5	OUTMUX3SELY	Output 3		EEPROM																																									
6	PH3ADJC0	Output 3	Coarse phase adjust select for output divider 3	EEPROM																																									
7	PH3ADJC1	Output 3		EEPROM																																									
8	PH3ADJC2	Output 3		EEPROM																																									
9	PH3ADJC3	Output 3		EEPROM																																									
10	PH3ADJC4	Output 3		EEPROM																																									
11	PH3ADJC5	Output 3		EEPROM																																									
12	PH3ADJC6	Output 3		EEPROM																																									
13	OUT3DIVRSEL0	Output 3	OUTPUT DIVIDER 3 Ratio Select	EEPROM																																									
14	OUT3DIVRSEL1	Output 3		EEPROM																																									
15	OUT3DIVRSEL2	Output 3		EEPROM																																									
16	OUT3DIVRSEL3	Output 3		EEPROM																																									
17	OUT3DIVRSEL4	Output 3		EEPROM																																									
18	OUT3DIVRSEL5	Output 3		EEPROM																																									
19	OUT3DIVRSEL6	Output 3		EEPROM																																									
20	OUT3DIVSEL	Output 3	When set to 0, the divider is disabled When set to 1, the divider is enabled	EEPROM																																									
21	HiSWINGLVPECL3	Output 3	High Swing LVPECL When set to 1 and Normal Swing when set to 0. – If LVCMOS or LVDS is selected the Output swing will stay at the same level. ⁽¹⁾ – If LVPECL buffer is selected the Output Swing will be 30% higher if this bit is set to 1 and Normal LVPECL if it is set to 0.	EEPROM																																									
22	CMOSMODE3PX	Output 3	LVCMOS mode select for OUTPUT 3 Positive Pin. (X,Y)=00:Active, 10:Inverting, 11:Low, 01:3-State	EEPROM																																									
23	CMOSMODE3PY	Output 3		EEPROM																																									
24	CMOSMODE3NX	Output 3	LVCMOS mode select for OUTPUT 3 Negative Pin. (X,Y)=00:Active, 10:Inverting, 11:Low, 01:3-State	EEPROM																																									
25	CMOSMODE3NY	Output 3		EEPROM																																									
26	OUTBUFSEL3X	Output 3	<table border="1"> <thead> <tr> <th rowspan="2">OUTPUT TYPE</th> <th colspan="6">RAM BITS</th> </tr> <tr> <th>22</th> <th>23</th> <th>24</th> <th>25</th> <th>26</th> <th>27</th> </tr> </thead> <tbody> <tr> <td>LVPECL</td> <td>0</td> <td>0</td> <td>0</td> <td>0</td> <td>0</td> <td>1</td> </tr> <tr> <td>LVDS</td> <td>0</td> <td>1</td> <td>0</td> <td>1</td> <td>1</td> <td>1</td> </tr> <tr> <td>LVCMOS</td> <td colspan="4">See Settings Above*</td> <td>0</td> <td>0</td> </tr> <tr> <td>Output Disabled</td> <td>0</td> <td>1</td> <td>0</td> <td>1</td> <td>1</td> <td>0</td> </tr> </tbody> </table>	OUTPUT TYPE	RAM BITS						22	23	24	25	26	27	LVPECL	0	0	0	0	0	1	LVDS	0	1	0	1	1	1	LVCMOS	See Settings Above*				0	0	Output Disabled	0	1	0	1	1	0	EEPROM
OUTPUT TYPE	RAM BITS																																												
	22	23		24	25	26	27																																						
LVPECL	0	0		0	0	0	1																																						
LVDS	0	1		0	1	1	1																																						
LVCMOS	See Settings Above*				0	0																																							
Output Disabled	0	1	0	1	1	0																																							
27	OUTBUFSEL3Y	Output 3		EEPROM																																									

* Use Description for Bits 22,23,24 and 25 for setting the LVCMOS Outputs

(1) Set the R3.21 to 0 for LVDS and LVCMOS outputs

8.6.5 Device Registers: Register 4 Address 0x04
Table 44. CDCE62005 Register 4 Bit Definitions

RAM BIT	BIT NAME	RELATED BLOCK	DESCRIPTION/FUNCTION																																										
0	RESERVED	—	This bit must be set to a 1	EEPROM																																									
1	SYNC_MODE1	Outputs	0 (default): Outputs have deterministic delay relative to low-to-high pulse of SYNC pin when the EEPROM SYNC signal is synchronized with the reference input and added 6µs delay. 1: outputs have deterministic delay relative to low-to-high pulse of SYNC pin when the SYNC signal is synchronized with the reference input	EEPROM																																									
2	RESERVED		Must be set to 0	EEPROM																																									
3	RESERVED		Must be set to 0	EEPROM																																									
4	OUTMUX4SELX	Output 4	OUTPUT MUX 4 Select. Selects the Signal driving Output Divider 4 (X,Y) = 00: PRI_REF, 01:SEC_REF, 10:SMART_MUX, 11:VCO_CORE	EEPROM																																									
5	OUTMUX4SELY	Output 4		EEPROM																																									
6	PH4ADJC0	Output 4	Coarse phase adjust select for output divider 4	EEPROM																																									
7	PH4ADJC1	Output 4		EEPROM																																									
8	PH4ADJC2	Output 4		EEPROM																																									
9	PH4ADJC3	Output 4		EEPROM																																									
10	PH4ADJC4	Output 4		EEPROM																																									
11	PH4ADJC5	Output 4		EEPROM																																									
12	PH4ADJC6	Output 4		EEPROM																																									
13	OUT4DIVRSEL0	Output 4	OUTPUT DIVIDER 4 Ratio Select	EEPROM																																									
14	OUT4DIVRSEL1	Output 4		EEPROM																																									
15	OUT4DIVRSEL2	Output 4		EEPROM																																									
16	OUT4DIVRSEL3	Output 4		EEPROM																																									
17	OUT4DIVRSEL4	Output 4		EEPROM																																									
18	OUT4DIVRSEL5	Output 4		EEPROM																																									
19	OUT4DIVRSEL6	Output 4		EEPROM																																									
20	OUT4DIVSEL	Output 4	When set to 0, the divider is disabled When set to 1, the divider is enabled	EEPROM																																									
21	HiSWINGLVPECL4	Output 4	High Swing LVPECL When set to 1 and Normal Swing when set to 0. – If LVCMOS or LVDS is selected the Output swing will stay at the same level. ⁽¹⁾ – If LVPECL buffer is selected the Output Swing will be 30% higher if this bit is set to 1 and Normal LVPECL if it is set to 0.	EEPROM																																									
22	CMOSMODE4PX	Output 4	LVCMOS mode select for OUTPUT 4 Positive Pin. (X,Y)=00:Active, 10:Inverting, 11:Low, 01:3-State	EEPROM																																									
23	CMOSMODE4PY	Output 4		EEPROM																																									
24	CMOSMODE4NX	Output 4	LVCMOS mode select for OUTPUT 3 Negative Pin. (X,Y)=00:Active, 10:Inverting, 11:Low, 01:3-State	EEPROM																																									
25	CMOSMODE4NY	Output 4		EEPROM																																									
26	OUTBUFSEL4X	Output 4	<table border="1"> <thead> <tr> <th rowspan="2">OUTPUT TYPE</th> <th colspan="6">RAM BITS</th> </tr> <tr> <th>22</th> <th>23</th> <th>24</th> <th>25</th> <th>26</th> <th>27</th> </tr> </thead> <tbody> <tr> <td>LVPECL</td> <td>0</td> <td>0</td> <td>0</td> <td>0</td> <td>0</td> <td>1</td> </tr> <tr> <td>LVDS</td> <td>0</td> <td>1</td> <td>0</td> <td>1</td> <td>1</td> <td>1</td> </tr> <tr> <td>LVCMOS</td> <td colspan="4">See Settings Above*</td> <td>0</td> <td>0</td> </tr> <tr> <td>Output Disabled</td> <td>0</td> <td>1</td> <td>0</td> <td>1</td> <td>1</td> <td>0</td> </tr> </tbody> </table>	OUTPUT TYPE	RAM BITS						22	23	24	25	26	27	LVPECL	0	0	0	0	0	1	LVDS	0	1	0	1	1	1	LVCMOS	See Settings Above*				0	0	Output Disabled	0	1	0	1	1	0	EEPROM
OUTPUT TYPE	RAM BITS																																												
	22	23		24	25	26	27																																						
LVPECL	0	0		0	0	0	1																																						
LVDS	0	1		0	1	1	1																																						
LVCMOS	See Settings Above*				0	0																																							
Output Disabled	0	1	0	1	1	0																																							
27	OUTBUFSEL4Y	Output 4		EEPROM																																									

* Use Description for Bits 22,23,24 and 25 for setting the LVCMOS Outputs

(1) Set the R4.21 0 for LVDS and LVCMOS outputs

8.6.6 Device Registers: Register 5 Address 0x05

Table 45. CDCE62005 Register 5 Bit Definitions

RAM BIT	BIT NAME	RELATED BLOCK	DESCRIPTION/FUNCTION	
0	INBUFSELX	INBUFSELX	Input Buffer Select (LVPECL, LVDS or LVCMOS)	EEPROM
1	INBUFESELY	INBUFESELY	Reg5[1:0]=00=LVCMOS Reg5[1:0]=01=reserved Reg5[1:0]=10=LVPECL Reg5[1:0]=11=LVDS	EEPROM
2	PRISEL	Smart MUX	When EECLKSEL = 1; Bit (2,3,4) 100 – PRISEL, 010 – SECSEL, 001 – AUXSEL 110 – Auto Select (PRI then SEC) 111 – Auto Select (PRI then SEC and then AUX) When EECLKSEL = 0, REF_SEL pin determines the Reference Input to the Smart Mux circuitry.	EEPROM
3	SECSEL			EEPROM
4	AUXSEL ⁽¹⁾			EEPROM
5	EECLKSEL	Smart MUX	If EEPROM Clock Select Input is set to 1 The Clock selections follows internal EEPROM settings and ignores REF_SEL Pin status, when Set to 0 REF_SEL is used to control the Mux, Auto Select Function is not available and AUXSEL is not available.	EEPROM
6	ACDCSEL	Input Buffers	If set to 1 DC Termination, If set to 0 AC Termination	EEPROM
7	HYSTEN	Input Buffers	If set to 1 Input Buffers Hysteresis Enabled. It is not recommended that Hysteresis be disabled.	EEPROM
8	PRI_TERMSEL	Input Buffers	If set to 0 Primary Input Buffer Internal Termination Enabled If set to 1 Primary Internal Termination circuitry Disabled	EEPROM
9	PRIINVBB	Input Buffers	If set to 0 Primary Input Negative Pin Biased with Internal VBB Voltage.	EEPROM
10	SECINVBB	Input Buffers	If set to 0 Secondary Input Negative Pin Biased with Internal VBB Voltage	EEPROM
11	FAILSAFE	Input Buffers	If set to 1 Fail Safe is Enabled for all Input Buffers configured as LVDS, DC Coupling only.	EEPROM
12	RESERVED		Must be set to 0	EEPROM
13	RESERVED		Must be set to 0	EEPROM
14	SELINDIV0	VCO Core	INPUT DIVIDER Settings	EEPROM
15	SELINDIV1	VCO Core		EEPROM
16	SELINDIV2	VCO Core		EEPROM
17	SELINDIV3	VCO Core		EEPROM
18	SELINDIV4	VCO Core		EEPROM
19	SELINDIV5	VCO Core		EEPROM
20	SELINDIV6	VCO Core		EEPROM
21	SELINDIV7	VCO Core		EEPROM
22	LOCKW(0)	PLL Lock	See Table 34	EEPROM
23	LOCKW(1)			EEPROM
24	LOCKW(2)			EEPROM
25	LOCKW(3)			EEPROM
26	LOCKDET	PLL Lock	Number of coherent lock events. If set to 0 it triggers after the first lock detection if set to 1 it triggers lock after 64 PFD cycles of lock detections.	EEPROM
27	ADLOCK	PLL Lock	Selects Digital PLL_LOCK 0, Selects Analog PLL_LOCK 1	EEPROM

(1) If the AUXSEL bit is set to 1, a crystal must be connected to the AUXIN input properly (see the Crystal Input Interface section).

8.6.7 Device Registers: Register 6 Address 0x06
Table 46. CDCE62005 Register 6 Bit Definitions

RAM BIT	BIT NAME	RELATED BLOCK	DESCRIPTION/FUNCTION	
0	SELVCO	VCO Core	VCO Select, 0:VCO1(low range), 1:VCO2(high range)	EEPROM
1	SELPRESCA	VCO Core	PRESCALER Setting.	EEPROM
2	SELPRESCB	VCO Core		EEPROM
3	SELFBDIV0	VCO Core		FEEDBACK DIVIDER Setting
4	SELFBDIV1	VCO Core	EEPROM	
5	SELFBDIV2	VCO Core	EEPROM	
6	SELFBDIV3	VCO Core	EEPROM	
7	SELFBDIV4	VCO Core	EEPROM	
8	SELFBDIV5	VCO Core	EEPROM	
9	SELFBDIV6	VCO Core	EEPROM	
10	SELFBDIV7	VCO Core	EEPROM	
11	RESERVED		Must be set to 0	EEPROM
12	SEC_TERMSEL	Input Buffers	If Set to Secondary Input Buffer Internal Termination Enabled If set to 1 Secondary Internal Termination circuitry Disabled	EEPROM
13	SELBPDIV0	VCO Core	BYPASS DIVIDER Setting (6 settings + Disable + Enable)	EEPROM
14	SELBPDIV1	VCO Core		EEPROM
15	SELBPDIV2	VCO Core		EEPROM
16	ICPSEL0	VCO Core	CHARGE PUMP Current Select (see Table 27)	EEPROM
17	ICPSEL1	VCO Core		EEPROM
18	ICPSEL2	VCO Core		EEPROM
19	ICPSEL3	VCO Core		EEPROM
20	SYNC_MODE2	VCO Core	When set to 0, outputs are synchronized to the reference input on the low-to-high pulse on SYNC pin or bit. When set to 1, outputs are synchronized to the SYNC low-to-high pulse	EEPROM
21	CPPULSEWIDTH	VCO Core	If set to 1=wide pulse, 0=narrow pulse	EEPROM
22	ENCAL	VCO Core	Enable VCO Calibration Command. To execute this command a rising edge must be generated (that is, Write a LOW followed by a high to this bit location). This will initiate a VCO calibration sequence only if Calibration Mode = Manual Mode (that is, Register 6 bit 27 is HIGH).	EEPROM
23	RESERVED		Must be set to 0	EEPROM
24	AUXOUTEN	Output AUX	Enable Auxiliary Output when set to 1.	EEPROM
25	AUXFEEDSEL	Output AUX	Select the Output that will driving the AUX Output; Low for Selecting Output Divider 2 and High for Selecting Output Divider 3	EEPROM
26	EXLFSSEL	VCO Core	When Set to 1 External Loop filter is used. When Set to 0 Internal Loop Filter is used.	EEPROM
27	ENCAL_MODE	PLL Calibration	1: Calibration Mode = Manual Mode. In this mode, a calibration will be initiated if a rising edge is asserted on ENCAL (Register 6 Bit 22). 0: Calibration Mode = Startup Mode.	EEPROM

8.6.8 Device Registers: Register 7 Address 0x07

Table 47. CDCE62005 Register 7 Bit Definitions

RAM BIT	BIT NAME	RELATED BLOCK	DESCRIPTION/FUNCTION	
0	LFRCSEL0	VCO Core	Loop Filter Control Setting	EEPROM
1	LFRCSEL1	VCO Core	Loop Filter Control Setting	EEPROM
2	LFRCSEL2	VCO Core	Loop Filter Control Setting	EEPROM
3	LFRCSEL3	VCO Core	Loop Filter Control Setting	EEPROM
4	LFRCSEL4	VCO Core	Loop Filter Control Setting	EEPROM
5	LFRCSEL5	VCO Core	Loop Filter Control Setting	EEPROM
6	LFRCSEL6	VCO Core	Loop Filter Control Setting	EEPROM
7	LFRCSEL7	VCO Core	Loop Filter Control Setting	EEPROM
8	LFRCSEL8	VCO Core	Loop Filter Control Setting	EEPROM
9	LFRCSEL9	VCO Core	Loop Filter Control Setting	EEPROM
10	LFRCSEL10	VCO Core	Loop Filter Control Setting	EEPROM
11	LFRCSEL11	VCO Core	Loop Filter Control Setting	EEPROM
12	LFRCSEL12	VCO Core	Loop Filter Control Setting	EEPROM
13	LFRCSEL13	VCO Core	Loop Filter Control Setting	EEPROM
14	LFRCSEL14	VCO Core	Loop Filter Control Setting	EEPROM
15	LFRCSEL15	VCO Core	Loop Filter Control Setting	EEPROM
16	LFRCSEL16	VCO Core	Loop Filter Control Setting	EEPROM
17	LFRCSEL17	VCO Core	Loop Filter Control Setting	EEPROM
18	LFRCSEL18	VCO Core	Loop Filter Control Setting	EEPROM
19	LFRCSEL19	VCO Core	Loop Filter Control Setting	EEPROM
20	LFRCSEL20	VCO Core	Loop Filter Control Setting	EEPROM
21	RESERVED		Must be set to 0	EEPROM
22	RESERVED		Must be set to 1	EEPROM
23	SEL_DEL2	Smart Mux	If set to 0, it enables short delay for fast operation If Set to 1, Long Delay recommended for Input References below 150 MHz.	EEPROM
24	RESERVED		Must be set to 1	EEPROM
25	SEL_DEL1	Smart Mux	If set to 0, it enables short delay for fast operation If Set to 1, Long Delay recommended for Input References below 150 MHz.	EEPROM
26	EPLOCK	Status	Read Only If EPLOCK reads 0 EEPROM is unlocked. If EPLOCK reads 1, then the EEPROM is locked (see Table 38 for how to lock the EEPROM – this can only be executed once after which the EEPROM is locked permanently).	EEPROM
27	RESERVED	Status	Read Only; Always reads 1.	EEPROM

8.6.9 Device Registers: Register 8 Address 0x08
Table 48. CDCE62005 Register 8 Bit Definitions

RAM BIT	BIT NAME	RELATED BLOCK	DESCRIPTION/FUNCTION	
0	CALWORD0	Status	VCO Calibration Word read back from device (Read only)	RAM
1	CALWORD1	Status		RAM
2	CALWORD2	Status		RAM
3	CALWORD3	Status		RAM
4	CALWORD4	Status		RAM
5	CALWORD5	Status		RAM
6	PLLLOCKPIN	Status	Read Only: Status of the PLL Lock Pin Driven by the device.	RAM
7	SLEEP	Control	Set Device Sleep mode On when set to 0, Normal Mode when set to 1	RAM
8	SYNC	Control	If set to 0 this bit forces /SYNC; Set to 1 to exit the Synchronization State.	RAM
9	RESERVED		Must be set to 0	RAM
10	VERSION0		Read only	RAM
11	VERSION1		Read only	RAM
12	VERSION2		Read only	RAM
13	RESERVED		Must be set to 0	RAM
14	CALWORD_IN0	Diagnostics	<i>TI Test Registers. For TI Use Only (Must be set to 0)</i>	RAM
15	CALWORD_IN1	Diagnostics		RAM
16	CALWORD_IN2	Diagnostics		RAM
17	CALWORD_IN3	Diagnostics		RAM
18	CALWORD_IN4	Diagnostics		RAM
19	CALWORD_IN5	Diagnostics		RAM
20	RESERVED		Must be set to 0	RAM
21	TITSTCFG0	Diagnostics	<i>TI Test Registers. For TI Use Only (Must be set to 0)</i>	RAM
22	TITSTCFG1	Diagnostics		RAM
23	TITSTCFG2	Diagnostics		RAM
24	TITSTCFG3	Diagnostics		RAM
25	PRIACTIVITY	Status	Synthesizer Source Indicator (27:25) (Read only)	RAM
26	SECACTIVITY	Status	0 0 1 Primary Input	RAM
27	AUXACTIVITY	Status	0 1 0 Secondary Input 1 0 0 Auxiliary Input	RAM

9 Application and Implementation

NOTE

Information in the following applications sections is not part of the TI component specification, and TI does not warrant its accuracy or completeness. TI's customers are responsible for determining suitability of components for their purposes. Customers should validate and test their design implementation to confirm system functionality.

9.1 Application Information

9.1.1 Frequency Synthesizer

As shown in [Figure 47](#), the CDCE62005 has internal dividers, twin onboard VCOs, a phase frequency detector, charge pump, partially internal loop filter, and LVPECL/LVDS/LVCMOS input and output buffers, all of which completes a PLL. Through the PLL operation, the VCO clock synchronizes with the reference clock input and ultimately with all clock outputs. All outputs are completely synchronized in terms of phase and frequency with the reference clock input. When powering up from the EEPROM, the SYNC signal synchronizes outputs after device power-up.

See [SCAA096](#) for a detailed description of the application configuration.

9.2 Typical Application

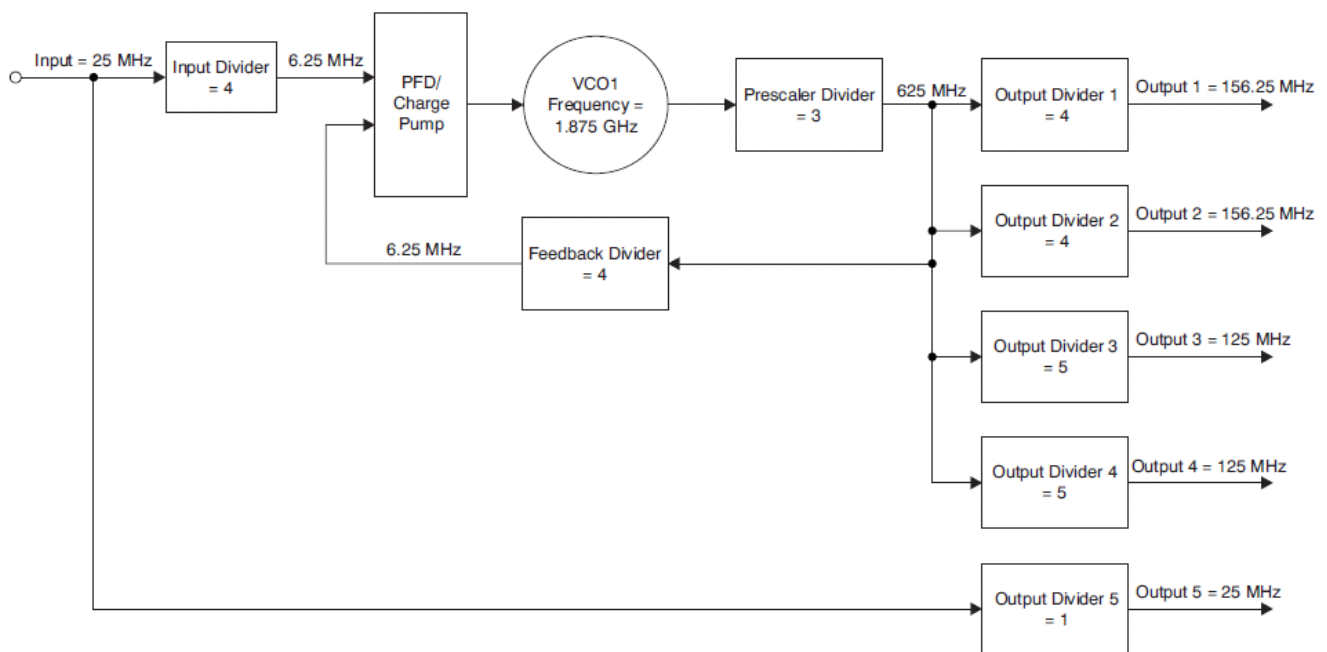

Figure 47. CDCE62005 Settings for Multiple Frequency Synthesis Example

9.2.1 Design Requirements

Assume a typical application, where a total of two 156.25-MHz LVPECL, two 125-MHz LVDS, and two 25-MHz LVCMOS output clocks are desired and should be phase-locked to a single back-plane input reference clock of 25 MHz. The goal of this example is to identify the input (M), prescaler (N), feedback (FB), and output (P) divider values, the VCO frequency to lock to, and the other related PLL settings needed to derive the different output frequencies from the common input and VCXO frequencies. Follow the steps outlined in [Detailed Design Procedure](#) to achieve this goal.

Typical Application (continued)

9.2.2 Detailed Design Procedure

Step 1. From [Figure 47](#), it can be inferred that the relationship between the output frequency and the input frequency is described by these equations,

where:

$$F_{VCO} = F_{OUT} \cdot P \cdot N \quad (17)$$

provided that:

$$80 \text{ kHz} < (F_{IN}/M) < 40 \text{ MHz} \quad (18)$$

and:

$$1750 \text{ MHz} < (F_{OUT} \cdot P \cdot N) < 2350 \text{ MHz} \quad (19)$$

Step 2. Keep in mind the following while satisfying the equations in Step 1:

- The P divider can be chosen to be 1, 2, 3, 4, 5, up to 80
- The internal VCO range is from 1.75 GHz to 2.35 GHz
- The input (M) and prescaler (N) dividers can be chosen from [Table 22](#) and [Table 26](#).
- The FB divider can be chosen from the values in [Table 23](#) and [Table 24](#).

Step 3. Given multiple desired output frequencies and the input frequency, the first step would be to establish M, N, and FB divider values for different P divider settings to satisfy these equations:

$$F_{IN} = F_{OUT1} \times (M \times P1) / (N \times FB) \quad (20)$$

$$F_{IN} = F_{OUT2} \times (M \times P2) / (N \times FB) \quad (21)$$

$$F_{IN} = F_{OUT3} \times (M \times P3) / (N \times FB) \quad (22)$$

$$F_{IN} = F_{OUT4} \times (M \times P4) / (N \times FB) \quad (23)$$

$$F_{IN} = F_{OUT5} \times (M \times P5) / (N \times FB) \quad (24)$$

$$(F_{VCO}/N) = F_{OUT1} \times P1 = F_{OUT2} \times P2 = F_{OUT3} \times P3 = F_{OUT4} \times P4 = F_{OUT5} \times P5 \quad (25)$$

Such that these parameters are valid:

- The common PFD frequency is always less than 40 MHz.
- The VCXO frequency is the same for deriving all outputs.

Using the example to derive these outputs, it can be seen that there is not an output divider (P5) that will generate a 25-MHz output. However, the output MUX value of output 5 can be chosen to directly bypass the 25-MHz input clock to output 5. Therefore, in order to use a common VCO frequency, the P dividers to be used are:

- P1 = 4
- P2 = 4
- P3 = 5
- P4 = 5
- P5 = 1

The common VCO frequency is 1875 MHz and is VCO1. The output MUX for outputs 1 to 4 are set to the PLL/VCO outputs. Moreover, the FB divider to be used is:

$$FB = 100 \quad (26)$$

The N divider to be used is:

$$N = 3 \quad (27)$$

These values ensure that the (FIN/M) ratio is within 40 MHz and is set at 6.25 MHz. Thus, the M divider to be used is:

$$M = 4 \quad (28)$$

[Figure 47](#) illustrates this configuration.

Typical Application (continued)

Step 4:

The PLL loop bandwidth of the CDCE62005 is recommended to be set according to the phase noise profile of its reference input and the phase noise profile of the onboard VCO clock. It is recommended to set the PLL loop bandwidth as the crossover point of the reference input phase noise and the phase noise of the VCO clock. When the input clock is clean and any near-frequency offsets are better than the VCO clock, it is beneficial for the PLL bandwidth to be set at several hundred kHz as determined by the crossover point. [Figure 48](#) shows a typical 400-kHz Loop filter.

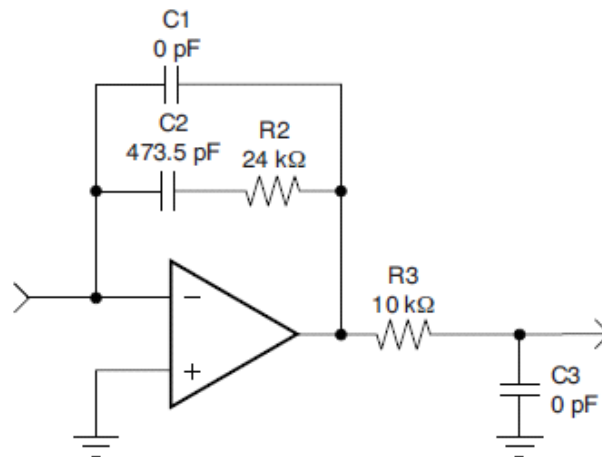
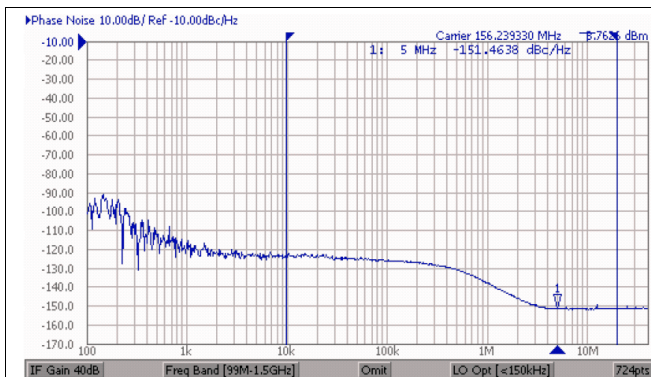

Figure 48. On-Chip Loop Filter Circuit for 400-kHz Loop Bandwidth
(Loop Settings in [Figure 47](#), CP Current at 3.5mA)

Typical Application (continued)

9.2.3 Application Curves



**Figure 49. Output 1/2 = 156.25MHz LVPECL
RMS Jitter is 520 fsec (10 kHz to 20 MHz)**

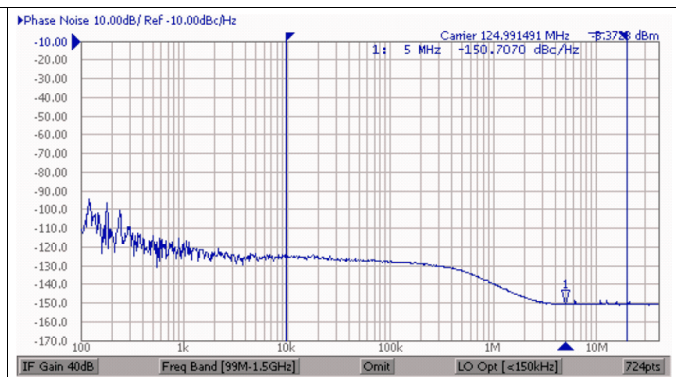

**Figure 50. Output 3/4 = 125MHz LVDS
RMS Jitter is 540 fsec (10 kHz to 20 MHz)**

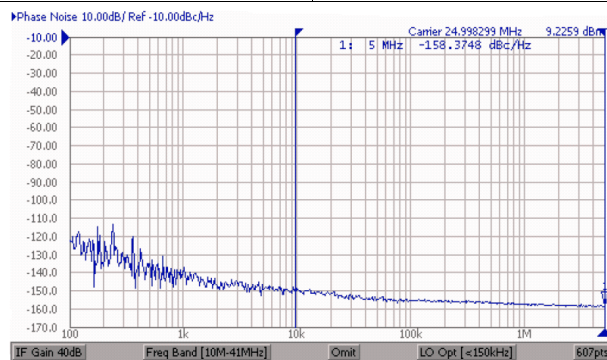

**Figure 51. Output 5 = 25MHz LVC MOS
RMS Jitter is 261 fsec (10 kHz to 5 MHz)**

10 Power Supply Recommendations

The CDCE62005 is a high performance device. Therefore careful attention must be paid to device configuration and printed circuit board layout with respect to power consumption. Table 49 provides the power consumption for the individual blocks within the CDCE62005. To estimate total power consumption, calculate the sum of the products of the number of blocks used and the power dissipated of each corresponding block.

Table 49. CDCE62005 Power Consumption

INTERNAL BLOCK POWER AT 3.3V (typ.)		POWER DISSIPATION/ BLOCK	NUMBER OF BLOCKS
Input Circuit		250 mW	1
PLL and VCO Core		500 mW	1
Output Dividers	Divider = 1	60 mW	5
	Divider > 1	180 mW	
LVPECL Output Buffer		75 mW ⁽¹⁾	5
LVDS Output Buffer		76 mW	5
LVCMOS Output Buffer	Static	7 mW	10
	Transient, C _L = load, f _{OUT} = MHz output frequency, V = output swing	$3.3 \times V \times f_{OUT} \times (C_L + 20 \times 10^{-12}) \times 10^3$	10

(1) An additional ~50 mW of power is dissipated externally at the termination resistors per LVPECL output pair.

This power estimate determines the degree of thermal management required for a specific design. Employing the thermally enhanced printed circuit board layout shown in Figure 53 ensures that the thermal performance curves shown in Figure 52 apply. Observing good thermal layout practices enables the thermal pad on the backside of the QFN-48 package to provide a good thermal path between the die contained within the package and the ambient air. This thermal pad also serves as the ground connection the device. Therefore, a low inductance connection to the ground plane is essential.

Figure 53 shows a layout optimized for good thermal performance and a good power supply connection as well. The 7x7 filled via pattern facilitates both considerations. Finally, the recommended layout achieves R_{θJA} = 27.3°C/W in still air and 20.3°C/W in an environment with 100 LFM airflow if implemented on a JEDEC compliant thermal test board..

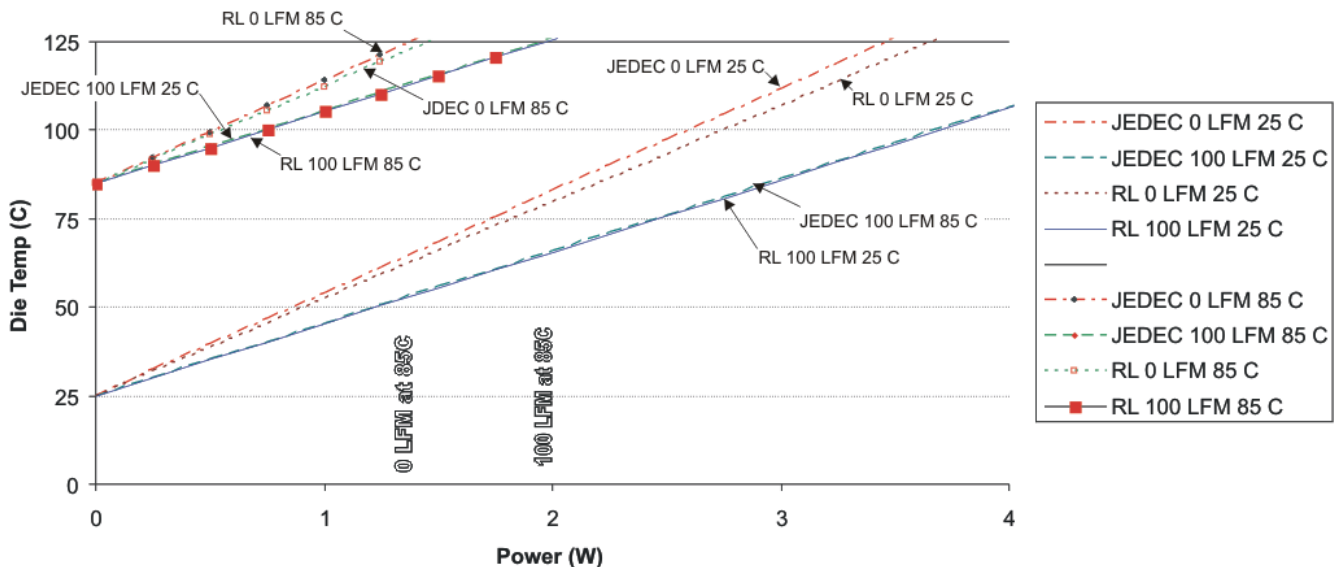

Figure 52. CDCE62005 Die Temperature vs Total Device Power

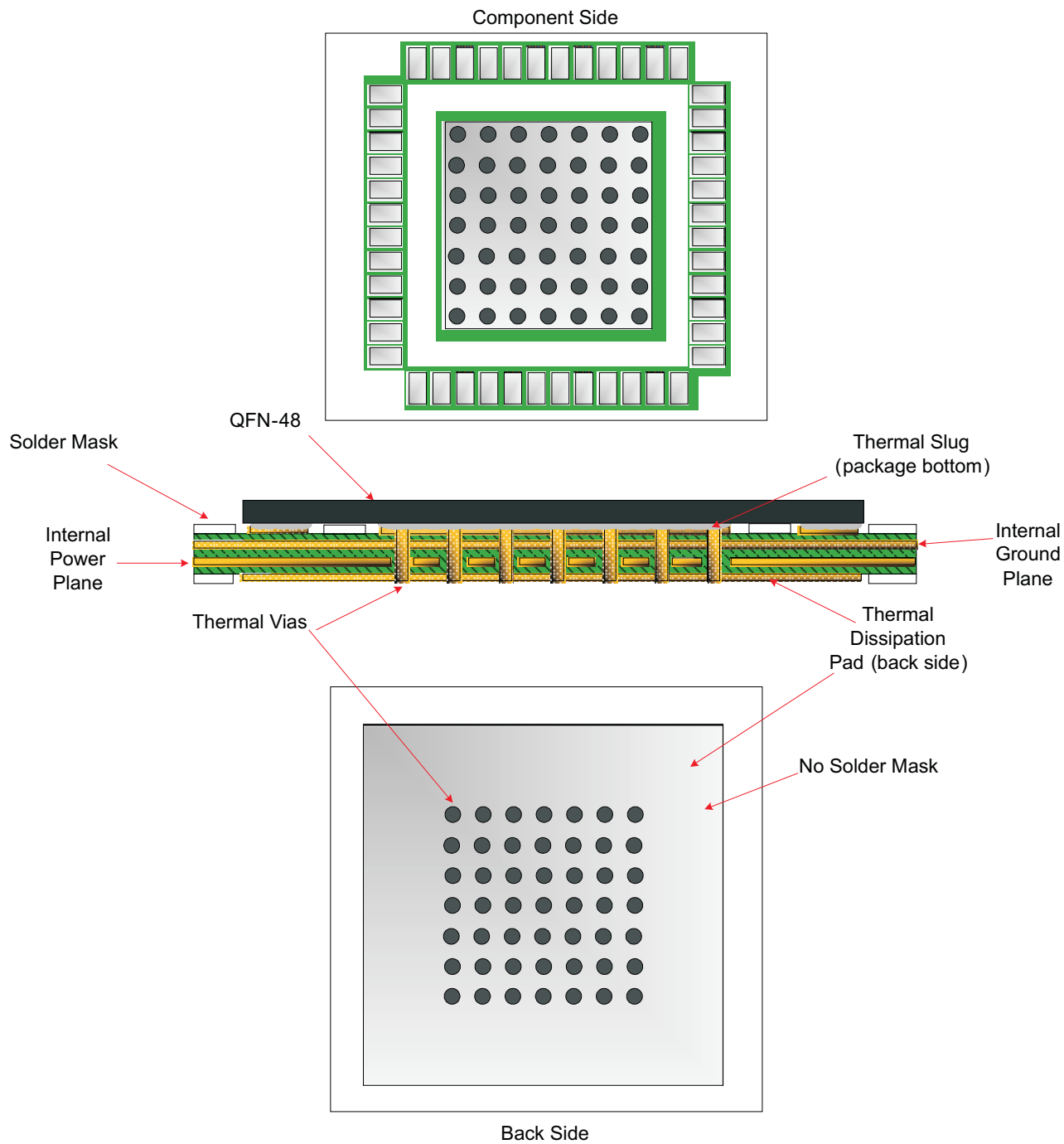

Figure 53. CDCE62005 Recommended PCB Layout

11 Layout

11.1 Layout Guidelines

Figure 54 shows two conceptual layouts detailing recommended placement of power supply bypass capacitors. If the capacitors are mounted on the back side, 0402 components can be employed; however, soldering to the Thermal Dissipation Pad can be difficult. For component side mounting, use 0201 body size capacitors to facilitate signal routing. Keep the connections between the bypass capacitors and the power supply on the device as short as possible. Ground the other side of the capacitor using a low impedance connection to the ground plane.

11.2 Layout Example

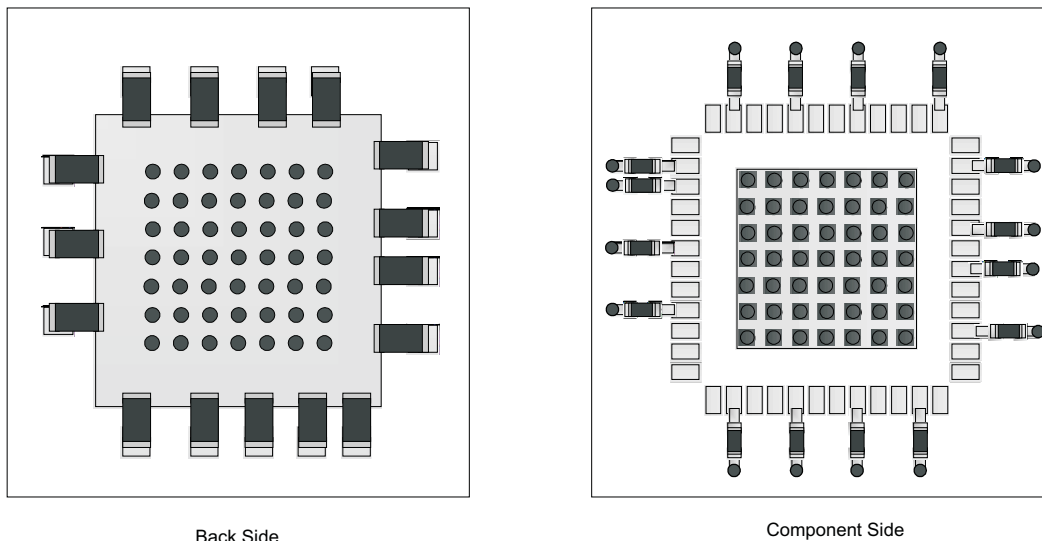

Figure 54. CDCE62005 Power Supply Bypassing

12 Device and Documentation Support

12.1 Trademarks

All trademarks are the property of their respective owners.

12.2 Documentation Support

For additional information, see *CDCE62005 Application Report (SCAA096)*.

12.3 Electrostatic Discharge Caution



These devices have limited built-in ESD protection. The leads should be shorted together or the device placed in conductive foam during storage or handling to prevent electrostatic damage to the MOS gates.

12.4 Glossary

[SLYZ022](#) — *TI Glossary*.

This glossary lists and explains terms, acronyms, and definitions.

13 Mechanical, Packaging, and Orderable Information

The following pages include mechanical, packaging, and orderable information. This information is the most current data available for the designated devices. This data is subject to change without notice and revision of this document. For browser-based versions of this data sheet, refer to the left-hand navigation.

PACKAGING INFORMATION

Orderable Device	Status (1)	Package Type	Package Drawing	Pins	Package Qty	Eco Plan (2)	Lead/Ball Finish (6)	MSL Peak Temp (3)	Op Temp (°C)	Device Marking (4/5)	Samples
CDCE62005RGZR	ACTIVE	VQFN	RGZ	48	2500	Green (RoHS & no Sb/Br)	CU NIPDAU	Level-3-260C-168 HR	-40 to 85	CDCE 62005	Samples
CDCE62005RGZT	ACTIVE	VQFN	RGZ	48	250	Green (RoHS & no Sb/Br)	CU NIPDAU	Level-3-260C-168 HR	-40 to 85	CDCE 62005	Samples

(1) The marketing status values are defined as follows:

ACTIVE: Product device recommended for new designs.

LIFEBUY: TI has announced that the device will be discontinued, and a lifetime-buy period is in effect.

NRND: Not recommended for new designs. Device is in production to support existing customers, but TI does not recommend using this part in a new design.

PREVIEW: Device has been announced but is not in production. Samples may or may not be available.

OBsolete: TI has discontinued the production of the device.

(2) Eco Plan - The planned eco-friendly classification: Pb-Free (RoHS), Pb-Free (RoHS Exempt), or Green (RoHS & no Sb/Br) - please check <http://www.ti.com/productcontent> for the latest availability information and additional product content details.

TBD: The Pb-Free/Green conversion plan has not been defined.

Pb-Free (RoHS): TI's terms "Lead-Free" or "Pb-Free" mean semiconductor products that are compatible with the current RoHS requirements for all 6 substances, including the requirement that lead not exceed 0.1% by weight in homogeneous materials. Where designed to be soldered at high temperatures, TI Pb-Free products are suitable for use in specified lead-free processes.

Pb-Free (RoHS Exempt): This component has a RoHS exemption for either 1) lead-based flip-chip solder bumps used between the die and package, or 2) lead-based die adhesive used between the die and leadframe. The component is otherwise considered Pb-Free (RoHS compatible) as defined above.

Green (RoHS & no Sb/Br): TI defines "Green" to mean Pb-Free (RoHS compatible), and free of Bromine (Br) and Antimony (Sb) based flame retardants (Br or Sb do not exceed 0.1% by weight in homogeneous material)

(3) MSL, Peak Temp. - The Moisture Sensitivity Level rating according to the JEDEC industry standard classifications, and peak solder temperature.

(4) There may be additional marking, which relates to the logo, the lot trace code information, or the environmental category on the device.

(5) Multiple Device Markings will be inside parentheses. Only one Device Marking contained in parentheses and separated by a "~" will appear on a device. If a line is indented then it is a continuation of the previous line and the two combined represent the entire Device Marking for that device.

(6) Lead/Ball Finish - Orderable Devices may have multiple material finish options. Finish options are separated by a vertical ruled line. Lead/Ball Finish values may wrap to two lines if the finish value exceeds the maximum column width.

Important Information and Disclaimer: The information provided on this page represents TI's knowledge and belief as of the date that it is provided. TI bases its knowledge and belief on information provided by third parties, and makes no representation or warranty as to the accuracy of such information. Efforts are underway to better integrate information from third parties. TI has taken and continues to take reasonable steps to provide representative and accurate information but may not have conducted destructive testing or chemical analysis on incoming materials and chemicals. TI and TI suppliers consider certain information to be proprietary, and thus CAS numbers and other limited information may not be available for release.

In no event shall TI's liability arising out of such information exceed the total purchase price of the TI part(s) at issue in this document sold by TI to Customer on an annual basis.

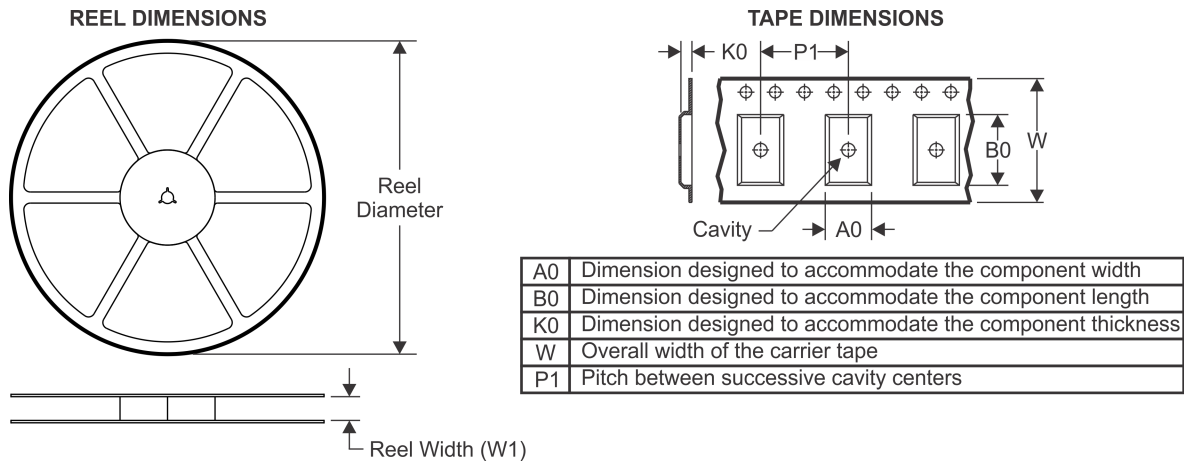
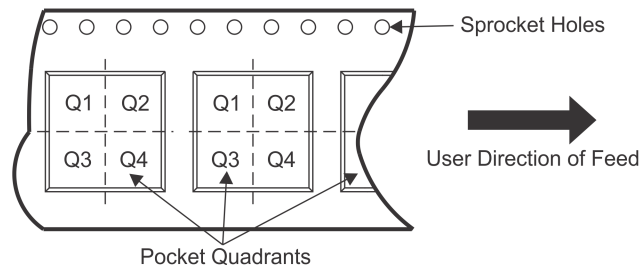
TAPE AND REEL INFORMATION

QUADRANT ASSIGNMENTS FOR PIN 1 ORIENTATION IN TAPE

*All dimensions are nominal

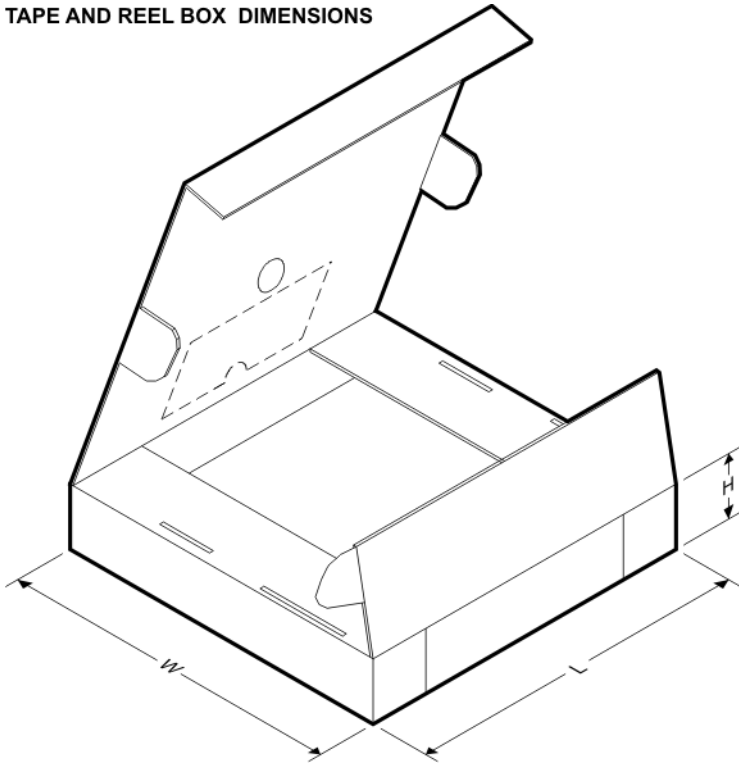
Device	Package Type	Package Drawing	Pins	SPQ	Reel Diameter (mm)	Reel Width W1 (mm)	A0 (mm)	B0 (mm)	K0 (mm)	P1 (mm)	W (mm)	Pin1 Quadrant
CDCE62005RGZR	VQFN	RGZ	48	2500	330.0	16.4	7.3	7.3	1.5	12.0	16.0	Q2
CDCE62005RGZT	VQFN	RGZ	48	250	180.0	16.4	7.3	7.3	1.5	12.0	16.0	Q2

TAPE AND REEL BOX DIMENSIONS

*All dimensions are nominal

Device	Package Type	Package Drawing	Pins	SPQ	Length (mm)	Width (mm)	Height (mm)
CDCE62005RGZR	VQFN	RGZ	48	2500	350.0	350.0	43.0
CDCE62005RGZT	VQFN	RGZ	48	250	213.0	191.0	55.0

GENERIC PACKAGE VIEW

RGZ 48

VQFN - 1 mm max height

7 x 7, 0.5 mm pitch

PLASTIC QUADFLAT PACK- NO LEAD

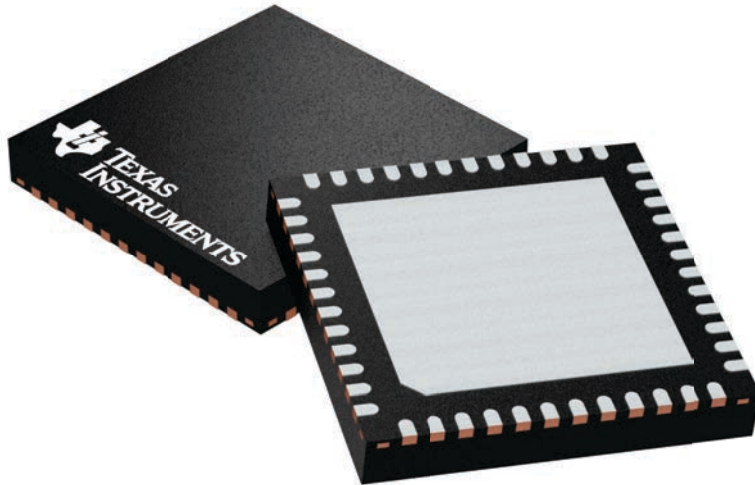

Images above are just a representation of the package family, actual package may vary.
Refer to the product data sheet for package details.

4224671/A

RGZ0048D

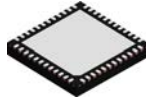

PACKAGE OUTLINE

VQFN - 1 mm max height

PLASTIC QUAD FLATPACK - NO LEAD

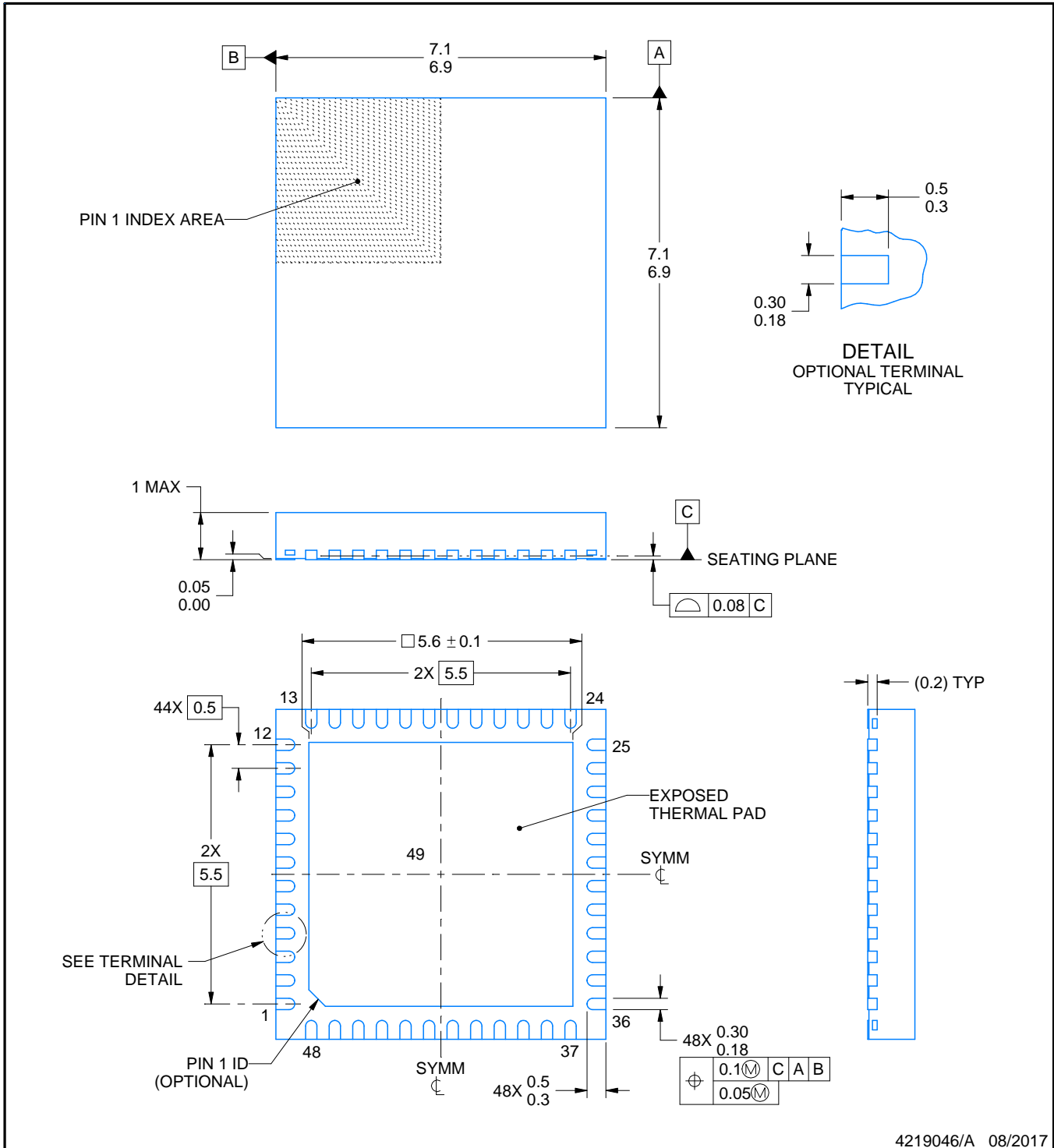

4219046/A 08/2017

NOTES:

1. All linear dimensions are in millimeters. Any dimensions in parenthesis are for reference only. Dimensioning and tolerancing per ASME Y14.5M.
2. This drawing is subject to change without notice.
3. The package thermal pad must be soldered to the printed circuit board for thermal and mechanical performance.

EXAMPLE BOARD LAYOUT

RGZ0048D

VQFN - 1 mm max height

PLASTIC QUAD FLATPACK - NO LEAD

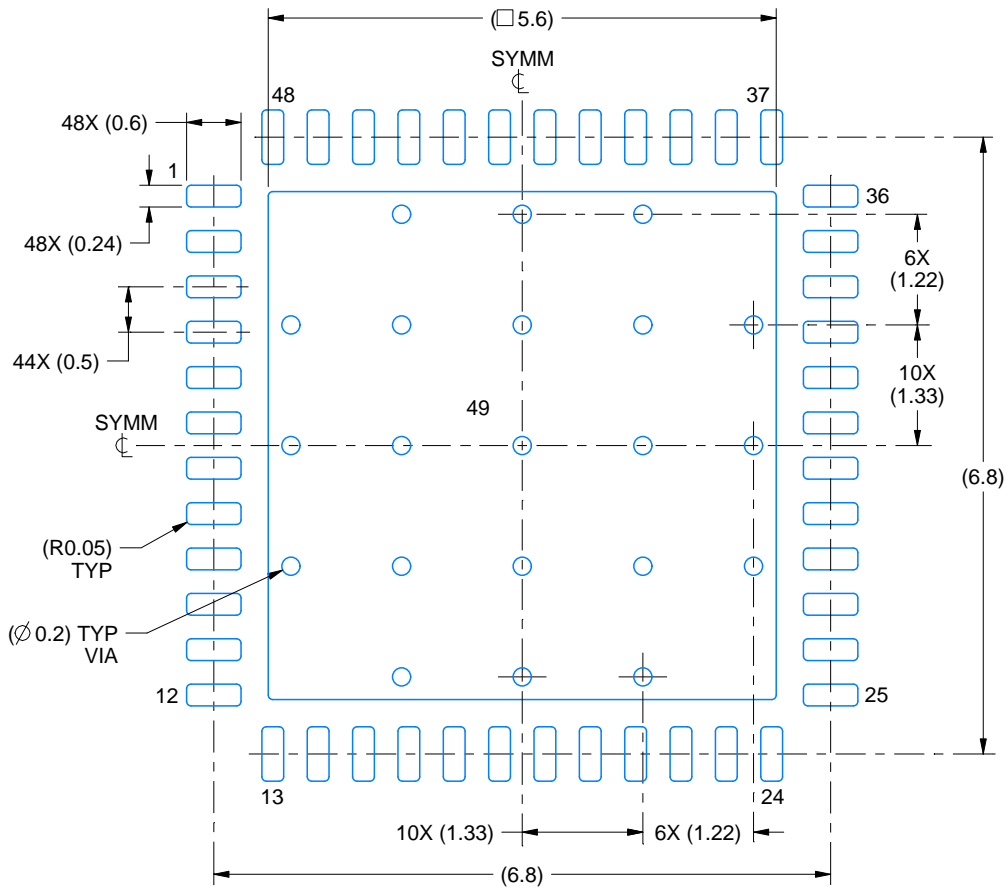

LAND PATTERN EXAMPLE
EXPOSED METAL SHOWN
SCALE:12X

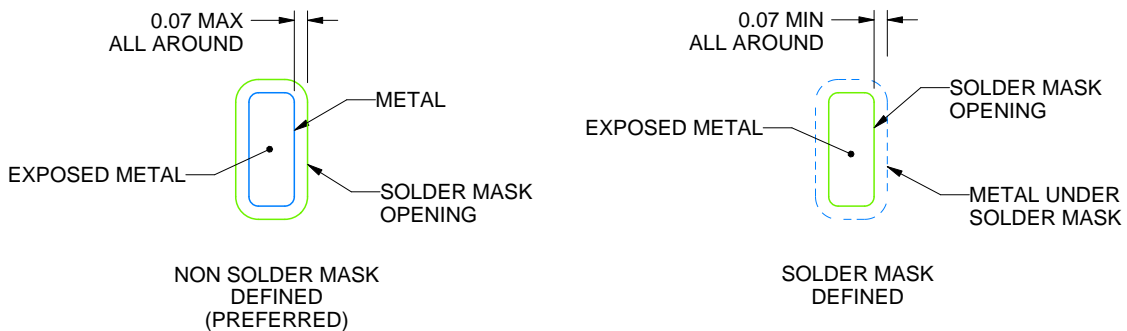

SOLDER MASK DETAILS

4219046/A 08/2017

NOTES: (continued)

4. This package is designed to be soldered to a thermal pad on the board. For more information, see Texas Instruments literature number SLUA271 (www.ti.com/lit/sluea271).
5. Vias are optional depending on application, refer to device data sheet. If any vias are implemented, refer to their locations shown on this view. It is recommended that vias under paste be filled, plugged or tented.

EXAMPLE STENCIL DESIGN

RGZ0048D

VQFN - 1 mm max height

PLASTIC QUAD FLATPACK - NO LEAD

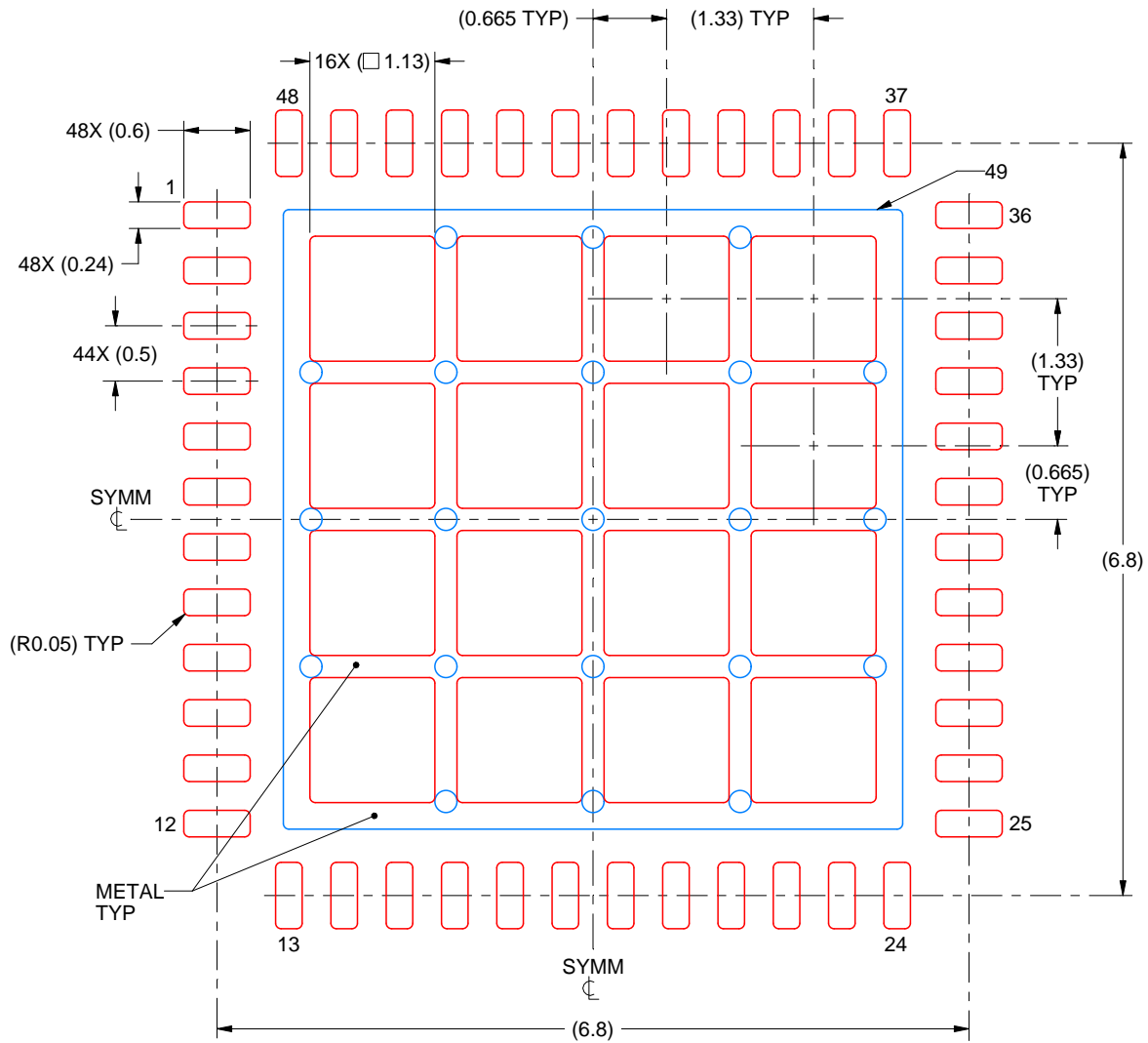

SOLDER PASTE EXAMPLE
BASED ON 0.125 mm THICK STENCIL

EXPOSED PAD 49
66% PRINTED SOLDER COVERAGE BY AREA UNDER PACKAGE
SCALE:15X

4219046/A 08/2017

NOTES: (continued)

6. Laser cutting apertures with trapezoidal walls and rounded corners may offer better paste release. IPC-7525 may have alternate design recommendations.

IMPORTANT NOTICE AND DISCLAIMER

TI PROVIDES TECHNICAL AND RELIABILITY DATA (INCLUDING DATASHEETS), DESIGN RESOURCES (INCLUDING REFERENCE DESIGNS), APPLICATION OR OTHER DESIGN ADVICE, WEB TOOLS, SAFETY INFORMATION, AND OTHER RESOURCES "AS IS" AND WITH ALL FAULTS, AND DISCLAIMS ALL WARRANTIES, EXPRESS AND IMPLIED, INCLUDING WITHOUT LIMITATION ANY IMPLIED WARRANTIES OF MERCHANTABILITY, FITNESS FOR A PARTICULAR PURPOSE OR NON-INFRINGEMENT OF THIRD PARTY INTELLECTUAL PROPERTY RIGHTS.

These resources are intended for skilled developers designing with TI products. You are solely responsible for (1) selecting the appropriate TI products for your application, (2) designing, validating and testing your application, and (3) ensuring your application meets applicable standards, and any other safety, security, or other requirements. These resources are subject to change without notice. TI grants you permission to use these resources only for development of an application that uses the TI products described in the resource. Other reproduction and display of these resources is prohibited. No license is granted to any other TI intellectual property right or to any third party intellectual property right. TI disclaims responsibility for, and you will fully indemnify TI and its representatives against, any claims, damages, costs, losses, and liabilities arising out of your use of these resources.

TI's products are provided subject to TI's Terms of Sale (www.ti.com/legal/termsofsale.html) or other applicable terms available either on ti.com or provided in conjunction with such TI products. TI's provision of these resources does not expand or otherwise alter TI's applicable warranties or warranty disclaimers for TI products.

Mailing Address: Texas Instruments, Post Office Box 655303, Dallas, Texas 75265
Copyright © 2019, Texas Instruments Incorporated

Looking for pricing, stock, or lifecycle information?

Click below to explore more details on WIN SOURCE:

 [View CDCE62005RGZT on WIN SOURCE](#)

 [Texas Instruments](#) Information

Optimize Your Supply Chain with WIN SOURCE Solutions

-  Global Sourcing Solution
-  Obsolete Management
-  Cost Control Management
-  Shortage Management
-  Alternative Solution
-  Excess Inventory Management