



**THE DATASHEET OF
CDC339DB**



CDC339 CLOCK DRIVER WITH 3-STATE OUTPUTS

SCAS331 – DECEMBER 1992 – REVISED MARCH 1994

- Low Output Skew, Low Pulse Skew for Clock-Distribution and Clock-Generation Applications
- TTL-Compatible Inputs and Outputs
- Distributes One Clock Input to Eight Outputs
 - Four Same-Frequency Outputs
 - Four Half-Frequency Outputs
- Distributed V_{CC} and Ground Pins Reduce Switching Noise
- High-Drive Outputs ($-48\text{-mA } I_{OH}$, $48\text{-mA } I_{OL}$)
- State-of-the-Art EPIC-IIB™ BiCMOS Design Significantly Reduces Power Dissipation
- Package Options Include Plastic Small-Outline (DW) and Shrink Small-Outline (DB) Packages

DB OR DW PACKAGE
(TOP VIEW)

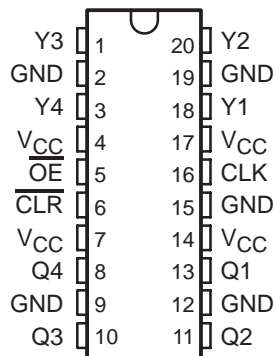

description

The CDC339 is a high-performance, low-skew clock driver. It is specifically designed for applications requiring synchronized output signals at both the primary clock frequency and one-half the primary clock frequency. The four Y outputs switch in phase and at the same frequency as the clock (CLK) input. The four Q outputs switch at one-half the frequency of CLK.

When the output-enable (\overline{OE}) input is low and the clear (\overline{CLR}) input is high, the Y outputs follow CLK and the Q outputs toggle on low-to-high transitions of CLK. Taking CLR low asynchronously resets the Q outputs to the low level. When \overline{OE} is high, the outputs are in the high-impedance state.

The CDC339 is characterized for operation from -40°C to 85°C .

FUNCTION TABLE

INPUTS			OUTPUTS	
\overline{OE}	\overline{CLR}	CLK	Y1–Y4	Q1–Q4
H	X	X	Z	Z
L	L	L	L	L
L	L	H	H	L
L	H	L	L	Q_0^{\dagger}
L	H	\uparrow	H	$\overline{Q_0}^{\dagger}$

† The level of the Q outputs before the indicated steady-state input conditions were established.



Please be aware that an important notice concerning availability, standard warranty, and use in critical applications of Texas Instruments semiconductor products and disclaimers thereto appears at the end of this data sheet.

EPIC-IIB is a trademark of Texas Instruments Incorporated.

PRODUCTION DATA information is current as of publication date. Products conform to specifications per the terms of Texas Instruments standard warranty. Production processing does not necessarily include testing of all parameters.

 **TEXAS
INSTRUMENTS**

POST OFFICE BOX 655303 • DALLAS, TEXAS 75265

Copyright © 1994, Texas Instruments Incorporated

CDC339 CLOCK DRIVER WITH 3-STATE OUTPUTS

SCAS331 – DECEMBER 1992 – REVISED MARCH 1994

logic symbol†

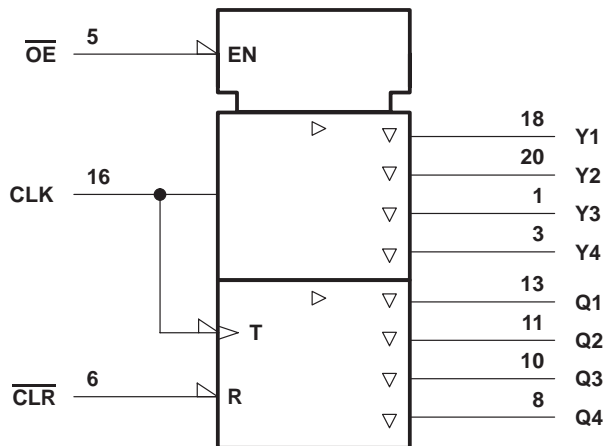

† This symbol is in accordance with ANSI/IEEE Std 91-1984 and IEC Publication 617-12.

logic diagram (positive logic)

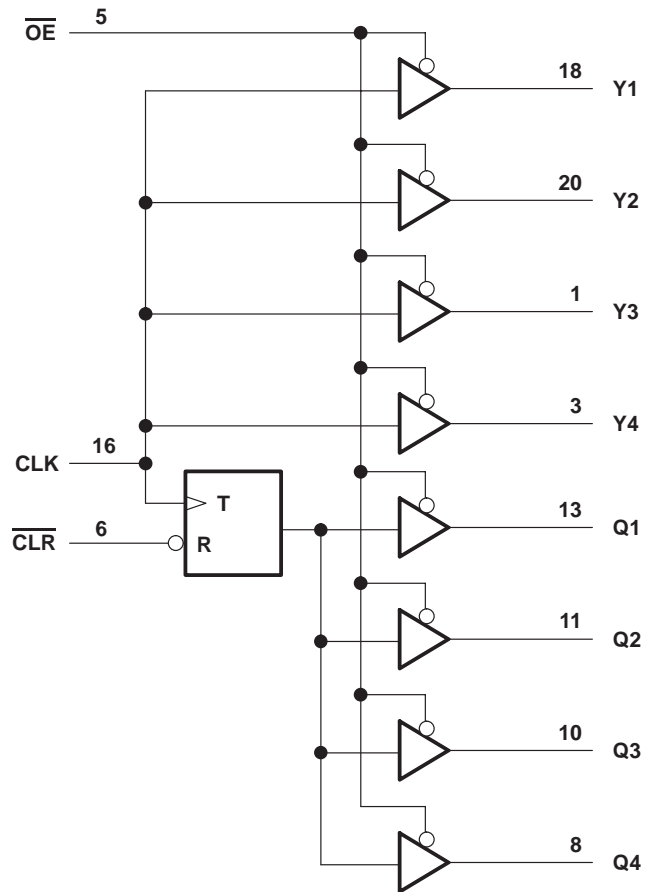

absolute maximum ratings over operating free-air temperature range (unless otherwise noted)‡

Supply voltage range, V_{CC}	-0.5 V to 7 V
Input voltage range, V_I (see Note 1)	-0.5 V to 7 V
Voltage range applied to any output in the disabled or power-off state, V_O	-0.5 V to 5.5 V
Current into any output in the low state, I_O	96 mA
Input clamp current, I_{IK} ($V_I < 0$)	-18 mA
Output clamp current, I_{OK} ($V_O < 0$)	-50 mA
Maximum power dissipation at $T_A = 55^\circ\text{C}$ (in still air) (see Note 2): DB package	0.6 W
..... DW package	1.6 W
Storage temperature range, T_{stg}	-65°C to 150°C

‡ Stresses beyond those listed under "absolute maximum ratings" may cause permanent damage to the device. These are stress ratings only, and functional operation of the device at these or any other conditions beyond those indicated under "recommended operating conditions" is not implied. Exposure to absolute-maximum-rated conditions for extended periods may affect device reliability.

NOTES: 1. The input and output negative-voltage ratings may be exceeded if the input and output clamp-current ratings are observed.
2. The maximum package power dissipation is calculated using a junction temperature of 150°C and a board trace length of 750 mils. For more information, refer to the *Package Thermal Considerations* application note in the 1994 *ABT Advanced BiCMOS Technology Data Book*, literature number SCBD002B.

CDC339 CLOCK DRIVER WITH 3-STATE OUTPUTS

SCAS331 – DECEMBER 1992 – REVISED MARCH 1994

recommended operating conditions (see Note 3)

		MIN	MAX	UNIT
V_{CC}	Supply voltage	4.75	5.25	V
V_{IH}	High-level input voltage	2		V
V_{IL}	Low-level input voltage		0.8	V
V_I	Input voltage	0	V_{CC}	V
I_{OH}	High-level output current		-48	mA
I_{OL}	Low-level output current		48	mA
f_{clock}	Input clock frequency		80	MHz
T_A	Operating free-air temperature	-40	85	°C

NOTE 3: Unused pins (input or I/O) must be held high or low.

electrical characteristics over recommended operating free-air temperature range (unless otherwise noted)

PARAMETER	TEST CONDITIONS		MIN	TYP†	MAX	UNIT
V_{IK}	$V_{CC} = 4.75$ V,	$I_I = -18$ mA			-1.2	V
V_{OH}	$V_{CC} = 4.75$ V,	$I_{OH} = -48$ mA	2			V
V_{OL}	$V_{CC} = 4.75$ V,	$I_{OL} = 48$ mA			0.5	V
I_{IH}	$V_{CC} = 5.25$ V,	$V_I = 2.7$ V			50	μA
I_{IL}	$V_{CC} = 5.25$ V,	$V_I = 0.5$ V			-50	μA
I_{OZ}	$V_{CC} = 5.25$ V,	$V_O = 2.7$ V or 0.5 V			±50	μA
$I_{O‡}$	$V_{CC} = 5.25$ V,	$V_O = 2.5$ V	-50		-180	mA
I_{CC}	$V_{CC} = 5.25$ V, $V_I = V_{CC}$ or GND	$I_O = 0$,	Outputs high		70	mA
			Outputs low		85	
			Outputs disabled		70	
C_i	$V_I = 2.5$ V or 0.5 V				3	pF
C_o	$V_O = 2.5$ V or 0.5 V				8	pF

† All typical values are at $V_{CC} = 5$ V, $T_A = 25$ °C.

‡ Not more than one output should be tested at a time, and the duration of the test should not exceed one second.

timing requirements over recommended ranges of supply voltage and operating free-air temperature

		MIN	MAX	UNIT	
f_{clock}	Clock frequency		80	MHz	
t_w	Pulse duration	\overline{CLR} low	4	ns	
		CLK low	4		
		CLK high	4		
t_{su}	Setup time	\overline{CLR} inactive before $CLK\uparrow$		2	ns
	Clock duty cycle	40%	60%		

CDC339
CLOCK DRIVER
WITH 3-STATE OUTPUTS

SCAS331 – DECEMBER 1992 – REVISED MARCH 1994

switching characteristics over recommended ranges of supply voltage and operating free-air temperature (see Figures 1 and 2)

PARAMETER	FROM (INPUT)	TO (OUTPUT)	MIN	TYP†	MAX	UNIT
f_{max}			80			MHz
t_{PLH}	CLK	Any Y or Q	3		9	ns
t_{PHL}			3		9	
t_{PHL}	\overline{CLR}	Any Q	4		9	ns
t_{PZH}	\overline{OE}	Any Y or Q	2		7	ns
t_{PZL}			3		7	
t_{PHZ}	\overline{OE}	Any Y or Q	2		7	ns
t_{PLZ}			2		7	
$t_{sk(o)}$	CLK↑	Y↑			0.75	ns
		Q↑			0.9	
		Y↑ and Q↑			0.9	
t_r				0.9		ns
t_f				0.7		ns

† All typical values are at $V_{CC} = 5\text{ V}$, $T_A = 25^\circ\text{C}$.

PARAMETER MEASUREMENT INFORMATION

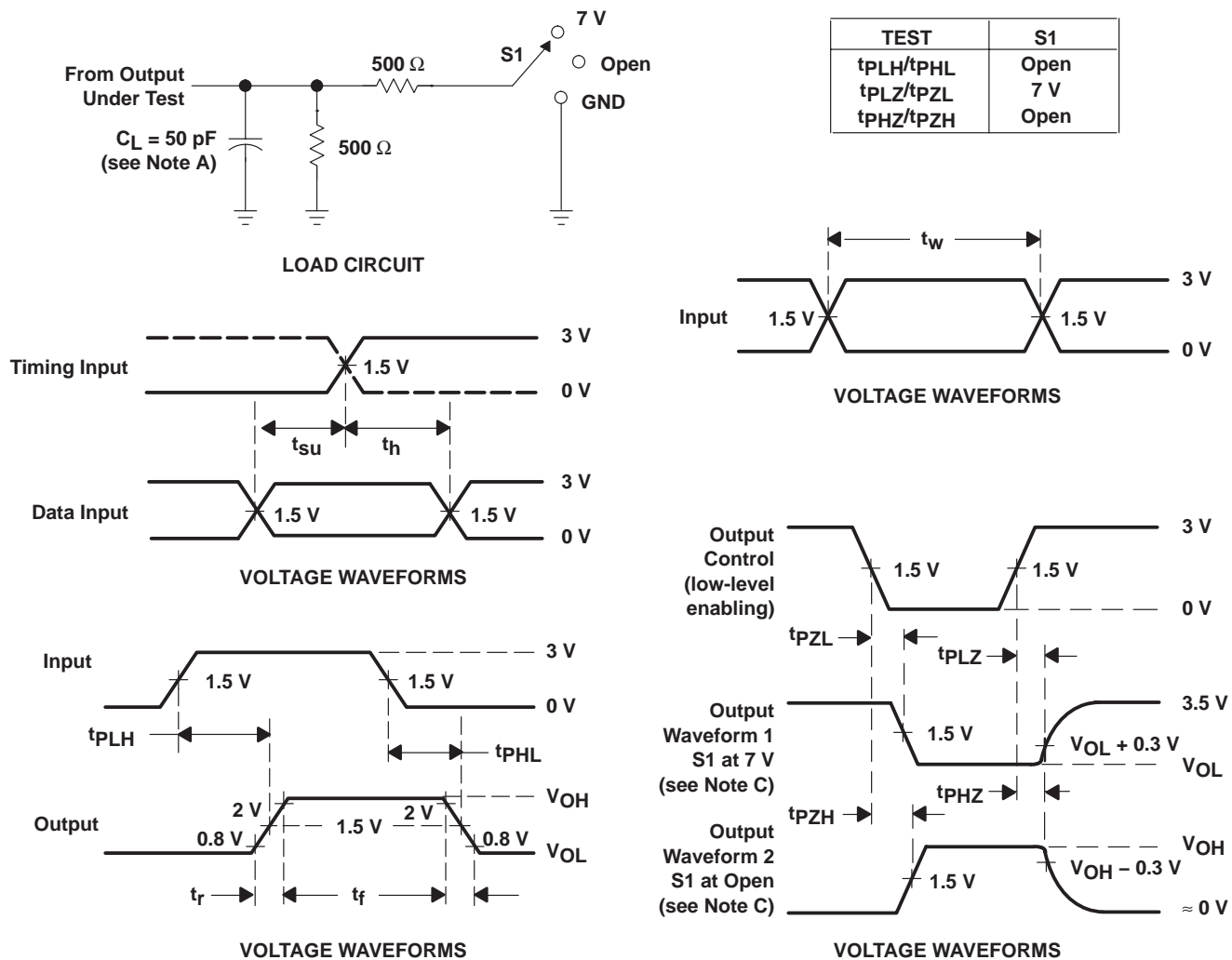

- NOTES: A. C_L includes probe and jig capacitance.
 B. All input pulses are supplied by generators having the following characteristics: $PRR \leq 10 \text{ MHz}$, $Z_O = 50 \Omega$, $t_r \leq 2.5 \text{ ns}$, $t_f \leq 2.5 \text{ ns}$.
 C. Waveform 1 is for an output with internal conditions such that the output is low except when disabled by the output control. Waveform 2 is for an output with internal conditions such that the output is high except when disabled by the output control.
 D. The outputs are measured one at a time with one transition per measurement.

Figure 1. Load Circuit and Voltage Waveforms

**CDC339
CLOCK DRIVER
WITH 3-STATE OUTPUTS**

SCAS331 – DECEMBER 1992 – REVISED MARCH 1994

PARAMETER MEASUREMENT INFORMATION

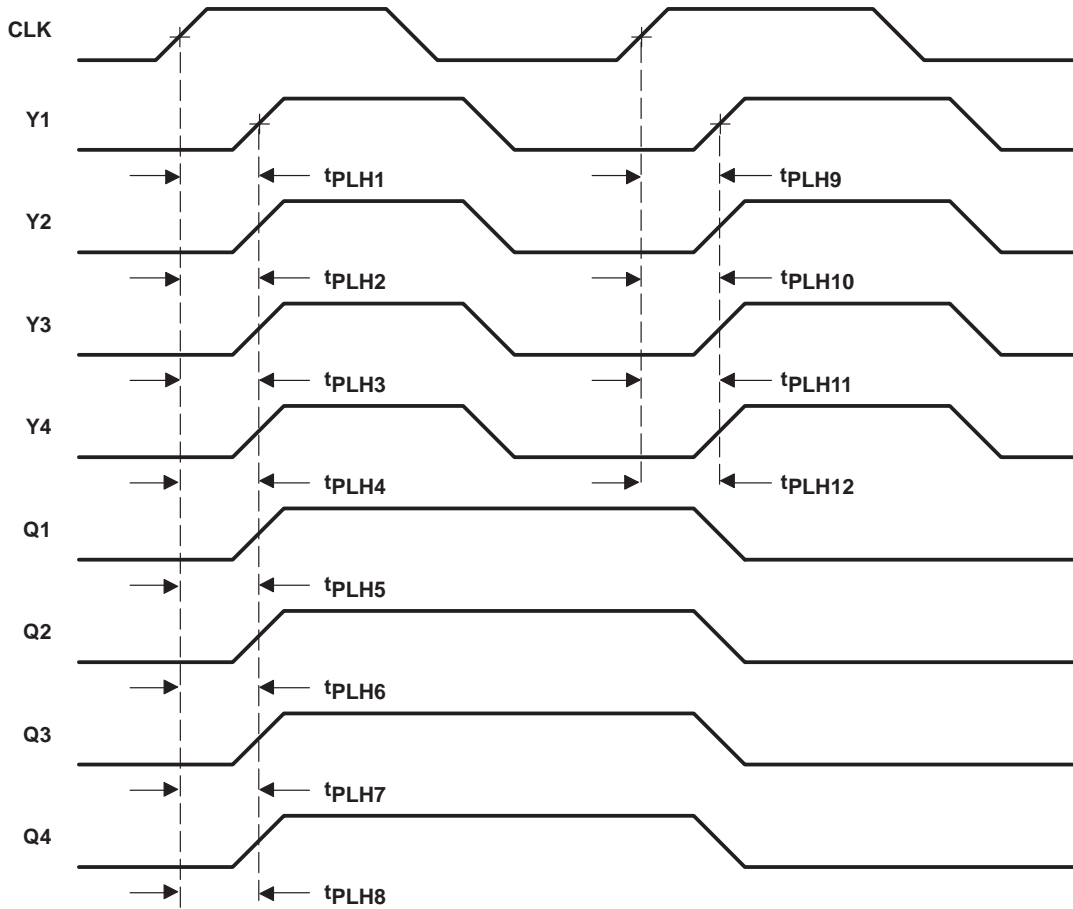

- NOTES: A. Output skew, $t_{sk(o)}$, from $CLK\uparrow$ to $Y\uparrow$, is calculated as the greater of the difference between the fastest and slowest of t_{PLHn} ($n = 1, 2, 3, 4$) or t_{PLHn} ($n = 9, 10, 11, 12$).
- B. Output skew, $t_{sk(o)}$, from $CLK\uparrow$ to $Q\uparrow$, is calculated as the greater of the difference between the fastest and slowest of t_{PLHn} ($n = 5, 6, 7, 8$).
- C. Output skew, $t_{sk(o)}$, from $CLK\uparrow$ to $Y\uparrow$ and $Q\uparrow$, is calculated as the greater of the difference between the fastest and slowest of t_{PLHn} ($n = 1, 2, \dots, 8$).

Figure 2. Skew Waveforms and Calculations

PACKAGING INFORMATION

Orderable Device	Status (1)	Package Type	Package Drawing	Pins	Package Qty	Eco Plan (2)	Lead/Ball Finish (6)	MSL Peak Temp (3)	Op Temp (°C)	Device Marking (4/5)	Samples
CDC339DB	ACTIVE	SSOP	DB	20	70	Green (RoHS & no Sb/Br)	CU NIPDAU	Level-1-260C-UNLIM	-40 to 85	CK339	Samples
CDC339DBG4	ACTIVE	SSOP	DB	20	70	Green (RoHS & no Sb/Br)	CU NIPDAU	Level-1-260C-UNLIM	-40 to 85	CK339	Samples
CDC339DBG4	ACTIVE	SSOP	DB	20	70	Green (RoHS & no Sb/Br)	CU NIPDAU	Level-1-260C-UNLIM	-40 to 85	CK339	Samples
CDC339DW	ACTIVE	SOIC	DW	20	25	Green (RoHS & no Sb/Br)	CU NIPDAU	Level-1-260C-UNLIM	-40 to 85	CDC339	Samples
CDC339DW	ACTIVE	SOIC	DW	20	25	Green (RoHS & no Sb/Br)	CU NIPDAU	Level-1-260C-UNLIM	-40 to 85	CDC339	Samples
CDC339DWG4	ACTIVE	SOIC	DW	20	25	Green (RoHS & no Sb/Br)	CU NIPDAU	Level-1-260C-UNLIM	-40 to 85	CDC339	Samples
CDC339DWG4	ACTIVE	SOIC	DW	20	25	Green (RoHS & no Sb/Br)	CU NIPDAU	Level-1-260C-UNLIM	-40 to 85	CDC339	Samples

(1) The marketing status values are defined as follows:

ACTIVE: Product device recommended for new designs.

LIFEBUY: TI has announced that the device will be discontinued, and a lifetime-buy period is in effect.

NRND: Not recommended for new designs. Device is in production to support existing customers, but TI does not recommend using this part in a new design.

PREVIEW: Device has been announced but is not in production. Samples may or may not be available.

OBSOLETE: TI has discontinued the production of the device.

(2) Eco Plan - The planned eco-friendly classification: Pb-Free (RoHS), Pb-Free (RoHS Exempt), or Green (RoHS & no Sb/Br) - please check <http://www.ti.com/productcontent> for the latest availability information and additional product content details.

TBD: The Pb-Free/Green conversion plan has not been defined.

Pb-Free (RoHS): TI's terms "Lead-Free" or "Pb-Free" mean semiconductor products that are compatible with the current RoHS requirements for all 6 substances, including the requirement that lead not exceed 0.1% by weight in homogeneous materials. Where designed to be soldered at high temperatures, TI Pb-Free products are suitable for use in specified lead-free processes.

Pb-Free (RoHS Exempt): This component has a RoHS exemption for either 1) lead-based flip-chip solder bumps used between the die and package, or 2) lead-based die adhesive used between the die and leadframe. The component is otherwise considered Pb-Free (RoHS compatible) as defined above.

Green (RoHS & no Sb/Br): TI defines "Green" to mean Pb-Free (RoHS compatible), and free of Bromine (Br) and Antimony (Sb) based flame retardants (Br or Sb do not exceed 0.1% by weight in homogeneous material)

(3) MSL, Peak Temp. - The Moisture Sensitivity Level rating according to the JEDEC industry standard classifications, and peak solder temperature.

(4) There may be additional marking, which relates to the logo, the lot trace code information, or the environmental category on the device.

⁽⁵⁾ Multiple Device Markings will be inside parentheses. Only one Device Marking contained in parentheses and separated by a "-" will appear on a device. If a line is indented then it is a continuation of the previous line and the two combined represent the entire Device Marking for that device.

⁽⁶⁾ Lead/Ball Finish - Orderable Devices may have multiple material finish options. Finish options are separated by a vertical ruled line. Lead/Ball Finish values may wrap to two lines if the finish value exceeds the maximum column width.

Important Information and Disclaimer:The information provided on this page represents TI's knowledge and belief as of the date that it is provided. TI bases its knowledge and belief on information provided by third parties, and makes no representation or warranty as to the accuracy of such information. Efforts are underway to better integrate information from third parties. TI has taken and continues to take reasonable steps to provide representative and accurate information but may not have conducted destructive testing or chemical analysis on incoming materials and chemicals. TI and TI suppliers consider certain information to be proprietary, and thus CAS numbers and other limited information may not be available for release.

In no event shall TI's liability arising out of such information exceed the total purchase price of the TI part(s) at issue in this document sold by TI to Customer on an annual basis.

DB0020A

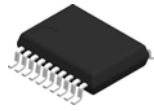

PACKAGE OUTLINE

TSSOP - 2 mm max height

SMALL OUTLINE PACKAGE

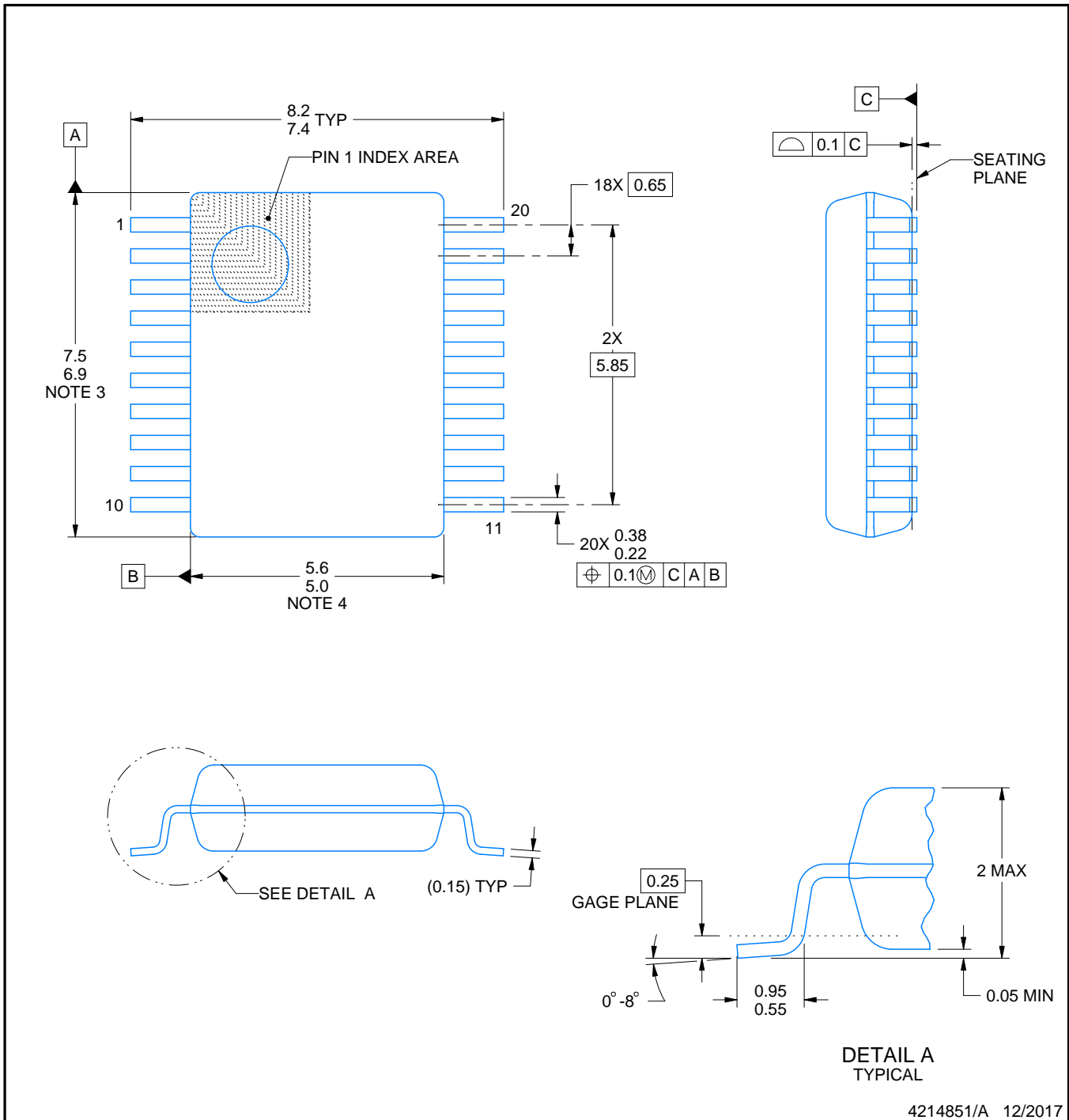

NOTES:

1. All linear dimensions are in millimeters. Any dimensions in parenthesis are for reference only. Dimensioning and tolerancing per ASME Y14.5M.
2. This drawing is subject to change without notice.
3. This dimension does not include mold flash, protrusions, or gate burrs. Mold flash, protrusions, or gate burrs shall not exceed 0.15 mm per side.
4. This dimension does not include interlead flash. Interlead flash shall not exceed 0.25 mm per side.
5. Reference JEDEC registration MO-150.

EXAMPLE BOARD LAYOUT

DB0020A

TSSOP - 2 mm max height

SMALL OUTLINE PACKAGE

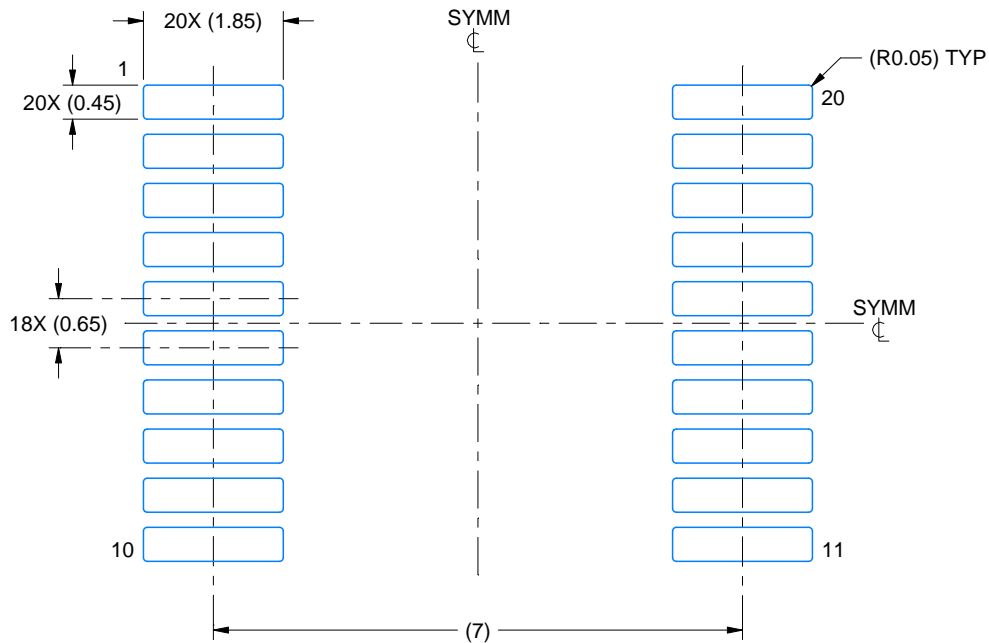

LAND PATTERN EXAMPLE
EXPOSED METAL SHOWN
SCALE: 10X

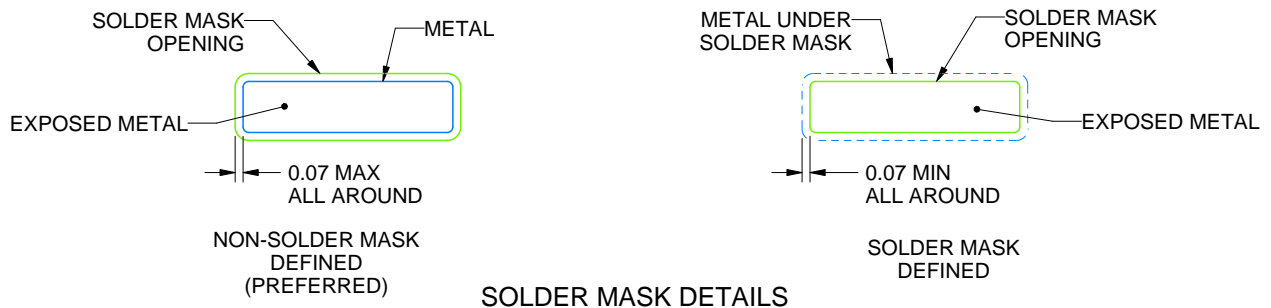

4214851/A 12/2017

NOTES: (continued)

- 6. Publication IPC-7351 may have alternate designs.
- 7. Solder mask tolerances between and around signal pads can vary based on board fabrication site.

EXAMPLE STENCIL DESIGN

DB0020A

TSSOP - 2 mm max height

SMALL OUTLINE PACKAGE

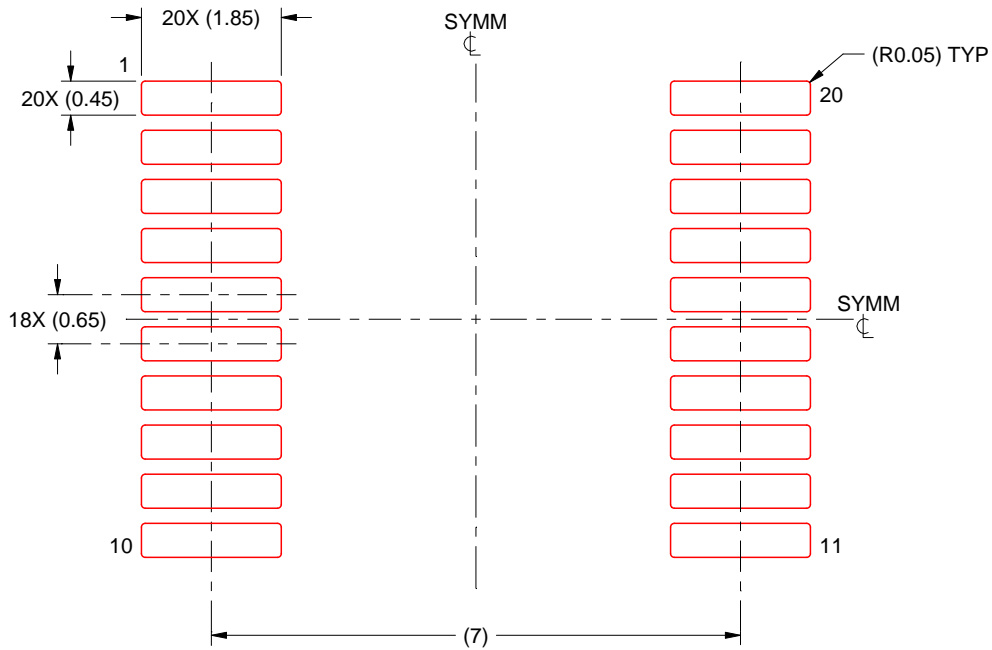

SOLDER PASTE EXAMPLE
BASED ON 0.125 mm THICK STENCIL
SCALE: 10X

4214851/A 12/2017

NOTES: (continued)

8. Laser cutting apertures with trapezoidal walls and rounded corners may offer better paste release. IPC-7525 may have alternate design recommendations.
9. Board assembly site may have different recommendations for stencil design.

DW0020A



PACKAGE OUTLINE

SOIC - 2.65 mm max height

SOIC



4220724/A 05/2016

NOTES:

1. All linear dimensions are in millimeters. Dimensions in parenthesis are for reference only. Dimensioning and tolerancing per ASME Y14.5M.
2. This drawing is subject to change without notice.
3. This dimension does not include mold flash, protrusions, or gate burrs. Mold flash, protrusions, or gate burrs shall not exceed 0.15 mm per side.
4. This dimension does not include interlead flash. Interlead flash shall not exceed 0.43 mm per side.
5. Reference JEDEC registration MS-013.

EXAMPLE BOARD LAYOUT

DW0020A

SOIC - 2.65 mm max height

SOIC



LAND PATTERN EXAMPLE
SCALE:6X



SOLDER MASK DETAILS

4220724/A 05/2016

NOTES: (continued)

- 6. Publication IPC-7351 may have alternate designs.
- 7. Solder mask tolerances between and around signal pads can vary based on board fabrication site.

EXAMPLE STENCIL DESIGN

DW0020A

SOIC - 2.65 mm max height

SOIC

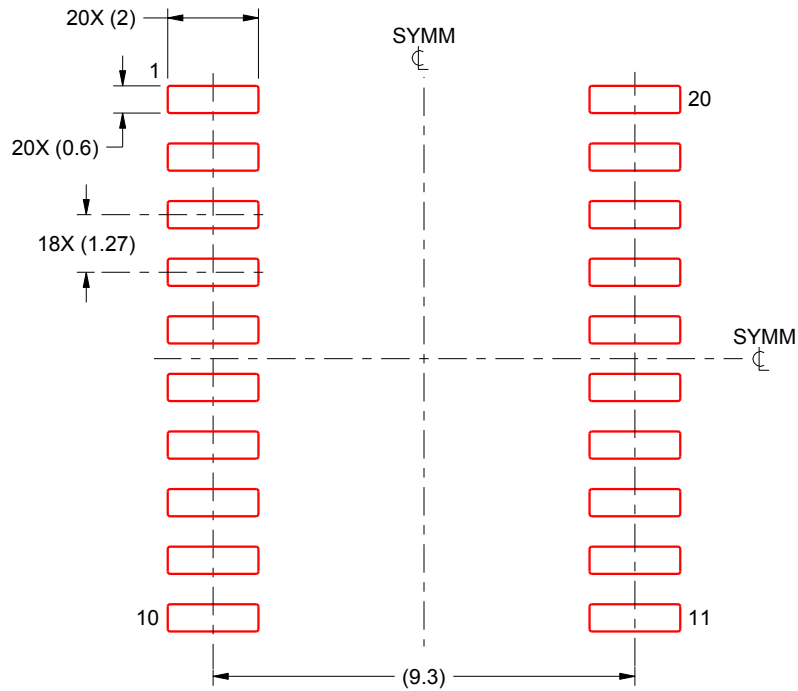

SOLDER PASTE EXAMPLE
BASED ON 0.125 mm THICK STENCIL
SCALE:6X

4220724/A 05/2016

NOTES: (continued)

8. Laser cutting apertures with trapezoidal walls and rounded corners may offer better paste release. IPC-7525 may have alternate design recommendations.
9. Board assembly site may have different recommendations for stencil design.

IMPORTANT NOTICE AND DISCLAIMER

TI PROVIDES TECHNICAL AND RELIABILITY DATA (INCLUDING DATASHEETS), DESIGN RESOURCES (INCLUDING REFERENCE DESIGNS), APPLICATION OR OTHER DESIGN ADVICE, WEB TOOLS, SAFETY INFORMATION, AND OTHER RESOURCES "AS IS" AND WITH ALL FAULTS, AND DISCLAIMS ALL WARRANTIES, EXPRESS AND IMPLIED, INCLUDING WITHOUT LIMITATION ANY IMPLIED WARRANTIES OF MERCHANTABILITY, FITNESS FOR A PARTICULAR PURPOSE OR NON-INFRINGEMENT OF THIRD PARTY INTELLECTUAL PROPERTY RIGHTS.

These resources are intended for skilled developers designing with TI products. You are solely responsible for (1) selecting the appropriate TI products for your application, (2) designing, validating and testing your application, and (3) ensuring your application meets applicable standards, and any other safety, security, or other requirements. These resources are subject to change without notice. TI grants you permission to use these resources only for development of an application that uses the TI products described in the resource. Other reproduction and display of these resources is prohibited. No license is granted to any other TI intellectual property right or to any third party intellectual property right. TI disclaims responsibility for, and you will fully indemnify TI and its representatives against, any claims, damages, costs, losses, and liabilities arising out of your use of these resources.

TI's products are provided subject to TI's Terms of Sale (www.ti.com/legal/termsofsale.html) or other applicable terms available either on ti.com or provided in conjunction with such TI products. TI's provision of these resources does not expand or otherwise alter TI's applicable warranties or warranty disclaimers for TI products.

Mailing Address: Texas Instruments, Post Office Box 655303, Dallas, Texas 75265
Copyright © 2018, Texas Instruments Incorporated

Looking for pricing, stock, or lifecycle information?

Click below to explore more details on WIN SOURCE:

 [View CDC339DB](#) on WIN SOURCE

 [Texas Instruments](#) Information

Optimize Your Supply Chain with WIN SOURCE Solutions

-  Global Sourcing Solution
-  Obsolete Management
-  Cost Control Management
-  Shortage Management
-  Alternative Solution
-  Excess Inventory Management