



THE DATASHEET OF CDC337DWR



CDC337 CLOCK DRIVER WITH 3-STATE OUTPUTS

SCAS330B – DECEMBER 1990 – REVISED OCTOBER 1998

- **Low Output Skew, Low Pulse Skew for Clock-Distribution and Clock-Generation Applications**
- **TTL-Compatible Inputs and CMOS-Compatible Outputs**
- **Distributes One Clock Input to Eight Outputs**
 - Four Same-Frequency Outputs
 - Four Half-Frequency Outputs
- **Distributed V_{CC} and Ground Pins Reduce Switching Noise**
- **High-Drive Outputs ($-48\text{-mA } I_{OH}$, $48\text{-mA } I_{OL}$)**
- **State-of-the-Art EPIC-IIB™ BiCMOS Design Significantly Reduces Power Dissipation**
- **Package Options Include Plastic Small-Outline (DW)**

**DW PACKAGE
(TOP VIEW)**

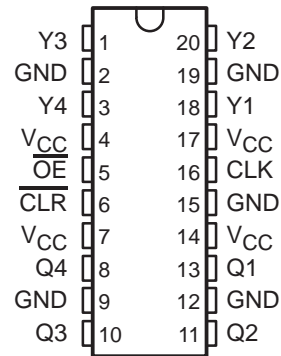

description

The CDC337 is a high-performance, low-skew clock driver. It is specifically designed for applications requiring synchronized output signals at both the clock frequency and one-half the clock frequency. The four Y outputs switch in phase and at the same frequency as the clock (CLK) input. The four Q outputs switch at one-half the frequency of CLK.

When the output-enable (\overline{OE}) input is low and the clear (\overline{CLR}) input is high, the Y outputs follow CLK and the Q outputs toggle on low-to-high transitions at CLK. Taking \overline{CLR} low asynchronously resets the Q outputs to the low level. When \overline{OE} is high, the outputs are in the high-impedance state.

The CDC337 is characterized for operation from -40°C to 85°C .

FUNCTION TABLE

INPUTS			OUTPUTS	
\overline{OE}	\overline{CLR}	CLK	Y1–Y4	Q1–Q4
H	X	X	Z	Z
L	L	L	L	L
L	L	H	H	L
L	H	L	L	Q_0^{\dagger}
L	H	\uparrow	H	$\overline{Q_0}^{\dagger}$

\dagger The level of the Q outputs before the indicated steady-state input conditions were established



Please be aware that an important notice concerning availability, standard warranty, and use in critical applications of Texas Instruments semiconductor products and disclaimers thereto appears at the end of this data sheet.

EPIC-IIB is a trademark of Texas Instruments Incorporated.

PRODUCTION DATA information is current as of publication date. Products conform to specifications per the terms of Texas Instruments standard warranty. Production processing does not necessarily include testing of all parameters.



POST OFFICE BOX 655303 • DALLAS, TEXAS 75265

Copyright © 1998, Texas Instruments Incorporated

CDC337
CLOCK DRIVER
WITH 3-STATE OUTPUTS

SCAS330B – DECEMBER 1990 – REVISED OCTOBER 1998

logic symbol†

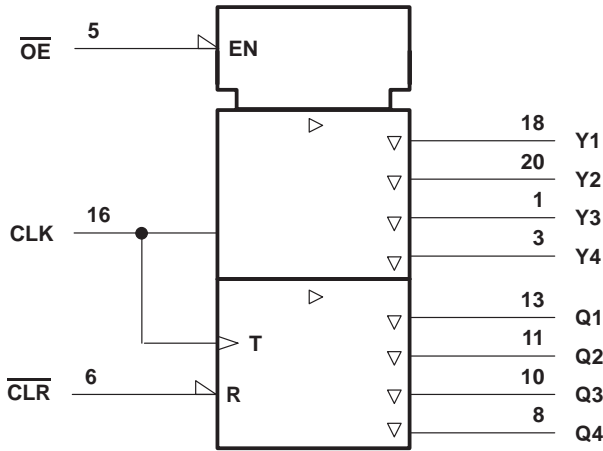

† This symbol is in accordance with ANSI/IEEE Std 91-1984 and IEC Publication 617-12.

logic diagram (positive logic)

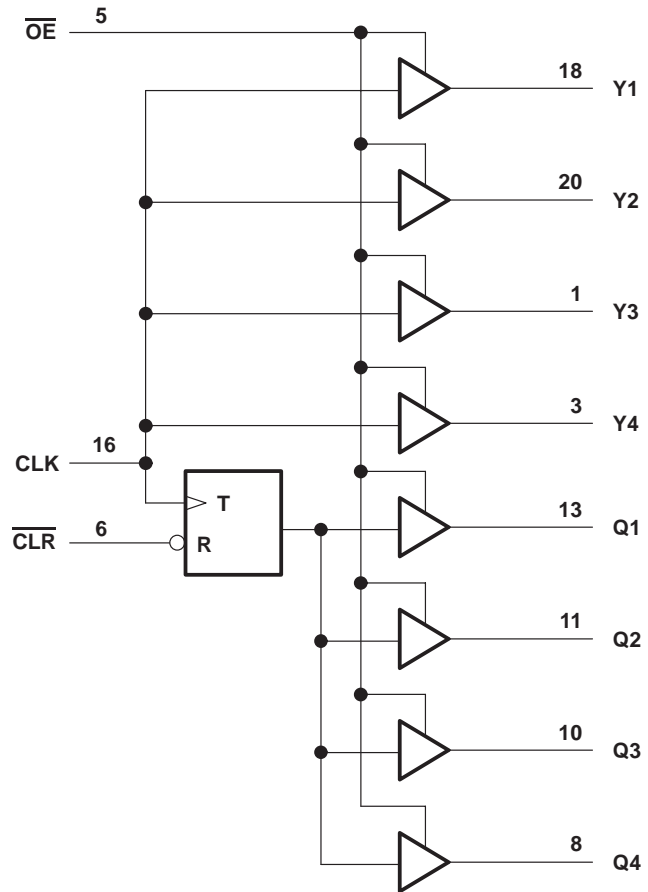

absolute maximum ratings over operating free-air temperature range (unless otherwise noted)‡

Supply voltage range, V_{CC}	-0.5 V to 7 V
Input voltage range, V_I (see Note 1)	-0.5 V to 7 V
Voltage range applied to any output in the high state or power-off state, V_O (see Note 1)	-0.5 V to $V_{CC} + 0.5$ V
Current into any output in the low state, I_O	96 mA
Input clamp current, I_{IK} ($V_I < 0$)	-18 mA
Maximum power dissipation at $T_A = 55^\circ\text{C}$ (in still air) (see Note 2)	1.6 W
Storage temperature range, T_{stg}	-65°C to 150°C

‡ Stresses beyond those listed under "absolute maximum ratings" may cause permanent damage to the device. These are stress ratings only, and functional operation of the device at these or any other conditions beyond those indicated under "recommended operating conditions" is not implied. Exposure to absolute-maximum-rated conditions for extended periods may affect device reliability.

- NOTES: 1. The input and output negative-voltage ratings may be exceeded if the input and output clamp-current ratings are observed.
 2. The maximum package power dissipation is calculated using a junction temperature of 150°C and a board trace length of 750 mils. For more information, refer to the *Package Thermal Considerations* application note in the 1994 *ABT Advanced BiCMOS Technology Data Book*, literature number SCBD002B.

CDC337 CLOCK DRIVER WITH 3-STATE OUTPUTS

SCAS330B – DECEMBER 1990 – REVISED OCTOBER 1998

recommended operating conditions (see Note 3)

		MIN	MAX	UNIT
V_{CC}	Supply voltage	4.75	5.25	V
V_{IH}	High-level input voltage	2		V
V_{IL}	Low-level input voltage		0.8	V
V_I	Input voltage	0	V_{CC}	V
I_{OH}	High-level output current		-48	mA
I_{OL}	Low-level output current		48	mA
f_{clock}	Input clock frequency		80	MHz
T_A	Operating free-air temperature	-40	85	°C

NOTE 3: Unused pins (input or I/O) must be held high or low to prevent them from floating.

electrical characteristics over recommended operating free-air temperature range (unless otherwise noted)

PARAMETER	TEST CONDITIONS		MIN	TYP†	MAX	UNIT
V_{IK}	$V_{CC} = 4.75\text{ V}$,	$I_I = -18\text{ mA}$			-1.2	V
V_{OH}	$V_{CC} = 4.75\text{ V}$,	$I_{OH} = -32\text{ mA}$	3.75			V
V_{OL}	$V_{CC} = 4.75\text{ V}$,	$I_{OL} = 32\text{ mA}$			0.55	V
I_{IH}	$V_{CC} = 5.25\text{ V}$,	$V_I = 2.7\text{ V}$			50	μA
I_{IL}	$V_{CC} = 5.25\text{ V}$,	$V_I = 0.5\text{ V}$			-50	μA
I_{OZ}	$V_{CC} = 5.25\text{ V}$,	$V_O = V_{CC}$ or GND			±50	μA
I_{CC}	$V_{CC} = 5.25\text{ V}$,	$V_I = V_{CC}$ or GND, $I_O = 0$	Outputs high		70	mA
			Outputs low		85	
			Outputs disabled		70	
C_i	$V_I = 2.5\text{ V}$ or 0.5 V			3		pF
C_o	$V_O = V_{CC}$ or GND			10		pF

† All typical values are at $V_{CC} = 5\text{ V}$, $T_A = 25^\circ\text{C}$.

timing requirements over recommended ranges of supply voltage and operating free-air temperature (unless otherwise noted)

		MIN	MAX	UNIT
f_{clock}	Clock frequency		80	MHz
t_w	Pulse duration	$\overline{\text{CLR}}$ low	4	ns
		CLK low	4	
		CLK high	4	
t_{su}	Setup time, $\overline{\text{CLR}}$ inactive before $\text{CLK}\uparrow$	2		ns
	Clock duty cycle	40%	60%	

CDC337
CLOCK DRIVER
WITH 3-STATE OUTPUTS

SCAS330B – DECEMBER 1990 – REVISED OCTOBER 1998

switching characteristics over recommended ranges of supply voltage and operating free-air temperature, $C_L = 50$ pF (unless otherwise noted) (see Note 4 and Figures 1 and 2)

PARAMETER	FROM (INPUT)	TO (OUTPUT)	MIN	TYP†	MAX	UNIT
f_{max}			80			MHz
t_{PLH}	CLK	Any Y or Q	4		9	ns
t_{PHL}			4		9	
t_{PHL}	\overline{CLR}	Any Q	4		10	ns
t_{PZH}	\overline{OE}	Any Y or Q	3		7	ns
t_{PZL}			3		7	
t_{PHZ}	\overline{OE}	Any Y or Q	2		7	ns
t_{PLZ}			2		7	
$t_{sk(o)}$	CLK↑	Y↑			0.75	ns
		Q↑			0.9	
		Y↑ and Q↑			0.9	
t_r				0.9		ns
t_f				0.7		ns

† All typical values are at $V_{CC} = 5$ V, $T_A = 25^\circ\text{C}$.

NOTE 4: All specifications are valid only for all outputs switching.



PARAMETER MEASUREMENT INFORMATION

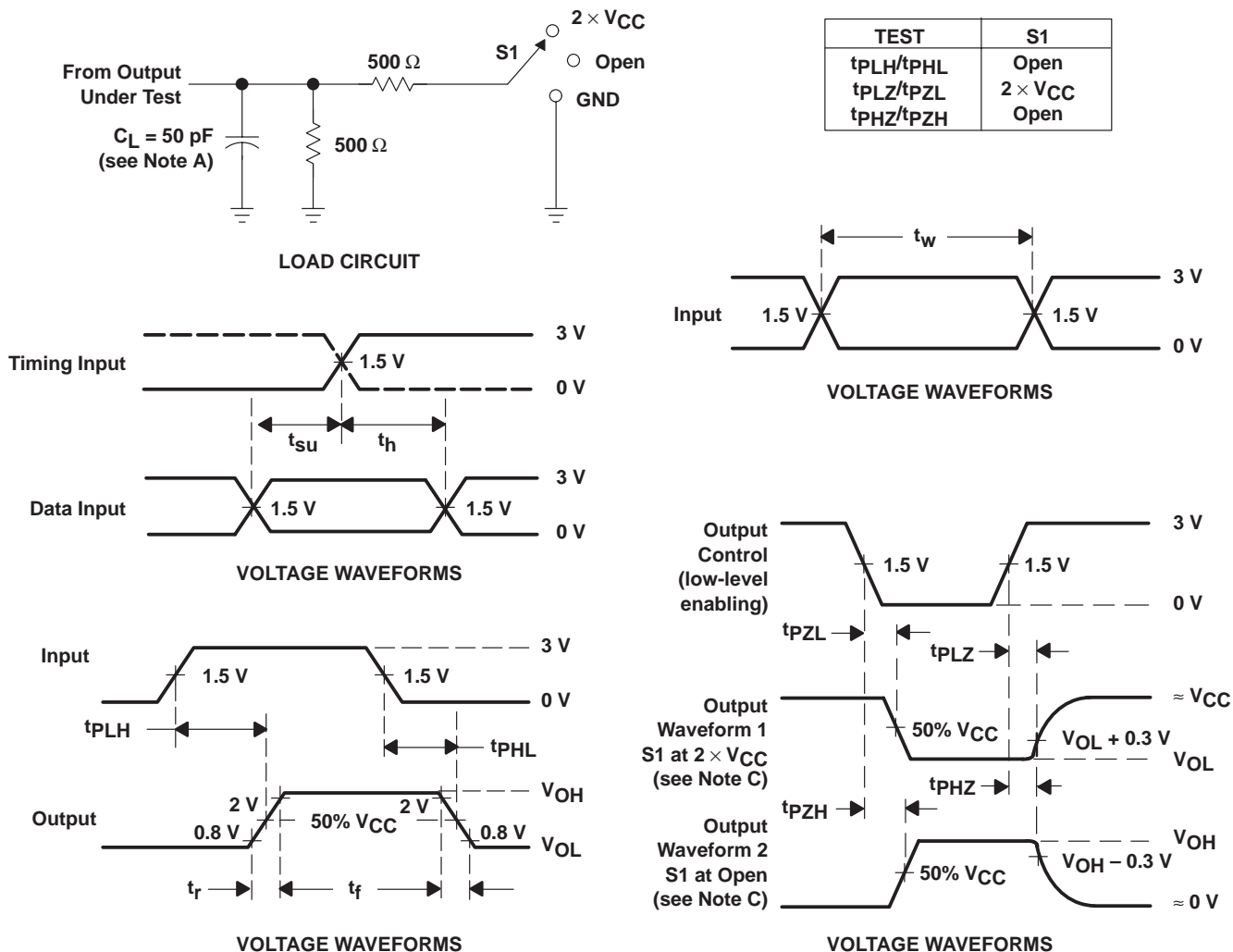

- NOTES: A. C_L includes probe and jig capacitance.
 B. All input pulses are supplied by generators having the following characteristics: $PRR \leq 10 \text{ MHz}$, $Z_O = 50 \Omega$, $t_r \leq 2.5 \text{ ns}$, $t_f \leq 2.5 \text{ ns}$.
 C. Waveform 1 is for an output with internal conditions such that the output is low except when disabled by the output control. Waveform 2 is for an output with internal conditions such that the output is high except when disabled by the output control.
 D. The outputs are measured one at a time with one transition per measurement.

Figure 1. Load Circuit and Voltage Waveforms

**CDC337
CLOCK DRIVER
WITH 3-STATE OUTPUTS**

SCAS330B – DECEMBER 1990 – REVISED OCTOBER 1998

PARAMETER MEASUREMENT INFORMATION

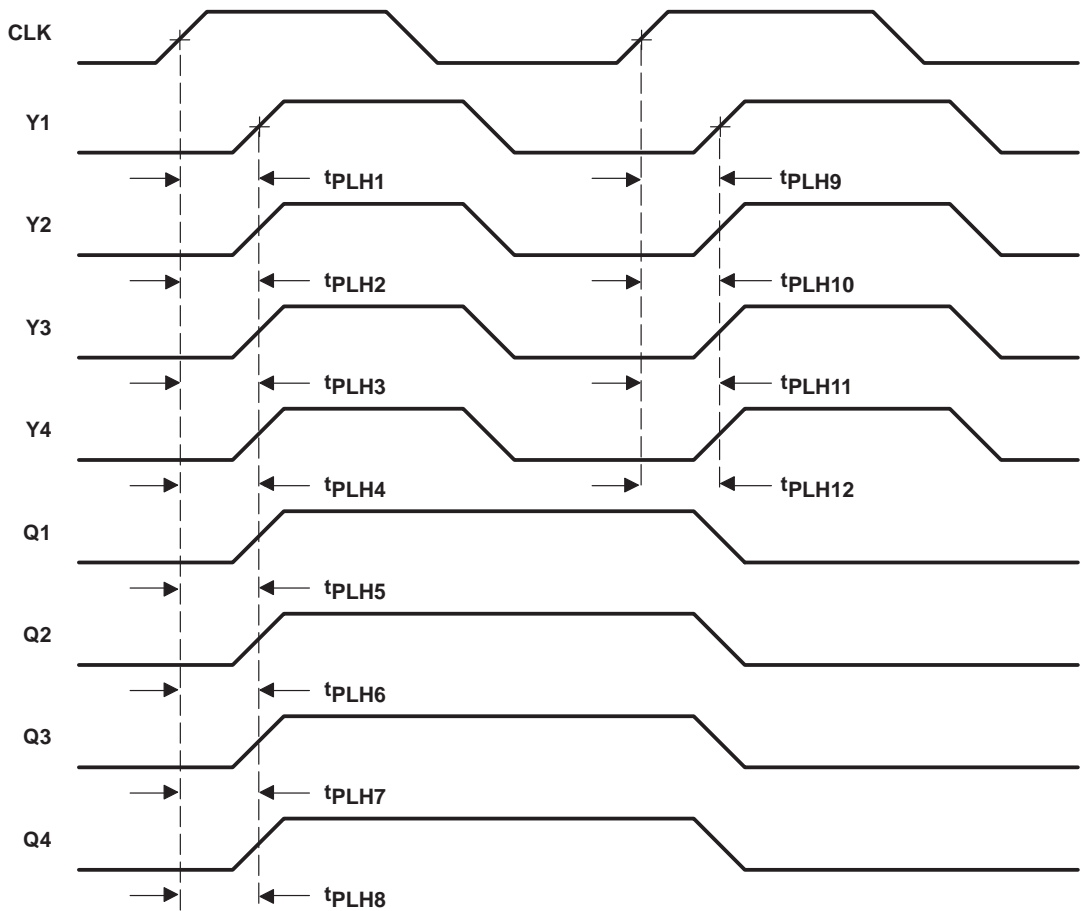

- NOTES: A. Output skew, $t_{sk(o)}$, from $CLK\uparrow$ to $Y\uparrow$, is calculated as the greater of the difference between the fastest and slowest of t_{PLHn} ($n = 1, 2, 3, 4$) or t_{PLHn} ($n = 9, 10, 11, 12$).
- B. Output skew, $t_{sk(o)}$, from $CLK\uparrow$ to $Q\uparrow$, is calculated as the greater of the difference between the fastest and slowest of t_{PLHn} ($n = 5, 6, 7, 8$).
- C. Output skew, $t_{sk(o)}$, from $CLK\uparrow$ to $Y\uparrow$ and $Q\uparrow$, is calculated as the greater of the difference between the fastest and slowest of t_{PLHn} ($n = 1, 2, \dots, 8$).

Figure 2. Waveforms for Calculation of $t_{sk(o)}$



CDC337
CLOCK DRIVER
WITH 3-STATE OUTPUTS

SCAS330B – DECEMBER 1990 – REVISED OCTOBER 1998

MECHANICAL INFORMATION

DW (R-PDSO-G**)

PLASTIC SMALL-OUTLINE PACKAGE

16 PIN SHOWN

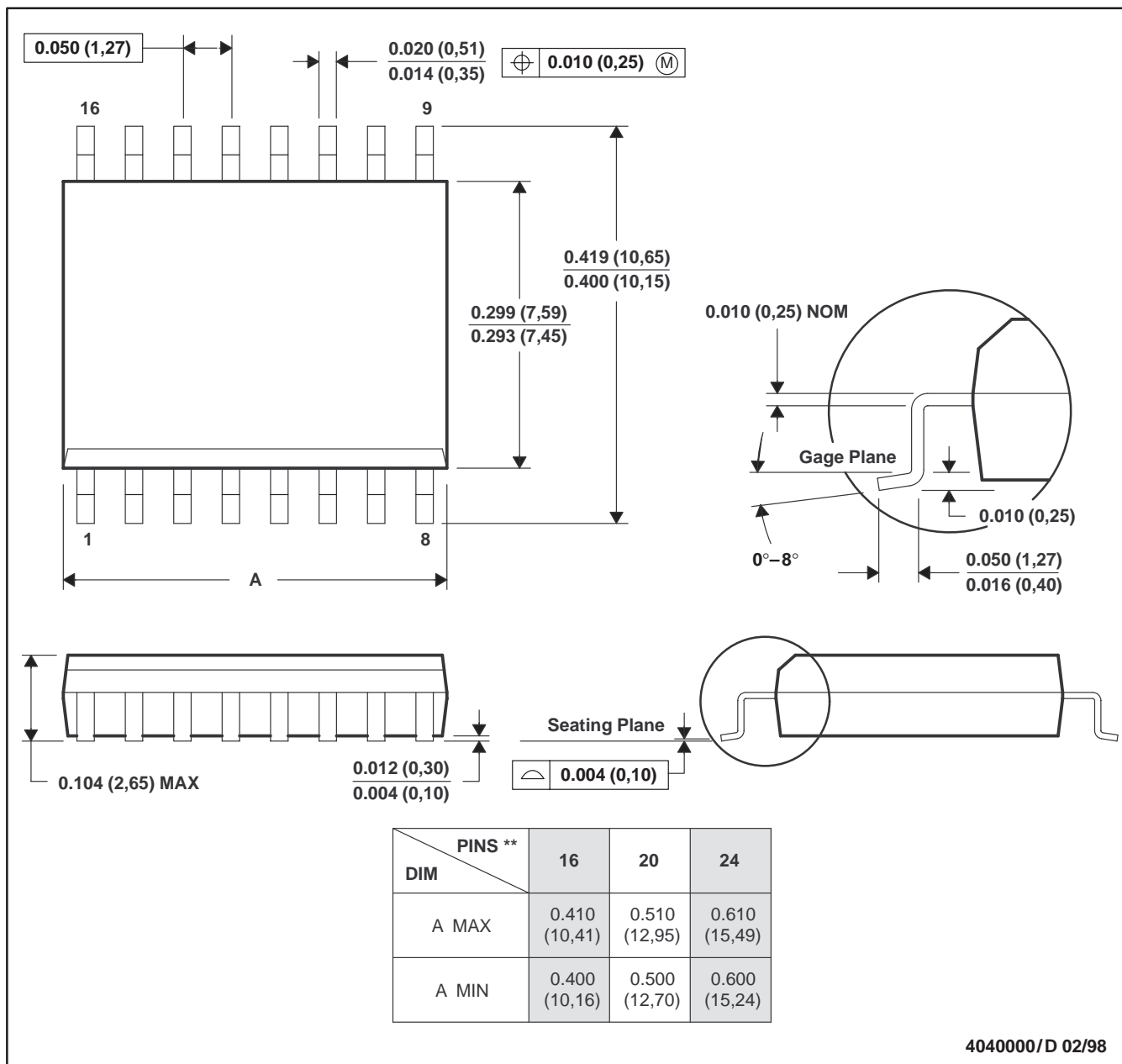

- NOTES: A. All linear dimensions are in inches (millimeters).
 B. This drawing is subject to change without notice.
 C. Body dimensions do not include mold flash or protrusion not to exceed 0.006 (0,15).
 D. Falls within JEDEC MS-013

PACKAGING INFORMATION

Orderable Device	Status (1)	Package Type	Package Drawing	Pins	Package Qty	Eco Plan (2)	Lead/Ball Finish (6)	MSL Peak Temp (3)	Op Temp (°C)	Device Marking (4/5)	Samples
CDC337DW	ACTIVE	SOIC	DW	20	25	Green (RoHS & no Sb/Br)	CU NIPDAU	Level-1-260C-UNLIM	-40 to 85	CDC337	Samples
CDC337DWG4	ACTIVE	SOIC	DW	20	25	Green (RoHS & no Sb/Br)	CU NIPDAU	Level-1-260C-UNLIM	-40 to 85	CDC337	Samples

(1) The marketing status values are defined as follows:

ACTIVE: Product device recommended for new designs.

LIFEBUY: TI has announced that the device will be discontinued, and a lifetime-buy period is in effect.

NRND: Not recommended for new designs. Device is in production to support existing customers, but TI does not recommend using this part in a new design.

PREVIEW: Device has been announced but is not in production. Samples may or may not be available.

OBSOLETE: TI has discontinued the production of the device.

(2) Eco Plan - The planned eco-friendly classification: Pb-Free (RoHS), Pb-Free (RoHS Exempt), or Green (RoHS & no Sb/Br) - please check <http://www.ti.com/productcontent> for the latest availability information and additional product content details.

TBD: The Pb-Free/Green conversion plan has not been defined.

Pb-Free (RoHS): TI's terms "Lead-Free" or "Pb-Free" mean semiconductor products that are compatible with the current RoHS requirements for all 6 substances, including the requirement that lead not exceed 0.1% by weight in homogeneous materials. Where designed to be soldered at high temperatures, TI Pb-Free products are suitable for use in specified lead-free processes.

Pb-Free (RoHS Exempt): This component has a RoHS exemption for either 1) lead-based flip-chip solder bumps used between the die and package, or 2) lead-based die adhesive used between the die and leadframe. The component is otherwise considered Pb-Free (RoHS compatible) as defined above.

Green (RoHS & no Sb/Br): TI defines "Green" to mean Pb-Free (RoHS compatible), and free of Bromine (Br) and Antimony (Sb) based flame retardants (Br or Sb do not exceed 0.1% by weight in homogeneous material)

(3) MSL, Peak Temp. - The Moisture Sensitivity Level rating according to the JEDEC industry standard classifications, and peak solder temperature.

(4) There may be additional marking, which relates to the logo, the lot trace code information, or the environmental category on the device.

(5) Multiple Device Markings will be inside parentheses. Only one Device Marking contained in parentheses and separated by a "~" will appear on a device. If a line is indented then it is a continuation of the previous line and the two combined represent the entire Device Marking for that device.

(6) Lead/Ball Finish - Orderable Devices may have multiple material finish options. Finish options are separated by a vertical ruled line. Lead/Ball Finish values may wrap to two lines if the finish value exceeds the maximum column width.

Important Information and Disclaimer: The information provided on this page represents TI's knowledge and belief as of the date that it is provided. TI bases its knowledge and belief on information provided by third parties, and makes no representation or warranty as to the accuracy of such information. Efforts are underway to better integrate information from third parties. TI has taken and continues to take reasonable steps to provide representative and accurate information but may not have conducted destructive testing or chemical analysis on incoming materials and chemicals. TI and TI suppliers consider certain information to be proprietary, and thus CAS numbers and other limited information may not be available for release.

In no event shall TI's liability arising out of such information exceed the total purchase price of the TI part(s) at issue in this document sold by TI to Customer on an annual basis.

IMPORTANT NOTICE

Texas Instruments Incorporated (TI) reserves the right to make corrections, enhancements, improvements and other changes to its semiconductor products and services per JESD46, latest issue, and to discontinue any product or service per JESD48, latest issue. Buyers should obtain the latest relevant information before placing orders and should verify that such information is current and complete.

TI's published terms of sale for semiconductor products (<http://www.ti.com/sc/docs/stdterms.htm>) apply to the sale of packaged integrated circuit products that TI has qualified and released to market. Additional terms may apply to the use or sale of other types of TI products and services.

Reproduction of significant portions of TI information in TI data sheets is permissible only if reproduction is without alteration and is accompanied by all associated warranties, conditions, limitations, and notices. TI is not responsible or liable for such reproduced documentation. Information of third parties may be subject to additional restrictions. Resale of TI products or services with statements different from or beyond the parameters stated by TI for that product or service voids all express and any implied warranties for the associated TI product or service and is an unfair and deceptive business practice. TI is not responsible or liable for any such statements.

Buyers and others who are developing systems that incorporate TI products (collectively, "Designers") understand and agree that Designers remain responsible for using their independent analysis, evaluation and judgment in designing their applications and that Designers have full and exclusive responsibility to assure the safety of Designers' applications and compliance of their applications (and of all TI products used in or for Designers' applications) with all applicable regulations, laws and other applicable requirements. Designer represents that, with respect to their applications, Designer has all the necessary expertise to create and implement safeguards that (1) anticipate dangerous consequences of failures, (2) monitor failures and their consequences, and (3) lessen the likelihood of failures that might cause harm and take appropriate actions. Designer agrees that prior to using or distributing any applications that include TI products, Designer will thoroughly test such applications and the functionality of such TI products as used in such applications.

TI's provision of technical, application or other design advice, quality characterization, reliability data or other services or information, including, but not limited to, reference designs and materials relating to evaluation modules, (collectively, "TI Resources") are intended to assist designers who are developing applications that incorporate TI products; by downloading, accessing or using TI Resources in any way, Designer (individually or, if Designer is acting on behalf of a company, Designer's company) agrees to use any particular TI Resource solely for this purpose and subject to the terms of this Notice.

TI's provision of TI Resources does not expand or otherwise alter TI's applicable published warranties or warranty disclaimers for TI products, and no additional obligations or liabilities arise from TI providing such TI Resources. TI reserves the right to make corrections, enhancements, improvements and other changes to its TI Resources. TI has not conducted any testing other than that specifically described in the published documentation for a particular TI Resource.

Designer is authorized to use, copy and modify any individual TI Resource only in connection with the development of applications that include the TI product(s) identified in such TI Resource. NO OTHER LICENSE, EXPRESS OR IMPLIED, BY ESTOPPEL OR OTHERWISE TO ANY OTHER TI INTELLECTUAL PROPERTY RIGHT, AND NO LICENSE TO ANY TECHNOLOGY OR INTELLECTUAL PROPERTY RIGHT OF TI OR ANY THIRD PARTY IS GRANTED HEREIN, including but not limited to any patent right, copyright, mask work right, or other intellectual property right relating to any combination, machine, or process in which TI products or services are used. Information regarding or referencing third-party products or services does not constitute a license to use such products or services, or a warranty or endorsement thereof. Use of TI Resources may require a license from a third party under the patents or other intellectual property of the third party, or a license from TI under the patents or other intellectual property of TI.

TI RESOURCES ARE PROVIDED "AS IS" AND WITH ALL FAULTS. TI DISCLAIMS ALL OTHER WARRANTIES OR REPRESENTATIONS, EXPRESS OR IMPLIED, REGARDING RESOURCES OR USE THEREOF, INCLUDING BUT NOT LIMITED TO ACCURACY OR COMPLETENESS, TITLE, ANY EPIDEMIC FAILURE WARRANTY AND ANY IMPLIED WARRANTIES OF MERCHANTABILITY, FITNESS FOR A PARTICULAR PURPOSE, AND NON-INFRINGEMENT OF ANY THIRD PARTY INTELLECTUAL PROPERTY RIGHTS. TI SHALL NOT BE LIABLE FOR AND SHALL NOT DEFEND OR INDEMNIFY DESIGNER AGAINST ANY CLAIM, INCLUDING BUT NOT LIMITED TO ANY INFRINGEMENT CLAIM THAT RELATES TO OR IS BASED ON ANY COMBINATION OF PRODUCTS EVEN IF DESCRIBED IN TI RESOURCES OR OTHERWISE. IN NO EVENT SHALL TI BE LIABLE FOR ANY ACTUAL, DIRECT, SPECIAL, COLLATERAL, INDIRECT, PUNITIVE, INCIDENTAL, CONSEQUENTIAL OR EXEMPLARY DAMAGES IN CONNECTION WITH OR ARISING OUT OF TI RESOURCES OR USE THEREOF, AND REGARDLESS OF WHETHER TI HAS BEEN ADVISED OF THE POSSIBILITY OF SUCH DAMAGES.

Unless TI has explicitly designated an individual product as meeting the requirements of a particular industry standard (e.g., ISO/TS 16949 and ISO 26262), TI is not responsible for any failure to meet such industry standard requirements.

Where TI specifically promotes products as facilitating functional safety or as compliant with industry functional safety standards, such products are intended to help enable customers to design and create their own applications that meet applicable functional safety standards and requirements. Using products in an application does not by itself establish any safety features in the application. Designers must ensure compliance with safety-related requirements and standards applicable to their applications. Designer may not use any TI products in life-critical medical equipment unless authorized officers of the parties have executed a special contract specifically governing such use. Life-critical medical equipment is medical equipment where failure of such equipment would cause serious bodily injury or death (e.g., life support, pacemakers, defibrillators, heart pumps, neurostimulators, and implantables). Such equipment includes, without limitation, all medical devices identified by the U.S. Food and Drug Administration as Class III devices and equivalent classifications outside the U.S.

TI may expressly designate certain products as completing a particular qualification (e.g., Q100, Military Grade, or Enhanced Product). Designers agree that it has the necessary expertise to select the product with the appropriate qualification designation for their applications and that proper product selection is at Designers' own risk. Designers are solely responsible for compliance with all legal and regulatory requirements in connection with such selection.

Designer will fully indemnify TI and its representatives against any damages, costs, losses, and/or liabilities arising out of Designer's non-compliance with the terms and provisions of this Notice.

Looking for pricing, stock, or lifecycle information?

Click below to explore more details on WIN SOURCE:

 [View CDC337DWR](#) on WIN SOURCE

 [Texas Instruments](#) Information

Optimize Your Supply Chain with WIN SOURCE Solutions

-  Global Sourcing Solution
-  Obsolete Management
-  Cost Control Management
-  Shortage Management
-  Alternative Solution
-  Excess Inventory Management