



**THE DATASHEET OF
CD74HCT4051M96**



CDx4HC405x, CDx4HCT405x High-Speed CMOS Logic Analog Multiplexers and Demultiplexers

1 Features

- Wide Analog Input Voltage Range: ± 5 -V Maximum
- Low ON-Resistance
 - 70- Ω Typical ($V_{CC} - V_{EE} = 4.5$ V)
 - 40- Ω Typical ($V_{CC} - V_{EE} = 9$ V)
- Low Crosstalk Between Switches
- Fast Switching and Propagation Speeds
- Break-Before-Make Switching
- Wide Operating Temperature Range: -55°C to $+125^{\circ}\text{C}$
- CD54HC and CD74HC Types
 - Operation Control Voltage: 2 V to 6 V
 - Switch Voltage: 0 V to 10 V
- CD54HCT and CD74HCT Types
 - Operation Control Voltage: 4.5 V to 5.5 V
 - Switch Voltage: 0 V to 10 V
 - Direct LSTTL Input Logic Compatibility
 $V_{IL} = 0.8$ -V Max, $V_{IH} = 2$ -V Min
 - CMOS Input Compatibility
 $I_I \leq 1$ μA at V_{OL} , V_{OH}
- On Products Compliant to MIL-PRF-38535, All Parameters Are Tested Unless Otherwise Noted. On All Other Products, Production Processing Does Not Necessarily Include Testing of All Parameters.

2 Applications

- Digital Radio
- Signal Gating
- Factory Automation
- Televisions
- Appliances
- Programmable Logic Circuits
- Sensors

3 Description

The CDx4HC405x and CDx4HCT405x devices are digitally controlled analog switches that use silicon gate CMOS technology to achieve operating speeds similar to LSTTL with the low-power consumption of standard CMOS integrated circuits.

These analog multiplexers and demultiplexers control analog voltages that may vary across the voltage supply range (for example, V_{CC} to V_{EE}). They are bidirectional switches that allow any analog input to be used as an output and vice versa. The switches have low ON resistance and low OFF leakages. In addition, all these devices have an enable control that, when high, disables all switches to their OFF state.

Device Information⁽¹⁾

PART NUMBER	PACKAGE	BODY SIZE (NOM)
CD54HCx405xF	CDIP (16)	19.56 mm x 6.92 mm
CD74HCx405xE	PDIP (16)	19.30 mm x 6.35 mm
CD74HCx405xM	SOIC (16)	9.90 mm x 3.91 mm
CD74HCx405xNS	SOP (16)	10.30 mm x 5.30 mm
CD74HCx405xPW	TSSOP (16)	5.00 mm x 4.40 mm

(1) For all available packages, see the orderable addendum at the end of the data sheet.

Functional Diagram of HC4051 and HCT4051

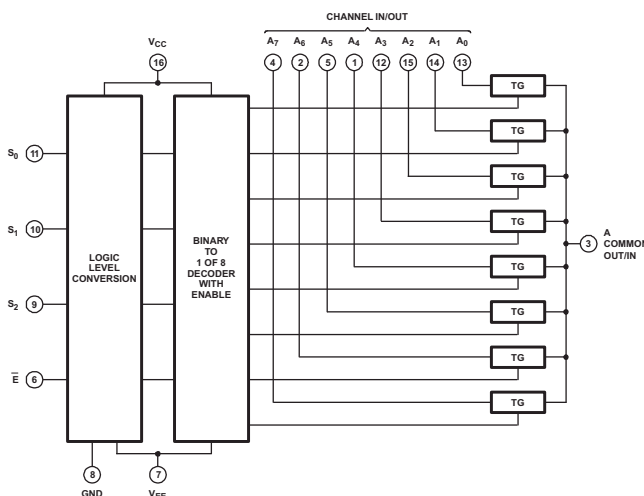

Table of Contents

1 Features	1	8.2 Functional Block Diagrams	20
2 Applications	1	8.3 Feature Description	22
3 Description	1	8.4 Device Functional Modes	22
4 Revision History	2	9 Application and Implementation	23
5 Pin Configuration and Functions	3	9.1 Application Information	23
6 Specifications	6	9.2 Typical Application	23
6.1 Absolute Maximum Ratings	6	10 Power Supply Recommendations	24
6.2 ESD Ratings	6	11 Layout	25
6.3 Recommended Operating Conditions	6	11.1 Layout Guidelines	25
6.4 Thermal Information	7	11.2 Layout Example	25
6.5 Electrical Characteristics: HC Devices	7	12 Device and Documentation Support	26
6.6 Electrical Characteristics: HCT Devices	10	12.1 Documentation Support	26
6.7 Switching Characteristics, $V_{CC} = 5\text{ V}$	12	12.2 Related Links	26
6.8 Switching Characteristics, $C_L = 50\text{ pF}$	13	12.3 Receiving Notification of Documentation Updates	26
6.9 Analog Channel Specifications	16	12.4 Community Resources	26
6.10 Typical Characteristics	17	12.5 Trademarks	26
7 Parameter Measurement Information	18	12.6 Electrostatic Discharge Caution	26
8 Detailed Description	20	12.7 Glossary	27
8.1 Overview	20	13 Mechanical, Packaging, and Orderable Information	27

4 Revision History

NOTE: Page numbers for previous revisions may differ from page numbers in the current version.

Changes from Revision L (February 2017) to Revision M	Page
• Changed <i>Feature</i> From: 7- Ω Typical To: 70- Ω Typical	1

Changes from Revision K (September 2015) to Revision L	Page
• Changed Charged device model (CDM) value from: $\pm 1000\text{ V}$ to: $\pm 200\text{ V}$	6
• Added <i>Receiving Notification of Documentation Updates</i> section	26

Changes from Revision J (February 2011) to Revision K	Page
• Removed <i>Ordering Information</i> table.	1
• Added <i>Device Information</i> table, <i>Pin Functions</i> table, <i>ESD Ratings</i> table, <i>Thermal Information</i> table, <i>Detailed Description</i> section, <i>Applications and Implementation</i> section, <i>Power Supply Recommendations</i> section, <i>Layout</i> section, <i>Device and Documentation Support</i> section, and <i>Mechanical, Packaging, and Orderable Information</i> section	1
• Added Military Disclaimer to <i>Features</i> list.	1

5 Pin Configuration and Functions

CD54HC4051, CD54HCT4051, CD74HC4051, CD74HCT4051 J, N, D, NS, PW Packages
16-Pin CDIP, PDIP, SOIC, SO, TSSOP

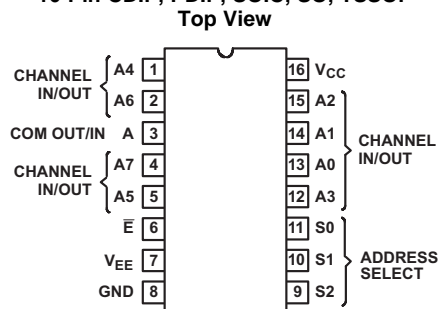

Pin Functions for CDx4HCx4051B

PIN		I/O	DESCRIPTION
NO.	NAME		
1	CH A4 IN/OUT	I/O	Channel 4 in/out
2	CH A6 IN/OUT	I/O	Channel 6 in/out
3	COM OUT/IN	I/O	Common out/in
4	CH A7 IN/OUT	I/O	Channel 7 in/out
5	CH A5 IN/OUT	I/O	Channel 5 in/out
6	\bar{E}	I	Enable Channels (Active Low). See Table 1 .
7	V_{EE}	—	Negative power input
8	GND	—	Ground
9	S2	I	Channel select 2. See Table 1 .
10	S1	I	Channel select 1. See Table 1 .
11	S0	I	Channel select 0. See Table 1 .
12	CH A3 IN/OUT	I/O	Channel 3 in/out
13	CH A0 IN/OUT	I/O	Channel 0 in/out
14	CH A1 IN/OUT	I/O	Channel 1 in/out
15	CH A2 IN/OUT	I/O	Channel 2 in/out
16	V_{CC}	—	Positive power input

CD54HC4052, CD74HC4052, CD74HCT4052 J, N, D, NS, PW Packages
 16-Pin CDIP, PDIP, SOIC, SO, TSSOP
 Top View

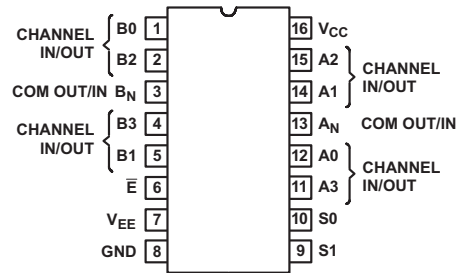

Pin Functions for CDx4HCx4052B

PIN		I/O	DESCRIPTION
NO.	NAME		
1	CH B0 IN/OUT	I/O	Channel B0 in/out
2	CH B2 IN/OUT	I/O	Channel B2 in/out
3	COM B OUT/IN	I/O	B common out/in
4	CH B3 IN/OUT	I/O	Channel B3 in/out
5	CH B1 IN/OUT	I/O	Channel B1 in/out
6	\bar{E}	I	Enable channels (Active Low). See Table 2 .
7	V_{EE}	—	Negative power input
8	GND	—	Ground
9	S1	I	Channel select 1. See Table 2 .
10	S0	I	Channel select 0. See Table 2 .
11	CH A3 IN/OUT	I/O	Channel A3 in/out
12	CH A0 IN/OUT	I/O	Channel A0 in/out
13	COM A IN/OUT	I/O	A common out/in
14	CH A1 IN/OUT	I/O	Channel A1 in/out
15	CH A2 IN/OUT	I/O	Channel A2 in/out
16	V_{CC}	—	Positive power input

**CD54HC4053 CD74HC4053 CD74HCT4053 J, N, D, NS, PW Packages
16-Pin CDIP, PDIP, SOIC, SOP, TSSOP
TOP VIEW**

Pin Functions CDx4HCx4053B

PIN		I/O	DESCRIPTION
NO.	NAME		
1	B1 IN/OUT	I/O	B channel Y in/out
2	B0 IN/OUT	I/O	B channel X in/out
3	C1 IN/OUT	I/O	C channel Y in/out
4	COM C OUT/IN	I/O	C common out/in
5	C0 IN/OUT	I/O	C channel X in/out
6	\bar{E}	I	Enable channels (Active Low). See Table 3 .
7	V_{EE}	—	Negative power input
8	GND	—	Ground
9	S2	I	Channel select 2. See Table 3 .
10	S1	I	Channel select 1. See Table 3 .
11	S0	I	Channel select 0. See Table 3 .
12	A0 IN/OUT	I/O	A channel X in/out
13	A1 IN/OUT	I/O	A channel Y in/out
14	COM A OUT/IN	I/O	A common out/in
15	COM B OUT/IN	I/O	B common out/in
16	V_{CC}	—	Positive power input

6 Specifications

6.1 Absolute Maximum Ratings

over operating free-air temperature range (unless otherwise noted)⁽¹⁾

		MIN	MAX	UNIT
$V_{CC} - V_{EE}$	DC supply voltage	-0.5	10.5	V
V_{CC}	DC supply voltage	-0.5	7	V
V_{EE}	DC supply voltage	0.5	-7	V
I_{IK}	DC input diode current	$V_I < -0.5\text{ V}$ or $V_I > V_{CC} + 0.5\text{ V}$		±20 mA
I_{OK}	DC switch diode current	$V_I < V_{EE} - 0.5\text{ V}$ or $V_I > V_{CC} + 0.5\text{ V}$		±20 mA
	DC switch current ⁽²⁾	$V_I > V_{EE} - 0.5\text{ V}$ or $V_I < V_{CC} + 0.5\text{ V}$		±25 mA
I_{CC}	DC V_{CC} or ground current		±50	mA
I_{EE}	DC V_{EE} current		-20	mA
T_{JMAX}	Maximum junction temperature		150	°C
T_{LMAX}	Maximum lead temperature	Soldering 10 s		300 °C
T_J	Junction temperature		150	°C
T_{stg}	Storage temperature	-65	150	°C

- (1) Stresses beyond those listed under *Absolute Maximum Ratings* may cause permanent damage to the device. These are stress ratings only, and functional operation of the device at these or any other conditions beyond those indicated under *Recommended Operating Conditions* is not implied. Exposure to absolute-maximum-rated conditions for extended periods may affect device reliability.
- (2) All voltages referenced to GND unless otherwise specified.

6.2 ESD Ratings

		VALUE	UNIT
$V_{(ESD)}$	Electrostatic discharge	Human body model (HBM), per ANSI/ESDA/JEDEC JS-001 ⁽¹⁾	±500
		Charged device model (CDM), per JEDEC specification JESD22-C101 or ANSI/ESDA/JEDEC JS-002 ⁽²⁾	±200

- (1) JEDEC document JEP155 states that 500-V HBM allows safe manufacturing with a standard ESD control process.
- (2) JEDEC document JEP157 states that 250-V CDM allows safe manufacturing with a standard ESD control process.

6.3 Recommended Operating Conditions

over operating free-air temperature range (unless otherwise noted)⁽¹⁾

			MIN	NOM	MAX	UNIT
V_{CC}	Supply voltage range (T_A = full package temperature range) ⁽²⁾	CD54 and 74HC types	2		6	V
		CD54 and 74HCT types	4.5		5.5	
$V_{CC} - V_{EE}$	Supply voltage range (T_A = full package temperature range)	CD54 and 74HC types, CD54 and 74HCT types (see Figure 1)	2		10	V
V_{EE}	Supply voltage range (T_A = full package temperature range) ⁽³⁾	CD54 and 74HC types, CD54 and 74HCT types (see Figure 2)	0		-6	V
V_I	DC input control voltage		GND		V_{CC}	V
V_{IS}	Analog switch I/O voltage		V_{EE}		V_{CC}	V
T_A	Operating temperature		-55		125	°C
t_r, t_f	Input rise and fall times	2 V	0		1000	ns
		4.5 V	0		500	
		6 V	0		400	

- (1) For maximum reliability, nominal operating conditions must be selected so that operation is always within the ranges specified in the *Recommended Operating Conditions* table.
- (2) All voltages referenced to GND unless otherwise specified.
- (3) In certain applications, the external load resistor current may include both V_{CC} and signal line components. To avoid drawing V_{CC} current when switch current flows into the transmission gate inputs, the voltage drop across the bidirectional switch must not exceed 0.6 V (calculated from r_{ON} values shown in [Electrical Characteristics: HC Devices](#) and [Electrical Characteristics: HCT Devices](#) tables). No V_{CC} current will flow through R_L if the switch current flows into terminal 3 on the HC and HCT4051; terminals 3 and 13 on the HC and HCT4052; terminals 4, 14, and 15 on the HC and HCT4053.

6.4 Thermal Information

THERMAL METRIC ⁽¹⁾		CD74HC4051			UNIT
		N (PDIP)	NS (SO)	PW (TSSOP)	
		16 PINS	16 PINS	16 PINS	
$R_{\theta JA}$	Junction-to-ambient thermal resistance	49.0	83.0	107.7	°C/W
$R_{\theta JC(top)}$	Junction-to-case (top) thermal resistance	36.3	41.2	42.4	°C/W
$R_{\theta JB}$	Junction-to-board thermal resistance	29.0	43.3	52.8	°C/W
Ψ_{JT}	Junction-to-top characterization parameter	21.2	9.2	4.2	°C/W
Ψ_{JB}	Junction-to-board characterization parameter	28.9	43.0	52.2	°C/W

(1) For more information about traditional and new thermal metrics, see the [Semiconductor and IC Package Thermal Metrics](#) application report.

6.5 Electrical Characteristics: HC Devices

PARAMETERS	TEST CONDITIONS					MIN	TYP	MAX	UNIT
	V_{IS} (V)	V_I (V)	V_{EE} (V)	V_{CC} (V)	T_A				
V_{IH} High-level input voltage				2	25°C	1.5			V
					-40°C to +85°C	1.5			
					-55°C to +125°C	1.5			
					25°C	3.15			
					-40°C to +85°C	3.15			
					-55°C to +125°C	3.15			
					25°C	4.2			
					-40°C to +85°C	4.2			
					-55°C to +125°C	4.2			
V_{IL} Low-level input voltage				2	25°C		0.5		V
					-40°C to +85°C		0.5		
					-55°C to +125°C		0.5		
					25°C		1.35		
					-40°C to +85°C		1.35		
					-55°C to +125°C		1.35		
					25°C		1.8		
					-40°C to +85°C		1.8		
					-55°C to +125°C		1.8		

Electrical Characteristics: HC Devices (continued)

PARAMETERS		TEST CONDITIONS					MIN	TYP	MAX	UNIT
		V _{IS} (V)	V _I (V)	V _{EE} (V)	V _{CC} (V)	T _A				
r _{ON}	ON resistance	I _O = 1 mA See Figure 21	V _{CC} or V _{EE}	V _{IL} or V _{IH}	0	4.5	25°C	70	160	Ω
							-40°C to +85°C		200	
							-55°C to +125°C		240	
					0	6	25°C	60	140	
							-40°C to +85°C		175	
							-55°C to +125°C		210	
			-4.5	4.5	25°C	40	120			
					-40°C to +85°C		150			
					-55°C to +125°C		180			
			V _{CC} to V _{EE}	V _{IL} or V _{IH}	0	4.5	25°C	90	180	
							-40°C to +85°C		225	
							-55°C to +125°C		270	
0	6	25°C			80	160				
		-40°C to +85°C				200				
		-55°C to +125°C				240				
-4.5	4.5	25°C	45	130						
		-40°C to +85°C		162						
		-55°C to +125°C		195						
Δr _{ON}	Maximum ON resistance between any two channels			0	4.5	25°C	10	Ω		
				0	6	25°C	8.5			
				-4.5	4.5	25°C	5			

Electrical Characteristics: HC Devices (continued)

PARAMETERS		TEST CONDITIONS					MIN	TYP	MAX	UNIT
		V_{IS} (V)	V_I (V)	V_{EE} (V)	V_{CC} (V)	T_A				
I_{IZ}	1 and 2 channels	For switch OFF: When $V_{IS} = V_{CC}$, $V_{OS} = V_{EE}$; When $V_{IS} = V_{EE}$, $V_{OS} = V_{CC}$. For switch ON: All applicable combinations of V_{IS} and V_{OS} voltage levels	V_{IL} or V_{IH}	0	6	25°C		±0.1	μA	
						-40°C to +85°C		±1		
						-55°C to +125°C		±1		
	4053			-5	5	25°C		±0.1		
						-40°C to +85°C		±1		
						-55°C to +125°C		±1		
	4 channels			0	6	25°C		±0.1		
						-40°C to +85°C		±1		
						-55°C to +125°C		±1		
	4052			-5	5	25°C		±0.2		
						-40°C to +85°C		±2		
						-55°C to +125°C		±2		
8 channels	0	6	25°C		±0.2					
			-40°C to +85°C		±2					
			-55°C to +125°C		±2					
4051	-5	5	25°C		±0.4					
			-40°C to +85°C		±4					
			-55°C to +125°C		±4					
I_{IL}	Control input leakage current		V_{CC} or GND	0	6	25°C		±0.1	μA	
						-40°C to +85°C		±1		
						-55°C to +125°C		±1		
I_{CC}	Quiescent device current	$I_O = 0$	V_{CC} or GND	0	6	25°C		8	μA	
						-40°C to +85°C		80		
						-55°C to +125°C		160		
				-5	5	25°C		16		
						-40°C to +85°C		160		
						-55°C to +125°C		320		

6.6 Electrical Characteristics: HCT Devices

PARAMETER		TEST CONDITIONS					MIN	TYP	MAX	UNIT
		V _{IS} (V)	V _I (V)	V _{EE} (V)	V _{CC} (V)	T _A				
V _{IH}	High-level input voltage				4.5 to 5.5	25°C	2		V	
						-40°C to +85°C	2			
						-55°C to +125°C	2			
V _{IL}	Low-level input voltage				4.5 to 5.5	25°C		0.8	V	
						-40°C to +85°C		0.8		
						-55°C to +125°C		0.8		
r _{ON}	ON resistance I _O = 1 mA See Figure 6	V _{CC} or V _{EE}		0	4.5	25°C	70	160	Ω	
						-40°C to +85°C		200		
						-55°C to +125°C		240		
						25°C	40	120		
						-40°C to +85°C		150		
						-55°C to +125°C		180		
		V _{CC} to V _{EE}		0	4.5	25°C	90	180		
						-40°C to +85°C		225		
						-55°C to +125°C		270		
						25°C	45	130		
						-40°C to +85°C		162		
						-55°C to +125°C		195		
Δr _{ON}	Maximum ON resistance between any two channels			0	4.5	25°C	10	Ω		
				-4.5	4.5	25°C	5			

Electrical Characteristics: HCT Devices (continued)

PARAMETER		TEST CONDITIONS					MIN	TYP	MAX	UNIT
		V _{IS} (V)	V _I (V)	V _{EE} (V)	V _{CC} (V)	T _A				
I _{IZ}	1 and 2 channels	For switch OFF: When V _{IS} = V _{CC} , V _{OS} = V _{EE} ; When V _{IS} = V _{EE} , V _{OS} = V _{CC} For switch ON: All applicable combinations of V _{IS} and V _{OS} voltage levels	V _{IL} or V _{IH}	0	6	25°C		±0.1	μA	
						-40°C to +85°C		±1		
						-55°C to +125°C		±1		
	4053			-5	5	25°C		±0.1		
						-40°C to +85°C		±1		
						-55°C to +125°C		±1		
	4 channels			0	6	25°C		±0.1		
						-40°C to +85°C		±1		
						-55°C to +125°C		±1		
	4052			-5	5	25°C		±0.2		
						-40°C to +85°C		±2		
						-55°C to +125°C		±2		
	8 channels			0	6	25°C		±0.2		
						-40°C to +85°C		±2		
-55°C to +125°C			±2							
4051	-5	5	25°C		±0.4					
			-40°C to +85°C		±4					
			-55°C to +125°C		±4					
I _{IL}	Control input leakage current	See ⁽¹⁾		5.5	25°C		±0.1	μA		
					-40°C to +85°C		±1			
					-55°C to +125°C		±1			
I _{CC}	Quiescent device current	I _O = 0	V _{CC} or GND	0	5.5	25°C		8	μA	
						-40°C to +85°C		80		
						-55°C to +125°C		160		
				-4.5	5.5	25°C		16	μA	
						-40°C to +85°C		160		
						-55°C to +125°C		320		
ΔI _{CC}	Additional quiescent device current per input pin: 1 unit load ⁽²⁾	ΔI _{CC} ⁽²⁾	V _{CC} - 2.1	4.5 to 5.5	25°C	100	360	μA		
					-40°C to +85°C		450			
					-55°C to +125°C		490			

(1) Any voltage between V_{CC} and GND.

(2) For dual-supply systems, theoretical worst-case (V_I = 2.4 V, V_{CC} = 5.5 V) specification is 1.8 mA.

6.7 Switching Characteristics, $V_{CC} = 5\text{ V}$

$V_{CC} = 5\text{ V}$, $T_A = 25^\circ\text{C}$, input t_r , $t_f = 6\text{ ns}$

PARAMETER		TEST CONDITIONS		C_L (pF)	MIN	TYP	MAX	UNIT
t_{PHL} , t_{PLH}		Switch IN to OUT	CDx4HC4051	15		4		ns
			CDx4HCT4051			4		
			CDx4HC4052			4		
			CDx4HCT4052			4		
			CDx4HC4053			4		
			CDx4HCT4053			4		
t_{PHZ} , t_{PLZ}	Propagation delay	Switch turn-off (S or \bar{E})	CDx4HC4051	15		19		ns
			CDx4HCT4051			19		
			CDx4HC4052			21		
			CDx4HCT4052			21		
			CDx4HC4053			18		
			CDx4HCT4053			18		
t_{PZH} , t_{PZL}		Switch turn-on (S or \bar{E})	CDx4HC4051	15		19		ns
			CDx4HCT4051			23		
			CDx4HC4052			27		
			CDx4HCT4052			29		
			CDx4HC4053			18		
			CDx4HCT4053			20		
C_{PD}	Power dissipation capacitance ⁽¹⁾		CDx4HC4051			50		pF
			CDx4HCT4051			52		
			CDx4HC4052			74		
			CDx4HCT4052			76		
			CDx4HC4053			38		
			CDx4HCT4053			42		

(1) C_{PD} is used to determine the dynamic power consumption, per package. $P_D = C_{PD} V_{CC}^2 f_i + \sum (C_L + C_S) V_{CC}^2 f_o$, f_o = output frequency, f_i = input frequency, C_L = output load capacitance, C_S = switch capacitance, V_{CC} = supply voltage

6.8 Switching Characteristics, $C_L = 50$ pF

 $C_L = 50$ pF, input $t_r, t_f = 6$ ns

PARAMETER		V_{EE} (V)	V_{CC} (V)	TEST CONDITIONS		MIN	MAX	UNIT
t_{PLH}, t_{PHL}	Propagation delay, switch in to out	0	2	$T_A = 25^\circ\text{C}$	HC		60	ns
				$T_A = -40^\circ\text{C to } +85^\circ\text{C}$	HC		75	
				$T_A = -55^\circ\text{C to } +125^\circ\text{C}$	HC		90	
		0	4.5	$T_A = 25^\circ\text{C}$	HC, HCT		12	
				$T_A = -40^\circ\text{C to } +85^\circ\text{C}$	HC, HCT		15	
				$T_A = -55^\circ\text{C to } +125^\circ\text{C}$	HC, HCT		18	
		0	6	$T_A = 25^\circ\text{C}$	HC		10	
				$T_A = -40^\circ\text{C to } +85^\circ\text{C}$	HC		13	
				$T_A = -55^\circ\text{C to } +125^\circ\text{C}$	HC		15	
		-4.5	4.5	$T_A = 25^\circ\text{C}$	HC, HCT		8	
				$T_A = -40^\circ\text{C to } +85^\circ\text{C}$	HC, HCT		10	
				$T_A = -55^\circ\text{C to } +125^\circ\text{C}$	HC, HCT		12	
t_{PHZ}, t_{PLZ}	Maximum switch turn OFF delay from S or \bar{E} to switch output	0	2	$T_A = 25^\circ\text{C}$	HC		225	ns
				$T_A = -40^\circ\text{C to } +85^\circ\text{C}$	HC		280	
				$T_A = -55^\circ\text{C to } +125^\circ\text{C}$	HC		340	
		0	4.5	$T_A = 25^\circ\text{C}$	HC, HCT		45	
				$T_A = -40^\circ\text{C to } +85^\circ\text{C}$	HC, HCT		56	
				$T_A = -55^\circ\text{C to } +125^\circ\text{C}$	HC, HCT		68	
		0	6	$T_A = 25^\circ\text{C}$	HC		38	
				$T_A = -40^\circ\text{C to } +85^\circ\text{C}$	HC		48	
				$T_A = -55^\circ\text{C to } +125^\circ\text{C}$	HC		57	
		-4.5	4.5	$T_A = 25^\circ\text{C}$	HC, HCT		32	
				$T_A = -40^\circ\text{C to } +85^\circ\text{C}$	HC, HCT		40	
				$T_A = -55^\circ\text{C to } +125^\circ\text{C}$	HC, HCT		48	
t_{PHZ}, t_{PLZ}	Maximum switch turn OFF delay from S or \bar{E} to switch output	0	2	$T_A = 25^\circ\text{C}$	HC		250	ns
				$T_A = -40^\circ\text{C to } +85^\circ\text{C}$	HC		315	
				$T_A = -55^\circ\text{C to } +125^\circ\text{C}$	HC		375	
		0	4.5	$T_A = 25^\circ\text{C}$	HC, HCT		50	
				$T_A = -40^\circ\text{C to } +85^\circ\text{C}$	HC, HCT		63	
				$T_A = -55^\circ\text{C to } +125^\circ\text{C}$	HC, HCT		75	
		0	6	$T_A = 25^\circ\text{C}$	HC		43	
				$T_A = -40^\circ\text{C to } +85^\circ\text{C}$	HC		54	
				$T_A = -55^\circ\text{C to } +125^\circ\text{C}$	HC		65	
		-4.5	4.5	$T_A = 25^\circ\text{C}$	HC		38	
					HCT		38	
				$T_A = -40^\circ\text{C to } +85^\circ\text{C}$	HC		48	
					HCT		48	
				$T_A = -55^\circ\text{C to } +125^\circ\text{C}$	HC		57	
					HCT		57	

Switching Characteristics, $C_L = 50$ pF (continued)

$C_L = 50$ pF, input $t_r, t_f = 6$ ns

PARAMETER		V_{EE} (V)	V_{CC} (V)	TEST CONDITIONS		MIN	MAX	UNIT
t_{PHZ}, t_{PLZ}	Maximum switch turn OFF delay from S or \bar{E} to switch output	0	2	$T_A = 25^\circ\text{C}$	HC		210	ns
				$T_A = -40^\circ\text{C to } +85^\circ\text{C}$	HC		265	
				$T_A = -55^\circ\text{C to } +125^\circ\text{C}$	HC		315	
		0	4.5	$T_A = 25^\circ\text{C}$	HC		42	
					HCT		44	
				$T_A = -40^\circ\text{C to } +85^\circ\text{C}$	HC		53	
					HCT		53	
				$T_A = -55^\circ\text{C to } +125^\circ\text{C}$	HC		63	
					HCT		66	
		0	6	$T_A = 25^\circ\text{C}$	HC		36	
				$T_A = -40^\circ\text{C to } +85^\circ\text{C}$	HC		45	
				$T_A = -55^\circ\text{C to } +125^\circ\text{C}$	HC		54	
		-4.5	4.5	$T_A = 25^\circ\text{C}$	HC		29	
					HCT		31	
				$T_A = -40^\circ\text{C to } +85^\circ\text{C}$	HC		36	
HCT					39			
$T_A = -55^\circ\text{C to } +125^\circ\text{C}$	HC				44			
	HCT				47			
t_{PZL}, t_{PZH}	Maximum switch turn ON delay from S or \bar{E} to switch output	0	2	$T_A = 25^\circ\text{C}$	HC		225	ns
				$T_A = -40^\circ\text{C to } +85^\circ\text{C}$	HC		280	
				$T_A = -55^\circ\text{C to } +125^\circ\text{C}$	HC		340	
		0	4.5	$T_A = 25^\circ\text{C}$	HC		45	
					HCT		55	
				$T_A = -40^\circ\text{C to } +85^\circ\text{C}$	HC		56	
					HCT		69	
				$T_A = -55^\circ\text{C to } +125^\circ\text{C}$	HC		68	
					HCT		83	
		0	6	$T_A = 25^\circ\text{C}$	HC		38	
				$T_A = -40^\circ\text{C to } +85^\circ\text{C}$	HC		48	
				$T_A = -55^\circ\text{C to } +125^\circ\text{C}$	HC		57	
		-4.5	4.5	$T_A = 25^\circ\text{C}$	HC		32	
					HCT		39	
				$T_A = -40^\circ\text{C to } +85^\circ\text{C}$	HC		40	
HCT					49			
$T_A = -55^\circ\text{C to } +125^\circ\text{C}$	HC				48			
	HCT				59			

Switching Characteristics, $C_L = 50$ pF (continued)
 $C_L = 50$ pF, input $t_r, t_f = 6$ ns

PARAMETER		V_{EE} (V)	V_{CC} (V)	TEST CONDITIONS		MIN	MAX	UNIT
t_{PZL} , t_{PZH}	Maximum switch turn ON delay from S or \bar{E} to switch output	0	2	$T_A = 25^\circ\text{C}$	HC		325	ns
				$T_A = -40^\circ\text{C to } +85^\circ\text{C}$	HC		405	
				$T_A = -55^\circ\text{C to } +125^\circ\text{C}$	HC		490	
		0	4.5	$T_A = 25^\circ\text{C}$	HC		65	
					HCT		70	
				$T_A = -40^\circ\text{C to } +85^\circ\text{C}$	HC		81	
					HCT		68	
				$T_A = -55^\circ\text{C to } +125^\circ\text{C}$	HC		98	
					HCT		105	
		0	6	$T_A = 25^\circ\text{C}$	HC		55	
				$T_A = -40^\circ\text{C to } +85^\circ\text{C}$	HC		69	
				$T_A = -55^\circ\text{C to } +125^\circ\text{C}$	HC		83	
		-4.5	4.5	$T_A = 25^\circ\text{C}$	HC		46	
					HCT		48	
				$T_A = -40^\circ\text{C to } +85^\circ\text{C}$	HC		58	
HCT					60			
$T_A = -55^\circ\text{C to } +125^\circ\text{C}$	HC				69			
	HCT				72			
t_{PZL} , t_{PZH}	Maximum switch turn ON delay from S or \bar{E} to switch output	0	2	$T_A = 25^\circ\text{C}$	HC		220	ns
				$T_A = -40^\circ\text{C to } +85^\circ\text{C}$	HC		275	
				$T_A = -55^\circ\text{C to } +125^\circ\text{C}$	HC		330	
		0	4.5	$T_A = 25^\circ\text{C}$	HC		44	
					HCT		48	
				$T_A = -40^\circ\text{C to } +85^\circ\text{C}$	HC		55	
					HCT		60	
				$T_A = -55^\circ\text{C to } +125^\circ\text{C}$	HC		66	
					HCT		72	
		0	6	$T_A = 25^\circ\text{C}$	HC		37	
				$T_A = -40^\circ\text{C to } +85^\circ\text{C}$	HC		47	
				$T_A = -55^\circ\text{C to } +125^\circ\text{C}$	HC		56	
		-4.5	4.5	$T_A = 25^\circ\text{C}$	HC		31	
					HCT		34	
				$T_A = -40^\circ\text{C to } +85^\circ\text{C}$	HC		39	
HCT					43			
$T_A = -55^\circ\text{C to } +125^\circ\text{C}$	HC				47			
	HCT				51			
C_I	Input (control) capacitance			$T_A = 25^\circ\text{C}$	HC, HCT		10	pF
				$T_A = -40^\circ\text{C to } +85^\circ\text{C}$	HC, HCT		10	
				$T_A = -55^\circ\text{C to } +125^\circ\text{C}$	HC, HCT		10	

6.9 Analog Channel Specifications

Typical values at $T_A = 25^\circ\text{C}$

PARAMETER	TEST CONDITIONS	HC, HCT TYPES	V_{EE} (V)	V_{CC} (V)	TYP	UNIT
C_I	Switch input capacitance	All			5	pF
C_{COM}	Common output capacitance	4051			25	pF
		4052			12	
		4053			8	
f_{MAX}	Minimum switch frequency response at -3 dB (see Figure 3, Figure 5, and Figure 7)	4051	-2.25	2.25	145	MHz
		4052			165	
		4053			200	
		4051	-4.5	4.5	180	
		4052			185	
		4053			200	
Sine-wave distortion	See Figure 12	All	-2.25%	2.25%	0.035%	
		All	-4.5%	4.5%	0.018%	
Switch OFF signal feedthrough (see Figure 4, Figure 6, and Figure 8)	See Figure 14 ⁽²⁾⁽³⁾	4051	-2.25	2.25	-73	dB
		4052			-65	
		4053			-64	
		4051	-4.5	4.5	-75	
		4052			-67	
		4053			-66	

- (1) Adjust input voltage to obtain 0 dBm at V_{OS} for $f_{IN} = 1$ MHz.
- (2) V_{IS} is centered at $(V_{CC} - V_{EE}) / 2$.
- (3) Adjust input for 0 dBm.

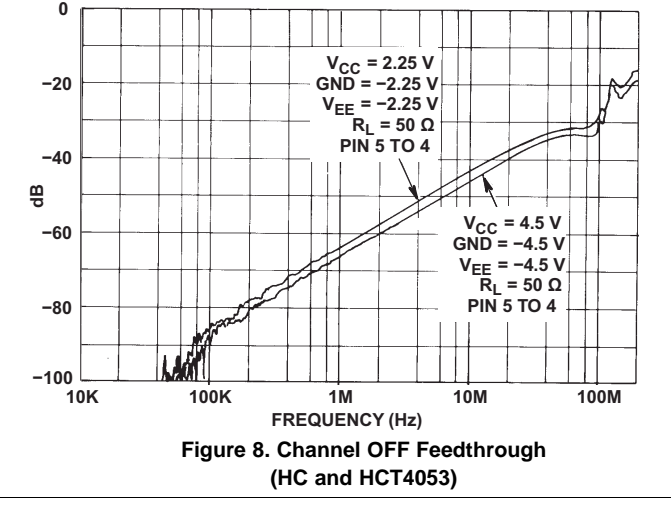
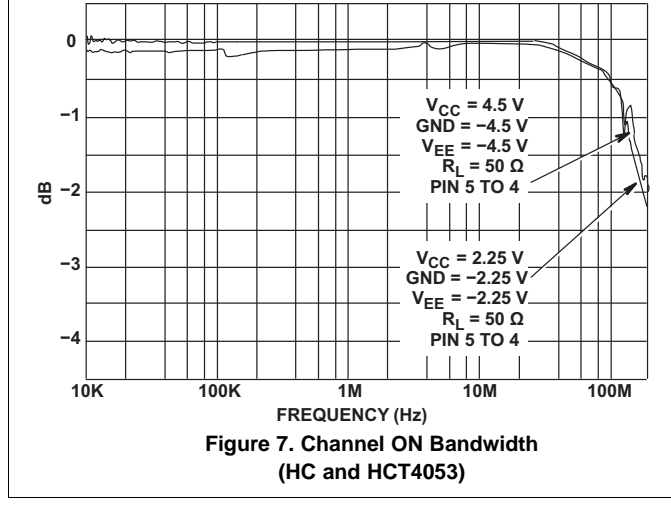
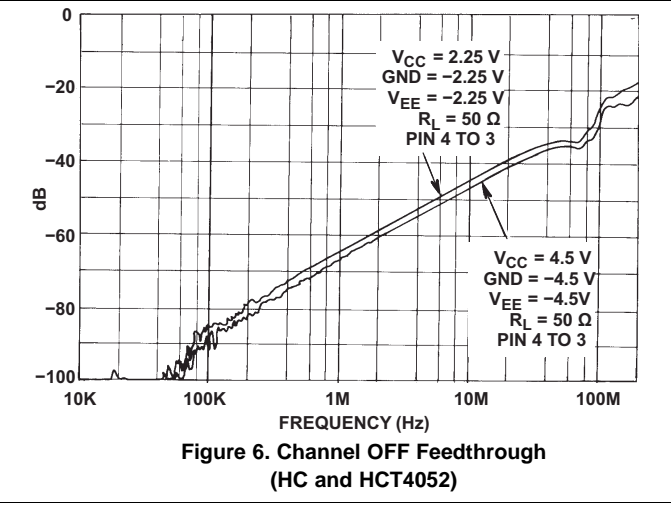
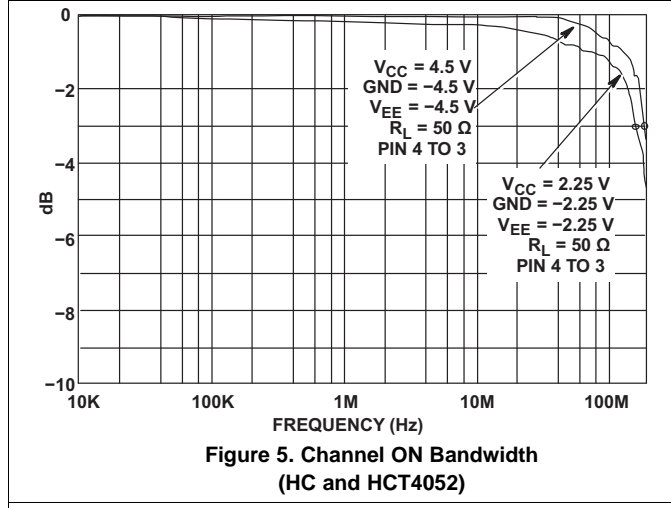
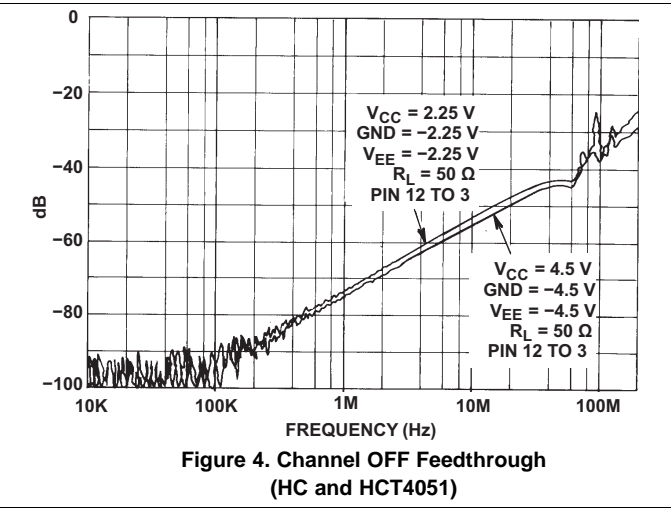
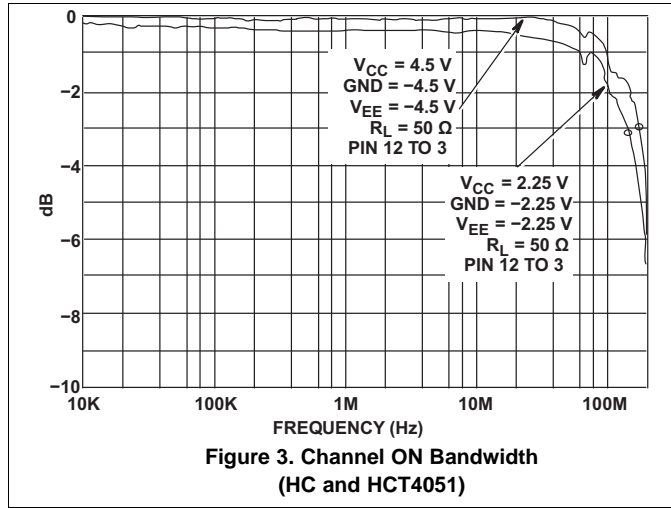

Figure 1. Recommended Operating Area as a Function of $(V_{CC} - V_{EE})$

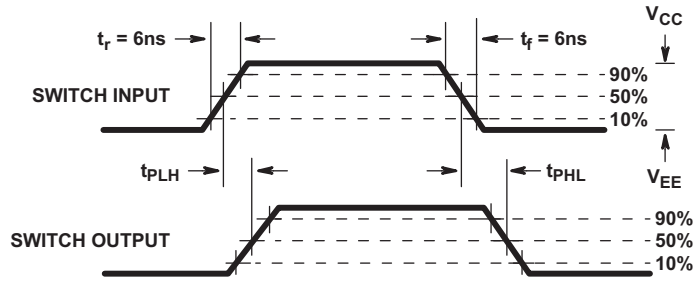

Figure 2. Recommended Operating Area as a Function of $(V_{EE} - \text{GND})$

6.10 Typical Characteristics



7 Parameter Measurement Information



(FIGURE A)



(FIGURE B) HC TYPES



(FIGURE C) HCT TYPES

Figure 9. Switch Propagation Delay, Turn-On, Turn-Off Times



Figure 10. Frequency Response Test Circuit



Figure 11. Crosstalk Between Two Switches Test Circuit



Figure 12. 1/4 Sine-Wave Distortion Test Circuit

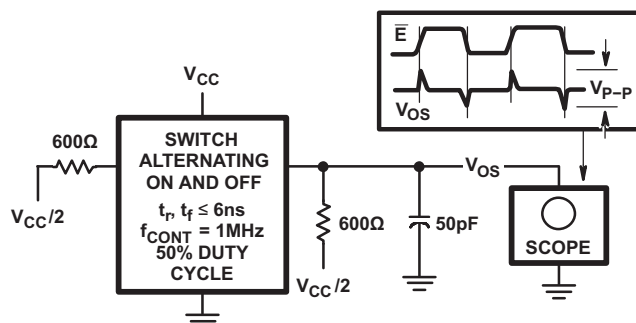

Figure 13. Control to Switch Feedthrough Noise Test Circuit



Figure 14. Switch OFF Signal Feedthrough



Figure 15. Switch ON/OFF Propagation Delay Test Circuit

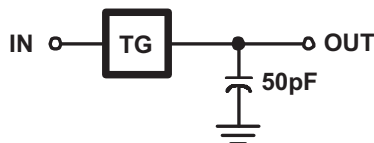

Figure 16. Switch In to Switch Out Propagation Delay Test Circuit

8 Detailed Description

8.1 Overview

The CDx4HCx4051 devices are a single 8-channel multiplexer having three binary control inputs, S_0 , S_1 , and S_2 and an $\overline{\text{ENABLE}}$ input. The three binary signals select 1 of 8 channels to be turned on, and connect one of the 8 inputs to the output.

The CDx4HCx4052 devices are a differential 4-channel multiplexer having two binary control inputs, S_0 and S_1 , and an $\overline{\text{ENABLE}}$ input. The two binary input signals select 1 of 4 pairs of channels to be turned on and connect the analog inputs to the outputs.

The CDx4HCx4053 devices are a triple 2-channel multiplexer having three separate digital control inputs, S_0 , S_1 , and S_2 and an $\overline{\text{ENABLE}}$ input. Each control input selects one of a pair of channels that are connected in a single-pole, double-throw configuration.

When these devices are used as demultiplexers, the CHANNEL IN/OUT terminals are the outputs and the COMMON OUT/IN terminals are the inputs.

8.2 Functional Block Diagrams



All inputs are protected by standard CMOS protection network.

Figure 17. CDx4HCx4051 Functional Block Diagram

Functional Block Diagrams (continued)



All inputs are protected by standard CMOS protection network.

Figure 18. CDx4HCx4052 Functional Block Diagram

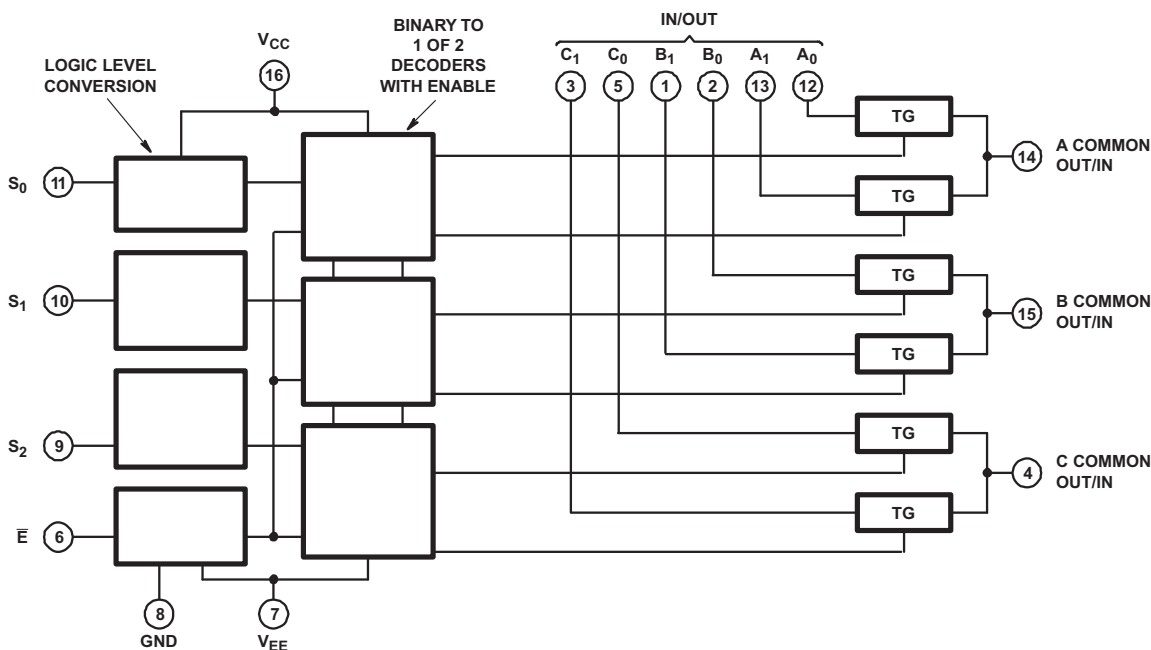

All inputs are protected by standard CMOS protection network.

Figure 19. CDx4HCx4053 Functional Block Diagram

8.3 Feature Description

The CDx4HCx405x line of multiplexers and demultiplexers can accept a wide range of analog signal levels from –5 to +5 V. They have low ON resistance, typically 70-Ω for $V_{CC} - V_{EE} = 4.5$ V and 40-Ω for $V_C - V_{EE} = 4.5$ V, which allows for very little signal loss through the switch.

Binary address decoding on chip makes channel selection easy. When channels are changed, a break-before-make system eliminates channel overlap.

8.4 Device Functional Modes

Table 1. CD54HC4051, CD74HC4051, CD54HCT4051, CD74HCT4051 Function Table⁽¹⁾

INPUT STATES				ON CHANNEL
ENABLE	S ₂	S ₁	S ₀	
L	L	L	L	A0
L	L	L	H	A1
L	L	H	L	A2
L	L	H	H	A3
L	H	L	L	A4
L	H	L	H	A5
L	H	H	L	A6
L	H	H	H	A7
H	X	X	X	None

(1) X = Don't care

Table 2. CD54HC4052, CD74HC4052, CD54HCT4052, CD74HCT4052 Function Table⁽¹⁾

INPUT STATES			ON CHANNELS
ENABLE	S ₁	S ₀	
L	L	L	A0, B0
L	L	H	A1, B1
L	H	L	A2, B2
L	H	H	A3, B3
H	X	X	None

(1) X = Don't care

Table 3. CD54HC4053, CD74HC4053, CD54HCT4053, CD74HCT4053 Function Table⁽¹⁾

INPUT STATES				ON CHANNELS
ENABLE	S ₂	S ₁	S ₀	
L	L	L	L	C0, B0, A0
L	L	L	H	C0, B0, A1
L	L	H	L	C0, B1, A0
L	L	H	H	C0, B1, A1
L	H	L	L	C1, B0, A0
L	H	L	H	C1, B0, A1
L	H	H	L	C1, B1, A0
L	H	H	H	C1, B1, A1
H	X	X	X	None

(1) X = Don't care

9 Application and Implementation

NOTE

Information in the following applications sections is not part of the TI component specification, and TI does not warrant its accuracy or completeness. TI's customers are responsible for determining suitability of components for their purposes. Customers should validate and test their design implementation to confirm system functionality.

9.1 Application Information

The CDx4HCx405x line of multiplexers and demultiplexers can be used for a wide variety of applications.

9.2 Typical Application

One application of the CD74HC4051 device is used in conjunction with a microcontroller to poll a keypad. Figure 20 shows the basic schematic for such a polling system. The microcontroller uses the channel-select pins to cycle through the different channels while reading the input to see if a user is pressing any of the keys. This is a very robust setup that allows for simultaneous key presses with very little power consumption. It also uses very few pins on the microcontroller. The down side of polling is that the microcontroller must frequently scan the keys for a press.

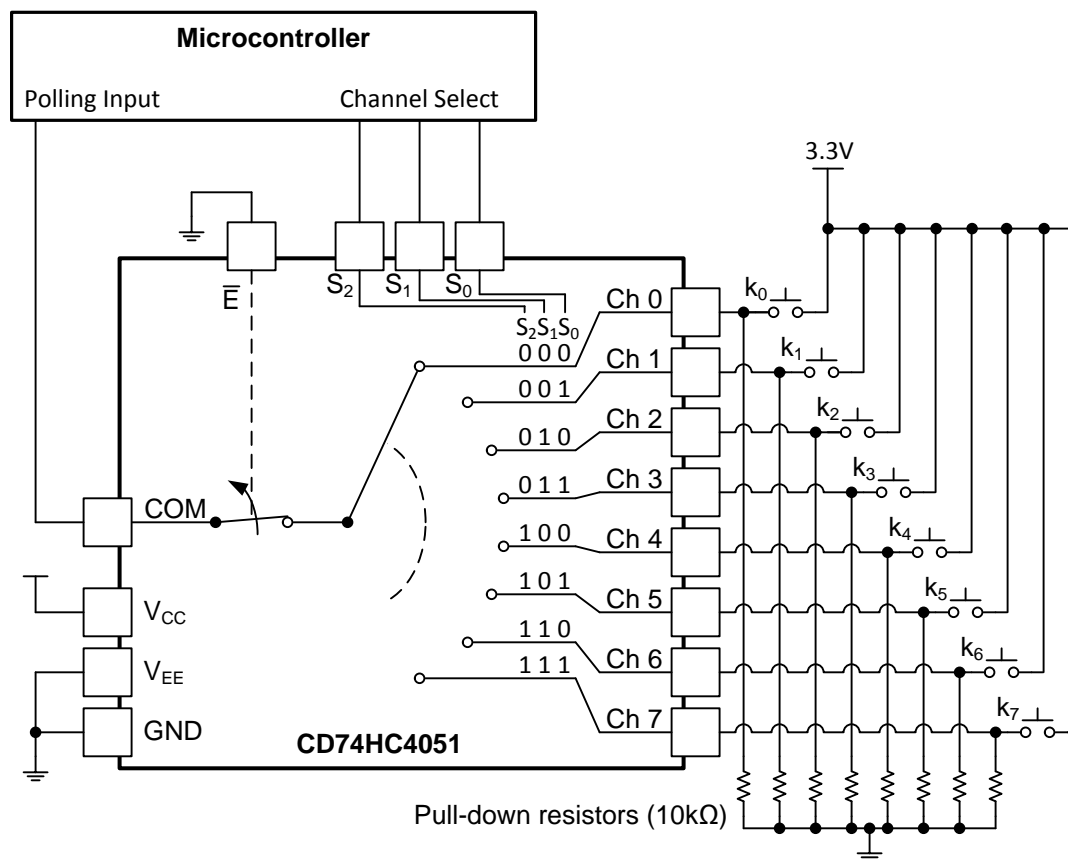

Figure 20. CD74HC4051 Being Used to Help Read Button Presses on a Keypad

9.2.1 Design Requirements

These devices use CMOS technology and have balanced output drive. Take care to avoid bus contention because it can drive currents that would exceed maximum limits. The high drive will also create fast edges into light loads, so routing and load conditions must be considered to prevent ringing.

Typical Application (continued)

See [Table 4](#) for the input loading details.

Table 4. HCT Input Loading Table

TYPE	INPUT	UNIT LOADS ⁽¹⁾
4051, 4053	All	0.5
4052	All	0.4

(1) Unit load is ΔI_{CC} limit specified in [Specifications](#), for example, 360-mA MAX at 25°C.

9.2.2 Detailed Design Procedure

- Recommended input conditions:
 - For switch time specifications, see propagation delay times in [Electrical Characteristics: HC Devices](#).
 - Inputs must not be pushed more than 0.5 V above V_{DD} or below V_{EE} .
 - For input voltage level specifications for control inputs, see V_{IH} and V_{IL} in [Electrical Characteristics: HC Devices](#).
- Recommended output conditions:
 - Outputs must not be pulled above V_{DD} or below V_{EE} .
- Input and output current consideration:
 - The CDx4HCx405x series of parts do not have internal current-drive circuitry, and thus cannot sink or source current. Any current will be passed through the device.

9.2.3 Application Curve



Figure 21. Typical ON Resistance vs Input Signal Voltage

10 Power Supply Recommendations

The power supply can be any voltage between the minimum and maximum supply voltage rating located in the [Electrical Characteristics: HC Devices](#).

Each V_{CC} terminal must have a good bypass capacitor to prevent power disturbance. For devices with a single supply, a 0.1- μF bypass capacitor is recommended. If there are multiple pins labeled V_{CC} , then a 0.01- μF or 0.022- μF capacitor is recommended for each V_{CC} because the V_{CC} pins will be tied together internally. For devices with dual-supply pins operating at different voltages, for example V_{CC} and V_{DD} , a 0.1- μF bypass capacitor is recommended for each supply pin. It is acceptable to parallel multiple bypass capacitors to reject different frequencies of noise. A 0.1- μF and a 1- μF capacitor are commonly used in parallel. For best results, the bypass capacitor or capacitors must be installed as close as possible to the power terminal.

11 Layout

11.1 Layout Guidelines

Reflections and matching are closely related to loop antenna theory, but different enough to warrant their own discussion. When a PCB trace turns a corner at a 90° angle, a reflection can occur. This is primarily due to the change in width of the trace. At the apex of the turn, the trace width is increased to 1.414 times its width. This change in width upsets the transmission line characteristics, especially the distributed capacitance and self-inductance of the trace, thus resulting in the reflection. Not all PCB traces can be straight, so they will have to turn corners. Figure 22 shows progressively better techniques of rounding corners. Only the last example (BEST) maintains constant trace width and minimizes reflections.

11.2 Layout Example

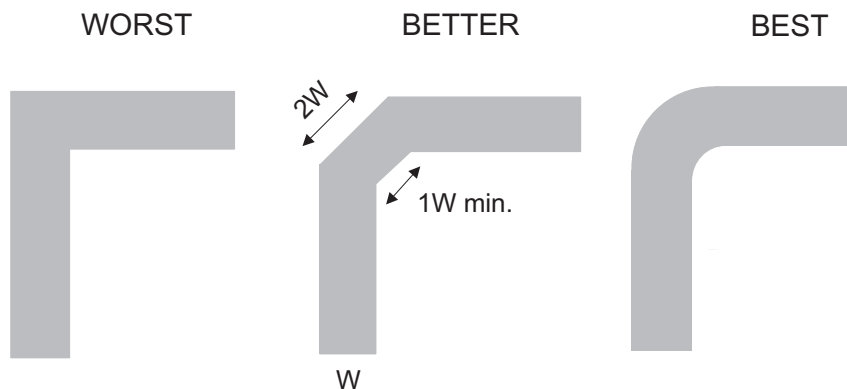

Figure 22. Trace Example

12 Device and Documentation Support

12.1 Documentation Support

12.1.1 Related Documentation

For related documentation see the following:

[Implications of Slow or Floating CMOS Inputs, SCBA004](#)

12.2 Related Links

The table below lists quick access links. Categories include technical documents, support and community resources, tools and software, and quick access to sample or buy.

Table 5. Related Links

PARTS	PRODUCT FOLDER	SAMPLE & BUY	TECHNICAL DOCUMENTS	TOOLS & SOFTWARE	SUPPORT & COMMUNITY
CD54HC4051	Click here	Click here	Click here	Click here	Click here
CD74HC4051	Click here	Click here	Click here	Click here	Click here
CD54HCT4051	Click here	Click here	Click here	Click here	Click here
CD74HCT4051	Click here	Click here	Click here	Click here	Click here
CD54HC4052	Click here	Click here	Click here	Click here	Click here
CD74HC4052	Click here	Click here	Click here	Click here	Click here
CD54HCT4052	Click here	Click here	Click here	Click here	Click here
CD74HCT4052	Click here	Click here	Click here	Click here	Click here
CD54HC4053	Click here	Click here	Click here	Click here	Click here
CD74HC4053	Click here	Click here	Click here	Click here	Click here
CD54HCT4053	Click here	Click here	Click here	Click here	Click here
CD74HCT4053	Click here	Click here	Click here	Click here	Click here

12.3 Receiving Notification of Documentation Updates

To receive notification of documentation updates, navigate to the device product folder on ti.com. In the upper right corner, click on *Alert me* to register and receive a weekly digest of any product information that has changed. For change details, review the revision history included in any revised document.

12.4 Community Resources

The following links connect to TI community resources. Linked contents are provided "AS IS" by the respective contributors. They do not constitute TI specifications and do not necessarily reflect TI's views; see TI's [Terms of Use](#).

TI E2E™ Online Community *TI's Engineer-to-Engineer (E2E) Community*. Created to foster collaboration among engineers. At e2e.ti.com, you can ask questions, share knowledge, explore ideas and help solve problems with fellow engineers.

Design Support *TI's Design Support* Quickly find helpful E2E forums along with design support tools and contact information for technical support.

12.5 Trademarks

E2E is a trademark of Texas Instruments.
 All other trademarks are the property of their respective owners.

12.6 Electrostatic Discharge Caution



These devices have limited built-in ESD protection. The leads should be shorted together or the device placed in conductive foam during storage or handling to prevent electrostatic damage to the MOS gates.

12.7 Glossary

[SLYZ022](#) — *TI Glossary*.

This glossary lists and explains terms, acronyms, and definitions.

13 Mechanical, Packaging, and Orderable Information

The following pages include mechanical, packaging, and orderable information. This information is the most current data available for the designated devices. This data is subject to change without notice and revision of this document. For browser-based versions of this data sheet, refer to the left-hand navigation.

PACKAGING INFORMATION

Orderable Device	Status (1)	Package Type	Package Drawing	Pins	Package Qty	Eco Plan (2)	Lead/Ball Finish (6)	MSL Peak Temp (3)	Op Temp (°C)	Device Marking (4/5)	Samples
5962-8775401EA	ACTIVE	CDIP	J	16	1	TBD	A42	N / A for Pkg Type	-55 to 125	5962-8775401EA CD54HC4053F3A	Samples
5962-8855601EA	ACTIVE	CDIP	J	16	1	TBD	A42	N / A for Pkg Type	-55 to 125	5962-8855601EA CD54HC4052F3A	Samples
5962-9065401MEA	ACTIVE	CDIP	J	16	1	TBD	A42	N / A for Pkg Type	-55 to 125	5962-9065401ME A CD54HCT4051F3A	Samples
CD54HC4051F	ACTIVE	CDIP	J	16	1	TBD	A42	N / A for Pkg Type	-55 to 125	CD54HC4051F	Samples
CD54HC4051F3A	ACTIVE	CDIP	J	16	1	TBD	A42	N / A for Pkg Type	-55 to 125	CD54HC4051F3A	Samples
CD54HC4052F	ACTIVE	CDIP	J	16	1	TBD	A42	N / A for Pkg Type	-55 to 125	CD54HC4052F	Samples
CD54HC4052F3A	ACTIVE	CDIP	J	16	1	TBD	A42	N / A for Pkg Type	-55 to 125	5962-8855601EA CD54HC4052F3A	Samples
CD54HC4053F	ACTIVE	CDIP	J	16	1	TBD	A42	N / A for Pkg Type	-55 to 125	CD54HC4053F	Samples
CD54HC4053F3A	ACTIVE	CDIP	J	16	1	TBD	A42	N / A for Pkg Type	-55 to 125	5962-8775401EA CD54HC4053F3A	Samples
CD54HCT4051F3A	ACTIVE	CDIP	J	16	1	TBD	A42	N / A for Pkg Type	-55 to 125	5962-9065401ME A CD54HCT4051F3A	Samples
CD74HC4051E	ACTIVE	PDIP	N	16	25	Green (RoHS & no Sb/Br)	CU NIPDAU	N / A for Pkg Type	-55 to 125	CD74HC4051E	Samples
CD74HC4051EE4	ACTIVE	PDIP	N	16	25	Green (RoHS & no Sb/Br)	CU NIPDAU	N / A for Pkg Type	-55 to 125	CD74HC4051E	Samples
CD74HC4051M	ACTIVE	SOIC	D	16	40	Green (RoHS & no Sb/Br)	CU NIPDAU	Level-1-260C-UNLIM	-55 to 125	HC4051M	Samples
CD74HC4051M96	ACTIVE	SOIC	D	16	2500	Green (RoHS & no Sb/Br)	CU NIPDAU CU SN	Level-1-260C-UNLIM	-55 to 125	HC4051M	Samples
CD74HC4051M96E4	ACTIVE	SOIC	D	16	2500	Green (RoHS & no Sb/Br)	CU NIPDAU	Level-1-260C-UNLIM	-55 to 125	HC4051M	Samples
CD74HC4051M96G3	ACTIVE	SOIC	D	16	2500	Green (RoHS & no Sb/Br)	CU SN	Level-1-260C-UNLIM	-55 to 125	HC4051M	Samples
CD74HC4051M96G4	ACTIVE	SOIC	D	16	2500	Green (RoHS & no Sb/Br)	CU NIPDAU	Level-1-260C-UNLIM	-55 to 125	HC4051M	Samples

Orderable Device	Status (1)	Package Type	Package Drawing	Pins	Package Qty	Eco Plan (2)	Lead/Ball Finish (6)	MSL Peak Temp (3)	Op Temp (°C)	Device Marking (4/5)	Samples
CD74HC4051ME4	ACTIVE	SOIC	D	16	40	Green (RoHS & no Sb/Br)	CU NIPDAU	Level-1-260C-UNLIM	-55 to 125	HC4051M	Samples
CD74HC4051MT	ACTIVE	SOIC	D	16	250	Green (RoHS & no Sb/Br)	CU NIPDAU	Level-1-260C-UNLIM	-55 to 125	HC4051M	Samples
CD74HC4051NSR	ACTIVE	SO	NS	16	2000	Green (RoHS & no Sb/Br)	CU NIPDAU	Level-1-260C-UNLIM	-55 to 125	HC4051M	Samples
CD74HC4051NSRE4	ACTIVE	SO	NS	16	2000	Green (RoHS & no Sb/Br)	CU NIPDAU	Level-1-260C-UNLIM	-55 to 125	HC4051M	Samples
CD74HC4051PWR	ACTIVE	TSSOP	PW	16	2000	Green (RoHS & no Sb/Br)	CU NIPDAU CU SN	Level-1-260C-UNLIM	-55 to 125	HJ4051	Samples
CD74HC4051PWRG4	ACTIVE	TSSOP	PW	16	2000	Green (RoHS & no Sb/Br)	CU NIPDAU	Level-1-260C-UNLIM	-55 to 125	HJ4051	Samples
CD74HC4051PWT	ACTIVE	TSSOP	PW	16	250	Green (RoHS & no Sb/Br)	CU NIPDAU	Level-1-260C-UNLIM	-55 to 125	HJ4051	Samples
CD74HC4051PWTG4	ACTIVE	TSSOP	PW	16	250	Green (RoHS & no Sb/Br)	CU NIPDAU	Level-1-260C-UNLIM	-55 to 125	HJ4051	Samples
CD74HC4052E	ACTIVE	PDIP	N	16	25	Green (RoHS & no Sb/Br)	CU NIPDAU	N / A for Pkg Type	-55 to 125	CD74HC4052E	Samples
CD74HC4052M	ACTIVE	SOIC	D	16	40	Green (RoHS & no Sb/Br)	CU NIPDAU	Level-1-260C-UNLIM	-55 to 125	HC4052M	Samples
CD74HC4052M96	ACTIVE	SOIC	D	16	2500	Green (RoHS & no Sb/Br)	CU NIPDAU CU SN	Level-1-260C-UNLIM	-55 to 125	HC4052M	Samples
CD74HC4052M96E4	ACTIVE	SOIC	D	16	2500	Green (RoHS & no Sb/Br)	CU NIPDAU	Level-1-260C-UNLIM	-55 to 125	HC4052M	Samples
CD74HC4052M96G4	ACTIVE	SOIC	D	16	2500	Green (RoHS & no Sb/Br)	CU NIPDAU	Level-1-260C-UNLIM	-55 to 125	HC4052M	Samples
CD74HC4052MT	ACTIVE	SOIC	D	16	250	Green (RoHS & no Sb/Br)	CU NIPDAU	Level-1-260C-UNLIM	-55 to 125	HC4052M	Samples
CD74HC4052NSR	ACTIVE	SO	NS	16	2000	Green (RoHS & no Sb/Br)	CU NIPDAU	Level-1-260C-UNLIM	-55 to 125	HC4052M	Samples
CD74HC4052NSRG4	ACTIVE	SO	NS	16	2000	Green (RoHS & no Sb/Br)	CU NIPDAU	Level-1-260C-UNLIM	-55 to 125	HC4052M	Samples
CD74HC4052PW	ACTIVE	TSSOP	PW	16	90	Green (RoHS & no Sb/Br)	CU NIPDAU	Level-1-260C-UNLIM	-55 to 125	HJ4052	Samples
CD74HC4052PWR	ACTIVE	TSSOP	PW	16	2000	Green (RoHS & no Sb/Br)	CU NIPDAU CU SN	Level-1-260C-UNLIM	-55 to 125	HJ4052	Samples

Orderable Device	Status (1)	Package Type	Package Drawing	Pins	Package Qty	Eco Plan (2)	Lead/Ball Finish (6)	MSL Peak Temp (3)	Op Temp (°C)	Device Marking (4/5)	Samples
CD74HC4052PWRG4	ACTIVE	TSSOP	PW	16	2000	Green (RoHS & no Sb/Br)	CU NIPDAU	Level-1-260C-UNLIM	-55 to 125	HJ4052	Samples
CD74HC4052PWT	ACTIVE	TSSOP	PW	16	250	Green (RoHS & no Sb/Br)	CU NIPDAU	Level-1-260C-UNLIM	-55 to 125	HJ4052	Samples
CD74HC4053E	ACTIVE	PDIP	N	16	25	Green (RoHS & no Sb/Br)	CU NIPDAU	N / A for Pkg Type	-55 to 125	CD74HC4053E	Samples
CD74HC4053EE4	ACTIVE	PDIP	N	16	25	Green (RoHS & no Sb/Br)	CU NIPDAU	N / A for Pkg Type	-55 to 125	CD74HC4053E	Samples
CD74HC4053M	ACTIVE	SOIC	D	16	40	Green (RoHS & no Sb/Br)	CU NIPDAU	Level-1-260C-UNLIM	-55 to 125	HC4053M	Samples
CD74HC4053M96	ACTIVE	SOIC	D	16	2500	Green (RoHS & no Sb/Br)	CU NIPDAU CU SN	Level-1-260C-UNLIM	-55 to 125	HC4053M	Samples
CD74HC4053M96G3	ACTIVE	SOIC	D	16	2500	Green (RoHS & no Sb/Br)	CU SN	Level-1-260C-UNLIM	-55 to 125	HC4053M	Samples
CD74HC4053M96G4	ACTIVE	SOIC	D	16	2500	Green (RoHS & no Sb/Br)	CU NIPDAU	Level-1-260C-UNLIM	-55 to 125	HC4053M	Samples
CD74HC4053ME4	ACTIVE	SOIC	D	16	40	Green (RoHS & no Sb/Br)	CU NIPDAU	Level-1-260C-UNLIM	-55 to 125	HC4053M	Samples
CD74HC4053MG4	ACTIVE	SOIC	D	16	40	Green (RoHS & no Sb/Br)	CU NIPDAU	Level-1-260C-UNLIM	-55 to 125	HC4053M	Samples
CD74HC4053MT	ACTIVE	SOIC	D	16	250	Green (RoHS & no Sb/Br)	CU NIPDAU	Level-1-260C-UNLIM	-55 to 125	HC4053M	Samples
CD74HC4053NSR	ACTIVE	SO	NS	16	2000	Green (RoHS & no Sb/Br)	CU NIPDAU	Level-1-260C-UNLIM	-55 to 125	HC4053M	Samples
CD74HC4053PW	ACTIVE	TSSOP	PW	16	90	Green (RoHS & no Sb/Br)	CU NIPDAU	Level-1-260C-UNLIM	-55 to 125	HJ4053	Samples
CD74HC4053PWR	ACTIVE	TSSOP	PW	16	2000	Green (RoHS & no Sb/Br)	CU NIPDAU CU SN	Level-1-260C-UNLIM	-55 to 125	HJ4053	Samples
CD74HC4053PWRG4	ACTIVE	TSSOP	PW	16	2000	Green (RoHS & no Sb/Br)	CU NIPDAU	Level-1-260C-UNLIM	-55 to 125	HJ4053	Samples
CD74HC4053PWT	ACTIVE	TSSOP	PW	16	250	Green (RoHS & no Sb/Br)	CU NIPDAU	Level-1-260C-UNLIM	-55 to 125	HJ4053	Samples
CD74HCT4051E	ACTIVE	PDIP	N	16	25	Green (RoHS & no Sb/Br)	CU NIPDAU	N / A for Pkg Type	-55 to 125	CD74HCT4051E	Samples
CD74HCT4051M	ACTIVE	SOIC	D	16	40	Green (RoHS & no Sb/Br)	CU NIPDAU	Level-1-260C-UNLIM	-55 to 125	HCT4051M	Samples

Orderable Device	Status (1)	Package Type	Package Drawing	Pins	Package Qty	Eco Plan (2)	Lead/Ball Finish (6)	MSL Peak Temp (3)	Op Temp (°C)	Device Marking (4/5)	Samples
CD74HCT4051M96	ACTIVE	SOIC	D	16	2500	Green (RoHS & no Sb/Br)	CU NIPDAU	Level-1-260C-UNLIM	-55 to 125	HCT4051M	Samples
CD74HCT4051M96E4	ACTIVE	SOIC	D	16	2500	Green (RoHS & no Sb/Br)	CU NIPDAU	Level-1-260C-UNLIM	-55 to 125	HCT4051M	Samples
CD74HCT4051M96G4	ACTIVE	SOIC	D	16	2500	Green (RoHS & no Sb/Br)	CU NIPDAU	Level-1-260C-UNLIM	-55 to 125	HCT4051M	Samples
CD74HCT4051ME4	ACTIVE	SOIC	D	16	40	Green (RoHS & no Sb/Br)	CU NIPDAU	Level-1-260C-UNLIM	-55 to 125	HCT4051M	Samples
CD74HCT4051MG4	ACTIVE	SOIC	D	16	40	Green (RoHS & no Sb/Br)	CU NIPDAU	Level-1-260C-UNLIM	-55 to 125	HCT4051M	Samples
CD74HCT4051MT	ACTIVE	SOIC	D	16	250	Green (RoHS & no Sb/Br)	CU NIPDAU	Level-1-260C-UNLIM	-55 to 125	HCT4051M	Samples
CD74HCT4051MTG4	ACTIVE	SOIC	D	16	250	Green (RoHS & no Sb/Br)	CU NIPDAU	Level-1-260C-UNLIM	-55 to 125	HCT4051M	Samples
CD74HCT4052E	ACTIVE	PDIP	N	16	25	Green (RoHS & no Sb/Br)	CU NIPDAU	N / A for Pkg Type	-55 to 125	CD74HCT4052E	Samples
CD74HCT4052M	ACTIVE	SOIC	D	16	40	Green (RoHS & no Sb/Br)	CU NIPDAU	Level-1-260C-UNLIM	-55 to 125	HCT4052M	Samples
CD74HCT4052M96	ACTIVE	SOIC	D	16	2500	Green (RoHS & no Sb/Br)	CU NIPDAU	Level-1-260C-UNLIM	-55 to 125	HCT4052M	Samples
CD74HCT4052M96G4	ACTIVE	SOIC	D	16	2500	Green (RoHS & no Sb/Br)	CU NIPDAU	Level-1-260C-UNLIM	-55 to 125	HCT4052M	Samples
CD74HCT4052ME4	ACTIVE	SOIC	D	16	40	Green (RoHS & no Sb/Br)	CU NIPDAU	Level-1-260C-UNLIM	-55 to 125	HCT4052M	Samples
CD74HCT4052MG4	ACTIVE	SOIC	D	16	40	Green (RoHS & no Sb/Br)	CU NIPDAU	Level-1-260C-UNLIM	-55 to 125	HCT4052M	Samples
CD74HCT4052MT	ACTIVE	SOIC	D	16	250	Green (RoHS & no Sb/Br)	CU NIPDAU	Level-1-260C-UNLIM	-55 to 125	HCT4052M	Samples
CD74HCT4053E	ACTIVE	PDIP	N	16	25	Green (RoHS & no Sb/Br)	CU NIPDAU	N / A for Pkg Type	-55 to 125	CD74HCT4053E	Samples
CD74HCT4053M	ACTIVE	SOIC	D	16	40	Green (RoHS & no Sb/Br)	CU NIPDAU	Level-1-260C-UNLIM	-55 to 125	HCT4053M	Samples
CD74HCT4053M96	ACTIVE	SOIC	D	16	2500	Green (RoHS & no Sb/Br)	CU NIPDAU	Level-1-260C-UNLIM	-55 to 125	HCT4053M	Samples
CD74HCT4053M96E4	ACTIVE	SOIC	D	16	2500	Green (RoHS & no Sb/Br)	CU NIPDAU	Level-1-260C-UNLIM	-55 to 125	HCT4053M	Samples

Orderable Device	Status (1)	Package Type	Package Drawing	Pins	Package Qty	Eco Plan (2)	Lead/Ball Finish (6)	MSL Peak Temp (3)	Op Temp (°C)	Device Marking (4/5)	Samples
CD74HCT4053M96G4	ACTIVE	SOIC	D	16	2500	Green (RoHS & no Sb/Br)	CU NIPDAU	Level-1-260C-UNLIM	-55 to 125	HCT4053M	Samples
CD74HCT4053ME4	ACTIVE	SOIC	D	16	40	Green (RoHS & no Sb/Br)	CU NIPDAU	Level-1-260C-UNLIM	-55 to 125	HCT4053M	Samples
CD74HCT4053MT	ACTIVE	SOIC	D	16	250	Green (RoHS & no Sb/Br)	CU NIPDAU	Level-1-260C-UNLIM	-55 to 125	HCT4053M	Samples
CD74HCT4053PWR	ACTIVE	TSSOP	PW	16	2000	Green (RoHS & no Sb/Br)	CU NIPDAU CU SN	Level-1-260C-UNLIM	-55 to 125	HK4053	Samples
CD74HCT4053PWRE4	ACTIVE	TSSOP	PW	16	2000	Green (RoHS & no Sb/Br)	CU NIPDAU	Level-1-260C-UNLIM	-55 to 125	HK4053	Samples
CD74HCT4053PWRG4	ACTIVE	TSSOP	PW	16	2000	Green (RoHS & no Sb/Br)	CU NIPDAU	Level-1-260C-UNLIM	-55 to 125	HK4053	Samples
CD74HCT4053PWT	ACTIVE	TSSOP	PW	16	250	Green (RoHS & no Sb/Br)	CU NIPDAU	Level-1-260C-UNLIM	-55 to 125	HK4053	Samples

(1) The marketing status values are defined as follows:

ACTIVE: Product device recommended for new designs.

LIFEBUY: TI has announced that the device will be discontinued, and a lifetime-buy period is in effect.

NRND: Not recommended for new designs. Device is in production to support existing customers, but TI does not recommend using this part in a new design.

PREVIEW: Device has been announced but is not in production. Samples may or may not be available.

OBSOLETE: TI has discontinued the production of the device.

(2) **RoHS:** TI defines "RoHS" to mean semiconductor products that are compliant with the current EU RoHS requirements for all 10 RoHS substances, including the requirement that RoHS substance do not exceed 0.1% by weight in homogeneous materials. Where designed to be soldered at high temperatures, "RoHS" products are suitable for use in specified lead-free processes. TI may reference these types of products as "Pb-Free".

RoHS Exempt: TI defines "RoHS Exempt" to mean products that contain lead but are compliant with EU RoHS pursuant to a specific EU RoHS exemption.

Green: TI defines "Green" to mean the content of Chlorine (Cl) and Bromine (Br) based flame retardants meet JS709B low halogen requirements of <=1000ppm threshold. Antimony trioxide based flame retardants must also meet the <=1000ppm threshold requirement.

(3) MSL, Peak Temp. - The Moisture Sensitivity Level rating according to the JEDEC industry standard classifications, and peak solder temperature.

(4) There may be additional marking, which relates to the logo, the lot trace code information, or the environmental category on the device.

(5) Multiple Device Markings will be inside parentheses. Only one Device Marking contained in parentheses and separated by a "~" will appear on a device. If a line is indented then it is a continuation of the previous line and the two combined represent the entire Device Marking for that device.

⁽⁶⁾ Lead/Ball Finish - Orderable Devices may have multiple material finish options. Finish options are separated by a vertical ruled line. Lead/Ball Finish values may wrap to two lines if the finish value exceeds the maximum column width.

Important Information and Disclaimer:The information provided on this page represents TI's knowledge and belief as of the date that it is provided. TI bases its knowledge and belief on information provided by third parties, and makes no representation or warranty as to the accuracy of such information. Efforts are underway to better integrate information from third parties. TI has taken and continues to take reasonable steps to provide representative and accurate information but may not have conducted destructive testing or chemical analysis on incoming materials and chemicals. TI and TI suppliers consider certain information to be proprietary, and thus CAS numbers and other limited information may not be available for release.

In no event shall TI's liability arising out of such information exceed the total purchase price of the TI part(s) at issue in this document sold by TI to Customer on an annual basis.

OTHER QUALIFIED VERSIONS OF CD54HC4051, CD54HC4052, CD54HC4053, CD54HCT4051, CD74HC4051, CD74HC4052, CD74HC4053, CD74HCT4051 :

- Catalog: [CD74HC4051](#), [CD74HC4052](#), [CD74HC4053](#), [CD74HCT4051](#)
- Automotive: [CD74HC4051-Q1](#), [CD74HCT4051-Q1](#), [CD74HC4051-Q1](#), [CD74HCT4051-Q1](#)
- Enhanced Product: [CD74HC4051-EP](#), [CD74HC4051-EP](#)
- Military: [CD54HC4051](#), [CD54HC4052](#), [CD54HC4053](#), [CD54HCT4051](#)

NOTE: Qualified Version Definitions:

- Catalog - TI's standard catalog product
- Automotive - Q100 devices qualified for high-reliability automotive applications targeting zero defects
- Enhanced Product - Supports Defense, Aerospace and Medical Applications
- Military - QML certified for Military and Defense Applications

TAPE AND REEL INFORMATION

QUADRANT ASSIGNMENTS FOR PIN 1 ORIENTATION IN TAPE

*All dimensions are nominal

Device	Package Type	Package Drawing	Pins	SPQ	Reel Diameter (mm)	Reel Width W1 (mm)	A0 (mm)	B0 (mm)	K0 (mm)	P1 (mm)	W (mm)	Pin1 Quadrant
CD74HC4051M96	SOIC	D	16	2500	330.0	16.4	6.5	10.3	2.1	8.0	16.0	Q1
CD74HC4051M96	SOIC	D	16	2500	330.0	16.8	6.5	10.3	2.1	8.0	16.0	Q1
CD74HC4051M96G3	SOIC	D	16	2500	330.0	16.8	6.5	10.3	2.1	8.0	16.0	Q1
CD74HC4051M96G4	SOIC	D	16	2500	330.0	16.4	6.5	10.3	2.1	8.0	16.0	Q1
CD74HC4051PWR	TSSOP	PW	16	2000	330.0	12.4	6.9	5.6	1.6	8.0	12.0	Q1
CD74HC4051PWR	TSSOP	PW	16	2000	330.0	12.4	6.9	5.6	1.6	8.0	12.0	Q1
CD74HC4051PWRG4	TSSOP	PW	16	2000	330.0	12.4	6.9	5.6	1.6	8.0	12.0	Q1
CD74HC4051PWT	TSSOP	PW	16	250	330.0	12.4	6.9	5.6	1.6	8.0	12.0	Q1
CD74HC4052M96	SOIC	D	16	2500	330.0	16.8	6.5	10.3	2.1	8.0	16.0	Q1
CD74HC4052M96	SOIC	D	16	2500	330.0	16.4	6.5	10.3	2.1	8.0	16.0	Q1
CD74HC4052M96G4	SOIC	D	16	2500	330.0	16.4	6.5	10.3	2.1	8.0	16.0	Q1
CD74HC4052NSR	SO	NS	16	2000	330.0	16.4	8.2	10.5	2.5	12.0	16.0	Q1
CD74HC4052PWR	TSSOP	PW	16	2000	330.0	12.4	6.9	5.6	1.6	8.0	12.0	Q1
CD74HC4052PWR	TSSOP	PW	16	2000	330.0	12.4	6.9	5.6	1.6	8.0	12.0	Q1
CD74HC4052PWRG4	TSSOP	PW	16	2000	330.0	12.4	6.9	5.6	1.6	8.0	12.0	Q1
CD74HC4052PWT	TSSOP	PW	16	250	330.0	12.4	6.9	5.6	1.6	8.0	12.0	Q1
CD74HC4053M96	SOIC	D	16	2500	330.0	16.8	6.5	10.3	2.1	8.0	16.0	Q1
CD74HC4053M96	SOIC	D	16	2500	330.0	16.4	6.5	10.3	2.1	8.0	16.0	Q1

Device	Package Type	Package Drawing	Pins	SPQ	Reel Diameter (mm)	Reel Width W1 (mm)	A0 (mm)	B0 (mm)	K0 (mm)	P1 (mm)	W (mm)	Pin1 Quadrant
CD74HC4053M96G3	SOIC	D	16	2500	330.0	16.8	6.5	10.3	2.1	8.0	16.0	Q1
CD74HC4053M96G4	SOIC	D	16	2500	330.0	16.4	6.5	10.3	2.1	8.0	16.0	Q1
CD74HC4053PWR	TSSOP	PW	16	2000	330.0	12.4	6.9	5.6	1.6	8.0	12.0	Q1
CD74HC4053PWR	TSSOP	PW	16	2000	330.0	12.4	6.9	5.6	1.6	8.0	12.0	Q1
CD74HC4053PWRG4	TSSOP	PW	16	2000	330.0	12.4	6.9	5.6	1.6	8.0	12.0	Q1
CD74HC4053PWT	TSSOP	PW	16	250	330.0	12.4	6.9	5.6	1.6	8.0	12.0	Q1
CD74HCT4051M96	SOIC	D	16	2500	330.0	16.4	6.5	10.3	2.1	8.0	16.0	Q1
CD74HCT4052M96	SOIC	D	16	2500	330.0	16.4	6.5	10.3	2.1	8.0	16.0	Q1
CD74HCT4053M96	SOIC	D	16	2500	330.0	16.4	6.5	10.3	2.1	8.0	16.0	Q1
CD74HCT4053PWR	TSSOP	PW	16	2000	330.0	12.4	6.9	5.6	1.6	8.0	12.0	Q1
CD74HCT4053PWR	TSSOP	PW	16	2000	330.0	12.4	6.9	5.6	1.6	8.0	12.0	Q1
CD74HCT4053PWRG4	TSSOP	PW	16	2000	330.0	12.4	6.9	5.6	1.6	8.0	12.0	Q1
CD74HCT4053PWT	TSSOP	PW	16	250	330.0	12.4	6.9	5.6	1.6	8.0	12.0	Q1

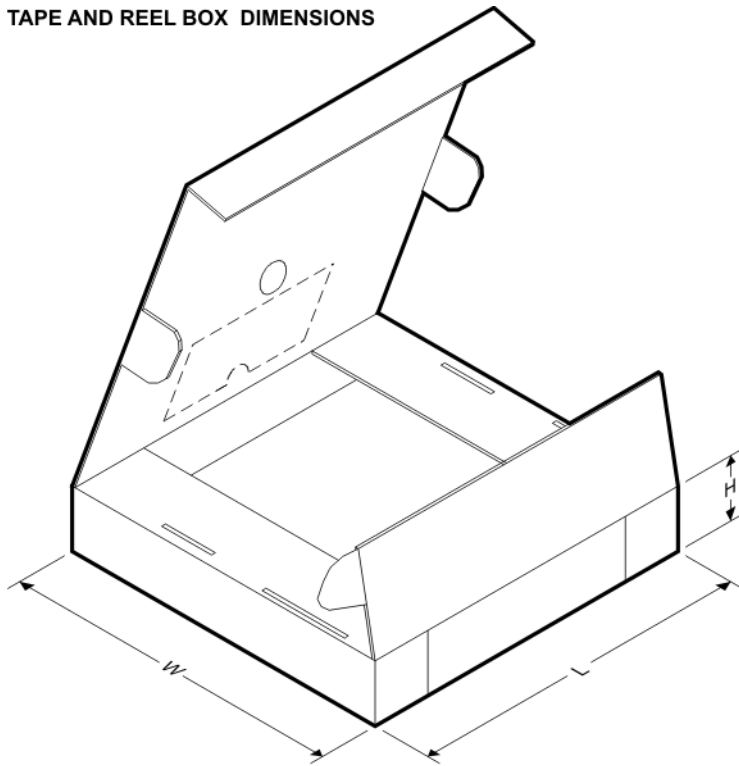
TAPE AND REEL BOX DIMENSIONS

*All dimensions are nominal

Device	Package Type	Package Drawing	Pins	SPQ	Length (mm)	Width (mm)	Height (mm)
CD74HC4051M96	SOIC	D	16	2500	333.2	345.9	28.6
CD74HC4051M96	SOIC	D	16	2500	364.0	364.0	27.0
CD74HC4051M96G3	SOIC	D	16	2500	364.0	364.0	27.0
CD74HC4051M96G4	SOIC	D	16	2500	333.2	345.9	28.6

Device	Package Type	Package Drawing	Pins	SPQ	Length (mm)	Width (mm)	Height (mm)
CD74HC4051PWR	TSSOP	PW	16	2000	367.0	367.0	35.0
CD74HC4051PWR	TSSOP	PW	16	2000	364.0	364.0	27.0
CD74HC4051PWRG4	TSSOP	PW	16	2000	367.0	367.0	35.0
CD74HC4051PWT	TSSOP	PW	16	250	367.0	367.0	35.0
CD74HC4052M96	SOIC	D	16	2500	364.0	364.0	27.0
CD74HC4052M96	SOIC	D	16	2500	333.2	345.9	28.6
CD74HC4052M96G4	SOIC	D	16	2500	333.2	345.9	28.6
CD74HC4052NSR	SO	NS	16	2000	367.0	367.0	38.0
CD74HC4052PWR	TSSOP	PW	16	2000	364.0	364.0	27.0
CD74HC4052PWR	TSSOP	PW	16	2000	367.0	367.0	35.0
CD74HC4052PWRG4	TSSOP	PW	16	2000	367.0	367.0	35.0
CD74HC4052PWT	TSSOP	PW	16	250	367.0	367.0	35.0
CD74HC4053M96	SOIC	D	16	2500	364.0	364.0	27.0
CD74HC4053M96	SOIC	D	16	2500	333.2	345.9	28.6
CD74HC4053M96G3	SOIC	D	16	2500	364.0	364.0	27.0
CD74HC4053M96G4	SOIC	D	16	2500	333.2	345.9	28.6
CD74HC4053PWR	TSSOP	PW	16	2000	367.0	367.0	35.0
CD74HC4053PWR	TSSOP	PW	16	2000	364.0	364.0	27.0
CD74HC4053PWRG4	TSSOP	PW	16	2000	367.0	367.0	35.0
CD74HC4053PWT	TSSOP	PW	16	250	367.0	367.0	35.0
CD74HCT4051M96	SOIC	D	16	2500	333.2	345.9	28.6
CD74HCT4052M96	SOIC	D	16	2500	333.2	345.9	28.6
CD74HCT4053M96	SOIC	D	16	2500	333.2	345.9	28.6
CD74HCT4053PWR	TSSOP	PW	16	2000	364.0	364.0	27.0
CD74HCT4053PWR	TSSOP	PW	16	2000	367.0	367.0	35.0
CD74HCT4053PWRG4	TSSOP	PW	16	2000	367.0	367.0	35.0
CD74HCT4053PWT	TSSOP	PW	16	250	367.0	367.0	35.0

D (R-PDSO-G16)

PLASTIC SMALL OUTLINE



- NOTES:
- A. All linear dimensions are in inches (millimeters).
 - B. This drawing is subject to change without notice.
 - C. Body length does not include mold flash, protrusions, or gate burrs. Mold flash, protrusions, or gate burrs shall not exceed 0.006 (0,15) each side.
 - D. Body width does not include interlead flash. Interlead flash shall not exceed 0.017 (0,43) each side.
 - E. Reference JEDEC MS-012 variation AC.

D (R-PDSO-G16)

PLASTIC SMALL OUTLINE

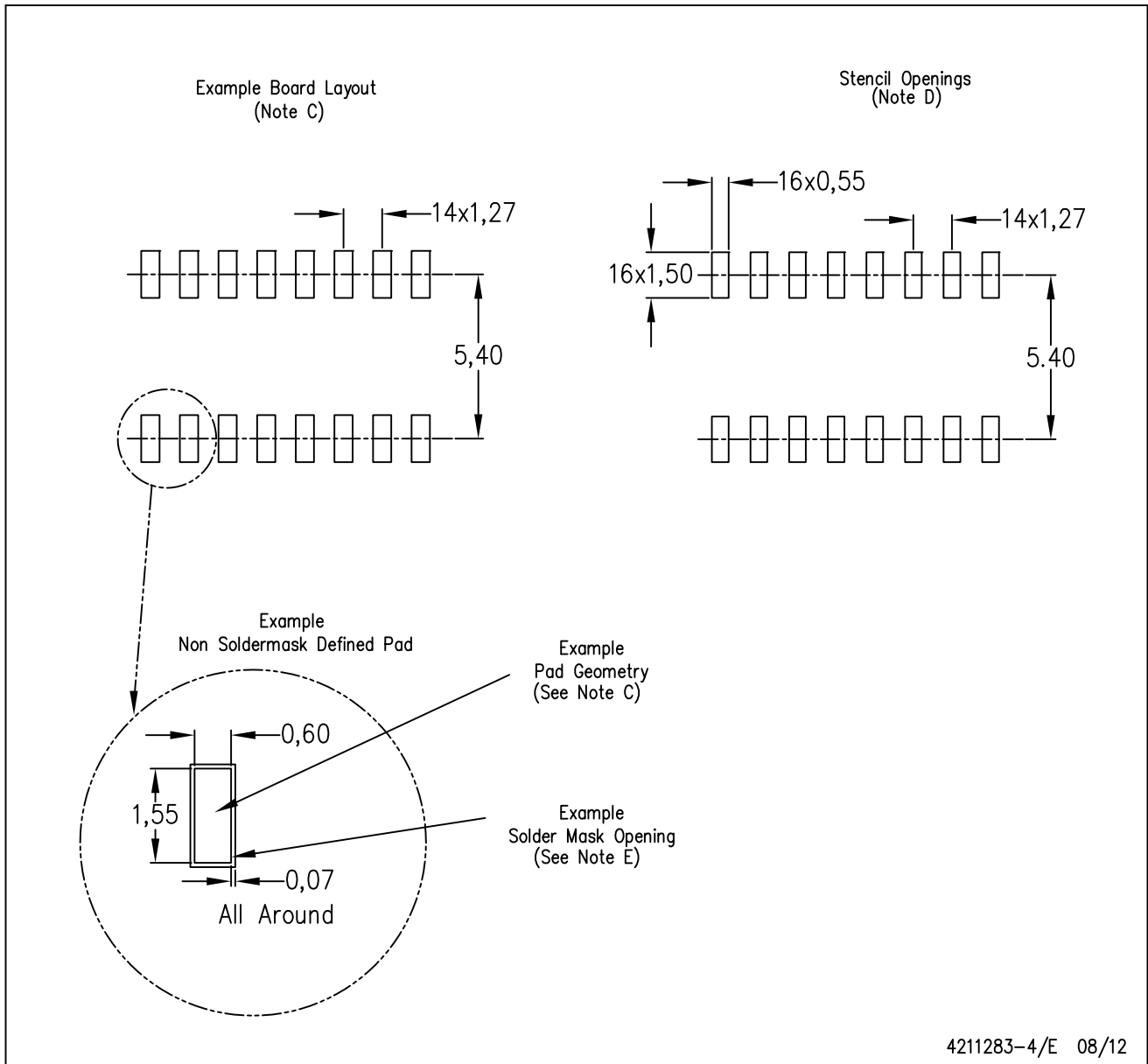

- NOTES:
- A. All linear dimensions are in millimeters.
 - B. This drawing is subject to change without notice.
 - C. Publication IPC-7351 is recommended for alternate designs.
 - D. Laser cutting apertures with trapezoidal walls and also rounding corners will offer better paste release. Customers should contact their board assembly site for stencil design recommendations. Refer to IPC-7525 for other stencil recommendations.
 - E. Customers should contact their board fabrication site for solder mask tolerances between and around signal pads.

PW0016A



PACKAGE OUTLINE

TSSOP - 1.2 mm max height

SMALL OUTLINE PACKAGE

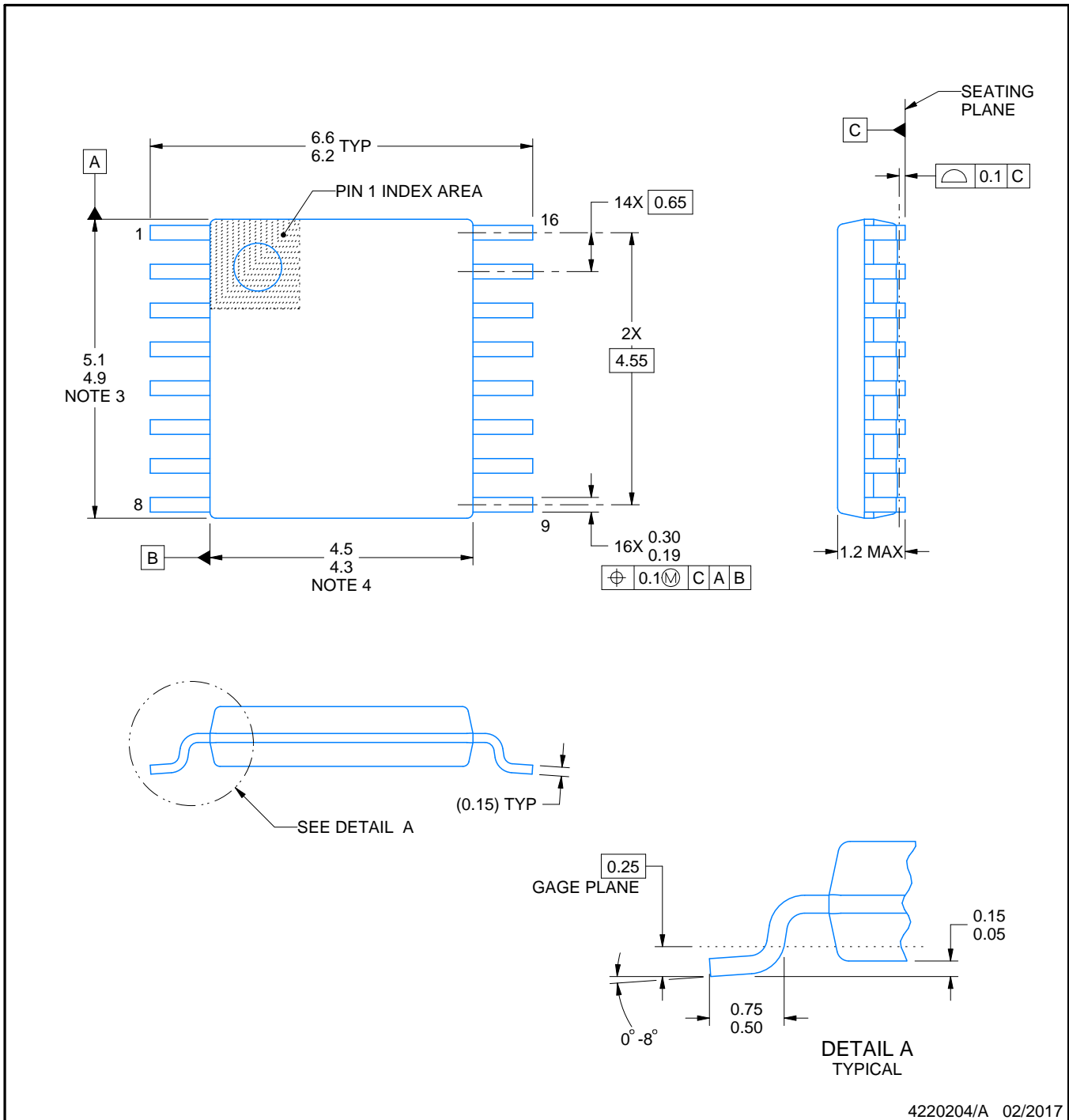

4220204/A 02/2017

NOTES:

- All linear dimensions are in millimeters. Any dimensions in parenthesis are for reference only. Dimensioning and tolerancing per ASME Y14.5M.
- This drawing is subject to change without notice.
- This dimension does not include mold flash, protrusions, or gate burrs. Mold flash, protrusions, or gate burrs shall not exceed 0.15 mm per side.
- This dimension does not include interlead flash. Interlead flash shall not exceed 0.25 mm per side.
- Reference JEDEC registration MO-153.

EXAMPLE BOARD LAYOUT

PW0016A

TSSOP - 1.2 mm max height

SMALL OUTLINE PACKAGE



LAND PATTERN EXAMPLE
EXPOSED METAL SHOWN
SCALE: 10X



SOLDER MASK DETAILS

4220204/A 02/2017

NOTES: (continued)

- 6. Publication IPC-7351 may have alternate designs.
- 7. Solder mask tolerances between and around signal pads can vary based on board fabrication site.

EXAMPLE STENCIL DESIGN

PW0016A

TSSOP - 1.2 mm max height

SMALL OUTLINE PACKAGE



SOLDER PASTE EXAMPLE
BASED ON 0.125 mm THICK STENCIL
SCALE: 10X

4220204/A 02/2017

NOTES: (continued)

8. Laser cutting apertures with trapezoidal walls and rounded corners may offer better paste release. IPC-7525 may have alternate design recommendations.
9. Board assembly site may have different recommendations for stencil design.

MECHANICAL DATA

NS (R-PDSO-G**)

PLASTIC SMALL-OUTLINE PACKAGE

14-PINS SHOWN

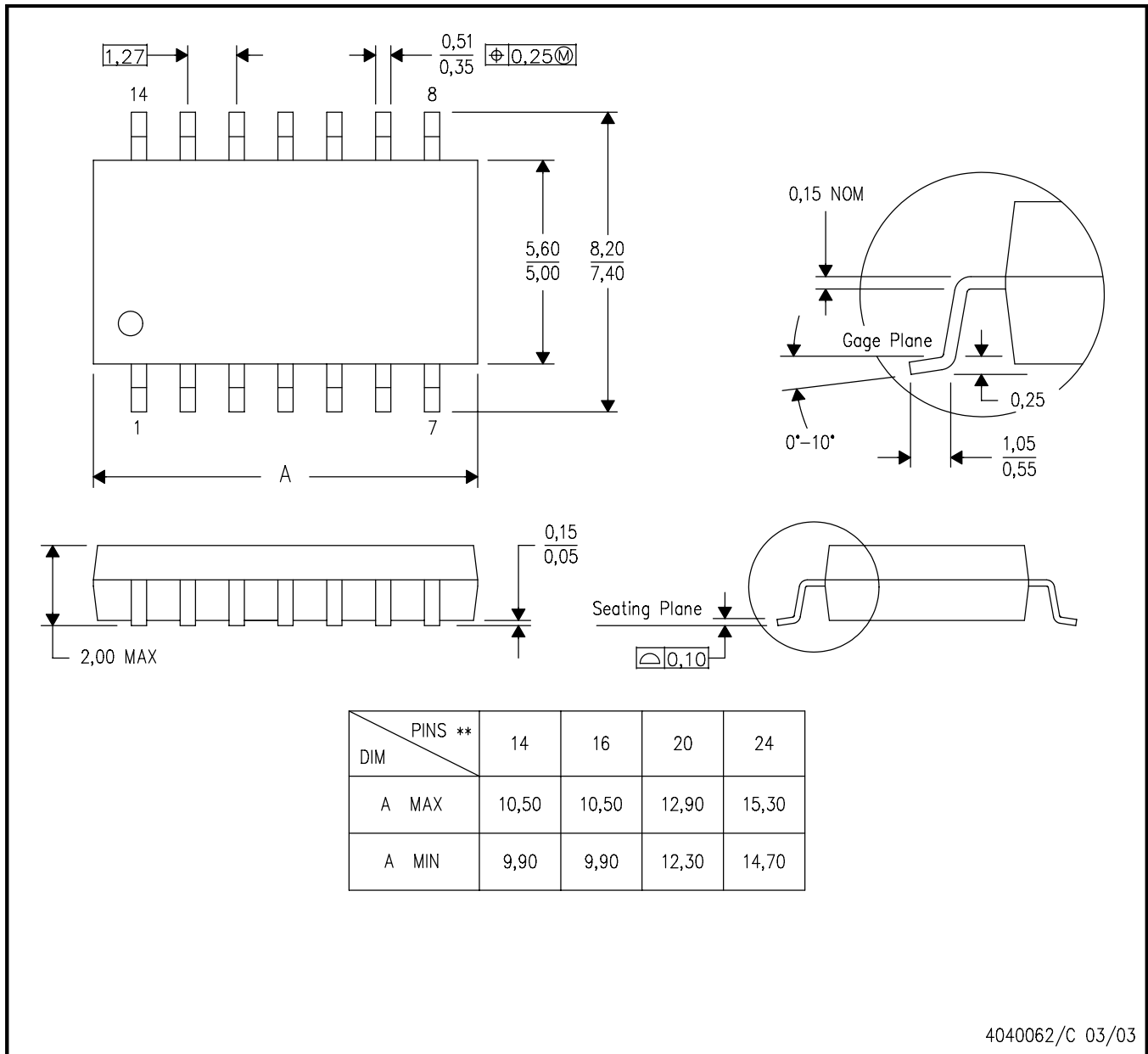

- NOTES:
- A. All linear dimensions are in millimeters.
 - B. This drawing is subject to change without notice.
 - C. Body dimensions do not include mold flash or protrusion, not to exceed 0,15.

J (R-GDIP-T**)

14 LEADS SHOWN

CERAMIC DUAL IN-LINE PACKAGE



DIM \ PINS **	14	16	18	20
A	0.300 (7,62) BSC	0.300 (7,62) BSC	0.300 (7,62) BSC	0.300 (7,62) BSC
B MAX	0.785 (19,94)	.840 (21,34)	0.960 (24,38)	1.060 (26,92)
B MIN	—	—	—	—
C MAX	0.300 (7,62)	0.300 (7,62)	0.310 (7,87)	0.300 (7,62)
C MIN	0.245 (6,22)	0.245 (6,22)	0.220 (5,59)	0.245 (6,22)



4040083/F 03/03

- NOTES:
- A. All linear dimensions are in inches (millimeters).
 - B. This drawing is subject to change without notice.
 - C. This package is hermetically sealed with a ceramic lid using glass frit.
 - D. Index point is provided on cap for terminal identification only on press ceramic glass frit seal only.
 - E. Falls within MIL STD 1835 GDIP1-T14, GDIP1-T16, GDIP1-T18 and GDIP1-T20.

N (R-PDIP-T**)

PLASTIC DUAL-IN-LINE PACKAGE

16 PINS SHOWN

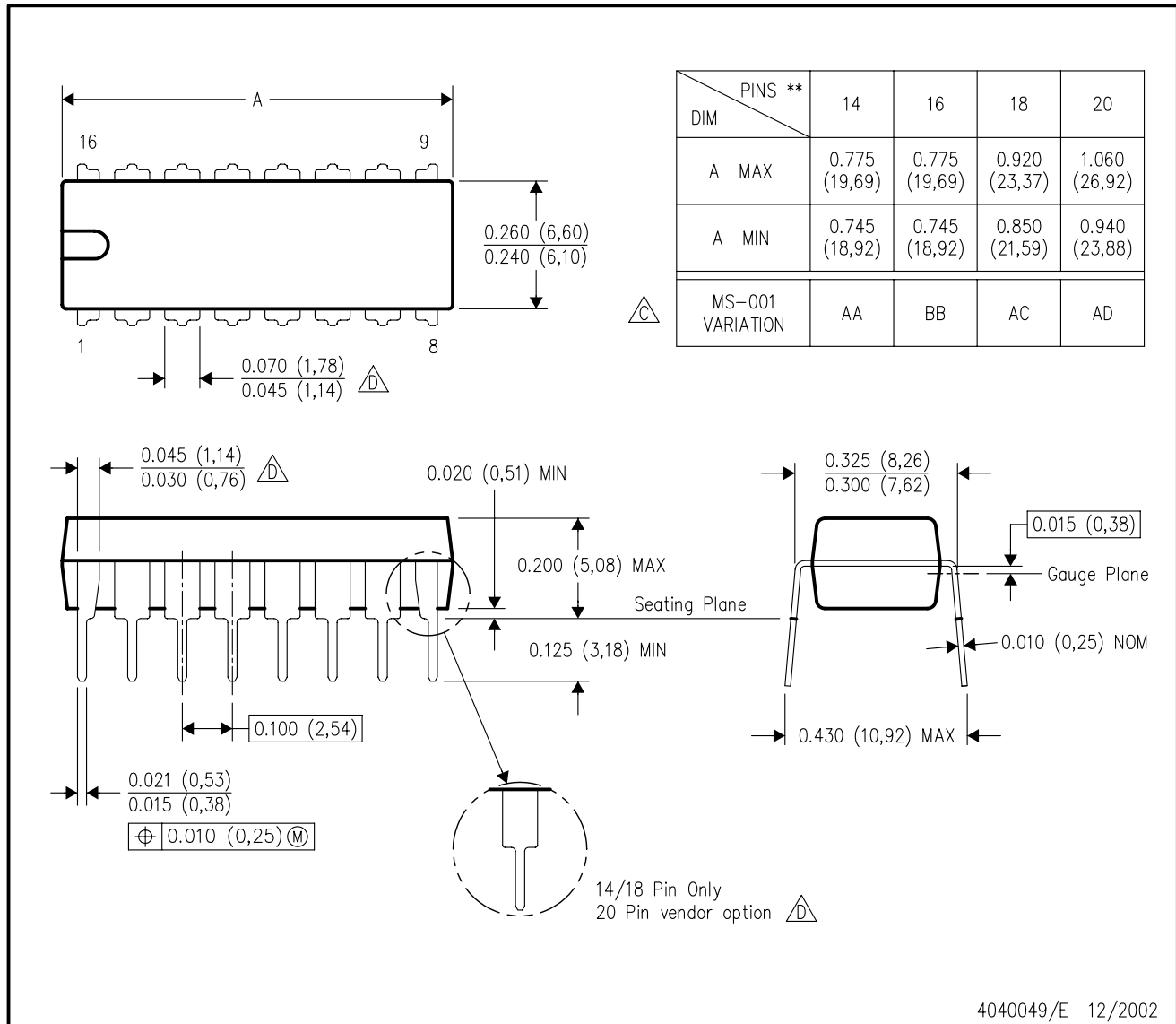

4040049/E 12/2002

- NOTES:
- A. All linear dimensions are in inches (millimeters).
 - B. This drawing is subject to change without notice.
 - (C) Falls within JEDEC MS-001, except 18 and 20 pin minimum body length (Dim A).
 - (D) The 20 pin end lead shoulder width is a vendor option, either half or full width.

IMPORTANT NOTICE AND DISCLAIMER

TI PROVIDES TECHNICAL AND RELIABILITY DATA (INCLUDING DATASHEETS), DESIGN RESOURCES (INCLUDING REFERENCE DESIGNS), APPLICATION OR OTHER DESIGN ADVICE, WEB TOOLS, SAFETY INFORMATION, AND OTHER RESOURCES "AS IS" AND WITH ALL FAULTS, AND DISCLAIMS ALL WARRANTIES, EXPRESS AND IMPLIED, INCLUDING WITHOUT LIMITATION ANY IMPLIED WARRANTIES OF MERCHANTABILITY, FITNESS FOR A PARTICULAR PURPOSE OR NON-INFRINGEMENT OF THIRD PARTY INTELLECTUAL PROPERTY RIGHTS.

These resources are intended for skilled developers designing with TI products. You are solely responsible for (1) selecting the appropriate TI products for your application, (2) designing, validating and testing your application, and (3) ensuring your application meets applicable standards, and any other safety, security, or other requirements. These resources are subject to change without notice. TI grants you permission to use these resources only for development of an application that uses the TI products described in the resource. Other reproduction and display of these resources is prohibited. No license is granted to any other TI intellectual property right or to any third party intellectual property right. TI disclaims responsibility for, and you will fully indemnify TI and its representatives against, any claims, damages, costs, losses, and liabilities arising out of your use of these resources.

TI's products are provided subject to TI's Terms of Sale (www.ti.com/legal/termsofsale.html) or other applicable terms available either on ti.com or provided in conjunction with such TI products. TI's provision of these resources does not expand or otherwise alter TI's applicable warranties or warranty disclaimers for TI products.

Mailing Address: Texas Instruments, Post Office Box 655303, Dallas, Texas 75265
Copyright © 2019, Texas Instruments Incorporated

Looking for pricing, stock, or lifecycle information?

Click below to explore more details on WIN SOURCE:

 [View CD74HCT4051M96 on WIN SOURCE](#)

 [Texas Instruments](#) Information

Optimize Your Supply Chain with WIN SOURCE Solutions

-  Global Sourcing Solution
-  Obsolete Management
-  Cost Control Management
-  Shortage Management
-  Alternative Solution
-  Excess Inventory Management