



**THE DATASHEET OF  
MBC450-1T12G**



# MBC450 Series

## AC-DC Open Frame Power Supplies Medical

Not For New Design  
Please refer to exact equivalent product series  
**MWLT450**

The MBC450 Series of open-frame medical power supplies, with its wide universal 90-264 VAC input range, is available at 450 W of output power and a variety of single output voltages.

The MBC series is designed and approved to the latest Medical standards (EN/IEC 60601-1), providing 2 x MOPP isolation for Class I applications.

These medical power supplies are ideal for monitoring, home health equipment as well as surgical devices.

### Key Features & Benefits

- 4 x 6.5 x 1.61 inches
- Approved to EN/IEC 60601-1
- Dual Fusing
- Peak Power Capability
- Class B EMI & Medical (BF) Safety Approvals
- Side Fan or Top Fan Mounting Option
- Current Sharing Option
- Class B EMI & Medical (BF) Safety Approvals
- RoHS Compliant
- CE marked

### Applications

- Diagnostic
- Drug Pump
- Dialysis
- Hospital Beds
- Home Health Care
- Monitoring
- Imaging
- Therapy Devices



**bel** POWER  
SOLUTIONS &  
PROTECTION

a bel group

[belfuse.com/power-solutions](http://belfuse.com/power-solutions)

## 1. MODEL SELECTION

MODEL <sup>1</sup>	OUTPUT VOLTAGE	MAX LOAD		MINIMUM LOAD	RIPPLE & NOISE <sup>2</sup>	POWER
		CONVECTION	420 LFM			
MBC450-1T05G	5 VDC	31.0 A	55.0 A	0.0 A	2%	275 W
MBC450-1T12G	12 VDC	20.83 A	37.5 A	0.0 A	2%	450 W
MBC450-1T15G	15 VDC	16.66 A	30.0 A	0.0 A	2%	450 W
MBC450-1T24G	24 VDC	12.30 A	18.75 A	0.0 A	2%	450 W
MBC450-1T30G	30 VDC	10.0 A	15.0 A	0.0 A	2%	450 W
MBC450-1T48G	48 VDC	6.25 A	9.37 A	0.0 A	2%	450 W

<sup>1</sup> For Side Fan Mounting option, add suffix -S to the part number (e.g.: MBC450-1T12G-S)

For Top Fan Mounting option add suffix -T to the part number (e.g.: MBC450-1T24G-T)

For Current Sharing option, add suffix -I to the part number (e.g.: MBC450-1T48G-I or MBC450-1T48G-I-S)

<sup>2</sup> Ripple is peak to peak with 20 MHz bandwidth and 10  $\mu$ F (Electrolytic capacitor) in parallel with a 0.1  $\mu$ F capacitor at rated line voltage and load ranges. Please contact factory/ sales representative for minimum load required for ripple to be within specification.

## 2. INPUT SPECIFICATIONS

Specifications are for nominal input voltage, 25°C unless otherwise stated.

PARAMETER	DESCRIPTION / CONDITION	SPECIFICATIONS
Input Voltage	Universal	90 – 264 VAC / 120 – 390 VDC
Input Frequency		47 – 63 Hz
Input Current	120 VAC: 230 VAC:	4.5 A max. 2.3 A max.
No Load Power	120 VAC: 230 VAC:	0.4 W 0.8 W
Inrush Current	120 VAC: 230 VAC:	40 A max. 75 A max.
Leakage Current	Earth Leakage Current Touch Leakage Current	270 $\mu$ A 45 $\mu$ A @ 120 VAC / 63 Hz
Input Protection	Dual fusing, in Live & Neutral	T8A / 250 V
No Load Power	120 VAC: 230 VAC:	0.4 0.3
Switching Frequency	PFC converter: Variable Resonant converter: Variable	45 – 160 kHz typical 35 – 250 kHz, 90 kHz typical

### 3. OUTPUT SPECIFICATIONS

PARAMETER	DESCRIPTION / CONDITION		SPECIFICATIONS
Output Voltage			5 to 48 V
Output Power <sup>3,4</sup>	475 W for 24 V, 30 V models & 500 W for 48 V model only for 5 seconds max.		155 to 450 W
Standby Output <sup>5</sup>			5 VDC
Fan Output <sup>6</sup>			12 V
Efficiency (Full Load)	120 VAC	24, 30 & 48 V models 12 & 15 V models 5 V model	88% 86% 83% typical
	230 VAC	24, 30 & 48 V models	90%
Hold Up Time	120 / 230 VAC		10 ms
Power Factor	120 VAC		0.98
	230 VAC		0.95
Line Regulation			± 0.5%
Load Regulation			± 3%
Transient Response	<10%, 50% to 100% load change, 50 Hz, 50% duty cycle, 0.1 A/μs		Recovery time < 5 ms
Rise Time			< 100 ms
Set Point Tolerance			± 1%
Output Voltage Adjustment	V1		± 3 %
Over Voltage Protection	Latch Type		>114%
Over Current Protection	Hiccup type		120 to 150%
Short Circuit Protection	Short term, auto recovery		
Over Temperature Protection	Automatic recovery		130°C primary heat sink
Current Share	Up to 2 supplies connected in parallel (optional)		
Cooling	Convection	5 V model	155 W
		12 & 15 V models	250 W
		24, 30 & 48 V models	300 W
	With 420 LFM	5 V model	275 W
	12 & 15 V models	450 W	
	24, 30 & 48 V models	450 W	

<sup>3</sup> Combined output power of main output, fan supply and standby supply shall not exceed max. power rating.

<sup>4</sup> Derate output power linearly to 80% from 90 VAC to 80 VAC input.

<sup>5</sup> Standby output voltage 5 V / 1.5 A (convection) / 2 A (420 LFM) with tolerance including set point accuracy, line & load regulation is +/-10%. Ripple and noise is less than 5%.

<sup>6</sup> Fan supply output voltage 12V / 500 mA with tolerance including set point accuracy, line and load regulation is +/-30% and needs min. 1% load on main output to be within regulation band. Ripple and noise is less than 10%.

### 4. SIGNALS

PARAMETER	DESCRIPTION / CONDITION
Power Good Signal	TTL signal goes high after main output is within regulation band, delay is 0.1 to 0.3 s
Remote Sense	Compensates for 200 mV drop
Remote on/off	To turn on PSU short remote pin to ground

## 5. EMC SPECIFICATIONS

PARAMETER	DESCRIPTION / CONDITION	SPECIFICATION
Conducted Emissions	EN 55011-B, CISPR22-B, FCC PART15-B	Pass
Radiated Emissions	EN 55011 B	Pass
Input Current Harmonics	EN 61000-3-2	Class D
Voltage Fluctuation and Flicker	EN 61000-3-3	Pass
ESD Immunity	EN 61000-4-2	Level 4, Criterion A
Radiated Field Immunity	EN 61000-4-3	Level 3, Criterion A
Electrical Fast Transient Immunity	EN 61000-4-4	Level 3, Criterion A
Surge Immunity	EN 61000-4-5	Level 3, Criterion A
Conducted Immunity	EN 61000-4-6	Level 3, Criterion A
Magnetic Field Immunity	EN 61000-4-8	Level 4, Criterion A
Voltage Dips, Interruptions	EN 61000-4-11	Criterion A & B

## 6. SAFETY SPECIFICATIONS

PARAMETER	DESCRIPTION / CONDITION	SPECIFICATION
Isolation Voltage	Input to Output, 2MOPP	5940 VDC
	Input to Earth, 1MOPP	2121 VDC
	Output to GDN for type BF	1500 VAC
Safety Standards	EN 60601-1, IEC 60601-1 (ed.3), ANSI / AAMI ES 60601 - 1, CSA C22.2 No. 60601-1	
Agency Approvals	Nemko, UL, C-UL	
CE mark	Complies with LVD Directive	

## 7. ENVIRONMENTAL SPECIFICATIONS

PARAMETER	DESCRIPTION / CONDITION	SPECIFICATIONS
Operating Temperature	Refer to derating curves -20 to 0°C, start-up is guaranteed	0 to +70°C
Storage Temperature		-40 to 85° C
Humidity	Non-Condensing	95% HR
Altitude	Operating:	10,000 ft.
	Non-Operating:	40,000 ft.
Reliability	MTBF according to Telcordia -SR332-Issue 3	1.28 million hours

## DERATING CURVES

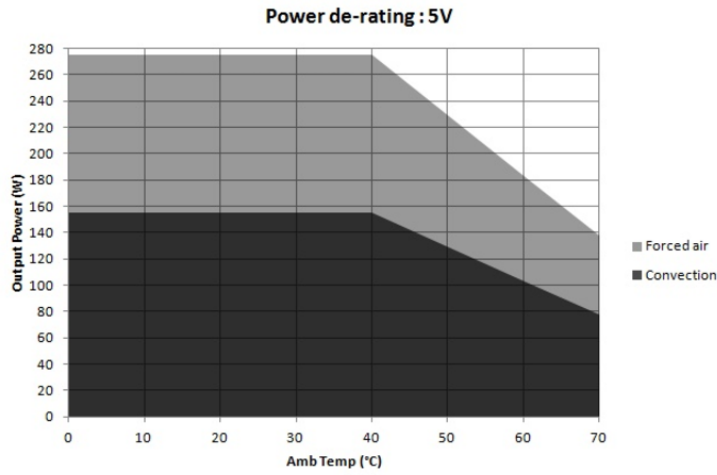

Convection load: 155 W up to 40 °C  
De-rate above 40 °C @ 1.67% per °C

Forced air cooled load: 275 W up to 40°C  
De-rate above 40 °C @ 1.67% per °C

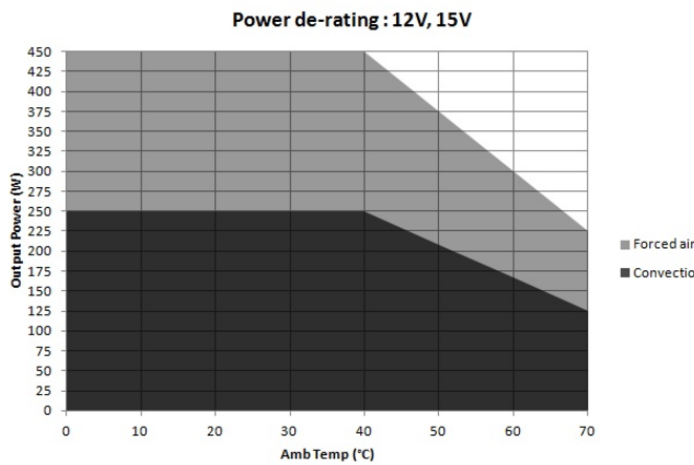

Convection load: 250 W up to 40 °C  
De-rate above 40 °C @ 1.67% per °C

Forced air cooled load: 450 W up to 40°C  
De-rate above 40 °C @ 1.67% per °C

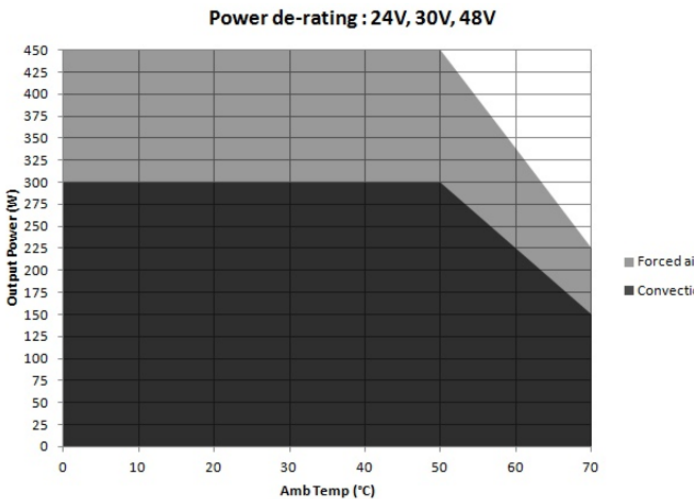

Convection load: 300 W up to 50 °C  
De-rate above 50 °C @ 2.5% per °C

Forced air cooled load: 450 W up to 50°C  
De-rate above 50 °C @ 2.5% per °C

Figure 1. Derating Curves

## 8. CONNECTOR & PIN DESCRIPTION

CONNECTOR	PIN	DESCRIPTION / CONDITION	MANUFACTURER / PN
AC Input Connector	J1	Pin 1 Pin 3 Pin 5	AC line AC neutral Earth
DC Output Connector	J2	Lug 1 Lug 2	+V1 RTN
Signals <sup>7</sup>	J3	Pin 1 Pin 2 Pin 3 Pin 4 Pin 5 Pin 6 Pin 7 Pin 8 Pin 9 Pin 10	NC Power Fail Power Good DC Return +5Vstby +VE Remote Sense -VE Remote Sense CS DC Return Remote On/Off
Fan	J4	Pin 1 Pin 2	+VE -VE
Earth (Spade Connector) <sup>8</sup>	J5		

<sup>7</sup> PSU is supplied with J3 housing, pin-9 and pin-10 shorted to enable main output without remote on/off feature.

<sup>8</sup> The J5 (Earth) spade connector can be used for U-Channel option products only. When fan options are required the earth connection provided in the input AC connector should be used (Pin 5 – J1)

## 9. MECHANICAL SPECIFICATIONS

PARAMETER	DESCRIPTION / CONDITION
Weight	900 g (1.98 lbs)
Dimensions	101.6 x 165.0 x 41.0 mm (4.0 x 6.5 x 1.6 in)

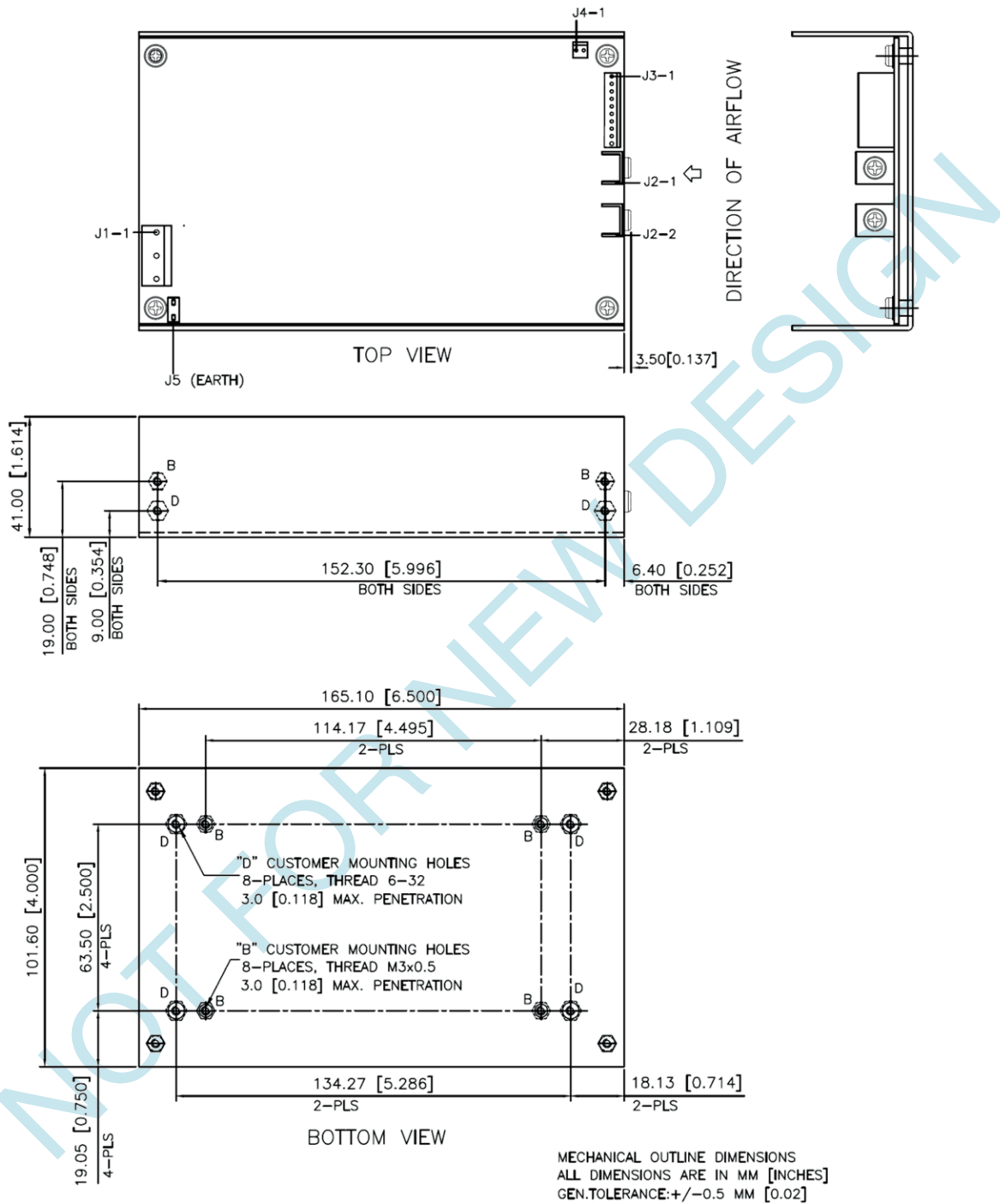

Figure 2. Mechanical Drawing (Without Fan Mounting)

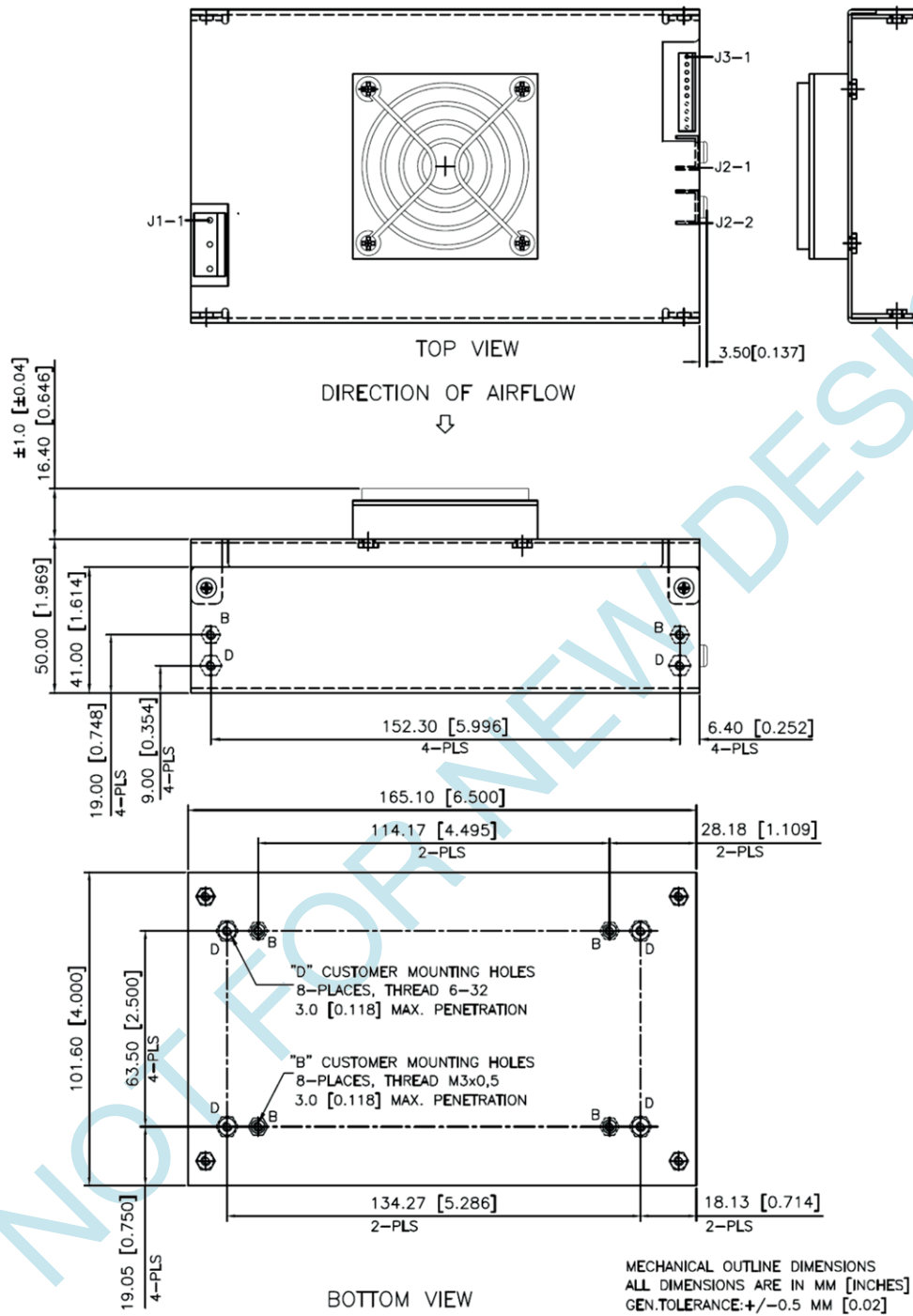

Figure 3. Mechanical Drawing (With Top Fan Mounting)

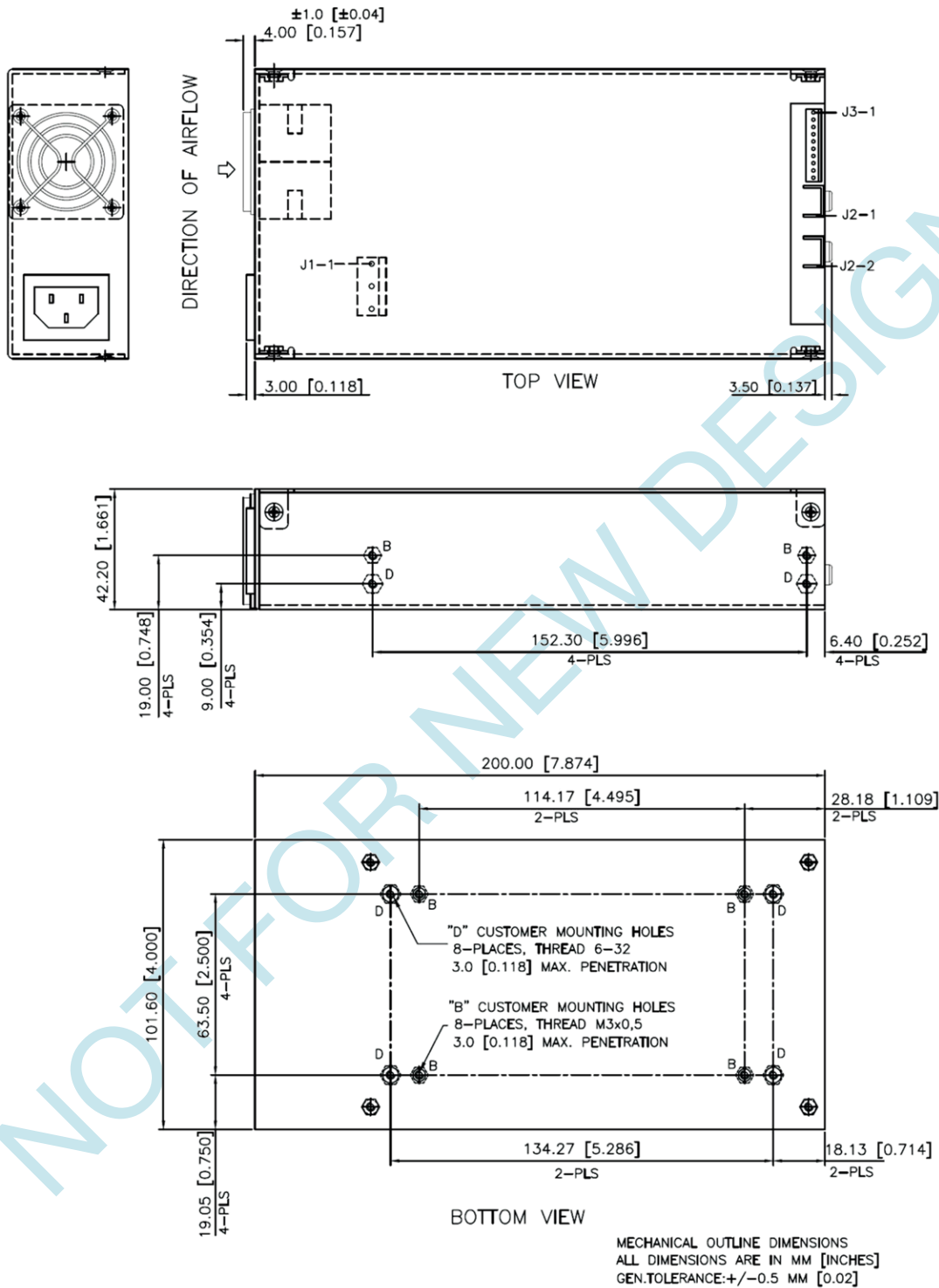

Figure 4. Mechanical Drawing (With Side Fan Mounting)

## 10. INSTALLATION INSTRUCTION FOR CURRENT SHARING

During the installation and setup of parallel supplies in a system it is important that a single remote sense point be used for all the supplies.

The remote sense voltage between the supplies must be adjusted to within 2% to ensure the supplies are inside the 3% capture window.

If the supplies are not initially adjusted inside the capture window the supplies will not current share.

### NOTE:

“CURRENT SHARING” facility is inclusive with the unit only with ordering of the “CURRENT SHARING” option by adding suffix -I to the part number, i.e. MBC450-1XXX-I or MBC450-1XXX-I.

### SET-UP PROCEDURE:

- 1 Connect load cables to the outputs of each supply.
- 2 Connect the remote sense lines to the load in twisted style. (A common remote sense point must be used for all the supplies in parallel).
- 3 Connect all the “current share” pins on the J3 connector between the supplies.
- 4 Adjust remote sense voltage of each supply to within 1% of rated output voltage or readjust to required set point. (Adjustment to be done with all other parallel supplies off).
- 5 Current sharing between the supplies can be verified by monitoring the output current of each supply with a hall effect DC current probe. The supplies should share to within 10% of the total load current.
- 6 The current share circuit has a capture window voltage of +/- 3% of the rated output voltage. If the output remote sense voltage of one of the supplies is adjusted outside the 3% window the supplies will not current share.

**CURRENT SHARING BLOCK DIAGRAM**

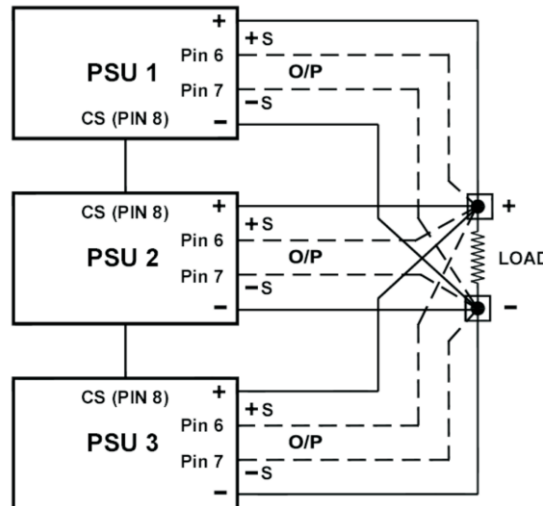

**For more information on these products consult: [tech.support@psbel.com](mailto:tech.support@psbel.com)**

**NUCLEAR AND MEDICAL APPLICATIONS** - Products are not designed or intended for use as critical components in life support systems, equipment used in hazardous environments, or nuclear control systems.

**TECHNICAL REVISIONS** - The appearance of products, including safety agency certifications pictured on labels, may change depending on the date manufactured. Specifications are subject to change without notice.

## Looking for pricing, stock, or lifecycle information?

Click below to explore more details on WIN SOURCE:

 [View MBC450-1T12G on WIN SOURCE](#)

 [Bel Power Solutions Information](#)

## Optimize Your Supply Chain with WIN SOURCE Solutions

-  Global Sourcing Solution
-  Obsolete Management
-  Cost Control Management
-  Shortage Management
-  Alternative Solution
-  Excess Inventory Management