



**THE DATASHEET OF
ECS-MPI2520R1-100-R**



Rev. : B

DATE : DEC. 15. 2017

ECS-MPI2520

SMD Power Inductor



Part No

ECS-MPI2520R0/R1

Rev.

B

1. Shape and Dimension(mm)

1) Shape

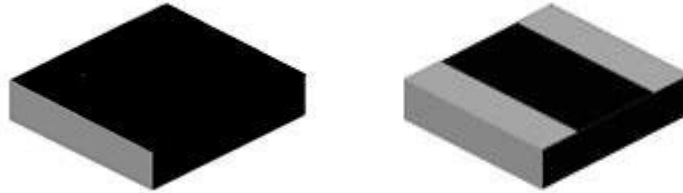

2) Dimensions(mm)

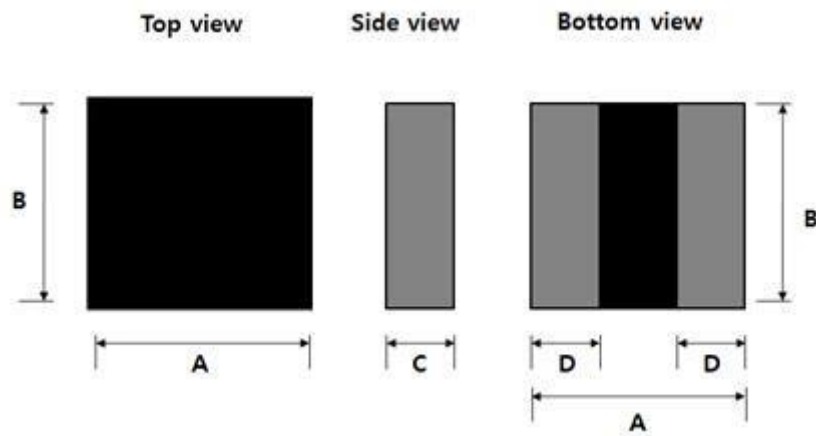

Item	A(mm)	B(mm)	C(mm)	D(mm)
ECS-MPI2520R0	2.5 ±0.2	2.0 ± 0.2	1.0 max	0.6 ± 0.25
ECS-MPI2520R1	2.5 ±0.2	2.0 ± 0.2	1.2 max	0.6 ± 0.25

Revision History

Write

Review

Approval

NO	Note	Date	Write	Review	Approval
1	Initial Release	2017. 6. 01			
2	Revised height indicator in PN	2017. 12. 15			

2. Schematic & Land Pattern

1) Schematics

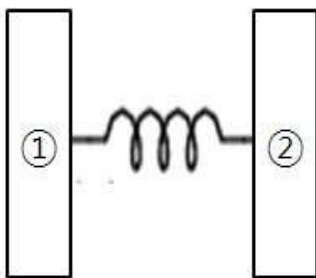

2) Land Pattern(mm)

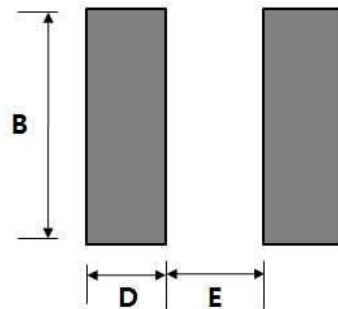

B	2.2mm
D	0.8mm
E	1.2mm

3. Material List & Terminal Construction

1) Material List

No	Materials
1	Fe-Si Powder
2	Cu wire
3	Epoxy(Black)
4	Cu
5	Ni
6	Sn

2) Terminal Construction

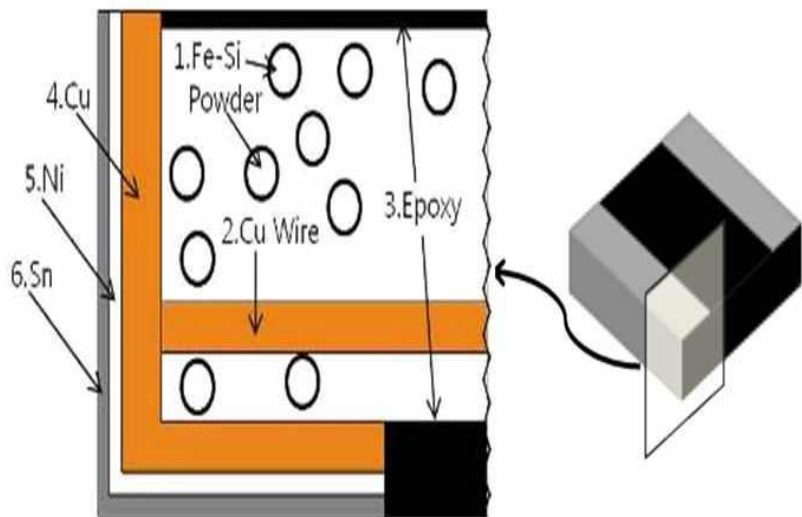

DATA SHEET

PAGE

3 / 10

Part No

ECS-MPI2520R0/R1

Rev.

B

4. Electrical Performance

1) Test condition : 1MHz, 0.10V

2) DCR @ 25°C

Part Number	Code Note a	OCL (uH) ± 20% Note b	Isat (A) Note d	Irms (A) Note f	DCR (mΩ) (Typ)	DCR (mΩ) (max) Note g	K-factor
ECS-MPI2520R0-R47-R	B	0.47	4.4	4.1	28	33.6	2887
ECS-MPI2520R0-1R0-R	C	0.9	3.2	3.2	50	60	1925
ECS-MPI2520R0-1R5-R	D	1.5	2.6	2.4	80	96	1444
ECS-MPI2520R0-2R2-R	E	2.2	2.4	2.2	103	123.6	1283
ECS-MPI2520R0-3R3-3	F	3.3	1.6	1.6	190	228	1050
ECS-MPI2520R0-4R7-R	G	4.7	1.4	1.4	240	288	825
ECS-MPI2520R1-R47-R	A	0.47	4.8	4.5	20	24	2310
ECS-MPI2520R1-1R0-R	B	1	4	3.7	35	42	1925
ECS-MPI2520R1-1R5-R	C	1.5	3.4	2.9	55	66	1444
ECS-MPI2520R1-2R2-R	D	2.2	2.7	2.3	75	90	1255
ECS-MPI2520R1-3R3-R	E	3.3	2.4	1.8	105	126	962
ECS-MPI2520R1-4R7-R	F	4.7	1.9	1.6	150	180	825
ECS-MPI2520R1-5R6-R	G	5.6	1.5	1.5	200	240	679
ECS-MPI2520R1-6R8-R	H	6.8	1.3	1.3	300	360	679
ECS-MPI2520R1-100-R	I	10	1.2	1.1	390	468	525

Measuring Instruments:

OCL: HP4284A (Agilent Technologies, or equivalent)

DC Bias: HP4284A & HP42841B (Agilent Technologies, or equivalent)

DC Resistance: 4100ATC (or equivalent)

Note a: Print Marking Code on each reel of product to define different part number.

Note b: Test condition: 1MHz, 0.1V

Note c: Test condition: 1 MHz, 0.1V

Noted: Isat Amperes Peak for approximately 30% Roll-off (@25°C)

Note f: RMS current for an approximate ΔT of 40°C without core loss. It is recommended that the temperature of the part does not exceed 125°C.

Note g: DCR @ 25°C.

5. Electrical characteristics(Graph)

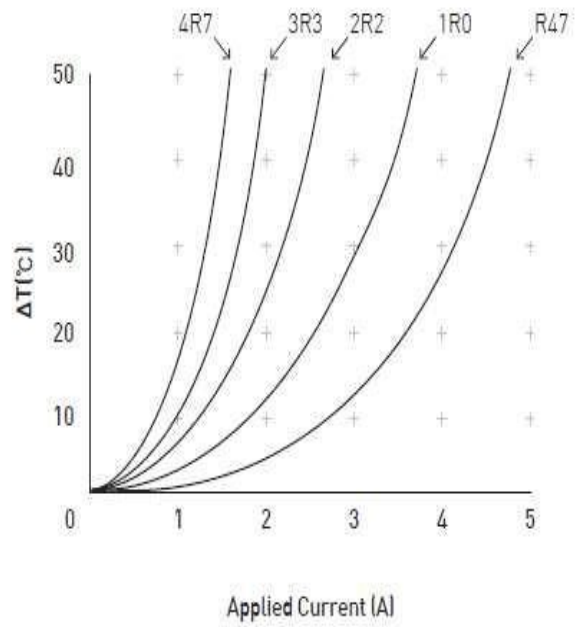
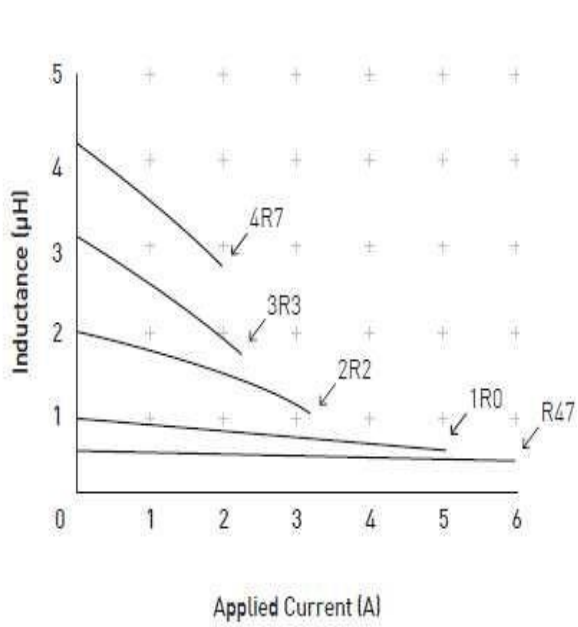

ECS-MPI2520R0

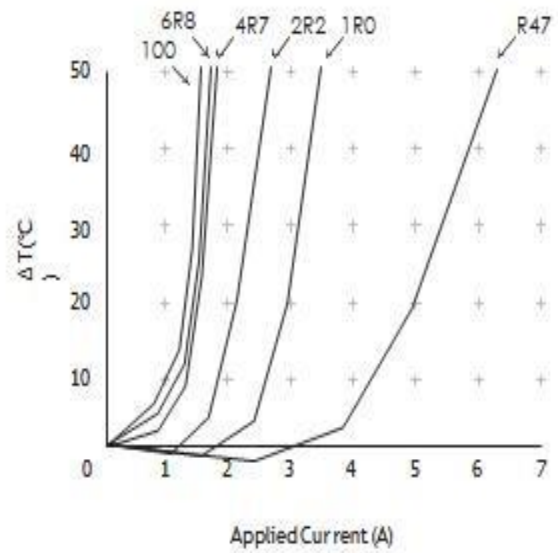
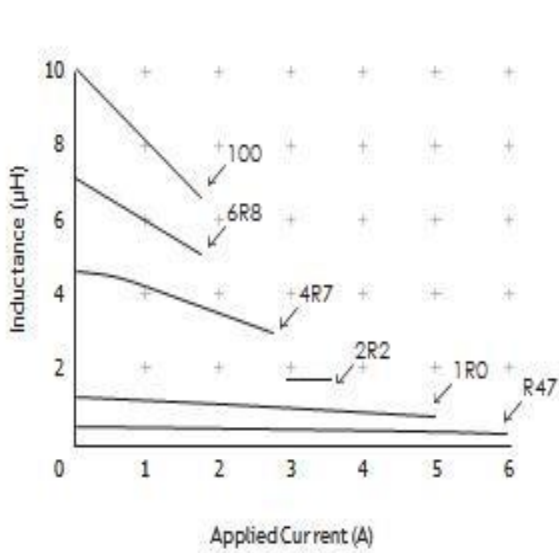

ECS-MPI2520R1

6. Mechanical characteristics testing items

- 1) Storage temperature $-40 \sim +105^{\circ}\text{C}$
- 2) Operation Temperature $-40 \sim +105^{\circ}\text{C}$ (Including coil's self-temperature rise)
- 3) External appearance: No external defects can be found in the visual inspection.
- 4) Electrode strength

No electrode detachment should be found when the device is pushed in two directions of X and Y with the force of 5.0N for 60 ± 1 seconds after soldering between copper plate and the electrodes. (Refer to figure)

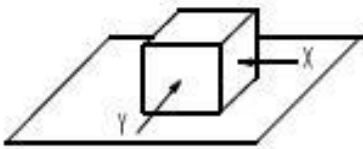

5) Heat endurance test

Inductance deviation is within $\pm 5.0\%$ after reflow test be done for 3 times. according to the below chart, then the measurement shall be made in 2 hours after 1 hour storage under room ambient conditions

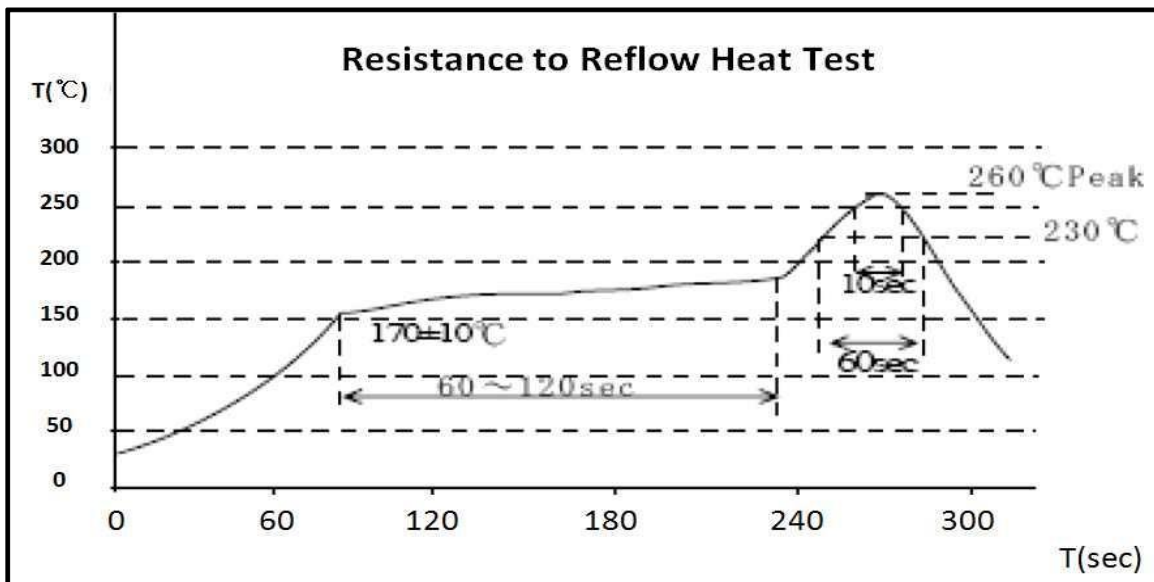

6) Vibration test

Inductance deviation is within $\pm 5.0\%$ after 2 hour sweeping vibration in each three directions, namely, forward and backward, up and down, right and left. The frequency is $10 \sim 55 \sim 10\text{Hz}$ and amplitude of 1 minute cycles is 1.5mm PP.

7) Shock test

Inductance deviation is within $\pm 5.0\%$ after the test with gum-block shock testing machine, once in each of the three perpendicular axis directions. The shock acceleration is 981m/s^2

DATA SHEET		PAGE	6 / 10
Part No	ECS-MPI2520R0/R1	Rev.	B

8) Humidity test

Inductance deviation is within $\pm 5.0\%$ after 500 ± 12 hours test under the condition of relative humidity of 90~95% and temperature of $60 \pm 2^\circ\text{C}$. and 1 hours storage under room ambient conditions after the device is wiped with dry cloth.

9) High temperature Storage test

Inductance deviation is within $\pm 5.0\%$ after 500 ± 12 hours test under the condition of temperature of $105 \pm 2^\circ\text{C}$ and 1 hours storage under room ambient conditions after which device is tested within the next 1 hour.

10) Low temperature Storage test

Inductance deviation is within $\pm 5.0\%$ after 500 ± 12 hours test under the condition of temperature of $-40 \pm 2^\circ\text{C}$ and 1 hours storage under room ambient conditions after which device is tested within the next 1 hour.

11) Thermal shock test

Specimen is subject to -40°C for 30 minutes hereafter it is subject to 105°C for 30 minutes(Transition time is 1 minute maximum.) This constitutes one cycle. After 1000 cycles, it is then left in room temperature for 1 hour. After which specimen is tested within the next 1 hour and the inductance deviation is within $\pm 5.0\%$

12) Board bent characteristic

Inductance deviation is within $\pm 5.0\%$, after apply pressure in the direction of the arrow at a rate of about 0.5mm/s until bent with reaches 2mm and hold for 30 seconds

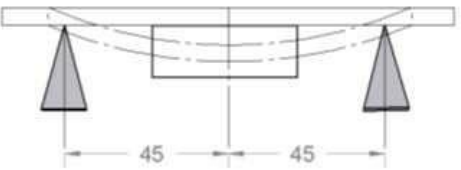

13) Solubility resistance test

Inductance deviation is within $\pm 5.0\%$ after immersing for 1 min in isopropyl alcohol at $25^\circ\text{C} \pm 5^\circ\text{C}$. Then it shall be stabilized under standard atmospheric condition for 1H before measurement. Measurement shall be made within 1 hour

14) Solderability

Electrodes are immersed in flux for 5 seconds. Then dipped in melting solder at $245 \pm 5^\circ\text{C}$, for 3 ± 0.5 seconds, 95% min. of the immersed areas should be covered by new solder.
 ※ Solder item : LCD-D9800C(Sn98%/Cu2% : Flux item : 2HF-7600)

DATA SHEET		PAGE	7 / 10
Part No	ECS-MPI2520R0/R1	Rev.	B

15) Humidity load life test

Inductance deviation is within $\pm 5.0\%$ and no structure and electric defects can be found after 1000 ± 12 hours test under the condition of relative humidity of 80~85% and temperature of $85 \pm 2^\circ\text{C}$ and allowable current loaded and 1 hour storage under room ambient conditions after which device is tested within the next 2 hours

16) High-temperature electrification test

The component is left in a constant temperature chamber of temperature $105 \pm 2^\circ\text{C}$ applying the rated current for 1000 ± 12 hours after the soldering heat resistance test, and then the component is left at room temperature and normal humidity for 2 ± 1 hours. After that, any surface defects shouldn't be found and the rate of inductance against its initial value should be within $\pm 5\%$

17) Low-temperature electrification test

The component is left in a constant temperature chamber of temperature $-40 \pm 3^\circ\text{C}$ applying the rated current for 1000 ± 12 hours after the soldering heat resistance test, and then the component is left at room temperature and normal humidity for 2 ± 1 hours. After that, any surface defects shouldn't be found and the rate of inductance against its initial value should be within $\pm 5\%$

Application Notice / Handling

- 1) Temperature and humidity conditions: less than 40°C and 70% RH.
- 2) Products should be used within 6 months.
- 3) The packaging material should be kept where no chlorine or sulfur exists in the air.
- 4) Do not touch the electrodes (soldering terminals) with fingers as this may lead to deterioration of solderability.
- 5) The use of tweezers or vacuum pick-ups is strongly recommended for individual components.
- 6) Bulk handling should ensure that abrasion and mechanical shock are minimized

Part No

ECS-MPI2520R0/R1

Rev.

B

7. Packaging Standard

1) Packaging data

Component	L(mm)	W(mm)	H(mm)	Wt(g)	Quantity
Part size	2.70	2.20	1.20	0.03	3,000

2) Reel Tape Specification: Units supplied in tape and reel packaging. Meets EIA-481

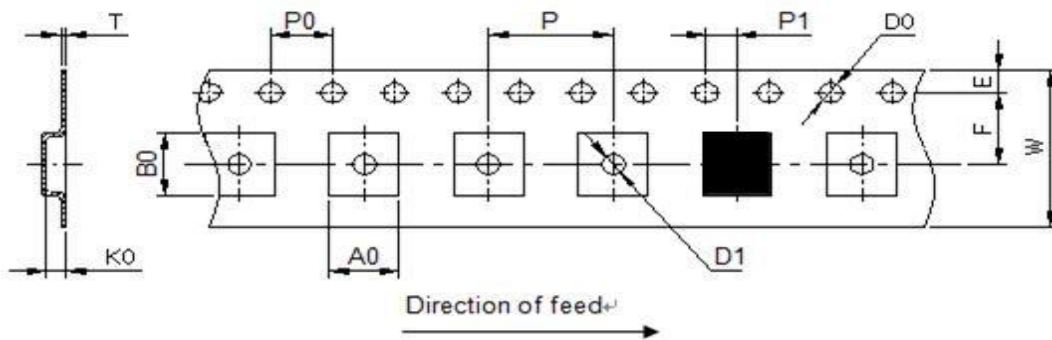

P/N	W	A0	B0	K0	T	P	F	E	D0	D1	P0	P1
ECS-MPI2520	8.0± 0.3	2.3± 0.1	2.8± 0.1	1.3± 0.1	0.3± 0.1	4.0± 0.1	3.9± 0.1	1.75 ±0.1	1.5+ 0.1	1.5± 0.1	4.0± 0.1	2.0± 0.05

3) Taping dimension and tape direction, Leader, Trailer section dimension

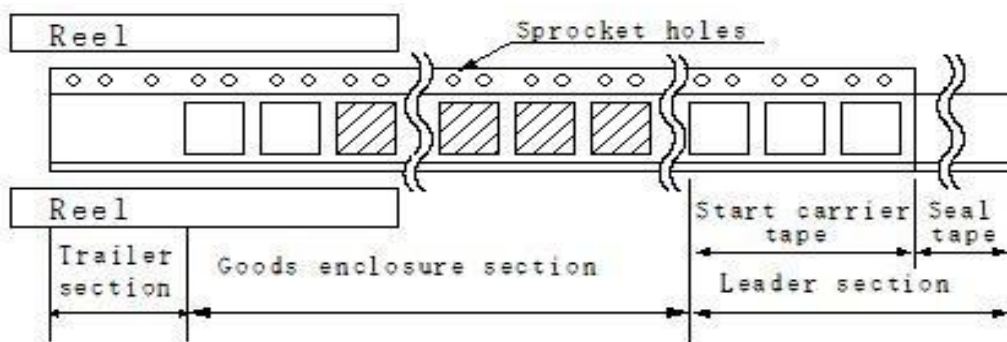

Leader section	Min.400 mm
Carrier tape start size	Min.100 mm
Trailer section size	Min.160 mm

Part No

ECS-MPI2520R0/R1

Rev.

B

4) Taping

The angle between the seal tape during peel off and the direction of unreeling shall be 165°C to 180°C.

The seal tape shall adhere uniformly to the carrier tape along both sides in the direction of unreeling.

The peel force with a peel speed of 300mm/MIN±10mm/MIN shall be 0.1N TO 1.3N.

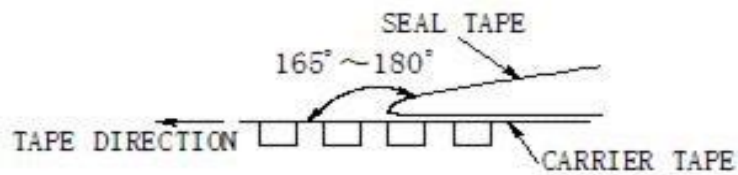

5) Reel Specification

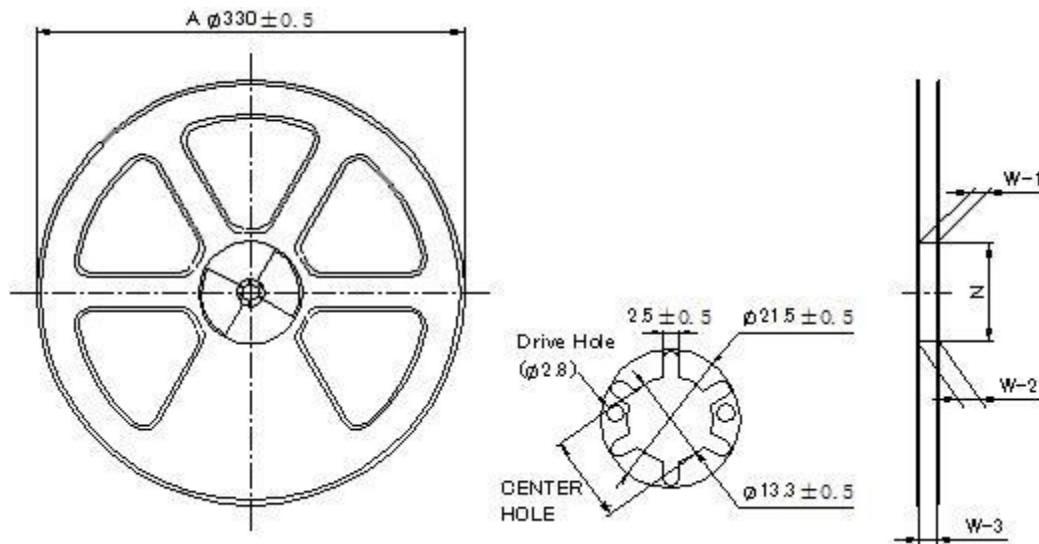

Dimension	A	W-1	W-2	W-3	Center Hole	N
Spec	ø330±0.5	12.4+2/0	16.0±0.5	13.0±0.5	13.3±0.5	ø76±0.5

DATA SHEET		PAGE	10 / 10
Part No	ECS-MPI2520R0/R1	Rev.	B

6) Packing Materials

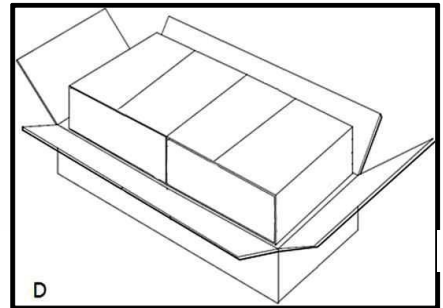
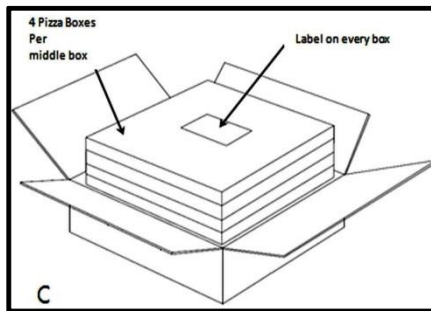
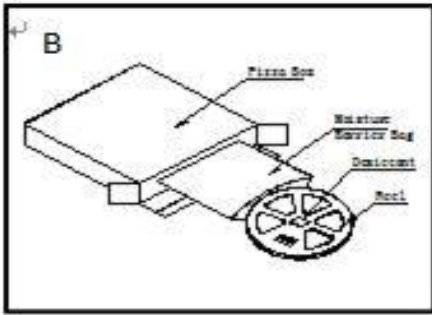

Packing Materials	B. Pizza Box			C. Middle Box			D. Large Box		
Dimension(mm)	L	W	H	L	W	H	L	W	H
	335	335	50	355	355	230	720	370	255

7) Packing Specification

2middle box/Large box, 4Reel/Middle box, 1Reel/Pizza box, 7500pcs/Reel, Total 60000pcs(Large Box)

Reel Dimensions : Ø 330 × 12(mm)

8. Environmental substances requirement

1) RoHs Compliance & Halogen Compliance

Test Items	Unit	Test Method	MDL	Results
Cd	mg/kg	With reference to IEC62321:2008, ICP	0.5	N.D.
Pb	mg/kg	With reference to IEC62321:2008, ICP	5	N.D.
Hg	mg/kg	With reference to IEC62321:2008, ICP	2	N.D.
Cr VI	mg/kg	With reference to IEC62321:2008, UV-VIS	1	N.D.
PBBs	mg/kg	With reference to IEC62321:2008, GC-MS	5	N.D.
PBDEs	mg/kg	With reference to IEC62321:2008, GC-MS	5	N.D.
Br	mg/kg	BS EN 14582:2007, IC	30	N.D.
Cl	mg/kg	BS EN 14582:2007, IC	30	N.D.
F	mg/kg	BS EN 14582:2007, IC	30	N.D.
I	mg/kg	BS EN 14582:2007, IC	50	N.D.

Note

- 1) N.D. = Not detected(< MDL)
- 2) mg/kg = ppm
- 3) MDL = Method Detection Limit
- 4) Test instrument : SGS TEST KOREA

Looking for pricing, stock, or lifecycle information?

Click below to explore more details on WIN SOURCE:

- [View ECS-MPI2520R1-100-R on WIN SOURCE](#)
- [ECS Inc. Information](#)

Optimize Your Supply Chain with WIN SOURCE Solutions

- ✓ Global Sourcing Solution
- ✓ Obsolete Management
- ✓ Cost Control Management
- ✓ Shortage Management
- ✓ Alternative Solution
- ✓ Excess Inventory Management