



**THE DATASHEET OF  
EV20051-N-00A**





The Future of Analog IC Technology®

# EV20051-N-00A

## Low Noise, High PSRR, 1A Linear Regulator EV Board

### DESCRIPTION

The EV20051-N-00A evaluation board demonstrates the performance of MP20051, a low noise and low dropout linear regulator. It operates from 2.5V to 5.5V input voltage and the output voltage can be set externally which ranges from 0.8V to 5V.

The EV20051-N-00A can supply up to 1A of load current, and features current limiting, over temperature protection.

An internal PMOS pass element is used to allow a low 110µA ground current, marking the MP20051 suitable for battery-power devices.

### ELECTRICAL SPECIFICATIONS

Parameter	Symbol	Value	Units
Input Voltage	V <sub>IN</sub>	2.5 – 5.5	V
Output Voltage	V <sub>OUT</sub>	1.1	V
Load Current	I <sub>OUT</sub>	1	A

### FEATURES

- Up to 1A Output Current
- Low 140mV Dropout at 1A
- Adjustable Output from 0.8V to 5V
- 63dB PSRR at 1kHz
- 13µVRMS Low Noise Output
- Very Fast Transient Responses
- Current Limit and Thermal Protection

### APPLICATIONS

- Notebook Computers
- Cordless Telephones
- Cellular Phones
- Modems
- Hand-Held Instruments
- PDA and Palmtop Computers

For MPS green status, please visit MPS website under Quality Assurance. MPS® and "The Future of Analog IC Technology" are Registered Trademarks of Monolithic Power Systems, Inc.

### EV20051DN-00A EVALUATION BOARD

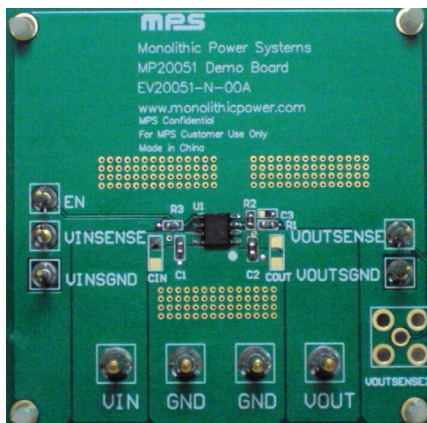

(L x W x H) 2.5" x 2.5" x 0.4"  
(6.35cm x 6.35cm x 1.1cm)

Board Number	MPS IC Number
EV20051-N-00A	MP20051DN

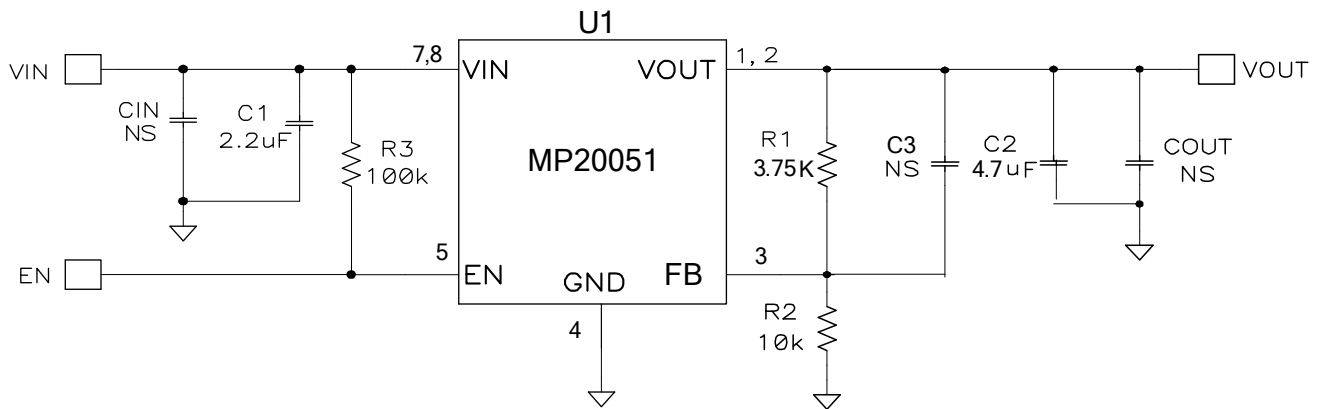
**EVALUATION BOARD SCHEMATIC**

**EV20051DN-00A BILL OF MATERIALS**

Qty	Ref	Value	Description	Package	Manufacturer	Part Number
1	C1	2.2µF	Ceramic Capacitor,X7R,16V	0805	TDK	C2012X7R1C225K
1	C2	4.7µF	Ceramic Capacitor,X5R,10V	0805	TDK	C2012X5R1A475K
0	CIN,COUT, C3	NS				
1	R1	3.75kΩ	Film Res, 1%	0603	Any	
1	R2	10kΩ	Film Res, 1%	0603	Any	
1	R3	100k	Film Res, 5%	0603	Any	
1	U1		LDO Regulator	SOIC8E	MPS	MP20051DN

PRINTED CIRCUIT BOARD LAYOUT

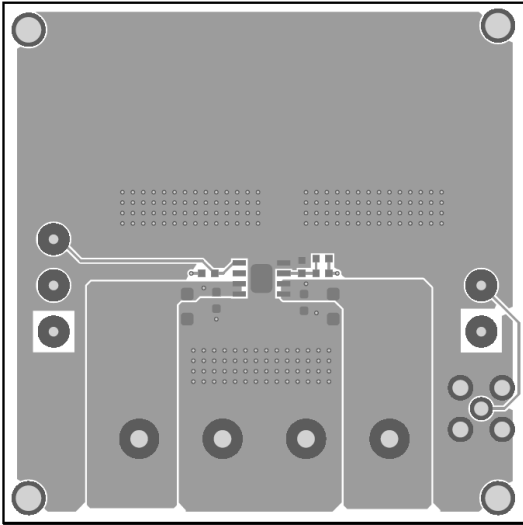

Figure 1—Top Layer

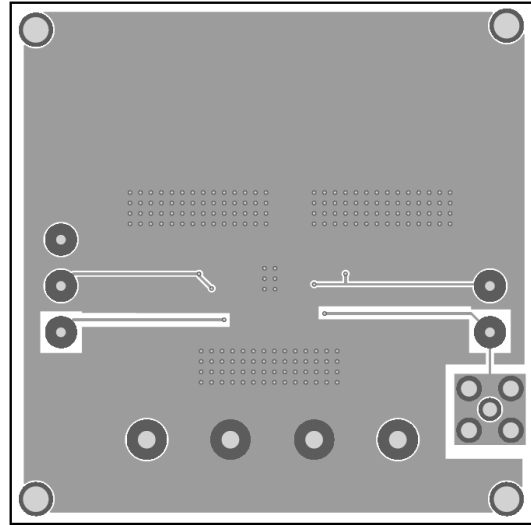

Figure 2—Bottom Layer

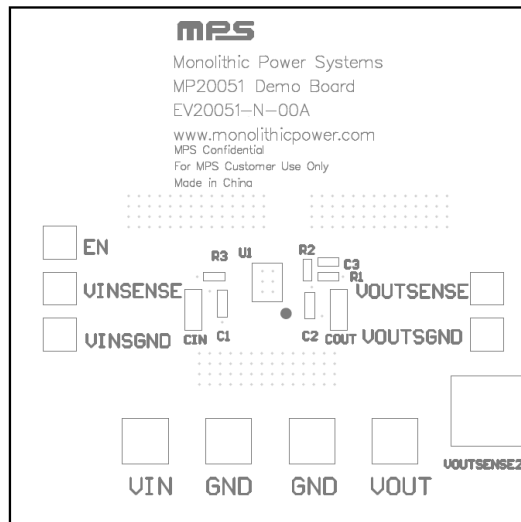

Figure 3—Top Silk Layer

## QUICK START GUIDE (ADJUSTABLE OUTPUT)

The output voltage of this board is set externally which ranges from 0.8V to 5V by operating from +2.5V to +5.5V input as the figure 4. The default output voltage of this board is set to 1.1V.

The board layout accommodates most commonly used resistors and capacitors.

1. Attach the positive and negative ends of the load to the V<sub>OUT</sub> and GND pins, respectively.
2. Attach the Input Voltage ( $2.5V \leq V_{IN} \leq 5.5V$ ) and Input Ground to the VIN and GND pins respectively.
3. To enable the MP20051, apply a voltage  $1.5V \leq V_{EN} \leq 5.5V$ , to the EN pin. To disable the MP20051, apply a voltage,  $V_{EN} < 0.4V$ , to the EN pin. The EN pin can be connected to V<sub>IN</sub> with a 100kΩ resistor for automatic startup.
4. The Output Voltage V<sub>OUT</sub> can be changed by varying R1. Calculate the new value by formula:

$$R1 = R2 \left( \frac{V_{OUT}}{V_{FB}} - 1 \right)$$

Where  $V_{FB} = 0.8V$  and  $R2 = 10k\Omega$ .

Example:

For  $V_{OUT} = 1.1V$ :

$$R1 = 10k\Omega \left( \frac{1.1}{0.8} - 1 \right) = 3.75k\Omega$$

Therefore, use a 3.75kΩ standard 1% value.

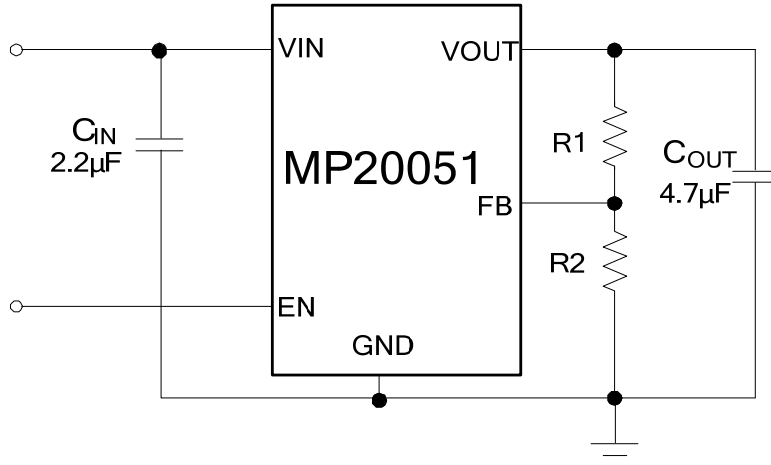

Figure 4



## Revision History

Revision #	Revision Date	Description	Pages Updated
1.0	8/3/2011	Initial Release	-
1.1	7/31/2020	Rename version	all

**NOTICE:** The information in this document is subject to change without notice. Users should warrant and guarantee that third party Intellectual Property rights are not infringed upon when integrating MPS products into any application. MPS will not assume any legal responsibility for any said applications.

## Looking for pricing, stock, or lifecycle information?

Click below to explore more details on WIN SOURCE:

-  [View EV20051-N-00A on WIN SOURCE](#)
-  [Monolithic Power Systems Inc. Information](#)

## Optimize Your Supply Chain with WIN SOURCE Solutions

-  Global Sourcing Solution
-  Obsolete Management
-  Cost Control Management
-  Shortage Management
-  Alternative Solution
-  Excess Inventory Management