



**THE DATASHEET OF  
MIMX8MM6DVTLZAA**



MIMX8MM6DVTLZAA MIMX8MM5DVTLZAA  
MIMX8MM5DVTLZCA MIMX8MM5DVTLZDA  
MIMX8MM4DVTLZAA MIMX8MM3DVTLZAA  
MIMX8MM2DVTLZAA MIMX8MM1DVTLZAA

# i.MX 8M Mini Applications Processor Datasheet for Consumer Products

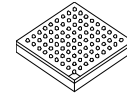

**Package Information**  
Plastic Package  
FCBGA 14 x 14 mm, 0.5 mm pitch

<b>Ordering Information</b>
See <a href="#">Table 2 on page 6</a>

## 1 i.MX 8M Mini introduction

The i.MX 8M Mini applications processor represents NXP’s latest video and audio experience combining state-of-the-art media-specific features with high-performance processing while optimized for lowest power consumption.

The i.MX 8M Mini family of processors features advanced implementation of a quad Arm® Cortex®-A53 core, which operates at speeds of up to 1.8 GHz. A general purpose Cortex®-M4 400 MHz core processor is for low-power processing. The DRAM controller supports 32-bit/16-bit LPDDR4, DDR4, and DDR3L memory. A wide range of audio interfaces are available, including I2S, AC97, TDM, and S/PDIF. There are a number of other interfaces for connecting peripherals, such as USB, PCIe, and Ethernet.

1. i.MX 8M Mini introduction	1
1.1. Block diagram	5
1.2. Ordering information	6
2. Modules list	8
2.1. Recommended connections for unused input/output	12
3. Electrical characteristics	14
3.1. Chip-level conditions	14
3.2. Power supplies requirements and restrictions	23
3.3. PLL electrical characteristics	27
3.4. On-chip oscillators	28
3.6. I/O AC parameters	31
3.5. General purpose I/O (GPIO) DC parameters	29
3.7. Output buffer impedance parameters	32
3.8. System modules timing	34
3.9. External peripheral interface parameters	36
4. Boot mode configuration	71
4.1. Boot mode configuration pins	71
4.2. Boot device interface allocation	72
5. Package information and contact assignments	73
5.1. 14 x 14 mm package information	73
5.2. DDR pin function list	90
6. Revision history	94



Table 1. Features

Subsystem	Features
Arm Cortex-A53 MPCore platform	Quad symmetric Cortex-A53 processors <ul style="list-style-type: none"> <li>• 32 KB L1 Instruction Cache</li> <li>• 32 KB L1 Data Cache</li> <li>• Media Processing Engine (MPE) with NEON technology supporting the Advanced Single Instruction Multiple Data architecture:</li> <li>• Floating Point Unit (FPU) with support of the VFPv4-D16 architecture</li> </ul>
	Support of 64-bit Armv8-A architecture
	512 KB unified L2 cache
Arm Cortex-M4 core platform	Low power microcontroller available for customer application: <ul style="list-style-type: none"> <li>• low power standby mode</li> <li>• IoT features including Weave</li> <li>• Manage IR or Wireless Remote</li> </ul>
	Cortex M4 CPU: <ul style="list-style-type: none"> <li>• 16 KB L1 Instruction Cache</li> <li>• 16 KB L1 Data Cache</li> <li>• 256 KB tightly coupled memory (TCM)</li> </ul>
Connectivity	One PCI Express (PCIe) <ul style="list-style-type: none"> <li>• Single lane supporting PCIe Gen2</li> <li>• Dual mode operation to function as root complex or endpoint</li> <li>• Integrated PHY interface</li> <li>• Support L1 low power sub-state</li> </ul>
	Two USB 2.0 OTG controllers with integrated PHY interfaces: <ul style="list-style-type: none"> <li>• Spread spectrum clock support</li> </ul>
	Three Ultra Secure Digital Host Controller (uSDHC) interfaces: <ul style="list-style-type: none"> <li>• MMC 5.1 compliance with HS400 DDR signaling to support up to 400 MB/sec</li> <li>• SD/SDIO 3.0 compliance with 200 MHz SDR signaling to support up to 100 MB/sec</li> <li>• Support for SDXC (extended capacity)</li> </ul>
	One Gigabit Ethernet controller with support for Energy Efficient Ethernet (EEE), Ethernet AVB, and IEEE 1588
	Four Universal Asynchronous Receiver/Transmitter (UART) modules
	Four I <sup>2</sup> C modules
	Three ECSPi modules
On-chip memory	Boot ROM (256 KB)
	On-chip RAM (256 KB + 32 KB)
GPIO and pin multiplexing	General-purpose input/output (GPIO) modules with interrupt capability
	Input/output multiplexing controller (IOMUXC) to provide centralized pad control
Power management	Temperature sensor with programmable trip points
	Flexible power domain partitioning with internal power switches to support efficient power management

Table 1. Features (continued)

Subsystem	Features
External memory interface	32/16-bit DRAM interfaces: <ul style="list-style-type: none"> <li>• LPDDR4 (up to 1.5 GHz)</li> <li>• DDR4-2400</li> <li>• DDR3L-1600</li> </ul>
	8-bit NAND-Flash, including support for Raw MLC/SLC devices, BCH ECC up to 62-bit, and ONFi3.2 compliance (clock rates up to 100 MHz and data rates up to 200 MB/sec)
	eMMC 5.1 Flash (2 interfaces, uSDHC1 and uSDHC3)
	SPI NOR Flash (3 interfaces)
	FlexSPI with support for XIP (for ME in low-power mode) and parallel read mode of two identical FLASH devices
Multimedia	Video Processing Unit: <ul style="list-style-type: none"> <li>• 1080p60 VP9 Profile 0, 2 (10-bit)</li> <li>• 1080p60 HEVC/H.265 Decoder</li> <li>• 1080p60 AVC/H.264 Baseline, Main, High decoder</li> <li>• 1080p60 VP8</li> <li>• 1080p60 AVC/H.264 Encoder</li> <li>• 1080p60 VP8</li> <li>• TrustZone support</li> </ul>
	Graphic Processing Unit: <ul style="list-style-type: none"> <li>• GCNanoUltra for 3D acceleration</li> <li>• GC320 for 2D acceleration</li> </ul>
	LCDIF Display Controller: <ul style="list-style-type: none"> <li>• Support up to 2 layers of overlay</li> <li>• Support up to 1080p60 display through MIPI DSI</li> </ul>
	MIPI Interface: <ul style="list-style-type: none"> <li>• 4-lane MIPI CSI interface</li> <li>• 4-lane MIPI DSI interface</li> </ul>
	Audio: <ul style="list-style-type: none"> <li>• S/PDIF input and output, including a new Raw Capture input mode</li> <li>• Five synchronous audio interface (SAI) modules supporting I2S, AC97, TDM, codec/DSP, and DSD interfaces, including one SAI with 8 Tx and 8 Rx lanes, one SAI with 4 Tx and 4 Rx lanes, two SAI with 2 Tx and 2 Rx lanes, and one SAI with 1 Tx and 1Rx lane. Support over 20 channels of audio subject to I/O limitations.</li> <li>• 8-Channel Pulse Density Modulation (PDM) input</li> </ul>
System debug	Arm CoreSight debug and trace architecture
	Trace Port Interface Unit (TPIU) to support off-chip real-time trace
	Embedded Trace FIFO (ETF) with 4 KB internal storage to provide trace buffering
	Unified trace capability for Quad Cortex-A53 and Cortex-M4 CPUs
	Cross Triggering Interface (CTI)
	Support for 5-pin (JTAG) debug interface

**Table 1. Features (continued)**

Subsystem	Features
Security	Resource Domain Controller (RDC) supports four domains and up to eight regions of DDR
	Arm TrustZone (TZ) architecture: <ul style="list-style-type: none"> <li>• Support Arm Cortex-A53 MPCore TrustZone</li> </ul>
	On-chip RAM (OCRAM) secure region protection using OCRAM controller
	High Assurance Boot (HAB)
	Cryptographic acceleration and assurance (CAAM) module and Assurance Module: <ul style="list-style-type: none"> <li>• Support Widevine and PlayReady content protection</li> <li>• Public Key Cryptography (PKHA) with RSA and Elliptic Curve (ECC) algorithms</li> <li>• Real-time integrity checker (RTIC)</li> <li>• DRM support for RSA, AES, 3DES, DES</li> <li>• Side channel attack resistance</li> <li>• True random number generation (RNG)</li> <li>• Manufacturing protection support</li> </ul>
	Secure non-volatile storage (SNVS): <ul style="list-style-type: none"> <li>• Secure real-time clock (RTC)</li> </ul>
	Secure JTAG controller (SJC)

**NOTE**

The actual feature set depends on the part numbers as described in [Table 2](#). Functions such as display and camera interfaces, and connectivity interfaces, may not be enabled for specific part numbers.

## 1.1 Block diagram

Figure 1 shows the functional modules in the i.MX 8M Mini applications processor system.

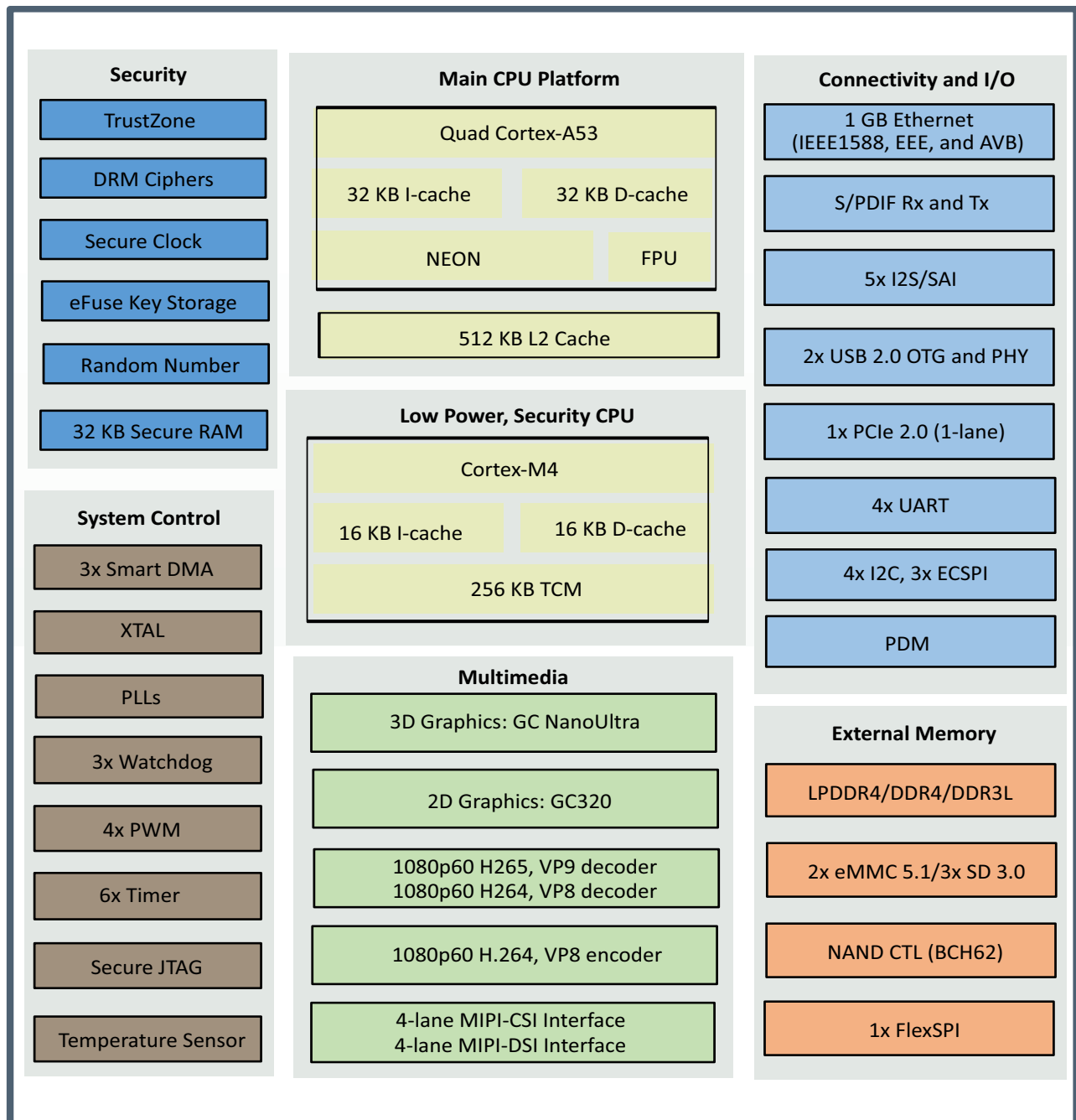

Figure 1. i.MX 8M Mini system block diagram

## 1.2 Ordering information

Table 2 shows examples of orderable sample part numbers covered by this data sheet. This table does not include all possible orderable part numbers. If your desired part number is not listed in the table, or you have questions about available parts, contact your NXP representative.

**Table 2. Orderable part numbers**

Family	Part number	Part differentiator	Cortex-A53 CPU speed grade	Qualification tier	Temperature T <sub>j</sub> (°C)	Package
i.MX 8M Mini Quad	MIMX8MM6DVTLZAA	4x A53, M4, GPU, VPU	1.8 GHz	Consumer	0 to +95	14 x 14 mm, 0.5 mm pitch
i.MX 8M Mini QuadLite	MIMX8MM5DVTLZAA	4x A53, M4, GPU	1.8 GHz	Consumer	0 to +95	14 x 14 mm, 0.5 mm pitch
i.MX 8M Mini QuadLite	MIMX8MM5DVTLZCA	4x A53, M4, GPU, Immersiv3D with Dolby ATMOS support <sup>1</sup>	1.8 GHz	Consumer	0 to +95	14 x 14 mm, 0.5 mm pitch
i.MX 8M Mini QuadLite	MIMX8MM5DVTLZDA	4x A53, M4, GPU, Immersiv3D with Dolby ATMOS and DTS support <sup>1</sup>	1.8 GHz	Consumer	0 to +95	14 x 14 mm, 0.5 mm pitch
i.MX 8M Mini Dual	MIMX8MM4DVTLZAA	2x A53, M4, GPU, VPU	1.8 GHz	Consumer	0 to +95	14 x 14 mm, 0.5 mm pitch
i.MX 8M Mini DualLite	MIMX8MM3DVTLZAA	2x A53, M4, GPU	1.8 GHz	Consumer	0 to +95	14 x 14 mm, 0.5 mm pitch
i.MX 8M Mini Solo	MIMX8MM2DVTLZAA	1x A53, M4, GPU, VPU	1.8 GHz	Consumer	0 to +95	14 x 14 mm, 0.5 mm pitch
i.MX 8M Mini SoloLite	MIMX8MM1DVTLZAA	1x A53, M4, GPU	1.8 GHz	Consumer	0 to +95	14 x 14 mm, 0.5 mm pitch

<sup>1</sup> Supply of this Implementation of Dolby technology does not convey a license nor imply a right under any patent, or any other industrial or intellectual property right of Dolby Laboratories, to use this Implementation in any finished end-user or ready-to-use final product. It is hereby notified that a license for such use is required from Dolby Laboratories.

Figure 2 describes the part number nomenclature so that the users can identify the characteristics of the specific part number.

Contact an NXP representative for additional details.

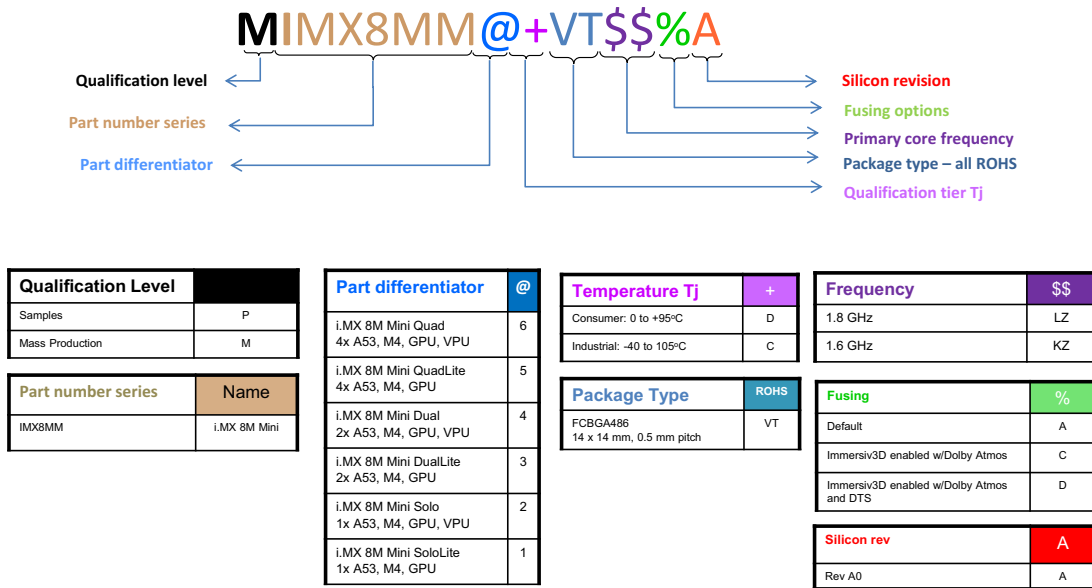

Figure 2. Part number nomenclature—i.MX 8M Mini family of processors

## 2 Modules list

The i.MX 8M Mini family of processors contains a variety of digital and analog modules. [Table 3](#) describes these modules in alphabetical order.

**Table 3. i.MX 8M Mini modules list**

Block mnemonic	Block name	Brief description
32k Oscillator	Clock system	32 KHz oscillator is used as the clock source for RTC and internal low speed clock. It can be supplied by external 32.768 KHz oscillator.
APBH-DMA	NAND Flash and BCH ECC DMA Controller	DMA controller used for GPMI2 operation.
Arm	Arm Platform	The Arm Core Platform includes a quad Cortex-A53 core and a Cortex-M4 core. The Cortex-A53 core includes associated sub-blocks, such as the Level 2 Cache Controller, Snoop Control Unit (SCU), General Interrupt Controller (GIC), private timers, watchdog, and CoreSight debug modules. The Cortex-M4 core is used as a customer microcontroller.
BCH	Binary-BCH ECC Processor	The BCH module provides up to 62-bit ECC encryption/decryption for NAND Flash controller (GPMI)
CAAM	Cryptographic accelerator and assurance module	CAAM is a cryptographic accelerator and assurance module. CAAM implements several encryption and hashing functions, a run-time integrity checker, entropy source generator, and a Pseudo Random Number Generator (PRNG). The PRNG is certifiable by the Cryptographic Algorithm Validation Program (CAVP) of the National Institute of Standards and Technology (NIST). CAAM also implements a Secure Memory mechanism. In i.MX 8M Mini processors, the secure memory provided is 32 KB.
CCM GPC SRC	Clock Control Module, General Power Controller, System Reset Controller	These modules are responsible for clock and reset distribution in the system, and also for the system power management.
CSU	Central Security Unit	The Central Security Unit (CSU) is responsible for setting comprehensive security policy within the i.MX 8M Mini platform.
CTI-0 CTI-1 CTI-2 CTI-3 CTI-4	Cross Trigger Interface	Cross Trigger Interface (CTI) allows cross-triggering based on inputs from masters attached to CTIs. The CTI module is internal to the Cortex-A53 core platform.
DAP	Debug Access Port	The DAP provides real-time access for the debugger without halting the core to access: <ul style="list-style-type: none"> <li>• System memory and peripheral registers</li> <li>• All debug configuration registers</li> </ul> The DAP also provides debugger access to JTAG scan chains.
DDRC	Double Data Rate Controller	The DDR Controller has the following features: <ul style="list-style-type: none"> <li>• Supports 32/16-bit LPDDR4 (up to 1.5 GHz), DDR4-2400, and DDR3L-1600</li> <li>• Supports up to 8 Gbyte DDR memory space</li> </ul>
eCSPI1 eCSPI2 eCSPI3	Configurable SPI	Full-duplex enhanced Synchronous Serial Interface, with data rate up to 52 Mbit/s. Configurable to support Master/Slave modes, only one chip select is supported.

Table 3. i.MX 8M Mini modules list (continued)

Block mnemonic	Block name	Brief description
ENET1	Ethernet Controller	The Ethernet Media Access Controller (MAC) is designed to support 10/100/1000 Mbps Ethernet/IEEE 802.3 networks. An external transceiver interface and transceiver function are required to complete the interface to the media. The module has dedicated hardware to support the IEEE 1588 standard. See the ENET chapter of the <i>i.MX 8M Mini Applications Processor Reference Manual (IMX8MMRM)</i> for details.
FlexSPI	FlexSPI	The FlexSPI module acts as an interface to external serial flash devices. This module contains the following features: <ul style="list-style-type: none"> <li>• Flexible sequence engine to support various flash vendor devices</li> <li>• Single pad/Dual pad/Quad pad mode of operation</li> <li>• Single Data Rate/Double Data Rate mode of operation</li> <li>• Parallel Flash mode</li> <li>• DMA support</li> <li>• Memory mapped read access to connected flash devices</li> <li>• Multi master access with priority and flexible and configurable buffer for each master</li> </ul>
GIC	Generic Interrupt Controller	The GIC handles all interrupts from the various subsystems and is ready for virtualization.
GPIO1 GPIO2 GPIO3 GPIO4 GPIO5	General Purpose I/O Modules	Used for general purpose input/output to external ICs. Each GPIO module supports up to 32 bits of I/O.
GPMI	General Purpose Memory Interface	The GPMI module supports up to 8x NAND devices and 62-bit ECC encryption/decryption for NAND Flash Controller (GPMI2). GPMI supports separate DMA channels for each NAND device.
GPT1 GPT2 GPT3 GPT4 GPT5 GPT6	General Purpose Timer	Each GPT is a 32-bit “free-running” or “set-and-forget” mode timer with programmable prescaler and compare and capture register. A timer counter value can be captured using an external event and can be configured to trigger a capture event on either the leading or trailing edges of an input pulse. When the timer is configured to operate in “set-and-forget” mode, it is capable of providing precise interrupts at regular intervals with minimal processor intervention. The counter has output compare logic to provide the status and interrupt at comparison. This timer can be configured to run either on an external clock or on an internal clock.
GPU3D	Graphics Processing Unit-3D	The GPU3D provides hardware acceleration for 3D graphics algorithms with sufficient processor power to run desktop quality interactive graphics applications on displays.
I2C1 I2C2 I2C3 I2C4	I <sup>2</sup> C Interface	I <sup>2</sup> C provides serial interface for external devices. Data rates of up to 320 kbps are supported.
IOMUXC	IOMUX Control	This module enables flexible I/O multiplexing. Each IO pad has a default as well as several alternate functions. The alternate functions are software configurable.

**Table 3. i.MX 8M Mini modules list (continued)**

Block mnemonic	Block name	Brief description
MIPI CSI2 (four-lane)	MIPI Camera Serial Interface	This module provides one four-lane MIPI camera serial interfaces, which operates up to a maximum bit rate of 1.5 Gbps.
MIPI DSI (four-lane)	MIPI Display Serial Interface	This module provides a four-lane MIPI display serial interface operating up to a maximum bit rate of 1.5 Gbps.
OCOTP_CTRL	OTP Controller	The On-Chip OTP controller (OCOTP_CTRL) provides an interface for reading, programming, and/or overriding identification and control information stored in on-chip fuse elements. The module supports electrically programmable poly fuses (eFUSES). The OCOTP_CTRL also provides a set of volatile software-accessible signals that can be used for software control of hardware elements, not requiring non volatility. The OCOTP_CTRL provides the primary user-visible mechanism for interfacing with on-chip fuse elements. Among the uses for the fuses are unique chip identifiers, mask revision numbers, cryptographic keys, JTAG secure mode, boot characteristics, and various control signals requiring permanent non volatility.
OCRAM	On-Chip Memory controller	The On-Chip Memory controller (OCRAM) module is designed as an interface between the system's AXI bus and the internal (on-chip) SRAM memory module. In i.MX 8M Mini processors, the OCRAM is used for controlling the 256 KB multimedia RAM through a 64-bit AXI bus.
PCIe1	PCI Express 2.0	The PCIe IP provides PCI Express Gen 2.0 functionality.
PDM	Pulse Density Modulation	The PDM supports up to 8-channels (4 lanes).
PMU	Power Management Unit	Integrated power management unit. Used to provide power to various SoC domains.
PWM1 PWM2 PWM3 PWM4	Pulse Width Modulation	The pulse-width modulator (PWM) has a 16-bit counter and is optimized to generate sound from stored sample audio images. It can also generate tones. It uses 16-bit resolution and a 4x16 data FIFO to generate sound.
SAI1 SAI2 SAI3 SAI5 SAI6	Synchronous Audio Interface	The SAI module provides a synchronous audio interface (SAI) that supports full duplex serial interfaces with frame synchronization, such as I2S, AC97, TDM, and codec/DSP interfaces.

Table 3. i.MX 8M Mini modules list (continued)

Block mnemonic	Block name	Brief description
SDMA	Smart Direct Memory Access	<p>The SDMA is a multichannel flexible DMA engine. It helps in maximizing system performance by offloading the various cores in dynamic data routing. It has the following features:</p> <ul style="list-style-type: none"> <li>• Powered by a 16-bit Instruction-Set micro-RISC engine</li> <li>• Multi channel DMA supporting up to 32 time-division multiplexed DMA channels</li> <li>• 48 events with total flexibility to trigger any combination of channels</li> <li>• Memory accesses including linear, FIFO, and 2D addressing</li> <li>• Shared peripherals between Arm and SDMA</li> <li>• Very fast Context-Switching with 2-level priority based preemptive multi tasking</li> <li>• DMA units with auto-flush and prefetch capability</li> <li>• Flexible address management for DMA transfers (increment, decrement, and no address changes on source and destination address)</li> <li>• DMA ports can handle unidirectional and bidirectional flows (Copy mode)</li> <li>• Up to 8-word buffer for configurable burst transfers for EMIv2.5</li> <li>• Support of byte-swapping and CRC calculations</li> <li>• Library of Scripts and API is available</li> </ul>
SJC	Secure JTAG Controller	<p>The SJC provides JTAG interface (designed to be compatible with JTAG TAP standards) to internal logic. The i.MX 8M Mini family of processors uses JTAG port for production, testing, and system debugging. Additionally, the SJC provides BSR (Boundary Scan Register) standard support, designed to be compatible with IEEE 1149. 1.</p> <p>The JTAG port must be accessible during platform initial laboratory bring-up, for manufacturing tests and troubleshooting, as well as for software debugging by authorized entities. The i.MX 8M Mini SJC incorporates three security modes for protecting against unauthorized accesses. Modes are selected through eFUSE configuration.</p>
SNVS	Secure Non-Volatile Storage	Secure Non-Volatile Storage, including Secure Real Time Clock, Security State Machine, Master Key Control, and Violation/Tamper Detection and reporting.
SPDIF1	Sony Philips Digital Interconnect Format	A standard audio file transfer format, developed jointly by the Sony and Phillips corporations. It supports Transmitter and Receiver functionality.
TEMPSENSOR	Temperature Sensor	Temperature sensor
TZASC	Trust-Zone Address Space Controller	The TZASC (TZC-380 by Arm) provides security address region control functions required for intended application. It is used on the path to the DRAM controller.

**Table 3. i.MX 8M Mini modules list (continued)**

Block mnemonic	Block name	Brief description
UART1 UART2 UART3 UART4	UART Interface	Each of the UARTv2 modules supports the following serial data transmit/receive protocols and configurations: <ul style="list-style-type: none"> <li>• 7- or 8-bit data words, 1 or 2 stop bits, programmable parity (even, odd, or none)</li> <li>• Programmable baud rates up to 4 Mbps. This is a higher max baud rate relative to the 1.875 MHz, which is stated by the TIA/EIA-232-F standard.</li> <li>• 32-byte FIFO on Tx and 32 half-word FIFO on Rx supporting auto-baud</li> </ul>
uSDHC1 uSDHC2 uSDHC3	SD/MMC and SDXC Enhanced Multi-Media Card / Secure Digital Host Controller	i.MX 8M Mini SoC characteristics: All the MMC/SD/SDIO controller IPs are based on the uSDHC IP. They are designed to support: <ul style="list-style-type: none"> <li>• SD/SDIO standard, up to version 3.0.</li> <li>• MMC standard, up to version 5.1.</li> <li>• 1.8 V and 3.3 V operation, but do not support 1.2 V operation.</li> <li>• 1-bit/4-bit SD and SDIO modes, 1-bit/4-bit/8-bit MMC mode.</li> </ul> Two uSDHC controllers (uSDHC1 and uSDHC3) can support up to an 8-bit interface, the other controller (uSDHC2) can only support up to a 4-bit interface.
USB1 USB2	2x USB 2.0 controllers and PHYs	Two USB controllers and PHYs that support USB 2.0. Each USB instance contains: <ul style="list-style-type: none"> <li>• USB 2.0 core, which can operate in 2.0 mode</li> </ul>
VPU	Video Processing Unit	A high performing video processing unit (VPU), which covers many SD-level and HD-level video decoders. See the <i>i.MX 8M Mini Applications Processor Reference Manual (IMX8MMRM)</i> for a complete list of the VPU's decoding and encoding capabilities.
WDOG1 WDOG2 WDOG3	Watchdog	The watchdog (WDOG) timer supports two comparison points during each counting period. Each of the comparison points is configurable to evoke an interrupt to the Arm core, and a second point evokes an external event on the WDOG line.
XTALOSC	Crystal Oscillator interface	The XTALOSC module enables connectivity to an external crystal oscillator device. In a typical application use case, it is used for a 24 MHz oscillator.

## 2.1 Recommended connections for unused input/output

If a function of the i.MX 8M Mini is not in use, the I/Os and power rails of that function can be terminated to reduce overall board power.

Table 4 shows the recommended connections for unused power supply rails.

**Table 4. Recommended connections for unused power supply rails**

Function	Ball Name	Recommendations if Unused
MIP-CSI and MIPI-DSI	VDD_MIPI_0P9, VDD_MIPI_1P2, VDD_MIPI_1P8	Leave unconnected
PCIe	VDD_PCI_0P8, VDD_PCI_1P8	Leave unconnected

**Table 4. Recommended connections for unused power supply rails (continued)**

Function	Ball Name	Recommendations if Unused
USB1 and USB2	VDD_USB_0P8, VDD_USB_1P8, VDD_USB_3P3	Leave unconnected
VPU	VDD_VPU	Leave unconnected
GPU	VDD_GPU	Leave unconnected
Digital I/O supplies	NVCC_CLK, NVCC_ECSPi, NVCC_ENET, NVCC_GPIO1, NVCC_I2C, NVCC_JTAG, NVCC_NAND, NVCC_SAI1, NVCC_SAI2, NVCC_SAI3, NVCC_SAI5, NVCC_SD1, NVCC_SD2, NVCC_UART, NVCC_SNVS_1P8, PVCC0_1P8, PVCC1_1P8, PVCC2_1P8	All digital I/O supplies listed in this table must be powered under normal conditions whether the associated I/O pins are in use or not, and associated I/O pins need to enable pull in pad control register to limit any floating gate current.

Table 5 shows recommended connections for unused signal contacts/interfaces.

**Table 5. Recommended connections for unused signal contacts/interfaces**

Function	Ball Name	Recommendations if Unused
MIPI-CSI	MIPI_CSI_CLK_P, MIPI_CSI_CLK_N, MIPI_CSI_Dx_P, MIPI_CSI_Dx_N	Tie all signals to ground
MIPI-DSI	MIPI_VREG_CAP, MIPI_DSI_CLK_P, MIPI_DSI_CLK_N, MIPI_DSI_Dx_P, MIPI_DSI_Dx_N	Leave unconnected
PCIe	PCIE_CLK_P, PCIe_CLK_N, PCIe_TXN_P, PCIe_TXN_N, PCIe_RXN_P, PCIe_RXN_N, PCIe_RESREF	Leave unconnected
USB1	USB1_VBUS, USB1_DN, USB1_DP, USB1_ID, USB1_TXRTUNE	Leave unconnected
USB2	USB2_VBUS, USB2_DN, USB2_DP, USB2_ID, USB2_TXRTUNE	Leave unconnected

## 3 Electrical characteristics

This section provides the device and module-level electrical characteristics for the i.MX 8M Mini family of processors.

### 3.1 Chip-level conditions

This section provides the device-level electrical characteristics for the IC. See [Table 6](#) for a quick reference to the individual tables and sections.

**Table 6. i.MX 8M Mini chip-level conditions**

For these characteristics, ...	Topic appears ...
<a href="#">Absolute maximum ratings</a>	<a href="#">on page 14</a>
<a href="#">FCBGA package thermal resistance</a>	<a href="#">on page 16</a>
<a href="#">Operating ranges</a>	<a href="#">on page 17</a>
<a href="#">External clock sources</a>	<a href="#">on page 19</a>
<a href="#">Maximum supply currents</a>	<a href="#">on page 20</a>

#### 3.1.1 Absolute maximum ratings

#### CAUTION

Stresses beyond those listed under [Table 7](#) may affect reliability or cause permanent damage to the device. These are stress ratings only. Functional operation of the device at these or any other conditions beyond those indicated in the operating ranges or parameters tables is not implied.

**Table 7. Absolute maximum ratings**

Parameter description	Symbol	Min	Max	Unit	Notes
Core supply voltages	VDD_ARM VDD_SOC	-0.3	1.15	V	—
Power supply for GPU	VDD_GPU	-0.3	1.15	V	—
Power supply for VPU	VDD_VPU	-0.3	1.15	V	—
DDR PHY supply voltage	VDD_DRAM	-0.3	1.15	V	—
DDR I/O supply voltage	NVCC_DRAM	-0.3	1.575	V	—
DRAM PLL supply voltage	VDD_DRAM_PLL_0P8	-0.3	1.15	V	—
	VDD_DRAM_PLL_1P8	-0.3	2.15	V	—
SNVS IO supply voltage	NVCC_SNVS_1V8	-0.3	2.15	V	—
VDD_SNVS supply voltage	VDD_SNVS_0V8	-0.3	0.95	V	—

Table 7. Absolute maximum ratings (continued)

Parameter description	Symbol	Min	Max	Unit	Notes
GPIO supply voltage	NVCC_JTAG, NVCCGPIO1, NVCC_ENET, NVCC_SD1, NVCC_SD2, NVCC_NAND, NVCC_SA1, NVCC_SAI2, NVCC_SAI3, NVCC_SAI5, NVCC_ECSPi, NVCC_I2C, NVCC_UART, NVCC_CLK	-0.3	3.8	V	—
GPIO pre-driver supply voltage	PVCC0_1P8, PVCC1_1P8, PVCC2_1P8	-0.3	2.15	V	—
Isolated core supply voltage	VDD_ANA_0P8	-0.3	1.15	V	—
Analog core supply voltage	VDD_ANA0_1P8	-0.3	2.15	V	—
	VDD_ANA1_1P8	-0.3	2.15	V	—
Arm PLL supply voltage	VDD_ARM_PLL_0P8	-0.3	0.95	V	—
	VDD_ARM_PLL_1P8	-0.3	2.15	V	—
MIPI PHY supply voltage	VDD_MIPI_0P9	-0.3	1.05	V	—
	VDD_MIPI_1P2	-0.3	1.45	V	—
	VDD_MIPI_1P8	-0.3	2.15	V	—
PCIe PHY supply voltage	VDD_PCIE_0P8	-0.3	0.95	V	—
	VDD_PCIE_1P8	-0.3	2.15	V	—
USB PHY supply voltage	VDD_USB_0P8	-0.3	0.95	V	—
	VDD_USB_1P8	-0.3	2.15	V	—
	VDD_USB_3P3	-0.3	3.95	V	—
USB_VBUS input detected	USB1_VBUS, USB2_VBUS	-0.3	3.95	V	—
XTAL supply voltage	VDD_24M_XTAL_1P8	-0.3	2.15	V	—
Storage temperature range	T <sub>STORAGE</sub>	-40	150	°C	—

Table 8. Electrostatic discharge and latch up ratings

Parameter description		Rating	Reference	Comment
Electrostatic Discharge (ESD)	Human Body Model (HBM)	±1000 V	JS-001-2017	—
	Charged Device Model (CDM)	±250 V	JS-002-2018	—
Latch UP (LU)	Immunity level: <ul style="list-style-type: none"> <li>• Class I @ 25 °C ambient temperature</li> <li>• Class II @ 105 °C ambient temperature</li> </ul>	A A	JESD78E	—

## 3.1.2 Thermal resistance

### 3.1.2.1 FCBGA package thermal resistance

Table 9 displays the FCBGA package thermal resistance data.

Table 9. Thermal resistance data

Rating	Test conditions	Symbol	Value	Unit	Notes
Junction to Ambient Natural Convection	Single layer board (1s)	$R_{\theta JA}$	30	°C/W	1, 2
Junction to Ambient Natural Convection	Four layer board (2s2p)	$R_{\theta JA}$	22.9	°C/W	1, 2, 3
Junction to Ambient (@200 ft/min)	Single layer board (1s)	$R_{\theta JMA}$	24	°C/W	1, 3
Junction to Ambient (@200 ft/min)	Four layer board (2s2p)	$R_{\theta JMA}$	18.5	°C/W	1, 3
Junction to Board	—	$R_{\theta JB}$	7.8	°C/W	4
Junction to Case	—	$R_{\theta JC}$	4	°C/W	5
Junction to Package Top	Natural Convection	$\Psi_{JT}$	0.2	°C/W	6

<sup>1</sup> Junction temperature is a function of die size, on-chip power dissipation, package thermal resistance, mounting site (board) temperature, ambient temperature, air flow, power dissipation of other components on the board, and board thermal resistance.

<sup>2</sup> Per SEMI G38-87 and JESD51-2 with the single layer board horizontal.

<sup>3</sup> Per JEDEC JESD51-6 with the board horizontal.

<sup>4</sup> Thermal resistance between the die and printed circuit board per JEDEC JESD51-8. Board temperature is measured on the top surface of the board near the package.

<sup>5</sup> Thermal resistance between the die and the case top surface as measured by the cold plate method (MIL SPEC-883 Method 1012.1).

<sup>6</sup> Thermal characterization parameter indicating the temperature difference between package top and the junction temperature per JEDEC JESD51-2. When Greek letters are not available, the thermal characterization parameter is written as Psi-JT.

### 3.1.3 Operating ranges

Table 10 provides the operating ranges of the i.MX 8M Mini applications processor. For details on the chip's power structure, see the “Power Management Unit (PMU)” chapter of the *i.MX 8M Mini Applications Processor Reference Manual (IMX8MMRM)*.

Table 10. Operating ranges<sup>1</sup>

Symbol	Min	Typ	Max <sup>2,3</sup>	Unit	Comment
VDD_ARM	0.805	0.850	0.950	V	Power supply for Quad-A53, 1.2 GHz
	0.900	0.950	1.000	V	Power supply for Quad-A53, 1.6 GHz
	0.950	1.000	1.050	V	Power supply for Quad-A53, 1.8 GHz <sup>4</sup>
VDD_SOC without PCIE	0.780	0.820	0.900	V	Power supply for SoC logic <sup>5</sup>
VDD_SOC with PCIE	0.805	0.850	0.900	V	Power supply for SoC logic <sup>5</sup>
VDD_GPU	0.805	0.850	0.900	V	Power supply for 3D GPU, nominal mode, 800 MHz
	0.855	0.900	1.000	V	Power supply for 3D GPU, overdrive mode, 1000 MHz
VDD_VPU	—	—	—	—	Block G2/G1/H1
	0.805	0.850	0.900	V	Power supply for VPU, 450/450/450 MHz
	0.855	0.900	0.950	V	Power supply for VPU, 600/650/650 MHz
	0.900	0.950	1.000	V	Power supply for VPU, 700/750/750 MHz
VDD_DRAM	0.805	0.850	0.900	V	Power supply for DDRC, 0.85 V supports up to 1.0 GHz (DDR clock)
	0.855	0.900	0.950	V	Power supply for DDRC, 0.9 V supports up to 1.2 GHz (DDR clock)
	0.900	0.950	1.000	V	Power supply for DDRC, 0.95 V supports up to 1.5 GHz (DDR clock)
VDD_SNVS_0P8	0.760	0.800	0.900	V	Power supply for SNVS core logic
NVCC_SNVS_1P8	1.620	1.800	1.980	V	Power supply for GPIO pre-driver in SNVS bank
NVCC_JTAG, NVCC_GPIO1, NVCC_ENET, NVCC_SD1, NVCC_SD2, NVCC_NAND, NVCC_SAI1, NVCC_SAI2, NVCC_SAI3, NVCC_SAI5, NVCC_ECSPi, NVCC_I2C, NVCC_UART, NVCC_CLK	1.650	1.800	1.950	V	Power supply for GPIO when it is in 1.8 V mode
	3.000	3.300	3.600	V	Power supply for GPIO when it is in 3.3 V mode
NVCC_ENET	2.250	2.500	2.750	V	Power supply for GPIO when it is in 2.5 V mode

Table 10. Operating ranges<sup>1</sup> (continued)

Symbol	Min	Typ	Max <sup>2,3</sup>	Unit	Comment
PVCC0_1P8, PVCC1_1P8, PVCC2_1P8	1.650	1.800	1.950	V	Power supply for GPIO pre-driver
VSS	—	—	—	V	Ground for all core logic and I/O
NVCC_DRAM	1.283	1.35	1.425	V	DDR3L
	1.14	1.2	1.26	V	DDR4
	1.06	1.1	1.17	V	LPDDR4
DRAM_VREF	0.49 x NVCC_DRAM	0.5 x NVCC_DRAM	0.51 x NVCC_DRAM	V	Internal output, no connection is needed.
VDD_DRAM_PLL_0P8	0.805	0.850	1.000	V	0.8 V logic power supply for DSM. It should be connected to the separate logic power.
VDD_ANA0_1P8 VDD_ANA1_1P8	1.71	1.8	1.89	V	Analog 1.8 V core power
VDD_ANA_0P8	0.780	0.820	0.900	V	Isolated 0.8 V core power
VDD_ARM_PLL_0P8	0.780	0.820	0.900	V	Arm PLL 0.8 V power
VDD_ARM_PLL_1P8	1.71	1.8	1.89	V	Arm PLL 1.8 V power
VDD_24M_XTAL_1P8	1.71	1.8	1.89	V	XTAL 1.8 V power
VDD_DRAM_PLL_1P8	1.71	1.8	1.89	V	Analog 1.8 V core power
VDD_MIPI_0P9	0.855	0.9	1.000	V	0.9 V power for PLL and internal logic
VDD_MIPI_1P2	1.14	1.2	1.26	V	1.2 V power for analog
VDD_MIPI_1P8	1.71	1.8	1.89	V	1.8 V power for PLL and analog
VDD_PCI_0P8 <sup>6,7</sup>	0.805	0.850	0.900	V	Digital supply for PCIe PHY
VDD_PCI_1P8 <sup>6</sup>	1.71	1.800	1.890	V	1.8 V supply for PCIe PHY
VDD_USB_0P8	0.780	0.820	0.900	V	Digital power supply from PHY's I/O power pads
VDD_USB_1P8	1.71	1.80	1.89	V	1.8 V analog power supply
VDD_USB_3P3	3.069	3.30	3.6	V	3.3 V analog power supply
USB1_VBUS USB2_VBUS	1.34	—	3.60	V	USB_VBUS input detect signal
Temperature Sensor Accuracy <sup>8</sup>	—	±3	±5	°C	Sensing temperature range 10°C to 85°C
	—	±4	±6	°C	Sensing temperature range 10°C to 95°C
	—	±5	±7	°C	Sensing temperature range 10°C to 105°C

Table 10. Operating ranges<sup>1</sup> (continued)

Symbol	Min	Typ	Max <sup>2,3</sup>	Unit	Comment
TMU Sensing Temperature Range	10	—	125	°C	—
$T_J$	0	—	+95	°C	See Table 2 for complete list of junction temperature capabilities.

<sup>1</sup> The BD71847MWW PMIC does not support 0.950 V for VDD\_GPU, VDD\_VPU, and VDD\_DRAM. For this PMIC, 0.975 V typical is acceptable and supported.

<sup>2</sup> Applying the maximum voltage results in maximum power consumption and heat generation. A voltage set point = (Vmin + the supply tolerance) is recommended. This results in an optimized power/speed ratio.

<sup>3</sup> Overdrive maximum voltage includes all the nominal frequencies.

<sup>4</sup> 50% duty cycle for 5 years

<sup>5</sup> Booting VDD\_SOC at 0.800 V  $\pm$ 5% is acceptable (Vmin = 0.760 V). Software is expected to program the VDD\_SOC voltage to the typical value in this table prior to first DRAM memory access.

<sup>6</sup> Ensure the VDD\_PCI\_1P8 does not have more than 40 mVpp AC power supply noise superimposed on the high power supply voltage for the PHY core (1.8 V nominal DC value). Simultaneously, the VDD\_PCI\_0P8 should have no more than 20 mVpp AC power supply noise superimposed on the low power supply voltage for the PHY core (0.9 V nominal DC value for the overdrive).

<sup>7</sup> It can be min 0.78 V when supplied but not operating PCIe.

<sup>8</sup> "EN" of TMU Enable Register (TMU\_TER) is required to be always enabled for the part to operate correctly.

### 3.1.4 External clock sources

Each i.MX 8M Mini processor has two external input system clocks: a low frequency (RTC\_XTALI) and a high frequency (XTALI).

The RTC\_XTALI is used for low-frequency functions. It supplies the clock for wake-up circuit, power-down real time clock operation, and slow system and watch-dog counters. The clock input can only be connected to an external oscillator. RTC\_XTALO should be directly connected to VDD\_SNVS\_0P8.

The system clock input XTALI is used to generate the main system clock. It supplies the PLLs and other peripherals. The system clock input can be connected to either an external oscillator or a crystal using internal oscillator amplifier.

Table 11 shows the interface frequency requirements.

Table 11. External input clock frequency

Parameter Description	Symbol	Min	Typ	Max	Unit
RTC_XTALI Oscillator <sup>1</sup>	$f_{ckil}$	—	32.768 <sup>2</sup>	—	kHz
XTALI Oscillator <sup>1,3</sup>	$f_{xtal}$		24		MHz

<sup>1</sup> The required frequency stability of this clock source is application dependent.

<sup>2</sup> Recommended nominal frequency 32.768 kHz.

## Electrical characteristics

<sup>3</sup> External oscillator or a fundamental frequency crystal appropriately coupled to the internal oscillator amplifier.

The typical values shown in [Table 11](#) are required for use with NXP software to ensure precise time keeping and USB operation. For RTC\_XTALI operation, an external oscillator is necessary. RTC\_XTALO should be directly connected to VDD\_SNV5\_0P8 when using an external 32.768 kHz oscillator.

### NOTE

There is no internal RC oscillator.

[Table 12](#) shows the external input clock for OSC32K.

**Table 12. External input clock for OSC32K**

	Symbol	Min	Typ	Max	Unit
Frequency	f	—	32.768	—	kHz
RTC_XTALI	VIH	0.7 x NVCC_SNV5_1P8	—	NVCC_SNV5_1P8	V
	VIL	0	—	0.3 x NVCC_SNV5_1P8	V

### 3.1.5 Maximum supply currents

Power consumption is highly dependent on the application. Estimating the maximum supply currents required for power supply design is difficult because the use cases that requires maximum supply current is not a realistic use cases.

To help illustrate the effect of the application on power consumption, data was collected while running consumer standard benchmarks that are designed to be compute and graphic intensive. The results provided are intended to be used as guidelines for power supply design.

**Table 13. Maximum supply currents**

Power rail	Max current	Unit
VDD_ARM	2200	mA
VDD_SOC	1000	mA
VDD_GPU	500	mA
VDD_VPU	1000	mA
VDD_DRAM	1000	mA
VDD_ANA_0P8	50	mA
VDD_ANA0_1P8 VDD_ANA1_1P8	250	mA
NVCC_SNV5_1P8	3	mA
VDD_ARM_PLL_1P8 VDD_24M_XTAL_1P8	100	mA
PVCCx_1P8	3	mA

Table 13. Maximum supply currents (continued)

Power rail	Max current	Unit
NVCC_<XXX>	$I_{\max} = N \times C \times V \times (0.5 \times F)$ Where: N—Number of IO pins supplied by the power line C—Equivalent external capacitive load V—IO voltage (0.5 x F)—Data change rate. Up to 0.5 of the clock rate (F). In this equation, $I_{\max}$ is in Amps, C in Farads, V in Volts, and F in Hertz.	
NVCC_DRAM		
DRAM_VFEF	10	mA

### 3.1.6 Power modes

The i.MX 8M Mini processors support the following power modes:

- **RUN Mode:** All external power rails are on, CPU is active and running; other internal modules can be on/off based on application.
- **IDLE Mode:** When there is no thread running and all high-speed devices are not active, the CPU can automatically enter this mode. The CPU can be in the power-gated state but with L2 data retained, DRAM and the bus clock are reduced. Most of the internal logic is clock gated but still remains powered. The M4 core can remain running. Compared with RUN mode, all the external power rails from the PMIC remain the same, and most of the modules still remain in their state.
- **SUSPEND Mode:** The most efficient power saving mode where all the clocks are off and all the unnecessary power supplies are off.
- **SNVS Mode:** This mode is also called RTC mode. Only the power for the SNVS domain remains on to keep RTC and SNVS logic alive.
- **OFF Mode:** All power rails are off.

Table 14. Chip power in different LP mode

Mode	Supply	Typ. <sup>1</sup>	Unit
SNVS	VDD_SNVS_0P8 (0.8 V)	0.02	mW
	NVCC_SNVS_1P8 (1.8 V)	0.09	
	Total <sup>2</sup>	0.11	

## Electrical characteristics

**Table 14. Chip power in different LP mode (continued)**

Mode	Supply	Typ. <sup>1</sup>	Unit
SUSPEND	NVCC (1.8 V)	1.20	mW
	NVCC_DRAM (1.1 V)	0.50	
	NVCC_ENET (1.8 V)	0.10	
	NVCC_SNVS_1P8 (1.8 V)	0.10	
	PVCC (1.8 V)	0.60	
	VDD_MIPI_0P9 (0.9 V)	2.20	
	VDD_SNVS_0P8 (0.8 V)	0.10	
	VDD_SOC (0.82 V)	4.00	
	VDD_ARM_0P8 (0.82 V)	0.10	
	VDDA_PCIE_USB_0P8 (0.82 V)	3.00	
	Total <sup>2</sup>	11.90	

<sup>1</sup> All the power numbers defined in the table are for information only. These numbers are based on typical silicon at 25°C, under non-OS environment and use case dependent. For power numbers with OS and real use cases, see *Power consumption measurement application note* for more details.

<sup>2</sup> Sum of the listed supply rails.

Table 15 summarizes the external power supply states in all the power modes.

**Table 15. The power supply states**

Power rail	OFF	SNVS	SUSPEND	IDLE	RUN
VDD_ARM	OFF	OFF	OFF	ON	ON
VDD_SOC	OFF	OFF	ON	ON	ON
VDD_GPU	OFF	OFF	OFF	OFF	ON/OFF
VDD_VPU	OFF	OFF	OFF	OFF	ON/OFF
VDD_DRAM	OFF	OFF	OFF	ON	ON
Misc_1P8 <sup>1</sup>	OFF	OFF	ON	ON	ON
Misc_0P8 <sup>1</sup>	OFF	OFF	ON	ON	ON
VDD_MIPI_1P2	OFF	OFF	OFF	ON	ON
VDD_MIPI_0P9	OFF	OFF	OFF	ON	ON
VDD_DRAM_PLL_0P8	OFF	OFF	ON	ON	ON
VDD_SNVS_0P8	OFF	ON	ON	ON	ON
NVCC_SNVS_1P8	OFF	ON	ON	ON	ON
NVCC_<XXX>	OFF	OFF	ON	ON	ON

Table 15. The power supply states (continued)

Power rail	OFF	SNVS	SUSPEND	IDLE	RUN
PVCCx_1P8	OFF	OFF	ON	ON	ON
NVCC_DRAM	OFF	OFF	ON	ON	ON

<sup>1</sup> See Table 16

Table 16. Group name

Misc_1P8	VDD_24M_XTAL_1P8 VDD_ANA0_1P8 VDD_ANA1_1P8 VDD_ARM_PLL_1P8 VDD_DRAM_PLL_1P8 VDD_MIPI_1P8 VDD_PCI_1P8 VDD_USB_1P8
Misc_0P8	VDD_ANA_0P8 VDD_ARM_PLL_0P8 VDD_PCI_0P8 VDD_USB_0P8

## 3.2 Power supplies requirements and restrictions

The system design must comply with power-up sequence, power-down sequence, and steady state guidelines as described in this section to guarantee the reliable operation of the device. Any deviation from these sequences may result in the following situations:

- Excessive current during power-up phase
- Prevention of the device from booting
- Irreversible damage to the processor (worst-case scenario)

### 3.2.1 Power-up sequence

Figure 6 illustrates the power-up sequence of i.MX 8M Mini processor.

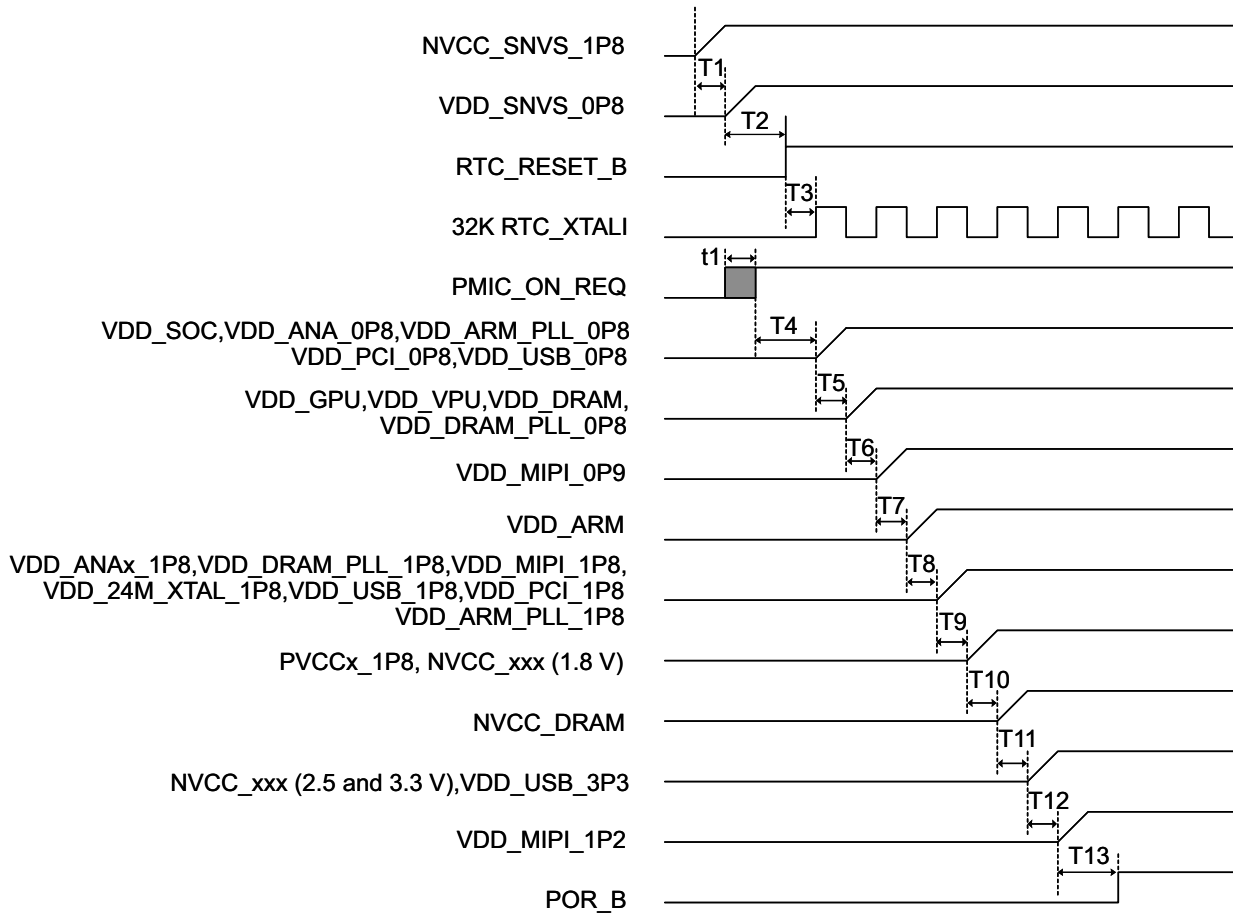

Figure 3. The power-up sequence

#### NOTE

VDD\_MIPI\_1P2 should power up after VDD\_MIPI\_0P8 and VDD\_MIPI\_1P8, and it can power up before the POR\_B release or after POR\_B release.

Table 17 represents the timing parameters of the power-up sequence.

**Table 17. Power-up sequence**

	Description	Min	Typ	Max	Unit
T1	Delay from NVCC_SNVS_1P8 to VDD_SNVS_0P8	0	2	—	ms
T2	Delay from VDD_SNVS_0P8 high or RTC_SET_B de-assert	0	10	—	ms
T3	Delay from RTC_RESET_B de-assert to stable 32 k existed	—	40	100	μs
T4	Delay from PMIC_ON_REQ assert to analog 0.8 V on	0	0.2	—	ms
T5	Delay from analog 0.8 V on to analog 0.8/0/9 V on	0	2	—	ms
T6	Delay from analog 0.8/0.9 V on to PHY 0.9 V on	0	15	—	μs
T7	Delay from PHY 0.9 V on to VDD_ARM on	0	2	—	ms
T8	Delay from VDD_ARM on to analog 1.8 V on	0	15	—	μs
T9	Delay from analog 1.8 V on to digital 1.8 V on	0	2	—	ms
T10	Delay from digital 1.8 V on to NVCC_DRAM on	0	2	—	ms
T11	Delay from NVCC_DRAM on to digital 2.5 V and 3.3 V on	0	2	—	ms
T12	Delay from digital 2.5 V and 3.3 V on to PHY 1.2 V on	0	2	—	ms
T13 <sup>1</sup>	Delay from PHY 1.2 V on to POR_B de-assert	0	20	—	ms
t1	Uncertain period before PMIC_ON_REQ assert during VDD_SNVS_0P8 ramp up.				
	For ramp up requirement, only VDD_ANA0_1P8 has 5 μs minimum requirement, others do not have such requirement. During power-up, make sure NVCC_xxx - PVCCx_1P8 < 2 V.				

<sup>1</sup> The values of T13 depend on T2. RTC\_RESET\_B must be de-assert before POR\_B de-asserts.

### 3.2.2 Power-down sequence

Figure 6 illustrates the power-down sequence of i.MX 8M Mini processor.

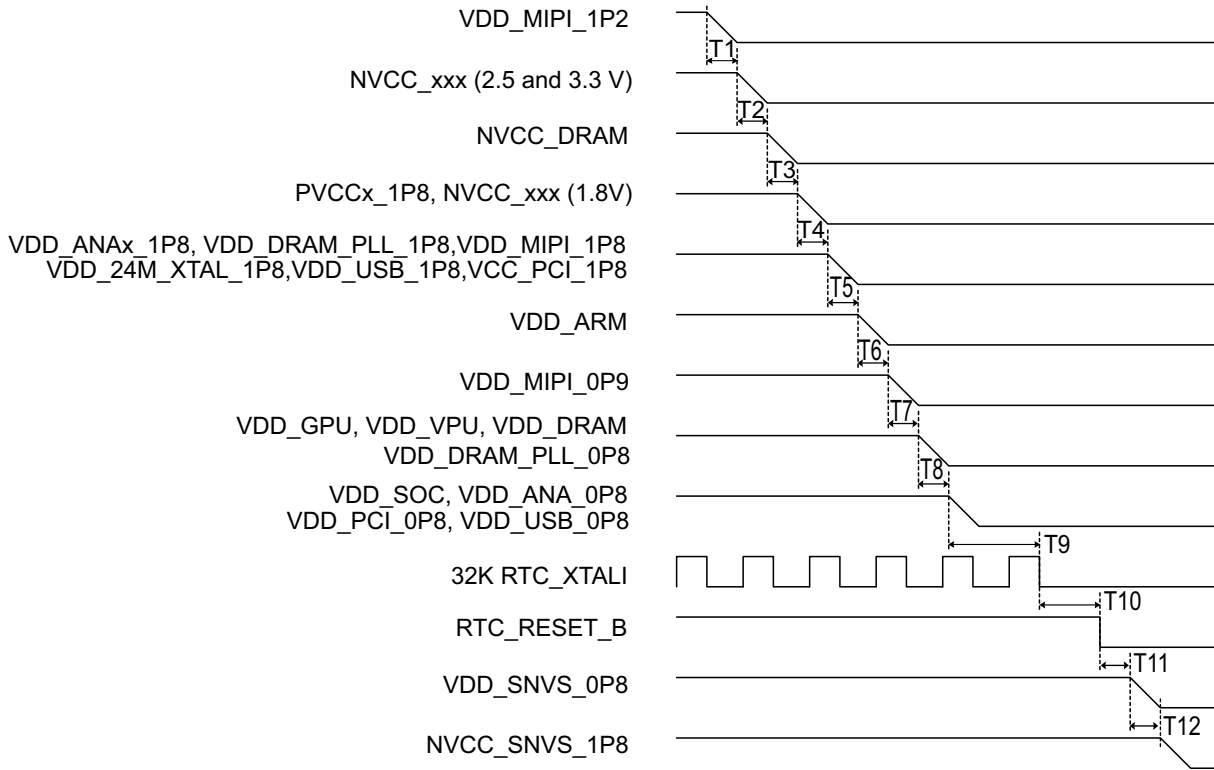

Figure 4. The power-down sequence

**NOTE**

VDD\_MIPI\_1P2 should be powered down before VDD\_MIPI\_1P8, no other strict requirement with other power rails.

Table 18 represents the timing parameters of the power-down sequence.

**Table 18. Power-down sequence**

	Description	Min	Typ	Max	Unit
T1	Delay from PHY 1.2 V off to digital 2.5 V and 3.3 V off	0	10	—	ms
T2	Delay from digital 2.5 V and 3.3 V off to NVCC_DRAM off	0	10	—	ms
T3	Delay from NVCC_DRAM off to digital 1.8 V off	0	10	—	ms
T4	Delay from digital 1.8 V off to analog 1.8 V off	0	10	—	ms
T5	Delay from analog 1.8 V off to VDD_ARM off	0	10	—	ms
T6	Delay from VDD_ARM off to PHY 0.9 V off	0	10	—	ms
T7	Delay from PHY 0.9 V off to analog 0.8/0.9 V off	0	10	—	ms
T8	Delay from analog 0.8/0.9 V off to analog 0.8 V off	0	10	—	ms
T9	Delay from analog 0.8 V off to 32k off	0	10	—	ms
T10	Delay from 32k off to RTC_RESET_B assert	0	10	—	ms
T11	Delay from RTC_RESET_B assert to VDD_SNVS_0P8 off	0	10	—	ms
T12	Delay from VDD_SNVS_0P8 off to NVCC_SNVS_1P8 off	0	10	—	ms
	During power-down, make sure NVCC_xxx - PVCCx_1P8 < 2 V.				

### 3.3 PLL electrical characteristics

Table 19 shows PLL electrical characteristics.

**Table 19. PLL electrical parameters**

PLL type	Parameter	Value
AUDIO_PLL1	Clock output range	Maximum 650 MHz
	Reference clock	24 MHz
	Lock time	375 $\mu$ s
AUDIO_PLL2	Clock output range	Maximum 650 MHz
	Reference clock	24 MHz
	Lock time	375 $\mu$ s
VIDEO_PLL1	Clock output range	Maximum 650 MHz
	Reference clock	24 MHz
	Lock time	375 $\mu$ s
SYS_PLL1	Clock output range	800 MHz
	Reference clock	24 MHz
	Lock time	25 $\mu$ s

Table 19. PLL electrical parameters (continued)

PLL type	Parameter	Value
SYS_PLL2	Clock output range	1 GHz
	Reference clock	24 MHz
	Lock time	25 $\mu$ s
SYS_PLL3	Clock output range	600 MHz ~ 1 GHz
	Reference clock	24 MHz
	Lock time	25 $\mu$ s
ARM_PLL	Clock output range	800 MHz ~1.6 GHz
	Reference clock	24 MHz
	Lock time	25 $\mu$ s
DRAM_PLL	Clock output range	Maximum 750 MHz
	Reference clock	24 MHz
	Lock time	375 $\mu$ s
GPU_PLL	Clock output range	Maximum 1 GHz
	Reference clock	24 MHz
	Lock time	25 $\mu$ s
VPU_PLL	Clock output range	400 MHz ~ 800 MHz
	Reference clock	24 MHz
	Lock time	25 $\mu$ s

## 3.4 On-chip oscillators

### 3.4.1 OSC24M

A 24 MHz oscillator is used as the primary clock source for the PLLs to generate the clock for the CPU, BUS, and high-speed interfaces. For fractional PLLs, the 24 MHz clock from the oscillator can be used as the PLL reference clock directly.

Table 20. Crystal specifications<sup>1</sup>

Parameter Description	Min	Typ	Max	Unit
Frequency	—	24	—	MHz
Clload	—	12	—	pF
Drive level	10.02	—	100	$\mu$ W
ESR	—	—	60	$\Omega$

<sup>1</sup> Actual working drive level is depend on real design. Please contact crystal vendor for selecting drive level of crystal.

### 3.4.2 OSC32K

This block implements an amplifier that when combined with a suitable quartz crystal and external load capacitors implements a low power oscillator.

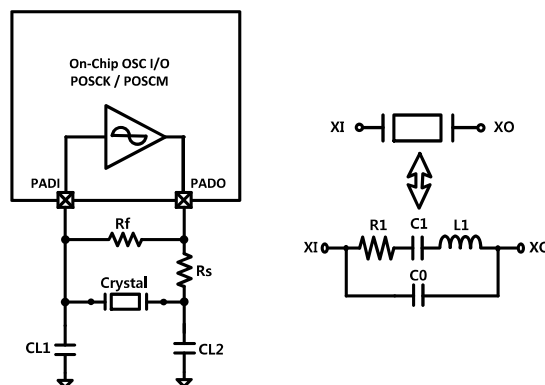

Figure 5. Crystal model and external components

Table 21. 32K crystal specifications<sup>1</sup>

Parameter Description	Min	Typ	Max	Unit
Frequency	—	32.768	—	kHz
Clload <sup>1</sup>	—	12.5	—	pF
Drive level <sup>2</sup>	17.74	—	1000	nW
ESR <sup>3</sup>	—	—	70K	$\Omega$
Rf (feedback resistor) <sup>4</sup>	4.7	—	—	M $\Omega$
Rs (series resistor) <sup>5</sup>	0	—	1	M $\Omega$

<sup>1</sup> CL is the load capacitance of the crystal that is recommended by the crystal vendors to obtain target clock frequency. CL is given by the following formula:  $CL = \{CL1 \times CL2 / (CL1 + CL2)\} + PCB \text{ strays}$ .

<sup>2</sup> Actual working drive level is depend on real design. Please contact crystal vendor for selecting drive level of crystal.

<sup>3</sup> ESR is the equivalent series resistance of the crystal.

<sup>4</sup> Rf is the feedback resistor to bias the amplifier. A larger value of Rf is preferred at lower frequencies.

<sup>5</sup> Rs is the series resistor to limit amplifier gain and reduce power dissipation in the crystal.

## 3.5 General purpose I/O (GPIO) DC parameters

Table 22 shows DC parameters for GPIO pads. The parameters in Table 22 are guaranteed per the operating ranges in Table 10, unless otherwise noted.

Table 22. GPIO DC parameters

Parameter	Symbol	Test Conditions	Min	Typ	Max	Unit
High-level output voltage	$V_{OH(1.8V)}$	$I_{OH} = 1.6/3.2/6.4/9.6 \text{ mA (1.8 V)}$ $I_{OH} = 2/4/8/12 \text{ mA (3.3 V)}$	$0.8 \times V_{DD}$	—	$V_{DD}$	V
	$V_{OH(3.3V)}$		$0.8 \times V_{DD}$	—	$V_{DD}$	V
Low-level output voltage	$V_{OL(1.8V)}$	$I_{OL} = 1.6/3.2/6.4/9.6 \text{ mA (1.8 V)}$ $I_{OL} = 2/4/8/12 \text{ mA (3.3 V)}$	0	—	$0.2 \times V_{DD}$	V
	$V_{OL(3.3V)}$		0	—	$0.2 \times V_{DD}$	V
High-level input voltage	$V_{IH}$	—	$0.7 \times V_{DD}$	—	$V_{DD} + 0.3$	V
Low-level input voltage	$V_{IL}$	—	-0.3	—	$0.3 \times V_{DD}$	V
Pull-up resistor	—	$V_{DD} = 1.65 - 1.95V$ Temp = 0 - 95 °C	12	22	49	K $\Omega$
Pull-down resistor	—		13	23	48	K $\Omega$
Pull-up resistor	—	$V_{DD} = 2.25 - 2.75V$ Temp = 0 - 95 °C	13	24	69	K $\Omega$
Pull-down resistor	—		9.1	33	69	K $\Omega$
Pull-up resistor <sup>1</sup>	—	$V_{DD} = 3.0 - 3.6V$ Temp = 0 - 95 °C	—	—	—	K $\Omega$
Pull-down resistor <sup>1</sup>	—		—	—	—	K $\Omega$
High level input current	I <sub>IH</sub>	—	-4	—	4	$\mu\text{A}$
Low level input current	I <sub>IL</sub>	—	-0.7	—	0.7	$\mu\text{A}$

<sup>1</sup> Does not support internal pull-up or pull-down for 3.3 V IOs.

Table 23. Additional leakage parameters

Parameter	Symbol	Pins	Min	Max	Unit
High level input current	I <sub>IH</sub>	PCIE_RXN, USBx_Dx	-30	30	$\mu\text{A}$
		PCIE_CLK	-8	8	
		MIPI_CSI	-4	4	
Low level input current	I <sub>IL</sub>	JTAG_TRST_B, USBx_ID	-200	200	$\mu\text{A}$
		PCIE_CLK, USBx_Dx	-6	6	
		PCIE_RXN	-2.5	2.5	
		MIPI_CSI, ONOFF, POR_B	-0.7	0.7	

### 3.5.1 DDR I/O DC electrical characteristics

The DDR I/O pads support LPDDR 4, DDR4, and DDR3L operational modes. The DDR Memory Controller (DDRMC) is designed to be compatible with JEDEC-compliant SDRAMs.

DDRMC operation is contingent upon the board's DDR design adherence to the DDR design and layout requirements stated in the hardware development guide for the i.MX 8M Mini applications processor.

### 3.6 I/O AC parameters

This section includes the AC parameters of the following I/O types:

- General Purpose I/O (GPIO)

The GPIO load circuit and output transition time waveforms are shown in [Figure 6](#) and [Figure 7](#).

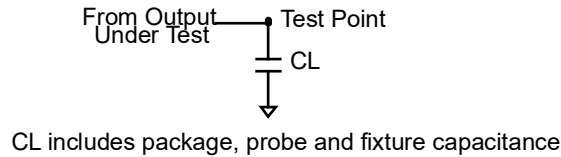

**Figure 6. Load circuit for output**

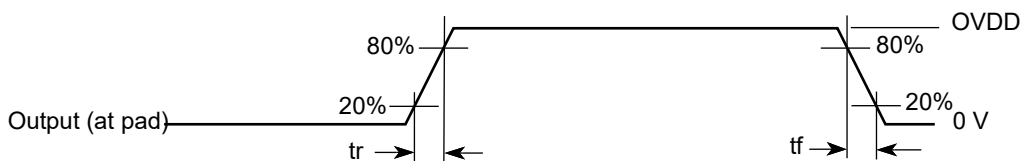

**Figure 7. Output transition time waveform**

#### 3.6.1 General purpose I/O AC parameters

This section presents the I/O AC parameters for GPIO in different modes.

**Table 24. Maximum frequency of operation for input**

Maximum frequency (MHz)	
VDD = 1.8 V, CL = 50 pF	VDD = 3.3 V, CL = 50 pF
450	440

**Table 25. Maximum frequency of operation for output**

Parameter			Maximum Frequency (MHz)			
			VDD = 1.8 V		VDD = 3.3 V	
dse[2:0]	sre[1:0]	Driver type	CL = 10 pF	CL = 20 pF	CL = 10 pF	CL = 20 pF
00X	0X	1x Slow Slew	150	80	120	65
00X	1X	1x Fast Slew	150	80	120	65
10X	0X	2x Slow Slew	160	90	150	80
10X	1X	2x Fast Slew	160	90	150	80
01X	0X	4x Slow Slew	200	100	180	90

Table 25. Maximum frequency of operation for output (continued)

Parameter			Maximum Frequency (MHz)			
			VDD = 1.8 V		VDD = 3.3 V	
dse[2:0]	sre[1:0]	Driver type	CL = 10 pF	CL = 20 pF	CL = 10 pF	CL = 20 pF
01X	1X	4x Fast Slew	200	100	180	90
11X	0X	6x Slow Slew	250	130	200	100
11X	1X	6x Fast Slew	250	130	200	100

### 3.7 Output buffer impedance parameters

This section defines the I/O impedance parameters of the i.MX 8M Mini family of processors for the following I/O types:

#### NOTE

DDR I/O output driver impedance is measured with “long” transmission line of impedance  $Z_{tl}$  attached to I/O pad and incident wave launched into transmission line.  $R_{pu}/R_{pd}$  and  $Z_{tl}$  form a voltage divider that defines specific voltage of incident wave relative to OVDD. Output driver impedance is calculated from this voltage divider (see [Figure 8](#)).

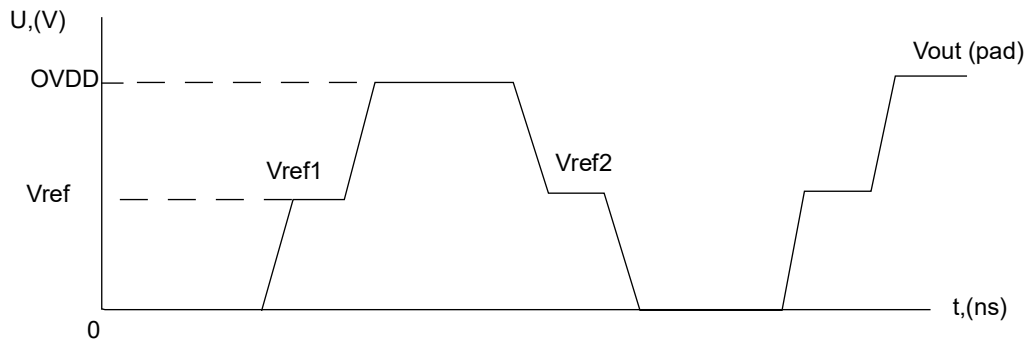
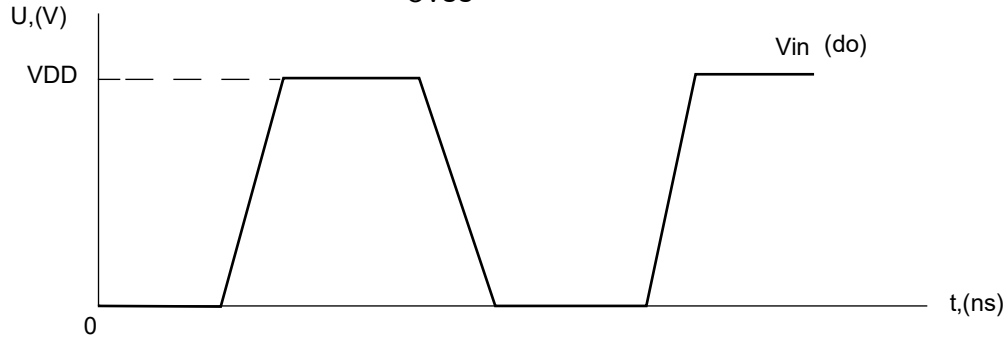
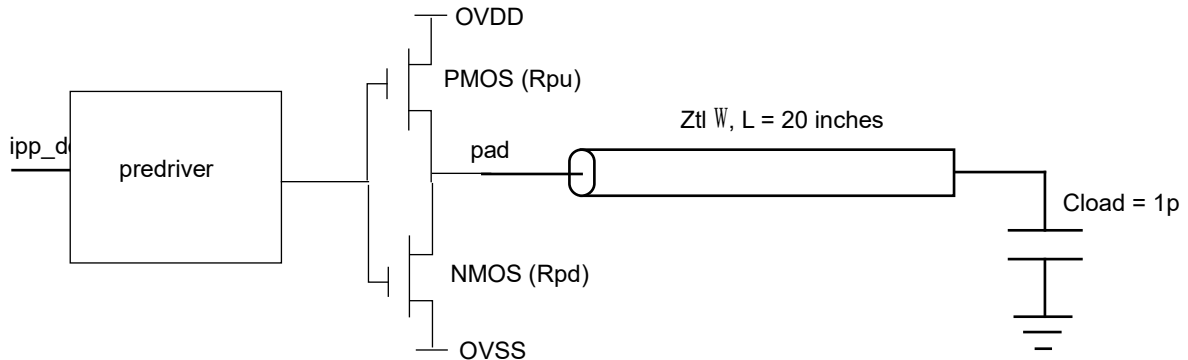

$$R_{pu} = \frac{V_{ovdd} - V_{ref1}}{V_{ref1}} \times Z_{tl}$$

$$R_{pd} = \frac{V_{ref2}}{V_{ovdd} - V_{ref2}} \times Z_{tl}$$

**Figure 8. Impedance matching load for measurement**

### 3.7.1 DDR I/O output buffer impedance

Table 26 shows DDR I/O output buffer impedance of i.MX 8M Mini family of processors.

Table 26. DDR I/O output buffer impedance

Parameter	Symbol	Test Conditions DSE (Drive Strength)	Typical			Unit
			NVCC_DRAM = 1.35 V (DDR3L)	NVCC_DRAM = 1.2 V (DDR4)	NVCC_DRAM = 1.1 V (LPDDR4)	
Output Driver Impedance	Rdrv	000000	Hi-Z	Hi-Z	Hi-Z	Ω
		000010	240	240	240	
		001000	120	120	120	
		001010	80	80	80	
		011000	60	60	60	
		011010	48	48	48	
		111000	40	40	40	
		111010	34	34	34	

**Note:**

1. Output driver impedance is controlled across PVTs using ZQ calibration procedure.
2. Calibration is done against 240 Ω external reference resistor.
3. Output driver impedance deviation (calibration accuracy) is ±5% (max/min impedance) across PVTs.

### 3.8 System modules timing

This section contains the timing and electrical parameters for the modules in each i.MX 8M Mini processor.

#### 3.8.1 Reset timings parameters

Figure 9 shows the reset timing and Table 27 lists the timing parameters.

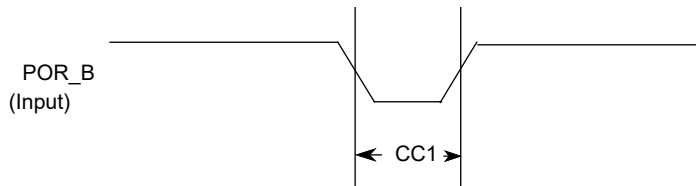

Figure 9. Reset timing diagram

Table 27. Reset timing parameters

ID	Parameter	Min	Max	Unit
CC1	Duration of POR_B to be qualified as valid.	1	—	RTC_XTALI cycle

### 3.8.2 WDOG Reset timing parameters

Figure 10 shows the WDOG reset timing and Table 28 lists the timing parameters.

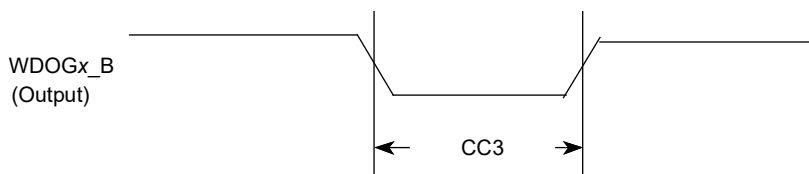

Figure 10. WDOGx\_B timing diagram

Table 28. WDOGx\_B timing parameters

ID	Parameter	Min	Max	Unit
CC3	Duration of WDOGx_B Assertion	1	—	RTC_XTALI cycle

#### NOTE

RTC\_XTALI is approximately 32 kHz. RTC\_XTALI cycle is one period or approximately 30  $\mu$ s.

#### NOTE

WDOGx\_B output signals (for each one of the Watchdog modules) do not have dedicated pins, but are muxed out through the IOMUX. See the IOMUXC chapter of the *i.MX 8M Mini Applications Processor Reference Manual* (IMX8MMRM) for detailed information.

### 3.8.3 DDR SDRAM–specific parameters (LPDDR4 and DDR4)

The i.MX 8M Mini Family of processors have been designed and tested to work with JEDEC JESD209-4A–compliant LPDDR4 memory and JESD79-4A compliant DDR4 memory. Timing diagrams and tolerances required to work with these memories are specified in the respective documents and are not reprinted here.

Meeting the necessary timing requirements for a DDR memory system is highly dependent on the components chosen and the design layout of the system as a whole. NXP cannot cover in this document all the requirements needed to achieve a design that meets full system performance over temperature, voltage, and part variation; PCB trace routing, PCB dielectric material, number of routing layers used, placement of bulk/decoupling capacitors on critical power rails, VIA placement, GND and Supply planes layout, and DDR controller/PHY register settings all are factors affecting the performance of the memory system. Consult the hardware user guide for this device and NXP validated design layouts for information on how to properly design a PCB for best DDR performance. NXP strongly recommends duplicating an NXP validated design as much as possible in the design of critical power rails, placement of bulk/decoupling capacitors and DDR trace routing between the processor and the selected DDR memory. All supporting material is readily available on the device web page on <https://www.nxp.com/products/processors-and-microcontrollers/applications-processors/i.mx-applications-processors/i.mx-8-processors:IMX8-SERIES>.

## Electrical characteristics

Processors that demonstrate full DDR performance on NXP validated designs, but do not function on customer designs, are not considered marginal parts. A report detailing how the returned part behaved on an NXP validated system will be provided to the customer as closure to a customer's reported DDR issue. Customers bear the responsibility of properly designing the Printed Circuit Board, correctly simulating and modeling the designed DDR system, and validating the system under all expected operating conditions (temperatures, voltages) prior to releasing their product to market.

**Table 29. i.MX 8M Mini DRAM controller supported SDRAM configurations**

Parameter	LPDDR4	DDR4
Number of Controllers	1	1
Number of Channels	2	N/A
Number of Chip Selects	2	1
Bus Width	32 bit	32 bit
Maximum Clock Frequency	3000 MT/s	2400 MT/s

### 3.8.3.1 Clock/data/command/address pin allocations

These processors use generic names for clock, data, and command address bus (DCF—DRAM controller functions); see [Table 69](#) for details about mapping of clock, data, and command address signals of LPDDR4 and DDR4 modes.

## 3.9 External peripheral interface parameters

The following subsections provide information on external peripheral interfaces.

### 3.9.1 ECSPi timing parameters

This section describes the timing parameters of the ECSPi blocks. The ECSPi have separate timing parameters for master and slave modes.

### 3.9.1.1 ECSPi Master mode timing

Figure 11 depicts the timing of ECSPi in master mode. Table 30 lists the ECSPi master mode timing characteristics.

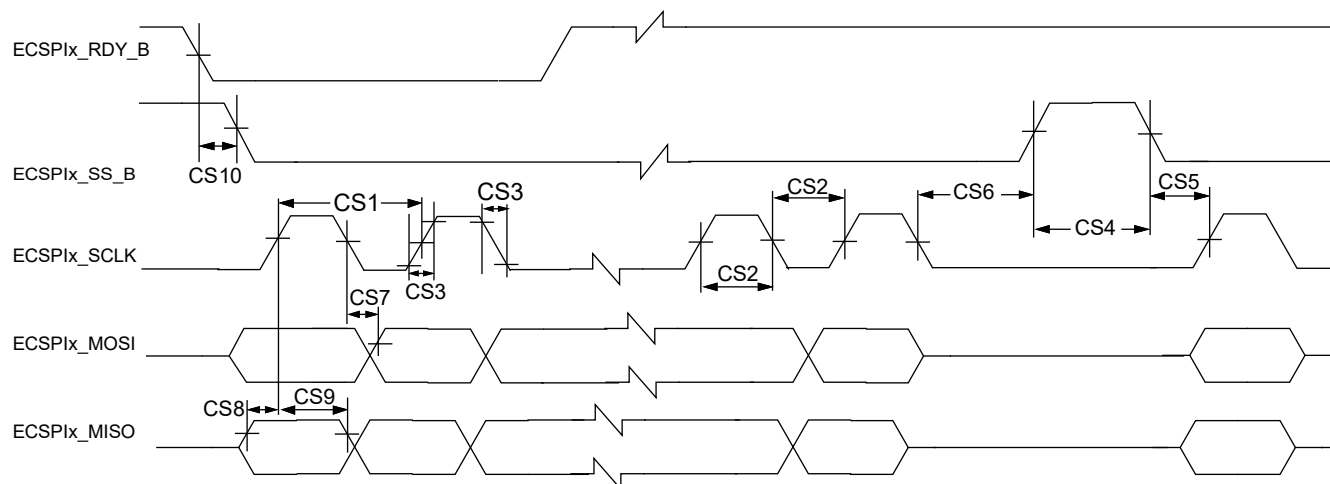

Figure 11. ECSPi Master mode timing diagram

Table 30. ECSPi Master mode timing parameters

ID	Parameter	Symbol	Min	Max	Unit
CS1	ECSPi_SCLK Cycle Time–Read ECSPi_SCLK Cycle Time–Write	$t_{clk}$	43 15	—	ns
CS2	ECSPi_SCLK High or Low Time–Read ECSPi_SCLK High or Low Time–Write	$t_{sw}$	21.5 7	—	ns
CS3	ECSPi_SCLK Rise or Fall <sup>1</sup>	$t_{RISE/FALL}$	—	—	ns
CS4	ECSPi_SS_B pulse width	$t_{CSLH}$	Half ECSPi_SCLK period	—	ns
CS5	ECSPi_SS_B Lead Time (CS setup time)	$t_{SCS}$	Half ECSPi_SCLK period - 4	—	ns
CS6	ECSPi_SS_B Lag Time (CS hold time)	$t_{HCS}$	Half ECSPi_SCLK period - 2	—	ns
CS7	ECSPi_MOSI Propagation Delay ( $C_{LOAD} = 20$ pF)	$t_{PDmosi}$	-1	1	ns
CS8	ECSPi_MISO Setup Time	$t_{Smiso}$	18	—	ns
CS9	ECSPi_MISO Hold Time	$t_{Hmiso}$	0	—	ns
CS10	RDY to ECSPi_SS_B Time <sup>2</sup>	$t_{SDRY}$	5	—	ns

<sup>1</sup> See specific I/O AC parameters [Section 3.6, I/O AC parameters.](#)

<sup>2</sup> SPI\_RDY is sampled internally by ipg\_clk and is asynchronous to all other CSPI signals.

### 3.9.1.2 ECSPi Slave mode timing

Figure 12 depicts the timing of ECSPi in Slave mode. Table 31 lists the ECSPi Slave mode timing characteristics.

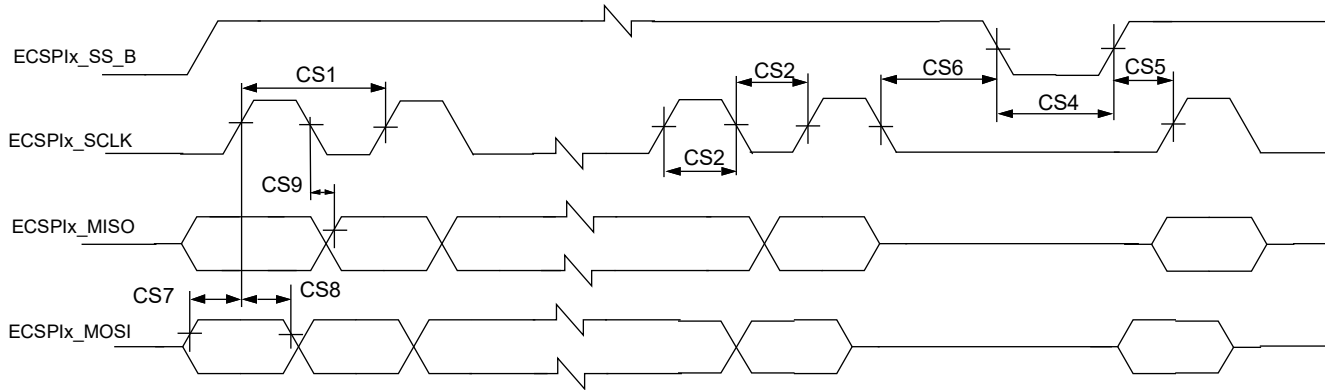

Figure 12. ECSPi Slave mode timing diagram

Table 31. ECSPi Slave mode timing parameters

ID	Parameter	Symbol	Min	Max	Unit
CS1	ECSPi_SCLK Cycle Time–Read ECSPi_SCLK Cycle Time–Write	$t_{clk}$	15 43	—	ns
CS2	ECSPi_SCLK High or Low Time–Read ECSPi_SCLK High or Low Time–Write	$t_{sw}$	7 21.5	—	ns
CS4	ECSPi_SS_B pulse width	$t_{CSLH}$	Half ECSPi_SCLK period	—	ns
CS5	ECSPi_SS_B Lead Time (CS setup time)	$t_{SCS}$	5	—	ns
CS6	ECSPi_SS_B Lag Time (CS hold time)	$t_{HCS}$	5	—	ns
CS7	ECSPi_MOSI Setup Time	$t_{Smosi}$	4	—	ns
CS8	ECSPi_MOSI Hold Time	$t_{Hmosi}$	4	—	ns
CS9	ECSPi_MISO Propagation Delay ( $C_{LOAD} = 20\text{ pF}$ )	$t_{PDmiso}$	4	19	ns

### 3.9.2 Ultra-high-speed SD/SDIO/MMC host interface (uSDHC) AC timing

This section describes the electrical information of the uSDHC, which includes SD/eMMC 5.1 (single data rate) timing, eMMC 5.1/SD3.0 (dual data rate) AC timing, and SDR50/SDR104 AC timing.

#### 3.9.2.1 SD3.0/eMMC 5.1 (single data rate) AC timing

Figure 13 depicts the timing of SD3.0/eMMC5.1 (SDR), and Table 32 lists the SD3.0/eMMC5.1 (SDR) timing characteristics.

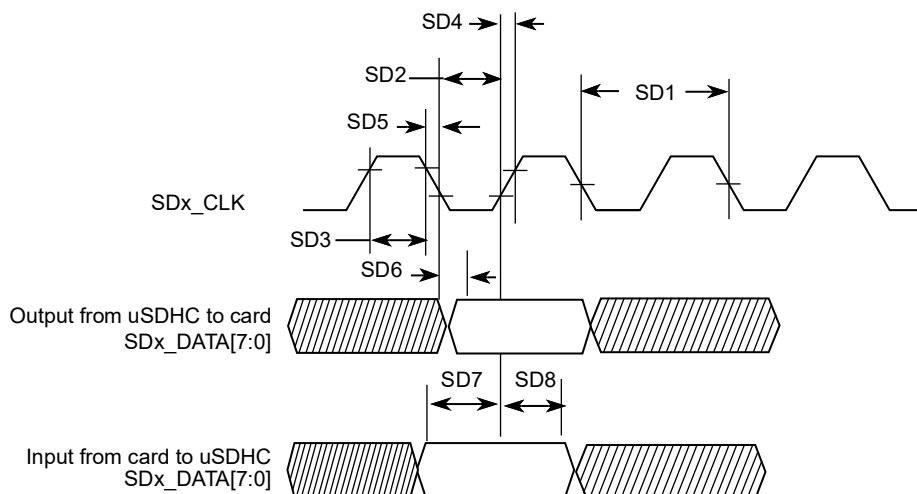

Figure 13. SD3.0/eMMC5.1 (SDR) timing

Table 32. SD3.0/eMMC5.1 (SDR) interface timing specification

ID	Parameter	Symbols	Min	Max	Unit
<b>Card Input Clock</b>					
SD1	Clock Frequency (Low Speed)	$f_{PP}^1$	0	400	kHz
	Clock Frequency (SD/SDIO Full Speed/High Speed)	$f_{PP}^2$	0	25/50	MHz
	Clock Frequency (MMC Full Speed/High Speed)	$f_{PP}^3$	0	20/52	MHz
	Clock Frequency (Identification Mode)	$f_{OD}$	100	400	kHz
SD2	Clock Low Time	$t_{WL}$	7	—	ns
SD3	Clock High Time	$t_{WH}$	7	—	ns
SD4	Clock Rise Time	$t_{TLH}$	—	3	ns
SD5	Clock Fall Time	$t_{THL}$	—	3	ns
<b>uSDHC Output/Card Inputs SD_CMD, SDx_DATAx (Reference to CLK)</b>					
SD6	uSDHC Output Delay	$t_{OD}$	-6.6	3.6	ns

**Table 32. SD3.0/eMMC5.1 (SDR) interface timing specification (continued)**

ID	Parameter	Symbols	Min	Max	Unit
<b>uSDHC Input/Card Outputs SD_CMD, SDx_DATAx (Reference to CLK)</b>					
SD7	uSDHC Input Setup Time	$t_{ISU}$	2.5	—	ns
SD8	uSDHC Input Hold Time <sup>4</sup>	$t_{IH}$	1.5	—	ns

- <sup>1</sup> In Low-Speed mode, card clock must be lower than 400 kHz, voltage ranges from 2.7 to 3.6 V.
- <sup>2</sup> In Normal (Full) -Speed mode for SD/SDIO card, clock frequency can be any value between 0–25 MHz. In High-speed mode, clock frequency can be any value between 0–50 MHz.
- <sup>3</sup> In Normal (Full) -Speed mode for MMC card, clock frequency can be any value between 0–20 MHz. In High-speed mode, clock frequency can be any value between 0–52 MHz.
- <sup>4</sup> To satisfy hold timing, the delay difference between clock input and cmd/data input must not exceed 2 ns.

### 3.9.2.2 eMMC 5.1/SD3.0 (dual data rate) AC timing

Figure 14 depicts the timing of eMMC 5.1/SD3.0 (DDR). Table 33 lists the eMMC 5.1/SD3.0 (DDR) timing characteristics. Be aware that only DATA is sampled on both edges of the clock (not applicable to CMD).

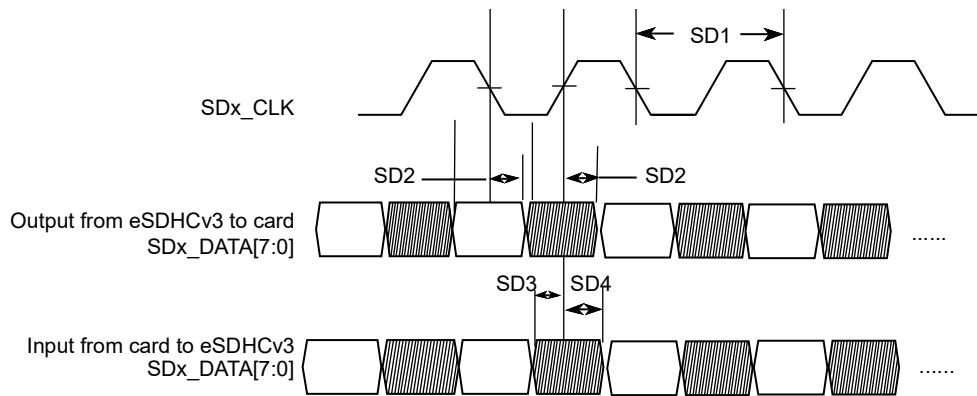

**Figure 14. eMMC5.1/SD3.0 (DDR) timing**

**Table 33. eMMC5.1/SD3.0 (DDR) interface timing specification**

ID	Parameter	Symbols	Min	Max	Unit
<b>Card Input Clock</b>					
SD1	Clock Frequency (eMMC5.1 DDR)	$f_{PP}$	0	52	MHz
SD1	Clock Frequency (SD3.0 DDR)	$f_{PP}$	0	50	MHz
<b>uSDHC Output / Card Inputs SD_CMD, SDx_DATAx (Reference to CLK)</b>					
SD2	uSDHC Output Delay	$t_{OD}$	2.7	6.9	ns
<b>uSDHC Input / Card Outputs SD_CMD, SDx_DATAx (Reference to CLK)</b>					

Table 33. eMMC5.1/SD3.0 (DDR) interface timing specification (continued)

ID	Parameter	Symbols	Min	Max	Unit
SD3	uSDHC Input Setup Time	$t_{ISU}$	2.4	—	ns
SD4	uSDHC Input Hold Time	$t_{IH}$	1.3	—	ns

### 3.9.2.3 HS400 DDR AC timing

Figure 15 depicts the timing of HS400 mode, and Table 34 lists the HS400 timing characteristics. Be aware that only data is sampled on both edges of the clock (not applicable to CMD). The CMD input/output timing for HS400 mode is the same as CMD input/output timing for SDR104 mode. Check SD5, SD6, and SD7 parameters in Table 36 SDR50/SDR104 Interface Timing Specification for CMD input/output timing for HS400 mode.

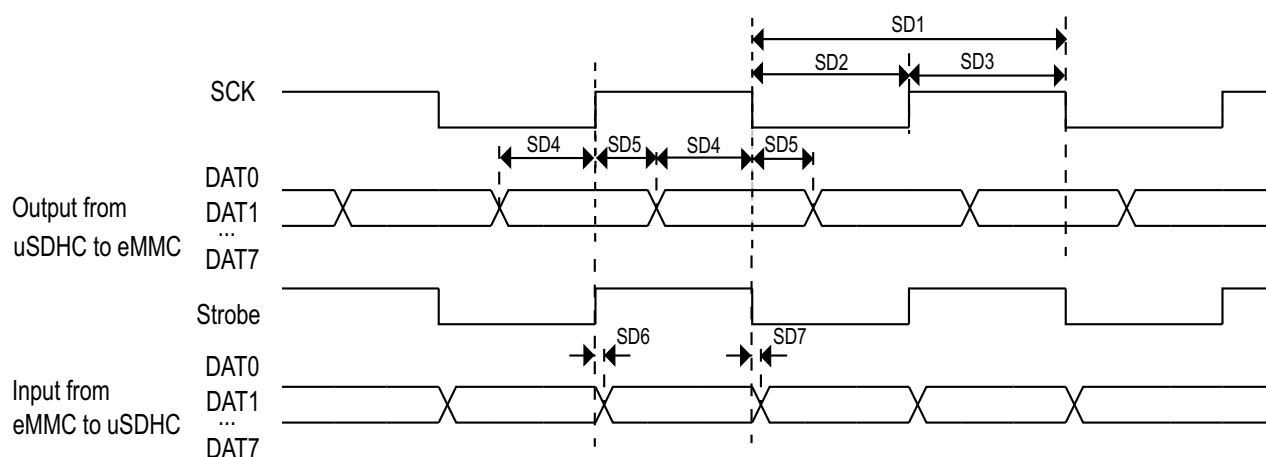

Figure 15. HS400 timing

Table 34. HS400 interface timing specification

ID	Parameter	Symbols	Min	Max	Unit
<b>Card Input Clock</b>					
SD1	Clock frequency	$f_{PP}$	0	200	MHz
SD2	Clock low time	$t_{CL}$	$0.46 \times t_{CLK}$	$0.54 \times t_{CLK}$	ns
SD3	Clock high time	$t_{CH}$	$0.46 \times t_{CLK}$	$0.54 \times t_{CLK}$	ns
<b>uSDHC Output/Card Inputs DAT (Reference to SCK)</b>					
SD4	Output skew from data of edge of SCK	$t_{OSkew1}$	0.45	—	ns
SD5	Output skew from edge of SCK to data	$t_{OSkew2}$	0.45	—	ns
<b>uSDHC Input/Card Outputs DAT (Reference to Strobe)</b>					

## Electrical characteristics

**Table 34. HS400 interface timing specification (continued)**

ID	Parameter	Symbols	Min	Max	Unit
SD6	uSDHC input skew	$t_{RQ}$	—	0.45	ns
SD7	uSDHC hold skew	$t_{RQH}$	—	0.45	ns

### 3.9.2.4 HS200 Mode AC timing

Figure 16 depicts the timing of HS200 mode, and Table 35 lists the HS200 timing characteristics.

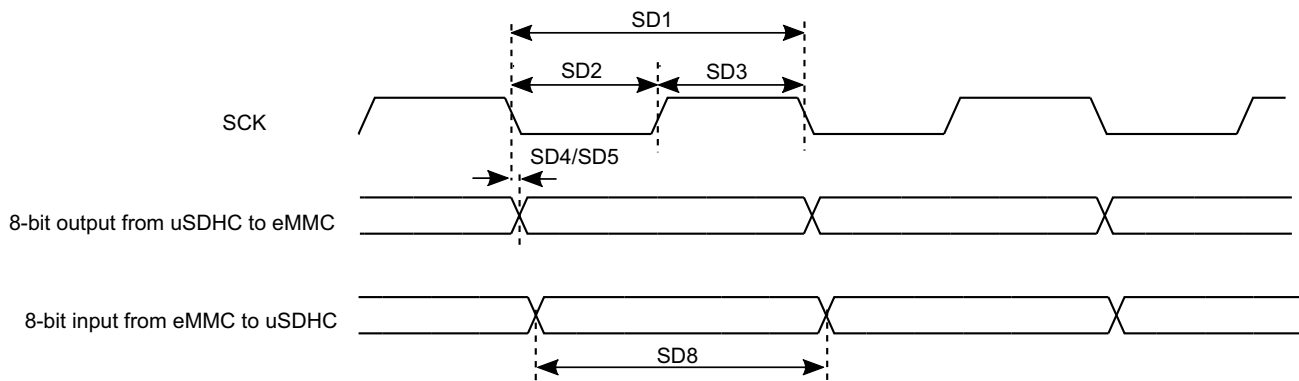

**Figure 16. HS200 timing**

**Table 35. HS200 interface timing specification**

ID	Parameter	Symbols	Min	Max	Unit
<b>Card Input Clock</b>					
SD1	Clock Frequency Period	$t_{CLK}$	5.0	—	ns
SD2	Clock Low Time	$t_{CL}$	$0.3 \times t_{CLK}$	$0.7 \times t_{CLK}$	ns
SD3	Clock High Time	$t_{CH}$	$0.3 \times t_{CLK}$	$0.7 \times t_{CLK}$	ns
<b>uSDHC Output/Card Inputs SD_CMD, SDx_DATAx in HS200 (Reference to CLK)</b>					
SD5	uSDHC Output Delay	$t_{OD}$	-1.6	1	ns
<b>uSDHC Input/Card Outputs SD_CMD, SDx_DATAx in HS200 (Reference to CLK)<sup>1</sup></b>					
SD8	uSDHC Output Data Window	$t_{ODW}$	$0.5 \times t_{CLK}$	—	ns

<sup>1</sup> HS200 is for 8 bits while SDR104 is for 4 bits.

### 3.9.2.5 SDR50/SDR104 AC timing

Figure 17 depicts the timing of SDR50/SDR104, and Table 36 lists the SDR50/SDR104 timing characteristics.

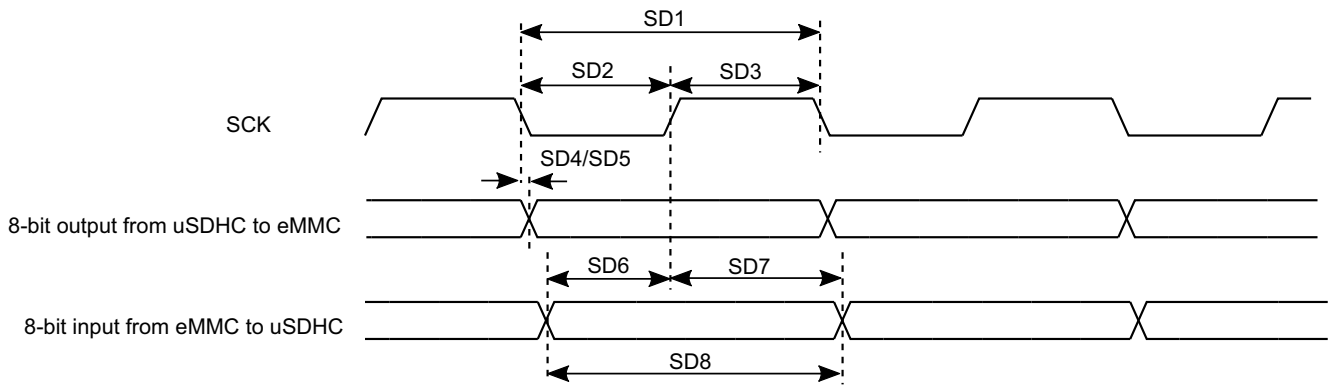

Figure 17. SDR50/SDR104 timing

Table 36. SDR50/SDR104 interface timing specification

ID	Parameter	Symbols	Min	Max	Unit
<b>Card Input Clock</b>					
SD1	Clock Frequency Period	$t_{CLK}$	5	—	ns
SD2	Clock Low Time	$t_{CL}$	$0.46 \times t_{CLK}$	$0.54 \times t_{CLK}$	ns
SD3	Clock High Time	$t_{CH}$	$0.46 \times t_{CLK}$	$0.54 \times t_{CLK}$	ns
<b>uSDHC Output/Card Inputs SD_CMD, SDx_DATAx in SDR50 (Reference to CLK)</b>					
SD4	uSDHC Output Delay	$t_{OD}$	-3	1	ns
<b>uSDHC Output/Card Inputs SD_CMD, SDx_DATAx in SDR104 (Reference to CLK)</b>					
SD5	uSDHC Output Delay	$t_{OD}$	-1.6	1	ns
<b>uSDHC Input/Card Outputs SD_CMD, SDx_DATAx in SDR50 (Reference to CLK)</b>					
SD6	uSDHC Input Setup Time	$t_{ISU}$	2.4	—	ns
SD7	uSDHC Input Hold Time	$t_{IH}$	1.4	—	ns
<b>uSDHC Input/Card Outputs SD_CMD, SDx_DATAx in SDR104 (Reference to CLK)<sup>1</sup></b>					
SD8	uSDHC Output Data Window	$t_{ODW}$	$0.5 \times t_{CLK}$	—	ns

<sup>1</sup> Data window in SDR100 mode is variable.

### 3.9.2.6 Bus operation condition for 3.3 V and 1.8 V signaling

Signaling level of SD/eMMC4.5/5.0/5.1 can be 1.8 V or 3.3 V depending on the working mode. The DC parameters for the NVCC\_SD1, NVCC\_SD2 and NVCC\_SD3 supplies are identical to those shown in Table 22, "GPIO DC parameters," on page 30.

### 3.9.3 Ethernet controller (ENET) AC electrical specifications

The following timing specs are defined at the chip I/O pin and must be translated appropriately to arrive at timing specs/constraints for the physical interface.

**Table 37. ENET signal mapping**

Pad name	Description	Mode	Alt mode	Direction	Comments
ENET_MDC	enet1.MDC	RMII/RGMII	ALT0	O	—
ENET_MDIO	enet1.MDIO	RMII/RGMII	ALT0	I/O	—
ENET_TD3	RGMII.TD3	RGMII	ALT0	O	Only used for RGMII
ENET_TD2	RMII.CLK; RGMII.TD2	RMII/RGMII	ALT0	I/O	Used as RMII clock and RGMII data, there are two RMII clock schemes. <ul style="list-style-type: none"> <li>• MAC generate output 50M reference clock for PHY, and MAC also use this 50M clock.</li> <li>• MAC use external 50M clock.</li> </ul>
ENET_TD1	RMII and RGMII.TD1	RMII/RGMII	ALT0	O	—
ENET_TD0	RMII and RGMII.TD0	RMII/RGMII	ALT0	O	—
ENET_TX_CTL	RMII.TX_EN; RGMII.TX_CTL	RMII/RGMII	ALT0	O	—
ENET_TXC	RMII.TX_ERR; RGMII.TX_CLK	RGMII	ALT0/ALT1	O	For RMII—ENET_TXC works as RMII.TX_ERR need to work in the ALT1 mode. For RGMII—ENET_TXC works as RGMII.TX_CLK need to work in the ALT0 mode.
ENET_RX_CTL	RMII.RX_EN (CRS_DV); RGMII.RC_CTL	RMII/RGMII	ALT0	I	—
ENET_RXC	RMII.RX_ERR; RGMII.RX_CLK	RGMII	ALT0/ALT1	I	For RMII—ENET_RXC works as RMII.RX_ERR need to work in the ALT1 mode. For RGMII—ENET_RXC works as RGMII.RX_CLK need to work in the ALT0 mode.
ENET_RD0	RMII and RGMII.RD0	RMII/RGMII	ALT0	I	—
ENET_RD1	RMII and RGMII.RD1	RMII/RGMII	ALT0	I	—
ENET_RD2	RGMII.RD2	RGMII	ALT0	I	—
ENET_RD3	RGMII.RD3	RGMII	ALT0	I	—
GPIO1_IO06	enet1.MDC	RMII/RGMII	ALT1	O	—
GPIO1_IO07	enet1.MDIO	RMII/RGMII	ALT1	I/O	—
I2C1_SCL	enet1.MDC	RMII/RGMII	ALT1	O	—

Table 37. ENET signal mapping (continued)

Pad name	Description	Mode	Alt mode	Direction	Comments
I2C1_SDA	enet1.MDIO	RMII/RGMII	ALT1	I/O	—
I2C2_SCL	enet1.1588_EV ENT1_IN	RMII/RGMII	ALT1	O	—
I2C2_SDA	enet1.1588_EV ENT1_OUT	RMII/RGMII	ALT1	I/O	—
GPIO1_IO00	ENET_PHY_RE F_CLK_ROOT	RGMII	ALT1	O	Reference clock for PHY.
GPIO1_IO08	enet1.1588_EV ENT0_IN	RMII/RGMII	ALT1	I	Capture/compare block input/output event bus signal. When configured for capture and a rising edge is detected, the current timer value is latched and transferred into the corresponding ENET_TCCRn register for inspection by software. When configured for compare, the corresponding signal 1588_EVENT is asserted for one cycle when the timer reaches the compare value programmed in register ENET_TCCRn. An interrupt or DMA request can be triggered if the corresponding bit in ENET_TCSRn[TIE] or ENET_TCSRn[TDRE] is set.
GPIO1_IO09	enet1.1588_EV ENT0_OUT	RMII/RGMII	ALT1	O	—

### 3.9.3.1 RMII mode timing

Figure 18 shows RMII mode timings. Table 38 describes the timing parameters (M16–M21) shown in the figure.

## Electrical characteristics

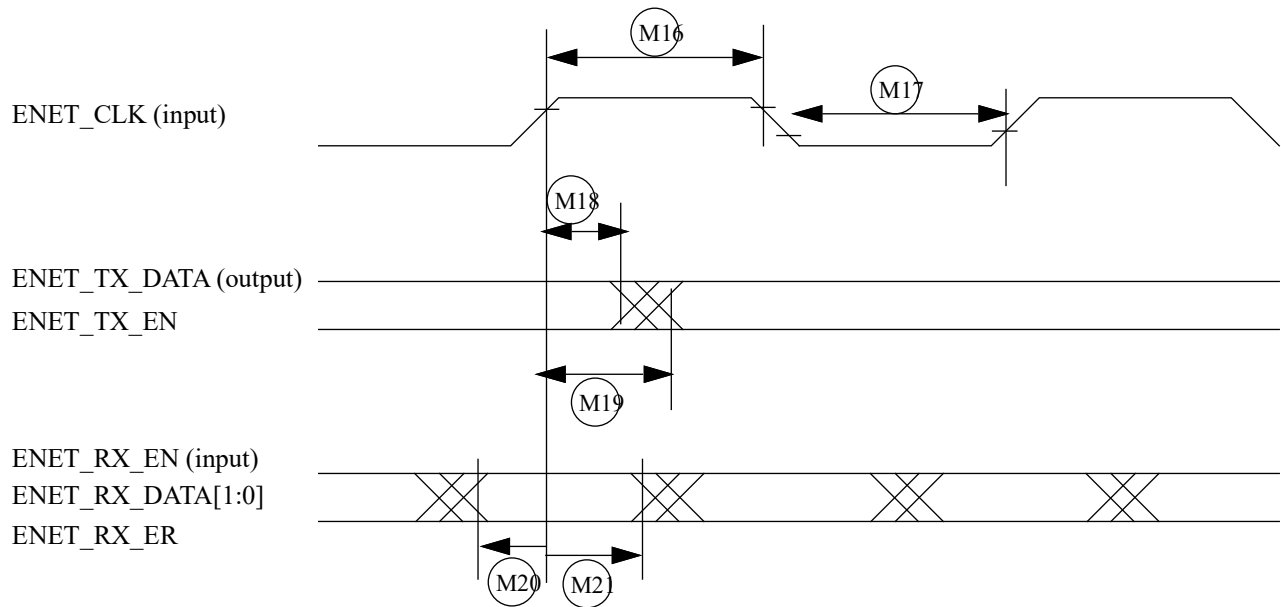

Figure 18. RMI mode signal timing diagram

Table 38. RMI signal timing

ID	Characteristic	Min.	Max.	Unit
M16	ENET_CLK pulse width high	35%	65%	ENET_CLK period
M17	ENET_CLK pulse width low	35%	65%	ENET_CLK period
M18	ENET_CLK to ENET0_TXD[1:0], ENET_TX_DATA invalid	4	—	ns
M19	ENET_CLK to ENET0_TXD[1:0], ENET_TX_DATA valid	—	15	ns
M20	ENET_RX_DATA[1:0], ENET_RX_EN(ENET_RX_EN), ENET_RX_ER to ENET_CLK setup	4	—	ns
M21	ENET_CLK to ENET_RX_DATA[1:0], ENET_RX_EN, ENET_RX_ER hold	2	—	ns

### 3.9.3.2 RGMII signal switching specifications

The following timing specifications meet the requirements for RGMII interfaces for a range of transceiver devices.

Table 39. RGMII signal switching specifications<sup>1</sup>

Symbol	Description	Min.	Max.	Unit
$T_{cyc}^2$	Clock cycle duration	7.2	8.8	ns
$T_{skewT}^3$	Data to clock output skew at transmitter	-500	500	ps

Table 39. RGMII signal switching specifications<sup>1</sup> (continued)

Symbol	Description	Min.	Max.	Unit
$T_{skewR}$ <sup>3</sup>	Data to clock input skew at receiver	1	2.6	ns
Duty_G <sup>4</sup>	Duty cycle for Gigabit	45	55	%
Duty_T <sup>4</sup>	Duty cycle for 10/100T	40	60	%
Tr/Tf	Rise/fall time (20–80%)	—	0.75	ns

<sup>1</sup> The timings assume the following configuration:

DDR\_SEL = (11)b

DSE (drive-strength) = (111)b

<sup>2</sup> For 10 Mbps and 100 Mbps,  $T_{cyc}$  will scale to 400 ns  $\pm$ 40 ns and 40 ns  $\pm$ 4 ns respectively.

<sup>3</sup> For all versions of RGMII prior to 2.0; this implies that PC board design will require clocks to be routed such that an additional trace delay of greater than 1.5 ns and less than 2.0 ns will be added to the associated clock signal. For 10/100, the Max value is unspecified.

<sup>4</sup> Duty cycle may be stretched/shrunk during speed changes or while transitioning to a received packet's clock domain as long as minimum duty cycle is not violated and stretching occurs for no more than three  $T_{cyc}$  of the lowest speed transitioned between.

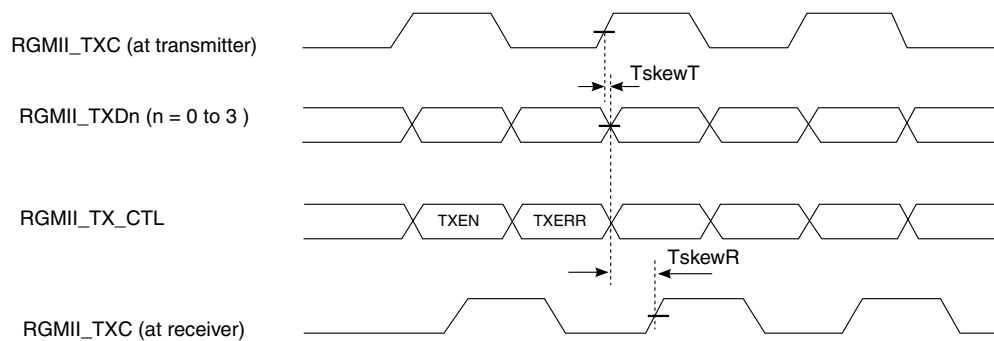

Figure 19. RGMII transmit signal timing diagram original

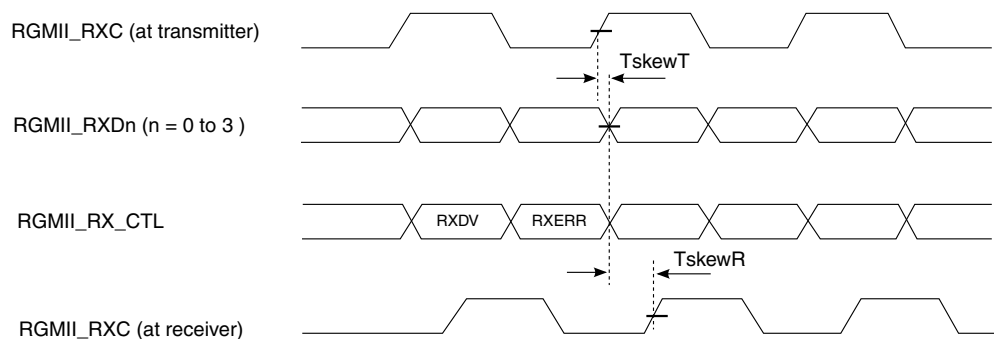

Figure 20. RGMII receive signal timing diagram original

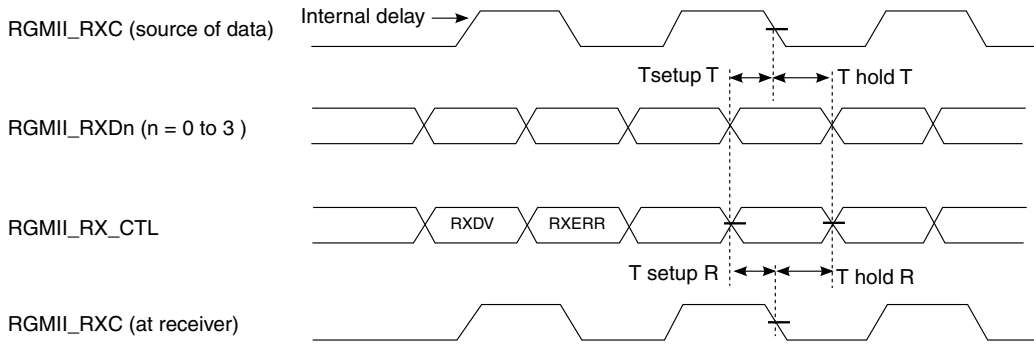

Figure 21. RGMII receive signal timing diagram with internal delay

### 3.9.4 General-purpose media interface (GPMI) timing

The i.MX 8M Mini GPMI controller is a flexible interface NAND Flash controller with 8-bit data width, up to 200 MB/s I/O speed and individual chip select.

It supports Asynchronous Timing mode, Source Synchronous Timing mode and Toggle Timing mode separately, as described in the following subsections.

#### 3.9.4.1 Asynchronous mode AC timing (ONFI 1.0 compatible)

Asynchronous mode AC timings are provided as multiplications of the clock cycle and fixed delay. The maximum I/O speed of GPMI in Asynchronous mode is about 50 MB/s. Figure 22 through Figure 25 depicts the relative timing between GPMI signals at the module level for different operations under Asynchronous mode. Table 40 describes the timing parameters (NF1–NF17) that are shown in the figures.

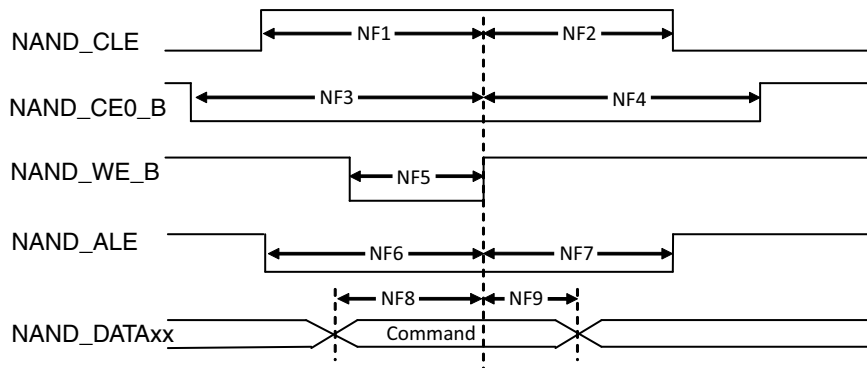

Figure 22. Command Latch cycle timing diagram

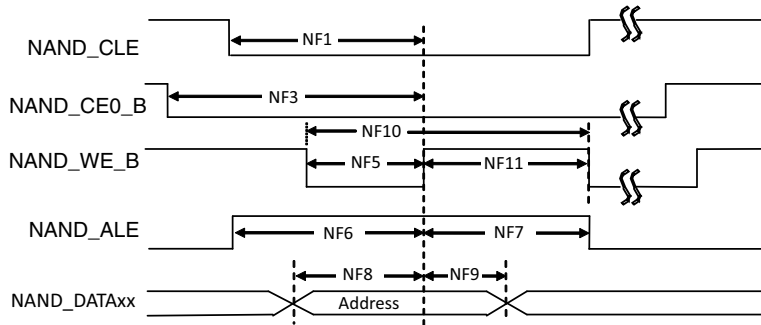

Figure 23. Address Latch cycle timing diagram

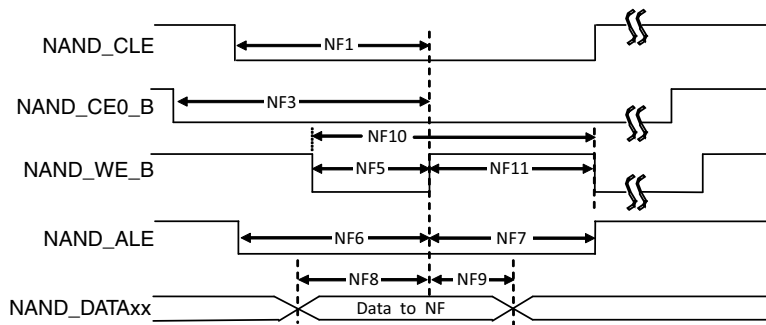

Figure 24. Write Data Latch cycle timing diagram

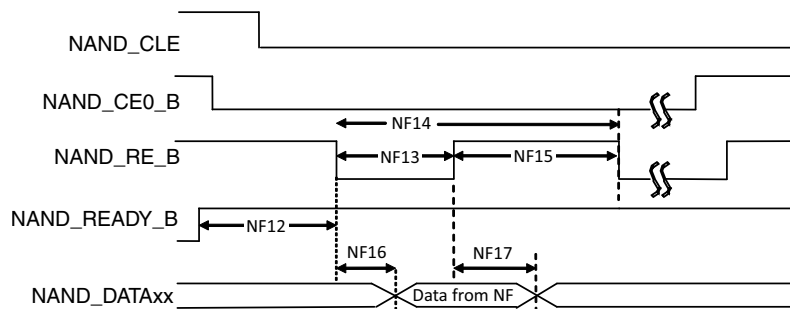

Figure 25. Read Data Latch cycle timing diagram (Non-EDO Mode)

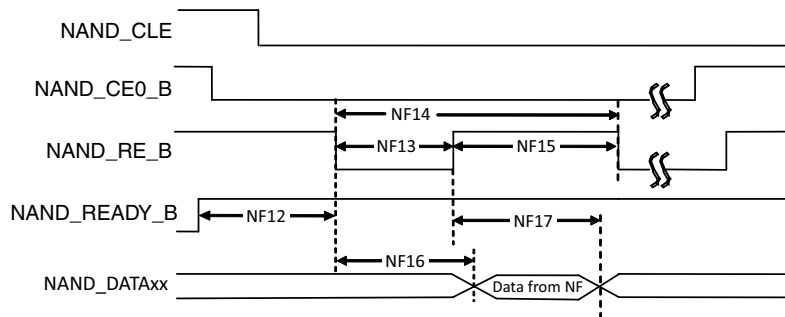

Figure 26. Read Data Latch cycle timing diagram (EDO mode)

Table 40. Asynchronous mode timing parameters<sup>1</sup>

ID	Parameter	Symbol	Timing T = GPMI Clock Cycle		Unit
			Min.	Max.	
NF1	NAND_CLE setup time	tCLS	$(AS + DS) \times T - 0.12$ [see notes <sup>2,3</sup> ]		ns
NF2	NAND_CLE hold time	tCLH	$DH \times T - 0.72$ [see note <sup>2</sup> ]		ns
NF3	NAND_CE0_B setup time	tCS	$(AS + DS + 1) \times T$ [see notes <sup>3,2</sup> ]		ns
NF4	NAND_CE0_B hold time	tCH	$(DH+1) \times T - 1$ [see note <sup>2</sup> ]		ns
NF5	NAND_WE_B pulse width	tWP	$DS \times T$ [see note <sup>2</sup> ]		ns
NF6	NAND_ALE setup time	tALS	$(AS + DS) \times T - 0.49$ [see notes <sup>3,2</sup> ]		ns
NF7	NAND_ALE hold time	tALH	$DH \times T - 0.42$ [see note <sup>2</sup> ]		ns
NF8	Data setup time	tDS	$DS \times T - 0.26$ [see note <sup>2</sup> ]		ns
NF9	Data hold time	tDH	$DH \times T - 1.37$ [see note <sup>2</sup> ]		ns
NF10	Write cycle time	tWC	$(DS + DH) \times T$ [see note <sup>2</sup> ]		ns
NF11	NAND_WE_B hold time	tWH	$DH \times T$ [see note <sup>2</sup> ]		ns
NF12	Ready to NAND_RE_B low	tRR <sup>4</sup>	$(AS + 2) \times T$ [see <sup>3,2</sup> ]	—	ns
NF13	NAND_RE_B pulse width	tRP	$DS \times T$ [see note <sup>2</sup> ]		ns
NF14	READ cycle time	tRC	$(DS + DH) \times T$ [see note <sup>2</sup> ]		ns
NF15	NAND_RE_B high hold time	tREH	$DH \times T$ [see note <sup>2</sup> ]		ns
NF16	Data setup on read	tDSR	—	$(DS \times T - 0.67)/18.38$ [see notes <sup>5,6</sup> ]	ns
NF17	Data hold on read	tDHR	0.82/11.83 [see notes <sup>5,6</sup> ]	—	ns

<sup>1</sup> GPMI's Asynchronous mode output timing can be controlled by the module's internal registers HW\_GPMI\_TIMING0\_ADDRESS\_SETUP, HW\_GPMI\_TIMING0\_DATA\_SETUP, and HW\_GPMI\_TIMING0\_DATA\_HOLD. This AC timing depends on these registers settings. In the table, AS/DS/DH represents each of these settings.

<sup>2</sup> AS minimum value can be 0, while DS/DH minimum value is 1.

<sup>3</sup> T = GPMI clock period -0.075 ns (half of maximum p-p jitter).

<sup>4</sup> NF12 is guaranteed by the design.

<sup>5</sup> Non-EDO mode.

<sup>6</sup> EDO mode, GPMI clock  $\approx$  100 MHz  
(AS=DS=DH=1, GPMI\_CTL1 [RDN\_DELAY] = 8, GPMI\_CTL1 [HALF\_PERIOD] = 0).

In EDO mode (Figure 25), NF16/NF17 are different from the definition in non-EDO mode (Figure 24). They are called tREA/tRHOH (RE# access time/RE# HIGH to output hold). The typical values for them are 16 ns (max for tREA)/15 ns (min for tRHOH) at 50 MB/s EDO mode. In EDO mode, GPMI samples NAND\_DATAxx at the rising edge of delayed NAND\_RE\_B provided by an internal DPLL. The delay value can be controlled by GPMI\_CTRL1.RDN\_DELAY (see the GPMI chapter of the *i.MX 8M Mini Applications Processor Reference Manual* [IMX8MMRM]). The typical value of this control register is 0x8 at 50 MT/s EDO mode. But if the board delay is big enough and cannot be ignored, the delay value should be made larger to compensate the board delay.

### 3.9.4.2 Source synchronous mode AC timing (ONFI 2.x compatible)

Figure 27 to Figure 29 show the write and read timing of Source Synchronous mode.

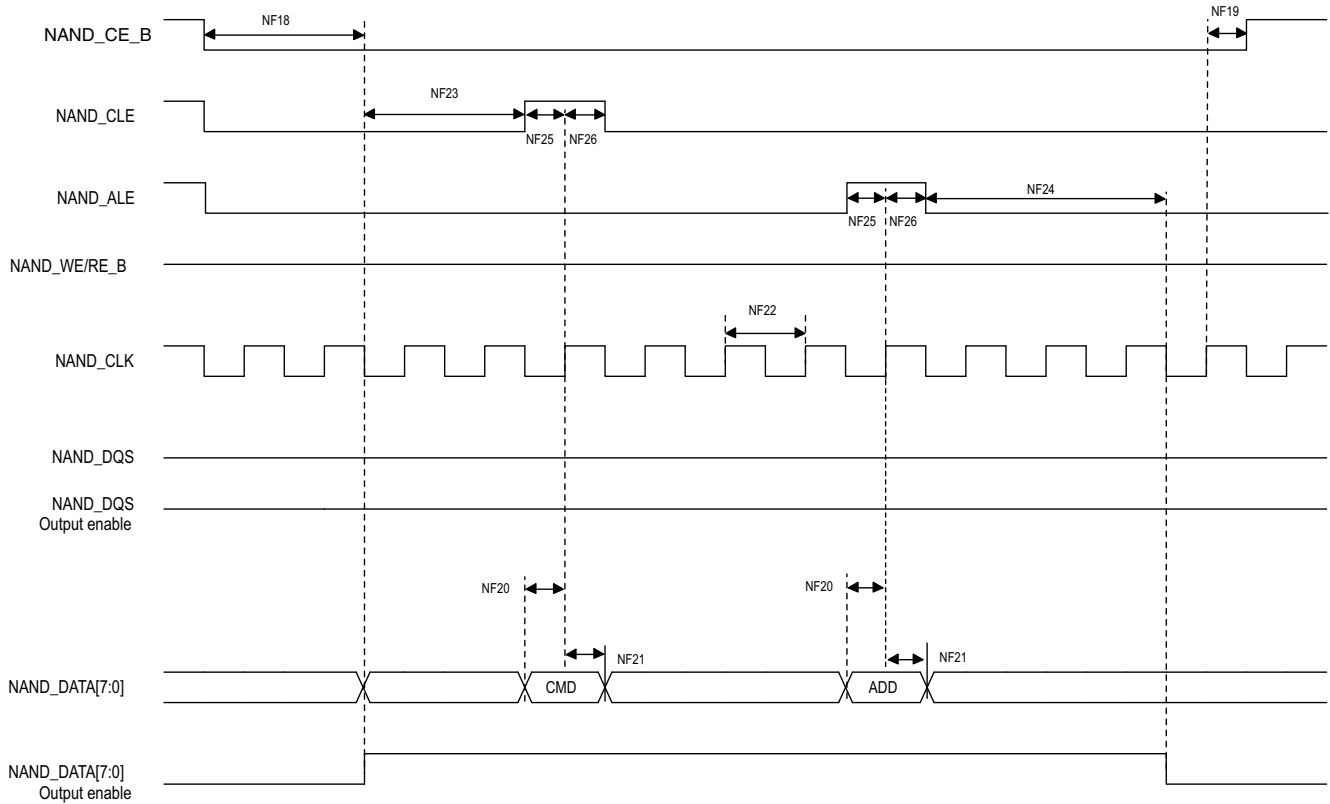
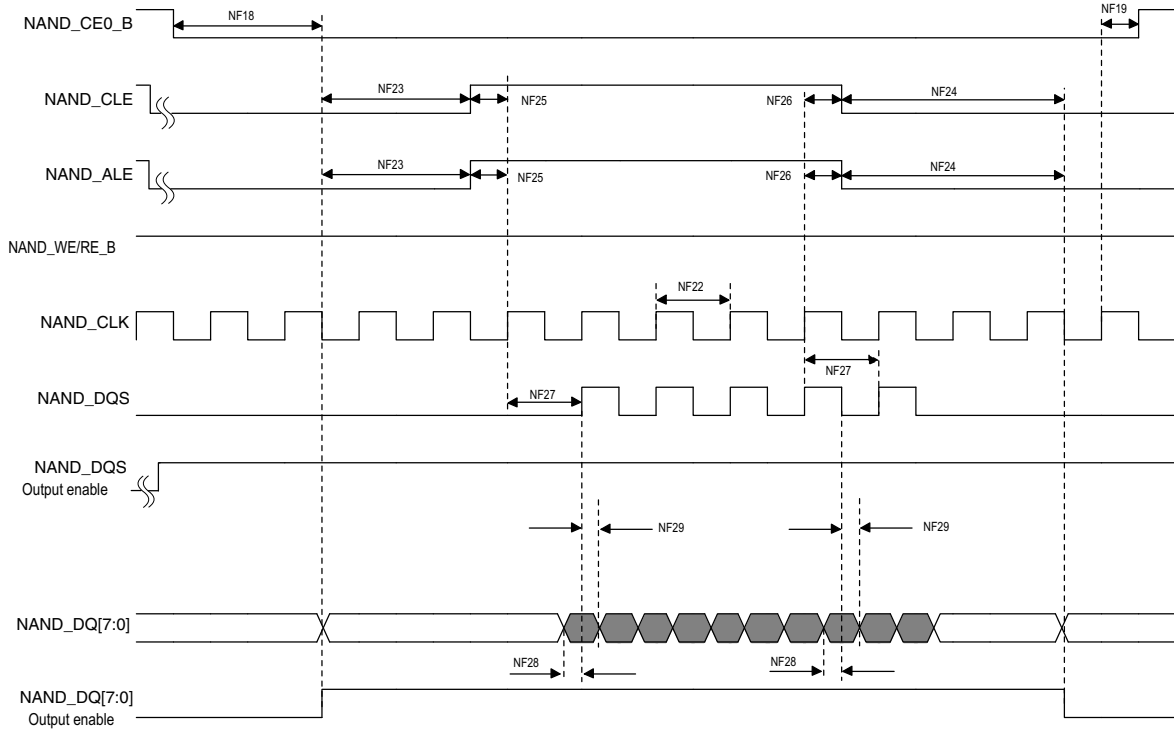
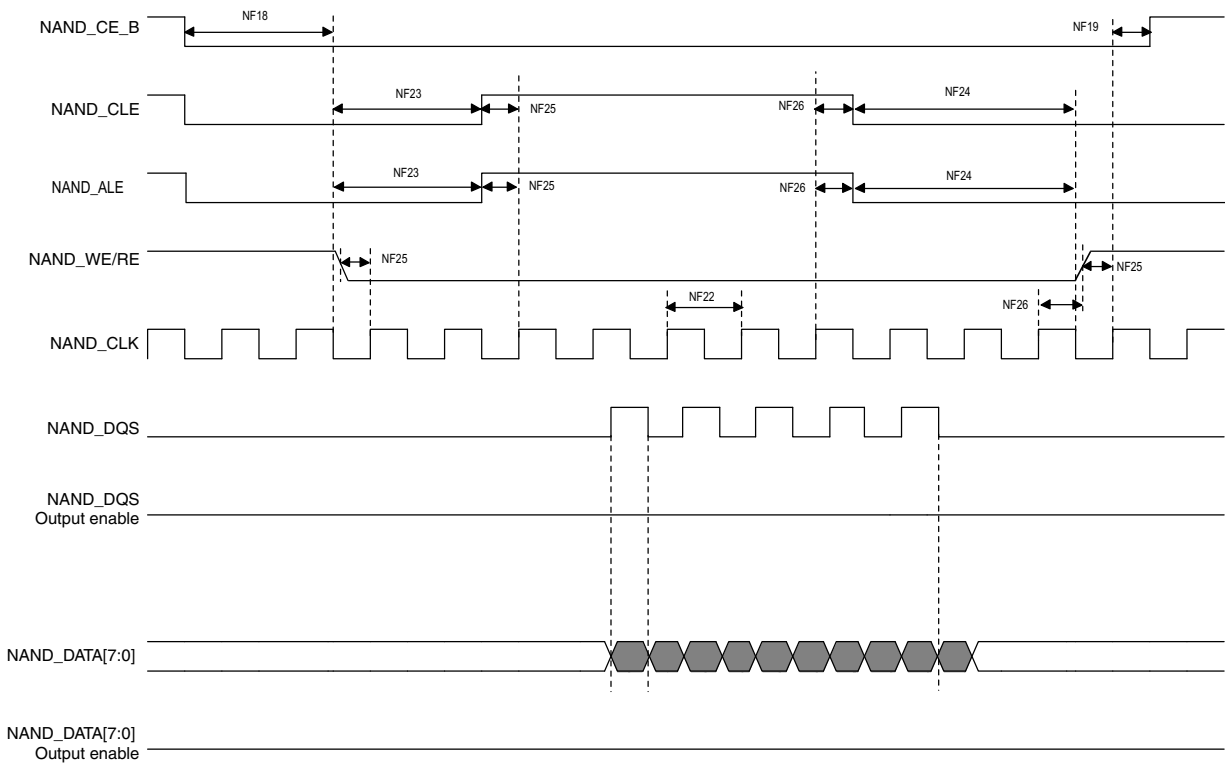

Figure 27. Source Synchronous mode command and address timing diagram

## Electrical characteristics



**Figure 28. Source Synchronous mode data write timing diagram**



**Figure 29. Source Synchronous mode data read timing diagram**

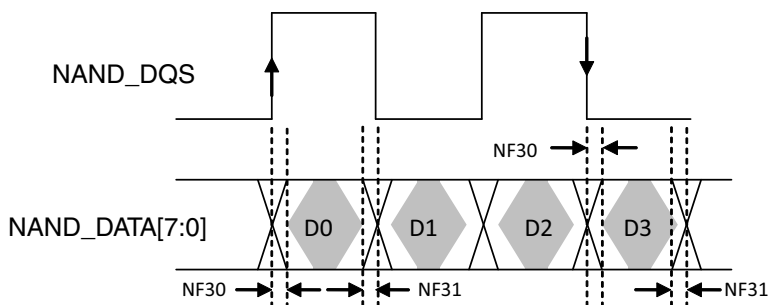

Figure 30. NAND\_DQS/NAND\_DQ read valid window

Table 41. Source Synchronous mode timing parameters<sup>1</sup>

ID	Parameter	Symbol	Timing T = GPMI Clock Cycle		Unit
			Min.	Max.	
NF18	NAND_CEO_B access time	tCE	CE_DELAY × T - 0.79 [see note <sup>2</sup> ]		ns
NF19	NAND_CEO_B hold time	tCH	0.5 × tCK - 0.63 [see note <sup>2</sup> ]		ns
NF20	Command/address NAND_DATAxx setup time	tCAS	0.5 × tCK - 0.05		ns
NF21	Command/address NAND_DATAxx hold time	tCAH	0.5 × tCK - 1.23		ns
NF22	clock period	tCK	—		ns
NF23	preamble delay	tPRE	PRE_DELAY × T - 0.29 [see note <sup>2</sup> ]		ns
NF24	postamble delay	tPOST	POST_DELAY × T - 0.78 [see note <sup>2</sup> ]		ns
NF25	NAND_CLE and NAND_ALE setup time	tCALS	0.5 × tCK - 0.86		ns
NF26	NAND_CLE and NAND_ALE hold time	tCALH	0.5 × tCK - 0.37		ns
NF27	NAND_CLK to first NAND_DQS latching transition	tDQSS	T - 0.41 [see note <sup>2</sup> ]		ns
NF28	Data write setup	—	0.25 × tCK - 0.35		
NF29	Data write hold	—	0.25 × tCK - 0.85		
NF30	NAND_DQS/NAND_DQ read setup skew	—	—	2.06	
NF31	NAND_DQS/NAND_DQ read hold skew	—	—	1.95	

<sup>1</sup> GPMI's Source Synchronous mode output timing can be controlled by the module's internal registers GPMI\_TIMING2\_CE\_DELAY, GPMI\_TIMING2\_PREAMBLE\_DELAY, GPMI\_TIMING2\_POST\_DELAY. This AC timing depends on these registers settings. In the table, CE\_DELAY/PRE\_DELAY/POST\_DELAY represents each of these settings.

<sup>2</sup> T = tCK(GPMI clock period) - 0.075 ns (half of maximum p-p jitter).

For DDR Source Synchronous mode, Figure 30 shows the timing diagram of NAND\_DQS/NAND\_DATAxx read valid window. The typical value of tDQSQ is 0.85 ns (max) and 1 ns (max) for tQHS at 200 MB/s. GPMI will sample NAND\_DATA[7:0] at both rising and falling edge of an delayed NAND\_DQS signal, which can be provided by an internal DPLL. The delay value can be controlled by GPMI register GPMI\_READ\_DDR\_DLL\_CTRL.SLV\_DLY\_TARGET (see the GPMI chapter of the *i.MX 8M Mini Applications Processor Reference Manual [IMX8MMRM]*). Generally, the typical delay value of this register is equal to 0x7 which means 1/4 clock cycle delay expected. But if the board delay is big enough and cannot be ignored, the delay value should be made larger to compensate the board delay.

### 3.9.4.3 ONFI NV-DDR2 mode (ONFI 3.2 compatible)

#### 3.9.4.3.1 Command and address timing

ONFI 3.2 mode command and address timing is the same as ONFI 1.0 compatible Async mode AC timing. See [Section 3.9.4.1, Asynchronous mode AC timing \(ONFI 1.0 compatible\)](#),” for details.

#### 3.9.4.3.2 Read and write timing

ONFI 3.2 mode read and write timing is the same as Toggle mode AC timing. See [Section 3.9.4.4, Toggle mode AC Timing](#),” for details.

### 3.9.4.4 Toggle mode AC Timing

#### 3.9.4.4.1 Command and address timing

**NOTE**

Toggle mode command and address timing is the same as ONFI 1.0 compatible Asynchronous mode AC timing. See [Section 3.9.4.1, Asynchronous mode AC timing \(ONFI 1.0 compatible\)](#),” for details.

#### 3.9.4.4.2 Read and write timing

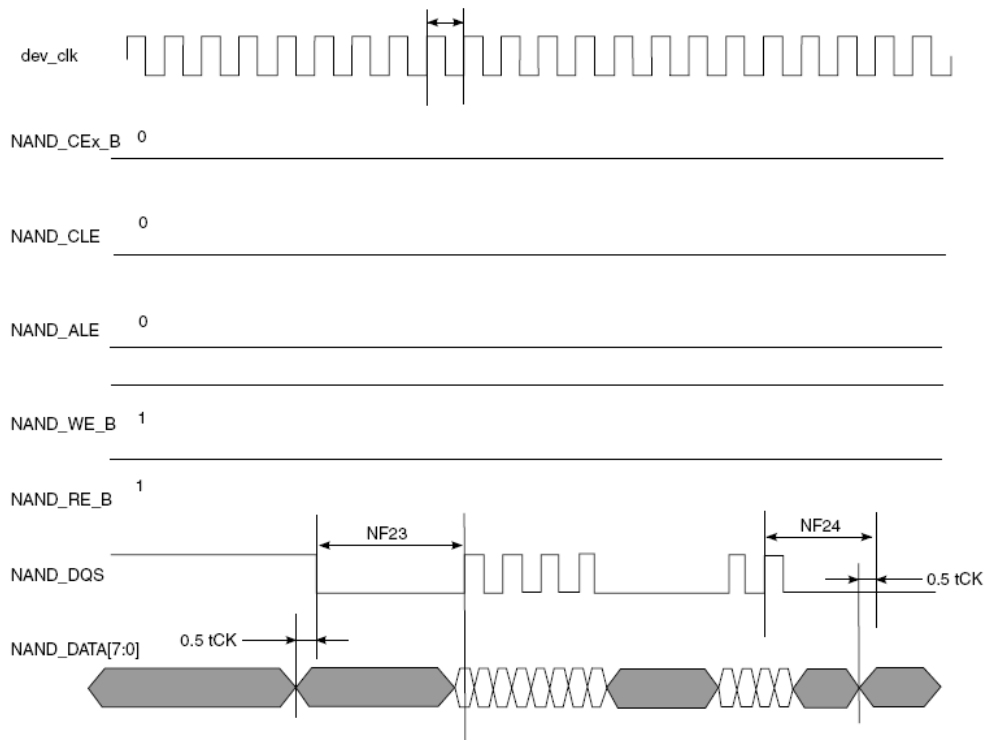

Figure 31. Toggle mode data write timing

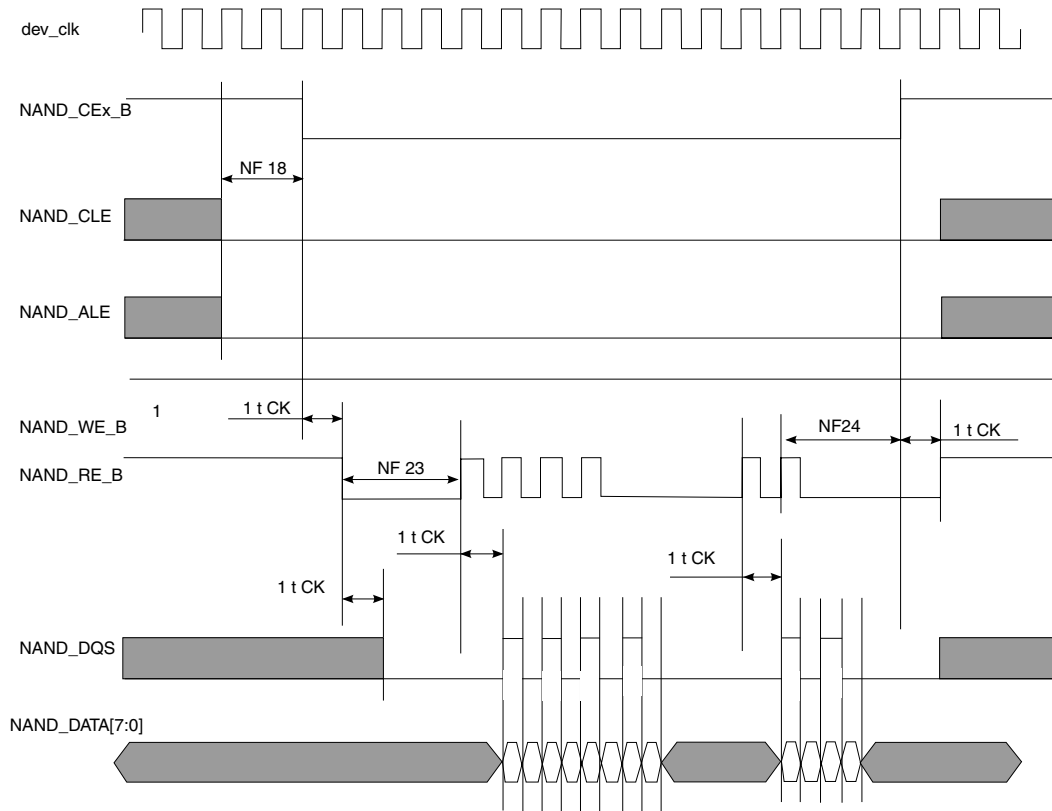

Figure 32. Toggle mode data read timing

Table 42. Toggle mode timing parameters

ID	Parameter	Symbol	Timing T = GPMI Clock Cycle		Unit
			Min.	Max.	
NF1	NAND_CLE setup time	tCLS	$(AS + DS) \times T - 0.12$ [see note <sup>1,2</sup> ]		
NF2	NAND_CLE hold time	tCLH	$DH \times T - 0.72$ [see note <sup>2</sup> ]		
NF3	NAND_CE0_B setup time	tCS	$(AS + DS) \times T - 0.58$ [see notes <sup>2</sup> ]		
NF4	NAND_CE0_B hold time	tCH	$DH \times T - 1$ [see note <sup>2</sup> ]		
NF5	NAND_WE_B pulse width	tWP	$DS \times T$ [see note <sup>2</sup> ]		
NF6	NAND_ALE setup time	tALS	$(AS + DS) \times T - 0.49$ [see notes <sup>2</sup> ]		
NF7	NAND_ALE hold time	tALH	$DH \times T - 0.42$ [see note <sup>2</sup> ]		
NF8	Command/address NAND_DATAxx setup time	tCAS	$DS \times T - 0.26$ [see note <sup>2</sup> ]		
NF9	Command/address NAND_DATAxx hold time	tCAH	$DH \times T - 1.37$ [see note <sup>2</sup> ]		
NF18	NAND_CEx_B access time	tCE	$CE\_DELAY \times T$ [see notes <sup>3,2</sup> ]	—	ns
NF22	clock period	tCK	—	—	ns
NF23	preamble delay	tPRE	$PRE\_DELAY \times T$ [see notes <sup>4,2</sup> ]	—	ns

Table 42. Toggle mode timing parameters (continued)

ID	Parameter	Symbol	Timing T = GPMI Clock Cycle		Unit
			Min.	Max.	
NF24	postamble delay	tPOST	POST_DELAY × T + 0.43 [see note <sup>2</sup> ]	—	ns
NF28	Data write setup	tDS <sup>5</sup>	0.25 × tCK - 0.32	—	ns
NF29	Data write hold	tDH <sup>5</sup>	0.25 × tCK - 0.79	—	ns
NF30	NAND_DQS/NAND_DQ read setup skew	tDQSQ <sup>6</sup>	—	3.18	ns
NF31	NAND_DQS/NAND_DQ read hold skew	tQHS <sup>6</sup>	—	3.27	ns

<sup>1</sup> AS minimum value can be 0, while DS/DH minimum value is 1.

<sup>2</sup> T = tCK (GPMI clock period) - 0.075 ns (half of maximum p-p jitter).

<sup>3</sup> CE\_DELAY represents HW\_GPMI\_TIMING2[CE\_DELAY]. NF18 is guaranteed by the design. Read/Write operation is started with enough time of ALE/CLE assertion to low level.

<sup>4</sup> PRE\_DELAY+1 ≥ (AS+DS)

<sup>5</sup> Shown in Figure 31.

<sup>6</sup> Shown in Figure 32.

For DDR Toggle mode, Figure 30 shows the timing diagram of NAND\_DQS/NAND\_DATA<sub>xx</sub> read valid window. The typical value of tDQSQ is 1.4 ns (max) and 1.4 ns (max) for tQHS at 133 MB/s. GPMI samples NAND\_DATA[7:0] at both the rising and falling edges of a delayed NAND\_DQS signal, which is provided by an internal DPLL. The delay value of this register can be controlled by the GPMI register GPMI\_READ\_DDR\_DLL\_CTRL.SLV\_DLY\_TARGET (see the GPMI chapter of the *i.MX 8M Mini Applications Processor Reference Manual* [IMX8MMRM]). Generally, the typical delay value is equal to 0x7, which means a 1/4 clock cycle delay is expected. But if the board delay is big enough and cannot be ignored, the delay value should be made larger to compensate the board delay.

### 3.9.5 I<sup>2</sup>C bus characteristics

The Inter-Integrated Circuit (I2C) provides functionality of a standard I2C master and slave. The I2C is designed to be compatible with the I2C Bus Specification, version 2.1, by Philips Semiconductor (now NXP Semiconductors).

### 3.9.6 MIPI D-PHY timing parameters

MIPI D-PHY electrical specifications are compliance.

Table 43. MIPI PHY worst power dissipation<sup>1</sup>

MODE		Power consume on VDD_MIPI_0P9 (mW)	Power consume on VDD_MIPI_1P2 (mW)	Power consume on VDD_MIPI_1P8 (mW)	Total power consume (mW)
2.1 Gbps	M4 on S4 on	226.1	4.1	35.6	265.8
	M4 on S4 off	164.7	4.03	28.6	197.33
	M4 off S4 on	63.02	0	15.8	78.82
ULPS		4.26	0.0367	0.0584	4.36

<sup>1</sup> M4 indicates MIPI DSI have 4 data lane enable (at least 1 clock lane enable). S4 indicates MIPI CSI have 4 data lane enable (at least 1 clock lane enable).

### 3.9.7 PCIe PHY parameters

The PCIe interface is designed to be compatible with PCIe specification Gen2 x1 lane and supports the PCI Express 1.1/2.0 standard.

Table 44. PCIe DC electrical characteristics

Parameter	Description	Min	Typ	Max	Unit	
PD	Power Consumption	Normal Gen2	—	129.5	—	mW
		Partial Mode	—	98.2	—	mW
		Slumber Mode	—	4.9	—	mW
		Full Powerdown	—	0.1	—	mW

#### 3.9.7.1 PCIE\_RESREF reference resistor connection

The impedance calibration process requires connection of reference resistor 8.2 k $\Omega$ . 1% precision resistor on PCIE\_RESREF pads to ground. It is used for termination impedance calibration.

### 3.9.8 PDM timing parameters

Figure 33 illustrates the input timing of the PDM.

## Electrical characteristics

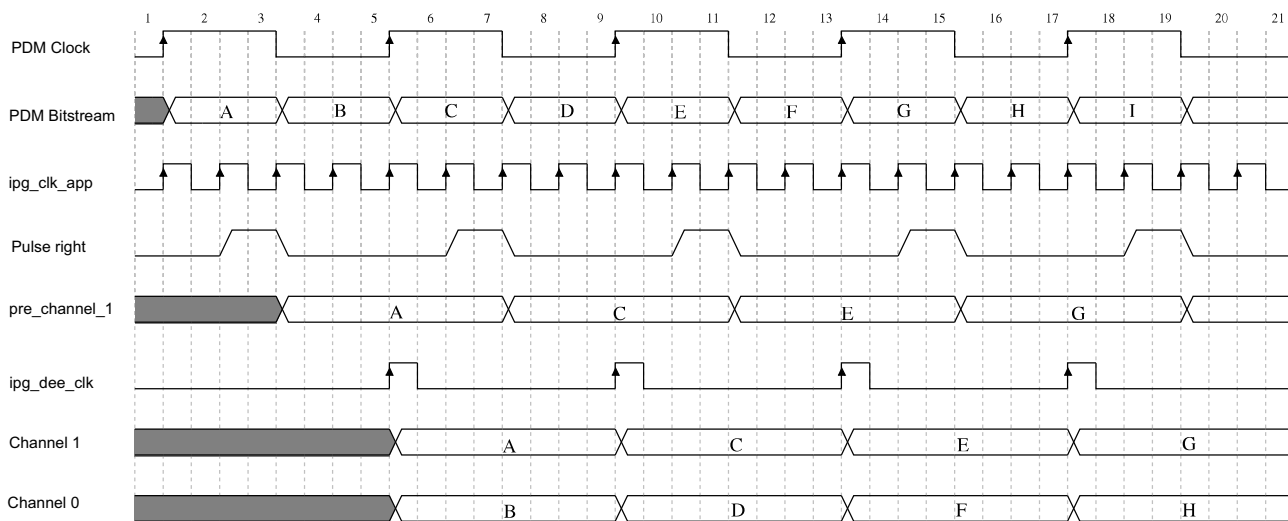

**Figure 33. PDM input timing**

PDM clock operative range is from 500 kHz to 6 MHz. Within range, only need to configure ipg\_clk\_app rate and CLKDIV without I/O timing concerns.

### 3.9.9 Pulse width modulator (PWM) timing parameters

This section describes the electrical information of the PWM. The PWM can be programmed to select one of three clock signals as its source frequency. The selected clock signal is passed through a prescaler before being input to the counter. The output is available at the pulse-width modulator output (PWMO) external pin.

Figure 34 depicts the timing of the PWM, and Table 45 lists the PWM timing parameters.

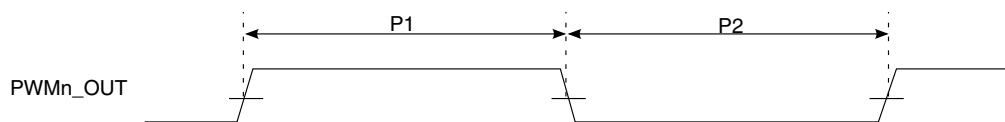

**Figure 34. PWM timing**

**Table 45. PWM output timing parameters**

ID	Parameter	Min	Max	Unit
	PWM Module Clock Frequency	0	66 (ipg_clk)	MHz
P1	PWM output pulse width high	12	—	ns
P2	PWM output pulse width low	12	—	ns

### 3.9.10 FlexSPI timing parameters

Measurements are with a load of 15 pF and an input slew rate of 1 V/ns.

#### 3.9.10.1 FlexSPI input/read timing

There are three sources for the internal sample clock for FlexSPI read data:

- Dummy read strobe generated by FlexSPI controller and looped back internally (FlexSPI<sub>n</sub>\_MCR0[RXCLKSRC] = 0x0)
- Dummy read strobe generated by FlexSPI controller and looped back through the DQS pad (FlexSPI<sub>n</sub>\_MCR0[RXCLKSRC] = 0x1)
- Read strobe provided by memory device and input from DQS pad (FlexSPI<sub>n</sub>\_MCR0[RXCLKSRC] = 0x3)

The following sections describe input signal timing for each of these four internal sample clock sources.

##### 3.9.10.1.1 SDR mode with FlexSPI<sub>n</sub>\_MCR0[RXCLKSRC] = 0x0, 0x1

**Table 46. FlexSPI input timing in SDR mode where FlexSPI<sub>n</sub>\_MCR0[RXCLKSRC] = 0x0**

Symbol	Parameter	Min.	Max.	Unit	Notes
—	[D:] Frequency of operation	—	66	MHz	—
F1	[D:] Setup time for incoming data	8.67	—	ns	1
F2	[D:] Hold time for incoming data	0	—	ns	—

<sup>1</sup> The setup specification here assumes the data learning feature is not used. If data learning is enabled, then TIS can be decreased by up to 2ns.

**Table 47. FlexSPI input timing in SDR mode where FlexSPI<sub>n</sub>\_MCR0[RXCLKSRC] = 0x1**

Symbol	Parameter	Min.	Max.	Unit	Notes
—	[D:] Frequency of operation	—	133	MHz	—
F1	[D:] Setup time for incoming data	1.5	—	ns	1
F2	[D:] Hold time for incoming data	1	—	ns	—

<sup>1</sup> The setup specification here assumes the data learning feature is not used. If data learning is enabled, then TIS can be decreased by up to 2ns.

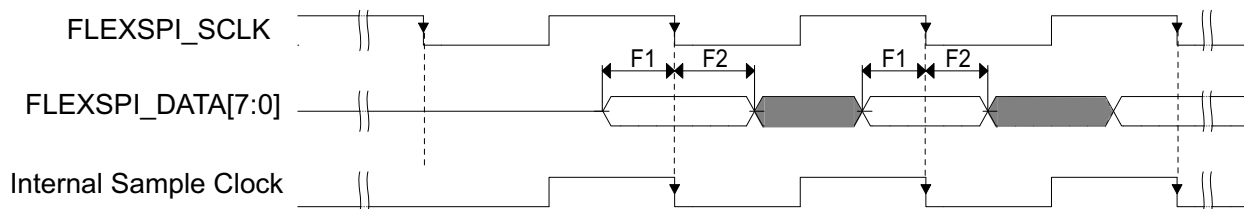

**Figure 35. FlexSPI input timing in SDR mode where FlexSPI<sub>n</sub>\_MCR0[RXCLKSRC] = 0x0, 0x1**

**NOTE**

Timing shown is based on the memory generating read data on the SCK falling edge, and FlexSPI controller sampling read data on the falling edge.

**3.9.10.1.2 SDR mode with FlexSPIn\_MCR0[RXCLKSRC] = 0x3**

There are two cases when the memory provides both read data and the read strobe in SDR mode:

- A1—Memory generates both read data and read strobe on SCK rising edge (or falling edge)
- A2—Memory generates read data on SCK falling edge and generates read strobe on SCK rising edge

**Table 48. FlexSPI input timing in SDR mode where FlexSPIn\_MCR0[RXCLKSRC] = 0x3 (Case A1)**

Symbol	Parameter	Min.	Max.	Unit
—	[D:] Frequency of operation	—	166	MHz
F3	[D:] Time from SCK to data valid	—	—	ns
F4	[D:] Time from SCK to DQS	—	—	ns
—	[D:] Time delta between TSCKD and TSCKDQS	-2	2	ns

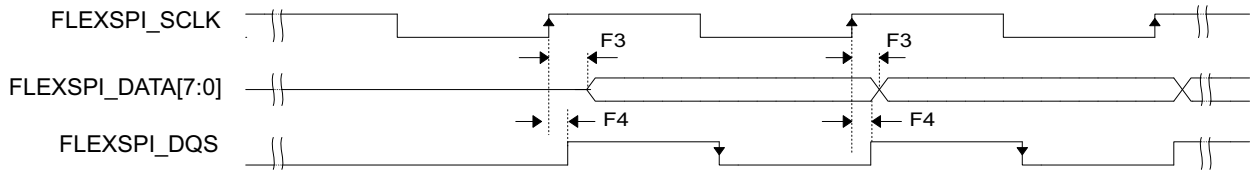

**Figure 36. FlexSPI input timing in SDR mode where FlexSPIn\_MCR0[RXCLKSRC] = 0x3 (Case A1)**

**NOTE**

Timing shown is based on the memory generating read data and read strobe on the SCK rising edge. The FlexSPI controller samples read data on the DQS falling edge.

**Table 49. FlexSPI input timing in SDR mode where FlexSPIn\_MCR0[RXCLKSRC] = 0x3 (Case A2)**

Symbol	Parameter	Min.	Max.	Unit
—	[D:] Frequency of operation	—	166	MHz
F5	[D:] Time from SCK to data valid	—	—	ns
F6	[D:] Time from SCK to DQS	—	—	ns
—	[D:] Time delta between TSCKD and TSCKDQS	-2	2	ns

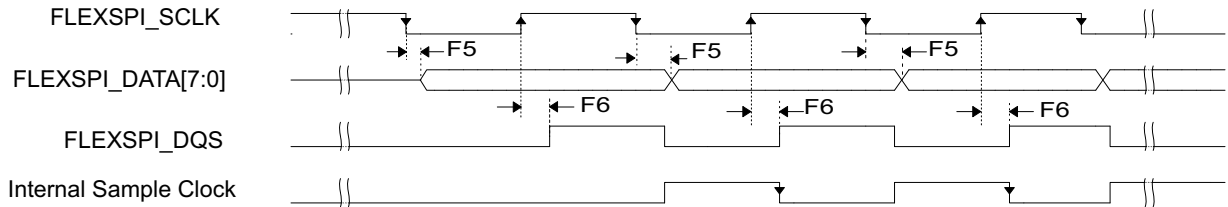

Figure 37. FlexSPI input timing in SDR mode where FlexSPIn\_MCR0[RXCLKSRC] = 0x3 (Case A2)

#### NOTE

Timing shown is based on the memory generating read data on the SCK falling edge and read strobe on the SCK rising edge. The FlexSPI controller samples read data on a half-cycle delayed DQS falling edge.

#### 3.9.10.1.3 DDR mode with FlexSPIn\_MCR0[RXCLKSRC] = 0x0, 0x1

Table 50. FlexSPI input timing in DDR mode where FlexSPIn\_MCR0[RXCLKSRC] = 0x0

Symbol	Parameter	Min.	Max.	Unit	Notes
—	[D:] Frequency of operation	—	33	MHz	—
F1	[D:] Setup time for incoming data	8.67	—	ns	1
F2	[D:] Hold time for incoming data	0	—	ns	—

<sup>1</sup> The setup specification here assumes the data learning feature is not used. If data learning is enabled, then TIS can be decreased by up to 2ns.

Table 51. FlexSPI input timing in DDR mode where FlexSPIn\_MCR0[RXCLKSRC] = 0x1

Symbol	Parameter	Min.	Max.	Unit	Notes
—	[D:] Frequency of operation	—	66	MHz	—
F1	[D:] Setup time for incoming data	1.5	—	ns	1
F2	[D:] Hold time for incoming data	1	—	ns	—

<sup>1</sup> The setup specification here assumes the data learning feature is not used. If data learning is enabled, then TIS can be decreased by up to 2ns.

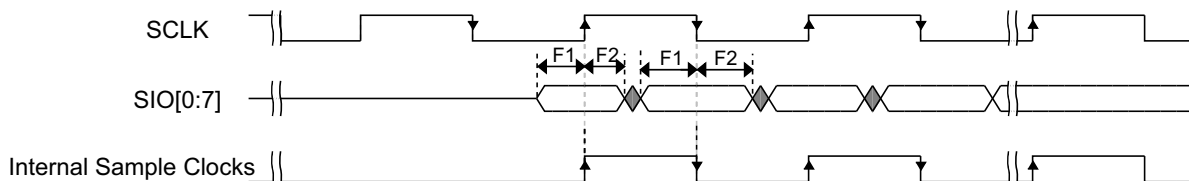

Figure 38. FlexSPI input timing in DDR mode where FlexSPIn\_MCR0[RXCLKSRC] = 0x0, 0x1

### 3.9.10.1.4 DDR mode with FlexSPI<sub>n</sub>\_MCR0[RXCLKSRC] = 0x3

Table 52. FlexSPI input timing in DDR mode where FlexSPI<sub>n</sub>\_MCR0[RXCLKSRC] = 0x3 (Case 1)

Symbol	Parameter	Min.	Max.	Unit
—	[D:] Frequency of operation	—	166	MHz
T <sub>SCKD</sub>	[D:] Time from SCK to data valid	—	—	ns
T <sub>SCKDQS</sub>	[D:] Time from SCK to DQS	—	—	ns
T <sub>SCKD</sub> - T <sub>SCKDQS</sub>	[D:] Time delta between T <sub>SCKD</sub> and T <sub>SCKDQS</sub>	-0.6	0.6	ns

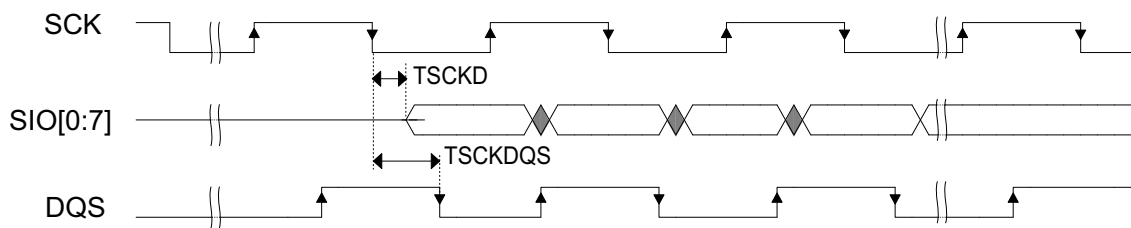

Figure 39. FlexSPI input timing in DDR mode where FlexSPI<sub>n</sub>\_MCR0[RXCLKSRC] = 0x3

### 3.9.10.2 FlexSPI output/write timing

The following sections describe output signal timing for the FlexSPI controller including control signals and data outputs.

#### 3.9.10.2.1 SDR mode

Table 53. FlexSPI output timing in SDR mode

Symbol	Parameter	Min.	Max.	Unit
—	[D:] Frequency of operation <sup>1</sup>	—	166	MHz
T <sub>CK</sub>	[D:] SCK clock period	6.02	—	ns
T <sub>D<sub>SO</sub></sub>	[D:] Output data setup time	2	—	ns
T <sub>D<sub>HO</sub></sub>	[D:] Output data hold time	2	—	ns
T <sub>C<sub>SS</sub></sub>	[D:] Chip select output setup time	3 x T <sub>CK</sub> - 1	—	ns
T <sub>C<sub>SH</sub></sub>	[D:] Chip select output hold time	3 x T <sub>CK</sub> - 1	—	ns

<sup>1</sup> The actual maximum frequency supported is limited by the FlexSPI<sub>n</sub>\_MCR0[RXCLKSRC] configuration used. See the FlexSPI SDR input timing specifications.

### NOTE

$T_{CSS}$  and  $T_{CSH}$  are configured by the FlexSPI<sub>n</sub>\_FLSHAxCR1 register, the default values are shown above. See the *i.MX 8M Mini Applications Processor Reference Manual (IMX8MMRM)* for more details.

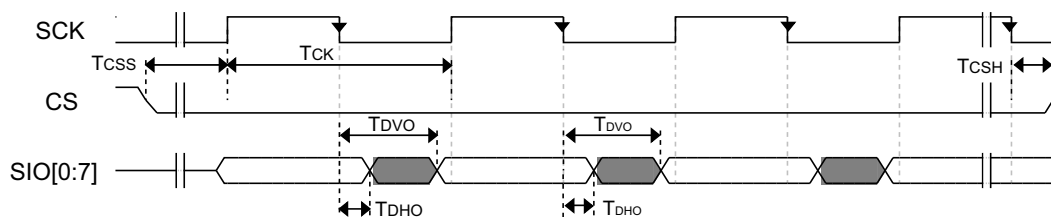

Figure 40. FlexSPI output timing in SDR mode

### 3.9.10.2.2 DDR mode

Table 54. FlexSPI output timing in DDR mode

Symbol	Parameter	Min.	Max.	Unit
—	[D:] Frequency of operation <sup>1</sup>	—	166	MHz
$T_{CK}$	[D:] SCK clock period	6.02	—	ns
$T_{DSO}$	[D:] Output data setup time	—	0.6	ns
$T_{DHO}$	[D:] Output data hold time	0.6	—	ns
$T_{CSS}$	[D:] Chip select output setup time	$3 \times T_{CK} - 1.075$	—	ns
$T_{CSH}$	[D:] Chip select output hold time	$3 \times T_{CK} - 1.075$	—	ns

<sup>1</sup> The actual maximum frequency supported is limited by the FlexSPI<sub>n</sub>\_MCR0[RXCLKSRC] configuration used. See the FlexSPI SDR input timing specifications.

### NOTE

$T_{CSS}$  and  $T_{CSH}$  are configured by the FlexSPI<sub>n</sub>\_FLSHAxCR1 register, the default values are shown above. See the *i.MX 8M Mini Applications Processor Reference Manual (IMX8MMRM)* for more details.

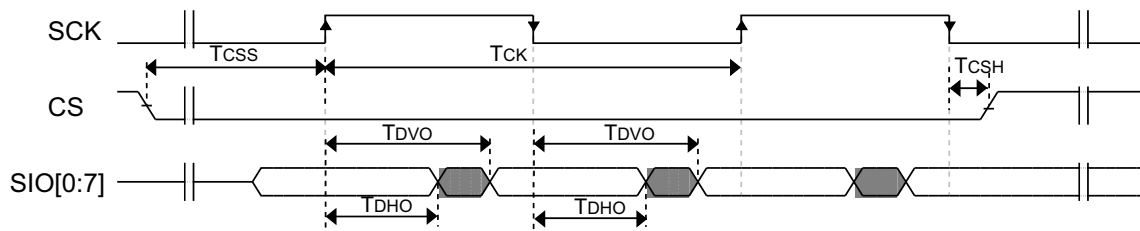

Figure 41. FlexSPI output timing in DDR mode

### 3.9.11 SAI/I2S switching specifications

This section provides the AC timings for the SAI in Master (clocks driven) and Slave (clocks input) modes. All timings are given for non inverted serial clock polarity (SAI\_TCR[TSCKP] = 0, SAI\_RCR[RSCKP] = 0) and non inverted frame sync (SAI\_TCR[TFSI] = 0, SAI\_RCR[RFSI] = 0). If the polarity of the clock and/or the frame sync have been inverted, all the timings remain valid by inverting the clock signal (SAI\_BCLK) and/or the frame sync (SAI\_FS) shown in the figures below.

Table 55. Master mode SAI timing (50 MHz)<sup>1</sup>

Num	Characteristic	Min	Max	Unit
S1	SAI_MCLK cycle time	20	—	ns
S2	SAI_MCLK pulse width high/low	40%	60%	MCLK period
S3	SAI_BCLK cycle time	20	—	ns
S4	SAI_BCLK pulse width high/low	40%	60%	BCLK period
S5	SAI_BCLK to SAI_FS output valid	—	2	ns
S6	SAI_BCLK to SAI_FS output invalid	0	—	ns
S7	SAI_BCLK to SAI_TXD valid	—	2	ns
S8	SAI_BCLK to SAI_TXD invalid	0	—	ns
S9	SAI_RXD/SAI_FS input setup before SAI_BCLK	2	—	ns
S10	SAI_RXD/SAI_FS input hold after SAI_BCLK	0	—	ns

<sup>1</sup> To achieve 50 MHz for BCLK operation, below configuration must be used:

- In TX, configure BCI=0 in SAI TCR2 register and FSD=1 in SAI TCR4 register.
- In RX, configure BCI=1 in SAI TCR2 register and FSD=0 in SAI TCR4 register.

Table 56. Master mode SAI timing (25 MHz)

Num	Characteristic	Min	Max	Unit
S1	SAI_MCLK cycle time	40	—	ns
S2	SAI_MCLK pulse width high/low	40%	60%	MCLK period
S3	SAI_BCLK cycle time	40	—	ns

Table 56. Master mode SAI timing (25 MHz) (continued)

Num	Characteristic	Min	Max	Unit
S4	SAI_BCLK pulse width high/low	40%	60%	BCLK period
S5	SAI_BCLK to SAI_FS output valid	—	2	ns
S6	SAI_BCLK to SAI_FS output invalid	0	—	ns
S7	SAI_BCLK to SAI_TXD valid	—	2	ns
S8	SAI_BCLK to SAI_TXD invalid	0	—	ns
S9	SAI_RXD/SAI_FS input setup before SAI_BCLK	12	—	ns
S10	SAI_RXD/SAI_FS input hold after SAI_BCLK	0	—	ns

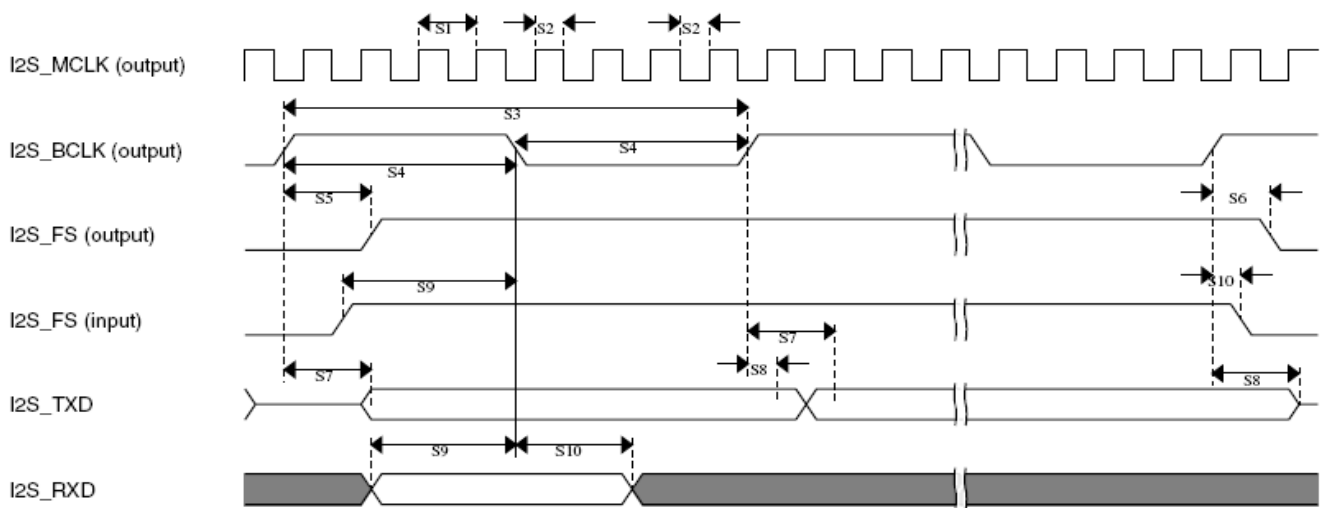

Figure 42. SAI timing—Master modes

Table 57. Slave mode SAI timing (50 MHz)<sup>1</sup>

Num	Characteristic	Min	Max	Unit
S11	SAI_BCLK cycle time (input)	20	—	ns
S12	SAI_BCLK pulse width high/low (input)	40%	60%	BCLK period
S13	SAI_FS input setup before SAI_BCLK	2	—	ns
S14	SAI_FA input hold after SAI_BCLK	2	—	ns
S17	SAI_RXD setup before SAI_BCLK	2	—	ns
S18	SAI_RXD hold after SAI_BCLK	2	—	ns

<sup>1</sup> TX does not support 50 MHz operation in Slave mode.

- To achieve 50 MHz BCLK in RX, configure BCI=1 in SAI TCR2 register and FSD=0 in SAI TCR4 register.

**Table 58. Slave mode SAI timing (25 MHz)**

Num	Characteristic	Min	Max	Unit
S11	SAI_BCLK cycle time (input)	40	—	ns
S12	SAI_BCLK pulse width high/low (input)	40%	60%	BCLK period
S13	SAI_FS input setup before SAI_BCLK	12	—	ns
S14	SAI_FA input hold after SAI_BCLK	2	—	ns
S15	SAI_BCLK to SAI_TXD/SAI_FS output valid	—	7	ns
S16	SAI_BCLK to SAI_TXD/SAI_FS output invalid	0	—	ns
S17	SAI_RXD setup before SAI_BCLK	12	—	ns
S18	SAI_RXD hold after SAI_BCLK	2	—	ns

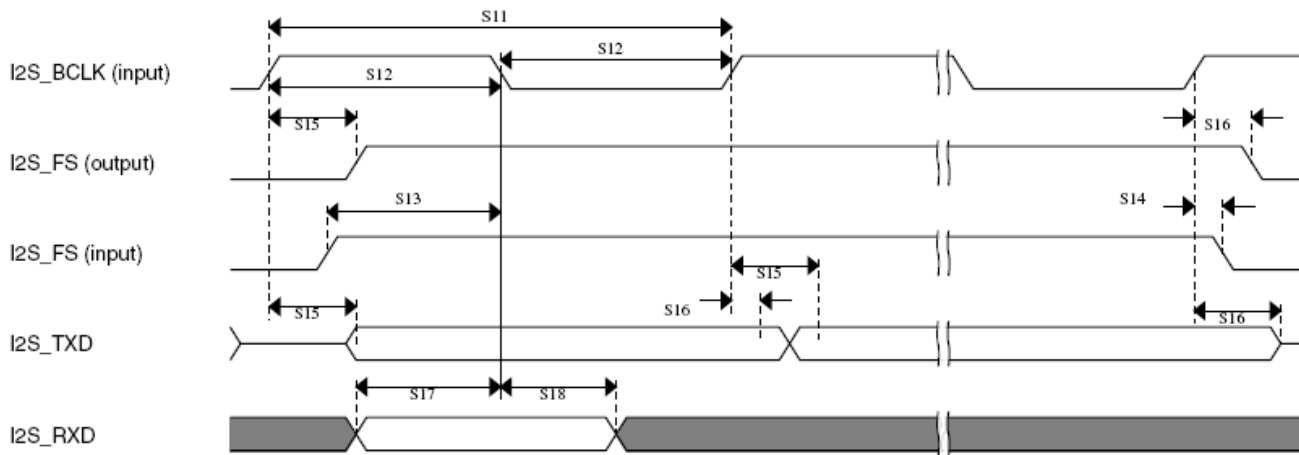

**Figure 43. SAI Timing — Slave Modes**

### 3.9.12 SPDIF timing parameters

The Sony/Philips Digital Interconnect Format (SPDIF) data is sent using the bi-phase marking code. When encoding, the SPDIF data signal is modulated by a clock that is twice the bit rate of the data signal.

Table 59 and Figure 44 and Figure 45 show SPDIF timing parameters for the Sony/Philips Digital Interconnect Format (SPDIF), including the timing of the modulating Rx clock (SPDIF\_SR\_CLK) for SPDIF in Rx mode and the timing of the modulating Tx clock (SPDIF\_ST\_CLK) for SPDIF in Tx mode.

Table 59. SPDIF timing parameters

Parameter	Symbol	Timing Parameter Range		Unit
		Min	Max	
SPDIF_IN Skew: asynchronous inputs, no specs apply	—	—	0.7	ns
SPDIF_OUT output (Load = 50 pf)				
• Skew	—	—	1.5	ns
• Transition rising	—	—	24.2	
• Transition falling	—	—	31.3	
SPDIF_OUT output (Load = 30 pf)				
• Skew	—	—	1.5	ns
• Transition rising	—	—	13.6	
• Transition falling	—	—	18.0	
Modulating Rx clock (SPDIF_SR_CLK) period	srckp	40.0	—	ns
SPDIF_SR_CLK high period	srckph	16.0	—	ns
SPDIF_SR_CLK low period	srckpl	16.0	—	ns
Modulating Tx clock (SPDIF_ST_CLK) period	stckp	40.0	—	ns
SPDIF_ST_CLK high period	stckph	16.0	—	ns
SPDIF_ST_CLK low period	stckpl	16.0	—	ns

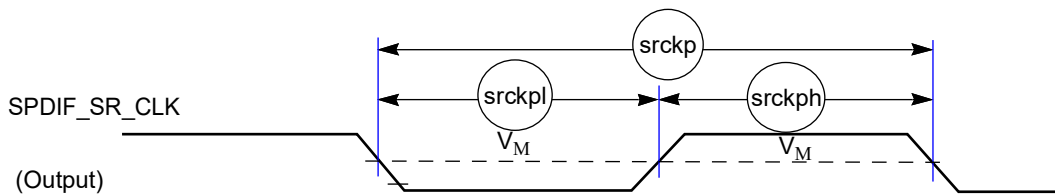

Figure 44. SPDIF\_SR\_CLK timing diagram

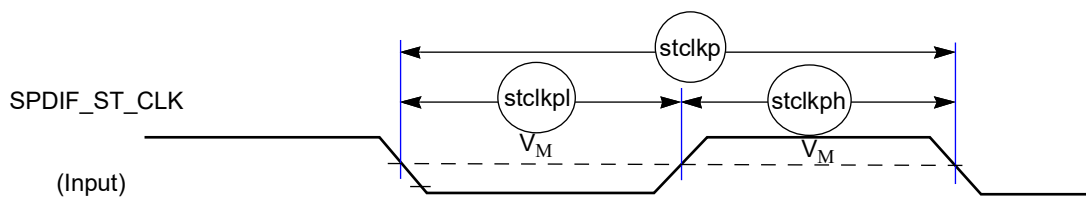

Figure 45. SPDIF\_ST\_CLK timing diagram

### 3.9.13 UART I/O configuration and timing parameters

#### 3.9.13.1 UART RS-232 I/O configuration in different modes

The i.MX 8M Mini UART interfaces can serve both as DTE or DCE device. This can be configured by the DCEDTE control bit (default 0—DCE mode). Table 60 shows the UART I/O configuration based on the enabled mode.

Table 60. UART I/O configuration vs. mode

Port	DTE Mode		DCE Mode	
	Direction	Description	Direction	Description
UARTx_RTS_B	Output	UARTx_RTS_B from DTE to DCE	Input	UARTx_RTS_B from DTE to DCE
UARTx_CTS_B	Input	UARTx_CTS_B from DCE to DTE	Output	UARTx_CTS_B from DCE to DTE
UARTx_TX_DATA	Input	Serial data from DCE to DTE	Output	Serial data from DCE to DTE
UARTx_RX_DATA	Output	Serial data from DTE to DCE	Input	Serial data from DTE to DCE

#### 3.9.13.2 UART RS-232 Serial mode timing

This section describes the electrical information of the UART module in the RS-232 mode.

##### 3.9.13.2.1 UART transmitter

Figure 46 depicts the transmit timing of UART in the RS-232 Serial mode, with 8 data bit/1 stop bit format. Table 61 lists the UART RS-232 Serial mode transmit timing characteristics.

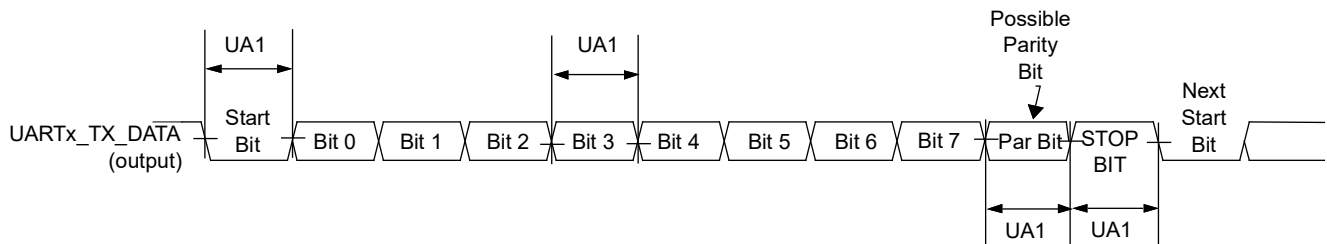

Figure 46. UART RS-232 Serial mode transmit timing diagram

Table 61. RS-232 Serial mode transmit timing parameters

ID	Parameter	Symbol	Min	Max	Unit
UA1	Transmit Bit Time	$t_{Tbit}$	$1/F_{baud\_rate}^1 - T_{ref\_clk}^2$	$1/F_{baud\_rate} + T_{ref\_clk}$	—

<sup>1</sup>  $F_{baud\_rate}$ : Baud rate frequency. The maximum baud rate the UART can support is  $(ipg\_perclk \text{ frequency})/16$ .

<sup>2</sup>  $T_{ref\_clk}$ : The period of UART reference clock  $ref\_clk$  ( $ipg\_perclk$  after RFDIV divider).

### 3.9.13.2.2 UART receiver

Figure 47 depicts the RS-232 Serial mode receive timing with 8 data bit/1 stop bit format. Table 62 lists Serial mode receive timing characteristics.

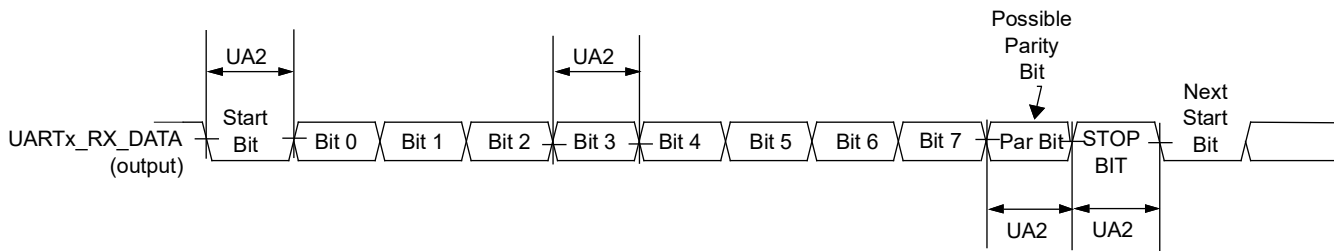

Figure 47. UART RS-232 Serial mode receive timing diagram

Table 62. RS-232 Serial mode receive timing parameters

ID	Parameter	Symbol	Min	Max	Unit
UA2	Receive Bit Time <sup>1</sup>	$t_{Rbit}$	$1/F_{baud\_rate}^2 - 1/(16 \times F_{baud\_rate})$	$1/F_{baud\_rate} + 1/(16 \times F_{baud\_rate})$	—

<sup>1</sup> The UART receiver can tolerate  $1/(16 \times F_{baud\_rate})$  tolerance in each bit. But accumulation tolerance in one frame must not exceed  $3/(16 \times F_{baud\_rate})$ .

<sup>2</sup>  $F_{baud\_rate}$ : Baud rate frequency. The maximum baud rate the UART can support is  $(ipg\_perclk \text{ frequency})/16$ .

## 3.9.14 USB PHY parameters

This section describes the USB-OTG PHY parameters.

### 3.9.14.1 Pad/Package/Board connections

The USBx\_VBUS pin cannot directly connect to the 5 V VBUS voltage on the USB2.0 link.

Each USBx\_VBUS pin must be isolated by an external 30 K $\Omega$  1% precision resistor.

The USB 2.0 PHY uses USBx\_TXRTUNE and an external resistor to calibrate the USBx\_DP/DN 45  $\Omega$  source impedance. The external resistor value is 200  $\Omega$  1% precision on each of USBx\_TXRTUNE pad to ground.

### 3.9.14.2 USB PHY worst power consumption

Table 63 shows the USB 2.0 PHY worst power dissipation.

**Table 63. USB 2.0 PHY worst power dissipation**

Mode	VDD_USB_0P8	VDD_USB_3P3	VDD_USB_1P8	Total Power
HS TX	8.286	4.63	23.409	70.448
FS TX	6.767	12.52	5.968	63.22
LS TX	7.001	13.58	6.224	67.779
Suspend	0.752	0.164	0.106	1.465
Sleep	0.761	0.163	0.106	1.472

## 4 Boot mode configuration

This section provides information on Boot mode configuration pins allocation and boot devices interfaces allocation.

### 4.1 Boot mode configuration pins

Table 64 provides boot options, functionality, fuse values, and associated pins. Several input pins are also sampled at reset and can be used to override fuse values, depending on the value of BT\_FUSE\_SEL fuse. The boot option pins are in effect when BT\_FUSE\_SEL fuse is '0' (cleared, which is the case for an unblown fuse). For detailed Boot mode options configured by the Boot mode pins, see the “System Boot, Fusemap, and eFuse” chapter in the *i.MX 8M Mini Applications Processor Reference Manual* (IMX8MMRM).

**Table 64. Fuses and associated pins used for boot**

Pin	Direction at Reset	eFuse name	State during reset (POR_B asserted)	State after reset (POR_B deasserted)	Details
BOOT_MODE0	Input	N/A	Input with pull down	Input with pull down	Boot mode selection
BOOT_MODE1	Input	N/A	Input with pull down	Input with pull down	
SAI1_RXD0	Input	BOOT_CFG[0]	Input with pull down	Input with pull down	Boot options pin value overrides fuse settings for BT_FUSE_SEL = "0". Signal configuration as fuse override input at power up. These are special I/O lines that control the boot configuration during product development. In production, the boot configuration can be controlled by fuses.
SAI1_RXD1	Input	BOOT_CFG[1]	Input with pull down	Input with pull down	
SAI1_RXD2	Input	BOOT_CFG[2]	Input with pull down	Input with pull down	
SAI1_RXD3	Input	BOOT_CFG[3]	Input with pull down	Input with pull down	
SAI1_RXD4	Input	BOOT_CFG[4]	Input with pull down	Input with pull down	
SAI1_RXD5	Input	BOOT_CFG[5]	Input with pull down	Input with pull down	
SAI1_RXD6	Input	BOOT_CFG[6]	Input with pull down	Input with pull down	
SAI1_RXD7	Input	BOOT_CFG[7]	Input with pull down	Input with pull down	
SAI1_TXD0	Input	BOOT_CFG[8]	Input with pull down	Input with pull down	
SAI1_TXD1	Input	BOOT_CFG[9]	Input with pull down	Input with pull down	
SAI1_TXD2	Input	BOOT_CFG[10]	Input with pull down	Input with pull down	
SAI1_TXD3	Input	BOOT_CFG[11]	Input with pull down	Input with pull down	
SAI1_TXD4	Input	BOOT_CFG[12]	Input with pull down	Input with pull down	
SAI1_TXD5	Input	BOOT_CFG[13]	Input with pull down	Input with pull down	
SAI1_TXD6	Input	BOOT_CFG[14]	Input with pull down	Input with pull down	

## 4.2 Boot device interface allocation

Table 65 lists the interfaces that can be used by the boot process in accordance with the specific Boot mode configuration. The table also describes the interface’s specific modes and IOMUXC allocation, which are configured during boot when appropriate.

**Table 65. Interface allocation during boot**

Interface	IP Instance	Allocated Pads During Boot	Comment
SPI	ECSPI-1	ECSPI1_SCLK, ECSPI1_MOSI, ECSPI1_MISO, ECSPI1_SS0	The chip-select pin used depends on the fuse “CS select (SPI only)”.
SPI	ECSPI-2	ECSPI2_SCLK, ECSPI2_MOSI, ECSPI2_MISO, ECSPI2_SS0	The chip-select pin used depends on the fuse “CS select (SPI only)”.
SPI	ECSPI-3	UART1_RXD, UART1_TXD, UART2_RXD, UART2_TXD	The chip-select pin used depends on the fuse “CS select (SPI only)”.
NAND Flash	GPMI	NAND_ALE, NAND_CE0_B, NAND_CLE, NAND_DATA00, NAND_DATA01, NAND_DATA02, NAND_DATA03, NAND_DATA04, NAND_DATA05, NAND_DATA06, NAND_DATA07, NAND_DQS, NAND_RE_B, NAND_READY_B, NAND_WE_B, NAND_WP_B	8-bit, only CS0 is supported.
SD/MMC	USDHC-1	GPIO1_IO03, GPIO1_IO06, GPIO1_IO07, SD1_RESET_B, SD1_CLK, SD1_CMD, SD1_STROBE, SD1_DATA0, SD1_DATA1, SD1_DATA2, SD1_DATA3, SD1_DATA4, SD1_DATA5, SD1_DATA6, SD1_DATA7	1, 4, or 8-bit
SD/MMC	USDHC-2	GPIO1_IO04, GPIO1_IO08, GPIO1_IO07, SD2_RESET_B, SD2_WP, SD2_CLK, SD2_CMD, SD2_DATA0, SD2_DATA1, SD2_DATA2, SD2_DATA3	1 or 4-bit
SD/MMC	USDHC-3	NAND_CE1_B, NAND_CE2_B, NAND_CE3_B, NAND_CLE, NAND_DATA02, NAND_DATA03, NAND_DATA04, NAND_DATA05, NAND_DATA06, NAND_DATA07, NAND_RE_B, NAND_READY_B, NAND_WE_B, NAND_WP_B	1, 4, or 8-bit
FlexSPI	FlexSPI	NAND_ALE, NAND_CE0_B, NAND_CE1_B, NAND_CE2_B, NAND_CE3_B, NAND_CLE, NAND_DATA00, NAND_DATA01, NAND_DATA02, NAND_DATA03, NAND_DATA04, NAND_DATA05, NAND_DATA06, NAND_DATA07, NAND_DQS, NAND_RE_B	For FlexSPI flash
USB	USB_OTG PHY	Dedicated USB pins	—

## 5 Package information and contact assignments

This section includes the contact assignment information and mechanical package drawing.

### 5.1 14 x 14 mm package information

#### 5.1.1 14 x 14 mm, 0.5 mm pitch, ball matrix

[Figure 48](#) shows the top, bottom, and side views of the 14 × 14 mm FCBGA package.

Package information and contact assignments

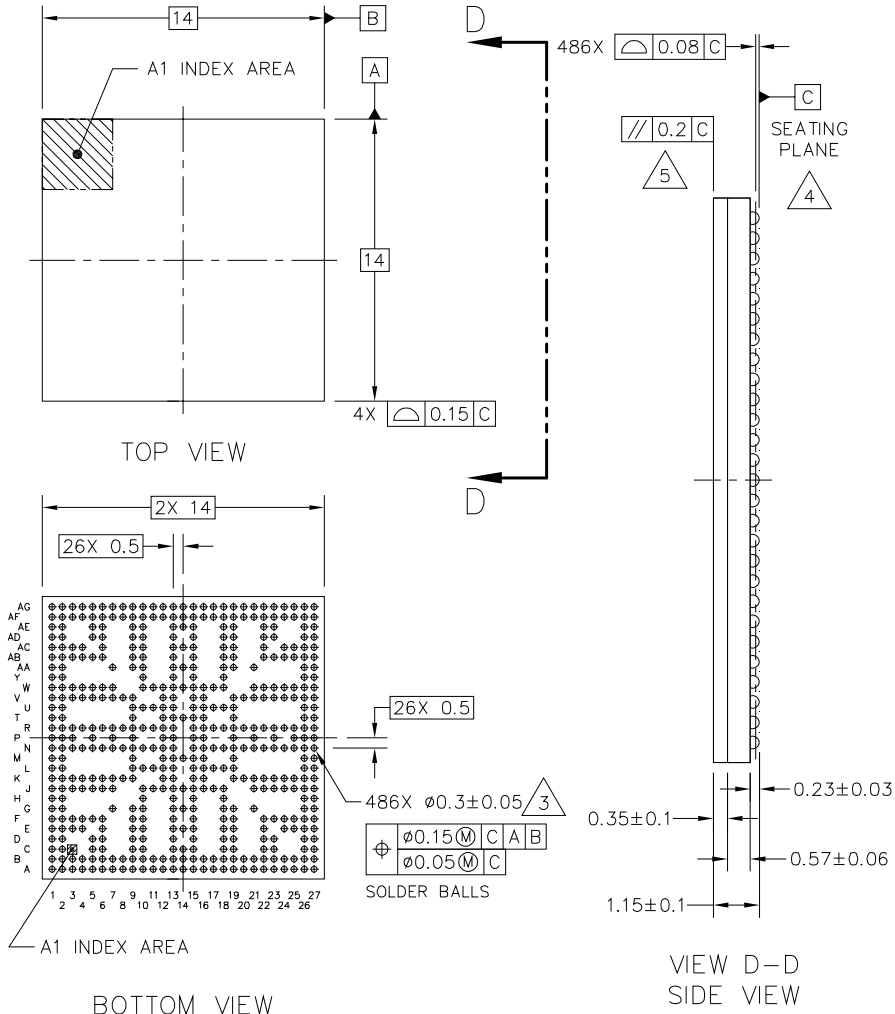

© NXP SEMICONDUCTORS N.V. ALL RIGHTS RESERVED	MECHANICAL OUTLINE	PRINT VERSION NOT TO SCALE
TITLE: FCPBGA, MOLDED ARRAY, 14 X 14 X 1.15 PKG, 0.5 MM PITCH, 486 I/O	DOCUMENT NO: 98ASA01200D	REV: B
	STANDARD: NON-JEDEC	
	SOT1967-1	02 AUG 2018

Figure 48. 14 X 14 MM BGA, case x package top, bottom, and side views

## 5.1.2 14 x 14 mm supplies contact assignments and functional contact assignments

Table 66 shows supplies contact assignments for the 14 x 14 mm package.

**Table 66. i.MX 8M Mini 14 x 14 mm supplies contact assignments**

Supply Rail Name	Ball(s) Position(s)	Remark
NC	J18	—
NVCC_CLK	M19	Supply for CLK interface
NVCC_DRAM	P7, K8, N8, R8, V8, K9, L9, M9, N9, R9, T9, U9, V9	Supply for DRAM interface
NVCC_ECSPi	H10	Supply for ECSPi interface
NVCC_ENET	W22	Supply for ENET interface
NVCC_GPIO1	W12	Supply for GPIO1 interface
NVCC_I2C	J11	Supply for I2C interface
NVCC_JTAG	L19	Supply for JTAG interface
NVCC_NAND	U19	Supply for NAND interface
NVCC_SAI1	W18	Supply for SAI interface
NVCC_SAI2	V19	Supply for SAI interface
NVCC_SAI3	Y10	Supply for SAI interface
NVCC_SAI5	W17	Supply for SAI interface
NVCC_SD1	V20	Supply for SD interface
NVCC_SD2	V22	Supply for SD interface
NVCC_SNVS_1P8	J22	Supply for SNVS interface
NVCC_UART	J12	Supply for UART interface
PVCC0_1P8	AB13	Digital IO pre-drive
PVCC1_1P8	T19	Digital IO pre-drive
PVCC2_1P8	J13	Digital IO pre-drive
VDD_24M_XTAL_1P8	N19	Supply for XTAL
VDD_ANA_0P8	L17, N17	Supply for Analog logic
VDD_ANA0_1P8	AA14, Y15	Supply for Analog logic
VDD_ANA1_1P8	P19, N20	Supply for Analog logic
VDD_ARM	R13, T13, U13, V13, W13, T14, W14, R15, T15, U15, V15, W15, V16, W16	Supply for ARM
VDD_ARM_PLL_0P8	P16	Supply for ARM PLL
VDD_ARM_PLL_1P8	R19	Supply for ARM PLL
VDD_DRAM	J10, L10, N10, R10, U10, W10	Supply for DRAM module

Package information and contact assignments

**Table 66. i.MX 8M Mini 14 x 14 mm supplies contact assignments (continued)**

VDD_DRAM_PLL_0P8	P9	Supply for DRAM PLL
VDD_DRAM_PLL_1P8	P5	Supply for DRAM PLL
VDD_GPU	R11, U11, W11, P12, V12	Supply for GPU
VDD_MIPI_0P9	J14	Supply for MIPI PHY
VDD_MIPI_1P2	J15	Supply for MIPI PHY
VDD_MIPI_1P8	H13	Supply for MIPI PHY
VDD_PCI_0P8	J16	Supply for PCIe PHY
VDD_PCI_1P8	G14	Supply for PCIe PHY
VDD_SNVS_0P8	K22	Supply for SNVS logic
VDD_SOC	N13, K15, L15, M15, N15, K16, R17, U17, L18, N18, R18, U18	Supply for SOC logic
VDD_USB_0P8	J17	Supply for USB PHY
VDD_USB_1P8	H15	Supply for USB PHY
VDD_USB_3P3	K19	Supply for USB PHY
VDD_VPU	L11, N11, K12, K13, L13, M13, M14	Supply for VPU
VSS	A1, AG1, C2, H2, Y2, AE2, B3, E3, F3, J3, K3, N3, P3, R3, V3, W3, AB3, AC3, AF3, C5, AE5, C6, AE6, G7, J7, K7, N7, R7, V7, W7, AA7, C9, G9, AA9, AE9, C10, G10, AA10, AE10, L12, M12, N12, R12, T12, U12, C13, G13, P13, Y13, AA13, AE13, C14, AE14, C15, G15, P15, AA15, AE15, L16, M16, N16, R16, T16, U16, C18, G18, H18, Y18, AA18, AE18, C19, G19, AA19, AE19, K20, R20, G21, J21, K21, N21, P21, R21, V21, W21, AA21, C22, AE22, C23, AE23, E25, F25, J25, K25, N25, P25, R25, V25, W25, AB25, AC25, B26, A27, AG27	—

Table 67 shows an alpha-sorted list of functional contact assignments for the 14 x 14 mm package.

**Table 67. i.MX 8M Mini 14 x 14 mm functional contact assignments**

Ball name	Ball	Power group	Ball type	Reset condition		
				Default mode	Default function	Input/Output status
24M_XTALI	B27	VDD_24M_XTAL_1P8	ANALOG	—	—	Input
24M_XTALO	C26	VDD_24M_XTAL_1P8	ANALOG	—	—	Output
BOOT_MODE0	G26	NVCC_JTAG	GPIO	ALT0	ccmsrcgpcmix.BOOT_MODE[0]	Input with PD
BOOT_MODE1	G27	NVCC_JTAG	GPIO	ALT0	ccmsrcgpcmix.BOOT_MODE[1]	Input with PD

Table 67. i.MX 8M Mini 14 x 14 mm functional contact assignments (continued)

Ball name	Ball	Power group	Ball type	Reset condition		
				Default mode	Default function	Input/Output status
CLKIN1	H27	NVCC_CLK	GPIO	—	—	Input without PU/PD
CLKIN2	J27	NVCC_CLK	GPIO	—	—	Input without PU/PD
CLKOUT1	H26	NVCC_CLK	GPIO	—	—	Output low without PU/PD
CLKOUT2	J26	NVCC_CLK	GPIO	—	—	Output low without PU/PD
DRAM_AC00	F4	NVCC_DRAM	DDR	—	—	Output low
DRAM_AC01	F5	NVCC_DRAM	DDR	—	—	Output low
DRAM_AC02	K4	NVCC_DRAM	DDR	—	—	Input
DRAM_AC03	J4	NVCC_DRAM	DDR	—	—	Input
DRAM_AC04	L2	NVCC_DRAM	DDR	—	—	Input
DRAM_AC05	L1	NVCC_DRAM	DDR	—	—	Input
DRAM_AC06	F6	NVCC_DRAM	DDR	—	—	Input
DRAM_AC07	J5	NVCC_DRAM	DDR	—	—	Input
DRAM_AC08	J6	NVCC_DRAM	DDR	—	—	Input
DRAM_AC09	K6	NVCC_DRAM	DDR	—	—	Input
DRAM_AC10	E4	NVCC_DRAM	DDR	—	—	Input
DRAM_AC11	D5	NVCC_DRAM	DDR	—	—	Input
DRAM_AC12	N4	NVCC_DRAM	DDR	—	—	Input
DRAM_AC13	N5	NVCC_DRAM	DDR	—	—	Input
DRAM_AC14	K5	NVCC_DRAM	DDR	—	—	Input
DRAM_AC15	N6	NVCC_DRAM	DDR	—	—	Input
DRAM_AC16	M1	NVCC_DRAM	DDR	—	—	Input
DRAM_AC17	M2	NVCC_DRAM	DDR	—	—	Input
DRAM_AC19	N2	NVCC_DRAM	DDR	—	—	Input
DRAM_AC20	AB4	NVCC_DRAM	DDR	—	—	Output low
DRAM_AC21	AB5	NVCC_DRAM	DDR	—	—	Output low
DRAM_AC22	W4	NVCC_DRAM	DDR	—	—	Input
DRAM_AC23	V4	NVCC_DRAM	DDR	—	—	Input

Table 67. i.MX 8M Mini 14 x 14 mm functional contact assignments (continued)

Ball name	Ball	Power group	Ball type	Reset condition		
				Default mode	Default function	Input/Output status
DRAM_AC24	U2	NVCC_DRAM	DDR	—	—	Input
DRAM_AC25	U1	NVCC_DRAM	DDR	—	—	Input
DRAM_AC26	N1	NVCC_DRAM	DDR	—	—	Input
DRAM_AC27	R6	NVCC_DRAM	DDR	—	—	Input
DRAM_AC28	W6	NVCC_DRAM	DDR	—	—	Input
DRAM_AC29	V6	NVCC_DRAM	DDR	—	—	Input
DRAM_AC30	AC4	NVCC_DRAM	DDR	—	—	Input
DRAM_AC31	AD5	NVCC_DRAM	DDR	—	—	Input
DRAM_AC32	R4	NVCC_DRAM	DDR	—	—	Input
DRAM_AC33	R5	NVCC_DRAM	DDR	—	—	Input
DRAM_AC34	T1	NVCC_DRAM	DDR	—	—	Input
DRAM_AC35	T2	NVCC_DRAM	DDR	—	—	Input
DRAM_AC36	V5	NVCC_DRAM	DDR	—	—	Input
DRAM_AC37	W5	NVCC_DRAM	DDR	—	—	Input
DRAM_AC38	AB6	NVCC_DRAM	DDR	—	—	Input
DRAM_ALERT_N	R2	NVCC_DRAM	DDR	—	—	Input
DRAM_DM0	A4	NVCC_DRAM	DDR	—	—	Input
DRAM_DM1	F1	NVCC_DRAM	DDR	—	—	Input
DRAM_DM2	AB1	NVCC_DRAM	DDR	—	—	Input
DRAM_DM3	AG4	NVCC_DRAM	DDR	—	—	Input
DRAM_DQ00	A5	NVCC_DRAM	DDR	—	—	Input
DRAM_DQ01	B5	NVCC_DRAM	DDR	—	—	Input
DRAM_DQ02	D2	NVCC_DRAM	DDR	—	—	Input
DRAM_DQ03	D1	NVCC_DRAM	DDR	—	—	Input
DRAM_DQ04	C1	NVCC_DRAM	DDR	—	—	Input
DRAM_DQ05	B1	NVCC_DRAM	DDR	—	—	Input
DRAM_DQ06	A3	NVCC_DRAM	DDR	—	—	Input
DRAM_DQ07	B4	NVCC_DRAM	DDR	—	—	Input
DRAM_DQ08	F2	NVCC_DRAM	DDR	—	—	Input
DRAM_DQ09	G2	NVCC_DRAM	DDR	—	—	Input

Table 67. i.MX 8M Mini 14 x 14 mm functional contact assignments (continued)

Ball name	Ball	Power group	Ball type	Reset condition		
				Default mode	Default function	Input/Output status
DRAM_DQ10	J1	NVCC_DRAM	DDR	—	—	Input
DRAM_DQ11	J2	NVCC_DRAM	DDR	—	—	Input
DRAM_DQ12	K2	NVCC_DRAM	DDR	—	—	Input
DRAM_DQ13	K1	NVCC_DRAM	DDR	—	—	Input
DRAM_DQ14	E1	NVCC_DRAM	DDR	—	—	Input
DRAM_DQ15	E2	NVCC_DRAM	DDR	—	—	Input
DRAM_DQ16	AB2	NVCC_DRAM	DDR	—	—	Input
DRAM_DQ17	AA2	NVCC_DRAM	DDR	—	—	Input
DRAM_DQ18	W1	NVCC_DRAM	DDR	—	—	Input
DRAM_DQ19	W2	NVCC_DRAM	DDR	—	—	Input
DRAM_DQ20	V2	NVCC_DRAM	DDR	—	—	Input
DRAM_DQ21	V1	NVCC_DRAM	DDR	—	—	Input
DRAM_DQ22	AC1	NVCC_DRAM	DDR	—	—	Input
DRAM_DQ23	AC2	NVCC_DRAM	DDR	—	—	Input
DRAM_DQ24	AG5	NVCC_DRAM	DDR	—	—	Input
DRAM_DQ25	AF5	NVCC_DRAM	DDR	—	—	Input
DRAM_DQ26	AD2	NVCC_DRAM	DDR	—	—	Input
DRAM_DQ27	AD1	NVCC_DRAM	DDR	—	—	Input
DRAM_DQ28	AE1	NVCC_DRAM	DDR	—	—	Input
DRAM_DQ29	AF1	NVCC_DRAM	DDR	—	—	Input
DRAM_DQ30	AG3	NVCC_DRAM	DDR	—	—	Input
DRAM_DQ31	AF4	NVCC_DRAM	DDR	—	—	Input
DRAM_DQS0_N	B2	NVCC_DRAM	—	—	—	Input
DRAM_DQS0_P	A2	NVCC_DRAM	DDRCLK	—	—	Input
DRAM_DQS1_N	H1	NVCC_DRAM	—	—	—	Input
DRAM_DQS1_P	G1	NVCC_DRAM	DDRCLK	—	—	Input
DRAM_DQS2_N	Y1	NVCC_DRAM	—	—	—	Input
DRAM_DQS2_P	AA1	NVCC_DRAM	DDRCLK	—	—	Input
DRAM_DQS3_N	AF2	NVCC_DRAM	—	—	—	Input
DRAM_DQS3_P	AG2	NVCC_DRAM	DDRCLK	—	—	Input

Table 67. i.MX 8M Mini 14 x 14 mm functional contact assignments (continued)

Ball name	Ball	Power group	Ball type	Reset condition		
				Default mode	Default function	Input/Output status
DRAM_RESET_N	R1	NVCC_DRAM	DDR	—	—	Output low
DRAM_VREF	P1	NVCC_DRAM	DDR	—	—	—
DRAM_ZN	P2	NVCC_DRAM	DDR	—	—	—
ECSPI1_MISO	A7	NVCC_ECSPi	GPIO	ALT5	GPIO5.IO[8]	Input with PD
ECSPI1_MOSI	B7	NVCC_ECSPi	GPIO	ALT5	GPIO5.IO[7]	Input with PD
ECSPI1_SCLK	D6	NVCC_ECSPi	GPIO	ALT5	GPIO5.IO[6]	Input with PD
ECSPI1_SS0	B6	NVCC_ECSPi	GPIO	ALT5	GPIO5.IO[9]	Input with PD
ECSPI2_MISO	A8	NVCC_ECSPi	GPIO	ALT5	GPIO5.IO[12]	Input with PD
ECSPI2_MOSI	B8	NVCC_ECSPi	GPIO	ALT5	GPIO5.IO[11]	Input with PD
ECSPI2_SCLK	E6	NVCC_ECSPi	GPIO	ALT5	GPIO5.IO[10]	Input with PD
ECSPI2_SS0	A6	NVCC_ECSPi	GPIO	ALT5	GPIO5.IO[13]	Input with PD
ENET_MDC	AC27	NVCC_ENET	GPIO	ALT5	GPIO1.IO[16]	Input with PD
ENET_MDIO	AB27	NVCC_ENET	GPIO	ALT5	GPIO1.IO[17]	Input with PD
ENET_RD0	AE27	NVCC_ENET	GPIO	ALT5	GPIO1.IO[26]	Input with PD
ENET_RD1	AD27	NVCC_ENET	GPIO	ALT5	GPIO1.IO[27]	Input with PD
ENET_RD2	AD26	NVCC_ENET	GPIO	ALT5	GPIO1.IO[28]	Input with PD
ENET_RD3	AC26	NVCC_ENET	GPIO	ALT5	GPIO1.IO[29]	Input with PD
ENET_RXC	AE26	NVCC_ENET	GPIO	ALT5	GPIO1.IO[25]	Input with PD
ENET_RX_CTL	AF27	NVCC_ENET	GPIO	ALT5	GPIO1.IO[24]	Input with PD
ENET_TD0	AG26	NVCC_ENET	GPIO	ALT5	GPIO1.IO[21]	Input with PD
ENET_TD1	AF26	NVCC_ENET	GPIO	ALT5	GPIO1.IO[20]	Input with PD
ENET_TD2	AG25	NVCC_ENET	GPIO	ALT5	GPIO1.IO[19]	Input with PD
ENET_TD3	AF25	NVCC_ENET	GPIO	ALT5	GPIO1.IO[18]	Input with PD
ENET_TXC	AG24	NVCC_ENET	GPIO	ALT5	GPIO1.IO[23]	Input with PD
ENET_TX_CTL	AF24	NVCC_ENET	GPIO	ALT5	GPIO1.IO[22]	Input with PD
GPIO1_IO00	AG14	NVCC_GPIO1	GPIO	ALT0	GPIO1.IO[0]	Input with PD
GPIO1_IO01 <sup>1</sup>	AF14	NVCC_GPIO1	GPIO	ALT0	GPIO1.IO[1]	Output low
GPIO1_IO02	AG13	NVCC_GPIO1	GPIO	ALT0	GPIO1.IO[2]	Input with PU
GPIO1_IO03	AF13	NVCC_GPIO1	GPIO	ALT0	GPIO1.IO[3]	Input with PD
GPIO1_IO04	AG12	NVCC_GPIO1	GPIO	ALT0	GPIO1.IO[4]	Input with PD

Table 67. i.MX 8M Mini 14 x 14 mm functional contact assignments (continued)

Ball name	Ball	Power group	Ball type	Reset condition		
				Default mode	Default function	Input/Output status
GPIO1_IO05 <sup>2</sup>	AF12	NVCC_GPIO1	GPIO	ALT0	GPIO1.IO[5]	Output high
GPIO1_IO06	AG11	NVCC_GPIO1	GPIO	ALT0	GPIO1.IO[6]	Input with PD
GPIO1_IO07	AF11	NVCC_GPIO1	GPIO	ALT0	GPIO1.IO[7]	Input with PU
GPIO1_IO08	AG10	NVCC_GPIO1	GPIO	ALT0	GPIO1.IO[8]	Input with PD
GPIO1_IO09	AF10	NVCC_GPIO1	GPIO	ALT0	GPIO1.IO[9]	Input with PD
GPIO1_IO10	AD10	NVCC_GPIO1	GPIO	ALT0	GPIO1.IO[10]	Input with PD
GPIO1_IO11	AC10	NVCC_GPIO1	GPIO	ALT0	GPIO1.IO[11]	Input with PD
GPIO1_IO12	AB10	NVCC_GPIO1	GPIO	ALT0	GPIO1.IO[12]	Input with PD
GPIO1_IO13	AD9	NVCC_GPIO1	GPIO	ALT0	GPIO1.IO[13]	Input with PD
GPIO1_IO14	AC9	NVCC_GPIO1	GPIO	ALT0	GPIO1.IO[14]	Input with PD
GPIO1_IO15	AB9	NVCC_GPIO1	GPIO	ALT0	GPIO1.IO[15]	Input with PD
I2C1_SCL	E9	NVCC_I2C	GPIO	ALT5	GPIO5.IO[14]	Input with PD
I2C1_SDA	F9	NVCC_I2C	GPIO	ALT5	GPIO5.IO[15]	Input with PD
I2C2_SCL	D10	NVCC_I2C	GPIO	ALT5	GPIO5.IO[16]	Input with PD
I2C2_SDA	D9	NVCC_I2C	GPIO	ALT5	GPIO5.IO[17]	Input with PD
I2C3_SCL	E10	NVCC_I2C	GPIO	ALT5	GPIO5.IO[18]	Input with PD
I2C3_SDA	F10	NVCC_I2C	GPIO	ALT5	GPIO5.IO[19]	Input with PD
I2C4_SCL	D13	NVCC_I2C	GPIO	ALT5	GPIO5.IO[20]	Input with PD
I2C4_SDA	E13	NVCC_I2C	GPIO	ALT5	GPIO5.IO[21]	Input with PD
JTAG_MOD	D27	NVCC_JTAG	GPIO	ALT0	cjtag_wrapper.MOD	Input with PD
JTAG_TCK	F26	NVCC_JTAG	GPIO	ALT0	cjtag_wrapper.TCK	Input with PU
JTAG_TDI	E27	NVCC_JTAG	GPIO	ALT0	cjtag_wrapper.TDI	Input with PU
JTAG_TDO	E26	NVCC_JTAG	GPIO	ALT0	cjtag_wrapper.TDO	Input with PU
JTAG_TMS	F27	NVCC_JTAG	GPIO	ALT0	cjtag_wrapper.TMS	Input with PU
JTAG_TRST_B	C27	NVCC_JTAG	GPIO	ALT0	cjtag_wrapper.TRST_B	Input with PU
MIPI_CSI_CLK_N	A16	VDD_MIPI_1P8	PHY	—	—	Input
MIPI_CSI_CLK_P	B16	VDD_MIPI_1P8	PHY	—	—	Input
MIPI_CSI_D0_N	A14	VDD_MIPI_1P8	PHY	—	—	Input
MIPI_CSI_D0_P	B14	VDD_MIPI_1P8	PHY	—	—	Input
MIPI_CSI_D1_N	A15	VDD_MIPI_1P8	PHY	—	—	Input

Table 67. i.MX 8M Mini 14 x 14 mm functional contact assignments (continued)

Ball name	Ball	Power group	Ball type	Reset condition		
				Default mode	Default function	Input/Output status
MIPI_CSI_D1_P	B15	VDD_MIPI_1P8	PHY	—	—	Input
MIPI_CSI_D2_N	A17	VDD_MIPI_1P8	PHY	—	—	Input
MIPI_CSI_D2_P	B17	VDD_MIPI_1P8	PHY	—	—	Input
MIPI_CSI_D3_N	A18	VDD_MIPI_1P8	PHY	—	—	Input
MIPI_CSI_D3_P	B18	VDD_MIPI_1P8	PHY	—	—	Input
MIPI_DSI_CLK_N	A11	VDD_MIPI_1P8	PHY	—	—	Output low
MIPI_DSI_CLK_P	B11	VDD_MIPI_1P8	PHY	—	—	Output low
MIPI_DSI_D0_N	A9	VDD_MIPI_1P8	PHY	—	—	Output low
MIPI_DSI_D0_P	B9	VDD_MIPI_1P8	PHY	—	—	Output low
MIPI_DSI_D1_N	A10	VDD_MIPI_1P8	PHY	—	—	Output low
MIPI_DSI_D1_P	B10	VDD_MIPI_1P8	PHY	—	—	Output low
MIPI_DSI_D2_N	A12	VDD_MIPI_1P8	PHY	—	—	Output low
MIPI_DSI_D2_P	B12	VDD_MIPI_1P8	PHY	—	—	Output low
MIPI_DSI_D3_N	A13	VDD_MIPI_1P8	PHY	—	—	Output low
MIPI_DSI_D3_P	B13	VDD_MIPI_1P8	PHY	—	—	Output low
MIPI_VREG_CAP	D15	0.35 - 0.45 V	PHY	—	—	Output
NAND_ALE	N22	NVCC_NAND	GPIO	ALT5	GPIO3.IO[0]	Input with PD
NAND_CE0_B	N24	NVCC_NAND	GPIO	ALT5	GPIO3.IO[1]	Input with PU
NAND_CE1_B	P27	NVCC_NAND	GPIO	ALT5	GPIO3.IO[2]	Input with PD
NAND_CE2_B	M27	NVCC_NAND	GPIO	ALT5	GPIO3.IO[3]	Input with PD
NAND_CE3_B	L27	NVCC_NAND	GPIO	ALT5	GPIO3.IO[4]	Input with PD
NAND_CLE	K27	NVCC_NAND	GPIO	ALT5	GPIO3.IO[5]	Input with PD
NAND_DATA00	P23	NVCC_NAND	GPIO	ALT5	GPIO3.IO[6]	Input with PD
NAND_DATA01	K24	NVCC_NAND	GPIO	ALT5	GPIO3.IO[7]	Input with PD
NAND_DATA02	K23	NVCC_NAND	GPIO	ALT5	GPIO3.IO[8]	Input with PD
NAND_DATA03	N23	NVCC_NAND	GPIO	ALT5	GPIO3.IO[9]	Input with PD
NAND_DATA04	M26	NVCC_NAND	GPIO	ALT5	GPIO3.IO[10]	Input with PD
NAND_DATA05	L26	NVCC_NAND	GPIO	ALT5	GPIO3.IO[11]	Input with PD
NAND_DATA06	K26	NVCC_NAND	GPIO	ALT5	GPIO3.IO[12]	Input with PD
NAND_DATA07	N26	NVCC_NAND	GPIO	ALT5	GPIO3.IO[13]	Input with PD

Table 67. i.MX 8M Mini 14 x 14 mm functional contact assignments (continued)

Ball name	Ball	Power group	Ball type	Reset condition		
				Default mode	Default function	Input/Output status
NAND_DQS	R22	NVCC_NAND	GPIO	ALT5	GPIO3.IO[14]	Input with PD
NAND_RE_B	N27	NVCC_NAND	GPIO	ALT5	GPIO3.IO[15]	Input with PU
NAND_READY_B	P26	NVCC_NAND	GPIO	ALT5	GPIO3.IO[16]	Input with PD
NAND_WE_B	R26	NVCC_NAND	GPIO	ALT5	GPIO3.IO[17]	Input with PD
NAND_WP_B	R27	NVCC_NAND	GPIO	ALT5	GPIO3.IO[18]	Input with PD
ONOFF	A25	NVCC_SNVS_1P8	GPIO	ALT0	snvsmix.ONOFF	Input without PU/PD
PCIE_CLK_N	A21	VDD_PCI_1P8	PHY	—	—	High-Z
PCIE_CLK_P	B21	VDD_PCI_1P8	PHY	—	—	High-Z
PCIE_RESREF	D19	VDD_PCI_1P8	PHY	—	—	High-Z
PCIE_RXN_N	A19	VDD_PCI_1P8	PHY	—	—	Input, High-Z
PCIE_RXN_P	B19	VDD_PCI_1P8	PHY	—	—	Input, High-Z
PCIE_TXN_N	A20	VDD_PCI_1P8	PHY	—	—	Output, High-Z
PCIE_TXN_P	B20	VDD_PCI_1P8	PHY	—	—	Output, High-Z
PMIC_ON_REQ	A24	NVCC_SNVS_1P8	GPIO	ALT0	snvsmix.PMIC_ON_REQ	Open-drain output high with PU
PMIC_STBY_REQ	E24	NVCC_SNVS_1P8	GPIO	ALT0	ccmsrcgpcmix.PMIC_STBY_REQ	Output low with PD
POR_B	B24	NVCC_SNVS_1P8	GPIO	ALT0	snvsmix.POR_B	Input without PU/PD
RTC_XTALI	A26	NVCC_SNVS_1P8	ANALOG	—	—	Input
RTC_XTALO	B25	NVCC_SNVS_1P8	ANALOG	—	—	Output, inverted of RTC_XTALI
RTC_RESET_B	F24	NVCC_SNVS_1P8	GPIO	ALT0	snvsmix.RTC_POR_B	Input without PU/PD
SAI1_MCLK	AB18	NVCC_SAI1	GPIO	ALT5	GPIO4.IO[20]	Input with PD
SAI1_RXC	AF16	NVCC_SAI1	GPIO	ALT5	GPIO4.IO[1]	Input with PD
SAI1_RXD0	AG15	NVCC_SAI1	GPIO	ALT5	GPIO4.IO[2]	Input with PD
SAI1_RXD1	AF15	NVCC_SAI1	GPIO	ALT5	GPIO4.IO[3]	Input with PD
SAI1_RXD2	AG17	NVCC_SAI1	GPIO	ALT5	GPIO4.IO[4]	Input with PD

Table 67. i.MX 8M Mini 14 x 14 mm functional contact assignments (continued)

Ball name	Ball	Power group	Ball type	Reset condition		
				Default mode	Default function	Input/Output status
SAI1_RXD3	AF17	NVCC_SAI1	GPIO	ALT5	GPIO4.IO[5]	Input with PD
SAI1_RXD4	AG18	NVCC_SAI1	GPIO	ALT5	GPIO4.IO[6]	Input with PD
SAI1_RXD5	AF18	NVCC_SAI1	GPIO	ALT5	GPIO4.IO[7]	Input with PD
SAI1_RXD6	AG19	NVCC_SAI1	GPIO	ALT5	GPIO4.IO[8]	Input with PD
SAI1_RXD7	AF19	NVCC_SAI1	GPIO	ALT5	GPIO4.IO[9]	Input with PD
SAI1_RXFS	AG16	NVCC_SAI1	GPIO	ALT5	GPIO4.IO[0]	Input with PD
SAI1_TXC	AC18	NVCC_SAI1	GPIO	ALT5	GPIO4.IO[11]	Input with PD
SAI1_TXD0	AG20	NVCC_SAI1	GPIO	ALT5	GPIO4.IO[12]	Input with PD
SAI1_TXD1	AF20	NVCC_SAI1	GPIO	ALT5	GPIO4.IO[13]	Input with PD
SAI1_TXD2	AG21	NVCC_SAI1	GPIO	ALT5	GPIO4.IO[14]	Input with PD
SAI1_TXD3	AF21	NVCC_SAI1	GPIO	ALT5	GPIO4.IO[15]	Input with PD
SAI1_TXD4	AG22	NVCC_SAI1	GPIO	ALT5	GPIO4.IO[16]	Input with PD
SAI1_TXD5	AF22	NVCC_SAI1	GPIO	ALT5	GPIO4.IO[17]	Input with PD
SAI1_TXD6	AG23	NVCC_SAI1	GPIO	ALT5	GPIO4.IO[18]	Input with PD
SAI1_TXD7	AF23	NVCC_SAI1	GPIO	ALT5	GPIO4.IO[19]	Input with PD
SAI1_TXFS	AB19	NVCC_SAI1	GPIO	ALT5	GPIO4.IO[10]	Input with PD
SAI2_MCLK	AD19	NVCC_SAI2	GPIO	ALT5	GPIO4.IO[27]	Input with PD
SAI2_RXC	AB22	NVCC_SAI2	GPIO	ALT5	GPIO4.IO[22]	Input with PD
SAI2_RXD0	AC24	NVCC_SAI2	GPIO	ALT5	GPIO4.IO[23]	Input with PD
SAI2_RXFS	AC19	NVCC_SAI2	GPIO	ALT5	GPIO4.IO[21]	Input with PD
SAI2_TXC	AD22	NVCC_SAI2	GPIO	ALT5	GPIO4.IO[25]	Input with PD
SAI2_TXD0	AC22	NVCC_SAI2	GPIO	ALT5	GPIO4.IO[26]	Input with PD
SAI2_TXFS	AD23	NVCC_SAI2	GPIO	ALT5	GPIO4.IO[24]	Input with PD
SAI3_MCLK	AD6	NVCC_SAI3	GPIO	ALT5	GPIO5.IO[2]	Input with PD
SAI3_RXC	AG7	NVCC_SAI3	GPIO	ALT5	GPIO4.IO[29]	Input with PD
SAI3_RXD	AF7	NVCC_SAI3	GPIO	ALT5	GPIO4.IO[30]	Input with PD
SAI3_RXFS	AG8	NVCC_SAI3	GPIO	ALT5	GPIO4.IO[28]	Input with PD
SAI3_TXC	AG6	NVCC_SAI3	GPIO	ALT5	GPIO5.IO[0]	Input with PD
SAI3_TXD	AF6	NVCC_SAI3	GPIO	ALT5	GPIO5.IO[1]	Input with PD
SAI3_TXFS	AC6	NVCC_SAI3	GPIO	ALT5	GPIO4.IO[31]	Input with PD

Table 67. i.MX 8M Mini 14 x 14 mm functional contact assignments (continued)

Ball name	Ball	Power group	Ball type	Reset condition		
				Default mode	Default function	Input/Output status
SAI5_MCLK <sup>3</sup>	AD15	NVCC_SAI5	GPIO	ALT5	GPIO3.IO[25]	Input without PU/PD
SAI5_RXC	AC15	NVCC_SAI5	GPIO	ALT5	GPIO3.IO[20]	Input with PD
SAI5_RXD0	AD18	NVCC_SAI5	GPIO	ALT5	GPIO3.IO[21]	Input with PD
SAI5_RXD1	AC14	NVCC_SAI5	GPIO	ALT5	GPIO3.IO[22]	Input with PD
SAI5_RXD2	AD13	NVCC_SAI5	GPIO	ALT5	GPIO3.IO[23]	Input with PD
SAI5_RXD3	AC13	NVCC_SAI5	GPIO	ALT5	GPIO3.IO[24]	Input with PD
SAI5_RXFS	AB15	NVCC_SAI5	GPIO	ALT5	GPIO3.IO[19]	Input with PD
SD1_CLK	V26	NVCC_SD1	GPIO	ALT5	GPIO2.IO[0]	Input with PD
SD1_CMD	V27	NVCC_SD1	GPIO	ALT5	GPIO2.IO[1]	Input with PD
SD1_DATA0	Y27	NVCC_SD1	GPIO	ALT5	GPIO2.IO[2]	Input with PD
SD1_DATA1	Y26	NVCC_SD1	GPIO	ALT5	GPIO2.IO[3]	Input with PD
SD1_DATA2	T27	NVCC_SD1	GPIO	ALT5	GPIO2.IO[4]	Input with PD
SD1_DATA3	T26	NVCC_SD1	GPIO	ALT5	GPIO2.IO[5]	Input with PD
SD1_DATA4	U27	NVCC_SD1	GPIO	ALT5	GPIO2.IO[6]	Input with PD
SD1_DATA5	U26	NVCC_SD1	GPIO	ALT5	GPIO2.IO[7]	Input with PD
SD1_DATA6	W27	NVCC_SD1	GPIO	ALT5	GPIO2.IO[8]	Input with PD
SD1_DATA7	W26	NVCC_SD1	GPIO	ALT5	GPIO2.IO[9]	Input with PD
SD1_RESET_B	R23	NVCC_SD1	GPIO	ALT5	GPIO2.IO[10]	Input with PD
SD1_STROBE	R24	NVCC_SD1	GPIO	ALT5	GPIO2.IO[11]	Input with PD
SD2_CD_B	AA26	NVCC_SD2	GPIO	ALT5	GPIO2.IO[12]	Input with PD
SD2_CLK	W23	NVCC_SD2	GPIO	ALT5	GPIO2.IO[13]	Input with PD
SD2_CMD	W24	NVCC_SD2	GPIO	ALT5	GPIO2.IO[14]	Input with PD
SD2_DATA0	AB23	NVCC_SD2	GPIO	ALT5	GPIO2.IO[15]	Input with PD
SD2_DATA1	AB24	NVCC_SD2	GPIO	ALT5	GPIO2.IO[16]	Input with PD
SD2_DATA2	V24	NVCC_SD2	GPIO	ALT5	GPIO2.IO[17]	Input with PD
SD2_DATA3	V23	NVCC_SD2	GPIO	ALT5	GPIO2.IO[18]	Input with PD
SD2_RESET_B	AB26	NVCC_SD2	GPIO	ALT5	GPIO2.IO[19]	Input with PD
SD2_WP	AA27	NVCC_SD2	GPIO	ALT5	GPIO2.IO[20]	Input with PD
SPDIF_EXT_CLK	AF8	NVCC_SAI3	GPIO	ALT5	GPIO5.IO[5]	Input with PD
SPDIF_RX	AG9	NVCC_SAI3	GPIO	ALT5	GPIO5.IO[4]	Input with PD

**Table 67. i.MX 8M Mini 14 x 14 mm functional contact assignments (continued)**

Ball name	Ball	Power group	Ball type	Reset condition		
				Default mode	Default function	Input/Output status
SPDIF_TX	AF9	NVCC_SAI3	GPIO	ALT5	GPIO5.IO[3]	Input with PD
TEST_MODE	D26	NVCC_JTAG	GPIO	ALT0	tcu.TEST_MODE	Input with PD
TSENSOR_TEST_OUT	J23	VDD_ANA1_1P8	ANALOG	—	—	Output low
TSENSOR_REST_EXT	J24	VDD_ANA1_1P8	ANALOG	—	—	—
UART1_RXD	E14	NVCC_UART	GPIO	ALT5	GPIO5.IO[22]	Input with PD
UART1_TXD	F13	NVCC_UART	GPIO	ALT5	GPIO5.IO[23]	Input with PD
UART2_RXD	F15	NVCC_UART	GPIO	ALT5	GPIO5.IO[24]	Input with PD
UART2_TXD	E15	NVCC_UART	GPIO	ALT5	GPIO5.IO[25]	Input with PD
UART3_RXD	E18	NVCC_UART	GPIO	ALT5	GPIO5.IO[26]	Input with PD
UART3_TXD	D18	NVCC_UART	GPIO	ALT5	GPIO5.IO[27]	Input with PD
UART4_RXD	F19	NVCC_UART	GPIO	ALT5	GPIO5.IO[28]	Input with PD
UART4_TXD	F18	NVCC_UART	GPIO	ALT5	GPIO5.IO[29]	Input with PD
USB1_DN	A22	VDD_USB_3P3	PHY	—	—	Input
USB1_DP	B22	VDD_USB_3P3	PHY	—	—	Input
USB1_ID	D22	VDD_USB_1P8	PHY	—	—	Input
USB1_TXRTUNE	E19	VDD_USB_1P8	PHY	—	—	—
USB1_VBUS	F22	VDD_USB_3P3	PHY	—	—	—
USB2_DN	A23	VDD_USB_3P3	PHY	—	—	Input
USB2_DP	B23	VDD_USB_3P3	PHY	—	—	Input
USB2_ID	D23	VDD_USB_1P8	PHY	—	—	Input
USB2_TXRTUNE	E22	VDD_USB_1P8	PHY	—	—	—
USB2_VBUS	F23	VDD_USB_3P3	PHY	—	—	—

<sup>1</sup> Works as JTAG Active output when the internal reset is asserted, default is output low. After the internal reset is deasserted, it becomes input with PD.

<sup>2</sup> Works as INT\_BOOT output when the internal reset is asserted, default is output high. After the internal reset is deasserted, it becomes input with PU.

<sup>3</sup> Works as TESTER\_ACK input when the internal reset is asserted, default is input without PU/PD. After the internal reset is deasserted, it becomes input with PD.

### 5.1.3 i.MX 8M Mini 14 x 14 mm 0.5 mm pitch ball map

Table 68 shows the i.MX 8M Mini 14 x 14 mm 0.5 mm pitch ball map.



Table 68. 14 x 14 mm, 0.5 mm pitch ball map (continued)

	1	2	3	4	5	6	7	8	9	10	11	12	13	14	15	16	17	18	19	20	21	22	23	24	25	26	27
P	N	M	L	K	J	H																					
DRAM_VREF	DRAM_AC26	DRAM_AC16	DRAM_AC05	DRAM_DQ13	DRAM_DQ10	DRAM_DQS1_N																					
DRAM_ZN	DRAM_AC19	DRAM_AC17	DRAM_AC04	DRAM_DQ12	DRAM_DQ11	VSS																					
VSS	VSS			VSS	VSS																						
VDD_DRAM_PLL_1P8	DRAM_AC12			DRAM_AC02	DRAM_AC03																						
	DRAM_AC13			DRAM_AC14	DRAM_AC07																						
	DRAM_AC15			DRAM_AC09	DRAM_AC08																						
NVCC_DRAM	VSS			VSS	VSS																						
	NVCC_DRAM			NVCC_DRAM																							
VDD_DRAM_PLL_0P8	NVCC_DRAM	NVCC_DRAM	NVCC_DRAM	NVCC_DRAM																							
	VDD_DRAM		VDD_DRAM		VDD_DRAM	NVCC_ECSP1																					
	VDD_VPU		VDD_VPU		VDD_VPU																						
VDD_GPU	VSS	VSS	VSS	VDD_VPU	NVCC_UART																						
	VDD_SOC	VDD_VPU	VDD_VPU	VDD_VPU	PVCC2_1P8	VDD_MIPI_1P8																					
	VDD_SOC	VDD_VPU	VDD_SOC	VDD_SOC	VDD_MIPI_0P9																						
	VSS	VSS	VSS	VDD_SOC	VDD_MIPI_1P2	VDD_USB_1P8																					
VDD_ARM_PLL_0P8	VSS	VSS	VSS	VDD_SOC	VDD_PCI_0P8																						
	VDD_ANA_0P8		VDD_ANA_0P8		VDD_USB_0P8																						
	VDD_SOC		VDD_SOC		NC_J18	VSS																					
VDD_ANA1_1P8	VDD_24M_XTAL_1P8	NVCC_CLK	NVCC_JTAG	VDD_USB_3P3																							
	VDD_ANA1_1P8			VSS																							
VSS	VSS			VSS	VSS																						
	NAND_ALE			VDD_SNV5_0P8	NVCC_SNV5_1P8																						
NAND_DATA00	NAND_DATA03			NAND_DATA02	TSENSOR_TEST_OUT																						
	NAND_CE0_B			NAND_DATA01	TESENSOR_RES_EXT																						
VSS	VSS			VSS	VSS																						
NAND_READY_B	NAND_DATA07	NAND_DATA04	NAND_DATA05	NAND_DATA06	CLKOUT2	CLKOUT1																					
NAND_CE1_B	NAND_RE_B	NAND_CE2_B	NAND_CE3_B	NAND_CLE	CLKIN2	CLKIN1																					

Table 68. 14 x 14 mm, 0.5 mm pitch ball map (continued)

AB	AA	Y	W	V	U	T	R
DRAM_DM2	DRAM_DQS2_P	DRAM_DQS2_N	DRAM_DQ18	DRAM_DQ21	DRAM_AC25	DRAM_AC34	DRAM_RESET_N
DRAM_DQ16	DRAM_DQ17	VSS	DRAM_DQ19	DRAM_DQ20	DRAM_AC24	DRAM_AC35	DRAM_ALERT_N
VSS			VSS	VSS			VSS
DRAM_AC20			DRAM_AC22	DRAM_AC23			DRAM_AC32
DRAM_AC21			DRAM_AC37	DRAM_AC36			DRAM_AC33
DRAM_AC38			DRAM_AC28	DRAM_AC29			DRAM_AC27
	VSS		VSS	VSS			VSS
				NVCC_DRAM			NVCC_DRAM
GPIO1_IO15	VSS			NVCC_DRAM	NVCC_DRAM	NVCC_DRAM	NVCC_DRAM
GPIO1_IO12	VSS	NVCC_SAI3	VDD_DRAM		VDD_DRAM		VDD_DRAM
			VDD_GPU		VDD_GPU		VDD_GPU
			NVCC_GPIO1	VDD_GPU	VSS	VSS	VSS
PVCC0_1P8	VSS	VSS	VDD_ARM	VDD_ARM	VDD_ARM	VDD_ARM	VDD_ARM
	VDD_ANA0_1P8		VDD_ARM			VDD_ARM	
SAI5_RXFS	VSS	VDD_ANA0_1P8	VDD_ARM	VDD_ARM	VDD_ARM	VDD_ARM	VDD_ARM
			VDD_ARM	VDD_ARM	VSS	VSS	VSS
			NVCC_SAI5		VDD_SOC		VDD_SOC
SAI1_MCLK	VSS	VSS	NVCC_SAI1		VDD_SOC		VDD_SOC
SAI1_TXFS	VSS			NVCC_SAI2	NVCC_NAND	PVCC1_1P8	VDD_ARM_PLL_1P8
				NVCC_SD1			VSS
	VSS		VSS	VSS			VSS
SAI2_RXC			NVCC_ENET	NVCC_SD2			NAND_DQS
SD2_DATA0			SD2_CLK	SD2_DATA3			SD1_RESET_B
SD2_DATA1			SD2_CMD	SD2_DATA2			SD1_STROBE
VSS			VSS	VSS			VSS
SD2_RESET_B	SD2_CD_B	SD1_DATA1	SD1_DATA7	SD1_CLK	SD1_DATA5	SD1_DATA3	NAND_WE_B
ENET_MDIO	SD2_WP	SD1_DATA0	SD1_DATA6	SD1_CMD	SD1_DATA4	SD1_DATA2	NAND_WP_B

Table 68. 14 x 14 mm, 0.5 mm pitch ball map (continued)

	1	2	3	4	5	6	7	8	9	10	11	12	13	14	15	16	17	18	19	20	21	22	23	24	25	26	27
<b>AG</b>	VSS	DRAM_DQS3_P	DRAM_DQ30	DRAM_DM3	DRAM_DQ24	SAI3_TXC	SAI3_RXC	SAI3_RXFS	SPDIF_RX	GPIO1_IO08	GPIO1_IO06	GPIO1_IO04	GPIO1_IO02	GPIO1_IO00	SAI1_RXD0	SAI1_RXFS	SAI1_RXD2	SAI1_RXD4	SAI1_RXD6	SAI1_TXD0	SAI1_TXD2	SAI1_TXD4	SAI1_TXD6	ENET_TXC	ENET_TD2	ENET_TD0	VSS
<b>AF</b>	DRAM_DQ29	DRAM_DQS3_N	VSS	DRAM_DQ31	DRAM_DQ25	SAI3_TXD	SAI3_RXD	SPDIF_EXT_CLK	SPDIF_TX	GPIO1_IO09	GPIO1_IO07	GPIO1_IO05	GPIO1_IO03	GPIO1_IO01	SAI1_RXD1	SAI1_RXC	SAI1_RXD3	SAI1_RXD5	SAI1_RXD7	SAI1_TXD1	SAI1_TXD3	SAI1_TXD5	SAI1_TXD7	ENET_TX_CTL	ENET_TD3	ENET_TD1	ENET_RX_CTL
<b>AE</b>	DRAM_DQ28	VSS			VSS	VSS			VSS	VSS			VSS	VSS	VSS			VSS	VSS			VSS	VSS			ENET_RXC	ENET_RD0
<b>AD</b>	DRAM_DQ27	DRAM_DQ26			DRAM_AC31	SAI3_MCLK				GPIO1_IO13			SAI5_RXD2		SAI5_MCLK			SAI5_RXD0	SAI2_MCLK			SAI2_TXC	SAI2_TXFS			ENET_RD2	ENET_RD1
<b>AC</b>	DRAM_DQ22	DRAM_DQ23	VSS	DRAM_AC30		SAI3_TXFS			GPIO1_IO14	GPIO1_IO11			SAI5_RXD3	SAI5_RXD1	SAI5_RXC			SAI1_TXC	SAI2_RXFS			SAI2_TXD0		SAI2_RXD0	VSS	ENENT_RD3	ENET_MDC

## 5.2 DDR pin function list

Table 69 shows the DDR pin function list.

Table 69. DDR pin function list

Ball name	LPDDR4	DDR4	DDR3/3L
DRAM_DQS0_P	DQS0_t_A	DQSL_t_A	DQSL_A
DRAM_DQS0_N	DQS0_c_A	DQSL_c_A	DQSL#_A
DRAM_DM0	DMI0_A	DML_n_A / DBIL_n_A	DML_A
DRAM_DQ00	DQ0_A	DQL0_A	DQL0_A
DRAM_DQ01	DQ1_A	DQL1_A	DQL1_A
DRAM_DQ02	DQ2_A	DQL2_A	DQL2_A
DRAM_DQ03	DQ3_A	DQL3_A	DQL3_A
DRAM_DQ04	DQ4_A	DQL4_A	DQL4_A
DRAM_DQ05	DQ5_A	DQL5_A	DQL5_A

Table 69. DDR pin function list (continued)

DRAM_DQ06	DQ6_A	DQL6_A	DQL6_A
DRAM_DQ07	DQ7_A	DQL7_A	DQL7_A
DRAM_DQS1_P	DQS1_t_A	DQSU_t_A	DQSU_A
DRAM_DQS1_N	DQS1_c_A	DQSU_c_A	DQSU#_A
DRAM_DM1	DMI1_A	DMU_n_A / DBIU_n_A	DMU_A
DRAM_DQ08	DQ08_A	DQU0_A	DQU0_A
DRAM_DQ09	DQ09_A	DQU1_A	DQU1_A
DRAM_DQ10	DQ10_A	DQU2_A	DQU2_A
DRAM_DQ11	DQ11_A	DQU3_A	DQU3_A
DRAM_DQ12	DQ12_A	DQU4_A	DQU4_A
DRAM_DQ13	DQ13_A	DQU5_A	DQU5_A
DRAM_DQ14	DQ14_A	DQU6_A	DQU6_A
DRAM_DQ15	DQ15_A	DQU7_A	DQU7_A
DRAM_DQS2_P	DQS0_t_B	DQSL_t_B	DQSL_B
DRAM_DQS2_N	DQS0_c_B	DQSL_c_B	DQSL#_B
DRAM_DM2	DMI0_B	DML_n_B / DBIL_n_B	DML_B
DRAM_DQ16	DQ0_B	DQL0_B	DQL0_B
DRAM_DQ17	DQ1_B	DQL1_B	DQL1_B
DRAM_DQ18	DQ2_B	DQL2_B	DQL2_B
DRAM_DQ19	DQ3_B	DQL3_B	DQL3_B
DRAM_DQ20	DQ4_B	DQL4_B	DQL4_B
DRAM_DQ20	DQ4_B	DQL4_B	DQL4_B
DRAM_DQ21	DQ5_B	DQL5_B	DQL5_B
DRAM_DQ22	DQ6_B	DQL6_B	DQL6_B
DRAM_DQ23	DQ7_B	DQL7_B	DQL7_B
DRAM_DQS3_P	DQS1_t_B	DQSU_t_B	DQSU_B
DRAM_DQS3_N	DQS1_c_B	DQSU_c_B	DQSU#_B
DRAM_DM3	DMI1_B	DMU_n_B / DBIU_n_B	DMU_B
DRAM_DQ24	DQ08_B	DQU0_B	DQU0_B
DRAM_DQ25	DQ09_B	DQU1_B	DQU1_B
DRAM_DQ26	DQ10_B	DQU2_B	DQU2_B
DRAM_DQ27	DQ11_B	DQU3_B	DQU3_B
DRAM_DQ28	DQ12_B	DQU4_B	DQU4_B
DRAM_DQ29	DQ13_B	DQU5_B	DQU5_B

**Table 69. DDR pin function list (continued)**

DRAM_DQ30	DQ14_B	DQU6_B	DQU6_B
DRAM_DQ31	DQ15_B	DQU7_B	DQU7_B
DRAM_RESET_N	RESET_N	RESET_n	RESET#
DRAM_ALERT_N	MTEST1	ALERT_n / MTEST1	MTEST1
DRAM_AC00	CKE0_A	CKE0	CKE0
DRAM_AC01	CKE1_A	CKE1	CKE1
DRAM_AC02	CS0_A	CS0_n	CS0#
DRAM_AC03	CS1_A	C0	—
DRAM_AC04	CK_t_A	BG0	BA2
DRAM_AC05	CK_c_A	BG1	A14
DRAM_AC06	—	ACT_n	A15
DRAM_AC07	—	A9	A9
DRAM_AC08	CA0_A	A12	A12 / BC#
DRAM_AC09	CA1_A	A11	A11
DRAM_AC10	CA2_A	A7	A7
DRAM_AC11	CA3_A	A8	A8
DRAM_AC12	CA4_A	A6	A6
DRAM_AC13	CA5_A	A5	A5
DRAM_AC14	—	A4	A4
DRAM_AC15	—	A3	A3
DRAM_AC16	—	CK_t_A	CK_A
DRAM_AC17	—	CK_c_A	CK#_A
DRAM_AC19	MTEST	MTEST	MTEST
DRAM_AC20	CKE0_B	CK_t_B	CK_B
DRAM_AC21	CKE1_B	CK_c_B	CK#_B
DRAM_AC22	CS1_B	—	—
DRAM_AC23	CS0_B	—	—
DRAM_AC24	CK_t_B	A2	A2
DRAM_AC25	CK_c_B	A1	A1
DRAM_AC26	—	BA1	BA1
DRAM_AC27	—	PARITY	—
DRAM_AC28	CA0_B	A13	A13
DRAM_AC29	CA1_B	BA0	BA0
DRAM_AC30	CA2_B	A10 / AP	A10 / AP

Table 69. DDR pin function list (continued)

DRAM_AC31	CA3_B	A0	A0
DRAM_AC32	CA4_B	C2	—
DRAM_AC33	CA5_B	CAS_n / A15	CAS#
DRAM_AC34	—	WE_n / A14	WE#
DRAM_AC35	—	RAS_n / A16	RAS#
DRAM_AC36	—	ODT0	ODT0
DRAM_AC37	—	ODT1	ODT1
DRAM_AC38	—	CS1_n	CS1#
DRAM_ZN	ZQ	ZQ	ZQ
DRAM_VREF	VREF	VREF	VREF

## 6 Revision history

Table 70 provides a revision history for this data sheet.

**Table 70. Revision history**

Rev. number	Date	Substantive change(s)
Rev. 2	11/2022	<ul style="list-style-type: none"> <li>Updated Temperature Sensor Accuracy and TMU Sensing Temperature range in the Table 10, "Operating ranges".</li> <li>Added Note for the Figure 3, "The power-up sequence".</li> <li>Added Note for the Figure 4, "The power-down sequence".</li> <li>Updated the driver level and ESR values in the Table 20, "Crystal specifications".</li> <li>Updated Section 3.4.2, OSC32K.</li> <li>Updated Note1 for Table 55, "Master mode SAI timing (50 MHz)".</li> <li>Updated Note1 for Table 57, "Slave mode SAI timing (50 MHz)".</li> <li>Added Section 3.8.3, DDR SDRAM-specific parameters (LPDDR4 and DDR4) information.</li> <li>Replaced RGMII to RMII in ENET_TD2 Table 37, "ENET signal mapping" comments.</li> <li>Replaced ESCPI to ECSPi in NVCC_ECSPi Table 66, "i.MX 8M Mini 14 x 14 mm supplies contact assignments" remarks.</li> <li>Updated uSDHC Output Delay minimum value from 6.6 to -6.6 in Table 32, "SD3.0/eMMC5.1 (SDR) interface timing specification"</li> <li>Updated USB1_VBUS, USB2_VBUS minimum and typical value in Table 10, "Operating ranges"</li> </ul>
Rev. 1	07/2020	<ul style="list-style-type: none"> <li>Updated the eMMC descriptions in the Table 1, "Features"</li> <li>Updated numbers of SD 3.0 in the Figure 1, "i.MX 8M Mini system block diagram"</li> <li>Added two part numbers and updated the part differentiator in the Table 2, "Orderable part numbers"</li> <li>Updated the part differentiator and Fusing in the Figure 2, "Part number nomenclature—i.MX 8M Mini family of processors"</li> <li>Updated eCSPI, SJC, and uSDHC descriptions in the Table 3, "i.MX 8M Mini modules list"</li> <li>Updated a typo for NVCC_ENET in the Table 4, "Recommended connections for unused power supply rails"</li> <li>Updated the min values and a typo in the Table 7, "Absolute maximum ratings"; removed ESD parameters from the Table 7, "Absolute maximum ratings"</li> <li>Added the Table 8, "Electrostatic discharge and latch up ratings"</li> <li>Added a footnote in the Table 10, "Operating ranges"</li> <li>Added VDD_24M_XTAL_1P8, VDD_ARM_PLL_1P8, and PVCCx_1P8 in the Table 13, "Maximum supply currents"</li> <li>Updated the Table 14, "Chip power in different LP mode"</li> <li>Updated the suspend mode state of VDD_MIPI_0P9 and VDD_MIPI_1P2 in the Table 15, "The power supply states"</li> <li>Updated the maximum values of T1, T2, T4, T5, T6, T7, T8, T9, T10, T11, T12, T13 and minimum value of T3 in the Table 17, "Power-up sequence"</li> <li>Updated the maximum values in the Table 18, "Power-down sequence"</li> <li>Removed the USBx_ID, ONOFF, and POR_B from the Table 23, "Additional leakage parameters"</li> <li>Added GPIO1_09, I2C2_SCL, and I2C2_SDA in the Table 37, "ENET signal mapping"</li> <li>Removed 0x2 from the Section 3.9.10.1.1, SDR mode with FlexSPIn_MCR0[RXCLKSRC] = 0x0, 0x1 and Section 3.9.10.1.3, DDR mode with FlexSPIn_MCR0[RXCLKSRC] = 0x0, 0x1</li> <li>Updated the parameters of GPIO1_IO00, GPIO1_IO01, GPIO1_IO05, GPIO1_IO09, and SAI5_MCLK in the Table 67, "i.MX 8M Mini 14 x 14 mm functional contact assignments"</li> <li>Fixed typos in the Table 68, "14 x 14 mm, 0.5 mm pitch ball map"</li> </ul>
Rev. 0.2	04/2019	<ul style="list-style-type: none"> <li>Updated numbers of eMMC and FlexSPI in the Figure 1, "i.MX 8M Mini system block diagram"</li> <li>Updated the descriptions about USB and uSDHC in the Table 3, "i.MX 8M Mini modules list"</li> <li>Updated the comment of VDD_VPU and the LPDDR4 maximum value of NVCC_DRAM in the Table 10, "Operating ranges"</li> </ul>

Table 70. Revision history (continued)

Rev. number	Date	Substantive change(s)
Rev. 0.1	02/2019	• Updated the SNVS states in the <a href="#">Table 15, "The power supply states"</a>
Rev. 0	02/2019	• Initial version



## How to Reach Us:

### Home Page:

[nxp.com](http://nxp.com)

### Web Support:

[nxp.com/support](http://nxp.com/support)

Information in this document is provided solely to enable system and software implementers to use NXP products. There are no express or implied copyright licenses granted hereunder to design or fabricate any integrated circuits based on the information in this document. NXP reserves the right to make changes without further notice to any products herein.

NXP makes no warranty, representation, or guarantee regarding the suitability of its products for any particular purpose, nor does NXP assume any liability arising out of the application or use of any product or circuit, and specifically disclaims any and all liability, including without limitation consequential or incidental damages. "Typical" parameters that may be provided in NXP data sheets and/or specifications can and do vary in different applications, and actual performance may vary over time. All operating parameters, including "typicals" must be validated for each customer application by customer, customer's technical experts. NXP does not convey any license under its patent rights nor the rights of others. NXP sells products pursuant to standard terms and conditions of sale, which can be found at the following address: [nxp.com/SalesTermsandConditions](http://nxp.com/SalesTermsandConditions).

While NXP has implemented advanced security features, all products may be subject to unidentified vulnerabilities. Customers are responsible for the design and operation of their applications and products to reduce the effect of these vulnerabilities on customer's applications and products, and NXP accepts no liability for any vulnerability that is discovered. Customers should implement appropriate design and operating safeguards to minimize the risks associated with their applications and products.

NXP, the NXP logo, NXP SECURE CONNECTIONS FOR A SMARTER WORLD, COOLFLUX, EMBRACE, GREENCHIP, HITAG, I2C BUS, ICODE, JCOP, LIFE VIBES, MIFARE, MIFARE CLASSIC, MIFARE DESFire, MIFARE PLUS, MIFARE FLEX, MANTIS, MIFARE ULTRALIGHT, MIFARE4MOBILE, MIGLO, NTAG, ROADLINK, SMARTLX, SMARTMX, STARPLUG, TOPFET, TRENCHMOS, UCODE, Freescale, the Freescale logo, Altivec, C-5, CodeTEST, CodeWarrior, ColdFire, ColdFire+, C-Ware, the Energy Efficient Solutions logo, Kinetis, Layerscape, MagniV, mobileGT, PEG, PowerQUICC, Processor Expert, QorIQ, QorIQ Qonverge, Ready Play, SafeAssure, the SafeAssure logo, StarCore, StarCore, Symphony, VortiQa, Vybrid, Airfast, BeeKit, BeeStack, CoreNet, Flexis, MXC, Platform in a Package, QUICC Engine, SMARTMOS, Tower, TurboLink, UMEMS, EdgeScale, EdgeLock, eIQ, and Immersive3D are trademarks of NXP B.V. All other product or service names are the property of their respective owners. AMBA, Arm, Arm7, Arm7TDMI, Arm9, Arm11, Artisan, big.LITTLE, Cordio, CoreLink, CoreSight, Cortex, DesignStart, DynamIQ, Jazelle, Keil, Mali, Mbed, Mbed Enabled, NEON, POP, RealView, SecurCore, Socrates, Thumb, TrustZone, ULINK, ULINK2, ULINK-ME, ULINK-PLUS, ULINKpro,  $\mu$ Vision, Versatile are trademarks or registered trademarks of Arm Limited (or its subsidiaries) in the US and/or elsewhere. The related technology may be protected by any or all of patents, copyrights, designs and trade secrets. All rights reserved. Oracle and Java are registered trademarks of Oracle and/or its affiliates. The Power Architecture and Power.org word marks and the Power and Power.org logos and related marks are trademarks and service marks licensed by Power.org.

© 2019-2022 NXP B.V.

Document Number: IMX8MMCEC

Rev. 2

11/2022

arm



## Looking for pricing, stock, or lifecycle information?

Click below to explore more details on WIN SOURCE:

- ⊖ [View MIMX8MM6DRTLZAA on WIN SOURCE](#)
- ⊖ [NXP / Nexperia Information](#)

## Optimize Your Supply Chain with WIN SOURCE Solutions

- ✓ Global Sourcing Solution
- ✓ Obsolete Management
- ✓ Cost Control Management
- ✓ Shortage Management
- ✓ Alternative Solution
- ✓ Excess Inventory Management