



THE DATASHEET OF MID400M



AC Line Monitor Logic-Out Device

MID400M

Description

The MID400M is an optically isolated AC line-to-logic interface device. It is packaged in an 8-lead plastic DIP. The AC line voltage is monitored by two back-to-back GaAs LED diodes in series with an external resistor. A high gain detector circuit senses the LED current and drives the output gate to a logic low condition.

The MID400M has been designed solely for the use as an AC line monitor. It is recommended for use in any AC-to-DC control application where excellent optical isolation, solid state reliability, TTL compatibility, small size, low power, and low frequency operations are required.

Features

- Direct Operation from any Line Voltage with the Use of an External Resistor
- Externally Adjustable Time Delay
- Externally Adjustable AC Voltage Sensing Level
- Logic Level Compatibility
- Safety and Regulatory Approvals:
 - ◆ UL1577, 5,000 VAC_{RMS} for 1 Minute
 - ◆ DIN-EN/IEC60747-5-5, 890 V Peak Working Insulation Voltage

Applications

- Monitoring of the AC/DC “Line-down” Condition
- “Closed-loop” Interface between Electromechanical Elements such as Solenoids, Relay Contacts, Small Motors, and Microprocessors
- Time Delay Isolation Switch

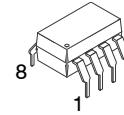

PDIP8 6.6x3.81, 2.54P
CASE 646BW

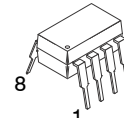

PDIP8 9.655x6.6, 2.54P
CASE 646CQ

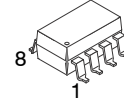

PDIP8 GW
CASE 709AC

MARKING DIAGRAM

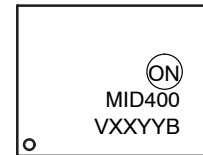

- MID400 = Specific Device Code
- V = DIN EN/IEC60747-5-5 Option (only appears on component ordered with this option)
- XX = Two-Digit Year Code, e.g., “06”
- YY = Digit Work Week, Ranging from “01” to “53”
- B = Assembly Package Code

FUNCTIONAL SCHEMATIC

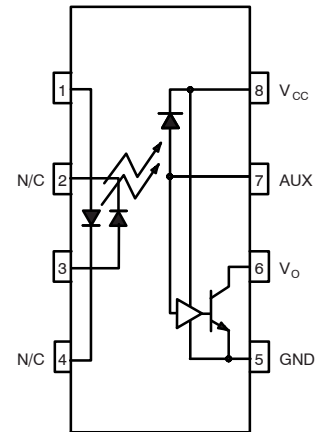

ORDERING INFORMATION

See detailed ordering and shipping information on page 10 of this data sheet.

MID400M

SAFETY AND INSULATION RATINGS (As per DIN EN/IEC 60747-5-5, this optocoupler is suitable for “safe electrical insulation” only within the safety limit data. Compliance with the safety ratings shall be ensured by means of protective circuits.)

Parameter		Characteristics
Installation Classifications per DIN VDE 0110/1.89 Table 1, For Rated Mains Voltage	<150 V _{RMS}	I-IV
	<300 V _{RMS}	I-IV
	<450 V _{RMS}	I-III
	<600 V _{RMS}	I-III
Climatic Classification		40/100/21
Pollution Degree (DIN VDE 0110/1.89)		2
Comparative Tracking Index		175

Symbol	Parameter	Value	Unit
V _{PR}	Input-to-Output Test Voltage, Method A, V _{IORM} × 1.6 = V _{PR} , Type and Sample Test with t _m = 10 s, Partial Discharge < 5 pC	1,335	V _{peak}
	Input-to-Output Test Voltage, Method B, V _{IORM} × 1.875 = V _{PR} , 100% Production Test with t _m = 1 s, Partial Discharge < 5 pC	1,669	V _{peak}
V _{IORM}	Maximum Working Insulation Voltage	890	V _{peak}
V _{IOTM}	Highest Allowable Over-Voltage	6,000	V _{peak}
	External Creepage	≥8.0	mm
	External Clearance	≥7.4	mm
	External Clearance (for Option TV, 0.4" Lead Spacing)	≥10.16	mm
DTI	Distance Through Insulation (Insulation Thickness)	≥0.5	mm
T _S	Case Temperature (Note 1)	150	°C
I _{S,INPUT}	Input Current (Note 1)	200	mA
P _{S,OUTPUT}	Output Power (Duty Factor ≤ 2.7%) (Note 1)	300	mW
R _{IO}	Insulation Resistance at T _S , V _{IO} = 500 V (Note 1)	>10 ⁹	Ω

1. Safety limit value – maximum values allowed in the event of a failure.

MID400M

ABSOLUTE MAXIMUM RATINGS

Symbol	Parameter	Value	Unit
T _{STG}	Storage Temperature	-55 to +125	°C
T _{OPR}	Operating Temperature	-40 to +85	°C
T _J	Junction Temperature	-55 to +100	°C
T _{SOL}	Lead Solder Temperature	260 for 10 seconds	°C
P _D	Total Device Power Dissipation @ T _A = 25°C	115	mW
	Derate Above 70°C	4	mW/°C

EMITTER

	RMS Current	25	mA
	DC Current	±30	mA
P _{D(EMITTER)}	LED Power Dissipation @ T _A = 25°C	45	mW
	Derate Above 70°C	2	mW/°C

DETECTOR

I _{OL}	Low Level Output Current	20	mA
V _{OH}	High Level Output Voltage	7	V
V _{CC}	Supply Voltage	7	V
P _{D(DETECTOR)}	Detector Power Dissipation @ T _A = 25°C	70	mW
	Derate Above 70°C	2	mW/°C

Stresses exceeding those listed in the Maximum Ratings table may damage the device. If any of these limits are exceeded, device functionality should not be assumed, damage may occur and reliability may be affected.

MID400M

ELECTRICAL CHARACTERISTICS (0°C to 70°C Free Air Temperature unless otherwise specified)

Symbol	Parameter	Test Conditions	Min	Typ	Max	Unit
--------	-----------	-----------------	-----	-----	-----	------

INDIVIDUAL COMPONENT CHARACTERISTICS

EMITTER						
V_F	Input Forward Voltage	$I_{IN(DC)} = \pm 30 \text{ mA}$	-	-	1.5	V
DETECTOR						
I_{CCL}	Logic Low Output Supply Current	$I_{IN(RMS)} = 4.0 \text{ mA}$, $V_O = \text{Open}$, $V_{CC} = 5.5 \text{ V}$, $24 \text{ V} \leq V_{IN(ON_RMS)} \leq 240 \text{ V}$	-	-	3.0	mA
I_{CCH}	Logic High Output Supply Current	$I_{IN(RMS)} = 0.15 \text{ mA}$, $V_{CC} = 5.5 \text{ V}$, $V_{IN(OFF_RMS)} \geq 5.5 \text{ V}$	-	-	0.8	mA

TRANSFER CHARACTERISTICS

DC CHARACTERISTICS						
V_{OL}	Logic Low Output Current	$I_{IN} = I_{IN(ON_RMS)}$, $I_O = 16 \text{ mA}$, $V_{CC} = 4.5 \text{ V}$, $24 \text{ V} \leq V_{IN(ON_RMS)} \leq 240 \text{ V}$	-	0.18	0.40	V
I_{OH}	Logic High Output Current	$I_{IN(RMS)} = 0.15 \text{ mA}$, $V_O = V_{CC} = 5.5 \text{ V}$, $V_{IN(OFF_RMS)} \geq 5.5 \text{ V}$	-	0.02	100	μA
$V_{IN(ON_RMS)}$	On-state RMS Input Voltage	$I_O = 16 \text{ mA}$, $V_O = 0.4 \text{ V}$, $V_{CC} = 4.5 \text{ V}$, $R_{IN} = 22 \text{ k}\Omega$	90	-	-	V
$V_{IN(OFF_RMS)}$	Off-state RMS Input Voltage	$I_O \leq 100 \mu\text{A}$, $V_O = V_{CC} = 5.5 \text{ V}$, $R_{IN} = 22 \text{ k}\Omega$	-	-	5.5	V
$I_{IN(ON_RMS)}$	On-state RMS Input Current	$I_O = 16 \text{ mA}$, $V_O = 0.4 \text{ V}$, $V_{CC} = 4.5 \text{ V}$, $24 \text{ V} \leq V_{IN(ON_RMS)} \leq 240 \text{ V}$	4.0	-	-	mA
$I_{IN(OFF_RMS)}$	Off-state RMS Input Current	$I_O \leq 100 \mu\text{A}$, $V_O = V_{CC} = 5.5 \text{ V}$, $V_{IN(OFF_RMS)} \geq 5.5 \text{ V}$	-	-	0.15	mA
AC CHARACTERISTICS						
t_{ON}	Turn-On Time	$I_{IN(RMS)} = 4.0 \text{ mA}$, $I_O = 16 \text{ mA}$, $V_{CC} = 4.5 \text{ V}$, $R_{IN} = 22 \text{ k}\Omega$ (See figure 3)	-	1.0	-	ms
t_{OFF}	Turn-Off Time		-	1.0	-	ms

ISOLATION CHARACTERISTICS

V_{ISO}	Steady State Isolation Voltage	Relative Humidity $\leq 50\%$, $I_{I-O} \leq 10 \mu\text{A}$, 1 Minute, 60 Hz	5,000	-	-	$V_{AC(RMS)}$
C_{ISO}	Isolation Capacitance	$f = 1 \text{ MHz}$	-	-	2	pF
R_{ISO}	Isolation Resistance	$V_{I-O} = 500 \text{ VDC}$	10^{11}	-	-	Ω

Product parametric performance is indicated in the Electrical Characteristics for the listed test conditions, unless otherwise noted. Product performance may not be indicated by the Electrical Characteristics if operated under different conditions.

APPLICATION INFORMATION

The input of the MID400M consists of two back-to-back LED diodes which will accept and convert alternating currents into light energy. An integrated photo diode-detector amplifier forms the output network. Optical coupling between input and output provides 2500 VAC_{RMS} voltage isolation. A very high current transfer ratio (defined as the ratio of the DC output current and the DC input current) is achieved through the use of high gain amplifier. The detector amplifier circuitry operates from a 5 V DC supply and drives an open collector transistor output. The switching times are intentionally designed to be slow in order to enable the MID400M, when used as an AC line monitor, to respond only to changes in input voltage exceeding many milliseconds. The short period of time during zero-crossing which occurs once every half cycle of the power line is completely ignored. To operate the MID400M, always add a resistor, R_{IN}, in series with the input (as shown in figure 2) to limit the current to the required value. The value of the resistor can be determined by the following equation:

$$R_{IN} = \frac{V_{IN} - V_F}{I_{IN}} \quad (\text{eq. 1})$$

Where,

V_{IN} (RMS) is the input voltage.

V_F is the forward voltage drop across the LED.

I_{IN} (RMS) is the desired input current required to sustain a logic “O” on the output.

PIN DESCRIPTION

Pin Number	Pin Name	Description
1, 3	V _{IN1} , V _{IN2}	Input terminals
2, 4	N/C	No Connect
8	V _{CC}	Supply voltage, output circuit.
7	AUX	Auxiliary terminal. Programmable capacitor input to adjust AC voltage sensing level and time delay.
6	V _O	Output terminal; open collector.
5	GND	Circuit ground potential.

SCHEMATIC DIAGRAM

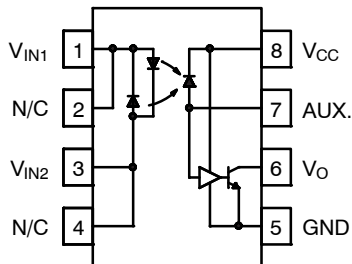

Figure 1. Schematic Diagram

GLOSSARY

Voltages

V_{IN (ON_RMS)}
On-State RMS Input Voltage

The RMS voltage at an input terminal for a specified input current with output conditions applied according to the product specification will cause the output switching element to be sustained in the on-state within one full cycle.

V_{IN (OFF_RMS)}
Off-State RMS Input Voltage

The RMS voltage at an input terminal for a specified input current with output conditions applied according to the product specification will cause the output switching element to be sustained in the off-state within one full cycle.

V_{OL}
Low-Level Output Voltage

The voltage at an output terminal for a specific output current I_{OL}, with input conditions applied according to the product specification will establish a low-level at the output.

V_{OH}
High-Level Output Voltage

The voltage at an output terminal for a specific output current I_{OH}, with input conditions applied according to the product specification will establish a high-level at the output.

V_F
LED Forward Voltage

The voltage developed across the LED when input current I_F is applied to the anode of the LED.

Currents

I_{IN (ON_RMS)}
On-State RMS Input Current

The RMS current flowing into an input with output conditions applied according to the product specification will cause the output switching element to be sustained in the on-state within one full cycle.

I_{IN (OFF_RMS)}
Off-state RMS Input Current

The RMS current flowing into an input with output conditions applied according to the product specification will cause the output switching element to be sustained in the off-state within one full cycle.

I_{OH}
High-Level Output Current

The current flowing into an output with input conditions applied according to the product specification will establish high-level at the output.

MID400M

I_{OL}

Low-Level Output Current

The current flowing into an output with input conditions applied according to the product specification will establish low-level at the output.

I_{CCL}

Supply Current, Output LOW

The current flowing into the V_{CC} supply terminal of a circuit when the output is at a low-level voltage.

I_{CCH}

Supply Current, Output HIGH

The current flowing into the V_{CC} supply terminal of a circuit when the output is at a high-level voltage.

Dynamic Characteristics

t_{ON}

Turn-On Time

The time between the specified reference points on the input and the output voltage waveforms with the output changing from the defined high-level to the defined low-level.

t_{OFF}

Turn-Off Time

The time between the specified reference points on the input and the output voltage waveforms with the output changing from the defined low-level to the defined high-level.

MID400M

TEST CIRCUITS

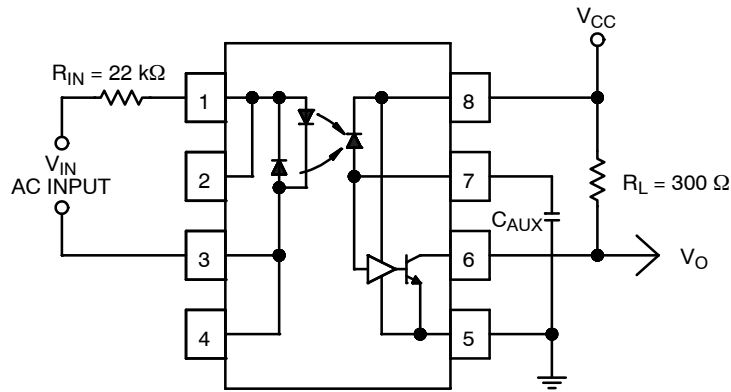

INPUT CURRENT VS. CAPACITANCE, C_{AUX} CIRCUIT

Figure 2. Typical Application Circuit

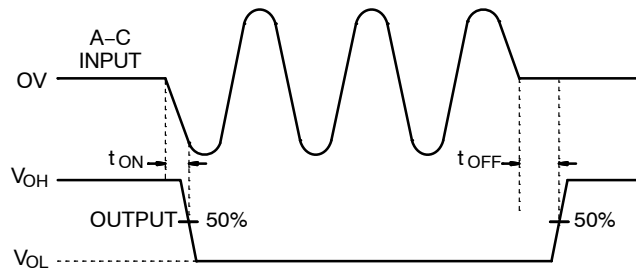

*INPUT TURNS ON AND OFF AT ZERO CROSSING

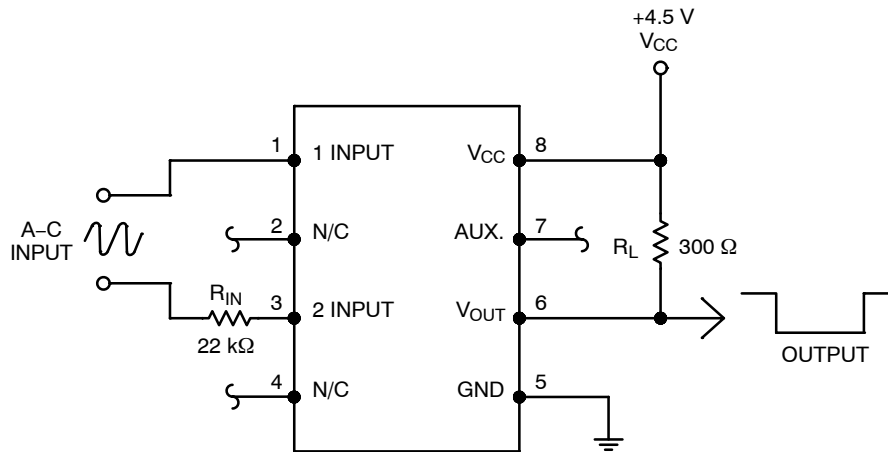

TEST CIRCUIT

Figure 3. MID400M Switching Time

MID400M

TYPICAL PERFORMANCE CURVES

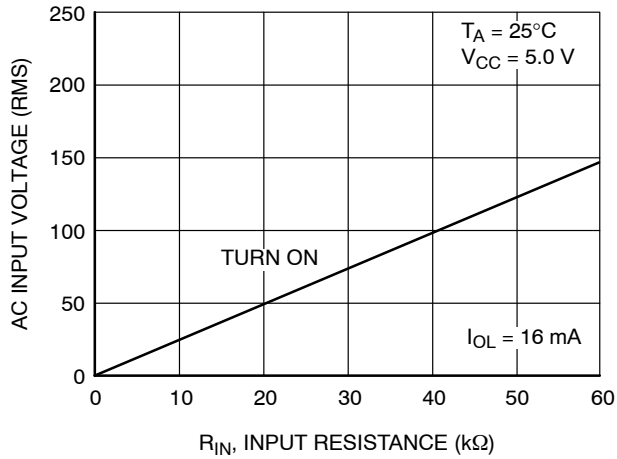

Figure 4. Input Voltage vs. Input Resistance

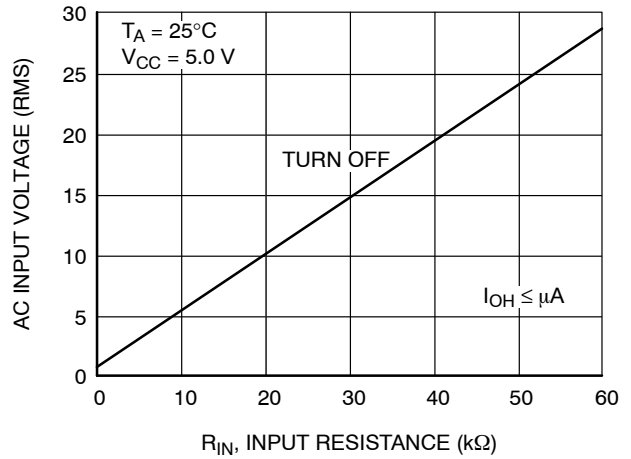

Figure 8. Input Voltage vs. Input Resistance

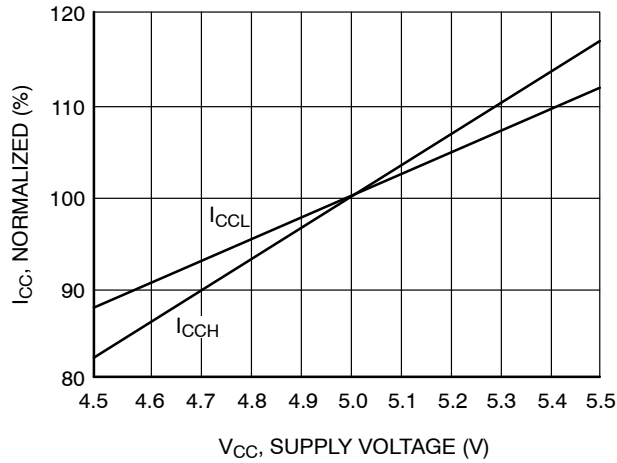

Figure 5. Supply Current vs. Supply Voltage

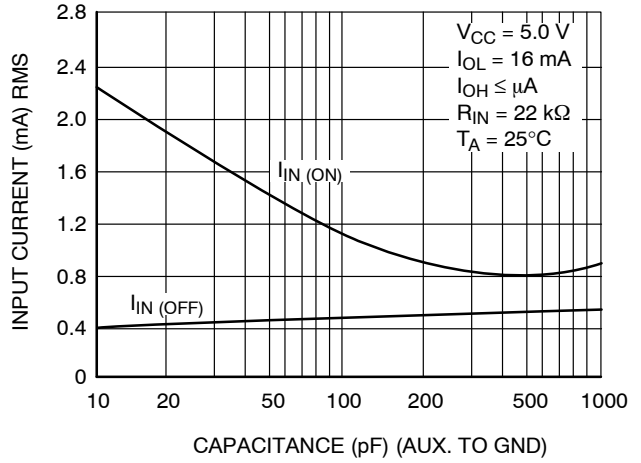

Figure 7. Input Current vs. Capacitance

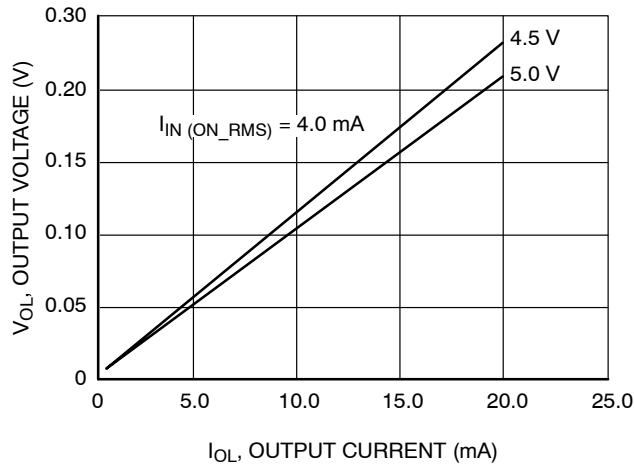
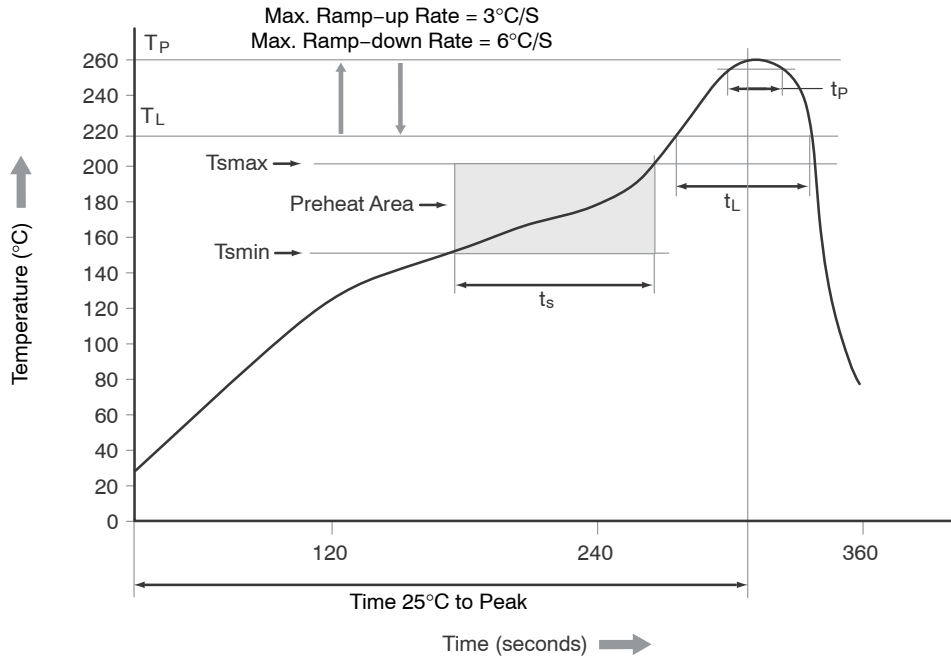

Figure 6. Output Voltage vs. Output Current

MID400M

REFLOW PROFILE



Profile Feature	Pb-Free Assembly Profile
Temperature Minimum (T _{smin})	150°C
Temperature Maximum (T _{smax})	200°C
Time (t _s) from (T _{smin} to T _{smax})	60 to 120 s
Ramp-up Rate (t _L to t _p)	3°C/second maximum
Liquidous Temperature (T _L)	217°C
Time (t _L) Maintained Above (T _L)	60 to 150 s
Peak Body Package Temperature	260°C +0°C / -5°C
Time (t _p) within 5°C of 260°C	30 s
Ramp-down Rate (T _P to T _L)	6°C/s maximum
Time 25°C to Peak Temperature	8 minutes maximum

Figure 9. Reflow Profile

MID400M

ORDERING INFORMATION

Part Number	Package	Shipping†
MID400M	DIP 8-Pin (Pb-Free)	50 / Tube
MID400SM	SMT 8-Pin (Lead Bend) (Pb-Free)	50 / Tube
MID400SDM	SMT 8-Pin (Lead Bend) (Pb-Free)	1,000 / Tape and Reel
MID400VM	DIP 8-Pin, DIN EN/IEC 60747-5-5 Option (Pb-Free)	50 / Tube
MID400SVM	SMT 8-Pin (Lead Bend), DIN EN/IEC 60747-5-5 Option (Pb-Free)	50 / Tube
MID400SDVM	SMT 8-Pin (Lead Bend), DIN EN/IEC 60747-5-5 Option (Pb-Free)	1,000 / Tape and Reel
MID400TVM	DIP 8-Pin, 0.4" Lead Spacing, DIN EN/IEC 60747-5-5 Option (Pb-Free)	50 / Tube

†For information on tape and reel specifications, including part orientation and tape sizes, please refer to our Tape and Reel Packaging Specifications Brochure, BRD8011/D.

MID400M

PACKAGE DIMENSIONS

PDIP8 6.6x3.81, 2.54P
CASE 646BW
ISSUE O

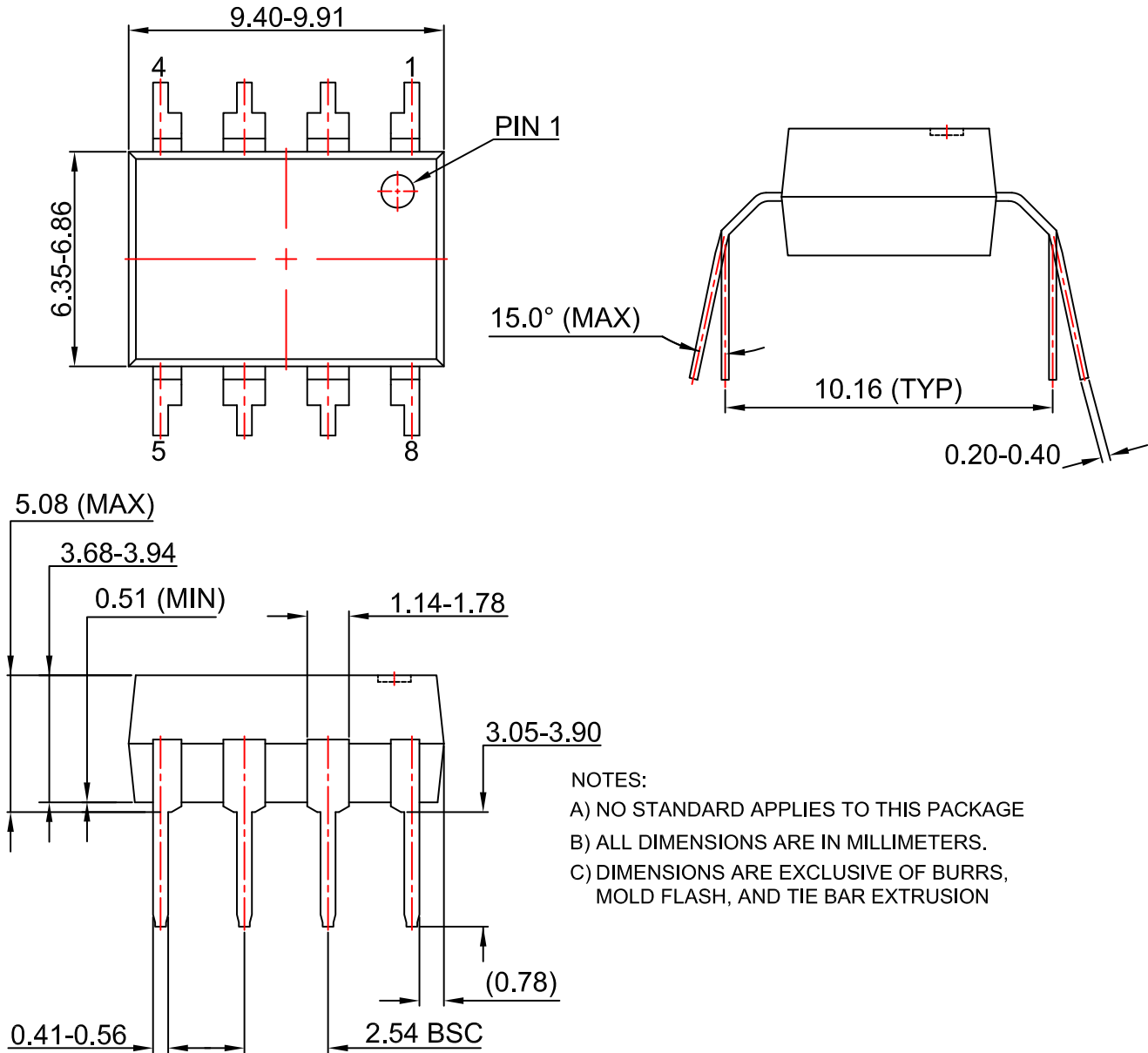

- NOTES:
A) NO STANDARD APPLIES TO THIS PACKAGE
B) ALL DIMENSIONS ARE IN MILLIMETERS.
C) DIMENSIONS ARE EXCLUSIVE OF BURRS,
MOLD FLASH, AND TIE BAR EXTRUSION

MID400M

PACKAGE DIMENSIONS

PDIP8 9.655x6.6, 2.54P
CASE 646CQ
ISSUE O

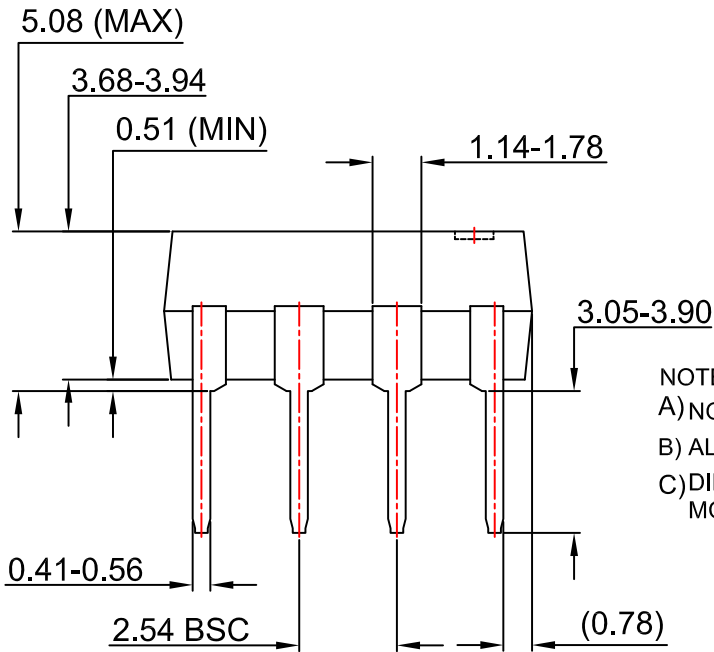
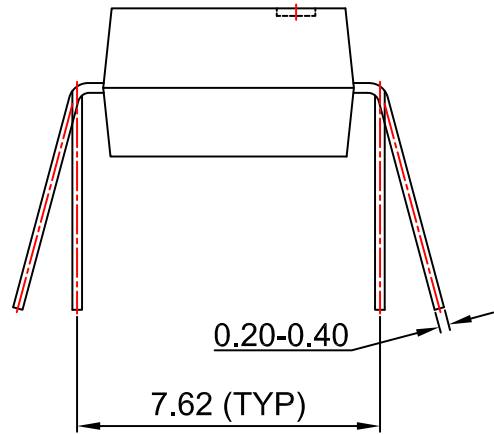
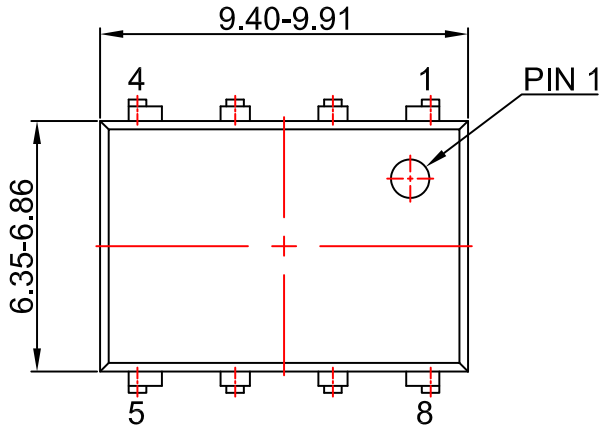

- NOTES:
A) NO STANDARD APPLIES TO THIS PACKAGE
B) ALL DIMENSIONS ARE IN MILLIMETERS.
C) DIMENSIONS ARE EXCLUSIVE OF BURRS, MOLD FLASH, AND TIE BAR EXTRUSION

MID400M

PACKAGE DIMENSIONS

PDIP8 GW
CASE 709AC
ISSUE O

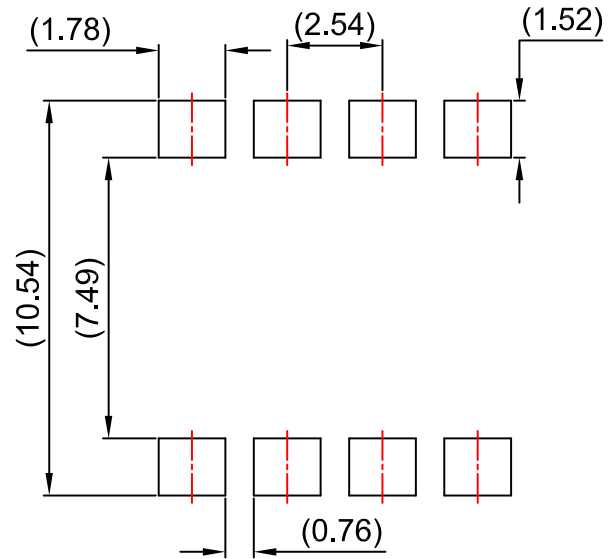
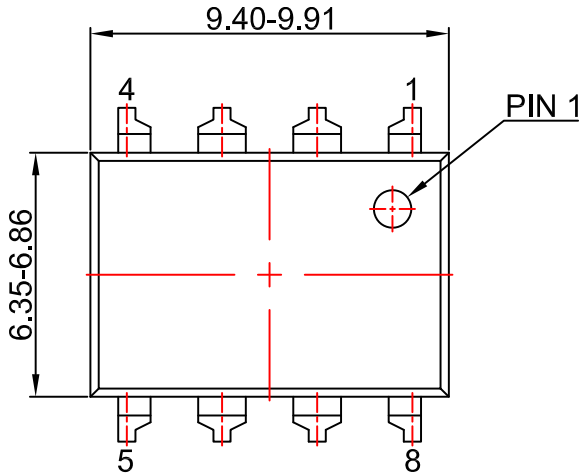

LAND PATTERN RECOMMENDATION

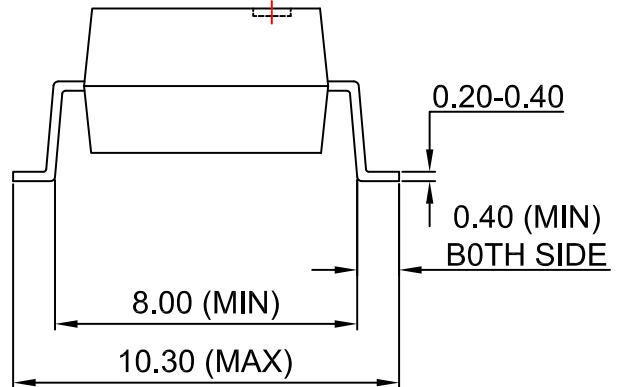
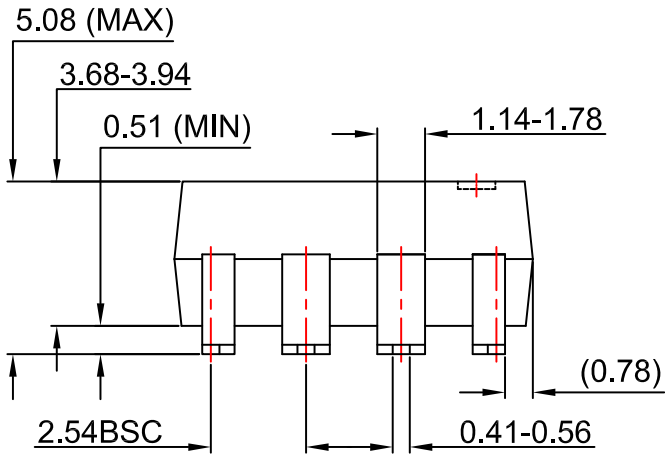

NOTES:

- A) NO STANDARD APPLIES TO THIS PACKAGE
- B) ALL DIMENSIONS ARE IN MILLIMETERS.
- C) DIMENSIONS ARE EXCLUSIVE OF BURRS, MOLD FLASH, AND TIE BAR EXTRUSION

MID400M

onsemi, **Onsemi**, and other names, marks, and brands are registered and/or common law trademarks of Semiconductor Components Industries, LLC dba "**onsemi**" or its affiliates and/or subsidiaries in the United States and/or other countries. **onsemi** owns the rights to a number of patents, trademarks, copyrights, trade secrets, and other intellectual property. A listing of **onsemi**'s product/patent coverage may be accessed at www.onsemi.com/site/pdf/Patent-Marking.pdf. **onsemi** reserves the right to make changes at any time to any products or information herein, without notice. The information herein is provided "as-is" and **onsemi** makes no warranty, representation or guarantee regarding the accuracy of the information, product features, availability, functionality, or suitability of its products for any particular purpose, nor does **onsemi** assume any liability arising out of the application or use of any product or circuit, and specifically disclaims any and all liability, including without limitation special, consequential or incidental damages. Buyer is responsible for its products and applications using **onsemi** products, including compliance with all laws, regulations and safety requirements or standards, regardless of any support or applications information provided by **onsemi**. "Typical" parameters which may be provided in **onsemi** data sheets and/or specifications can and do vary in different applications and actual performance may vary over time. All operating parameters, including "Typicals" must be validated for each customer application by customer's technical experts. **onsemi** does not convey any license under any of its intellectual property rights nor the rights of others. **onsemi** products are not designed, intended, or authorized for use as a critical component in life support systems or any FDA Class 3 medical devices or medical devices with a same or similar classification in a foreign jurisdiction or any devices intended for implantation in the human body. Should Buyer purchase or use **onsemi** products for any such unintended or unauthorized application, Buyer shall indemnify and hold **onsemi** and its officers, employees, subsidiaries, affiliates, and distributors harmless against all claims, costs, damages, and expenses, and reasonable attorney fees arising out of, directly or indirectly, any claim of personal injury or death associated with such unintended or unauthorized use, even if such claim alleges that **onsemi** was negligent regarding the design or manufacture of the part. **onsemi** is an Equal Opportunity/Affirmative Action Employer. This literature is subject to all applicable copyright laws and is not for resale in any manner.

PUBLICATION ORDERING INFORMATION

LITERATURE FULFILLMENT:

Email Requests to: orderlit@onsemi.com

onsemi Website: www.onsemi.com

TECHNICAL SUPPORT

North American Technical Support:

Voice Mail: 1 800-282-9855 Toll Free USA/Canada

Phone: 011 421 33 790 2910

Europe, Middle East and Africa Technical Support:

Phone: 00421 33 790 2910

For additional information, please contact your local Sales Representative

Looking for pricing, stock, or lifecycle information?

Click below to explore more details on WIN SOURCE:

- ⊖ [View MID400M on WIN SOURCE](#)
- ⊖ [ON Semiconductor Information](#)

Optimize Your Supply Chain with WIN SOURCE Solutions

- ✓ Global Sourcing Solution
- ✓ Obsolete Management
- ✓ Cost Control Management
- ✓ Shortage Management
- ✓ Alternative Solution
- ✓ Excess Inventory Management