



**THE DATASHEET OF
CD54HC4538F3A**



CD54HC4538, CD74HC4538, CD54HCT4538, CD74HCT4538

High-Speed CMOS Logic Dual Retriggerable Precision Monostable Multivibrator

Features

- Retriggerable/Resettable Capability
- Trigger and Reset Propagation Delays Independent of R_X , C_X
- Triggering from the Leading or Trailing Edge
- Q and \bar{Q} Buffered Outputs Available
- Separate Resets
- Wide Range of Output Pulse Widths
- Schmitt Trigger Input on A and \bar{B} Inputs
- Retrigger Time is Independent of C_X
- Fanout (Over Temperature Range)
 - Standard Outputs 10 LSTTL Loads
 - Bus Driver Outputs 15 LSTTL Loads
- Wide Operating Temperature Range . . . -55°C to 125°C
- Balanced Propagation Delay and Transition Times
- Significant Power Reduction Compared to LSTTL Logic ICs
- HC Types
 - 2V to 6V Operation
 - High Noise Immunity: $N_{IL} = 30\%$, $N_{IH} = 30\%$ of V_{CC} at $V_{CC} = 5V$
- HCT Types
 - 4.5V to 5.5V Operation
 - Direct LSTTL Input Logic Compatibility, $V_{IL} = 0.8V$ (Max), $V_{IH} = 2V$ (Min)
 - CMOS Input Compatibility, $I_I \leq 1\mu A$ at V_{OL} , V_{OH}

Pinout

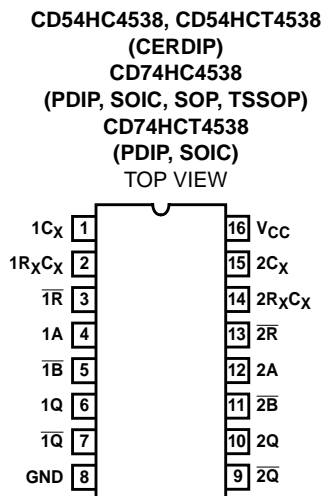

Description

The 'HC4538 and 'HCT4538 are dual retriggerable/resettable monostable precision multivibrators for fixed voltage timing applications. An external resistor (R_X) and an external capacitor (C_X) control the timing and the accuracy for the circuit. Adjustment of R_X and C_X provides a wide range of output pulse widths from the Q and \bar{Q} terminals. The propagation delay from trigger input-to-output transition and the propagation delay from reset input-to-output transition are independent of R_X and C_X .

Leading-edge triggering (A) and trailing edge triggering (\bar{B}) inputs are provided for triggering from either edge of the input pulse. An unused "A" input should be tied to GND and an unused \bar{B} should be tied to V_{CC} . On power up the IC is reset. Unused resets and sections must be terminated. In normal operation the circuit retriggers on the application of each new trigger pulse. To operate in the non-triggerable mode \bar{Q} is connected to \bar{B} when leading edge triggering (A) is used or Q is connected to A when trailing edge triggering (\bar{B}) is used. The period (τ) can be calculated from $\tau = (0.7) R_X C_X$; R_{MIN} is 5k Ω . C_{MIN} is 0pF.

Ordering Information

PART NUMBER	TEMP. RANGE (°C)	PACKAGE
CD54HC4538F3A	-55 to 125	16 Ld CERDIP
CD54HCT4538F3A	-55 to 125	16 Ld CERDIP
CD74HC4538E	-55 to 125	16 Ld PDIP
CD74HC4538M	-55 to 125	16 Ld SOIC
CD74HC4538MT	-55 to 125	16 Ld SOIC
CD74HC4538M96	-55 to 125	16 Ld SOIC
CD74HC4538NSR	-55 to 125	16 Ld SOP
CD74HC4538PW	-55 to 125	16 Ld TSSOP
CD74HC4538PWR	-55 to 125	16 Ld TSSOP
CD74HC4538PWT	-55 to 125	16 Ld TSSOP
CD74HCT4538E	-55 to 125	16 Ld PDIP
CD74HCT4538M	-55 to 125	16 Ld SOIC
CD74HCT4538MT	-55 to 125	16 Ld SOIC
CD74HCT4538M96	-55 to 125	16 Ld SOIC

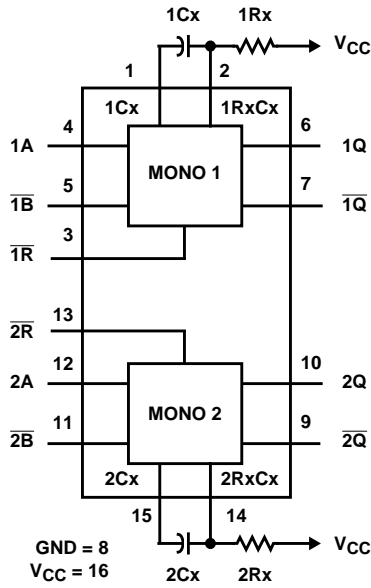

NOTE: When ordering, use the entire part number. The suffixes 96 and R denote tape and reel. The suffix T denotes a small-quantity reel of 250.

Functional Diagram



TRUTH TABLE

INPUTS			OUTPUTS	
\bar{R}	A	\bar{B}	Q	\bar{Q}
L	X	X	L	H
X	H	X	L	H
X	X	L	L	H
H	L	↓	One High Level Pulse	One Low Level Pulse
H	↑	H	One High Level Pulse	One Low Level Pulse

H = High Level, L = Low Level, ↑ = Transition from Low to High,
 ↓ = Transition from High to Low,  One High Level Pulse,
 One Low Level Pulse, X = Irrelevant.

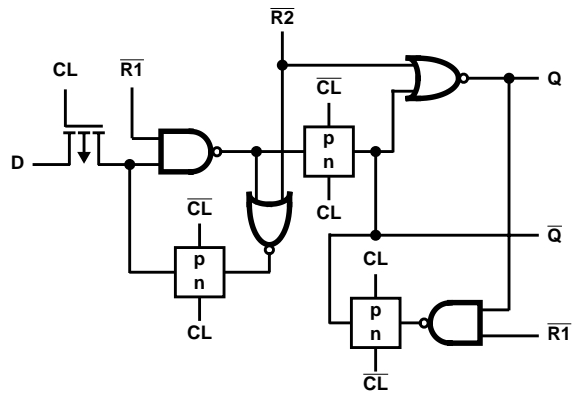

FIGURE 1. FF DETAIL

CD54HC4538, CD74HC4538, CD54HCT4538, CD74HCT4538

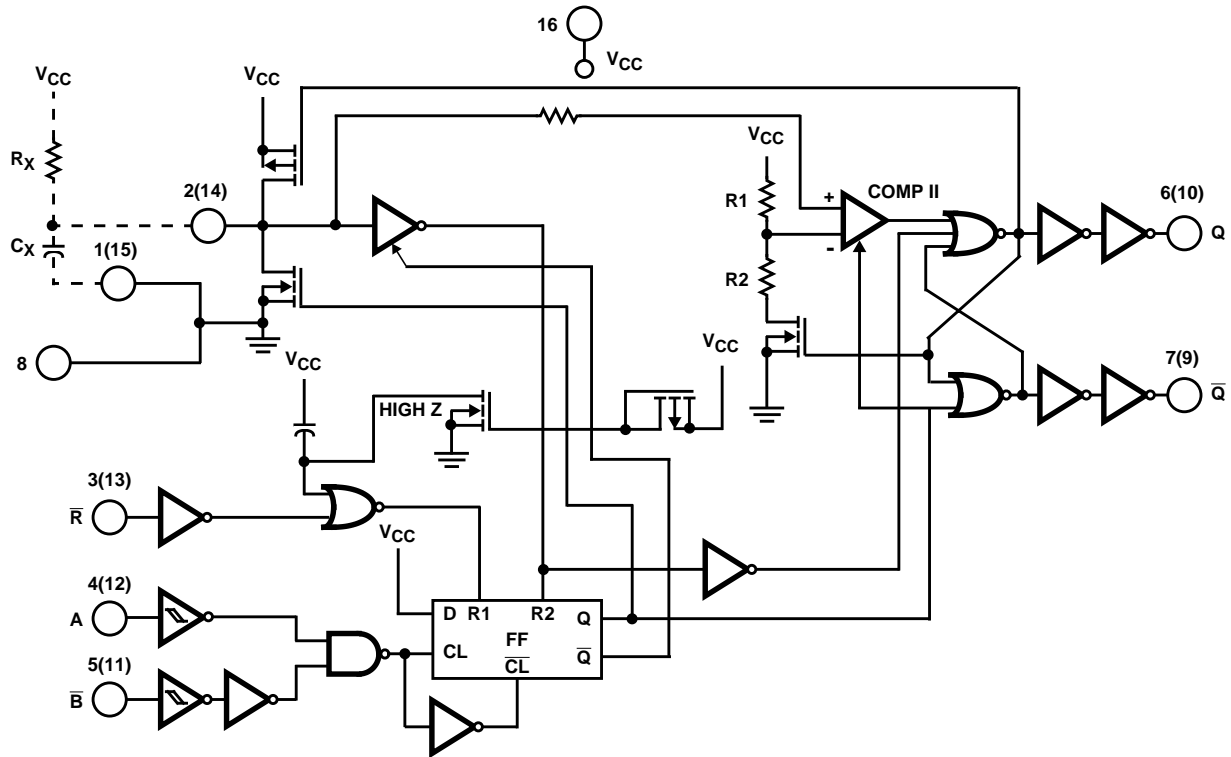

FIGURE 2. LOGIC DIAGRAM (1 MONO)

FUNCTIONAL TERMINAL CONNECTIONS

FUNCTION	V _{CC} TO TERMINAL NUMBER		GND TO TERMINAL NUMBER		INPUT PULSE TO TERMINAL NUMBER		OTHER CONNECTIONS	
	MONO ₁	MONO ₂	MONO ₁	MONO ₂	MONO ₁	MONO ₂	MONO ₁	MONO ₂
Leading-Edge Trigger/Retriggerable	3, 5	11, 13			4	12		
Leading-Edge Trigger/Non-Retriggerable	3	13			4	12	5-7	11-9
Trailing-Edge Trigger/Retriggerable	3	13	4	12	5	11		
Trailing-Edge Trigger/Non-Retriggerable	3	13			5	11	4-6	12-10

NOTES:

1. A retriggerable one-shot multivibrator has an output pulse width which is extended one full time period (T) after application of the last trigger pulse.
2. A non-triggerable one-shot multivibrator has a time period (T) referenced from the application of the first trigger pulse.



FIGURE 3. INPUT PULSE TRAIN

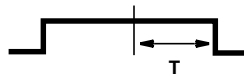

FIGURE 4. RETRIGGERABLE MODE PULSE WIDTH (A MODE)

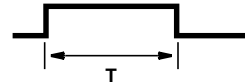

FIGURE 5. NON-RETRIGGERABLE MODE PULSE WIDTH (A MODE)

CD54HC4538, CD74HC4538, CD54HCT4538, CD74HCT4538

Absolute Maximum Ratings

DC Supply Voltage, V_{CC}	-0.5V to 7V
DC Input Diode Current, I_{IK}	
For $V_I < -0.5V$ or $V_I > V_{CC} + 0.5V$	$\pm 20mA$
DC Output Diode Current, I_{OK}	
For $V_O < -0.5V$ or $V_O > V_{CC} + 0.5V$	$\pm 20mA$
DC Output Source or Sink Current per Output Pin, I_O	
For $V_O > -0.5V$ or $V_O < V_{CC} + 0.5V$	$\pm 25mA$
DC V_{CC} or Ground Current, I_{CC}	$\pm 50mA$

Thermal Information

Package Thermal Impedance, θ_{JA} (see Note 5):	
E (PDIP) Package	67°C/W
M (SOIC) Package	73°C/W
NS (SOP) Package	64°C/W
PW (TSSOP) Package	108°C/W
Maximum Junction Temperature	150°C
Maximum Storage Temperature Range	-65°C to 150°C
Maximum Lead Temperature (Soldering 10s)	300°C
(SOIC - Lead Tips Only)	

Operating Conditions

Temperature Range, T_A	-55°C to 125°C
Supply Voltage Range, V_{CC} (Note 3)	
HC Types2V to 6V
HCT Types	4.5V to 5.5V
DC Input or Output Voltage, V_I, V_O	0V to V_{CC}
Input Rise and Fall Times, t_r, t_f	
Reset Input:	
2V	1000ns (Max)
4.5V	500ns (Max)
6V	400ns (Max)
Trigger Inputs A or B:	
2V	Unlimited (Max)
4.5V	Unlimited (Max)
6V	Unlimited (Max)
External Timing Resistor, R_X (Note 4)5k Ω (Min)
External Timing Capacitor, C_X (Note 4)	0 (Min)

CAUTION: Stresses above those listed in "Absolute Maximum Ratings" may cause permanent damage to the device. This is a stress only rating and operation of the device at these or any other conditions above those indicated in the operational sections of this specification is not implied.

NOTES:

3. Unless otherwise specified, all voltages are referenced to ground.
4. The maximum allowable values of R_X and C_X are a function of leakage of capacitor C_X , the leakage of the 'HC4538, and leakage due to board layout and surface resistance. Values of R_X and C_X should be chosen so that the maximum current into pin 2 or pin 14 is 30mA. Susceptibility to externally induced noise signals may occur for $R_X > 1M\Omega$.
5. The package thermal impedance is calculated in accordance with JESD 51-7.

DC Electrical Specifications

PARAMETER	SYMBOL	TEST CONDITIONS		V_{CC} (V)	25°C			-40°C TO 85°C		-55°C TO 125°C		UNITS	
		V_I (V)	I_O (mA)		MIN	TYP	MAX	MIN	MAX	MIN	MAX		
HC TYPES													
High Level Input Voltage	V_{IH}	-	-	2	1.5	-	-	1.5	-	1.5	-	V	
				4.5	3.15	-	-	3.15	-	3.15	-	V	
				6	4.2	-	-	4.2	-	4.2	-	V	
Low Level Input Voltage	V_{IL}	-	-	2	-	-	0.5	-	0.5	-	0.5	V	
				4.5	-	-	1.35	-	1.35	-	1.35	V	
				6	-	-	1.8	-	1.8	-	1.8	V	
High Level Output Voltage CMOS Loads	V_{OH}	V_{IH} or V_{IL}	-0.02	2	1.9	-	-	1.9	-	1.9	-	V	
				4.5	4.4	-	-	4.4	-	4.4	-	V	
				6	5.9	-	-	5.9	-	5.9	-	V	
High Level Output Voltage TTL Loads	V_{OH}	V_{IH} or V_{IL}	-	-	-	-	-	-	-	-	-	V	
				-4	4.5	3.98	-	-	3.84	-	3.7	-	V
				-5.2	6	5.48	-	-	5.34	-	5.2	-	V

CD54HC4538, CD74HC4538, CD54HCT4538, CD74HCT4538

DC Electrical Specifications (Continued)

PARAMETER	SYMBOL	TEST CONDITIONS		V _{CC} (V)	25°C			-40°C TO 85°C		-55°C TO 125°C		UNITS
		V _I (V)	I _O (mA)		MIN	TYP	MAX	MIN	MAX	MIN	MAX	
Low Level Output Voltage CMOS Loads	V _{OL}	V _{IH} or V _{IL}	0.02	2	-	-	0.1	-	0.1	-	0.1	V
			0.02	4.5	-	-	0.1	-	0.1	-	0.1	V
			0.02	6	-	-	0.1	-	0.1	-	0.1	V
Low Level Output Voltage TTL Loads	V _{OL}	V _{IH} or V _{IL}	-	-	-	-	-	-	-	-	-	V
			4	4.5	-	-	0.26	-	0.33	-	0.4	V
			5.2	6	-	-	0.26	-	0.33	-	0.4	V
Input Leakage Current A, B, R	I _I	V _{CC} or GND	-	6	-	-	±0.1	-	±1	-	±1	μA
Input Leakage Current R _X C _X (Note 6)			-	6	-	-	±0.05	-	±0.5	-	±0.5	μA
Quiescent Device Current	I _{CC}	V _{CC} or GND	0	6	-	-	8	-	80	-	160	μA
Active Device Current Q = High & Pins 2, 14 at V _{CC} /4	I _{CC}	V _{CC} or GND	0	6	-	-	0.6	-	0.8	-	1	mA
HCT TYPES												
High Level Input Voltage	V _{IH}	-	-	4.5 to 5.5	2	-	-	2	-	2	-	V
Low Level Input Voltage	V _{IL}	-	-	4.5 to 5.5	-	-	0.8	-	0.8	-	0.8	V
High Level Output Voltage CMOS Loads	V _{OH}	V _{IH} or V _{IL}	-0.02	4.5	4.4	-	-	4.4	-	4.4	-	V
			-4	4.5	3.98	-	-	3.84	-	3.7	-	V
Low Level Output Voltage CMOS Loads	V _{OL}	V _{IH} or V _{IL}	0.02	4.5	-	-	0.1	-	0.1	-	0.1	V
			4	4.5	-	-	0.26	-	0.33	-	0.4	V
Low Level Output Voltage TTL Loads	V _{OL}	V _{IH} or V _{IL}	-	-	-	-	-	-	-	-	-	V
			4	4.5	-	-	0.26	-	0.33	-	0.4	V
Input Leakage Current	I _I	V _{CC} and GND	-	5.5	-	-	±0.1	-	±1	-	±1	μA
Input Leakage Current R _X C _X (Note 6)			-	5.5	-	-	±0.05	-	±0.5	-	±0.5	μA
Quiescent Device Current	I _{CC}	V _{CC} or GND	0	5.5	-	-	8	-	80	-	160	μA
Active Device Current Q = High & Pins 2, 14 at V _{CC} /4	I _{CC}	V _{CC} or GND	0	5.5	-	-	0.6	-	0.8	-	1	mA
Additional Quiescent Device Current Per Input Pin: 1 Unit Load	ΔI _{CC} (Note 7)	V _{CC} -2.1	-	4.5 to 5.5	-	100	360	-	450	-	490	μA

NOTES:

- When testing I_{IL} the Q output must be high. If Q is low (device not triggered) the pull-up P device will be ON and the low resistance path from V_{DD} to the test pin will cause a current far exceeding the specification.
- For dual-supply systems theoretical worst case (V_I = 2.4V, V_{CC} = 5.5V) specification is 1.8mA.

CD54HC4538, CD74HC4538, CD54HCT4538, CD74HCT4538

HCT Input Loading Table

INPUT	UNIT LOADS
All	0.5

NOTE: Unit Load is ΔI_{CC} limit specified in DC Electrical Table, e.g. 360 μ A max at 25°C.

Prerequisite for Switching Specifications

PARAMETER	SYMBOL	V_{CC} (V)	25°C			-40°C TO 85°C			-55°C TO 125°C			UNITS
			MIN	TYP	MAX	MIN	TYP	MAX	MIN	TYP	MAX	
HC TYPES												
Input Pulse Widths A, \bar{B}	t_{WH}, t_{WL}	2	80	-	-	100	-	-	120	-	-	ns
		4.5	16	-	-	20	-	-	24	-	-	ns
		6	14	-	-	17	-	-	20	-	-	ns
\bar{R}	t_{WL}	2	80	-	-	100	-	-	120	-	-	ns
		4.5	16	-	-	20	-	-	24	-	-	ns
		6	14	-	-	17	-	-	20	-	-	ns
Reset Recovery Time	t_{REC}	2	5	-	-	5	-	-	5	-	-	ns
		4.5	5	-	-	5	-	-	5	-	-	ns
		6	5	-	-	5	-	-	5	-	-	ns
Retrigger Time (Figure 11)	t_{rT}	5	-	175	-	-	-	-	-	-	-	ns
HCT TYPES												
Input Pulse Widths A, \bar{B}	t_{WH}, t_{WL}	4.5	16	-	-	20	-	-	24	-	-	ns
		\bar{R}	t_{WL}	4.5	20	-	-	25	-	-	30	-
Reset Recovery Time	t_{REC}	4.5	5	-	-	5	-	-	5	-	-	ns
Retrigger Time (Figure 11)	t_{rT}	5	-	175	-	-	-	-	-	-	-	ns

CD54HC4538, CD74HC4538, CD54HCT4538, CD74HCT4538

Switching Specifications $C_L = 50\text{pF}$, Input $t_r, t_f = 6\text{ns}$, $R_X = 10\text{K}\Omega$, $C_X = 0$

PARAMETER	SYMBOL	TEST CONDITIONS	V_{CC} (V)	25°C			-40°C TO 85°C		-55°C TO 125°C		UNITS
				MIN	TYP	MAX	MIN	MAX	MIN	MAX	
HC TYPES											
Propagation Delay A, \bar{B} to Q	t_{PLH}	$C_L = 50\text{pF}$	2	-	-	250	-	315	-	375	ns
			4.5	-	-	50	-	63	-	75	ns
		$C_L = 15\text{pF}$	5	-	21	-	-	-	-	-	ns
		$C_L = 50\text{pF}$	6	-	-	43	-	54	-	64	ns
A, \bar{B} to \bar{Q}	t_{PHL}	$C_L = 50\text{pF}$	2	-	-	250	-	315	-	375	ns
			4.5	-	-	50	-	63	-	75	ns
		$C_L = 15\text{pF}$	5	-	21	-	-	-	-	-	ns
		$C_L = 50\text{pF}$	6	-	-	43	-	54	-	64	ns
\bar{R} to Q	t_{PHL}	$C_L = 50\text{pF}$	2	-	-	250	-	315	-	375	ns
			4.5	-	-	50	-	63	-	75	ns
		$C_L = 15\text{pF}$	5	-	21	-	-	-	-	-	ns
		$C_L = 50\text{pF}$	6	-	-	43	-	54	-	64	ns
\bar{R} to \bar{Q}	t_{PLH}	$C_L = 50\text{pF}$	2	-	-	250	-	315	-	375	ns
			4.5	-	-	50	-	63	-	75	ns
		$C_L = 15\text{pF}$	5	-	21	-	-	-	-	-	ns
		$C_L = 50\text{pF}$	6	-	-	43	-	54	-	64	ns
Output Transition Time	t_{TLH}, t_{THL}	$C_L = 50\text{pF}$	2	-	-	75	-	95	-	110	ns
			4.5	-	-	15	-	19	-	22	ns
			6	-	-	13	-	16	-	19	ns
Output Pulse Width $R_X = 10\text{k}$, $C_X = 0.1\mu\text{F}$	τ	$C_L = 50\text{pF}$	3	0.64	-	0.78	0.612	0.812	0.605	0.819	ms
			5	0.63	-	0.77	0.602	0.798	0.595	0.805	ms
Output Pulse Width Match, Same Package	-	-	-	-	± 1	-	-	-	-	%	
Power Dissipation Capacitance (Notes 8, 9)	C_{PD}	$C_L = 15\text{pF}$	5	-	136	-	-	-	-	-	pF
Input Capacitance	C_I	$C_L = 50\text{pF}$	-	10	-	10	-	10	-	10	pF
HCT TYPES											
Propagation Delay A, \bar{B} to Q	t_{PLH}	$C_L = 50\text{pF}$	4.5	-	-	55	-	69	-	83	ns
		$C_L = 15\text{pF}$	5	-	23	-	-	-	-	-	ns
A, \bar{B} to \bar{Q}	t_{PHL}	$C_L = 50\text{pF}$	4.5	-	-	55	-	69	-	83	ns
		$C_L = 15\text{pF}$	5	-	23	-	-	-	-	-	ns

CD54HC4538, CD74HC4538, CD54HCT4538, CD74HCT4538

Switching Specifications $C_L = 50\text{pF}$, Input $t_r, t_f = 6\text{ns}$, $R_X = 10\text{K}\Omega$, $C_X = 0$ (Continued)

PARAMETER	SYMBOL	TEST CONDITIONS	V_{CC} (V)	25°C			-40°C TO 85°C		-55°C TO 125°C		UNITS
				MIN	TYP	MAX	MIN	MAX	MIN	MAX	
\bar{R} to Q	t_{PHL}	$C_L = 50\text{pF}$	4.5	-	-	40	-	50	-	60	ns
		$C_L = 15\text{pF}$	5	-	17	-	-	-	-	-	ns
\bar{R} to \bar{Q}	t_{PLH}	$C_L = 50\text{pF}$	4.5	-	-	50	-	63	-	75	ns
		$C_L = 15\text{pF}$	5	-	21	-	-	-	-	-	ns
Output Transition Time	t_{TLH}, t_{THL}	$C_L = 50\text{pF}$	4.5	-	-	15	-	19	-	22	ns
Output Pulse Width $R_X = 10\text{k}$, $C_X = 0.1\mu\text{F}$	τ	$C_L = 50\text{pF}$	5	0.63	-	0.77	0.602	0.798	0.595	0.805	ms
Output Pulse Width Match, Same Package	-	-	-	-	± 1	-	-	-	-	-	%
Power Dissipation Capacitance (Notes 8, 9)	C_{PD}	$C_L = 15\text{pF}$	5	-	134	-	-	-	-	-	pF
Input Capacitance	C_I	$C_L = 50\text{pF}$	-	10	-	10	-	10	-	10	pF

NOTES:

8. C_{PD} is used to determine the dynamic power consumption, per one shot.
9. $P_D = (C_{PD} + C_X) V_{CC}^2 f_i \sum (C_L V_{CC}^2 f_O)$ where f_i = input frequency, f_O = output frequency, C_L = output load capacitance, C_X = external capacitance V_{CC} = supply voltage assuming $f_i \ll \frac{1}{\tau}$

Test Circuits and Waveforms

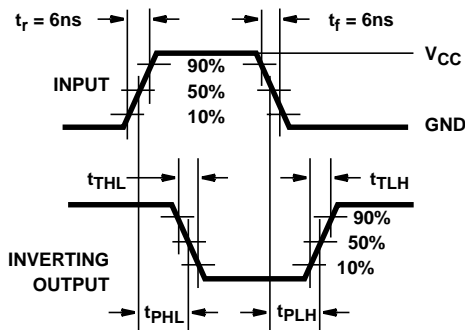

FIGURE 6. HC AND HCU TRANSITION TIMES AND PROPAGATION DELAY TIMES, COMBINATION LOGIC

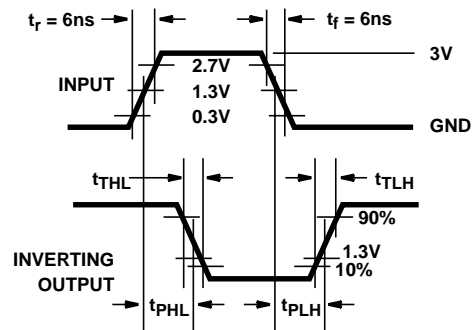

FIGURE 7. HCT TRANSITION TIMES AND PROPAGATION DELAY TIMES, COMBINATION LOGIC

Typical Performance Curves

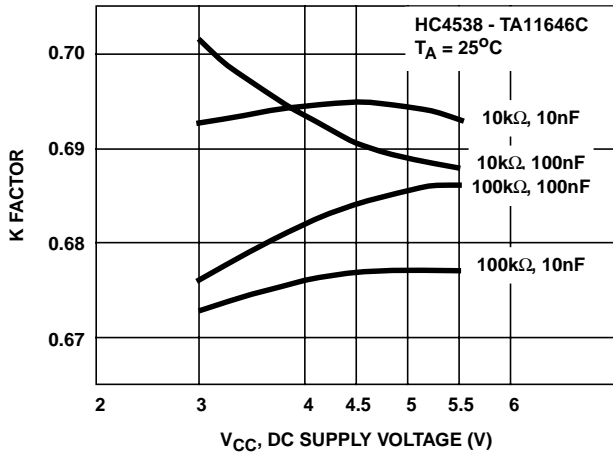

FIGURE 8. K FACTOR vs DC SUPPLY VOLTAGE (V_{CC}) - V

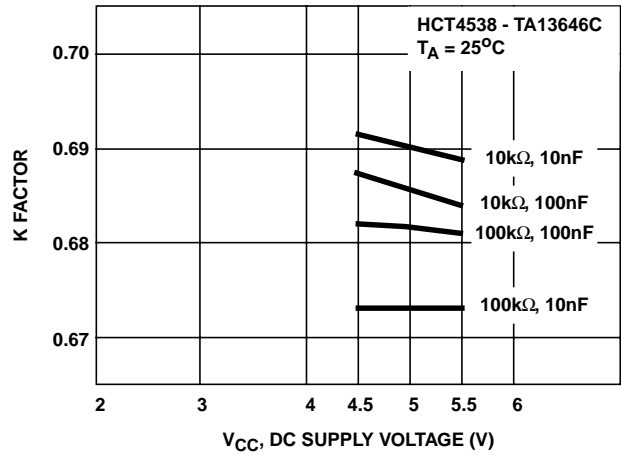

FIGURE 9. K FACTOR vs DC SUPPLY VOLTAGE (V_{CC}) - V

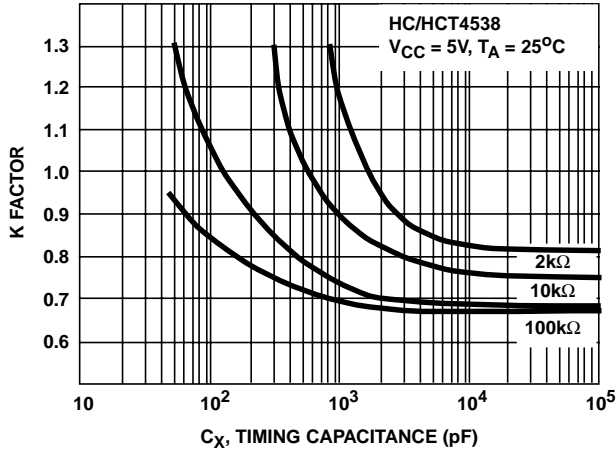

FIGURE 10. K FACTOR vs C_X

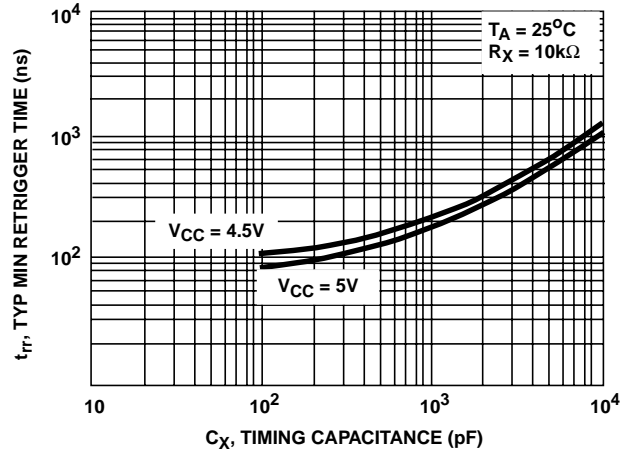

FIGURE 11. MINIMUM RETRIGGER TIME vs TIMING CAPACITANCE

Power-Down Mode

During a rapid power-down condition, as would occur with a power-supply short circuit with a poorly filtered power supply, the energy stored in C_X could discharge into Pin 2 or 14. To avoid possible device damage in this mode, when C_X is $\geq 0.5\mu\text{F}$, a protection diode with a 1 ampere or higher rating (1N5395 or equivalent) and a separate ground return for C_X should be provided as shown in Figure 12.

An alternate protection method is shown in Figure 13, where a 51Ω current-limiting resistor is inserted in series with C_X . Note that a small pulse width decrease will occur however, and R_X must be appropriately increased to obtain the originally desired pulse width.

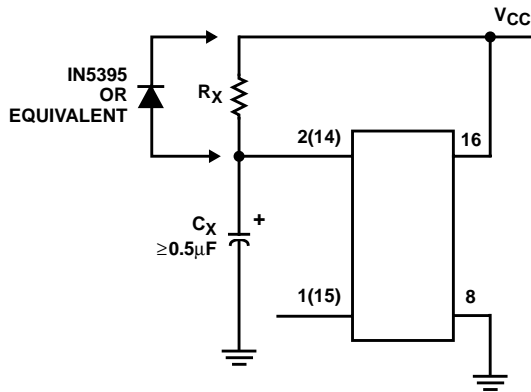

FIGURE 12. RAPID POWER-DOWN PROTECTION CIRCUIT

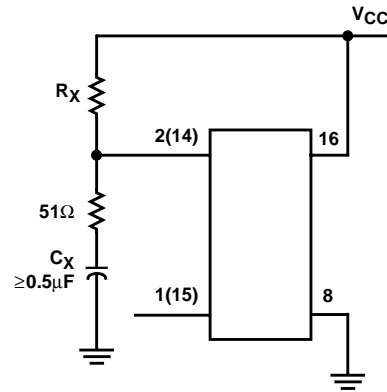

FIGURE 13. ALTERNATE RAPID POWER-DOWN PROTECTION CIRCUIT

PACKAGING INFORMATION

Orderable Device	Status (1)	Package Type	Package Drawing	Pins	Package Qty	Eco Plan (2)	Lead finish/ Ball material (6)	MSL Peak Temp (3)	Op Temp (°C)	Device Marking (4/5)	Samples
5962-8688601EA	ACTIVE	CDIP	J	16	25	Non-RoHS & Green	SNPB	N / A for Pkg Type	-55 to 125	5962-8688601EA CD54HC4538F3A	Samples
CD54HC4538F	ACTIVE	CDIP	J	16	25	Non-RoHS & Green	SNPB	N / A for Pkg Type	-55 to 125	CD54HC4538F	Samples
CD54HC4538F3A	ACTIVE	CDIP	J	16	25	Non-RoHS & Green	SNPB	N / A for Pkg Type	-55 to 125	5962-8688601EA CD54HC4538F3A	Samples
CD54HCT4538F3A	ACTIVE	CDIP	J	16	25	Non-RoHS & Green	SNPB	N / A for Pkg Type	-55 to 125	CD54HCT4538F3A	Samples
CD74HC4538E	ACTIVE	PDIP	N	16	25	RoHS & Green	NIPDAU	N / A for Pkg Type	-55 to 125	CD74HC4538E	Samples
CD74HC4538EE4	ACTIVE	PDIP	N	16	25	RoHS & Green	NIPDAU	N / A for Pkg Type	-55 to 125	CD74HC4538E	Samples
CD74HC4538M96	ACTIVE	SOIC	D	16	2500	RoHS & Green	NIPDAU	Level-1-260C-UNLIM	-55 to 125	HC4538M	Samples
CD74HC4538M96E4	ACTIVE	SOIC	D	16	2500	RoHS & Green	NIPDAU	Level-1-260C-UNLIM	-55 to 125	HC4538M	Samples
CD74HC4538M96G4	ACTIVE	SOIC	D	16	2500	RoHS & Green	NIPDAU	Level-1-260C-UNLIM	-55 to 125	HC4538M	Samples
CD74HC4538NSR	ACTIVE	SO	NS	16	2000	RoHS & Green	NIPDAU	Level-1-260C-UNLIM	-55 to 125	HC4538M	Samples
CD74HC4538PWR	ACTIVE	TSSOP	PW	16	2000	RoHS & Green	NIPDAU	Level-1-260C-UNLIM	-55 to 125	HJ4538	Samples
CD74HC4538PWRG4	ACTIVE	TSSOP	PW	16	2000	RoHS & Green	NIPDAU	Level-1-260C-UNLIM	-55 to 125	HJ4538	Samples
CD74HCT4538E	ACTIVE	PDIP	N	16	25	RoHS & Green	NIPDAU	N / A for Pkg Type	-55 to 125	CD74HCT4538E	Samples
CD74HCT4538M96	ACTIVE	SOIC	D	16	2500	RoHS & Green	NIPDAU	Level-1-260C-UNLIM	-55 to 125	HCT4538M	Samples

(1) The marketing status values are defined as follows:

ACTIVE: Product device recommended for new designs.

LIFEBUY: TI has announced that the device will be discontinued, and a lifetime-buy period is in effect.

NRND: Not recommended for new designs. Device is in production to support existing customers, but TI does not recommend using this part in a new design.

PREVIEW: Device has been announced but is not in production. Samples may or may not be available.

OBSELETE: TI has discontinued the production of the device.

(2) **RoHS:** TI defines "RoHS" to mean semiconductor products that are compliant with the current EU RoHS requirements for all 10 RoHS substances, including the requirement that RoHS substance do not exceed 0.1% by weight in homogeneous materials. Where designed to be soldered at high temperatures, "RoHS" products are suitable for use in specified lead-free processes. TI may reference these types of products as "Pb-Free".

RoHS Exempt: TI defines "RoHS Exempt" to mean products that contain lead but are compliant with EU RoHS pursuant to a specific EU RoHS exemption.

Green: TI defines "Green" to mean the content of Chlorine (Cl) and Bromine (Br) based flame retardants meet JS709B low halogen requirements of ≤ 1000 ppm threshold. Antimony trioxide based flame retardants must also meet the ≤ 1000 ppm threshold requirement.

(3) MSL, Peak Temp. - The Moisture Sensitivity Level rating according to the JEDEC industry standard classifications, and peak solder temperature.

(4) There may be additional marking, which relates to the logo, the lot trace code information, or the environmental category on the device.

(5) Multiple Device Markings will be inside parentheses. Only one Device Marking contained in parentheses and separated by a "~" will appear on a device. If a line is indented then it is a continuation of the previous line and the two combined represent the entire Device Marking for that device.

(6) Lead finish/Ball material - Orderable Devices may have multiple material finish options. Finish options are separated by a vertical ruled line. Lead finish/Ball material values may wrap to two lines if the finish value exceeds the maximum column width.

Important Information and Disclaimer: The information provided on this page represents TI's knowledge and belief as of the date that it is provided. TI bases its knowledge and belief on information provided by third parties, and makes no representation or warranty as to the accuracy of such information. Efforts are underway to better integrate information from third parties. TI has taken and continues to take reasonable steps to provide representative and accurate information but may not have conducted destructive testing or chemical analysis on incoming materials and chemicals. TI and TI suppliers consider certain information to be proprietary, and thus CAS numbers and other limited information may not be available for release.

In no event shall TI's liability arising out of such information exceed the total purchase price of the TI part(s) at issue in this document sold by TI to Customer on an annual basis.

OTHER QUALIFIED VERSIONS OF CD54HC4538, CD54HCT4538, CD74HC4538, CD74HCT4538 :

- Catalog : [CD74HC4538](#), [CD74HCT4538](#)

- Automotive : [CD74HC4538-Q1](#), [CD74HC4538-Q1](#)

- Military : [CD54HC4538](#), [CD54HCT4538](#)

NOTE: Qualified Version Definitions:

- Catalog - TI's standard catalog product

- Automotive - Q100 devices qualified for high-reliability automotive applications targeting zero defects

- Military - QML certified for Military and Defense Applications

TAPE AND REEL INFORMATION

QUADRANT ASSIGNMENTS FOR PIN 1 ORIENTATION IN TAPE

*All dimensions are nominal

Device	Package Type	Package Drawing	Pins	SPQ	Reel Diameter (mm)	Reel Width W1 (mm)	A0 (mm)	B0 (mm)	K0 (mm)	P1 (mm)	W (mm)	Pin1 Quadrant
CD74HC4538M96	SOIC	D	16	2500	330.0	16.4	6.5	10.3	2.1	8.0	16.0	Q1
CD74HC4538NSR	SO	NS	16	2000	330.0	16.4	8.2	10.5	2.5	12.0	16.0	Q1
CD74HC4538PWR	TSSOP	PW	16	2000	330.0	12.4	6.9	5.6	1.6	8.0	12.0	Q1
CD74HCT4538M96	SOIC	D	16	2500	330.0	16.4	6.5	10.3	2.1	8.0	16.0	Q1

TAPE AND REEL BOX DIMENSIONS

*All dimensions are nominal

Device	Package Type	Package Drawing	Pins	SPQ	Length (mm)	Width (mm)	Height (mm)
CD74HC4538M96	SOIC	D	16	2500	340.5	336.1	32.0
CD74HC4538NSR	SO	NS	16	2000	356.0	356.0	35.0
CD74HC4538PWR	TSSOP	PW	16	2000	356.0	356.0	35.0
CD74HCT4538M96	SOIC	D	16	2500	340.5	336.1	32.0

TUBE

*All dimensions are nominal

Device	Package Name	Package Type	Pins	SPQ	L (mm)	W (mm)	T (μm)	B (mm)
CD74HC4538E	N	PDIP	16	25	506	13.97	11230	4.32
CD74HC4538E	N	PDIP	16	25	506	13.97	11230	4.32
CD74HC4538EE4	N	PDIP	16	25	506	13.97	11230	4.32
CD74HC4538EE4	N	PDIP	16	25	506	13.97	11230	4.32
CD74HCT4538E	N	PDIP	16	25	506	13.97	11230	4.32
CD74HCT4538E	N	PDIP	16	25	506	13.97	11230	4.32



PACKAGE OUTLINE

NS0016A

SOP - 2.00 mm max height

SOP

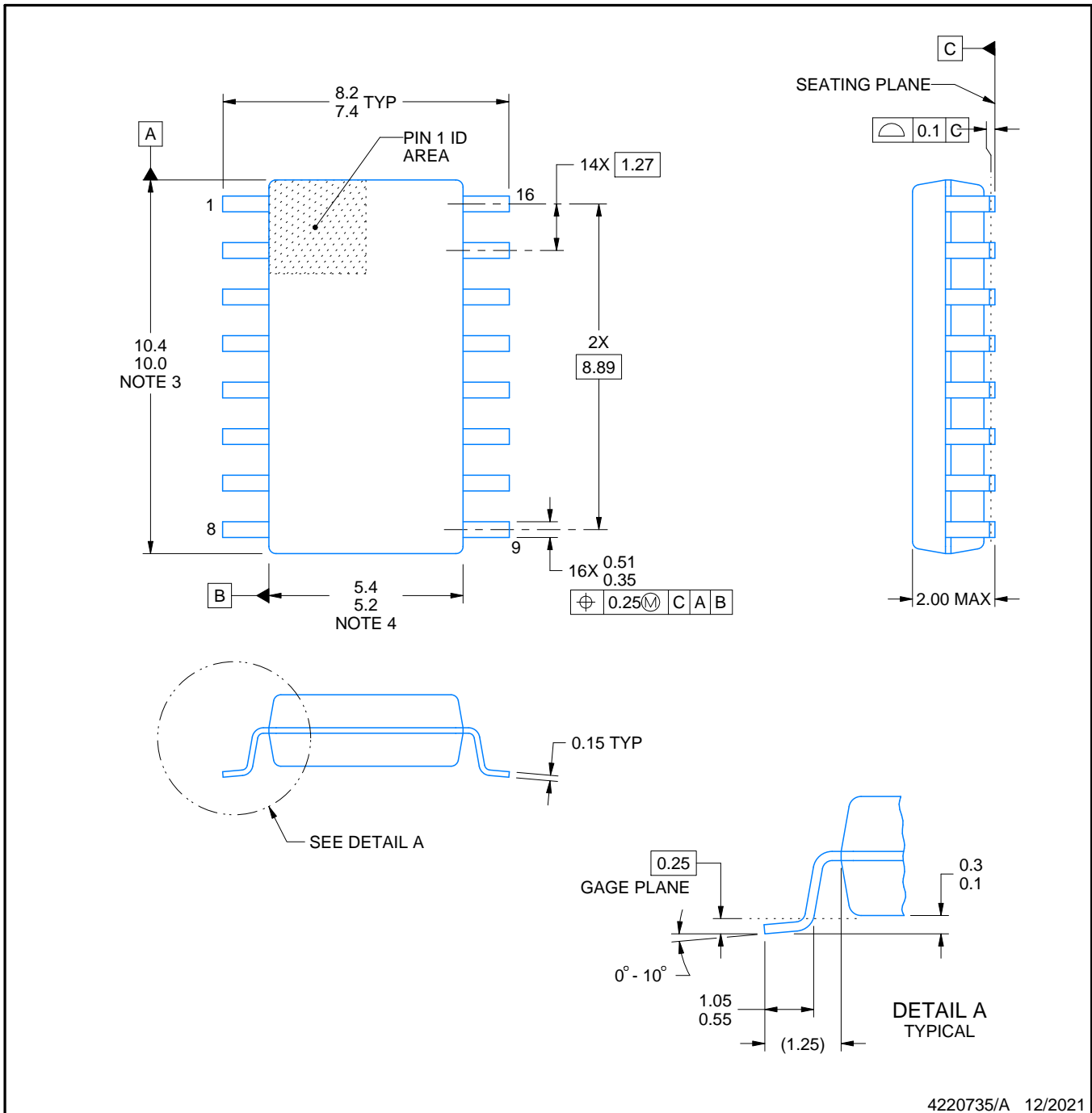

4220735/A 12/2021

NOTES:

1. All linear dimensions are in millimeters. Dimensions in parenthesis are for reference only. Dimensioning and tolerancing per ASME Y14.5M.
2. This drawing is subject to change without notice.
3. This dimension does not include mold flash, protrusions, or gate burrs. Mold flash, protrusions, or gate burrs shall not exceed 0.15 mm, per side.
4. This dimension does not include interlead flash. Interlead flash shall not exceed 0.25 mm, per side.

EXAMPLE BOARD LAYOUT

NS0016A

SOP - 2.00 mm max height

SOP

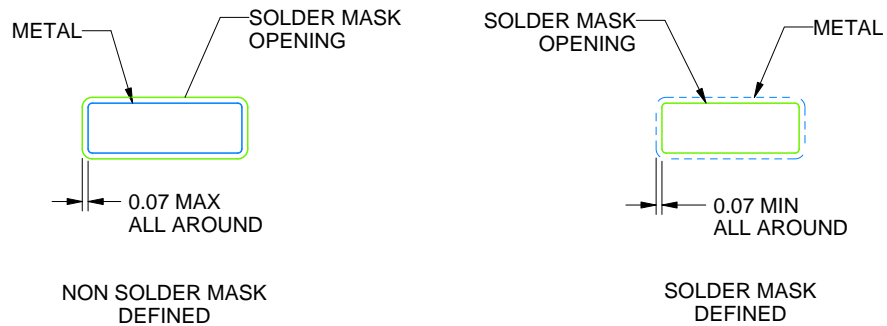

4220735/A 12/2021

NOTES: (continued)

5. Publication IPC-7351 may have alternate designs.

6. Solder mask tolerances between and around signal pads can vary based on board fabrication site.

EXAMPLE STENCIL DESIGN

NS0016A

SOP - 2.00 mm max height

SOP

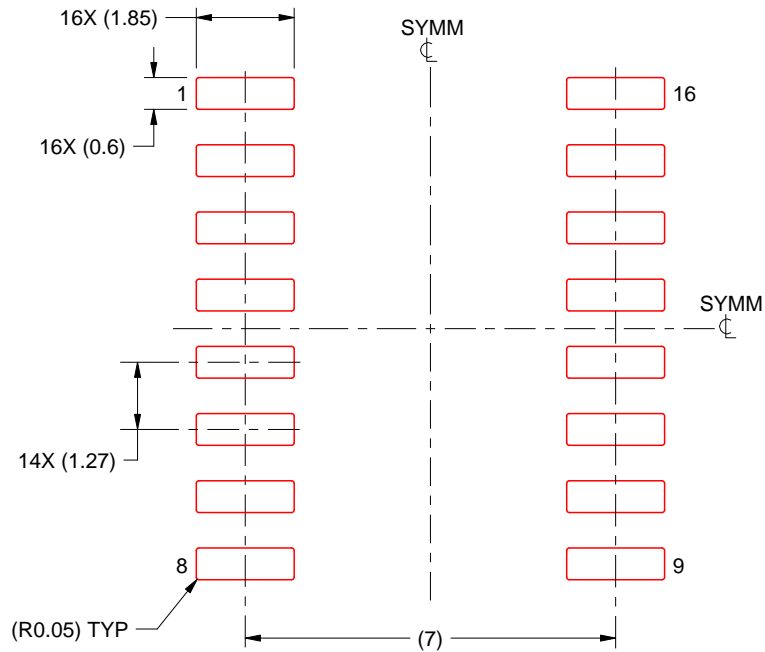

SOLDER PASTE EXAMPLE
BASED ON 0.125 mm THICK STENCIL
SCALE:7X

4220735/A 12/2021



NOTES: (continued)

7. Laser cutting apertures with trapezoidal walls and rounded corners may offer better paste release. IPC-7525 may have alternate design recommendations.
8. Board assembly site may have different recommendations for stencil design.

D (R-PDSO-G16)

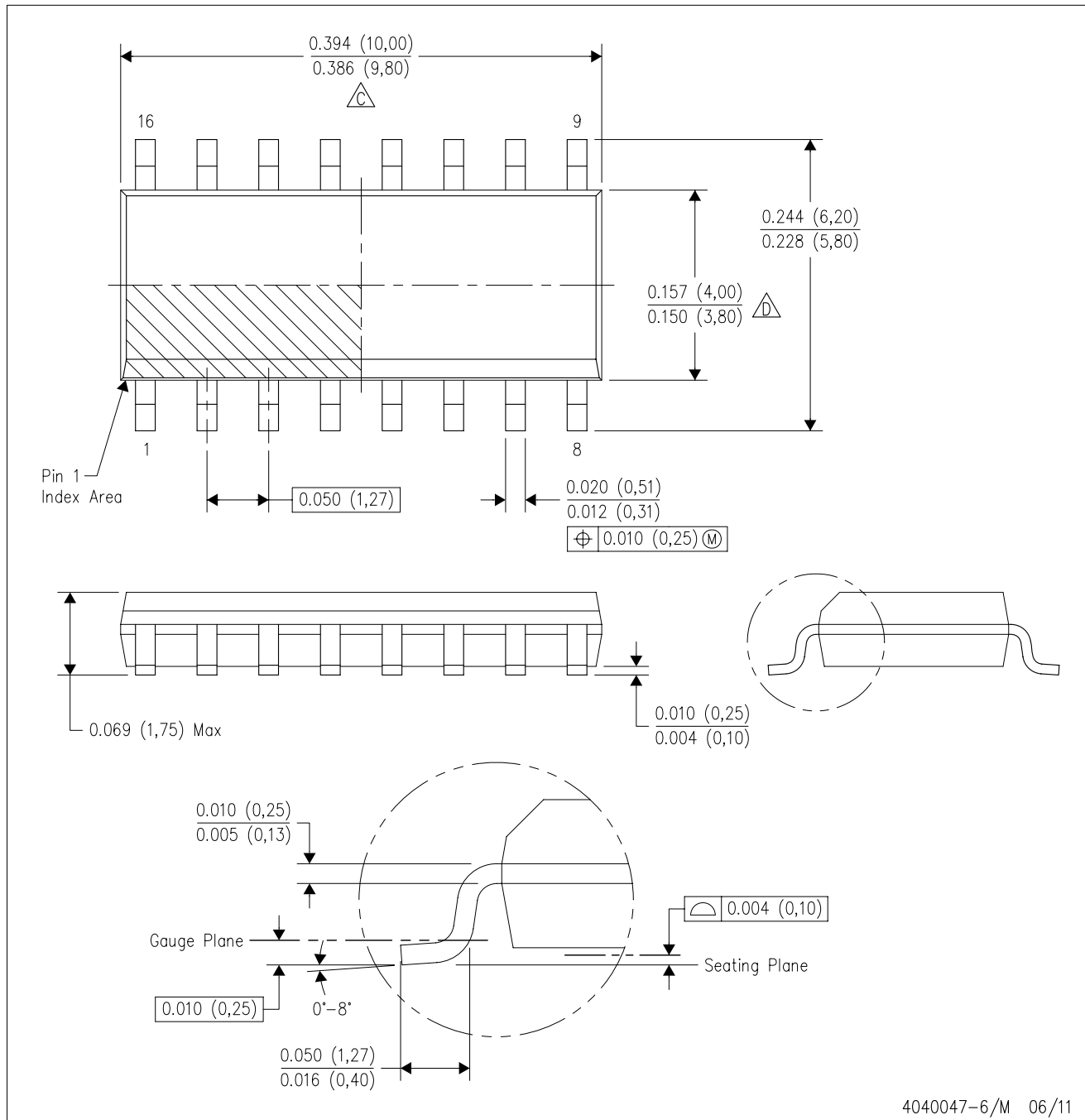
PLASTIC SMALL OUTLINE



- NOTES:
- A. All linear dimensions are in inches (millimeters).
 - B. This drawing is subject to change without notice.
 -  C. Body length does not include mold flash, protrusions, or gate burrs. Mold flash, protrusions, or gate burrs shall not exceed 0.006 (0,15) each side.
 -  D. Body width does not include interlead flash. Interlead flash shall not exceed 0.017 (0,43) each side.
 - E. Reference JEDEC MS-012 variation AC.

D (R-PDSO-G16)

PLASTIC SMALL OUTLINE



4211283-4/E 08/12

- NOTES:
- All linear dimensions are in millimeters.
 - This drawing is subject to change without notice.
 - Publication IPC-7351 is recommended for alternate designs.
 - Laser cutting apertures with trapezoidal walls and also rounding corners will offer better paste release. Customers should contact their board assembly site for stencil design recommendations. Refer to IPC-7525 for other stencil recommendations.
 - Customers should contact their board fabrication site for solder mask tolerances between and around signal pads.

EXAMPLE BOARD LAYOUT

PW0016A

TSSOP - 1.2 mm max height

SMALL OUTLINE PACKAGE



LAND PATTERN EXAMPLE
EXPOSED METAL SHOWN
SCALE: 10X



SOLDER MASK DETAILS

4220204/A 02/2017

NOTES: (continued)

- 6. Publication IPC-7351 may have alternate designs.
- 7. Solder mask tolerances between and around signal pads can vary based on board fabrication site.

EXAMPLE STENCIL DESIGN

PW0016A

TSSOP - 1.2 mm max height

SMALL OUTLINE PACKAGE



SOLDER PASTE EXAMPLE
BASED ON 0.125 mm THICK STENCIL
SCALE: 10X

4220204/A 02/2017

NOTES: (continued)

8. Laser cutting apertures with trapezoidal walls and rounded corners may offer better paste release. IPC-7525 may have alternate design recommendations.
9. Board assembly site may have different recommendations for stencil design.

MECHANICAL DATA

NS (R-PDSO-G**)

PLASTIC SMALL-OUTLINE PACKAGE

14-PINS SHOWN



- NOTES:
- A. All linear dimensions are in millimeters.
 - B. This drawing is subject to change without notice.
 - C. Body dimensions do not include mold flash or protrusion, not to exceed 0,15.

J (R-GDIP-T**)

14 LEADS SHOWN

CERAMIC DUAL IN-LINE PACKAGE



DIM \ PINS **	14	16	18	20
A	0.300 (7,62) BSC	0.300 (7,62) BSC	0.300 (7,62) BSC	0.300 (7,62) BSC
B MAX	0.785 (19,94)	.840 (21,34)	0.960 (24,38)	1.060 (26,92)
B MIN	—	—	—	—
C MAX	0.300 (7,62)	0.300 (7,62)	0.310 (7,87)	0.300 (7,62)
C MIN	0.245 (6,22)	0.245 (6,22)	0.220 (5,59)	0.245 (6,22)



4040083/F 03/03

- NOTES:
- A. All linear dimensions are in inches (millimeters).
 - B. This drawing is subject to change without notice.
 - C. This package is hermetically sealed with a ceramic lid using glass frit.
 - D. Index point is provided on cap for terminal identification only on press ceramic glass frit seal only.
 - E. Falls within MIL STD 1835 GDIP1-T14, GDIP1-T16, GDIP1-T18 and GDIP1-T20.

N (R-PDIP-T**)

PLASTIC DUAL-IN-LINE PACKAGE

16 PINS SHOWN



- NOTES:
- A. All linear dimensions are in inches (millimeters).
 - B. This drawing is subject to change without notice.
 - C Falls within JEDEC MS-001, except 18 and 20 pin minimum body length (Dim A).
 - D The 20 pin end lead shoulder width is a vendor option, either half or full width.

4040049/E 12/2002

IMPORTANT NOTICE AND DISCLAIMER

TI PROVIDES TECHNICAL AND RELIABILITY DATA (INCLUDING DATA SHEETS), DESIGN RESOURCES (INCLUDING REFERENCE DESIGNS), APPLICATION OR OTHER DESIGN ADVICE, WEB TOOLS, SAFETY INFORMATION, AND OTHER RESOURCES "AS IS" AND WITH ALL FAULTS, AND DISCLAIMS ALL WARRANTIES, EXPRESS AND IMPLIED, INCLUDING WITHOUT LIMITATION ANY IMPLIED WARRANTIES OF MERCHANTABILITY, FITNESS FOR A PARTICULAR PURPOSE OR NON-INFRINGEMENT OF THIRD PARTY INTELLECTUAL PROPERTY RIGHTS.

These resources are intended for skilled developers designing with TI products. You are solely responsible for (1) selecting the appropriate TI products for your application, (2) designing, validating and testing your application, and (3) ensuring your application meets applicable standards, and any other safety, security, regulatory or other requirements.

These resources are subject to change without notice. TI grants you permission to use these resources only for development of an application that uses the TI products described in the resource. Other reproduction and display of these resources is prohibited. No license is granted to any other TI intellectual property right or to any third party intellectual property right. TI disclaims responsibility for, and you will fully indemnify TI and its representatives against, any claims, damages, costs, losses, and liabilities arising out of your use of these resources.

TI's products are provided subject to [TI's Terms of Sale](#) or other applicable terms available either on [ti.com](https://www.ti.com) or provided in conjunction with such TI products. TI's provision of these resources does not expand or otherwise alter TI's applicable warranties or warranty disclaimers for TI products.

TI objects to and rejects any additional or different terms you may have proposed.

Mailing Address: Texas Instruments, Post Office Box 655303, Dallas, Texas 75265
Copyright © 2024, Texas Instruments Incorporated

Looking for pricing, stock, or lifecycle information?

Click below to explore more details on WIN SOURCE:

 [View CD54HC4538F3A](#) on WIN SOURCE

 [Texas Instruments](#) Information

Optimize Your Supply Chain with WIN SOURCE Solutions

-  Global Sourcing Solution
-  Obsolete Management
-  Cost Control Management
-  Shortage Management
-  Alternative Solution
-  Excess Inventory Management