



**THE DATASHEET OF
CD54HC4066F3A**



High-Speed CMOS Logic Quad Bilateral Switch

1 Features

- Wide analog-input-voltage range: 0 V – 10 V
- Low ON resistance:
 - $V_{CC} = 4.5\text{ V}$: 25 Ω
 - $V_{CC} = 9\text{ V}$: 15 Ω
- Fast switching and propagation delay times
- Low OFF leakage current
- Wide operating temperature range: -55°C to 125°C
- HC types:
 - 2 V to 10 V operation
 - High noise immunity: $N_{IL} = 30\%$, $N_{IH} = 30\%$ of V_{CC} at $V_{CC} = 5\text{ V}$ and 10 V
- HCT types:
 - Direct LSTTL input logic compatibility, $V_{IL} = 0.8\text{ V}$ (maximum), $V_{IH} = 2\text{ V}$ (minimum)
 - CMOS input compatibility, $I_I \leq 1\ \mu\text{A}$ at V_{OL} , V_{OH}

2 Applications

- Analog signal switching and multiplexing: signal gating, modulators, squelch controls, demodulators, choppers, commutating switches
- Digital signal switching and multiplexing: Analog-to-digital and digital-to-analog conversions
- Digital control of frequency, impedance, phase, and analog-signal gain
- Building automation

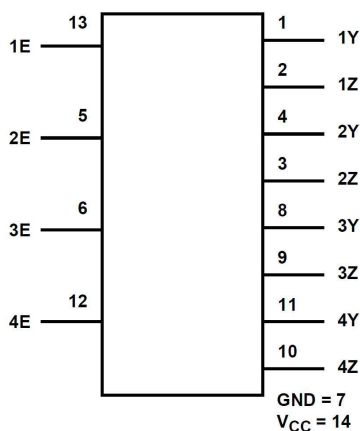

Functional Block Diagram

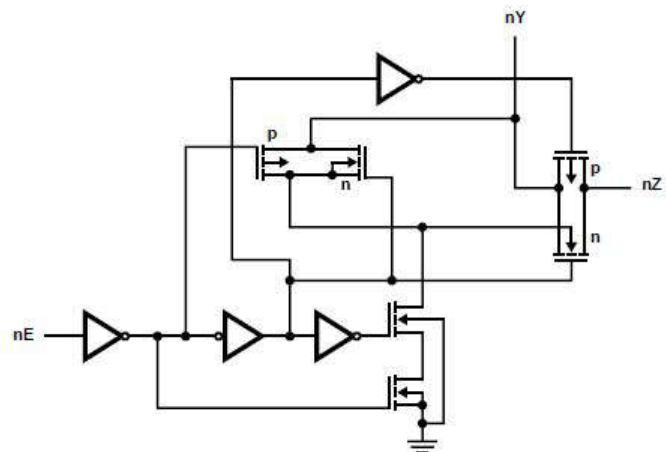

Logic Diagram

3 Description

The 'HC4066 and CD74HCT4066 devices contain four independent digitally controlled analog switches that use silicon-gate CMOS technology to achieve operating speeds similar to LSTTL with the low power consumption of standard CMOS integrated circuits.

These switches feature the characteristic linear ON resistance of the metal-gate CD4066B device. Each switch is turned on by a high-level voltage on its control input.

Device Information

PART NUMBER	TEMP. RANGE ($^{\circ}\text{C}$)	PACKAGE ⁽¹⁾
CD74HC4066	-55 to 125	D (SOIC, 14)
	-55 to 125	PW (TSSOP, 14)
CD74HCT4066	-55 to 125	D (SOIC, 14)

(1) For more information, see [Section 19](#).

Table of Contents

1 Features	1	15 Test Circuits and Waveforms	10
2 Applications	1	16 Detailed Description	11
3 Description	1	16.1 Functional Block Diagram.....	11
4 Pin Configuration and Functions	3	16.2 Device Functional Modes.....	11
5 Absolute Maximum Ratings	4	17 Device and Documentation Support	12
6 ESD Ratings	4	17.1 Receiving Notification of Documentation Updates..	12
7 Thermal Information	4	17.2 Support Resources.....	12
8 Recommended Operating Conditions	5	17.3 Trademarks.....	12
9 Electrical Characteristics: HC Devices	6	17.4 Electrostatic Discharge Caution.....	12
10 Electrical Characteristics: HCT Devices	7	17.5 Glossary.....	12
11 Switching Characteristics HC	8	18 Revision History	12
12 Switching Characteristics HCT	9	19 Mechanical, Packaging, and Orderable Information	12
13 Analog Channel Specifications	9		
14 Analog Test Circuits	10		

4 Pin Configuration and Functions

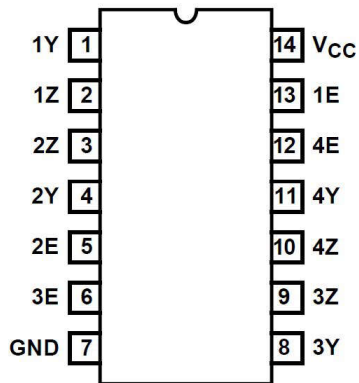

Figure 4-1. CD74HC4066 D or PW Package, 14-Pin SOIC or TSSOP CD74HCT4066 r D Package, 14-Pin SOIC (Top View)

Table 4-1. Pin Functions

PIN		TYPE ⁽¹⁾	DESCRIPTION
NAME	NO.		
1Y	1	I/O	Input/Output for Switch 1
1Z	2	I/O	Input/Output for Switch 1
2Z	3	I/O	Input/Output for Switch 2
2Y	4	I/O	Input/Output for Switch 2
2E	5	I	Control pin for Switch 2
3E	6	I	Control pin for Switch 3
GND	7	-	Ground Pin
3Y	8	I/O	Input/Output for Switch 3
3Z	9	I/O	Input/Output for Switch 3
4Z	10	I/O	Input/Output for Switch 4
4Y	11	I/O	Input/Output for Switch 4
4E	12	I	Control pin for Switch 4
1E	13	I	Control pin for Switch 1
V _{CC}	14	-	Power Pin

(1) Signal Types: I = Input, O = Output, I/O = Input or Output.

5 Absolute Maximum Ratings

over operating free-air temperature range (unless otherwise noted)⁽¹⁾ ⁽²⁾

			MIN	MAX	UNIT
V _{CC} HCT	DC Supply voltage		-0.5	7	V
V _{CC} HC ⁽¹⁾			-0.5	10.5	V
I _{IK}	DC input diode current	For V _I < -0.5V or V _I > V _{CC} + 0.5V	-20	20	mA
I _O	DC switch current ⁽²⁾	For V _I < -0.5V or V _I > V _{CC} + 0.5V	-20	20	mA
I _{OK}	DC Output diode current	For V _O < -0.5V or V _O > V _{CC} + -0.5V	-25	25	mA
DC Output Source or Sink Current per Output Pin, I _O	For V _O > -0.5V or V _O < V _{CC} + -0.5V		-25	25	mA
I _{CC}	DC V _{CC} or ground current		-50	50	mA
T _{JMAX}	Maximum junction temperature (Plastic Package)			150	°C

- Stresses beyond those listed under *Absolute Maximum Rating* may cause permanent damage to the device. These are stress ratings only, which do not imply functional operation of the device at these or any other conditions beyond those indicated under *Recommended Operating Condition*. Exposure to absolute-maximum-rated conditions for extended periods may affect device reliability.
- In certain applications, the external load-resistor current may include both VCC and signal-line components. To avoid drawing VCC current when switch current flows into the transmission gate inputs, (terminals 1, 4, 8 and 11) the voltage drop across the bidirectional switch must not exceed 0.6V (calculated from RON values shown in the DC Electrical Specifications Table). No VCC current will flow through RLif the switch current flows into terminals 2, 3, 9 and 10. 2.

6 ESD Ratings

			VALUE	UNIT
V _(ESD)	Electrostatic discharge	Human body model (HBM), per ANSI/ESDA/ JEDEC JS-001, all pins ⁽¹⁾	±500	V
		Charged device model (CDM), per JEDEC specification JESD22-C101, all pins ⁽²⁾	±200	

- JEDEC document JEP155 states that 500-V HBM allows safe manufacturing with a standard ESD control process.
- JEDEC document JEP157 states that 250-V CDM allows safe manufacturing with a standard ESD control process.

7 Thermal Information

THERMAL METRIC		CD74HCx4066		UNIT
		D (SOIC)	PW (TSSOP)	
		14 PINS	14 PINS	
R _{θJA}	Junction-to-ambient thermal resistance	108.4	133.9	°C/W

8 Recommended Operating Conditions

over operating free-air temperature range (unless otherwise noted)

			MIN	NOM	MAX	UNIT
V _{CC}	Supply voltage range (T _A = full package temperature range)(2)	CD54 and 74HC types	2		10	V
		CD54 and 74HCT types	4.5		5.5	
V _{IS}	Analog switch I/O voltage		0		V _{CC}	V
T _A	Ambient temperature		-55		125	°C
t _r , t _f	Input rise and fall times	2 V	0		1000	ns
		4.5 V	0		500	
		6 V	0		400	

9 Electrical Characteristics: HC Devices

Over operating free-air temperature range, $V_{SUPPLY} = \pm 5\text{ V}$, and $R_L = 100\ \Omega$, (unless otherwise noted)⁽¹⁾

PARAMETER		TEST CONDITIONS				MIN	TYP	MAX	UNIT	
SIGNAL INPUTS (V_{IS}) AND OUTPUTS (V_{OS})										
		V_{IS} (V)	V_I (V)	V_{CC} (V)	T_A					
High Level Input Voltage	V_{IH}			2	25°C			1.5	V	
					-40°C to +85°C			1.5		
					-55°C to +125°C			1.5		
				4.5	25°C			3.15		
					-40°C to +85°C			3.15		
					-55°C to +125°C			3.15		
				9	25°C			6.3		
					-40°C to +85°C			6.3		
					-55°C to +125°C			6.3		
Low Level Input Voltage	V_{IL}			2	25°C		0.5	V		
					-40°C to +85°C		0.5			
					-55°C to +125°C		0.5			
				4.5	25°C		1.35			
					-40°C to +85°C		1.35			
					-55°C to +125°C		1.35			
				9	25°C		2.7			
					-40°C to +85°C		2.7			
					-55°C to +125°C		2.7			
"ON" Resistance $I_O = 1\text{mA}$	R_{ON}	V_{CC} or GND	VCC	4.5	25°C		25	80	Ω	
					-40°C to +85°C			106		
					-55°C to +125°C			128		
				6	25°C		20	75		
					-40°C to +85°C			94		
					-55°C to +125°C			113		
				9	25°C		15	60		
					-40°C to +85°C			78		
					-55°C to +125°C			95		
				V_{CC} to GND	4.5	25°C		35		95
						-40°C to +85°C				118
						-55°C to +125°C				142
					6	25°C		24		84
						-40°C to +85°C				105
						-55°C to +125°C				126
					9	25°C		31		70
						-40°C to +85°C				88
						-55°C to +125°C				105
"ON" Resistance Between Any Two Switches	$\blacktriangle R_{ON}$		VCC	4.5	25°C		1	Ω		
			VCC	6	25°C		0.75			
			VCC	9	25°C		0.5			
Off-Switch Leakage Current	I_Z	V_{CC} or GND	V_{IL}	10	25°C		± 0.1	μA		
					-55°C to 85°C		± 1			
					-55°C to 125°C		± 1			

Over operating free-air temperature range, $V_{SUPPLY} = \pm 5\text{ V}$, and $R_L = 100\ \Omega$, (unless otherwise noted)⁽¹⁾

PARAMETER		TEST CONDITIONS				MIN	TYP	MAX	UNIT
Input Leakage Current (Any Control)	I_{IL}		V_{CC} or GND	10	25°C			±0.1	μA
					-55°C to 85°C			±1	
					-55°C to 125°C			±1	
Quiescent Device Current	I_{CC}		V_{CC} or GND	6	25°C			18.5	μA
					-55°C to 85°C			20	
				-55°C to 125°C			40		
				10	25°C			35	
					-55°C to 85°C			160	
					-55°C to 125°C			320	
CONTROL (ADDRESS OR INHIBIT), V_C									

(1) Peak-to-Peak voltage symmetrical about $(V_{DD} - V_{EE}) / 2$.

10 Electrical Characteristics: HCT Devices

Over operating free-air temperature range, $V_{SUPPLY} = \pm 5\text{ V}$, and $R_L = 100\ \Omega$, (unless otherwise noted)⁽¹⁾

PARAMETER		TEST CONDITIONS				MIN	TYP	MAX	UNIT
SIGNAL INPUTS (V_{IS}) AND OUTPUTS (V_{OS})									
		V_{IS} (V)	V_I (V)	V_{CC} (V)	T_A				
High Level Input Voltage	V_{IH}			4.5 to 5.5	25°C	2			V
					-40°C to +85°C	2			
					-55°C to +125°C	2			
Low Level Input Voltage	V_{IL}				25°C			0.8	V
					-40°C to +85°C			0.8	
					-55°C to +125°C			0.8	
"ON" Resistance $I_O = 1\text{ mA}$	R_{ON}	V_{CC} or GND	V_{CC}	4.5	25°C		25	80	Ω
					-40°C to +85°C			106	
					-55°C to +125°C			128	
		V_{CC} to GND			25°C		35	95	Ω
					-40°C to +85°C			118	
					-55°C to +125°C			142	
"ON" Resistance Between Any Two Switches	$\blacktriangle R_{ON}$		V_{CC}	4.5	25°C		1	Ω	
Off-Switch Leakage Current	I_Z	V_{CC} or GND	V_{IL}	5.5	25°C			±0.1	μA
					-55°C to 85°C			±1	
					-55°C to 125°C			±1	
Input Leakage Current (Any Control)	I_{IL}		V_{CC} or GND	5.5	25°C			±0.1	μA
					-55°C to 85°C			±1	
					-55°C to 125°C			±1	
Quiescent Device Current	I_{CC}		V_{CC} or GND	5.5	25°C			2	μA
					-55°C to 85°C			20	
					-55°C to 125°C			40	
Additional Quiescent Device Current Per Input Pin: 1 Unit Load	$\blacktriangle I_{CC}$		$V_{CC} - 2.1$	4.5 to 5.5	25°C		100	360	μA
					-55°C to 85°C			450	
					-55°C to 125°C			490	

Over operating free-air temperature range, $V_{SUPPLY} = \pm 5\text{ V}$, and $R_L = 100\ \Omega$, (unless otherwise noted)⁽¹⁾

PARAMETER	TEST CONDITIONS	MIN	TYP	MAX	UNIT
CONTROL (ADDRESS OR INHIBIT), V_C					

(1) Peak-to-Peak voltage symmetrical about $(V_{DD} - V_{EE}) / 2$.

11 Switching Characteristics HC

over operating free-air temperature range (unless otherwise noted)

Parameter		Test Conditions		C_L (pF)	MIN	NOM	MAX	UNIT			
Propagation Delay Time Switch In to Out	t_{PHL}, t_{PLH}	2	25°C	50			60	ns			
			-40°C to 85°C				75	ns			
			-55°C to 125°C				90	ns			
		4.5	25°C				12	ns			
			-40°C to 85°C				15	ns			
			-55°C to 125°C				18	ns			
		9	25°C				8	ns			
			-40°C to 85°C				11	ns			
			-55°C to 125°C				13	ns			
					5	25°C	15		4		ns
		Propagation Delay Time Switch Turn On Delay	t_{PZH}, t_{PZL}		2	25°C	50			100	ns
						-40°C to 85°C				125	ns
-55°C to 125°C						150		ns			
4.5	25°C					20		ns			
	-40°C to 85°C					25		ns			
	-55°C to 125°C					30		ns			
9	25°C					12		ns			
	-40°C to 85°C					15		ns			
	-55°C to 125°C					18		ns			
				5	25°C	15			4		ns
Propagation Delay Time Switch Turn Off Delay	t_{PHZ}, t_{PLZ}			2	25°C	50				150	ns
					-40°C to 85°C					190	ns
		-55°C to 125°C					225	ns			
		4.5	25°C				30	ns			
			-40°C to 85°C				38	ns			
			-55°C to 125°C				45	ns			
		9	25°C				24	ns			
			-40°C to 85°C				30	ns			
			-55°C to 125°C				36	ns			
				5	25°C		15		9.5		ns
		Input (Control) Capacitance	C_I		25°C					10	pF
					-40°C to 85°C					10	
	-55°C to 125°C						10				
C_{PD} Power dissipation capacitance(1)	C_{PD}	5	25°C			25					

12 Switching Characteristics HCT

over operating free-air temperature range (unless otherwise noted)

Parameter		Test Conditions		C _L (pF)	MIN	NOM	MAX	UNIT
Propagation Delay Time Switch In to Out	t _{PHL} , t _{PLH}	4.5	25°C	50			12	ns
			-40°C to 85°C				15	ns
			-55°C to 125°C				18	ns
		5	25°C	15		1.3		ns
Propagation Delay Time Switch Turn On Delay	t _{PZH} , t _{PZL}	4.5	25°C	50			24	ns
			-40°C to 85°C				30	ns
			-55°C to 125°C				36	ns
		5	25°C	15		5		ns
Propagation Delay Time Switch Turn Off Delay	t _{PHZ} , t _{PLZ}	4.5	25°C	50			35	ns
			-40°C to 85°C				44	ns
			-55°C to 125°C				53	ns
		5	25°C	15		5.5		ns
Input (Control) Capacitance	C _I		25°C				10	pF
			-40°C to 85°C				10	
			-55°C to 125°C				10	
C _{PD} Power dissipation capacitance(1)	C _{PD}	5	25°C			38		

13 Analog Channel Specifications

over operating free-air temperature range (unless otherwise noted)

Parameter		Test Conditions		V _{CC} (V)	HC	HCT	UNIT
Switch Frequency Response Bandwidth at -3dB				4.5	200	200	MHz
Cross Talk Between Any Two Switches				4.5	-72	-72	dB
Total Harmonic Distortion		1kHz, V _{IS} =4V _{PP}		4.5	0.022	0.023	%
		1kHz, V _{IS} =8V _{PP}		9	0.019	N/A	%
Control to Switch Feedthrough Noise	Control to Switch Feedthrough Noise			4.5	200	130	mV
Control to Switch Feedthrough Noise				4.5	200	130	mV
				9	550	N/A	
Switch "OFF" signal feedthrough				4.5	-72	-72	dB
C _I Switch input capacitance					5	5	pF

14 Analog Test Circuits

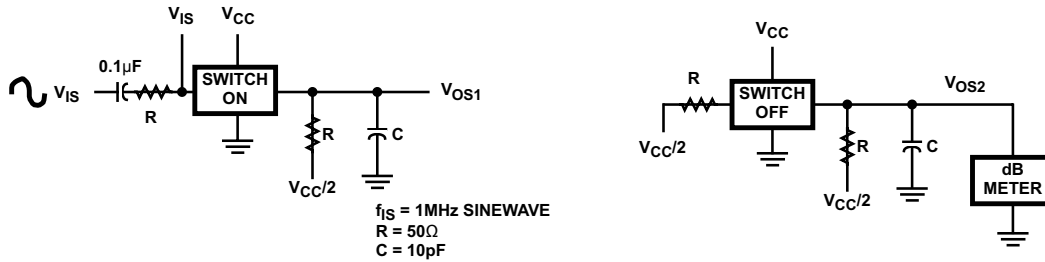

Figure 14-1. Crosstalk Between Two Switches Test Circuit

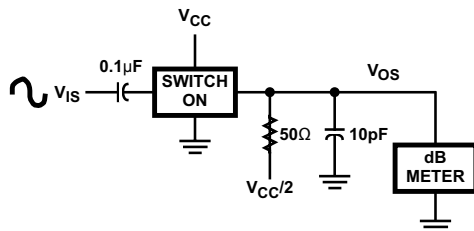

Figure 14-2. Frequency Response Test Circuit

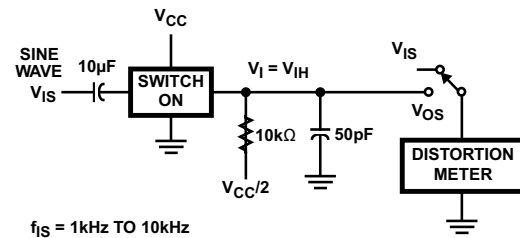

Figure 14-3. Total Harmonic Distortion Test Circuit

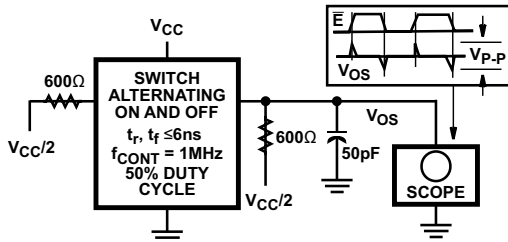

Figure 14-4. Control-To-Switch Feedthrough Noise Test Circuit

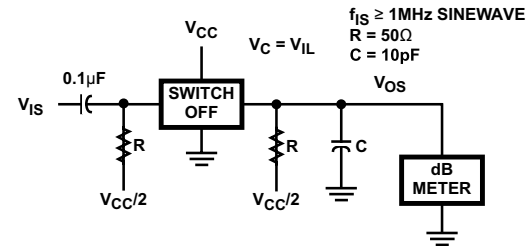

Figure 14-5. Switch OFF Signal Feedthrough

15 Test Circuits and Waveforms

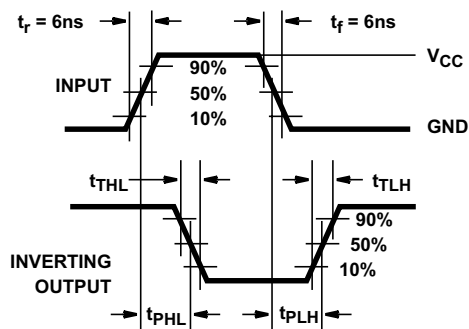

Figure 15-1. HC Transition Times and Propagation Delay Times, Combination Logic

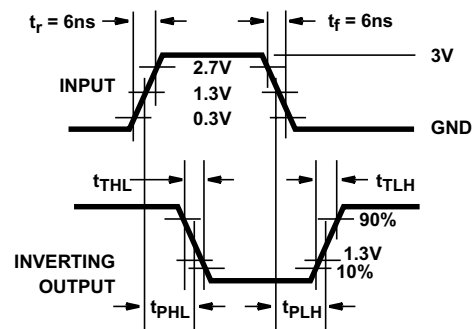

Figure 15-2. HCT Transition Times and Propagation Delay Times, Combination Logic

16 Detailed Description

16.1 Functional Block Diagram

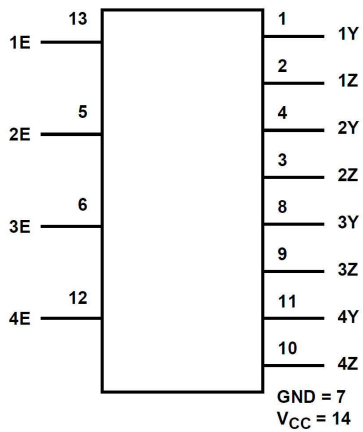

Figure 16-1. Functional Block Diagram

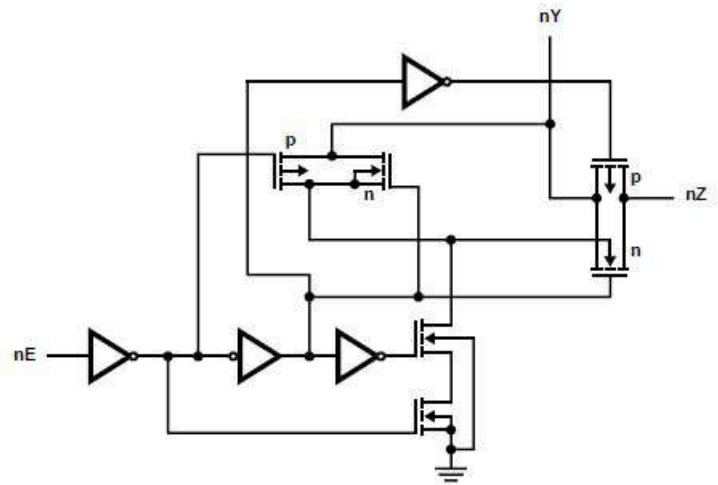

Figure 16-2. Logic Diagram

16.2 Device Functional Modes

Table 16-1. Truth Table

INPUTnE	SWITCH
L ⁽²⁾	Off
H ⁽¹⁾	On

- (1) H = High Level
 (2) L = Low Level

17 Device and Documentation Support

TI offers an extensive line of development tools. Tools and software to evaluate the performance of the device, generate code, and develop solutions are listed below.

17.1 Receiving Notification of Documentation Updates

To receive notification of documentation updates, navigate to the device product folder on ti.com. Click on *Notifications* to register and receive a weekly digest of any product information that has changed. For change details, review the revision history included in any revised document.

17.2 Support Resources

TI E2E™ [support forums](#) are an engineer's go-to source for fast, verified answers and design help — straight from the experts. Search existing answers or ask your own question to get the quick design help you need.

Linked content is provided "AS IS" by the respective contributors. They do not constitute TI specifications and do not necessarily reflect TI's views; see TI's [Terms of Use](#).

17.3 Trademarks

TI E2E™ is a trademark of Texas Instruments.
All trademarks are the property of their respective owners.

17.4 Electrostatic Discharge Caution



This integrated circuit can be damaged by ESD. Texas Instruments recommends that all integrated circuits be handled with appropriate precautions. Failure to observe proper handling and installation procedures can cause damage.

ESD damage can range from subtle performance degradation to complete device failure. Precision integrated circuits may be more susceptible to damage because very small parametric changes could cause the device not to meet its published specifications.

17.5 Glossary

[TI Glossary](#) This glossary lists and explains terms, acronyms, and definitions.

18 Revision History

NOTE: Page numbers for previous revisions may differ from page numbers in the current version.

Changes from Revision D (August 2003) to Revision E (July 2024)	Page
• Updated the numbering format for tables, figures, and cross-references throughout the document.....	1
• Updated thermal information.....	4
• Updated electrical specifications.....	6
• Updated switching specifications.....	8
• Updated analog channel specifications.....	9
• Updated ordering information.....	12

19 Mechanical, Packaging, and Orderable Information

The following pages include mechanical, packaging, and orderable information. This information is the most current data available for the designated devices. This data is subject to change without notice and revision of this document. For browser-based versions of this data sheet, refer to the left-hand navigation.

PACKAGING INFORMATION

Orderable Device	Status (1)	Package Type	Package Drawing	Pins	Package Qty	Eco Plan (2)	Lead finish/ Ball material (6)	MSL Peak Temp (3)	Op Temp (°C)	Device Marking (4/5)	Samples
5962-8950701CA	ACTIVE	CDIP	J	14	25	Non-RoHS & Green	SNPB	N / A for Pkg Type	-55 to 125	5962-8950701CA CD54HC4066F3A	Samples
CD54HC4066F3A	ACTIVE	CDIP	J	14	25	Non-RoHS & Green	SNPB	N / A for Pkg Type	-55 to 125	5962-8950701CA CD54HC4066F3A	Samples
CD74HC4066E	NRND	PDIP	N	14	25	RoHS & Green	NIPDAU	N / A for Pkg Type	-55 to 125	CD74HC4066E	
CD74HC4066EE4	NRND	PDIP	N	14	25	RoHS & Green	NIPDAU	N / A for Pkg Type	-55 to 125	CD74HC4066E	
CD74HC4066M96	ACTIVE	SOIC	D	14	2500	RoHS & Green	NIPDAU	Level-1-260C-UNLIM	-55 to 125	HC4066M	Samples
CD74HC4066M96E4	ACTIVE	SOIC	D	14	2500	RoHS & Green	NIPDAU	Level-1-260C-UNLIM	-55 to 125	HC4066M	Samples
CD74HC4066PWR	ACTIVE	TSSOP	PW	14	2000	RoHS & Green	NIPDAU	Level-1-260C-UNLIM	-55 to 125	HP4066	Samples
CD74HCT4066E	NRND	PDIP	N	14	25	RoHS & Green	NIPDAU	N / A for Pkg Type	-55 to 125	CD74HCT4066E	
CD74HCT4066M96	ACTIVE	SOIC	D	14	2500	RoHS & Green	NIPDAU	Level-1-260C-UNLIM	-55 to 125	HCT4066M	Samples

(1) The marketing status values are defined as follows:

ACTIVE: Product device recommended for new designs.

LIFEBUY: TI has announced that the device will be discontinued, and a lifetime-buy period is in effect.

NRND: Not recommended for new designs. Device is in production to support existing customers, but TI does not recommend using this part in a new design.

PREVIEW: Device has been announced but is not in production. Samples may or may not be available.

OBSOLETE: TI has discontinued the production of the device.

(2) **RoHS:** TI defines "RoHS" to mean semiconductor products that are compliant with the current EU RoHS requirements for all 10 RoHS substances, including the requirement that RoHS substance do not exceed 0.1% by weight in homogeneous materials. Where designed to be soldered at high temperatures, "RoHS" products are suitable for use in specified lead-free processes. TI may reference these types of products as "Pb-Free".

RoHS Exempt: TI defines "RoHS Exempt" to mean products that contain lead but are compliant with EU RoHS pursuant to a specific EU RoHS exemption.

Green: TI defines "Green" to mean the content of Chlorine (Cl) and Bromine (Br) based flame retardants meet JS709B low halogen requirements of <=1000ppm threshold. Antimony trioxide based flame retardants must also meet the <=1000ppm threshold requirement.

(3) MSL, Peak Temp. - The Moisture Sensitivity Level rating according to the JEDEC industry standard classifications, and peak solder temperature.

(4) There may be additional marking, which relates to the logo, the lot trace code information, or the environmental category on the device.

(5) Multiple Device Markings will be inside parentheses. Only one Device Marking contained in parentheses and separated by a "~" will appear on a device. If a line is indented then it is a continuation of the previous line and the two combined represent the entire Device Marking for that device.

(6) Lead finish/Ball material - Orderable Devices may have multiple material finish options. Finish options are separated by a vertical ruled line. Lead finish/Ball material values may wrap to two lines if the finish value exceeds the maximum column width.

Important Information and Disclaimer:The information provided on this page represents TI's knowledge and belief as of the date that it is provided. TI bases its knowledge and belief on information provided by third parties, and makes no representation or warranty as to the accuracy of such information. Efforts are underway to better integrate information from third parties. TI has taken and continues to take reasonable steps to provide representative and accurate information but may not have conducted destructive testing or chemical analysis on incoming materials and chemicals. TI and TI suppliers consider certain information to be proprietary, and thus CAS numbers and other limited information may not be available for release.

In no event shall TI's liability arising out of such information exceed the total purchase price of the TI part(s) at issue in this document sold by TI to Customer on an annual basis.

OTHER QUALIFIED VERSIONS OF CD54HC4066, CD74HC4066, CD74HCT4066 :

- Catalog : [CD74HC4066](#)

- Automotive : [CD74HCT4066-Q1](#)

- Military : [CD54HC4066](#)

NOTE: Qualified Version Definitions:

- Catalog - TI's standard catalog product

- Automotive - Q100 devices qualified for high-reliability automotive applications targeting zero defects

- Military - QML certified for Military and Defense Applications

J 14

GENERIC PACKAGE VIEW
CDIP - 5.08 mm max height
CERAMIC DUAL IN LINE PACKAGE



Images above are just a representation of the package family, actual package may vary.
Refer to the product data sheet for package details.

4040083-5/G

J0014A



PACKAGE OUTLINE

CDIP - 5.08 mm max height

CERAMIC DUAL IN LINE PACKAGE



4214771/A 05/2017

NOTES:

1. All controlling linear dimensions are in inches. Dimensions in brackets are in millimeters. Any dimension in brackets or parenthesis are for reference only. Dimensioning and tolerancing per ASME Y14.5M.
2. This drawing is subject to change without notice.
3. This package is hermetically sealed with a ceramic lid using glass frit.
4. Index point is provided on cap for terminal identification only and on press ceramic glass frit seal only.
5. Falls within MIL-STD-1835 and GDIP1-T14.

EXAMPLE BOARD LAYOUT

J0014A

CDIP - 5.08 mm max height

CERAMIC DUAL IN LINE PACKAGE



LAND PATTERN EXAMPLE
NON-SOLDER MASK DEFINED
SCALE: 5X



4214771/A 05/2017

D (R-PDSO-G14)

PLASTIC SMALL OUTLINE



- NOTES:
- A. All linear dimensions are in inches (millimeters).
 - B. This drawing is subject to change without notice.
 -  Body length does not include mold flash, protrusions, or gate burrs. Mold flash, protrusions, or gate burrs shall not exceed 0.006 (0,15) each side.
 -  Body width does not include interlead flash. Interlead flash shall not exceed 0.017 (0,43) each side.
 - E. Reference JEDEC MS-012 variation AB.

PW (R-PDSO-G14)

PLASTIC SMALL OUTLINE

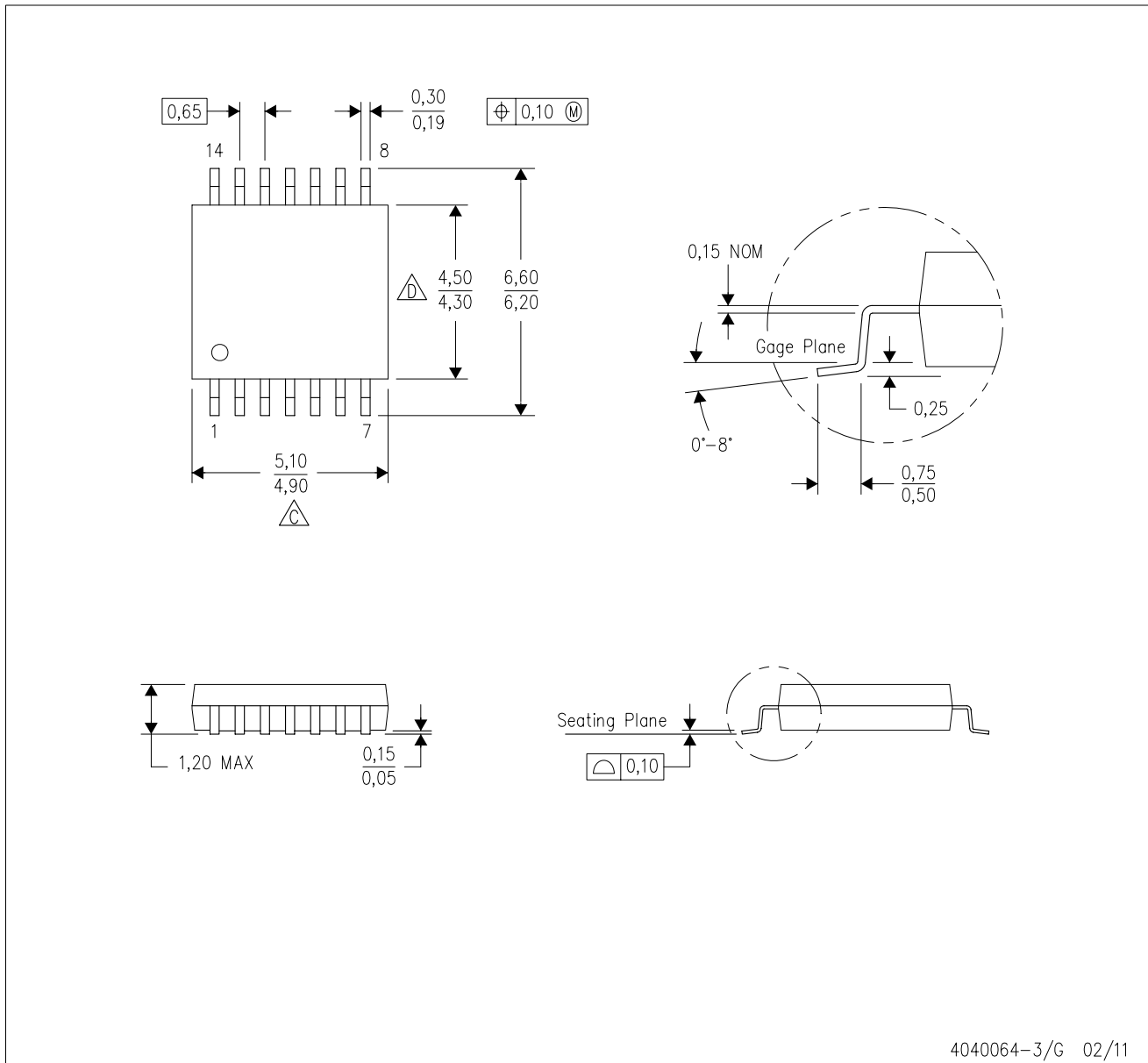

4040064-3/G 02/11

- NOTES:
- A. All linear dimensions are in millimeters. Dimensioning and tolerancing per ASME Y14.5M-1994.
 - B. This drawing is subject to change without notice.
 - C. Body length does not include mold flash, protrusions, or gate burrs. Mold flash, protrusions, or gate burrs shall not exceed 0,15 each side.
 - D. Body width does not include interlead flash. Interlead flash shall not exceed 0,25 each side.
 - E. Falls within JEDEC MO-153

N (R-PDIP-T**)

PLASTIC DUAL-IN-LINE PACKAGE

16 PINS SHOWN



- NOTES:
- A. All linear dimensions are in inches (millimeters).
 - B. This drawing is subject to change without notice.
 - Falls within JEDEC MS-001, except 18 and 20 pin minimum body length (Dim A).
 - The 20 pin end lead shoulder width is a vendor option, either half or full width.

IMPORTANT NOTICE AND DISCLAIMER

TI PROVIDES TECHNICAL AND RELIABILITY DATA (INCLUDING DATA SHEETS), DESIGN RESOURCES (INCLUDING REFERENCE DESIGNS), APPLICATION OR OTHER DESIGN ADVICE, WEB TOOLS, SAFETY INFORMATION, AND OTHER RESOURCES "AS IS" AND WITH ALL FAULTS, AND DISCLAIMS ALL WARRANTIES, EXPRESS AND IMPLIED, INCLUDING WITHOUT LIMITATION ANY IMPLIED WARRANTIES OF MERCHANTABILITY, FITNESS FOR A PARTICULAR PURPOSE OR NON-INFRINGEMENT OF THIRD PARTY INTELLECTUAL PROPERTY RIGHTS.

These resources are intended for skilled developers designing with TI products. You are solely responsible for (1) selecting the appropriate TI products for your application, (2) designing, validating and testing your application, and (3) ensuring your application meets applicable standards, and any other safety, security, regulatory or other requirements.

These resources are subject to change without notice. TI grants you permission to use these resources only for development of an application that uses the TI products described in the resource. Other reproduction and display of these resources is prohibited. No license is granted to any other TI intellectual property right or to any third party intellectual property right. TI disclaims responsibility for, and you will fully indemnify TI and its representatives against, any claims, damages, costs, losses, and liabilities arising out of your use of these resources.

TI's products are provided subject to [TI's Terms of Sale](#) or other applicable terms available either on [ti.com](https://www.ti.com) or provided in conjunction with such TI products. TI's provision of these resources does not expand or otherwise alter TI's applicable warranties or warranty disclaimers for TI products.

TI objects to and rejects any additional or different terms you may have proposed.

Mailing Address: Texas Instruments, Post Office Box 655303, Dallas, Texas 75265
Copyright © 2024, Texas Instruments Incorporated

Looking for pricing, stock, or lifecycle information?

Click below to explore more details on WIN SOURCE:

 [View CD54HC4066F3A](#) on WIN SOURCE

 [Texas Instruments](#) Information

Optimize Your Supply Chain with WIN SOURCE Solutions

-  Global Sourcing Solution
-  Obsolete Management
-  Cost Control Management
-  Shortage Management
-  Alternative Solution
-  Excess Inventory Management