



**THE DATASHEET OF  
MAX922MSA/PR+T**



## MAX921–MAX924

## Ultra Low-Power, Single/Dual-Supply Comparators

### General Description

The MAX921–MAX924 single, dual, and quad micro-power, low-voltage comparators feature the lowest power consumption available. These comparators draw less than 4µA supply current over temperature (MAX921/MAX922), and include an internal 1.182V ±1% voltage reference, programmable hysteresis, and TTL/CMOS outputs that sink and source current.

Ideal for 3V or 5V single-supply applications, the MAX921–MAX924 operate from a single +2.5V to +11V supply (or a ±1.25V to ±5V dual supply), and each comparator's input voltage range swings from the negative supply rail to within 1.3V of the positive supply.

The MAX921–MAX924's unique output stage continuously sources as much as 40mA. And by eliminating power-supply glitches that commonly occur when comparators change logic states, the MAX921–MAX924 minimize parasitic feedback, which makes them easier to use.

The single MAX921 and dual MAX923 provide a unique and simple method for adding hysteresis without feedback and complicated equations, simply by using the HYST pin and two resistors.

PART	INTERNAL 1% PRECISION REFERENCE	COMPARATORS PER PACKAGE	INTERNAL HYSTERESIS	PACKAGE
MAX921	Yes	1	Yes	8-Pin DIP/SO/µMAX
MAX922	No	2	No	8-Pin DIP/SO/µMAX
MAX923	Yes	2	Yes	8-Pin DIP/SO/µMAX
MAX924	Yes	4	No	16-Pin DIP/SO/µMAX

### Applications

- Battery-Powered Systems
- Threshold Detectors
- Window Comparators
- Oscillator Circuits

µMAX is a registered trademark of Maxim Integrated Products, Inc.

### Features

- µMAX® Package—Smallest 8-Pin SO (MAX921/MAX922/MAX923)
- Ultra-Low 4µA Max Quiescent Current Over Extended Temp. Range (MAX921)
- Power Supplies:
  - Single +2.5V to +11V
  - Dual ±1.25V to ±5.5V
- Input Voltage Range Includes Negative Supply
- Internal 1.182V ±1% Bandgap Reference
- Adjustable Hysteresis
- TTL/CMOS-Compatible Outputs
- 12µs Propagation Delay (10mV Overdrive)
- No Switching Crowbar Current
- 40mA Continuous Source Current

### Ordering Information

PART	TEMP RANGE	PIN-PACKAGE
MAX921CPA	0°C to +70°C	8 Plastic DIP
MAX921CSA	0°C to +70°C	8 SO
MAX921CUA	0°C to +70°C	8 µMAX
MAX921C/D	0°C to +70°C	Dice*
MAX921EPA	-40°C to +85°C	8 Plastic DIP
MAX921ESA	-40°C to +85°C	8 SO
MAX921MJA	-55°C to +125°C	8 CERDIP

Ordering Information continued at end of data sheet.

\*Dice are tested at  $T_A = +25^\circ\text{C}$ , DC parameters only.

\*\*Contact factory for availability.

### Typical Operating Circuit

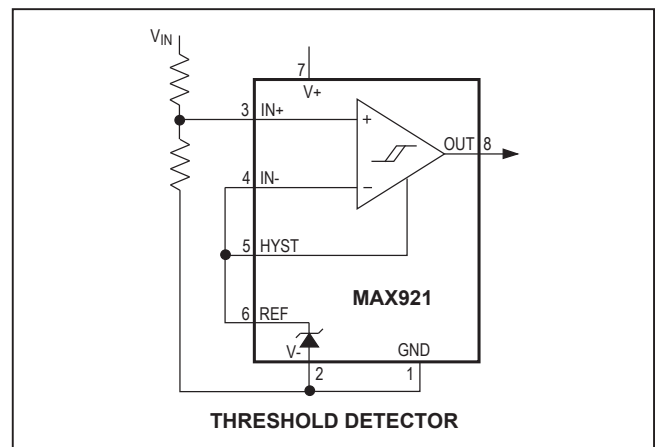

**Absolute Maximum Ratings**

V+ to V-, V+ to GND, GND to V-..... -0.3V, +12V  
**Inputs**  
 Current, IN\_+, IN\_-, HYST ..... 20mA  
 Voltage, IN\_+, IN\_-, HYST ..... (V+ + 0.3V) to (V- - 0.3V)  
**Outputs**  
 Current, REF ..... 20mA  
 Current, OUT\_ ..... 50mA  
 Voltage, REF ..... (V+ + 0.3V) to (V- - 0.3V)  
 Voltage, OUT\_ (MAX921/924)... (V+ + 0.3V) to (GND - 0.3V)  
 Voltage OUT\_ (MAX922/923)..... (V+ + 0.3V) to (V- - 0.3V)  
 OUT\_ Short-Circuit Duration (V+ ≤ 5.5V)..... Continuous

Continuous Power Dissipation (T<sub>A</sub> = +70°C)  
 8-Pin Plastic DIP (derate 9.09mW/°C above +70°C) ..727mW  
 8-Pin SO (derate 5.88mW/°C above +70°C).....471mW  
 8-Pin μMAX (derate 4.1mW/°C above +70°C).....330mW  
 8-Pin CERDIP (derate 8.00mW/°C above +70°C) .....640mW  
 16-Pin Plastic DIP (derate 10.53mW/°C above +70°C)... 842mW  
 16-Pin SO (derate 8.70mW/°C above +70°C).....696mW  
 16-Pin CERDIP (derate 10.00mW/°C above +70°C) ..800mW  
**Operating Temperature Ranges:**  
 MAX92\_C\_ ..... 0°C to +70°C  
 MAX92\_E\_ ..... -40°C to +85°C  
 MAX92\_MJ\_ ..... -55°C to +125°C  
**Storage Temperature Range** ..... -65°C to +150°C  
**Lead Temperature (soldering, 10s)** ..... +300°C

*Stresses beyond those listed under "Absolute Maximum Ratings" may cause permanent damage to the device. These are stress ratings only, and functional operation of the device at these or any other conditions beyond those indicated in the operational sections of the specifications is not implied. Exposure to absolute maximum rating conditions for extended periods may affect device reliability.*

**Electrical Characteristics : 5V OPERATION**

(V+ = 5V, V- = GND = 0V, T<sub>A</sub> = T<sub>MIN</sub> to T<sub>MAX</sub>, unless otherwise noted.)

PARAMETER	CONDITIONS		MIN	TYP	MAX	UNITS
<b>POWER REQUIREMENTS</b>						
Supply Voltage Range	(Note 1)		2.5		11	
Supply Current	IN+ = IN- + 100mV	MAX921, HYST = REF	T <sub>A</sub> = +25°C	2.5	3.2	V
			C/E temp. ranges		4	
			M temp. range		5	
		MAX922	T <sub>A</sub> = +25°C	2.5	3.2	
			C/E temp. ranges		4	
			M temp. range		5	
		MAX923, HYST = REF	T <sub>A</sub> = +25°C	3.1	4.5	
			C/E temp. ranges		6	
			M temp. range		7.5	
		MAX924	T <sub>A</sub> = +25°C	5.5	6.5	
			C/E temp. ranges		8.5	
			M temp. range		11	
<b>COMPARATOR</b>						
Input Offset Voltage	V <sub>CM</sub> = 2.5V				±10	mV
Input Leakage Current (IN-, IN+)	IN+ = IN- = 2.5V	C/E temp. ranges		±0.01	±5	nA
		M temp. range			±40	
Input Leakage Current (HYST)	MAX921, MAX923				±0.02	nA
Input Common-Mode Voltage Range			V-		V+ - 1.3	V
Common-Mode Rejection Ratio	V- to (V+ - 1.3V)			0.1	1.0	mV/V
Power-Supply Rejection Ratio	V+ = 2.5V to 11V			0.1	1.0	mV/V
Voltage Noise	100Hz to 100kHz			20		μV <sub>RMS</sub>
Hysteresis Input Voltage Range	MAX921, MAX923		REF - 0.05V		REF	V
Response Time	T <sub>A</sub> = +25°C, 100pF load	Overdrive = 10mV		12		μs
		Overdrive = 100mV		4		

**Electrical Characteristics : 5V OPERATION (continued)**

(V+ = 5V, V- = GND = 0V, T<sub>A</sub> = T<sub>MIN</sub> to T<sub>MAX</sub>, unless otherwise noted.)

PARAMETER	CONDITIONS		MIN	TYP	MAX	UNITS	
Output High Voltage	MAX92_	C/E temp. ranges: I <sub>OUT</sub> = 17mA; M temp. range: I <sub>OUT</sub> = 10mA	V+ – 0.4			V	
Output Low Voltage	MAX922/ MAX923	C/E temp. ranges: I <sub>OUT</sub> = 1.8mA; M temp. range: I <sub>OUT</sub> = 1.2mA			V- + 0.4	V	
	MAX921/ MAX924	C/E temp. ranges: I <sub>OUT</sub> = 1.8mA; M temp. range: I <sub>OUT</sub> = 1.2mA			GND + 0.4		
<b>REFERENCE (MAX921/MAX923/MAX924 ONLY)</b>							
Reference Voltage			C temp. range	1.170	1.182	1.194	V
			E temp. range	1.158		1.206	
			M temp. range	1.147		1.217	
Source Current			T <sub>A</sub> = +25°C	15	25		µA
			C/E temp. ranges	6			
			M temp. range	4			
Sink Current			T <sub>A</sub> = +25°C	8	15		µA
			C/E temp. ranges	4			
			M temp. range	2			
Voltage Noise	100Hz to 100kHz			100		µV <sub>RMS</sub>	

**Note 1:** MAX924 comparators work below 2.5V, see Low-Voltage Operation section for more details.

**Electrical Characteristics: 3V OPERATION**

(V+ = 3V, V- = GND = 0V, T<sub>A</sub> = T<sub>MIN</sub> to T<sub>MAX</sub>, unless otherwise noted.)

PARAMETER	CONDITIONS		MIN	TYP	MAX	UNITS
<b>POWER REQUIREMENTS</b>						
Supply Current	HYST = REF, IN+ = (IN- + 100mV)	MAX921	T <sub>A</sub> = +25°C	2.4	3.0	µA
			C/E temp. ranges		3.8	
			M temp. range		4.8	
		MAX922	T <sub>A</sub> = +25°C	2.4	3.0	
			C/E temp. ranges		3.8	
			M temp. range		4.8	
		MAX923	T <sub>A</sub> = +25°C	3.4	4.3	
			C/E temp. ranges		5.8	
			M temp. range		7.2	
		MAX924	T <sub>A</sub> = +25°C	5.2	6.2	
			C/E temp. ranges		8.0	
			M temp. range		10.5	
<b>COMPARATOR</b>						
Input Offset Voltage	V <sub>CM</sub> = 1.5V				±10	mV
Input Leakage Current (IN-, IN+)	IN+ = IN- = 2.5V		C/E temp. ranges	±0.01	±5	nA
			M temp. range		±40	
Input Leakage Current (HYST)	MAX921, MAX923			±0.02		nA

**Electrical Characteristics (continued)**

(V+ = 3V, V- = GND = 0V, TA = TMIN to TMAX, unless otherwise noted.)

PARAMETER	CONDITIONS		MIN	TYP	MAX	UNITS	
Input Common-Mode Voltage Range			V-	V+ – 1.3		V	
Common-Mode Rejection Ratio	V- to (V+ – 1.3V)			0.2	1	mV/V	
Power-Supply Rejection Ratio	V+ = 2.5V to 11V			0.1	1	mV/V	
Voltage Noise	100Hz to 100kHz			20		μVRMS	
Hysteresis Input Voltage Range	MAX921, MAX923		REF- 0.05V		REF	V	
Response Time	TA = +25°C, 100pF load	Overdrive = 10mV		14		μs	
		Overdrive = 100mV		5			
Output High Voltage	MAX92_	C/E temp. ranges: IOUT = 10mA; M temp. range: IOUT = 6mA	V+ – 0.4			V	
Output Low Voltage	MAX922/ MAX923	C/E temp. ranges: IOUT = 0.8mA; M temp. range: IOUT = 0.6mA			V- + 0.4	V	
	MAX921/ MAX924	C/E temp. ranges: IOUT = 0.8mA; M temp. range: IOUT = 0.6mA			GND + 0.4		
<b>REFERENCE</b>							
Reference Voltage			C temp. range	1.170	1.182	1.194	V
			E temp. range	1.158		1.206	
			M temp. range	1.147		1.217	
Source Current			TA = +25°C	15	25		μA
			C/E temp. ranges	6			
			M temp. range	4			
Sink Current			TA = +25°C	8	15		μA
			C/E temp. ranges	4			
			M temp. range	2			
Voltage Noise	100Hz to 100kHz			100		μVRMS	

**Typical Operating Characteristics**

(V+ = 5V, V- = GND, TA = +25°C, unless otherwise noted).

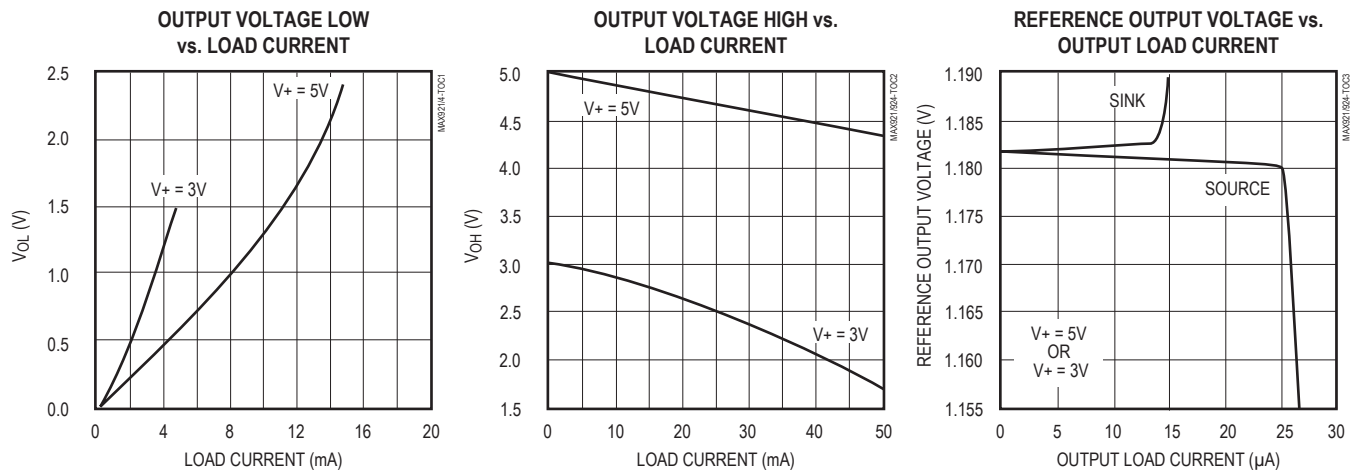

Typical Operating Characteristics (continued)

( $V_+ = 5V$ ,  $V_- = GND$ ,  $T_A = +25^\circ C$ , unless otherwise noted).

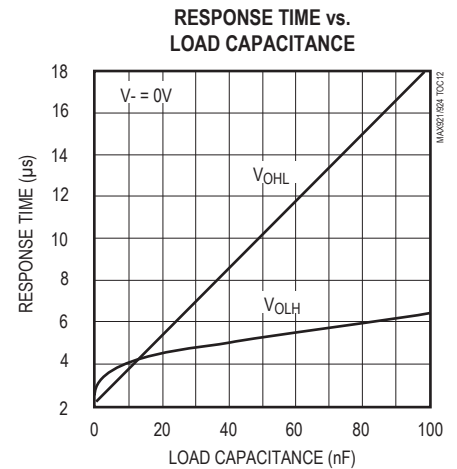
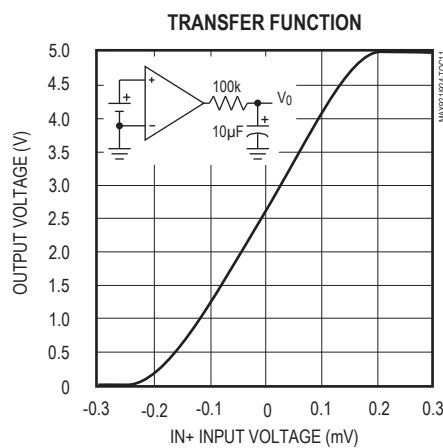
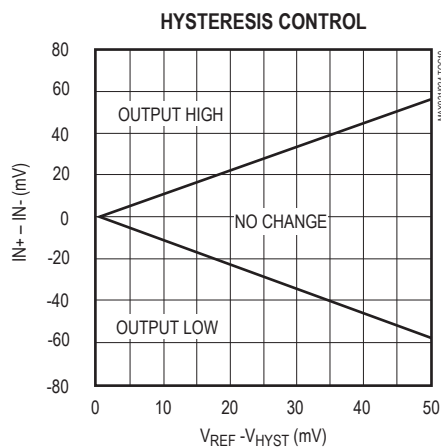
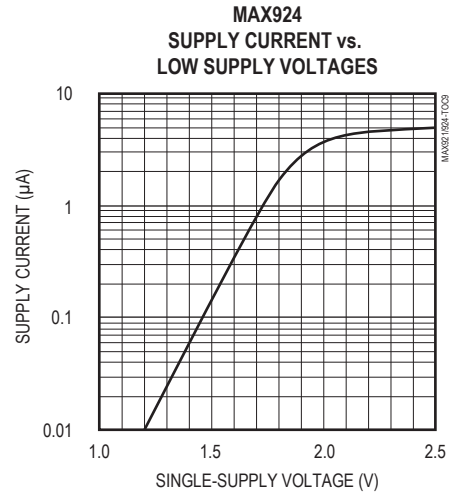
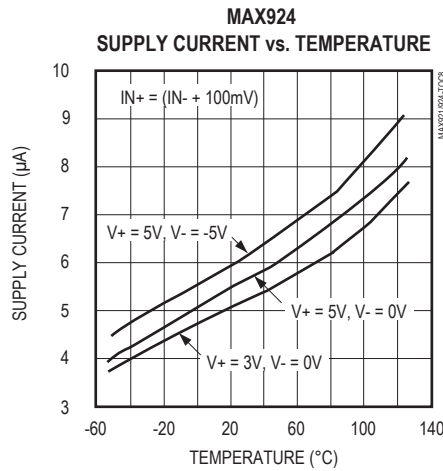
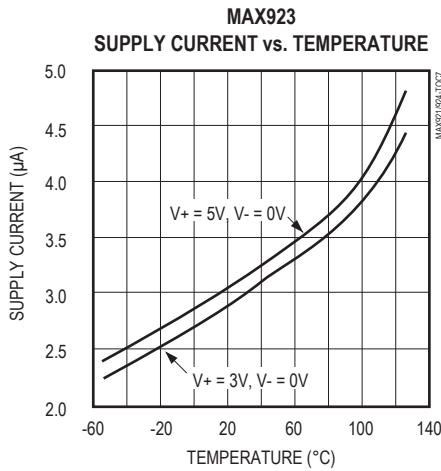
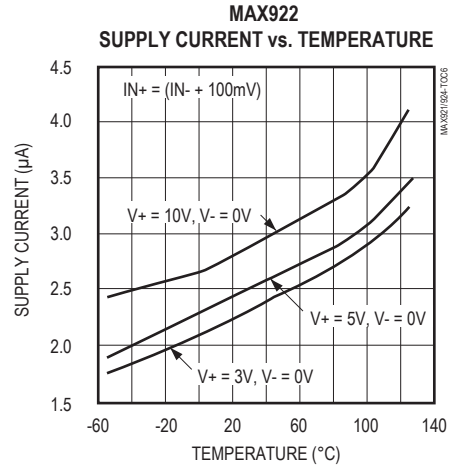
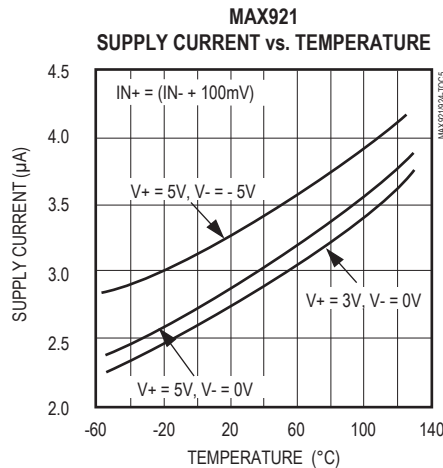
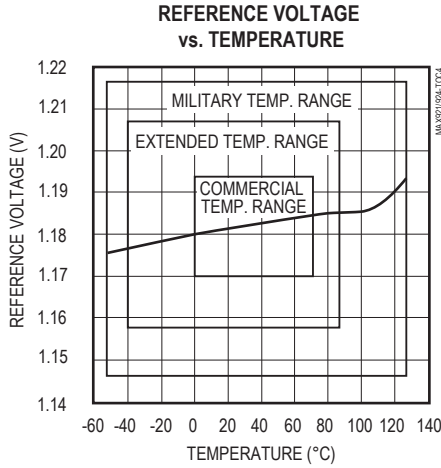

Typical Operating Characteristics (continued)

(V+ = 5V, V- = GND, T<sub>A</sub> = +25°C, unless otherwise noted).

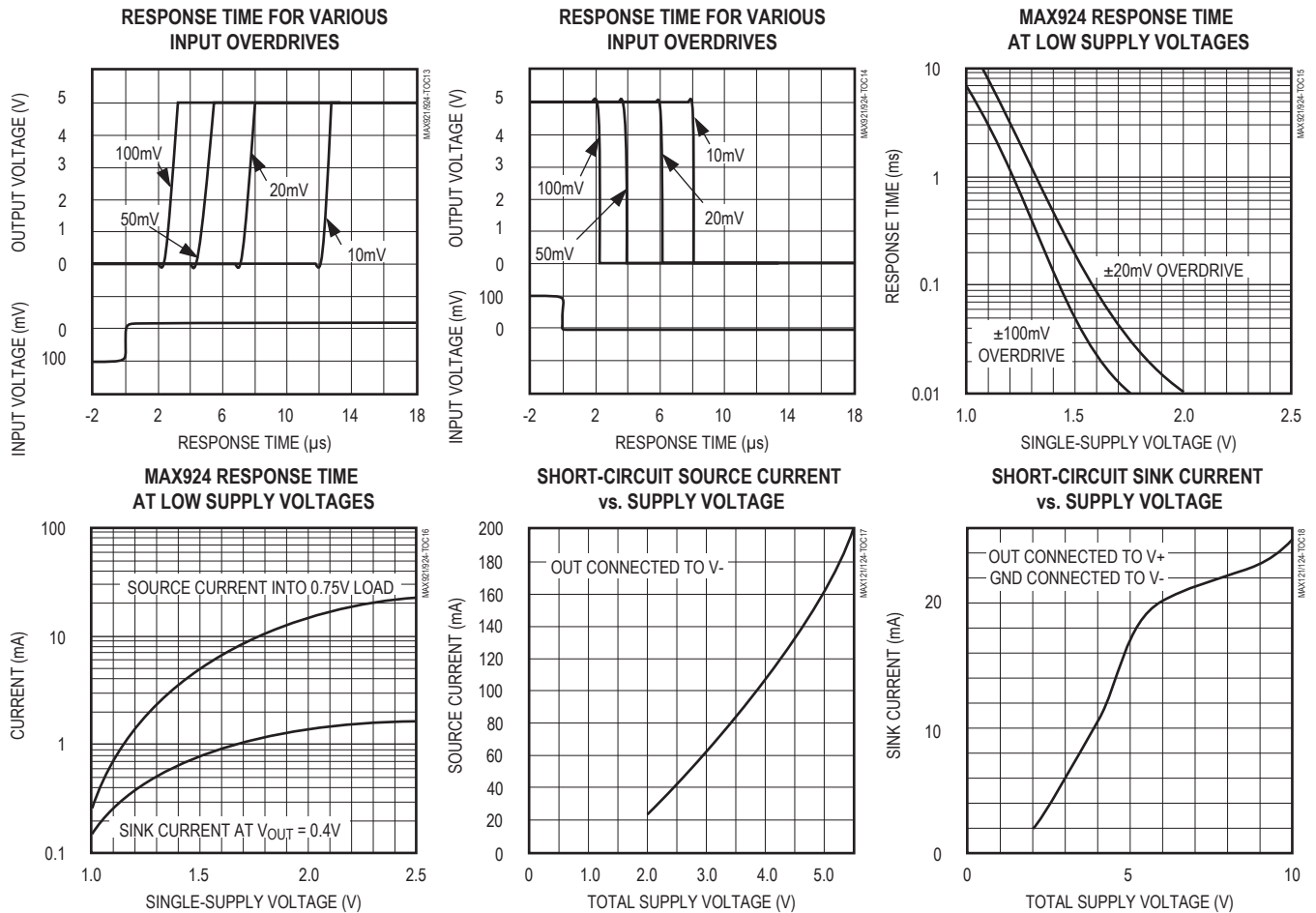

Pin Descriptions

PIN			NAME	FUNCTION
MAX921	MAX922	MAX923		
1	–	–	GND	Ground. Connect to V- for single-supply operation. Output swings from V+ to GND.
–	1	1	OUTA	Comparator A output. Sinks and sources current. Swings from V+ to V-.
2	2	2	V-	Negative supply. Connect to ground for single-supply operation (MAX921).
3	–	–	IN+	Noninverting comparator input
–	3	3	INA+	Noninverting input of comparator A
4	–	–	IN-	Inverting comparator input
–	4	–	INA-	Inverting input of comparator A

## Pin Descriptions (continued)

PIN			NAME	FUNCTION
MAX921	MAX922	MAX923		
–	5	4	INB-	Inverting input of comparator B
5	–	5	HYST	Hysteresis input. Connect to REF if not used. Input voltage range is from $V_{REF}$ to $V_{REF} - 50mV$ .
6	–	6	REF	Reference output. 1.182V with respect to V-.
–	6	–	INB+	Noninverting input of comparator B
7	7	7	V+	Positive supply
8	–	–	OUT	Comparator output. Sinks and sources current. Swings from V+ to GND.
–	8	8	OUTB	Comparator B output. Sinks and sources current. Swings from V+ to V-.

PIN MAX924	NAME	FUNCTION
1	OUTB	Comparator B output. Sinks and sources current. Swings from V+ to GND.
2	OUTA	Comparator A output. Sinks and sources current. Swings from V+ to GND.
3	V+	Positive supply
4	INA-	Inverting input of comparator A
5	INA+	Noninverting input of comparator A
6	INB-	Inverting input of comparator B
7	INB+	Noninverting input of comparator B
8	REF	Reference output. 1.182V with respect to V-.
9	V-	Negative supply. Connect to ground for single-supply operation.
10	INC-	Inverting input of comparator C
11	INC+	Noninverting input of comparator C
12	IND-	Inverting input of comparator D
13	IND+	Noninverting input of comparator D
14	GND	Ground. Connect to V- for single-supply operation.
15	OUTD	Comparator D output. Sinks and sources current. Swings from V+ to GND.
16	OUTC	Comparator C output. Sinks and sources current. Swings from V+ to GND.

**Detailed Description**

The MAX921–MAX924 comprise various combinations of a micropower 1.182V reference and a micropower comparator. The *Typical Operating Circuit* shows the MAX921 configuration, and Figures 1a-1c show the MAX922–MAX924 configurations.

Each comparator continuously sources up to 40mA, and the unique output stage eliminates crowbar glitches during output transitions. This makes them immune to parasitic feedback (which can cause instability) and provides excellent performance, even when circuit-board layout is not optimal.

Internal hysteresis in the MAX921 and MAX923 provides the easiest method for implementing hysteresis. It also produces faster hysteresis action and consumes much less current than circuits using external positive feedback.

**Power-Supply and Input Signal Ranges**

This family of devices operates from a single +2.5V to +11V power supply. The MAX921 and MAX924 have a

separate ground for the output driver, allowing operation with dual supplies ranging from ±1.25V to ±5.5V. Connect V- to GND when operating the MAX921 and the MAX924 from a single supply. The maximum supply voltage in this case is still 11V.

For proper comparator operation, the input signal can swing from the negative supply (V-) to within one volt of the positive supply (V+ – 1V). The guaranteed common-mode input voltage range extends from V- to (V+ - 1.3V). The inputs can be taken above and below the supply rails by up to 300mV without damage.

Operating the MAX921 and MAX924 at ±5V provides TTL/CMOS compatibility when monitoring bipolar input signals. TTL compatibility for the MAX922 and MAX923 is achieved by operation from a single +5V supply.

**Low-Voltage Operation: V+ = 1V (MAX924 Only)**

The guaranteed minimum operating voltage is 2.5V (or ±1.25V). As the total supply voltage is reduced below 2.5V, the performance degrades and the supply current falls. The reference will not function below about 2.2V,

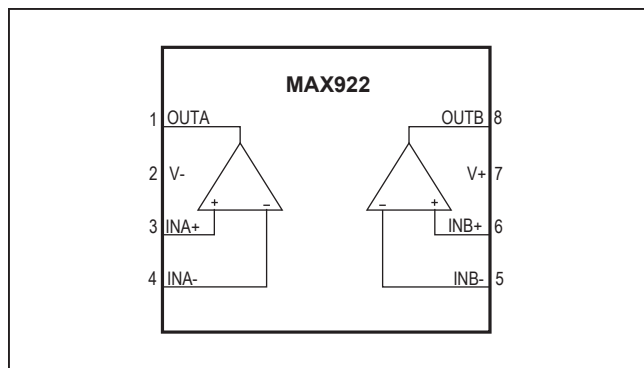
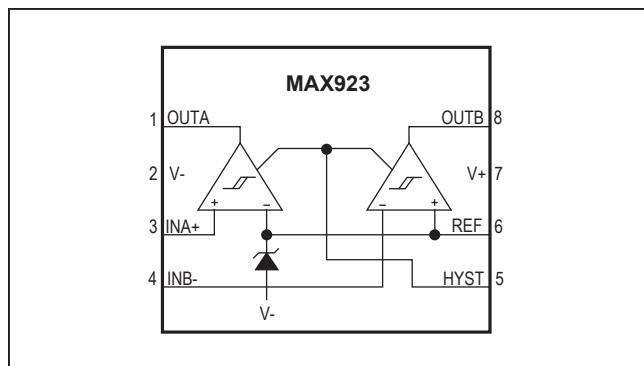
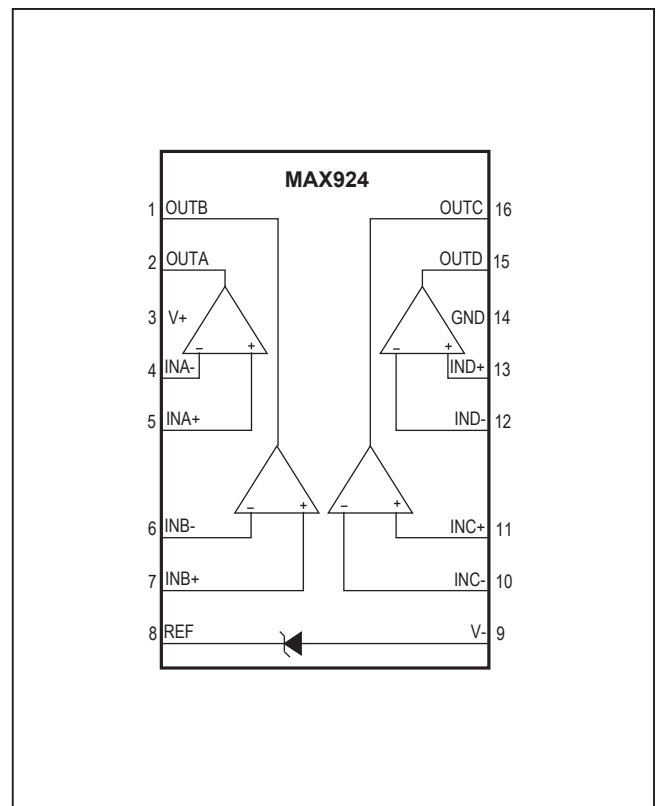

Figure 1a. MAX922 Functional Diagram



1b. MAX923 Functional Diagram



1c. MAX924 Functional Diagram

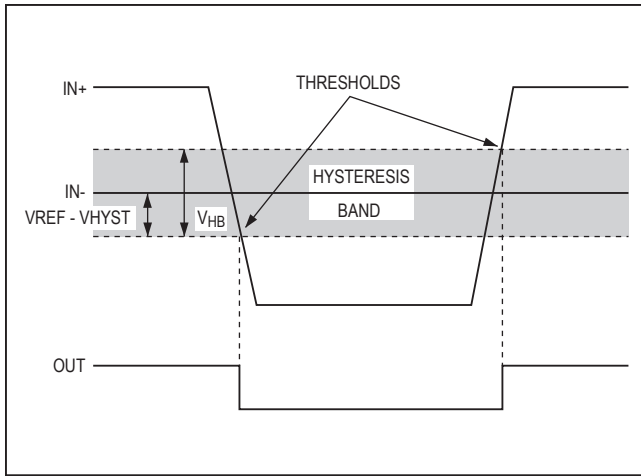

Figure 2. Threshold Hysteresis Band

although the comparators will continue to operate with a total supply voltage as low as 1V. While the MAX924 has comparators that may be used at supply voltages below 2V, the MAX921, MAX922, and MAX923 may not be used with supply voltages significantly below 2.5V.

At low supply voltages, the comparators' output drive is reduced and the propagation delay increases (see *Typical Operating Characteristics*). The useful input voltage range extends from the negative supply to a little under 1V below the positive supply, which is slightly closer to the positive rail than the device operating from higher supply voltages. Test your prototype over the full temperature and supply-voltage range if operation below 2.5V is anticipated.

### Comparator Output

With 100mV of overdrive, propagation delay is typically 3μs. The *Typical Operating Characteristics* show the propagation delay for various overdrive levels.

The MAX921 and MAX924 output swings from V+ to GND, so TTL compatibility is assured by using a +5V ±10% supply. The negative supply does not affect the output swing, and can range from 0V to -5V ±10%.

The MAX922 and MAX923 have no GND pin, and their outputs swing from V+ to V-. Connect V- to ground and V+ to a +5V supply to achieve TTL compatibility.

The MAX921–MAX924's unique design achieves an output source current of more than 40mA and a sink current of over 5mA, while keeping quiescent currents in the microampere range. The output can source 100mA (at V+ = 5V) for short pulses, as long as the package's maximum power dissipation is not exceeded. The output stage does not generate crowbar switching currents during transitions, which minimizes feedback through the supplies and helps ensure stability without bypassing.

### Voltage Reference

The internal bandgap voltage reference has an output of 1.182V above V-. Note that the REF voltage is referenced to V-, not to GND. Its accuracy is ±1% in the range 0°C to +70°C. The REF output is typically capable of sourcing 15μA and sinking 8μA. Do not bypass the REF output.

### Noise Considerations

Although the comparators have a very high gain, useful gain is limited by noise. This is shown in the Transfer Function graph (see *Typical Operating Characteristics*). As the input voltage approaches the comparator's offset, the output begins to bounce back and forth; this peaks when  $V_{IN} = V_{OS}$ . (The lowpass filter shown on the graph averages out the bouncing, making the transfer function easy to observe.) Consequently, the comparator has an effective wideband peak-to-peak noise of around 0.3mV. The voltage reference has peak-to-peak noise approaching 1mV. Thus, when a comparator is used with the reference, the combined peak-to-peak noise is about 1mV. This, of

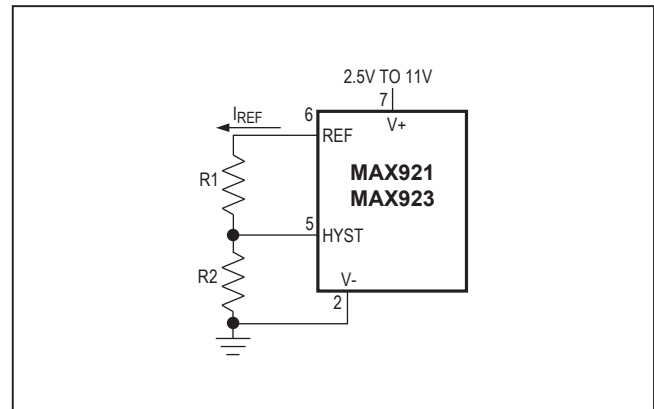

Figure 3. Programming the HYST Pin

course, is much higher than the RMS noise of the individual components. Care should be taken in the layout to avoid capacitive coupling from any output to the reference pin. Crosstalk can significantly increase the actual noise of the reference.

### Applications Information

#### Hysteresis

Hysteresis increases the comparators' noise margin by increasing the upper threshold and decreasing the lower threshold (see Figure 2).

#### Hysteresis (MAX921/MAX923)

To add hysteresis to the MAX921 or MAX923, connect resistor R1 between REF and HYST, and connect resistor R2 between HYST and V- (Figure 3). If no hysteresis is required, connect HYST to REF. When hysteresis is added, the upper threshold increases by the same amount that the lower threshold decreases. The hysteresis band (the difference between the upper and lower thresholds,  $V_{HB}$ ) is approximately equal to twice the voltage between REF and HYST. The HYST input can be adjusted to a maximum voltage of REF and to a minimum voltage of (REF – 50mV). The maximum difference between REF and HYST (50mV) will therefore produce a 100mV max hysteresis band. Use the following equations to determine R1 and R2:

$$R1 = \frac{V_{HB}}{(2 \times I_{REF})}$$

$$R2 = \frac{\left(1.182 - \frac{V_{HB}}{2}\right)}{I_{REF}}$$

Where  $I_{REF}$  (the current sourced by the reference) should not exceed the REF source capability, and should be significantly larger than the HYST input current.  $I_{REF}$  values between 0.1µA and 4µA are usually appropriate. If 2.4MΩ is chosen for R2 ( $I_{REF} = 0.5\mu A$ ), the equation for R1 and  $V_{HB}$  can be approximated as:

$$R1 (k\Omega) = V_{HB}(mV)$$

When hysteresis is obtained in this manner for the MAX923, the same hysteresis applies to both comparators.

#### Hysteresis (MAX922/MAX924)

Hysteresis can be set with two resistors using positive feedback, as shown in Figure 4. This circuit generally draws more current than the circuits using the HYST pin on

the MAX921 and MAX923, and the high feedback impedance slows hysteresis. The design procedure is as follows:

- 1) Choose R3. The leakage current of IN+ is under 1nA (up to +85°C), so the current through R3 can be around 100nA and still maintain good accuracy. The current through R3 at the trip point is  $V_{REF}/R3$ , or 100nA for  $R3 = 11.8M\Omega$ . 10MΩ is a good practical value.
- 2) Choose the hysteresis voltage ( $V_{HB}$ ), the voltage between the upper and lower thresholds. In this example, choose  $V_{HB} = 50mV$ .
- 3) Calculate R1.

$$R1 = R3 \times \frac{V_{HB}}{V_+}$$

$$= 10M \times \frac{0.05}{5}$$

$$= 100k\Omega$$

- 4) Choose the threshold voltage for  $V_{IN}$  rising ( $V_{THR}$ ). In this example, choose  $V_{THR} = 3V$ .
- 5) Calculate R2.

$$R2 = \frac{1}{\left[\left(\frac{V_{THR}}{(V_{REF} \times R1)}\right) - \frac{1}{R1} - \frac{1}{R3}\right]}$$

$$= \frac{1}{\left[\left(\frac{3}{(1.182 \times 100k)}\right) - \frac{1}{100k} - \frac{1}{10M}\right]}$$

$$= 65.44k\Omega$$

A 1% preferred value is 64.9kΩ.

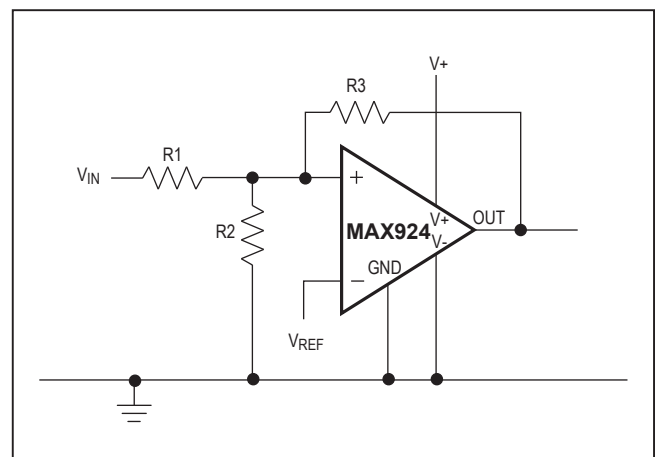

Figure 4. External Hysteresis

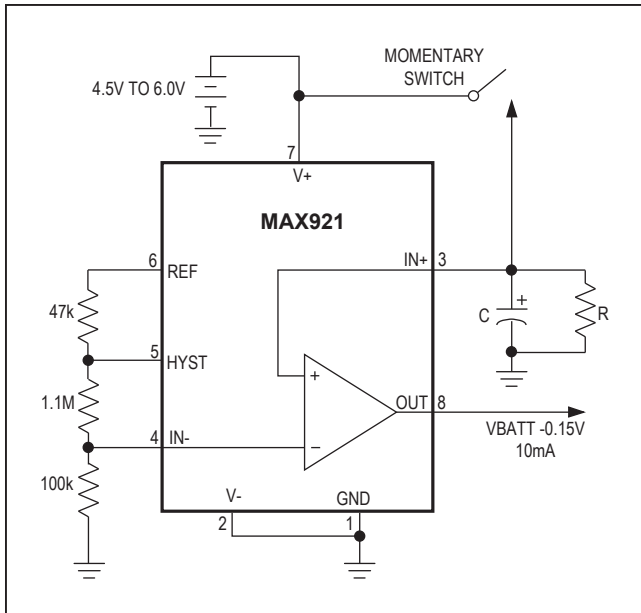

Figure 5. Auto-off power switch operates on 2.5µA quiescent current.

### Typical Applications

#### Auto-Off Power Source

Figure 5 shows the schematic for a 40mA power supply that has a timed auto power-off function. The comparator output is the switched power-supply output. With a 10mA load, it typically provides a voltage of (V<sub>BATT</sub> – 0.12V), but draws only 3.5µA quiescent current. This circuit takes advantage of the four key features of the MAX921: 2.5µA supply current, an internal reference, hysteresis, and high current output. Using the component values shown, the three-resistor voltage divider programs the maximum ±50mV of hysteresis and sets the IN- voltage at 100mV. This gives an IN+ trip threshold of approximately 50mV for IN+ falling.

The RC time constant determines the maximum power on time of the OUT pin before power-down occurs. This period can be approximated by:

$$R \times C \times 4.6\text{sec}$$

For example: 2MΩ x 10µF x 4.6 = 92sec. The actual time will vary with both the leakage current of the capacitor and the voltage applied to the circuit.

#### Window Detector

The MAX923 is ideal for making window detectors (undervoltage/ overvoltage detectors). The schematic is shown in Figure 6, with component values selected for an 4.5V undervoltage threshold, and a 5.5V overvoltage threshold. Choose different thresholds by changing the values of R1, R2, and R3. To prevent chatter at the output when the supply voltage is close to a threshold, hysteresis has been added using R4 and R5. OUTA provides an active-low undervoltage indication, and OUTB gives an active-low overvoltage indication. ANDing the two outputs provides an active-high, power-good signal.

The design procedure is as follows:

- 1) Choose the required hysteresis level and calculate values for R4 and R5 according to the formulas in the *Hysteresis (MAX921/MAX923)* section. In this example, ±5mV of hysteresis has been added at the comparator input (V<sub>H</sub> = V<sub>HB</sub>/2). This means that the hysteresis apparent at V<sub>IN</sub> will be larger because of the input resistor divider.

- 6) Verify the threshold voltages with these formulas:

V<sub>IN</sub> rising:

$$V_{THR} = V_{REF} \times R1 \times \left( \frac{1}{R1} + \frac{1}{R2} + \frac{1}{R3} \right)$$

V<sub>IN</sub> falling:

$$V_{THF} = V_{THR} - \frac{(R1 \times V+)}{R3}$$

#### Board Layout and Bypassing

Power-supply bypass capacitors are not needed if the supply impedance is low, but 100nF bypass capacitors should be used when the supply impedance is high or when the supply leads are long. Minimize signal lead lengths to reduce stray capacitance between the input and output that might cause instability. Do not bypass the reference output.

- 2) Select R1. The leakage current into INB- is normally under 1nA, so the current through R1 should exceed 100nA for the thresholds to be accurate. R1 values up to about 10MΩ can be used, but values in the 100kΩ to 1MΩ range are usually easier to deal with. In this example, choose R1 = 294kΩ.
- 3) Calculate R2 + R3. The overvoltage threshold should be 5.5V when VIN is rising. The design equation is as follows:

$$\begin{aligned}
 R2 + R3 &= R1 \times \left( \frac{V_{OTH}}{V_{REF} + V_H} - 1 \right) \\
 &= 294k \times \left( \frac{5.5}{(1.182 + 0.005)} - 1 \right) \\
 &= 1.068M\Omega
 \end{aligned}$$

Calculate R2. The undervoltage threshold should be 4.5V when VIN is falling. The design equation is as follows:

$$\begin{aligned}
 R2 &= (R1 + R2 + R3) \times \frac{(V_{REF} - V_H)}{V_{UTH}} - R1 \\
 &= (294k + 1.068M) \times \frac{(1.182 - 0.005)}{4.5} - 294k \\
 &= 62.2k\Omega
 \end{aligned}$$

Choose R2 = 61.9kΩ (1% standard value).

- 4) Calculate R3.

$$\begin{aligned}
 R3 &= (R2 + R3) - R2 \\
 &= 1.068M - 61.9k \\
 &= 1.006M\Omega
 \end{aligned}$$

Choose R3 = 1MΩ (1% standard value).

Verify the resistor values. The equations are as follows, evaluated for the above example.

Overvoltage threshold:

$$\begin{aligned}
 V_{OTH} &= (V_{REF} + V_H) \times \frac{(R1 + R2 + R3)}{R1} \\
 &= 5.474V.
 \end{aligned}$$

Undervoltage threshold:

$$\begin{aligned}
 V_{UTH} &= (V_{REF} - V_H) \times \frac{(R1 + R2 + R3)}{(R1 + R2)} \\
 &= 4.484V,
 \end{aligned}$$

where the hysteresis voltage  $V_H = V_{REF} \times \frac{R5}{R4}$ .

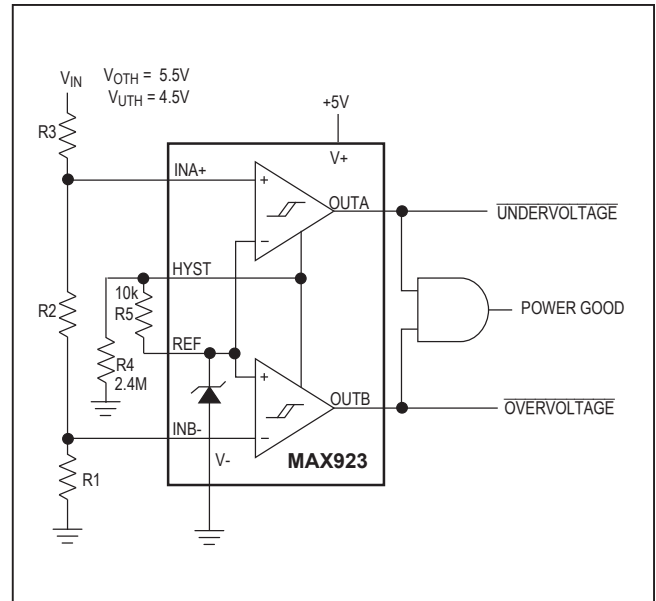

Figure 6. Window Detector

### Bar-Graph Level Gauge

The high output source capability of the MAX921 series is useful for driving LEDs. An example of this is the simple four-stage level detector shown in Figure 7. The full-scale threshold (all LEDs on) is given by  $V_{IN} = (R1 + R2)/R1$  volts. The other thresholds are at 3/4 full scale, 1/2 full scale, and 1/4 full scale. The output resistors limit the current into the LEDs.

### Level Shifter

Figure 8 shows a circuit to shift from bipolar ±5V inputs to TTL signals. The 10kΩ resistors protect the comparator inputs, and do not materially affect the operation of the circuit.

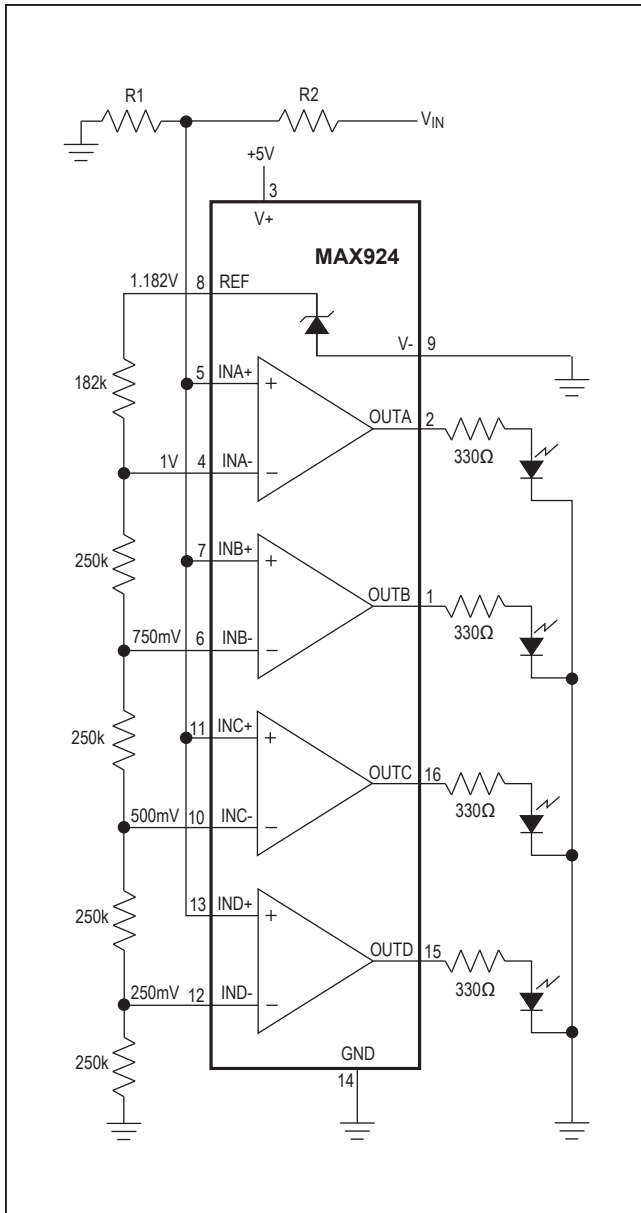

Figure 7. Bar-Graph Level Gauge

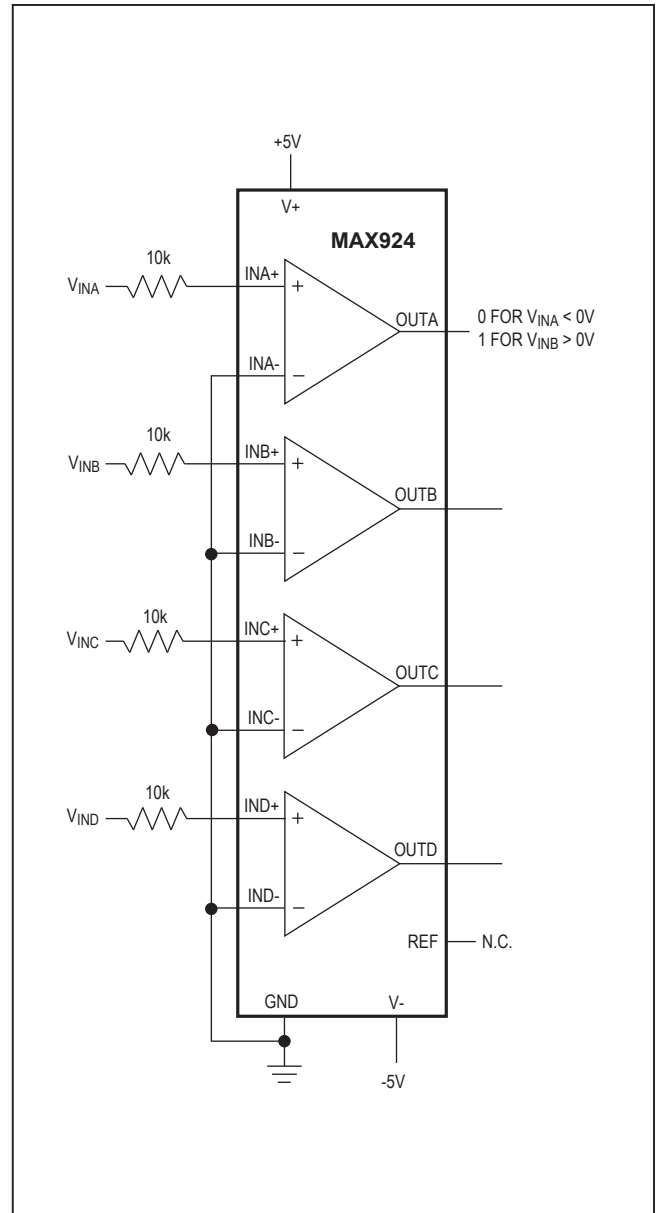
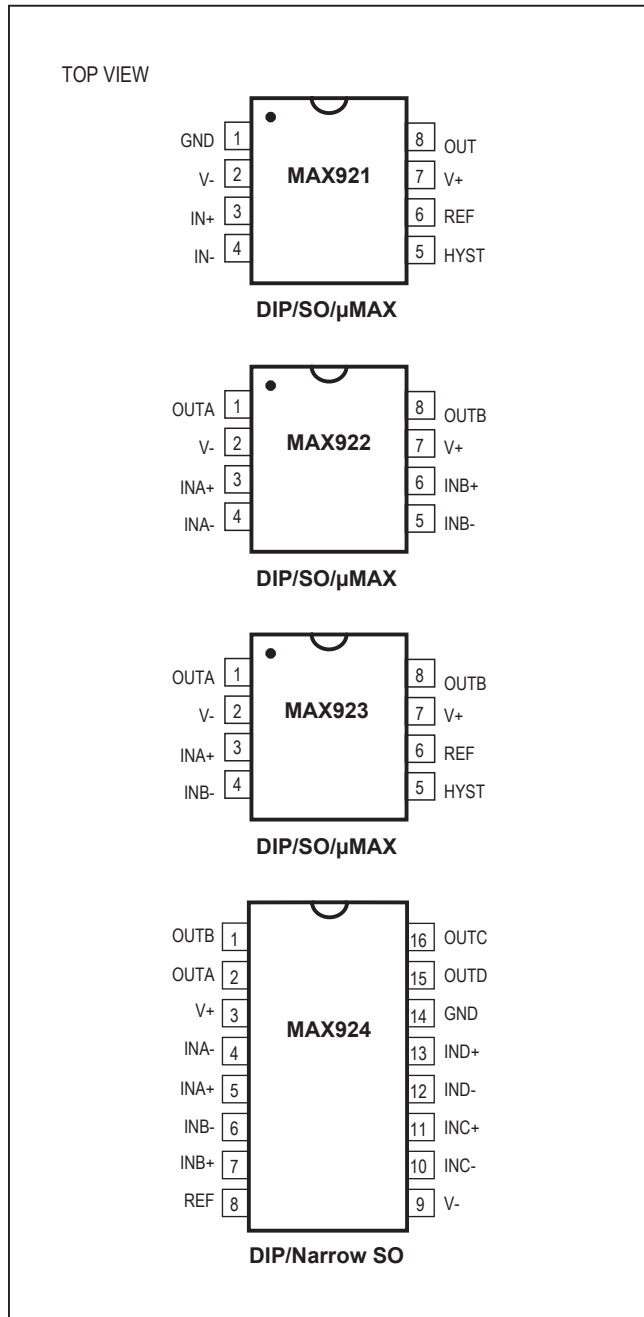

Figure 8. Level Shifter: ±5V Input to CMOS Output

Pin Configurations



Ordering Information (continued)

PART	TEMP RANGE	PIN-PACKAGE
MAX921MSA/PR	-55°C to +125°C	8 SO**
MAX921MSA/PR-T	-55°C to +125°C	8 SO**
<b>MAX922CPA</b>	0°C to +70°C	8 Plastic DIP
MAX922CSA	0°C to +70°C	8 SO
MAX922CUA	0°C to +70°C	8 $\mu$ MAX
MAX922C/D	0°C to +70°C	Dice*
MAX922EPA	-40°C to +85°C	8 Plastic DIP
MAX922ESA	-40°C to +85°C	8 SO
MAX922MJA	-55°C to +125°C	8 CERDIP**
MAX922MSA/PR	-55°C to +125°C	8 SO**
MAX922MSA/PR-T	-55°C to +125°C	8 SO**
<b>MAX923CPA</b>	0°C to +70°C	8 Plastic DIP
MAX923CSA	0°C to +70°C	8 SO
MAX923CUA	0°C to +70°C	8 $\mu$ MAX
MAX923C/D	0°C to +70°C	Dice*
MAX923EPA	-40°C to +85°C	8 Plastic DIP
MAX923ESA	-40°C to +85°C	8 SO
MAX923MJA	-55°C to +125°C	8 CERDIP**
MAX923MSA/PR	-55°C to +125°C	8 SO**
MAX923MSA/PR-T	-55°C to +125°C	8 SO**
<b>MAX924CPE</b>	0°C to +70°C	16 Plastic DIP
MAX924CSE	0°C to +70°C	16 Narrow SO
MAX924C/D	0°C to +70°C	Dice*
MAX924EPE	-40°C to +85°C	16 Plastic DIP
MAX924ESE	-40°C to +85°C	16 Narrow SO
MAX924MJE	-55°C to +125°C	16 CERDIP**
MAX924MSE/PR	-55°C to +125°C	16 Narrow SO**
MAX924MSE/PR-T	-55°C to +125°C	16 Narrow SO**

\*Dice are tested at  $T_A = +25^\circ\text{C}$ , DC parameters only.  
\*\*Contact factory for availability.

Chip Topographies

MAX921/MAX922/MAX923

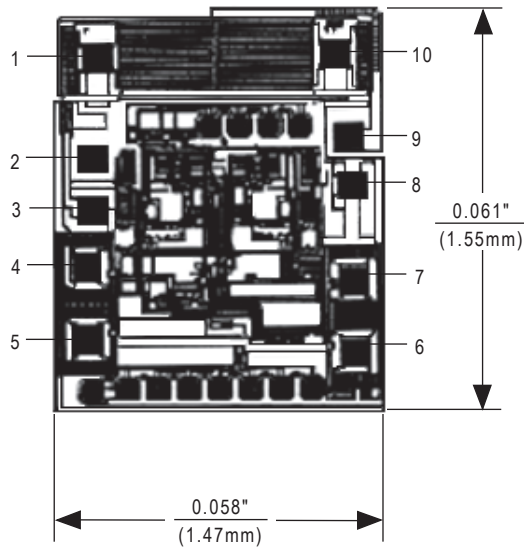

DIE PAD	MAX921	MAX922	MAX923
1	GND	OUTA	OUTA
2	V-	V-	V-
3	V-	V-	V-
4	IN+	INA+	INA+
5	IN-	INA-	INB-
6	HYST	INB-	HYST
7	REF	INB+	REF
8	V+	V+	V+
9	V+	V+	V+
10	OUT	OUTB	OUTB

TRANSISTOR COUNT: 164  
SUBSTRATE CONNECTED TO V+

MAX924

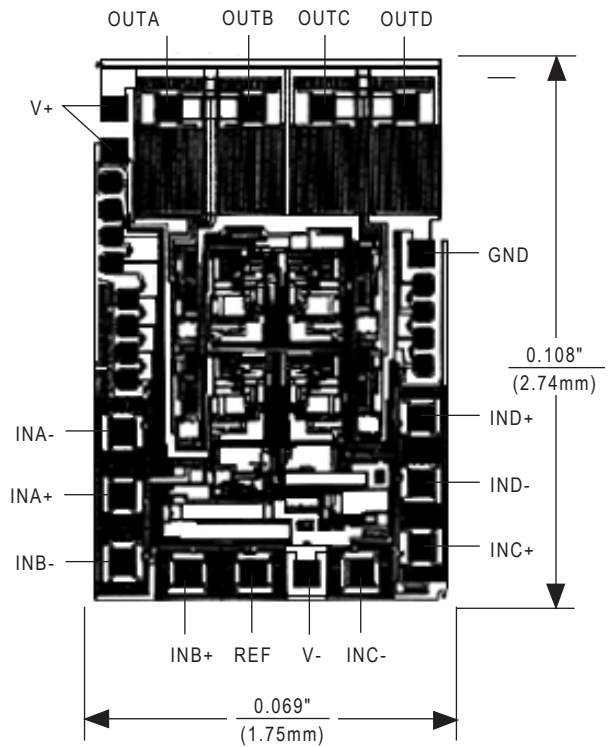

TRANSISTOR COUNT: 267  
SUBSTRATE CONNECTED TO V+

## Package Information

For the latest package outline information and land patterns (footprints), go to [www.maximintegrated.com/packages](http://www.maximintegrated.com/packages). Note that a "+", "#", or "-" in the package code indicates RoHS status only. Package drawings may show a different suffix character, but the drawing pertains to the package regardless of RoHS status.

PACKAGE TYPE	PACKAGE CODE	DOCUMENT NO.
8 Plastic DIP	P8-1	<a href="#">21-0043</a>
16 Plastic DIP	P16-1	<a href="#">21-0043</a>
8 SO	S8-2	<a href="#">21-0041</a>
16 SO	S16-3	<a href="#">21-0041</a>
8 $\mu$ MAX	U8-1	<a href="#">21-0036</a>
8 CERDIP	J8-1	<a href="#">21-0045</a>
16 CERDIP	J16-3-1	<a href="#">21-0045</a>

## Revision History

REVISION NUMBER	REVISION DATE	DESCRIPTION	PAGES CHANGED
4	8/08	Updated TOCs 5 and 10	5
5	8/08	Adding information for rugged plastic product	1, 14
6	4/09	Updated <i>Ordering Information</i>	1, 14, 16
7	1/20	Updated <i>Chip Topographies</i>	15

For pricing, delivery, and ordering information, please visit Maxim Integrated's online storefront at <https://www.maximintegrated.com/en/storefront/storefront.html>.

*Maxim Integrated cannot assume responsibility for use of any circuitry other than circuitry entirely embodied in a Maxim Integrated product. No circuit patent licenses are implied. Maxim Integrated reserves the right to change the circuitry and specifications without notice at any time. The parametric values (min and max limits) shown in the Electrical Characteristics table are guaranteed. Other parametric values quoted in this data sheet are provided for guidance.*

## Looking for pricing, stock, or lifecycle information?

Click below to explore more details on WIN SOURCE:

- ⊖ [View MAX922MSA/PR+T on WIN SOURCE](#)
- ⊖ [Maxim Integrated Information](#)

## Optimize Your Supply Chain with WIN SOURCE Solutions

- ✓ Global Sourcing Solution
- ✓ Obsolete Management
- ✓ Cost Control Management
- ✓ Shortage Management
- ✓ Alternative Solution
- ✓ Excess Inventory Management