



**THE DATASHEET OF
CD4541BM96**



CMOS Programmable Timer High Voltage Types (20V Rating)

Features

- Low Symmetrical Output Resistance, Typically 100Ω at V_{DD} = 15V
- Built-In Low-Power RC Oscillator
- Oscillator Frequency Range DC to 100kHz
- External Clock (Applied to Pin 3) can be Used Instead of Oscillator
- Operates as 2^N Frequency Divider or as a Single-Transition Timer
- Q/ \bar{Q} Select Provides Output Logic Level Flexibility
- AUTO or MASTER RESET Disables Oscillator During Reset to Reduce Power Dissipation
- Operates With Very Slow Clock Rise and Fall Times
- Capable of Driving Six Low Power TTL Loads, Three Low-Power Schottky Loads, or Six HTL Loads Over the Rated Temperature Range
- Symmetrical Output Characteristics
- 100% Tested for Quiescent Current at 20V
- 5V, 10V, and 15V Parametric Ratings
- Meets All Requirements of JEDEC Standard No. 13B, “Standard Specifications for Description of ‘B’ Series CMOS Devices”

Description

CD4541B programmable timer consists of a 16-stage binary counter, an oscillator that is controlled by external R-C components (2 resistors and a capacitor), an automatic power-on reset circuit, and output control logic. The counter increments on positive-edge clock transitions and can also be reset via the MASTER RESET input.

Pinout

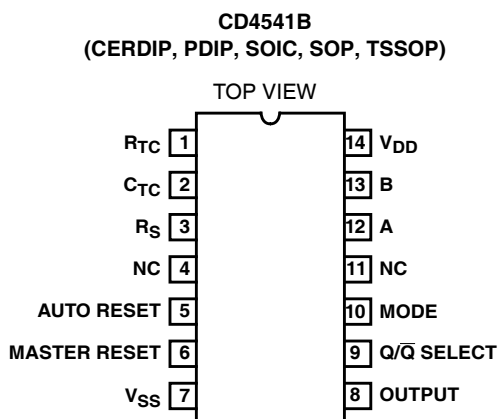

The output from this timer is the Q or \bar{Q} output from the 8th, 10th, 13th, or 16th counter stage. The desired stage is chosen using time-select inputs A and B (see Frequency Select Table).

The output is available in either of two modes selectable via the MODE input, pin 10 (see Truth Table). When this MODE input is a logic “1”, the output will be a continuous square wave having a frequency equal to the oscillator frequency divided by 2^N. With the MODE input set to logic “0” and after a MASTER RESET is initiated, the output (assuming Q output has been selected) changes from a low to a high state after 2^{N-1} counts and remains in that state until another MASTER RESET pulse is applied or the MODE input is set to a logic “1”.

Timing is initialized by setting the AUTO RESET input (pin 5) to logic “0” and turning power on. If pin 5 is set to logic “1”, the AUTO RESET circuit is disabled and counting will not start until after a positive MASTER RESET pulse is applied and returns to a low level. The AUTO RESET consumes an appreciable amount of power and should not be used if low-power operation is desired. For reliable automatic power-on reset, V_{DD} should be greater than 5V.

The RC oscillator, shown in Figure 2, oscillates with a frequency determined by the RC network and is calculated using:

$$f = \frac{1}{2.3 R_{TC} C_{TC}}$$

Where f is between 1kHz and 100kHz and R_S ≥ 10kΩ and ≈ 2R_{TC}

Ordering Information

PART NUMBER	TEMP. RANGE (°C)	PACKAGE
CD4541BF3A	-55 to 125	14 Ld CERDIP
CD4541BE	-55 to 125	14 Ld PDIP
CD4541BM	-55 to 125	14 Ld SOIC
CD4541BMT	-55 to 125	14 Ld SOIC
CD4541BM96	-55 to 125	14 Ld SOIC
CD4541BNSR	-55 to 125	14 Ld SOP
CD4541BPW	-55 to 125	14 Ld TSSOP
CD4541BPWR	-55 to 125	14 Ld TSSOP

NOTE: When ordering, use the entire part number. The suffixes 96 and R denote tape and reel. The suffix T denotes a small-quantity reel of 250.

CD4541B

Functional Diagram

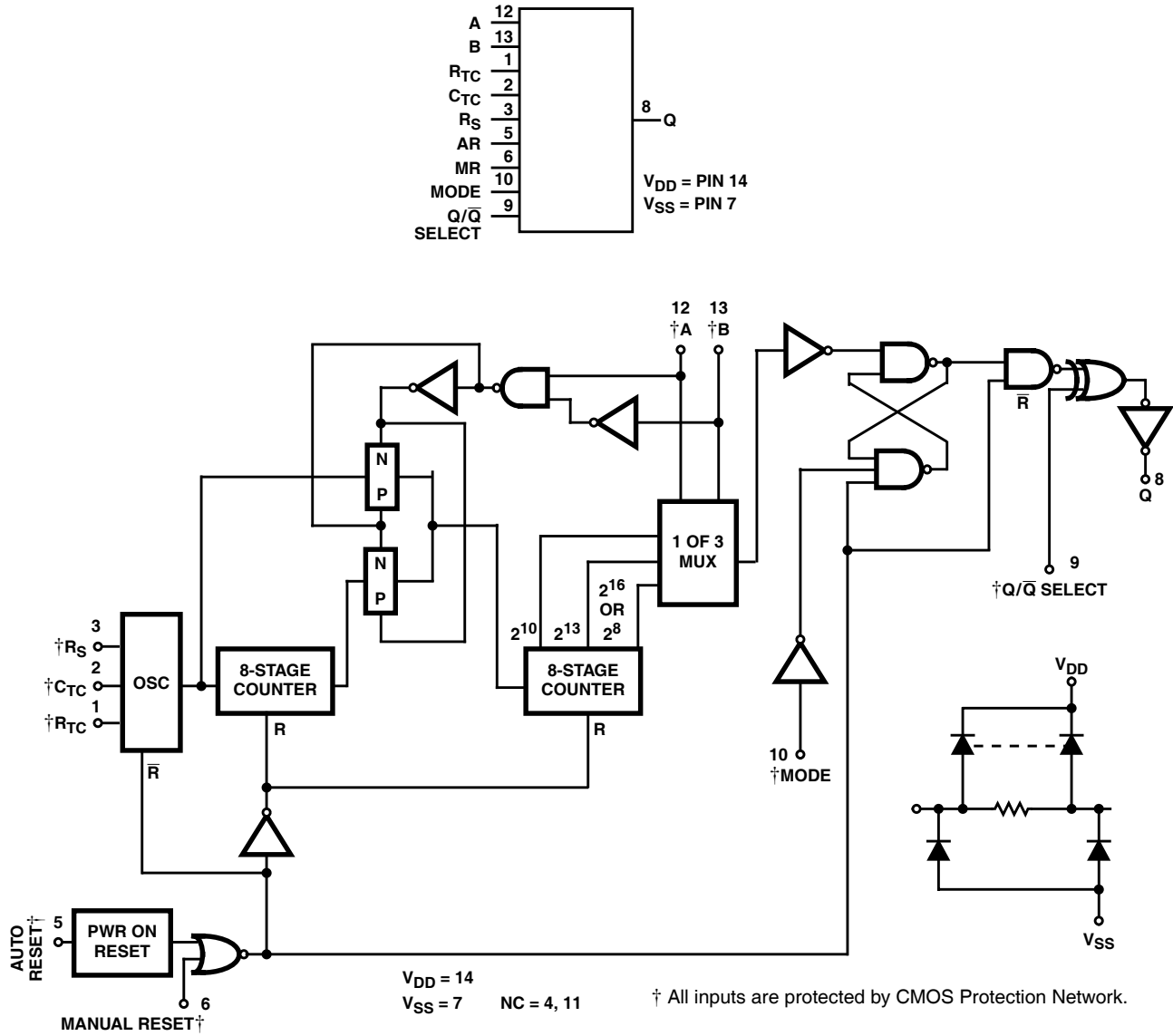

FIGURE 1.

FREQUENCY SELECTION TABLE

A	B	NO. OF STAGES N	COUNT 2 ^N
0	0	13	8192
0	1	10	1024
1	0	8	256
1	1	16	65536

TRUTH TABLE

PIN	STATE	
	0	1
5	Auto Reset On	Auto Reset Disable
6	Master Reset Off	Master Reset On
9	Output Initially Low After Reset (Q)	Output Initially High After Reset (\bar{Q})
10	Single Transition Mode	Recycle Mode

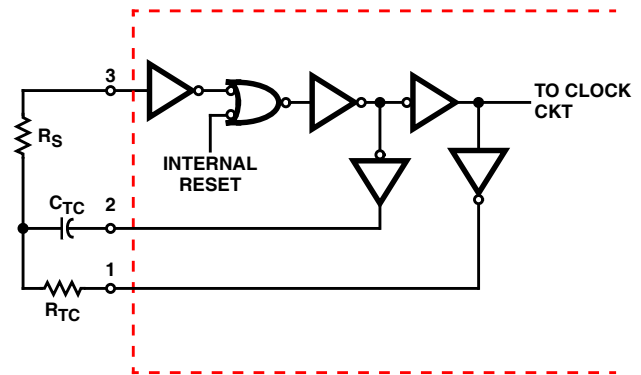

FIGURE 2. RC OSCILLATOR CIRCUIT

CD4541B

Absolute Maximum Ratings

DC Supply - Voltage Range, V_{DD}
 Voltages Referenced to V_{SS} Terminal -0.5V to +20V
 Input Voltage Range, All Inputs -0.5V to $V_{DD} + 0.5V$
 DC Input Current, Any One Input $\pm 10mA$
 Device Dissipation Per Output Transistor
 For T_A = Full Package Temperature Range
 (All Package Types) 100mW

Operating Conditions

Temperature Range T_A -55°C to 125°C
 Supply Voltage Range
 For T_A = Full Package Temperature Range 3V (Min), 18V (Typ)

Thermal Information

Package Thermal Impedance, θ_{JA} (see Note 1)
 PDIP package 80°C/W
 SOIC package 86°C/W
 SOP package 76°C/W
 TSSOP package 113°C/W
 Maximum Junction Temperature (Plastic Package) 150°C
 Maximum Storage Temperature Range (T_{STG}) -65°C to 150°C
 Maximum Lead Temperature (Soldering 10s)
 At Distance 1/16in \pm 1/32in (1.59mm \pm 0.79mm)
 from case for 10s Maximum 265°C
 (SOIC - Lead Tips Only)

CAUTION: Stresses above those listed in "Absolute Maximum Ratings" may cause permanent damage to the device. This is a stress only rating and operation of the device at these or any other conditions above those indicated in the operational sections of this specification is not implied.

NOTE:

- The package thermal impedance is calculated in accordance with JESD 51-7.

Electrical Specifications

PARAMETER	CONDITIONS			LIMITS AT INDICATED TEMPERATURES (°C)							UNITS
	V_O (V)	V_{IN} (V)	V_{DD} (V)	-55	-40	85	125	25			
								MIN	TYP	MAX	
Quiescent Device Current, (Note 2) I_{DD} (Max)	-	0, 5	5	5	5	150	150	-	0.04	5	μA
	-	0, 10	10	10	10	300	300	-	0.04	10	μA
	-	0, 15	15	20	20	600	600	-	0.04	20	μA
	-	0, 20	20	100	100	3000	3000	-	0.08	100	μA
Output Low (Sink) Current I_{OL} (Min)	0.4	0, 5	5	1.9	1.85	1.26	1.08	1.55	3.1	-	mA
	0.5	0, 10	10	5	4.8	3.3	2.8	4	8	-	mA
	1.5	0, 15	15	12.6	12	8.4	7.2	10	20	-	mA
Output High (Source) Current, I_{OH} (Min)	4.6	0, 5	5	-1.9	-1.85	-1.26	-1.08	-1.55	-3.1	-	mA
	2.5	0, 5	5	-6.2	-6	-4.1	-3	-5	-10	-	mA
	9.5	0, 10	10	-5	-4.8	-3.3	-2.8	-4	-8	-	mA
	13.5	0, 15	15	-12.6	-12	-8.4	-7.2	-10	-20	-	mA
Output Voltage: Low-Level, V_{OL} (Max)	-	0, 5	5	-	-	0.05	-	-	0	0.05	V
	-	0, 10	10	-	-	0.05	-	-	0	0.05	V
	-	0, 15	15	-	-	0.05	-	-	0	0.05	V
Output Voltage: High-Level, V_{OH} (Min)	-	0, 5	5	-	-	4.95	-	4.95	5	-	V
	-	0, 10	10	-	-	9.95	-	9.95	10	-	V
	-	0, 15	15	-	-	14.95	-	14.95	15	-	V
Input Low Voltage, V_{IL} (Max)	0.5, 4.5	-	5	-	-	1.5	-	-	-	1.5	V
	1, 9	-	10	-	-	3	-	-	-	3	V
	1.5, 13.5	-	15	-	-	4	-	-	-	4	V

CD4541B

Electrical Specifications (Continued)

PARAMETER	CONDITIONS			LIMITS AT INDICATED TEMPERATURES (°C)							UNITS
	V _O (V)	V _{IN} (V)	V _{DD} (V)	-55	-40	85	125	25			
								MIN	TYP	MAX	
Input High Voltage, V _{IH} (Min)	0.5, 4.5	-	5	-		3.5		3.5	-	-	V
	1, 9	-	10	-		7		7	-	-	V
	1.5, 13.5	-	15	-		11		11	-	-	V
Input Current, I _{IN} (Max)	-	0, 18	18	±0.1	±0.1	±1	±1	-	±10 ⁻⁵	±0.1	µA

NOTE:

2. With AUTO RESET enabled, additional current drain at 25°C is:
 7µA (Typ), 200µA (Max) at 5V;
 30µA (Typ), 350µA (Max) at 10V;
 80µA (Typ), 500µA (Max) at 15V

Dynamic Electrical Specifications $T_A = 25^\circ\text{C}$, Input $t_r, t_f = 20\text{ns}$, $C_L = 50\text{pF}$, $R_L = 200\text{k}\Omega$

PARAMETER	SYMBOL	V _{DD} (V)	MIN	TYP	MAX	UNITS
Propagation Delay Times Clock to Q	(2 ⁸) t _{PHL} , t _{PLH}	5	-	3.5	10.5	µs
		10	-	1.25	3.8	µs
		15	-	0.9	2.9	µs
	(2 ¹⁶) t _{PHL} , t _{PLH}	5	-	6.0	18	µs
		10	-	3.5	10	µs
		15	-	2.5	7.5	µs
Transition Time	t _{THL}	5	-	100	200	ns
		10	-	50	100	ns
		15	-	40	80	ns
	t _{THL}	5	-	180	360	ns
		10	-	90	180	ns
		15	-	65	130	ns
MASTER RESET, CLOCK Pulse Width		5	900	300	-	ns
		10	300	100	-	ns
		15	225	85	-	ns
Maximum Clock Pulse Input Frequency	f _{CL}	5	-	1.5	-	MHz
		10	-	4	-	MHz
		15	-	6	-	MHz
Maximum Clock Pulse Input Rise or Fall time	t _r , t _f	5, 10, 15	Unlimited			µs

Digital Timer Application

A positive pulse on MASTER RESET resets the counters and latch. The output goes high and remains high until the number of pulses, selected by A and B, are counted. This circuit is retriggerable and is as accurate as the input frequency. If additional accuracy is desired, an external clock can be used on pin 3. A setup time equal to the width of the one-shot output is required immediately following initial power up, during which time the output will be high.

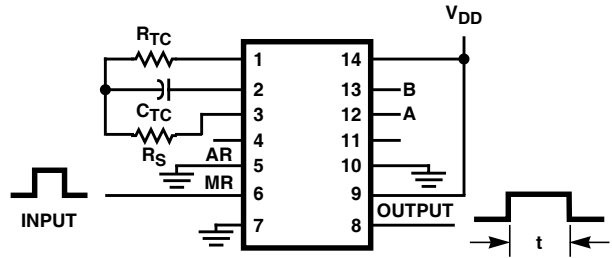

FIGURE 3. DIGITAL TIMER APPLICATION CIRCUIT

PACKAGING INFORMATION

Orderable Device	Status (1)	Package Type	Package Drawing	Pins	Package Qty	Eco Plan (2)	Lead finish/ Ball material (6)	MSL Peak Temp (3)	Op Temp (°C)	Device Marking (4/5)	Samples
CD4541BE	ACTIVE	PDIP	N	14	25	RoHS & Green	NIPDAU SN	N / A for Pkg Type	-55 to 125	CD4541BE	Samples
CD4541BEE4	ACTIVE	PDIP	N	14	25	RoHS & Green	NIPDAU	N / A for Pkg Type	-55 to 125	CD4541BE	Samples
CD4541BF	ACTIVE	CDIP	J	14	25	Non-RoHS & Green	SNPB	N / A for Pkg Type	-55 to 125	CD4541BF	Samples
CD4541BF3A	ACTIVE	CDIP	J	14	25	Non-RoHS & Green	SNPB	N / A for Pkg Type	-55 to 125	CD4541BF3A	Samples
CD4541BM	ACTIVE	SOIC	D	14	50	RoHS & Green	NIPDAU	Level-1-260C-UNLIM	-55 to 125	CD4541BM	Samples
CD4541BM96	ACTIVE	SOIC	D	14	2500	RoHS & Green	NIPDAU SN	Level-1-260C-UNLIM	-55 to 125	CD4541BM	Samples
CD4541BMT	ACTIVE	SOIC	D	14	250	RoHS & Green	NIPDAU	Level-1-260C-UNLIM	-55 to 125	CD4541BM	Samples
CD4541BMTG4	ACTIVE	SOIC	D	14	250	RoHS & Green	NIPDAU	Level-1-260C-UNLIM	-55 to 125	CD4541BM	Samples
CD4541BNSR	ACTIVE	SO	NS	14	2000	RoHS & Green	NIPDAU	Level-1-260C-UNLIM	-55 to 125	CD4541B	Samples
CD4541BPW	ACTIVE	TSSOP	PW	14	90	RoHS & Green	NIPDAU	Level-1-260C-UNLIM	-55 to 125	CM541B	Samples
CD4541BPWR	ACTIVE	TSSOP	PW	14	2000	RoHS & Green	NIPDAU SN	Level-1-260C-UNLIM	-55 to 125	CM541B	Samples

(1) The marketing status values are defined as follows:

ACTIVE: Product device recommended for new designs.

LIFEBUY: TI has announced that the device will be discontinued, and a lifetime-buy period is in effect.

NRND: Not recommended for new designs. Device is in production to support existing customers, but TI does not recommend using this part in a new design.

PREVIEW: Device has been announced but is not in production. Samples may or may not be available.

OBSELETE: TI has discontinued the production of the device.

(2) **RoHS:** TI defines "RoHS" to mean semiconductor products that are compliant with the current EU RoHS requirements for all 10 RoHS substances, including the requirement that RoHS substance do not exceed 0.1% by weight in homogeneous materials. Where designed to be soldered at high temperatures, "RoHS" products are suitable for use in specified lead-free processes. TI may reference these types of products as "Pb-Free".

RoHS Exempt: TI defines "RoHS Exempt" to mean products that contain lead but are compliant with EU RoHS pursuant to a specific EU RoHS exemption.

Green: TI defines "Green" to mean the content of Chlorine (Cl) and Bromine (Br) based flame retardants meet JS709B low halogen requirements of <=1000ppm threshold. Antimony trioxide based flame retardants must also meet the <=1000ppm threshold requirement.

(3) MSL, Peak Temp. - The Moisture Sensitivity Level rating according to the JEDEC industry standard classifications, and peak solder temperature.

(4) There may be additional marking, which relates to the logo, the lot trace code information, or the environmental category on the device.

(5) Multiple Device Markings will be inside parentheses. Only one Device Marking contained in parentheses and separated by a "~" will appear on a device. If a line is indented then it is a continuation of the previous line and the two combined represent the entire Device Marking for that device.

(6) Lead finish/Ball material - Orderable Devices may have multiple material finish options. Finish options are separated by a vertical ruled line. Lead finish/Ball material values may wrap to two lines if the finish value exceeds the maximum column width.

Important Information and Disclaimer:The information provided on this page represents TI's knowledge and belief as of the date that it is provided. TI bases its knowledge and belief on information provided by third parties, and makes no representation or warranty as to the accuracy of such information. Efforts are underway to better integrate information from third parties. TI has taken and continues to take reasonable steps to provide representative and accurate information but may not have conducted destructive testing or chemical analysis on incoming materials and chemicals. TI and TI suppliers consider certain information to be proprietary, and thus CAS numbers and other limited information may not be available for release.

In no event shall TI's liability arising out of such information exceed the total purchase price of the TI part(s) at issue in this document sold by TI to Customer on an annual basis.

OTHER QUALIFIED VERSIONS OF CD4541B, CD4541B-MIL :

- Catalog : [CD4541B](#)
- Military : [CD4541B-MIL](#)

NOTE: Qualified Version Definitions:

- Catalog - TI's standard catalog product
- Military - QML certified for Military and Defense Applications

TAPE AND REEL INFORMATION

QUADRANT ASSIGNMENTS FOR PIN 1 ORIENTATION IN TAPE

*All dimensions are nominal

Device	Package Type	Package Drawing	Pins	SPQ	Reel Diameter (mm)	Reel Width W1 (mm)	A0 (mm)	B0 (mm)	K0 (mm)	P1 (mm)	W (mm)	Pin1 Quadrant
CD4541BM96	SOIC	D	14	2500	330.0	16.4	6.5	9.0	2.1	8.0	16.0	Q1
CD4541BMT	SOIC	D	14	250	330.0	16.4	6.5	9.0	2.1	8.0	16.0	Q1
CD4541BNSR	SO	NS	14	2000	330.0	16.4	8.2	10.5	2.5	12.0	16.0	Q1
CD4541BPWR	TSSOP	PW	14	2000	330.0	12.4	6.9	5.6	1.6	8.0	12.0	Q1

TAPE AND REEL BOX DIMENSIONS



*All dimensions are nominal

Device	Package Type	Package Drawing	Pins	SPQ	Length (mm)	Width (mm)	Height (mm)
CD4541BM96	SOIC	D	14	2500	356.0	356.0	35.0
CD4541BMT	SOIC	D	14	250	210.0	185.0	35.0
CD4541BNSR	SO	NS	14	2000	356.0	356.0	35.0
CD4541BPWR	TSSOP	PW	14	2000	356.0	356.0	35.0

TUBE

*All dimensions are nominal

Device	Package Name	Package Type	Pins	SPQ	L (mm)	W (mm)	T (μm)	B (mm)
CD4541BE	N	PDIP	14	25	506	13.97	11230	4.32
CD4541BE	N	PDIP	14	25	506.1	9	600	5.4
CD4541BE	N	PDIP	14	25	506	13.97	11230	4.32
CD4541BEE4	N	PDIP	14	25	506	13.97	11230	4.32
CD4541BEE4	N	PDIP	14	25	506.1	9	600	5.4
CD4541BEE4	N	PDIP	14	25	506	13.97	11230	4.32
CD4541BM	D	SOIC	14	50	506.6	8	3940	4.32
CD4541BPW	PW	TSSOP	14	90	530	10.2	3600	3.5

MECHANICAL DATA

NS (R-PDSO-G**)

PLASTIC SMALL-OUTLINE PACKAGE

14-PINS SHOWN



- NOTES:
- A. All linear dimensions are in millimeters.
 - B. This drawing is subject to change without notice.
 - C. Body dimensions do not include mold flash or protrusion, not to exceed 0,15.

J 14

GENERIC PACKAGE VIEW
CDIP - 5.08 mm max height
CERAMIC DUAL IN LINE PACKAGE



Images above are just a representation of the package family, actual package may vary.
Refer to the product data sheet for package details.

4040083-5/G

J0014A



PACKAGE OUTLINE

CDIP - 5.08 mm max height

CERAMIC DUAL IN LINE PACKAGE



4214771/A 05/2017

NOTES:

1. All controlling linear dimensions are in inches. Dimensions in brackets are in millimeters. Any dimension in brackets or parenthesis are for reference only. Dimensioning and tolerancing per ASME Y14.5M.
2. This drawing is subject to change without notice.
3. This package is hermetically sealed with a ceramic lid using glass frit.
4. Index point is provided on cap for terminal identification only and on press ceramic glass frit seal only.
5. Falls within MIL-STD-1835 and GDIP1-T14.

EXAMPLE BOARD LAYOUT

J0014A

CDIP - 5.08 mm max height

CERAMIC DUAL IN LINE PACKAGE



LAND PATTERN EXAMPLE
NON-SOLDER MASK DEFINED
SCALE: 5X

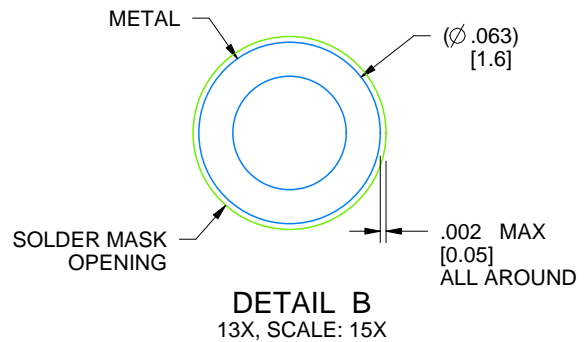
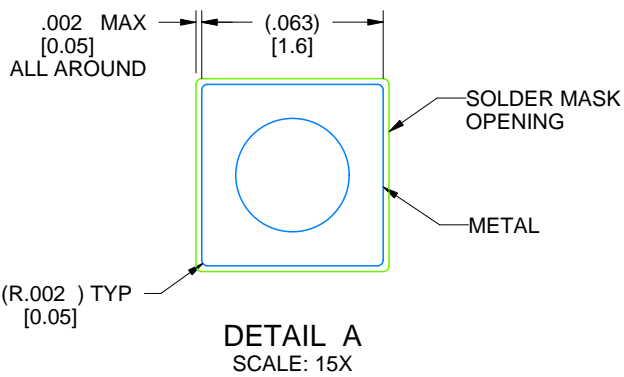

4214771/A 05/2017

D (R-PDSO-G14)

PLASTIC SMALL OUTLINE



- NOTES:
- A. All linear dimensions are in inches (millimeters).
 - B. This drawing is subject to change without notice.
 -  Body length does not include mold flash, protrusions, or gate burrs. Mold flash, protrusions, or gate burrs shall not exceed 0.006 (0,15) each side.
 -  Body width does not include interlead flash. Interlead flash shall not exceed 0.017 (0,43) each side.
 - E. Reference JEDEC MS-012 variation AB.

D (R-PDSO-G14)

PLASTIC SMALL OUTLINE



4211283-3/E 08/12

- NOTES:
- All linear dimensions are in millimeters.
 - This drawing is subject to change without notice.
 - Publication IPC-7351 is recommended for alternate designs.
 - Laser cutting apertures with trapezoidal walls and also rounding corners will offer better paste release. Customers should contact their board assembly site for stencil design recommendations. Refer to IPC-7525 for other stencil recommendations.
 - Customers should contact their board fabrication site for solder mask tolerances between and around signal pads.

PW (R-PDSO-G14)

PLASTIC SMALL OUTLINE



4040064-3/G 02/11

- NOTES:
- A. All linear dimensions are in millimeters. Dimensioning and tolerancing per ASME Y14.5M-1994.
 - B. This drawing is subject to change without notice.
 - C. Body length does not include mold flash, protrusions, or gate burrs. Mold flash, protrusions, or gate burrs shall not exceed 0,15 each side.
 - D. Body width does not include interlead flash. Interlead flash shall not exceed 0,25 each side.
 - E. Falls within JEDEC MO-153

PW (R-PDSO-G14)

PLASTIC SMALL OUTLINE

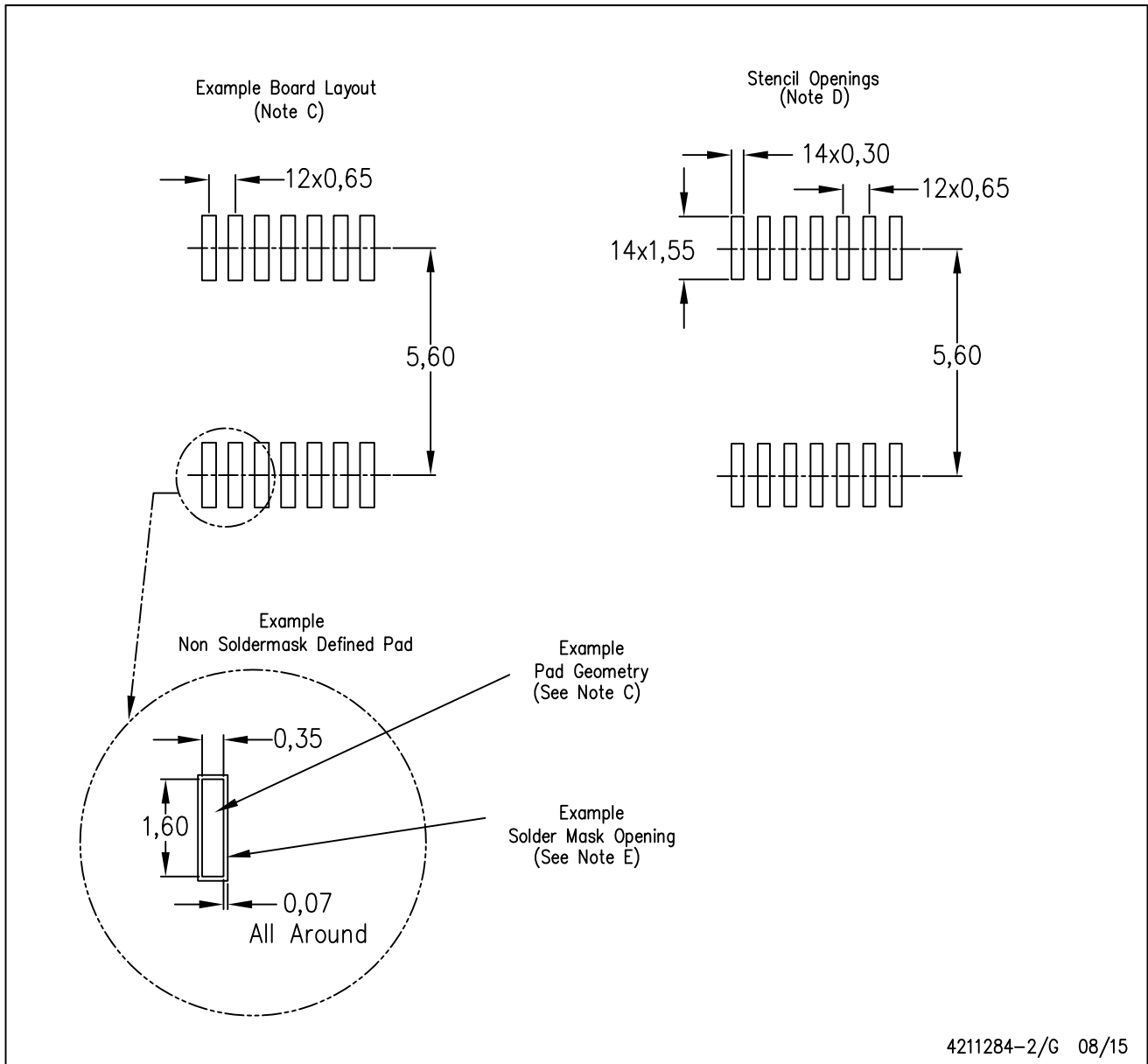

4211284-2/G 08/15

- NOTES:
- A. All linear dimensions are in millimeters.
 - B. This drawing is subject to change without notice.
 - C. Publication IPC-7351 is recommended for alternate designs.
 - D. Laser cutting apertures with trapezoidal walls and also rounding corners will offer better paste release. Customers should contact their board assembly site for stencil design recommendations. Refer to IPC-7525 for other stencil recommendations.
 - E. Customers should contact their board fabrication site for solder mask tolerances between and around signal pads.

N (R-PDIP-T**)

PLASTIC DUAL-IN-LINE PACKAGE

16 PINS SHOWN



- NOTES:
- A. All linear dimensions are in inches (millimeters).
 - B. This drawing is subject to change without notice.
 - C Falls within JEDEC MS-001, except 18 and 20 pin minimum body length (Dim A).
 - D The 20 pin end lead shoulder width is a vendor option, either half or full width.

4040049/E 12/2002

IMPORTANT NOTICE AND DISCLAIMER

TI PROVIDES TECHNICAL AND RELIABILITY DATA (INCLUDING DATA SHEETS), DESIGN RESOURCES (INCLUDING REFERENCE DESIGNS), APPLICATION OR OTHER DESIGN ADVICE, WEB TOOLS, SAFETY INFORMATION, AND OTHER RESOURCES "AS IS" AND WITH ALL FAULTS, AND DISCLAIMS ALL WARRANTIES, EXPRESS AND IMPLIED, INCLUDING WITHOUT LIMITATION ANY IMPLIED WARRANTIES OF MERCHANTABILITY, FITNESS FOR A PARTICULAR PURPOSE OR NON-INFRINGEMENT OF THIRD PARTY INTELLECTUAL PROPERTY RIGHTS.

These resources are intended for skilled developers designing with TI products. You are solely responsible for (1) selecting the appropriate TI products for your application, (2) designing, validating and testing your application, and (3) ensuring your application meets applicable standards, and any other safety, security, regulatory or other requirements.

These resources are subject to change without notice. TI grants you permission to use these resources only for development of an application that uses the TI products described in the resource. Other reproduction and display of these resources is prohibited. No license is granted to any other TI intellectual property right or to any third party intellectual property right. TI disclaims responsibility for, and you will fully indemnify TI and its representatives against, any claims, damages, costs, losses, and liabilities arising out of your use of these resources.

TI's products are provided subject to [TI's Terms of Sale](#) or other applicable terms available either on [ti.com](https://www.ti.com) or provided in conjunction with such TI products. TI's provision of these resources does not expand or otherwise alter TI's applicable warranties or warranty disclaimers for TI products.

TI objects to and rejects any additional or different terms you may have proposed.

Mailing Address: Texas Instruments, Post Office Box 655303, Dallas, Texas 75265
Copyright © 2024, Texas Instruments Incorporated

Looking for pricing, stock, or lifecycle information?

Click below to explore more details on WIN SOURCE:

 [View CD4541BM96](#) on WIN SOURCE

 [Texas Instruments](#) Information

Optimize Your Supply Chain with WIN SOURCE Solutions

-  Global Sourcing Solution
-  Obsolete Management
-  Cost Control Management
-  Shortage Management
-  Alternative Solution
-  Excess Inventory Management