



**THE DATASHEET OF
MAX2685EEE+**



Low-Cost, 900MHz, Low-Noise Amplifier and Downconverter Mixer

General Description

The MAX2685's low-noise amplifier (LNA) and down-converter mixer comprise the major blocks of an RF front-end receiver. Optimized for 900MHz operation, the device's low noise figure, high gain, and high linearity make it ideal for cellular, cordless, and wireless data applications. A low supply current of 8.5mA (high-gain mode) and 3.8mA (low-gain mode) plus a low operating supply voltage range of +2.7V to +5.5V make it suitable for use in 3-cell NiCd or 1-cell lithium-ion (Li+) battery applications. A low-power shutdown mode further extends battery life by reducing supply current below 0.1 μ A.

The MAX2685 includes an LNA, LNA bypass switch, downconverter mixer, and local-oscillator (LO) buffer. The LNA has a low noise figure of 1.4dB, a high gain of 15dB, and an input third-order intercept point (IP3) of -4dBm. The mixer has a noise figure of 13dB, a gain of 6dB, and an input IP3 of +7dBm. In addition, an LNA bypass switch allows two levels of gain, reducing power consumption when high gain is not needed.

The downconverter mixer has a single-ended RF input port and differential IF output ports. Differential operation of the IF ports offers improved even-order harmonic rejection and increased immunity to noise. An LO buffer allows the LO port to be driven with only -8dBm of LO power. The MAX2685 is offered in a space-saving 16-pin QSOP package.

Applications

Cellular/Cordless Phones 900MHz ISM-Band Radios
Wireless Data 868MHz European ISM Band

Pin Configuration

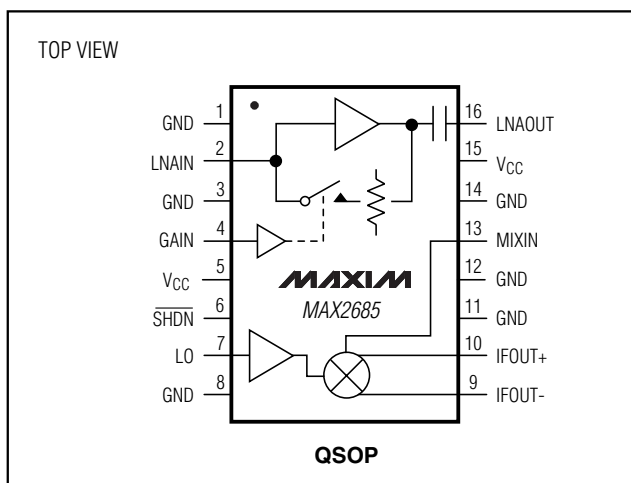

Features

- ◆ 800MHz to 1000MHz RF Frequency Range
- ◆ +2.7V to +5.5V Single-Supply Operation
- ◆ Integrated LNA + Mixer + LO Buffer
- ◆ Logic-Controlled LNA Bypass Switch Reduces Supply Current
- ◆ LNA Performance (High/Low Gain)
 - Gain: +15dB/-12dB
 - NF: 1.4dB/12dB
 - Input IP3: -4dBm/+16dBm
- ◆ Mixer Performance (High/Low Gain)
 - Gain: 6dB/4.6dB
 - NF: 13dB/12dB
 - Input IP3: +7dBm/-1.5dBm
- ◆ Supply Current
 - 8.5mA (High Gain)
 - 3.8mA (Low Gain)
- ◆ <0.1 μ A Supply Current in Shutdown Mode
- ◆ 0.8 μ s Receiver Enable Time

Ordering Information

PART	TEMP. RANGE	PIN-PACKAGE
MAX2685EEE	-40°C to +85°C	16 QSOP

Functional Diagram

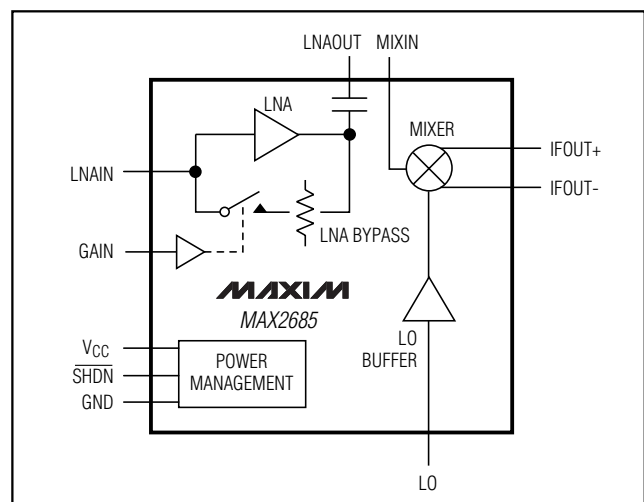

Low-Cost, 900MHz, Low-Noise Amplifier and Downconverter Mixer

ABSOLUTE MAXIMUM RATINGS

V _{CC} to GND	-0.3V to +6V	Continuous Power Dissipation (T _A = +70°C)
LNAIN Input Power (50Ω source)	+10dBm	16-Pin QSOP (derate 8.3mW/°C above +70°C).....
LO Input Power (50Ω source)	+10dBm	667mW
MIXIN Input Power (50Ω source)	+10dBm	Junction Temperature
IFOUT+, IFOUT- to GND	-0.3V to +6V	+150°C
LNAOUT to GND	-0.3V to +6V	Operating Temperature Range
GAIN, SHDN to GND	-0.3V to (V _{CC} + 0.3V)	-40°C to +85°C
		Storage Temperature Range
		-65°C to +150°C
		Lead Temperature (soldering, 10s)
		+300°C

Stresses beyond those listed under "Absolute Maximum Ratings" may cause permanent damage to the device. These are stress ratings only, and functional operation of the device at these or any other conditions beyond those indicated in the operational sections of the specifications is not implied. Exposure to absolute maximum rating conditions for extended periods may affect device reliability.

DC ELECTRICAL CHARACTERISTICS

(V_{CC} = +2.7V to +5.5V, V_{SHDN} = +2V, V_{GAIN} = +2V, LNAIN = LNAOUT = MIXIN = LO = unconnected, IFOUT+ = IFOUT- = V_{CC}, T_A = -40°C to +85°C. Typical values are at T_A = +25°C and V_{CC} = +3V, unless otherwise noted.)

PARAMETER	CONDITIONS	MIN	TYP	MAX	UNITS
Supply Voltage Range		2.7		5.5	V
Operating Supply Current	GAIN = V _{CC} (Note 1)		8.5	14.1	mA
	GAIN = GND (Note 1)		3.8	6.4	
Shutdown Supply Current	SHDN = GND (Note 1)		0.1	1.0	μA
Logic Input Voltage High	GAIN, SHDN	2.0			V
Logic Input Voltage Low	GAIN, SHDN			0.5	V
Logic Input Current	V _{SHDN} = V _{GAIN} = 0 to 5.5V (Note 1)		±0.01	±1	μA

AC ELECTRICAL CHARACTERISTICS

(MAX2685 EV kit, V_{CC} = V_{SHDN} = +3V, f_{LNAIN} = f_{MIXIN} = 880MHz, f_{LO} = 960MHz, P_{LNAIN} = -30dBm, P_{LO} = -8dBm, P_{MIXIN} = -25dBm, differential IFOUT operation, Z_o = 50Ω, T_A = +25°C, unless otherwise noted.)

PARAMETER	CONDITIONS	MIN	TYP	MAX	UNITS
LOW-NOISE AMPLIFIER (LNA)					
RF Frequency Range (Note 2)		800		1000	MHz
LNA Gain	GAIN = V _{CC} (Note 1)	13	15	16.2	dB
	GAIN = GND (Note 1)	-14	-12	-10.3	
LNA Gain Variation over Temperature	GAIN = V _{CC} , T _A = T _{MIN} to T _{MAX} (Note 3)		0.9	1.6	dB
LNA Noise Figure	GAIN = V _{CC}		1.4		dB
	GAIN = GND		12.2		
LNA Input IP3	GAIN = V _{CC} (Note 4)		-4.1		dBm
	GAIN = GND (Note 5)		+16.2		
LNA Input 1dB Compression	GAIN = V _{CC}		-18.4		dBm
LNAOUT Port Return Loss	GAIN = V _{CC}		-18.6		dB
	GAIN = GND		-11.3		
DOWNCONVERTER MIXER					
RF Frequency Range (Note 2)		800		1000	MHz
Mixer Conversion Gain	GAIN = V _{CC} (Note 1)	4.7	6.1	7.0	dB
	GAIN = GND (Note 1)	2.5	4.6	6.0	

Low-Cost, 900MHz, Low-Noise Amplifier and Downconverter Mixer

AC ELECTRICAL CHARACTERISTICS (continued)

(MAX2685 EV kit, $V_{CC} = \overline{SHDN} = +3V$, $f_{LNAIN} = f_{MIXIN} = 880MHz$, $f_{LO} = 960MHz$, $P_{LNAIN} = -30dBm$, $P_{LO} = -8dBm$, $P_{MIXIN} = -25dBm$, differential IFOUT operation, $Z_o = 50\Omega$, $T_A = +25^\circ C$, unless otherwise noted.)

PARAMETER	CONDITIONS	MIN	TYP	MAX	UNITS
Mixer Conversion Gain Variation over Temperature	GAIN = V_{CC} , $T_A = T_{MIN}$ to T_{MAX} (Note 3)		1	2	dB
Mixer Noise Figure (SSB)	GAIN = V_{CC}		13		dB
	GAIN = GND		12.1		
Mixer Input IP3 (Note 6)	GAIN = V_{CC}		7		dBm
	GAIN = GND		-1.5		
LO Port Return Loss			11		dB
LO-to-LNAIN Isolation	$\overline{SHDN} = V_{CC}$ or GND		53		dB
LO-to-MIXIN Isolation			31		dB
LNAOUT-to-MIXIN Isolation			28		dB
OVERALL SYSTEM					
Receiver Enable Time	(Note 7)		0.8		μs

- Note 1:** Performance at temperatures greater than or equal to $+25^\circ C$ are guaranteed by production test; performance at temperatures less than $+25^\circ C$ are guaranteed by design and characterization.
- Note 2:** This is the recommended operating frequency range.
- Note 3:** Maximum and minimum limits are guaranteed by design and device characterization and are not production tested.
- Note 4:** Two tones at 880MHz and 880.1MHz, -30dBm per tone.
- Note 5:** Two tones at 880MHz and 880.1MHz, -10dBm per tone.
- Note 6:** Two tones at 880MHz and 880.1MHz, -25dBm per tone.
- Note 7:** Time from $\overline{SHDN} =$ high, until the cascaded receive gain is within 1dB of its final value. Measured with 47pF blocking capacitors on LNAIN and LNAOUT. Matching network removed from IFOUT output.

Typical Operating Characteristics

(MAX2685 EV kit, $V_{CC} = \overline{SHDN} = +3V$, $f_{LNAIN} = f_{MIXIN} = 880MHz$, $f_{LO} = 960MHz$, $P_{LNAIN} = -30dBm$, $P_{LO} = -8dBm$, $P_{MIXIN} = -25dBm$, differential IFOUT operation, $Z_o = 50\Omega$, $T_A = +25^\circ C$, unless otherwise noted.)

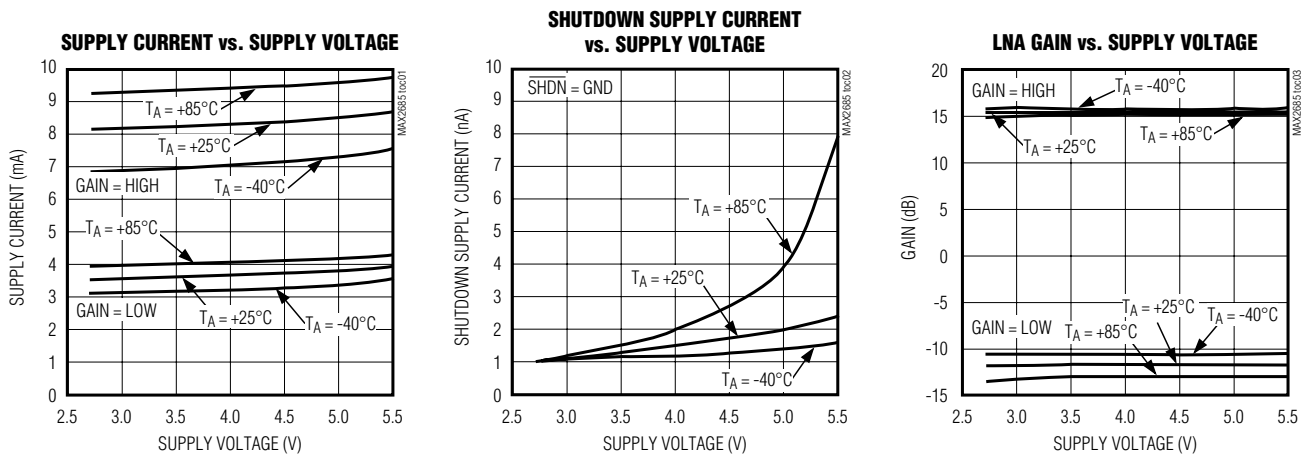

Low-Cost, 900MHz, Low-Noise Amplifier and Downconverter Mixer

Typical Operating Characteristics (continued)

(MAX2685 EV kit, $V_{CC} = V_{SHDN} = +3V$, $f_{LNAIN} = f_{MIXIN} = 880MHz$, $f_{LO} = 960MHz$, $P_{LNAIN} = -30dBm$, $P_{LO} = -8dBm$, $P_{MIXIN} = -25dBm$, differential IFOUT operation, $Z_0 = 50\Omega$, $T_A = +25^\circ C$, unless otherwise noted.)

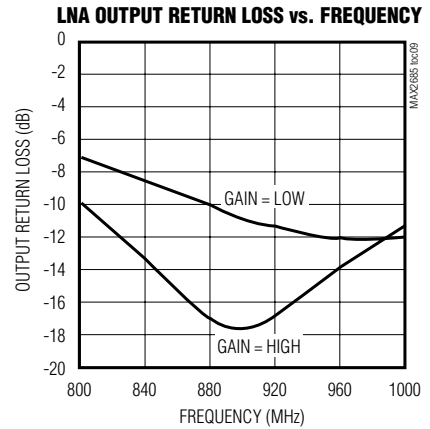
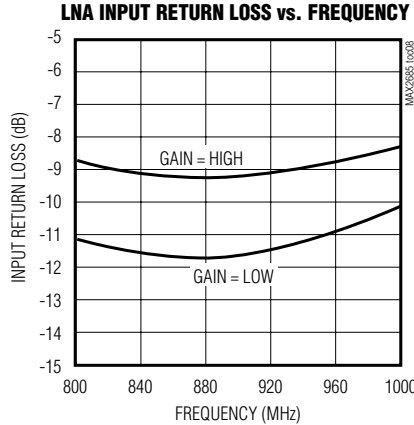
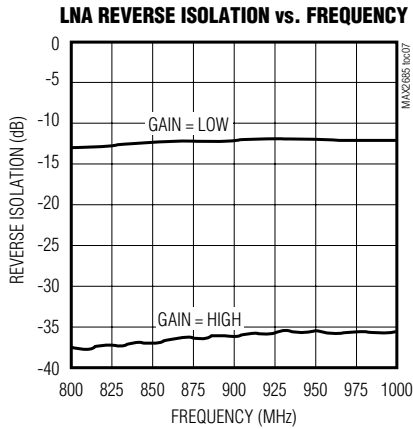
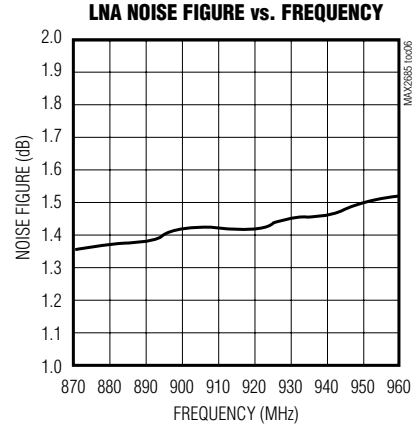
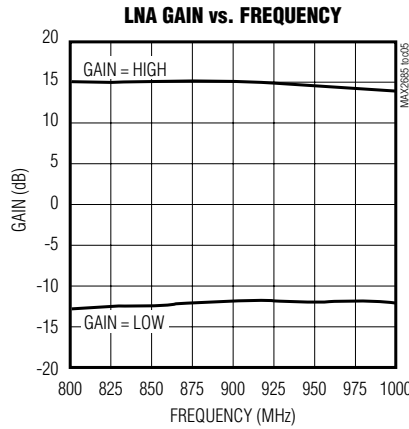
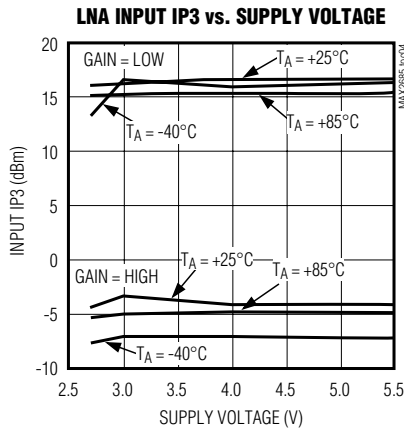

LNA S11 vs. FREQUENCY (800MHz to 1000MHz UNMATCHED)

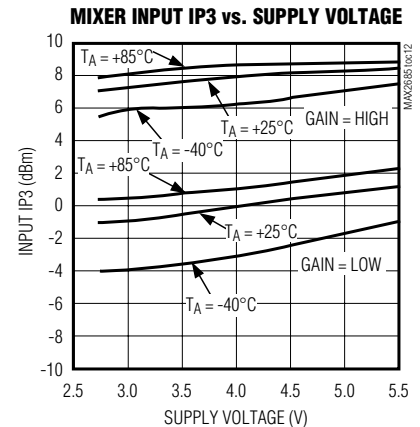
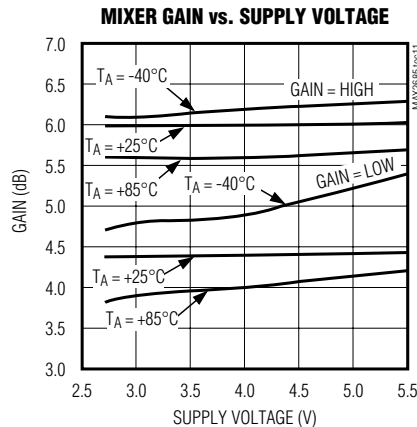
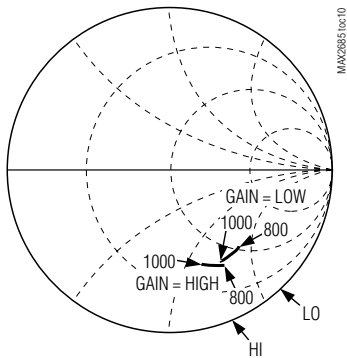

Low-Cost, 900MHz, Low-Noise Amplifier and Downconverter Mixer

MAX2685

Typical Operating Characteristics (continued)

(MAX2685 EV kit, $V_{CC} = V_{SHDN} = +3V$, $f_{LNAIN} = f_{MIXIN} = 880MHz$, $f_{LO} = 960MHz$, $P_{LNAIN} = -30dBm$, $P_{LO} = -8dBm$, $P_{MIXIN} = -25dBm$, differential IFOUT operation, $Z_0 = 50\Omega$, $T_A = +25^\circ C$, unless otherwise noted.)

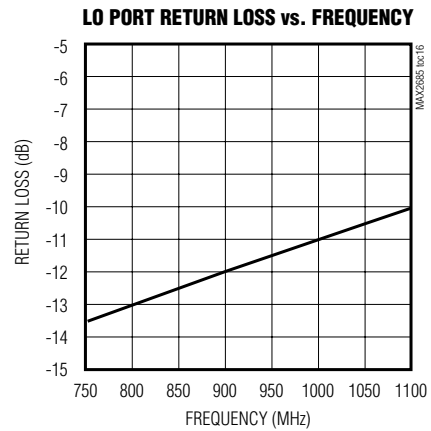
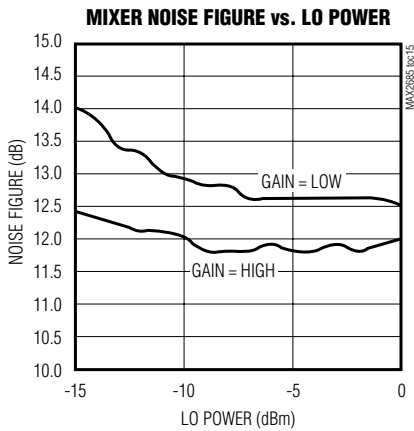
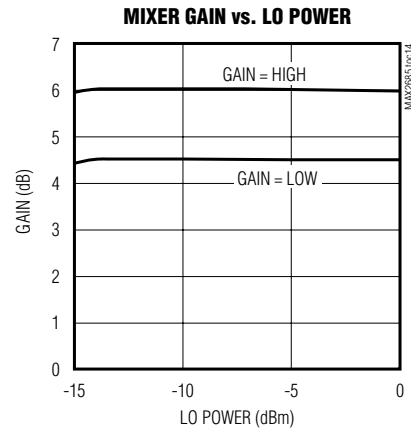
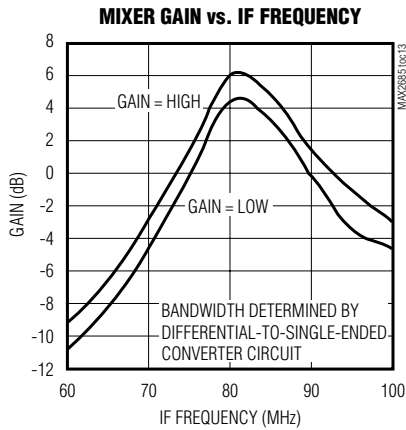

Low-Cost, 900MHz, Low-Noise Amplifier and Downconverter Mixer

Pin Description

PIN	NAME	FUNCTION
1, 3, 8, 11, 12, 14	GND	Ground. Connect to ground plane with a low-inductance connection.
2	LNAIN	RF Input to LNA and LNA Bypass Switch. Requires an external matching network and a series DC-blocking capacitor.
4	GAIN	Gain Control Logic-Level Input. Drive high to enable the LNA, open the LNA bypass switch, and increase the receiver's gain. Drive low to disable the LNA, close the LNA bypass switch, and reduce the receiver's gain.
5, 15	V _{CC}	Supply Voltage. Bypass V _{CC} to GND at each pin with a 47pF capacitor as close to the pin as possible.
6	$\overline{\text{SHDN}}$	Shutdown Control Logic-Level Input. Drive high or connect to V _{CC} for normal operation. Drive low to place the device in low-power shutdown mode.
7	LO	Local-Oscillator Input to Downconverter Mixer. Requires a series DC-blocking capacitor and an impedance-setting resistor (typically 75Ω to ground).
9	IFOUT-	Inverting Side to Downconverter Mixer's Differential Open-Collector IF Output. Requires a pull-up inductor to V _{CC} for proper biasing, as well as a matching network to ensure optimum output power.
10	IFOUT+	Noninverting Side of Downconverter Mixer's Differential Open-Collector IF Output. Requires a pull-up inductor to V _{CC} for proper biasing, as well as a matching network to ensure optimum output power.
13	MIXIN	RF Input to Downconverter Mixer. Requires an external matching network and series DC-blocking capacitor.
16	LNAOUT	LNA Output. Internally matched to 50Ω. LNAOUT has an internal blocking capacitor.

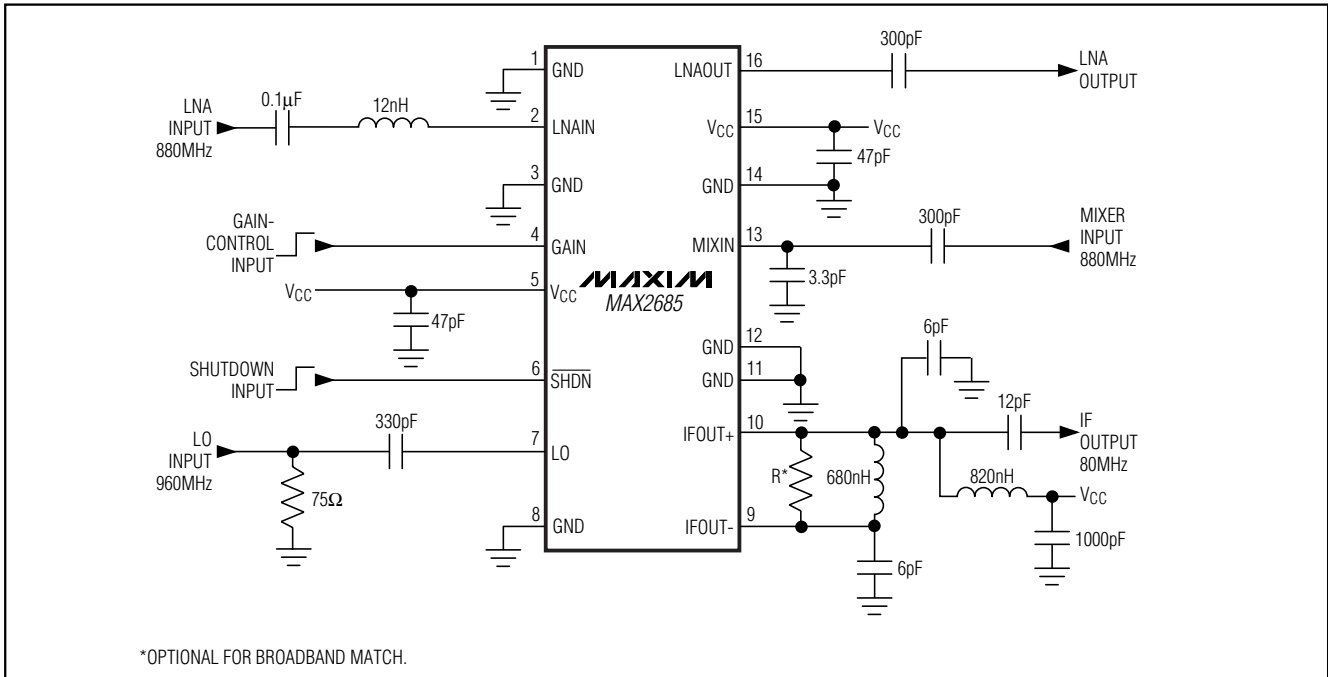

Figure 1. Typical Operating Circuit

Low-Cost, 900MHz, Low-Noise Amplifier and Downconverter Mixer

Detailed Description

The MAX2685 consists of five major components: a low-noise amplifier (LNA), an LNA bypass switch, a downconverter mixer, a local-oscillator (LO) buffer, and a power-management block.

Low-Noise Amplifier (LNA)

The LNA is a wideband, single-ended cascode amplifier that operates over a wide range of frequencies. The input of the LNA (LNAIN) requires an appropriate matching network and a DC-blocking capacitor. The typical operating circuit shown in Figure 1 is optimized for frequencies around 880MHz, requiring only a 0.1 μ F capacitor in series with a 12nH inductor. See Table 1 for the LNA "S" parameters for matching to other frequencies.

The output of the LNA (LNAOUT) is internally biased to VCC. It is internally matched to 50 Ω and incorporates an internal DC-blocking capacitor.

LNA Bypass Switch and Gain Control

When a large input signal is present, enable the LNA bypass function to increase linearity and reduce supply current. Set GAIN low to enable the LNA bypass function.

Receive Mixer

The downconverter mixer is a wideband, single-balanced design with a low noise figure and high linearity. The RF signal at the MIXIN port is mixed with the signal at the LO port, and is downconverted to an IF frequency at the differential IF port.

RF Input

The MIXIN input requires a simple external matching network and a series DC-blocking capacitor. See Figure 1 for a matching network example, optimized for 880MHz operation. Table 2 lists mixer "S" parameters for matching to other frequencies.

Table 1. LNA Typical S-Parameters (VCC = +3V, TA = +25°C)

FREQUENCY (MHz)	S11 MAG	S11 PHASE (degrees)	S21 MAG	S21 PHASE (degrees)	S12 MAG	S12 PHASE (degrees)	S22 MAG	S22 PHASE (degrees)
High-Gain Mode (GAIN = VCC)								
800	0.761	-64.5	4.98	177.9	0.018	-163.7	0.376	-107.3
840	0.753	-68.6	5.06	167.2	0.022	-167.1	0.264	-107.0
880	0.747	-73.2	5.07	156.6	0.026	-171.3	0.172	-94.6
920	0.733	-78.0	4.91	146.6	0.030	-175.7	0.149	-62.9
960	0.719	-82.8	4.68	137.7	0.035	178.0	0.200	-42.4
1000	0.693	-87.5	4.40	130.3	0.039	171.0	0.263	-38.8
Low-Gain Mode (GAIN = GND)								
800	0.625	-45.6	0.188	73.0	0.191	71.9	0.483	-91.3
840	0.621	-48.1	0.195	65.5	0.198	64.2	0.423	-91.3
880	0.619	-50.9	0.199	58.1	0.201	56.7	0.370	-89.9
920	0.611	-53.3	0.200	51.6	0.202	50.3	0.337	-86.1
960	0.608	-55.5	0.200	46.1	0.201	44.7	0.322	-80.9
1000	0.607	-57.5	0.200	41.2	0.200	40.0	0.317	-76.7

Low-Cost, 900MHz, Low-Noise Amplifier and Downconverter Mixer

Table 2. Mixer Typical S-Parameters ($V_{CC} = +3V$, $T_A = +25^{\circ}C$)

RF FREQUENCY (MHz)	S11 MAG	S11 PHASE (degrees)	IF FREQUENCY (MHz)	S22 MAG (IFOUT+ Port Only)	S22 PHASE (IFOUT+ Port Only) (degrees)
High-Gain Mode (GAIN = VCC)					
800	0.355	152.7	10	0.996	-0.4
840	0.352	153.7	40	0.994	-1.8
880	0.351	154.5	80	0.993	-3.2
920	0.349	155.8	110	0.989	-4.2
960	0.352	156.2	170	0.988	-6.2
1000	0.353	156.9	240	0.983	-8.0
Low-Gain Mode (GAIN = GND)					
800	0.275	142.8	10	0.996	-0.5
840	0.268	144.1	40	0.995	-1.8
880	0.262	145.5	80	0.993	-3.2
920	0.255	147.7	110	0.989	-4.2
960	0.254	149.0	170	0.987	-6.2
1000	0.245	156.9	240	0.982	-7.9

Low-Cost, 900MHz, Low-Noise Amplifier and Downconverter Mixer

MAX2685

Local-Oscillator Input

The LO port is the high-impedance input of the local-oscillator buffer. It requires a series DC-blocking capacitor and a shunt resistor to ground to set the input impedance. See the *Typical Operating Characteristics* for a graph of LO Port Return Loss vs. Frequency.

IF Output Port

The mixer's downconverted output appears on the differential IFOUT+ and IFOUT- pins. The differential output can be converted to a single-ended output, as shown in the MAX2685 evaluation kit (EV kit). Refer to the *Detailed Description* in the MAX2685 EV kit data sheet.

Shutdown

Drive $\overline{\text{SHDN}}$ low to disable all device functions and place the MAX2685 in low-power shutdown mode. Drive $\overline{\text{SHDN}}$ high or connect it to VCC to enable all device functions.

Applications Information

Layout Considerations

A properly designed PC board is an essential part of any RF/microwave circuit. Note the IC's high-frequency inputs and outputs, and be sure to decouple the DC supply and control pins.

For power-supply traces and connections, a star topology works well. Each VCC node in the circuit has its own path to the central VCC node and a decoupling capacitor that provides a low impedance at the RF frequency of interest. The central VCC also has a large decoupling capacitor. This provides good isolation between the different sections of the MAX2685.

Chip Information

TRANSISTOR COUNT: 295

Low-Cost, 900MHz, Low-Noise Amplifier and Downconverter Mixer

Package Information

DIM	INCHES		MILLIMETERS	
	MIN	MAX	MIN	MAX
A	.061	.068	1.55	1.73
A1	.004	.0098	0.102	0.249
A2	.055	.061	1.40	1.55
B	.008	.012	0.20	0.31
C	.0075	.0098	0.191	0.249
D	SEE VARIATIONS			
E	.150	.157	3.81	3.99
e	.025 BSC		0.635 BSC	
H	.230	.244	5.84	6.20
h	.010	.016	0.25	0.41
L	.016	.035	0.41	0.89
N	SEE VARIATIONS			
X	SEE VARIATIONS			
Y	.071	.087	1.803	2.209
α	0°	8°	0°	8°

DIM	INCHES		MILLIMETERS		N
	MIN.	MAX.	MIN.	MAX.	
D	.189	.196	4.80	4.98	16 AA
S	.0020	.0070	0.05	0.18	
X	.107	.123	2.72	3.12	
D	.337	.344	8.56	8.74	20 AB
S	.0500	.0550	1.270	1.397	
D	.337	.344	8.56	8.74	24 AC
S	.0250	.0300	0.635	0.762	
D	.386	.393	9.80	9.98	28 AD
S	.0250	.0300	0.635	0.762	
X	.271	.287	6.88	7.29	

NOTES:

- D & E DO NOT INCLUDE MOLD FLASH OR PROTRUSIONS.
- MOLD FLASH OR PROTRUSIONS NOT TO EXCEED .006" PER SIDE.
- HEAT SLUG DIMENSIONS X AND Y APPLY ONLY TO 16 AND 28 LEAD POWER-QSDP PACKAGES.
- CONTROLLING DIMENSIONS: INCHES.
- MEETS JEDEC MO137.

MAXIM
PROPRIETARY INFORMATION
 TITLE: PACKAGE OUTLINE, QSDP, .150", .025" LEAD PITCH
 APPROVAL: _____ DOCUMENT CONTROL NO. 21-0055 REV C 1/1

Maxim cannot assume responsibility for use of any circuitry other than circuitry entirely embodied in a Maxim product. No circuit patent licenses are implied. Maxim reserves the right to change the circuitry and specifications without notice at any time.

10 **Maxim Integrated Products, 120 San Gabriel Drive, Sunnyvale, CA 94086 408-737-7600**

Looking for pricing, stock, or lifecycle information?

Click below to explore more details on WIN SOURCE:

 [View MAX2685EEE+ on WIN SOURCE](#)

 [Maxim Integrated](#) Information

Optimize Your Supply Chain with WIN SOURCE Solutions

-  Global Sourcing Solution
-  Obsolete Management
-  Cost Control Management
-  Shortage Management
-  Alternative Solution
-  Excess Inventory Management