



**THE DATASHEET OF
MAX2172ETL+**



8th Edition

AUTOMOTIVE

Solutions Guide

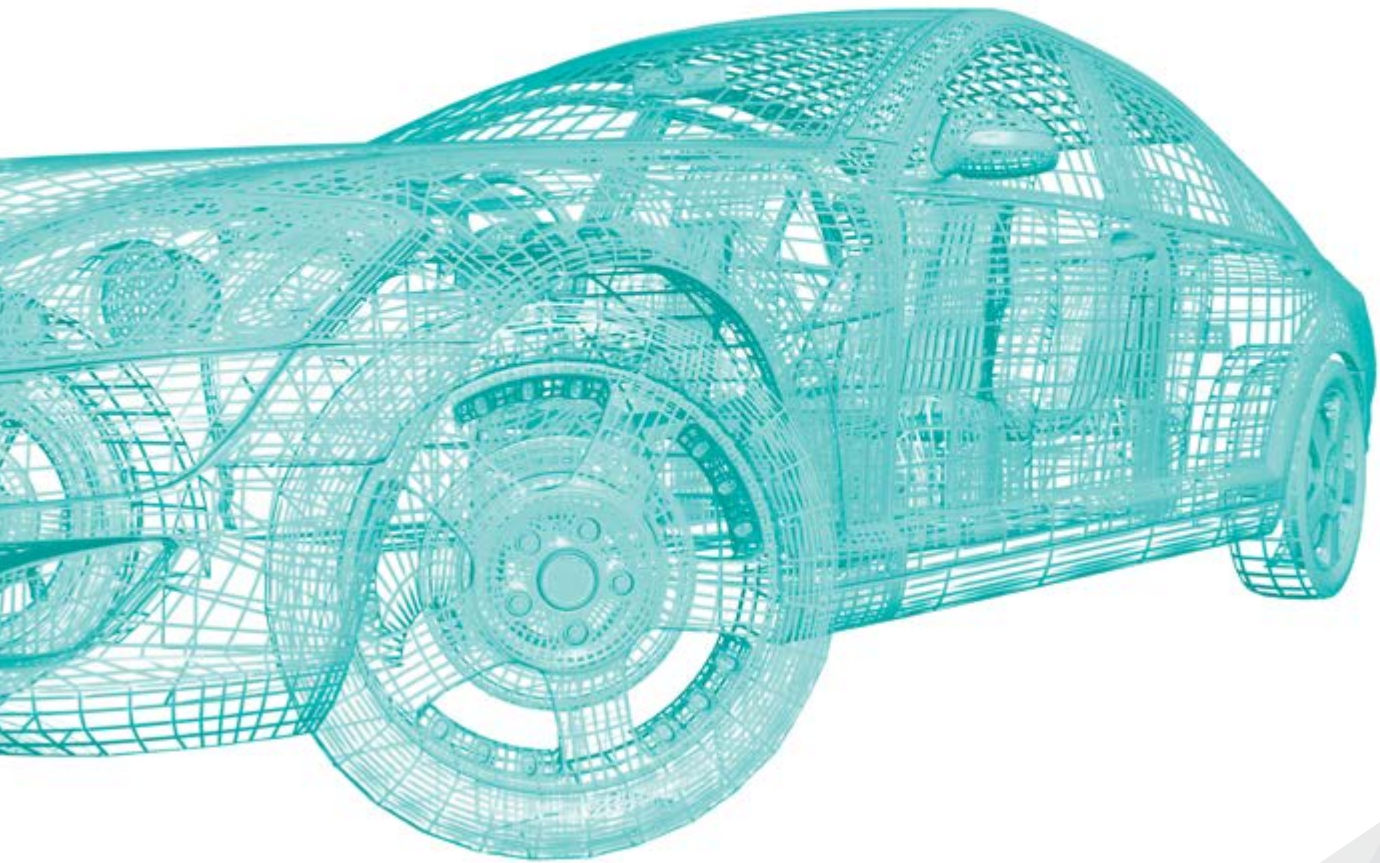

Table of Contents

3	Introduction
4	Infotainment
4	Power Management for Infotainment
6	Displays
8	Radio Head Units
9	Antennas
10	Instrument Clusters
11	Navigation Systems
12	Rear Seat Entertainment
13	TV Tuner Systems
14	GPS
15	Safety
15	Exterior Lighting
16	Driver Assistance Camera
17	Recommended Serializers/Deserializers for Automotive Applications
18	Powertrain
18	A Groundbreaking Approach
19	Robust Body Controls
20	Access
20	Unlock New Possibilities
22	Automotive Quality
23	More Maxim Technology

Introduction

Driving Automotive Technology Further, Faster

Maxim is the analog integration leader. We are a core enabler of the smartphone revolution. Now we're bringing that expertise to our automotive customers, helping them add next-generation capabilities with less development effort and cost.

Infotainment

Deliver More Options and Design-In More Possibilities

- Highly integrated PMICs streamline power architectures
- RF to Bits® tuners enable software-defined radios, increasing flexibility and offloading ECUs
- Industry-leading SerDes and USB solutions increase performance and connectivity
- Integrated solutions for audio, backlighting, timekeeping, etc., free space for new functions

Safety

Reduce Development Costs, Without Compromising Performance or Safety

- GMSL SerDes technology provides a compression-free alternative to Ethernet, delivering 10x faster data rates, 50% lower cabling costs, and better EMC
- LED drivers offer features such as wide dimming ranges, fault tolerance, and EMI reduction circuitry to save space and cost
- High-voltage technologies ensure reliability in harsh automotive conditions

Powertrain

Accelerate to the Mass Market Faster, Smarter

- Centralized isolation architecture substantially reduces system cost
- Built-in self-diagnostics speed ASIL qualification
- Industry-leading sample rate (100/s) maximizes driving range and safety
- Superior noise immunity helps customers pass tough noise tests

Access

Cut Antenna Count in Half, Unlock Keyless-Go Possibilities

- 22kHz BPSK system provides the industry's best range and noise immunity
- Integration yields substantial cost reduction in both the key and car
- Reduced antenna count minimizes component and installation costs
- Integrated 3D active immobilizer enables operation with dead battery

Infotainment

Power Management for Infotainment

Highly Integrated Automotive PMIC (MAX16993) Provides Three Step-Down Outputs

Key Benefits

- High switching frequency and three output rails minimize solution size
- Reduced EMI in car through 2.2MHz spread-spectrum clocking and external syncing capability
- Run directly from the car battery with 36V input voltage and 42V load dump tolerance
- Flexible design with single step-down controller and two 3.0A step-down regulators
- Low I_Q ($< 30\mu\text{A}$) provides a 3x improvement in the power budget, allowing more features to be included

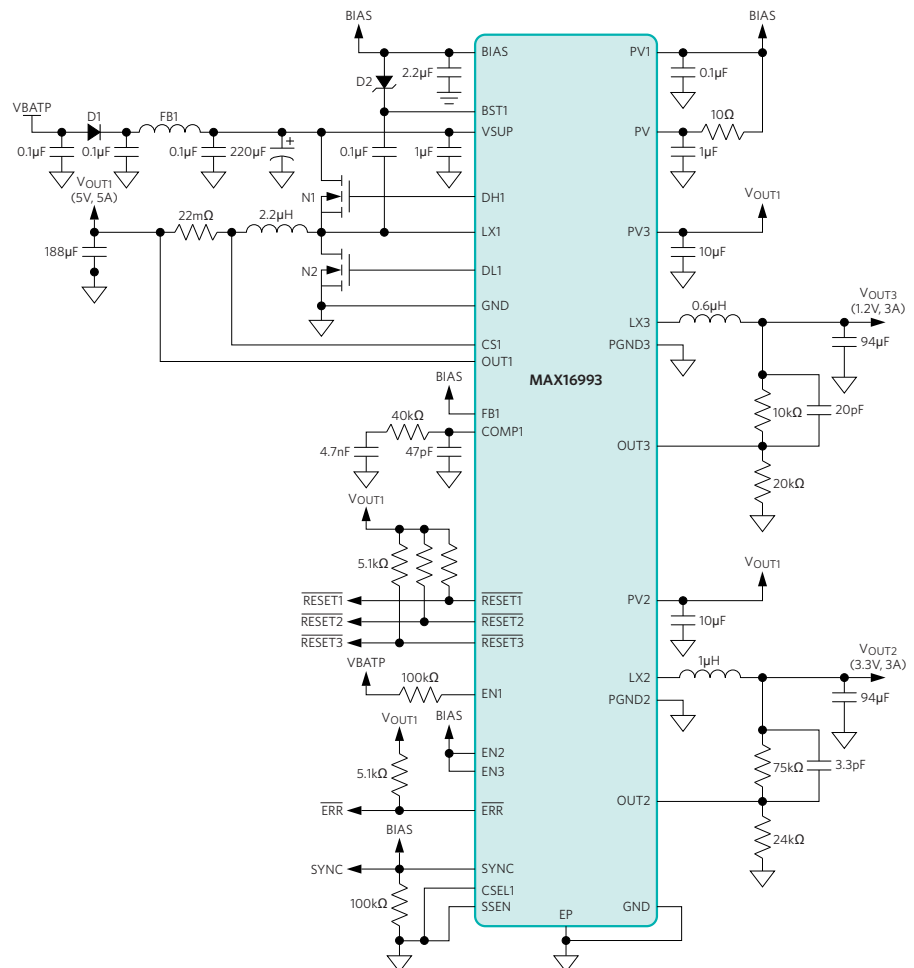

Infotainment

Power Management for Infotainment (cont.)

Automotive-Qualified Switching Regulators Power Next-Generation Infotainment Systems

Key Benefits

- 42V load-dump tolerance allows direct operation from the car battery
- Up to 2.2MHz adjustable switching frequency reduces external component size and optimizes solution cost
- Available spread-spectrum feature lowers EMI to minimize radio interference within the vehicle
- Ultra-low quiescent current in skip mode to meet stringent OEM module standby current requirements
- Wide operating voltage range ensures operation from cold crank to truck battery inputs

High-Voltage Automotive-Qualified Power Products

HV Switching	V _{IN} (V) max	I _{OUT} (A) typ	Maximum f _{SW} (MHz) typ	Spread Spectrum?	I _Q (μA) max	Type
MAX16903	28	1	2.1	Optional	35	
MAX16930	36	Controller	2.2	Optional	40	Dual buck controller with preboost
MAX16931	36	Controller	0.4	Optional	40	Dual buck controller with preboost
MAX16932	36	Controller	2.2	Optional	40	Dual buck controller
MAX16933	36	Controller	0.4	Optional	40	Dual buck controller
MAX16936	36	2.5	2.2	Optional	40	Step-down converter
MAX16952	36	Controller	2.0	No	90	Step-down converter
MAX16956	36	0.3	2.1	Optional	3	Mini buck converter
MAX16990	36	Controller	0.4	Optional	1300	Boost/SEPIC controller
MAX16992	36	Controller	2.2	Optional	2000	Boost/SEPIC controller
MAX16993	36	Depends on version	Depends on version	Optional	45	Step-down controller with dual step-down converters

Low-Voltage Automotive-Qualified Power Products

LV Switching	V _{IN} (V) max	I _{OUT} (A) typ	Maximum f _{SW} (MHz) typ	Spread Spectrum?	I _Q (μA) max	Type
MAX16945	5.5	0.03	0.125	No	1800	Inverting charge pump
MAX16961	5.5	3	2.2	Optional	45	Step-down converter
MAX16963	5.5	1.5	2.2	Optional	45	Dual channel

Linear Regulator Automotive-Qualified Power Products

LDO	V _{IN} (V) max	I _{OUT} (A) typ	ΔV _{DO} (mV) max	I _Q (μA) max	I _Q shutdown (μA) max	Type
MAX16910	30	0.2	600	30	3	Linear regulator
MAX6765	72	0.1	1200	45	7	Linear regulator with supervisor

Infotainment

Displays

Integrated RGB Laser Driver (MAX3601) Enables Compact Heads-Up Displays

Key Benefits

- Drives most red, green, and blue lasers with 167MHz, 8-bit DACs
- Functional integration further saves space by inclusion of SPI or I²C interface, 8-bit gain adjustment, programmable pulse current, and temp sensor
- Low power operation reduces heat in instrument cluster

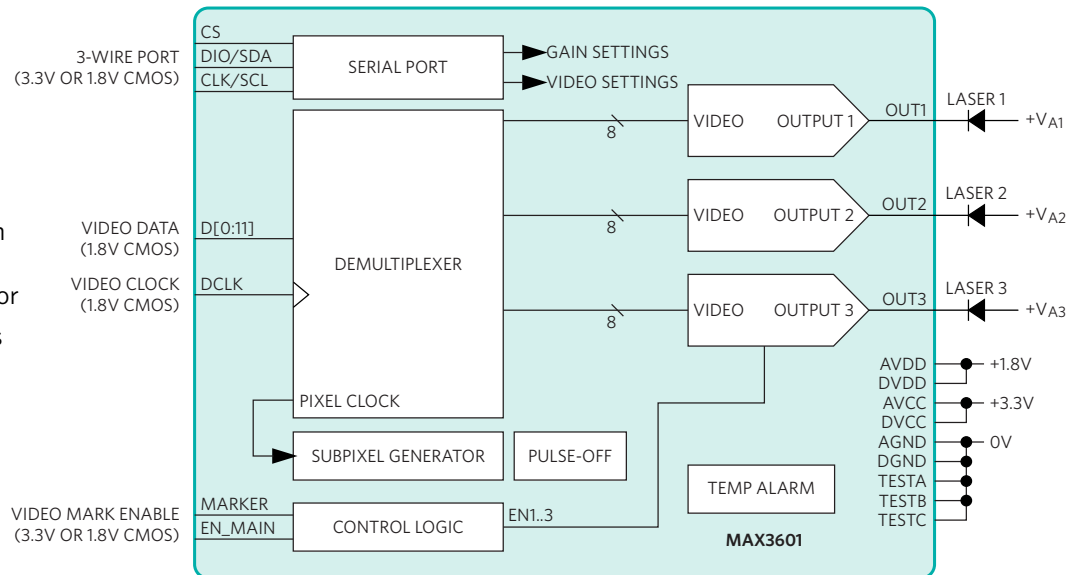

LED Backlight Driver with Wide Dimming Range (MAX16814) Meets Automotive Display Brightness Requirements

Key Benefits

- Supports brightness requirements from daylight to evening with 5000:1 dimming range and up to four strings of LEDs
- Flexible architecture including boost, SEPIC, and coupled inductor operates from automotive battery
- Extends battery life with low quiescent current and adaptive output voltage
- Also see the MAX16826 for a boost converter with flexible LED drive current control

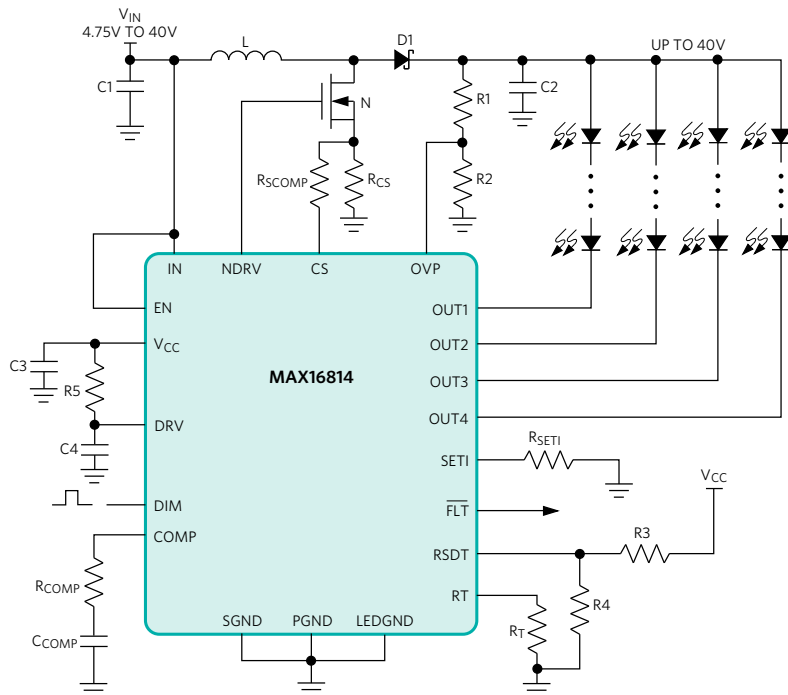

Infotainment

Displays (cont.)

Display Power Supply (MAX16927) Supports Low EMI Environment

Key Benefits

- Complete power supply for display integrates buck, boost, and Cuk converters
- Reduce EMI supported through controllers running out-of-phase and spread-spectrum clocks (external control for the boost and Cuk converters)
- Wide range of displays powered through flexible architecture provide either high power positive supply (+18V/200mA) or moderate power positive and negative supplies (+18V/100mA and -12V/100mA)

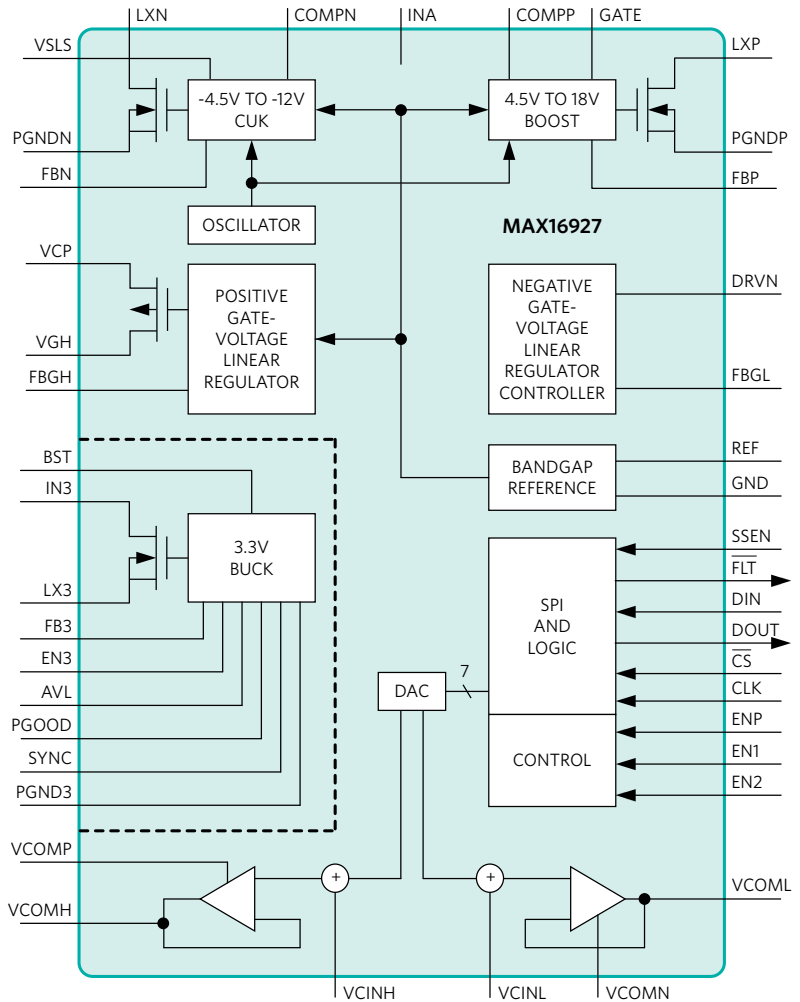

Infotainment

Radio Head Units

Bring it all together—digital radio, embedded telematics, and mobile integration. Analog integration converges all these features into one head unit, offloading ECUs, powering new functions, and providing better interfaces to people and mobile devices.

Direct-Conversion, DAB Tuner (MAX2173) Allows Low-Power, Tuner-On-Board Designs

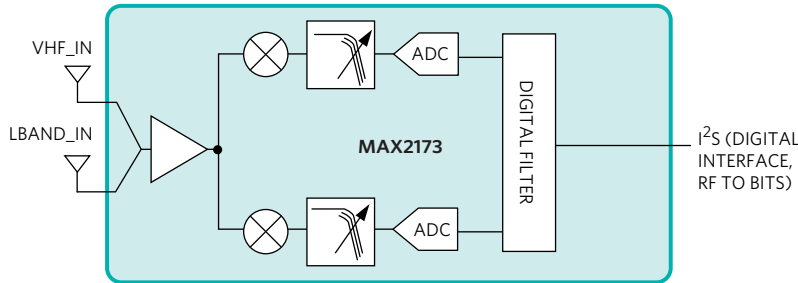

Key Benefits

- Simplified RF to Bits architecture
 - Modularized system and reduced design time
 - Allows the DSP to support other features
- Excellent blocking performance (50dB ACPR) offers static-free reception
- Consumes 50% less power than the competition

Tuners

Part	Supported Standards	Supported Frequency Bands (MHz)	Comments
MAX2171	DAB, T-DMB	168 to 240, 1452 to 1492	Includes clock reference buffer at 1/3 of crystal frequency
MAX2172	DAB, T-DMB	87 to 108, 168 to 240, 1452 to 1492	Includes buffered reference clock
MAX2173	DAB, T-DMB	76 to 90, 87 to 108, 168 to 240, 1452 to 1492	RF to Bits automotive-grade receiver

Automotive-Qualified PMIC (MAX20021) Efficiently Powers Radio Head Unit with Reduced EMI Emissions

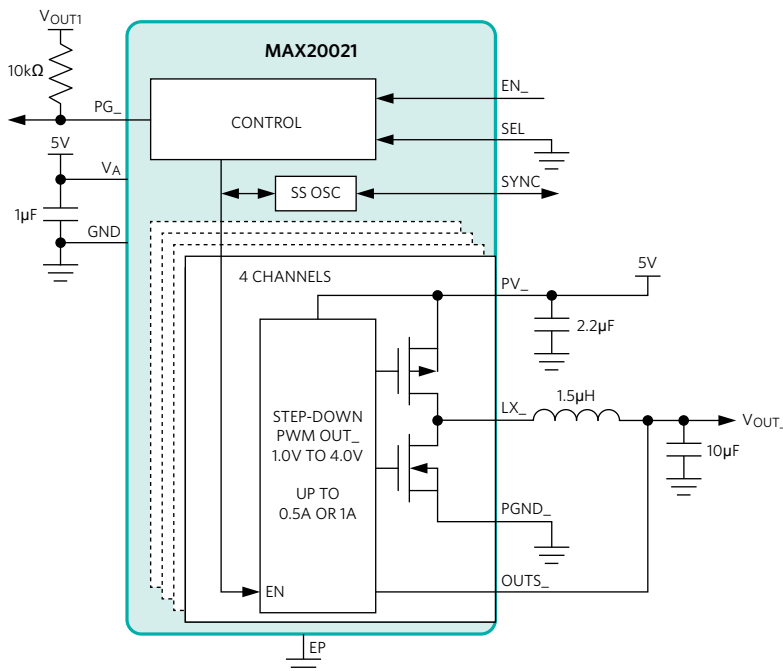

Key Benefits

- Four step-down regulators reduce space and save system cost with up to 1A output capability per regulator
- EMI reduction accomplished through forced-PWM architecture, out-of-phase conversion, SYNC capability, and spread-spectrum option
- Power architecture maintains input voltage tolerances through fast transient response and output voltage accuracy, while minimizing external component size

Infotainment

Antennas

Highly Integrated Active-Antenna Solutions Improve Functionality and Save Space and Cost

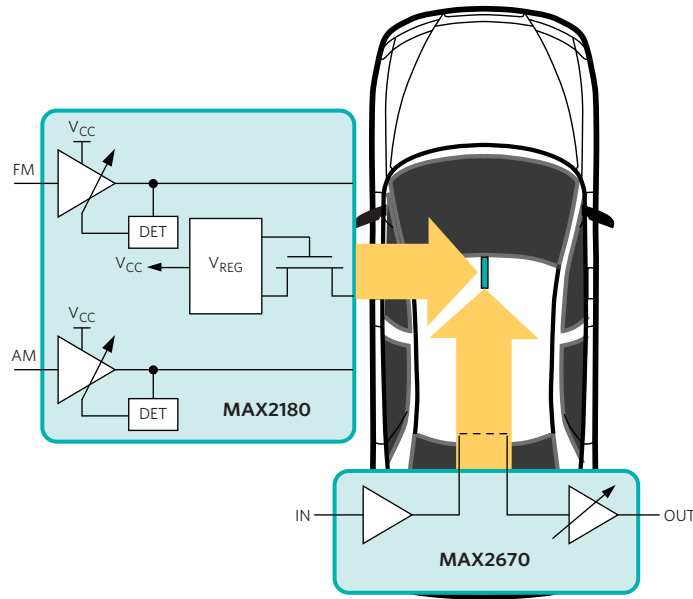

Key Benefits

AM/FM Car Antenna LNA: MAX2180

- Automatic gain control (AGC) and adjustable AGC attack points facilitate very versatile active AM/FM antenna solution for any automotive application
- Highly integrated architecture eliminates need for expensive, unpredictable pin diodes at LNA input
- Cutting-edge CMOS process provides a 6V to 24V operating voltage range

Dual-Stage LNA for GPS/GNSS: MAX2670

- High integration eliminates large, expensive, discrete transistor solutions
- Ultra-low noise figure (1dB, first stage) provides fast GPS lock
- Highly versatile design allows external filtering between first and second stage, providing flexibility for system optimization

Active Antennas

Part	Supported Standards	Supported Frequency Bands (MHz)	Description
MAX2180	AM, FM	148kHz to 30 and 65 to 162.5	Operation from +6V to +24V supports automotive battery operation
MAX2181	FM	76 to 162.5	Operation from +6V to +24V supports battery operation
MAX2181A	FM	76 to 162.5	Runs from single 5V supply, lowering power consumption
MAX2670	GPS/GNSS	1575	

Infotainment

Instrument Clusters

Create infotainment systems that seamlessly integrate with video, navigation, and entertainment systems.

Spread-Spectrum Clock (MAX31180) Supports Wide Frequency Range, Reduces EMI

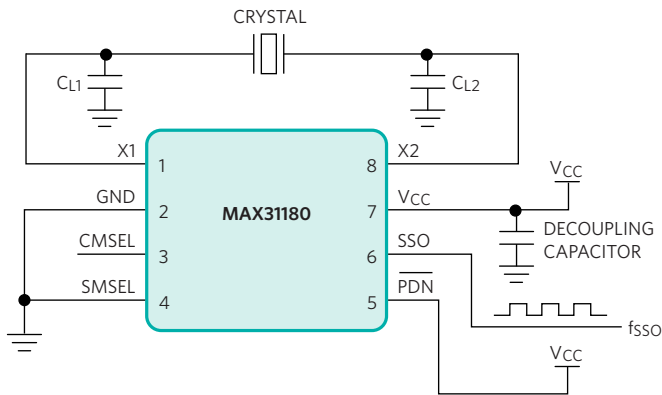

WITH PDN CONNECTED TO VCC, SMSEL CONNECTED TO GND AND CMSEL OPEN, THE DEVICE IS IN NORMAL OPERATION WITH 2x CLOCK MULTIPLICATION, AND SPREAD-SPECTRUM MAGNITUDE OF $\pm 0.5\%$.

Key Benefits

- Supports a wide range of frequency requirements from 16MHz to 134MHz
- Reduces EMI through selectable spread-spectrum ranges

Other Automotive Oscillators

VCO	Frequency Range	Dither Range (%)	Operating Supply Current at 3.0V (mA max)	Comments
DS1086L	33.3MHz to 66.6MHz	0.5 to 8	10	Output enable and power-down mode
DS1090	125kHz to 8MHz	0 to 8L	3	
MAX31180	16MHz to 134MHz	± 0.5 to ± 1.5	15	Power-down and spread-spectrum disable modes

In addition to timing solutions for Instrument Clusters, Maxim Integrated also offers serializers/deserializers for high-speed data transfer. See page 17 for our complete product family.

Infotainment

Navigation Systems

Combine navigation and entertainment systems into a single compact unit.

Integration of USB Connectivity and Power Enables Smaller Designs and Optimizes Compatibility with Portable Devices

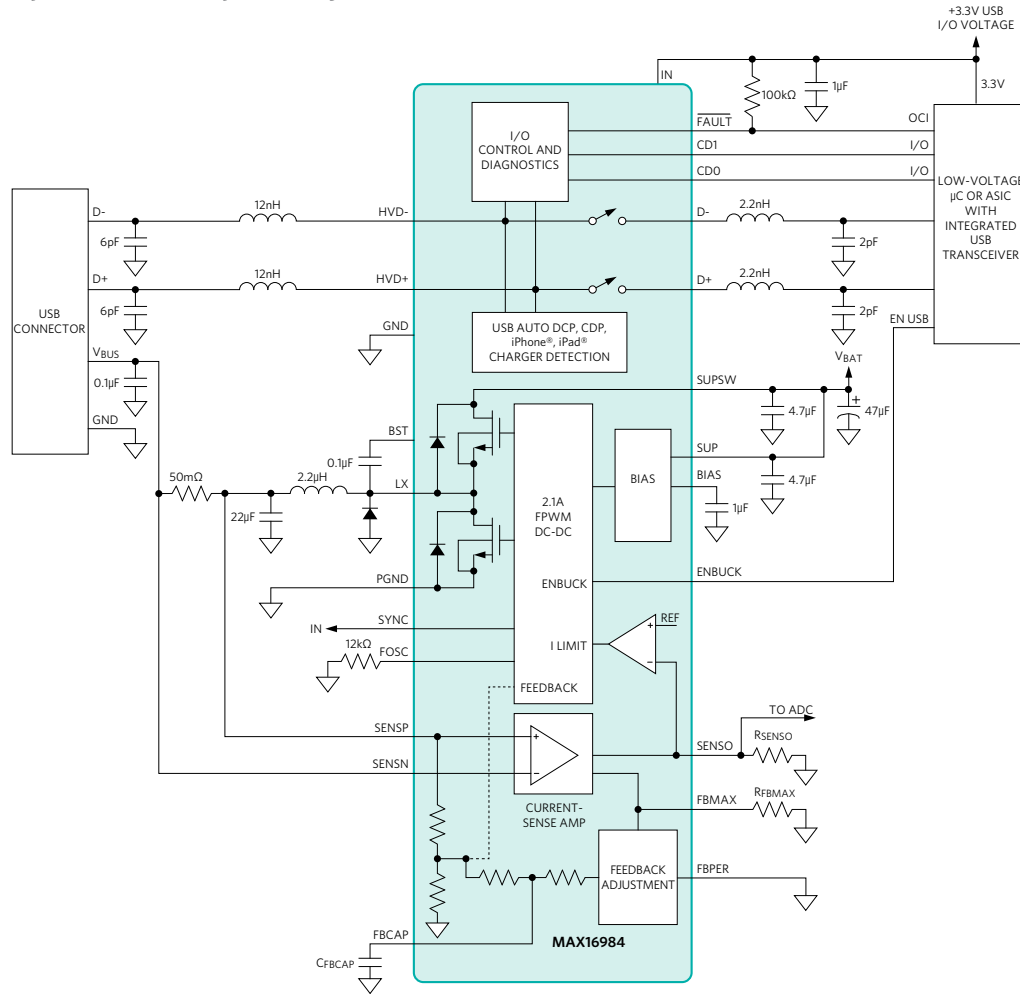

Key Benefits

- Ensures the industry's fastest charge times for integration of USB connectivity and power; enables smaller designs and optimizes compatibility with portable devices
- Integration of USB link and power circuitry plus high efficiency support USB charging capability, while reducing system size
- Low EMI supported with forced-PWM mode and spread-spectrum clock
- Extended battery life due to low I_Q meets need for increasing electronic functionality in the automobile

In addition to timing solutions for Instrument Clusters, Maxim Integrated also offers serializers/deserializers for high-speed data transfer. See page 17 for our complete product family.

Infotainment

Rear Seat Entertainment

Our integrated solutions are transforming automotive entertainment. Helping you deliver a big-screen experience, integrate mobile devices, and power it all, safely and efficiently. With technology this good, you'll be tempted to get out of the driver's seat.

Automotive Connectivity Enabled with Robust ESD Protection and Charging IC

Key Benefits

- Highly integrated charging IC supports USB-IF BC1.2 CDP/DCP modes and Apple iPhone/iPad dedicated rapid charge
- Robust system protection tolerant of 18V without the need for external diodes
- Industry's lowest on-resistance BUS power switch for minimal line drop
- AEC-Q100 qualified

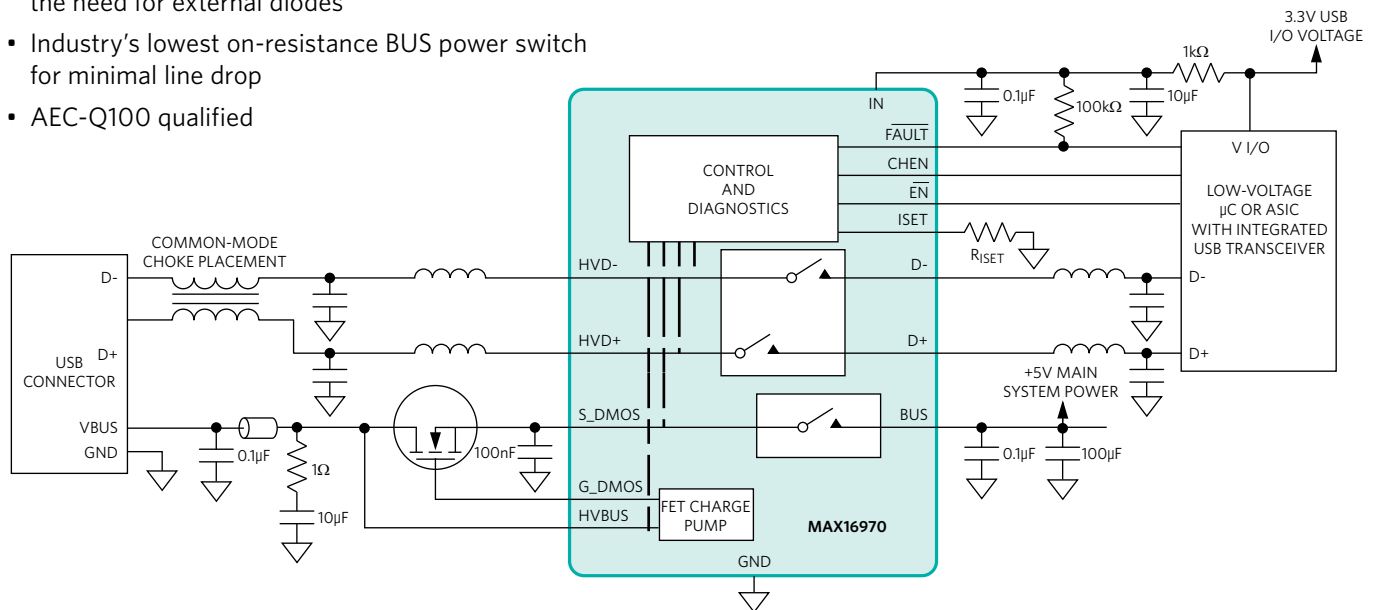

Representative SerDes for Rear Seat Entertainment Systems

Serializers	Input	Output	Data Rate (Gbps)	HDCP?	I _{CC} max (μA)	I _{CC} Sleep max (μA)
MAX9275	LVC MOS	CML	3.12	No	165	170
MAX9279	LVC MOS	CML	3.12	Yes	165	170

Deserializers	Input	Output	Data Rate (Gbps)	HDCP?	I _{CC} max (μA)	I _{CC} Sleep max (μA)
MAX9276	Serial	LVC MOS	3.12	No	305	265
MAX9280	Serial	LVC MOS	3.12	Yes	305	265

In addition to power solutions for Rear Seat Entertainment, Maxim Integrated also offers serializers/deserializers for high-speed data transfer. See page 17 for our complete product family.

Infotainment

TV Tuner Systems

One platform, multiple designs. Use a single design across markets with a multistandard tuner IC. Or, get the flexibility of a software-defined radio with an RF to Bits front-end. Whatever route you take, you'll get in-home-quality reception along with significant space and power savings.

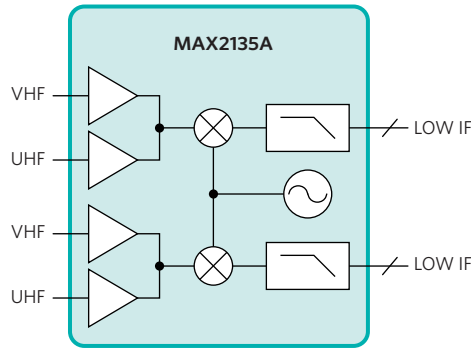

Key Benefits

- High dynamic range provides superior reception (-99dBm to +10dBm)
- 50% smaller footprint (7mm x 7mm) than the competition allows for much smaller designs

Lower Noise Figure and Power at Half the Size of the Competition

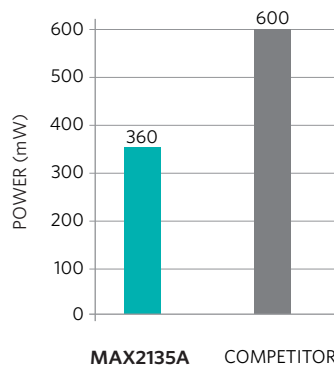
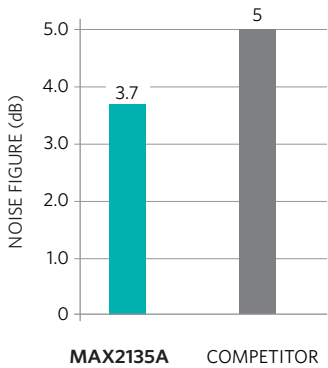

RF to Bits Products for TV Tuners

Part	Supported Standards	Supported Frequency Bands (MHz)	Description
MAX2135A	ISDB-T, DVB-T	93 to 105, 173 to 227, 473 to 859	Diversity ISDB-T/DVB-T tuner
MAX2136A	ISDB-T, DVB-T/T2, T-DMB/DAB, CTTB, CMMB, ATSC/ATSC-MH	44 to 108, 167 to 254, 469 to 891	World-band TV tuner

Infotainment

GPS

Complete GPS, GLONASS, Compass, and Galileo Front-End (MAX2769) Requires No External ADC

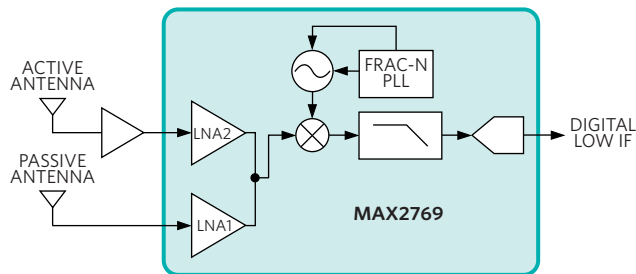

Key Benefits

- Highly integrated RF to Bits receiver eliminates external ADC, thus increasing design flexibility to support any navigation application
- Achieves low 1.4dB noise figure without an external LNA for efficient satellite syncing
- Noise figure falls to 0.8dB when paired with MAX2659

Ultra-Small Leadless Package (MAX2659) Saves Size and Cost

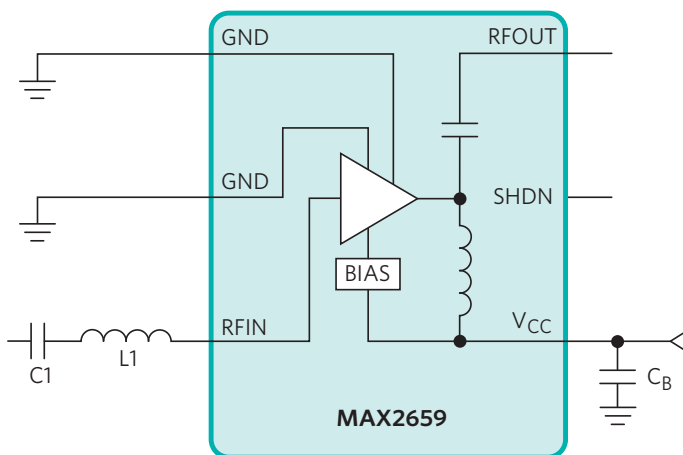

Improves your current GPS receiver's sensitivity

Key Benefits

- High 20.5dB gain
- Ultra-low 0.8dB noise figure
- 4.1mA supply current
- 1.6V to 3.3V supply voltage
- Integrated 50Ω output-matching circuit
- Ultra-small, RoHS-compliant, lead-free, 1.5mm x 1.0mm, 6-pin μDFN package

INPUT MATCH L1 = 6.5nH
 INPUT DC BLOCK C1 = 1800pF
 SUPPLY BYPASS C_B = 33nF

Safety

Exterior Lighting

Whatever your reason for upgrading to LEDs, our integrated drivers help you outshine the competition. They're equipped with features such as fault protection and frequency dithering, EMI reduction, and wide dimming ranges. So you're equipped to deal with anything the road throws at you.

Complete Solution for Single-Chain LED Headlamps Provides Flexibility Without Sacrificing EMI Performance

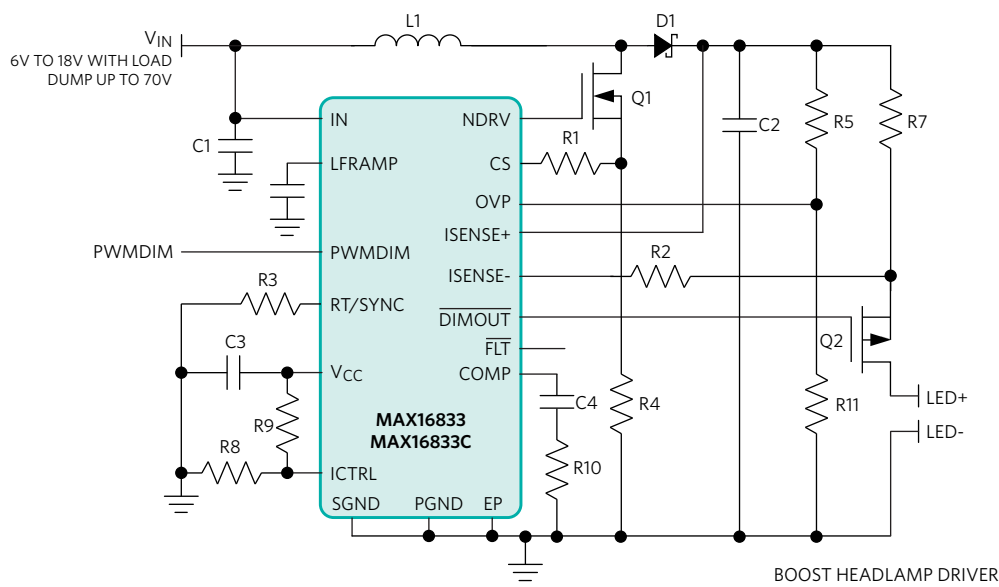

Key Benefits

- Flexible HB LED driver supports boost, buck-boost, SEPIC, and high-side buck topologies and analog or PWM dimming
- Reduced EMI with optional spread-spectrum support and programmable operating frequency with synchronization capability
- Robust performance supported up to 65V

HB LED Drivers

HV Switching	V _{IN} (V) max	Maximum f _{SW} (MHz)	Spread Spectrum
MAX16833	65	1	Yes
MAX16833B	65	1	No
MAX16833C	65	1	Yes
MAX16833D	65	1	No
MAX16834	28	1	No

Safety

Driver Assistance Camera

Remove the lag from your system with GMSL SerDes technology. Designed as a compression-free alternative to Ethernet, our GMSL solutions deliver 10x faster data rates and better EMC performance.

Serializer/Deserializer Family Supports Uncompressed In-Car Video While Reducing Cost and Minimizing EMI

Key Benefits

- Powered coax capability simplifies installation and lowers system cost
- Megapixel cameras supported with high-speed data serialization/deserialization
- Reduces EMI with internal spread-spectrum clock and ability to track spread spectrum on parallel input

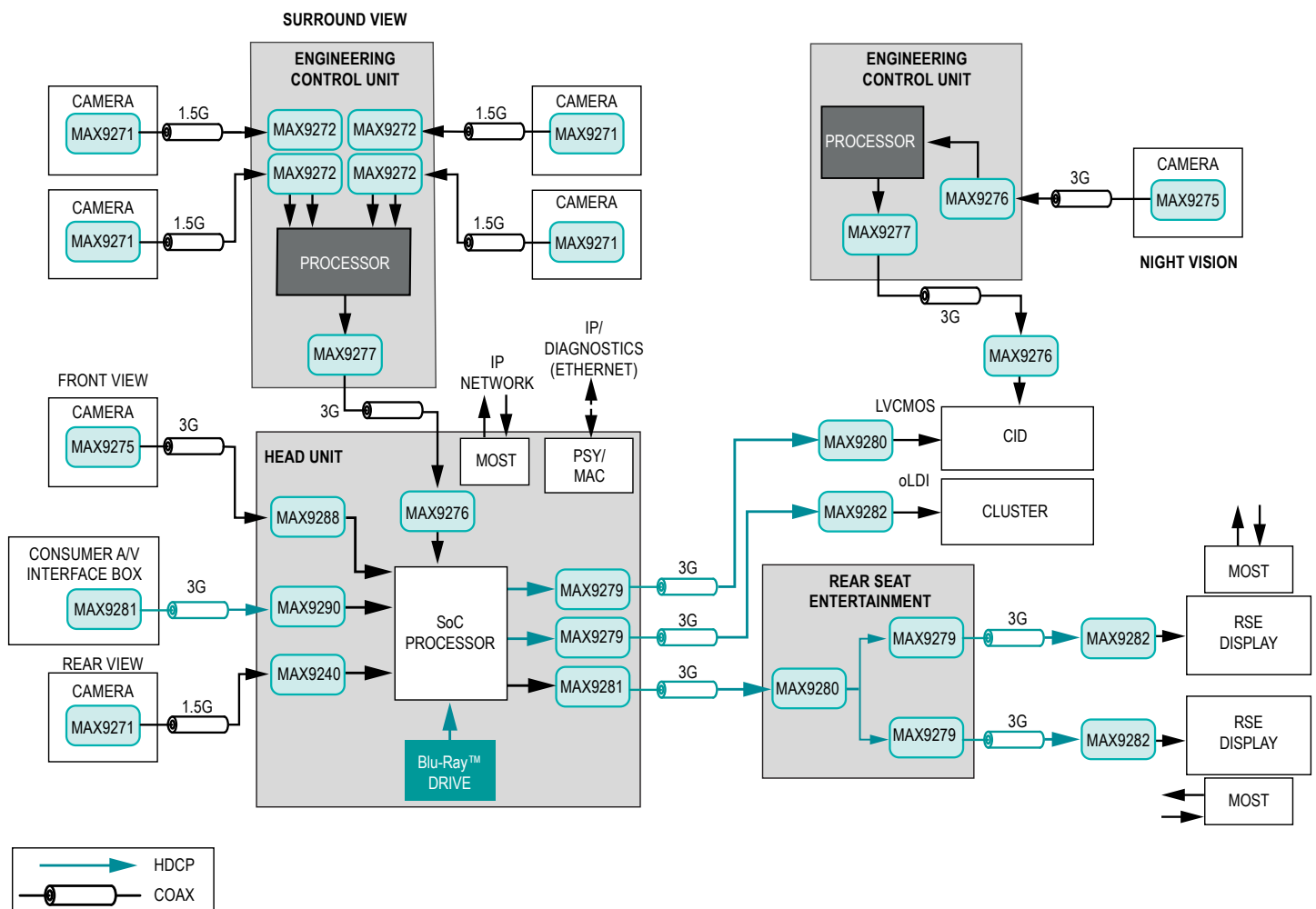

Safety

Recommended Serializers/ Deserializers for Automotive Applications

Serializers	Input	Output	Data Rate (Gbps)	HDCP?	I _{CC} max (mA)	I _{CC} Sleep max (μA)
MAX9271	LVC MOS	CML	1.5	No	75	100
MAX9275	LVC MOS	CML	3.12	No	165	170
MAX9277	LVDS	CML	3.12	No	195	170
MAX9279	LVC MOS	CML	3.12	Yes	165	170
MAX9281	LVDS	CML	3.12	Yes	195	170

Deserializers	Input	Output	Data Rate (Gbps)	HDCP?	I _{CC} max (mA)	I _{CC} Sleep max (μA)	Comments
MAX9240A	Serial	LVC MOS	1.5	No	90	100	Line fault detection
MAX9272A	Serial	LVC MOS	1.5	No	90	100	
MAX9276	Serial	LVC MOS	3.12	No	305	265	
MAX9278	Serial	LVDS	3.12	No	300	300	
MAX9280	Serial	LVC MOS	3.12	Yes	305	265	
MAX9282	Serial	LVDS	3.12	Yes	300	300	
MAX9288	Serial	CSI-2	3.12	No	300	120	
MAX9290	Serial	CSI-2	3.12	Yes	300	120	

Powertrain

A Groundbreaking Approach

Maxim’s centralized isolation architecture only requires one pair of isolation transformers per daisy chain. Giving you the lowest system cost, faster ASIL qualification, longer driving ranges, and extended battery service life.

Robust Battery Management Solution Increases Safe Operation of Li-Ion Battery Packs, While Reducing System Cost

Key Benefits

- Enhanced safety with redundancy through multichip approach
- Lower system cost with daisy-chain communication link

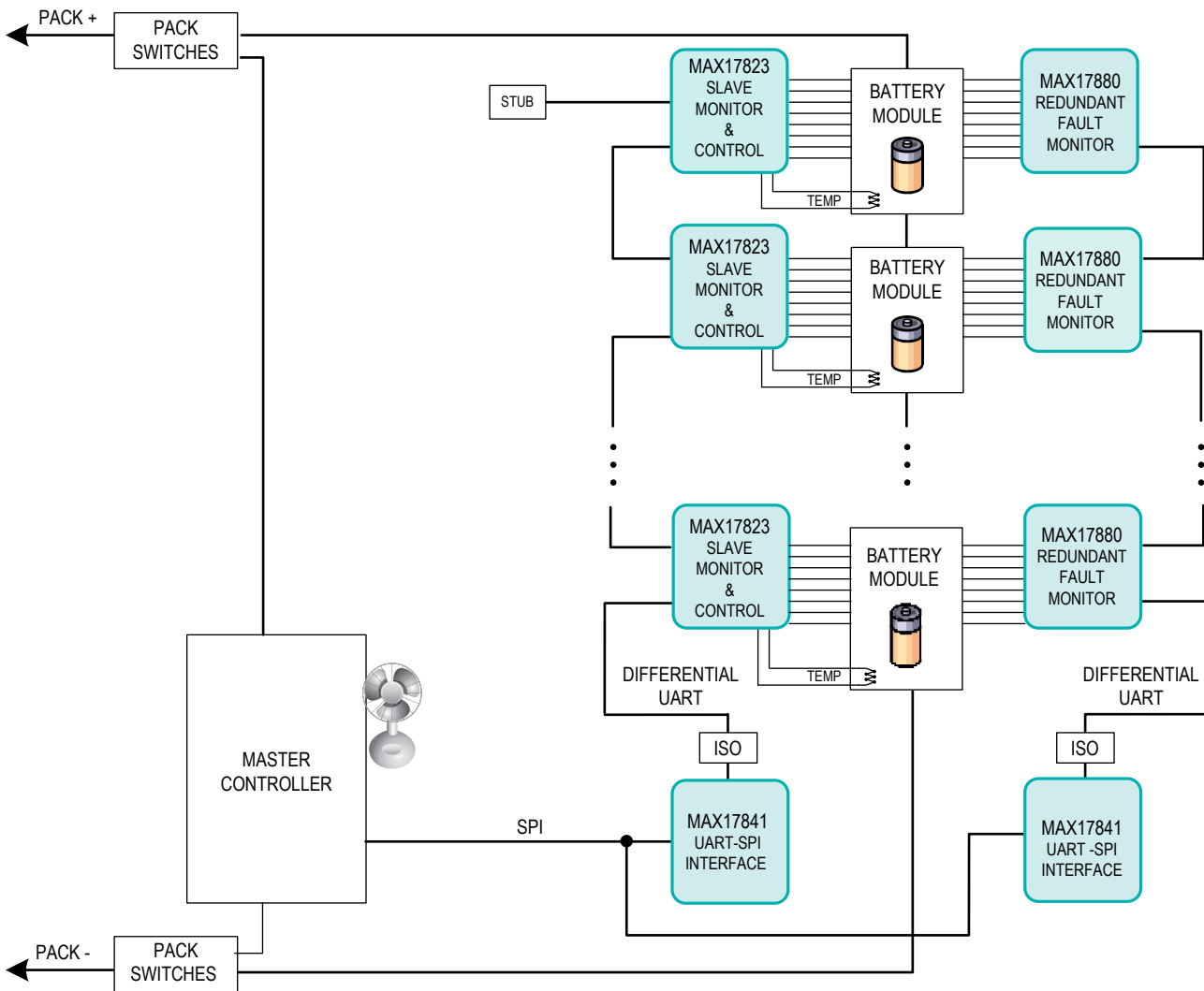

Powertrain

Robust Body Controls

2-Wire Hall-Effect Sensor Interface Solution (MAX9921)
Saves Space and Cost in Automotive Applications

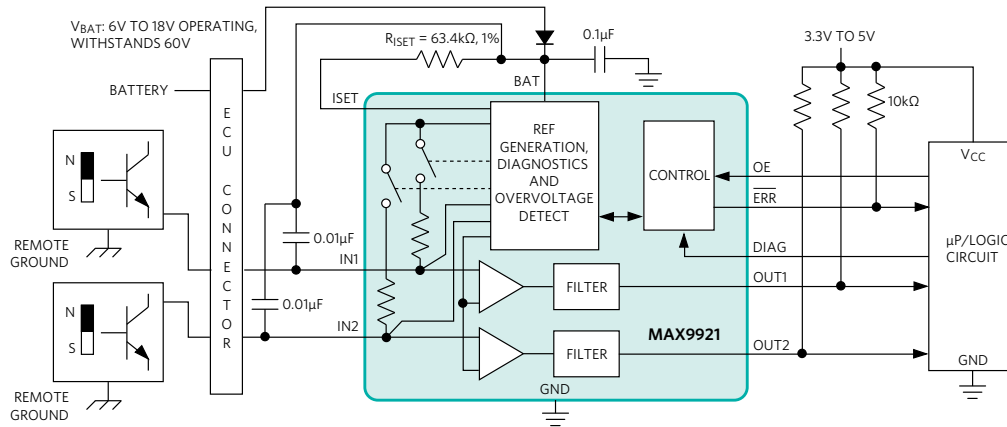

NOTE: FOR BOTH ANALOG AND DIGITAL OUTPUT, REFER TO THE MAX9621.

Key Benefits

- Integrates up to 10 discrete components and eliminates the requirement for a ground return for the sensor
- Provides robust automotive performance by supporting load dump voltages up to 60V and ±15kV ESD protection

Robust Current-Sense Amplifiers (MAX9918/MAX9920)
Ideal for Automotive Motor Control Applications

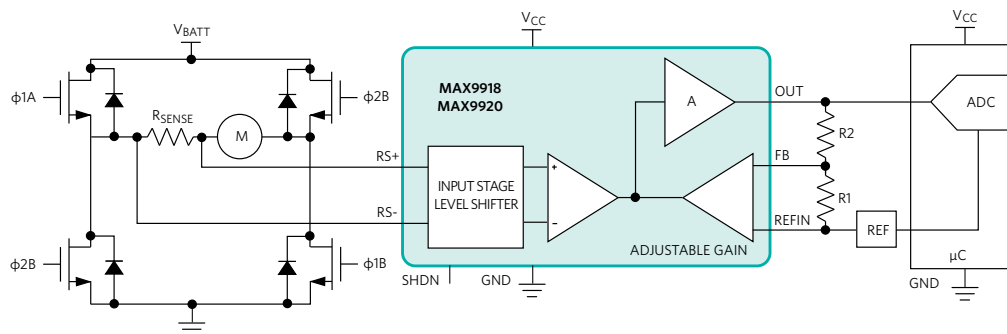

Key Benefits

- Improved immunity to flyback due to -20V to +70V common-mode range provides robust sensing of inductive loads such as motors and solenoids
- Sense resistor power loss is reduced with low input-offset voltage (400µV max)

Access

Unlock New Possibilities

Keyless-Go Cuts Antenna Count in Half

Maxim’s keyless-go solution operates at 22kHz to provide the best range and noise immunity available, so you can use fewer antennas and have more placement flexibility. And with our comprehensive design-in support, you can get started on your keyless system today.

Reduce Cost, Extend Range and Performance

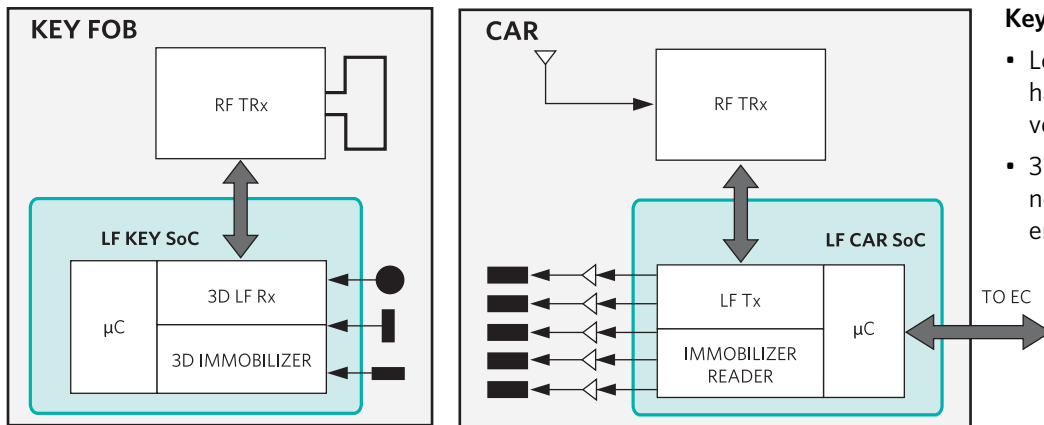

Key Benefits

- Low-frequency keyless-go system halves the number of antennas in vehicle, reducing overall solution cost
- 3D active immobilizer eliminates the need for an immobilizer key slot and enhances the dashboard design

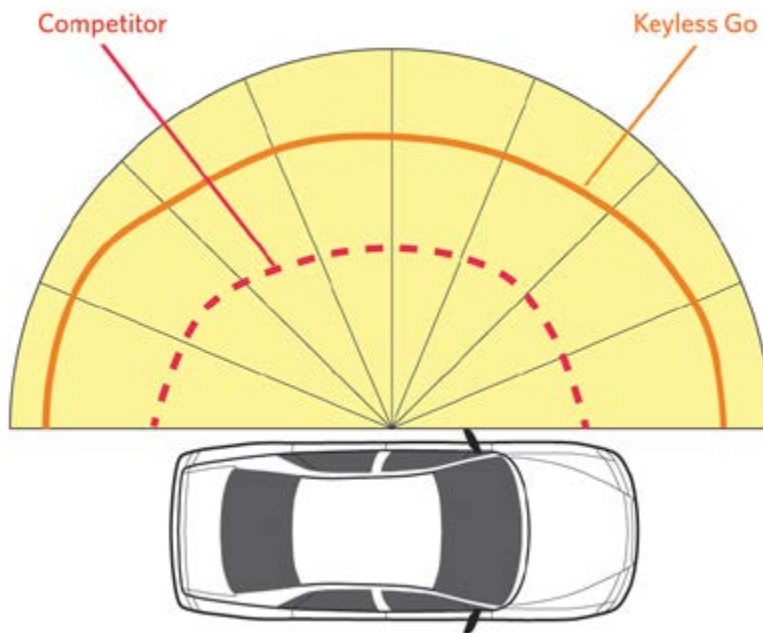

Access

Unlock New Possibilities (cont.)

RKE at Your Fingertips

Highly Integrated Superheterodyne Receivers Reduce Size and Cost of RKE Systems

Key Benefits

- Low power consumption extends battery life without sacrificing performance

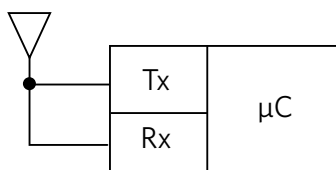

Remote Keyless Entry Receivers/Transmitters

Part	Receiver or Transmitter?	Modulation	Frequency Range (MHz)	Operating Supply Current at 3.0V (mA max)	Input Sensitivity	Comments
MAX1471	Rx	ASK, FSK	300 to 450	8.6	ASK: -114dBm at 280MHz FSK: -108dBm at 280MHz	Integrated image rejection
MAX7034	Rx	ASK	300 to 450	8.7 (at 5V)	-114dBm at 315MHz -113dBm at 434MHz	Integrated image rejection
MAX7036	Rx	ASK, OOK	300 to 450	7.3	-109dBm at 315MHz -107dBm at 434MHz	Integrated AGC and IF filter
MAX7042	Rx	FSK	308, 315, 418, 433.92	8.6	-110dBm at 315MHz -109dBm at 434MHz	Integrated image rejection
MAX7057	Tx	ASK, FSK	300 to 433.92	22.4	N/A	Supports data rates up to 100 kbps (NRZ)
MAX7060	Tx	ASK, FSK	280 to 450	31.6	N/A	Supports data rates up to 140 kbps (NRZ)

Automotive Quality

Automotive "V" Flow Drives Products to Zero Defects

Maxim's automotive "V" flow is more than an AEC-Q100 report and a PPAP. This program delivers a comprehensive suite of benefits required for success in the automotive market.

Key Benefits

- AEC-Q100 qualification and PPAP reports
- Automotive launch compliance over product's complete temperature range
- Prioritized failure analysis for quick response
- Higher Cpk (> 1.67) fab processes to ensure high inherent silicon quality
- Bill of material and manufacturing controls to ensure qualified production support
- Extended product change notification (PCN) horizon
- Restriction to \leq two qualified production sites for wafer, assembly, and test
- Global failure analysis support centers
- Worldwide field quality support
- Full ISO/TS 16949:2002- and ISO 9001:2008-certified quality management system
- Full ISO 14001:2004-certified environmental management system

When ordering, select Maxim's "/V" products for automotive qualified devices.

More Technology

In addition to the products featured in this guide, Maxim Integrated offers a wide range of automotive-qualified products and technologies that help make the next-generation automobile a reality.

Amplifiers and Sensors

- Current-Sense Amplifiers
- Hall-Effect and VR Sensor Interfaces
- Op Amps/Comparators

Audio and Video Products

- Audio Amplifiers
- Audio Auxiliary Inputs
- Headphone Drivers
- Speaker Drivers
- Video Line Drivers and Receivers
- Video Muxes and Crosspoints

Clocks

- Real-Time Clocks and Timekeeping ICs

Data Converters and Sample-and-Holds

- Analog-to-Digital Converters
- Digital-to-Analog Converters

Interface and Interconnect

- Antenna Switches
- CAN, LIN 2.0, SAE J2602, LVDS ICs
- USB ICs and Protection Circuits

Power Supplies/Battery Management

- Battery Chargers
- Battery Protectors, Selectors, Monitors
- Low-Side/High-Side MOSFET Drivers
- ORing MOSFET Drivers
- Reset Circuits

Wireless, RF, GPS

- IF I/Q Demodulators/Modulators
- IF Transceivers
- Low-Noise Amplifiers (LNAs)
- Power Amplifiers/Drivers
- RF and IF Variable-Gain Amplifiers
- RF Power Detectors/Predistortion ICs
- RF Transceivers
- Vector Modulators/Multipliers
- Voltage-Controlled Oscillators (VCOs)
- VCO Buffers

Blu-Ray is a trademark of Blu-Ray Disc Association.

iPhone and iPad are registered trademarks of Apple, Inc.

RF to Bits is a registered trademark and service mark of Maxim Integrated Products, Inc.

Contact Maxim Direct at 1.888.629.4642 or for more information, visit www.maximintegrated.com.

© 2014 Maxim Integrated Products, Inc. All rights reserved. Maxim Integrated and the Maxim Integrated logo are trademarks of Maxim Integrated Products, Inc., in the United States and other jurisdictions throughout the world. All other company names may be trade names or trademarks of their respective owners.

Rev 0; April 2014



Looking for pricing, stock, or lifecycle information?

Click below to explore more details on WIN SOURCE:

 [View MAX2172ETL+ on WIN SOURCE](#)

 [Maxim Integrated](#) Information

Optimize Your Supply Chain with WIN SOURCE Solutions

-  Global Sourcing Solution
-  Obsolete Management
-  Cost Control Management
-  Shortage Management
-  Alternative Solution
-  Excess Inventory Management