



**THE DATASHEET OF
MAX16024LTBS+**





Battery-Backup Circuits with Regulated Output Voltage

MAX16023/MAX16024

General Description

The MAX16023/MAX16024 low-power battery-backup circuits with a regulated output are capable of delivering up to 100mA output current. The MAX16023/MAX16024 include a low-dropout regulator, a microprocessor (μ P) reset circuit, and a battery switchover circuit. Additional available features include a manual reset, a power-fail comparator, and a battery-on indicator. These devices reduce the number of external components to minimize board space and improve reliability.

The MAX16023/MAX16024 are ideally suited for providing power for backing up critical memory such as static random-access memory (SRAM) or real-time clocks (RTCs). The regulated output is powered by V_{CC} when it is present and switches over to the backup power during brownout. The MAX16023/MAX16024 accept an input voltage from 1.53V to 5.5V and provide fixed standard output voltages of 1.2V, 1.8V, 2.5V, 3.0V, and 3.3V. The MAX16024 offers the ability to externally set the output voltage using a resistive divider. All outputs are available with push-pull or open-drain configurations.

The MAX16023 offers a power-fail comparator for monitoring an additional voltage or for providing an early power-fail warning. Another feature includes a manual-reset input (MAX16023/MAX16024). The MAX16024 also features a battery-on indicator and chip-enable gating function.

The MAX16023/MAX16024 are offered in 8- and 10-pin TDFN packages and are fully specified from -40°C to $+85^{\circ}\text{C}$ temperature range.

Applications

Main/Backup Power for RTCs/SRAM
Industrial Controls
GPS Systems
Set-Top Boxes
Point-of-Sale Equipment
Portable/Battery Equipment

UL is a registered trademark of Underwriters Laboratories, Inc.

Features

- ◆ System Monitoring for 5V, 3.3V, 3V, 2.5V, or 1.8V Power-Supply Voltages
- ◆ 100mA Low-Dropout Regulator
- ◆ Factory-Trimmed and Adjustable Output Voltages
- ◆ 1.53V to 5.5V Operating Voltage Range
- ◆ Low-Power Consumption: 4 μ A (typ)
- ◆ Power-Fail Comparators for Monitoring Voltages Down to 0.6V
- ◆ Battery-On Indicator
- ◆ Battery Freshness Seal
- ◆ On-Board Gating of CE Signals, 1.5ns Propagation Delay (MAX16024)
- ◆ Debounced Manual-Reset Input
- ◆ 145ms (min) Reset Timeout Period
- ◆ Tiny 8-Pin and 10-Pin TDFN Packages
- ◆ UL[®] Certified to Conform to IEC 60950-1

Ordering Information

PART	TEMP RANGE	PIN-PACKAGE
MAX16023_TA__+T	-40°C to $+85^{\circ}\text{C}$	8 TDFN-EP*
MAX16024_TB__+T	-40°C to $+85^{\circ}\text{C}$	10 TDFN-EP*

The first placeholder “_” designates reset output options. A letter “L” in this placeholder indicates a push-pull output and letter “P” indicates an open-drain output. The next placeholder “_” designates the reset threshold (Table 1). The last two placeholders “_” designate output voltage (Table 2). For the MAX16024 with adjustable output voltage version, there are no last two placeholders.

+Denotes a lead-free/RoHS-compliant package.

T = Tape and reel.

*EP = Exposed pad.

Pin Configurations

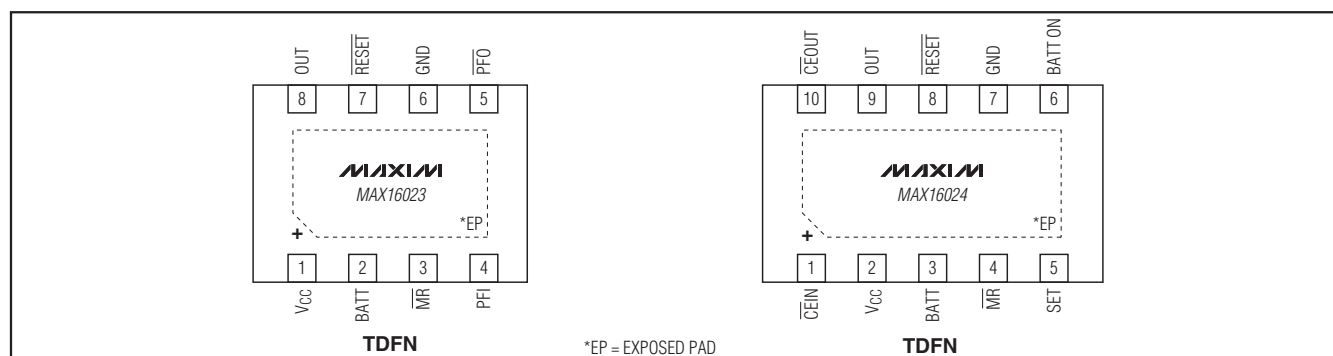

Battery-Backup Circuits with Regulated Output Voltage

ABSOLUTE MAXIMUM RATINGS

V_{CC} , BATT, OUT to GND.....	-0.3V to +6V
RESET, PFO, BATT ON (all open drain) to GND.....	-0.3V to +6V
RESET, PFO, BATT ON (all push-pull) to GND	-0.3V to ($V_{OUT} + 0.3V$)
PFI, CEIN, CEOUT to GND.....	-0.3V to ($V_{OUT} + 0.3V$)
MR to GND	-0.3V to ($V_{CC} + 0.3V$)
Input Current	
V_{CC} Peak Current.....	1A
V_{CC} Continuous Current	250mA
BATT Peak Current	500mA
BATT Continuous Current	70mA

Output Current	
OUT Short Circuit to GND Duration	10s
RESET, BATT ON, CEOUT.....	20mA
Continuous Power Dissipation ($T_A = +70^\circ\text{C}$)	
8-Pin TDFN (derate 24.4mW/ $^\circ\text{C}$ above $+70^\circ\text{C}$)	1951mW
10-Pin TDFN (derate 24.4mW/ $^\circ\text{C}$ above $+70^\circ\text{C}$)	1951mW
Thermal Resistance (Note 1)	
θ_{JA} (8-Pin and 10-Pin TDFN).....	41 $^\circ\text{C}/\text{W}$
Operating Temperature Range	-40 $^\circ\text{C}$ to +85 $^\circ\text{C}$
Junction Temperature.....	+150 $^\circ\text{C}$
Storage Temperature Range	-65 $^\circ\text{C}$ to +150 $^\circ\text{C}$
Lead Temperature (soldering, 10s)	+300 $^\circ\text{C}$

Note 1: Package thermal resistances were obtained using the method described in JEDEC specification JESD51-7, using a four-layer board. For detailed information on package thermal considerations, refer to www.maxim-ic.com/thermal-tutorial.

Stresses beyond those listed under "Absolute Maximum Ratings" may cause permanent damage to the device. These are stress ratings only, and functional operation of the device at these or any other conditions beyond those indicated in the operational sections of the specifications is not implied. Exposure to absolute maximum rating conditions for extended periods may affect device reliability.

ELECTRICAL CHARACTERISTICS

($V_{CC} = 1.53V$ to $5.5V$, $V_{BATT} = 3V$, reset not asserted, $T_A = T_J = -40^\circ\text{C}$ to $+85^\circ\text{C}$, $C_{OUT} = 10\mu\text{F}$, unless otherwise noted. Typical values are at $T_A = T_J = +25^\circ\text{C}$.) (Note 2)

PARAMETER	SYMBOL	CONDITIONS	MIN	TYP	MAX	UNITS	
Operating Voltage Range	V_{CC} , V_{BATT}	(Note 3)	1.53		5.5	V	
Supply Current	I_{CC}	$V_{CC} = \text{LDO} + 0.5V$, no load	LDO = 1.2V	4.3	6	μA	
			LDO = 1.8V	4.7	7		
			LDO = 2.5V	5.2	7.5		
			LDO = 3V	5.5	8		
			LDO = 3.3V	5.7	8		
		$V_{CC} = \text{LDO} + 0.5V$, $I_{OUT} = 20\text{mA}$	LDO = 1.2V	16	20		
			LDO = 1.8V	16	21		
			LDO = 2.5V	16	18.1		
			LDO = 3V	17	18.6		
			LDO = 3.3V	17	19		
Supply Current in Battery-Backup Mode	I_{BATT}	$V_{CC} = 0$, $V_{BATT} = 3V$, no dropout, no load		3.5	5.26	μA	
BATT Standby Current		$V_{CC} > V_{BATT} + 0.2V$	-0.01		+0.01	μA	
SET Reference Voltage	V_{SET}	MAX16024_TB_, $V_{CC} = 2.2V$	1.144	1.2	1.272	V	
SET Input Leakage Current		MAX16024_TB_, SET = 1.2V	-20		+20	nA	
Output Voltage Range	V_{OUT}	MAX16024_TB_, $V_{CC} > V_{OUT}$	1.8		5.25	V	
Output Voltage Accuracy		$I_{OUT} = 1\text{mA}$	LDO = 1.2V	1.145	1.2	1.270	V
			LDO = 1.8V	1.704	1.8	1.900	
			LDO = 2.5V	2.368	2.5	2.634	
			LDO = 3V	2.837	3	3.165	
			LDO = 3.3V	3.114	3.3	3.482	

Battery-Backup Circuits with Regulated Output Voltage

MAX16023/MAX16024

ELECTRICAL CHARACTERISTICS (continued)

($V_{CC} = 1.53V$ to $5.5V$, $V_{BATT} = 3V$, reset not asserted, $T_A = T_J = -40^{\circ}C$ to $+85^{\circ}C$, $C_{OUT} = 10\mu F$, unless otherwise noted. Typical values are at $T_A = T_J = +25^{\circ}C$.) (Note 2)

PARAMETER	SYMBOL	CONDITIONS	MIN	TYP	MAX	UNITS
Line Regulation		$V_{CC} = (V_{OUT} + 1V)$ to $(V_{OUT} + 2V)$, $I_{OUT} = 1mA$		0.2	1.0	%/V
Load Regulation		$V_{CC} = V_{OUT} + 1V$, $I_{OUT} = 1mA$ to $2mA$		0.15	1.0	%
Dropout Voltage		$I_{OUT} = 50mA$ (Note 4)	LDO = 1.2V	500		mV
			LDO = 1.8V	200		
			LDO = 2.5V	180		
			LDO = 3V	150		
			LDO = 3.3V	150		
Output Current Limit		$V_{CC} = 1.6V$		75		mA
		$V_{CC} \geq 2V$		150		
Battery Freshness Leakage Current		$V_{BATT} = 5.5V$			10	nA
RESET OUTPUT (\overline{RESET})						
Reset Threshold	V_{TH}		(See Table 1)			V
V_{CC} Falling to Reset Delay	t_{RD}	V_{CC} falling at $10V/ms$		20		μs
Reset Timeout Period	t_{RP}	V_{CC} rising	145	215	285	ms
\overline{RESET} Output Low Voltage	V_{OL}	$V_{OUT} = 3.3V$, $I_{SINK} = 3.2mA$, \overline{RESET} asserted			0.3	V
		$V_{OUT} = 1.8V$, $I_{SINK} = 1mA$, \overline{RESET} asserted			0.3	
		$V_{OUT} = 1.2V$, $I_{SINK} = 100\mu A$, \overline{RESET} asserted			0.3	
\overline{RESET} Output High Voltage (Push-Pull Output)	V_{OH}	$V_{CC} \geq 1.1 \times V_{TH}$, $I_{SOURCE} = 100\mu A$, \overline{RESET} deasserted	$V_{OUT} - 0.3V$			V
\overline{RESET} Output Leakage Current (Open-Drain Output)		$V_{\overline{RESET}} = 5.5V$, reset deasserted			1	μA
POWER-FAIL COMPARATOR (PFI, \overline{PFO})						
PFI Input Threshold	V_{PFT}	V_{PFI} falling, $1.6V \leq V_{CC} \leq 5.5V$	0.570	0.590	0.611	V
PFI Input Hysteresis	$V_{PFI-HYS}$			30		mV
PFI Input Current	I_{PFI}		-1		+1	μA
\overline{PFO} Output Low Voltage		$V_{OUT} = 1.8V$, $I_{SINK} = 1mA$, \overline{PFO} asserted			0.3	V
		$V_{OUT} = 1.2V$, $I_{SINK} = 100\mu A$, \overline{PFO} asserted			0.3	
\overline{PFO} Output High Voltage (Push-Pull Output)		$I_{SOURCE} = 100\mu A$, \overline{PFO} deasserted	$V_{OUT} - 0.3V$			V
\overline{PFO} Leakage Current (Open-Drain Output)		$V_{\overline{PFO}} = 5.5V$, \overline{PFO} deasserted			1	μA
\overline{PFO} Delay Time		$(V_{PFI} + 100mV)$ to $(V_{PFI} - 100mV)$		20		μs
MANUAL RESET (\overline{MR})						
Input Low Voltage	V_{IL}		$0.3 \times V_{CC}$			V
Input High Voltage	V_{IH}		$0.7 \times V_{CC}$			
Pullup Resistance		Pullup resistance to V_{CC}	20	30		$k\Omega$
Glitch Immunity				100		ns
\overline{MR} to Reset Delay				120		ns

Battery-Backup Circuits with Regulated Output Voltage

ELECTRICAL CHARACTERISTICS (continued)

($V_{CC} = 1.53V$ to $5.5V$, $V_{BATT} = 3V$, reset not asserted, $T_A = T_J = -40^{\circ}C$ to $+85^{\circ}C$, $C_{OUT} = 10\mu F$, unless otherwise noted. Typical values are at $T_A = T_J = +25^{\circ}C$.) (Note 2)

PARAMETER	SYMBOL	CONDITIONS	MIN	TYP	MAX	UNITS
BATTERY-ON INDICATOR (BATT ON)						
Output Low Voltage	V_{OL}	$V_{OUT} = 1.2V$, $I_{SINK} = 100\mu A$, BATT ON deasserted			0.3	V
		$V_{OUT} = 1.8V$, $I_{SINK} = 1mA$, BATT ON deasserted			0.3	
		$V_{OUT} = 3.3V$, $I_{SINK} = 3.2mA$, BATT ON deasserted			0.3	
Output High Voltage (Push-Pull Output)	V_{OH}	$I_{SOURCE} = 100\mu A$, BATT ON asserted	$V_{OUT} - 0.3V$			V
Output Leakage Current (Open-Drain Output)		$V_{CC} = 5.5V$			1	μA
Output Short-Circuit Current		Sink current, $V_{CC} = 5V$ (Note 6)		60		mA
CE GATING (\overline{CEIN}, \overline{CEOUT})						
\overline{CEIN} Leakage Current		Reset asserted, $V_{CC} = 0.9 \times V_{TH}$ or 0	-1		+1	μA
\overline{CEIN} to \overline{CEOUT} Resistance		$V_{CC} = 5V$, reset deasserted		8	50	Ω
\overline{CEOUT} Short-Circuit Current		Reset asserted, $\overline{CEOUT} = 0$		0.75	2	mA
\overline{CEIN} to \overline{CEOUT} Propagation Delay		50Ω source, $C_{LOAD} = 50pF$, $V_{CC} = 4.75V$		1.5	7	ns
Output High Voltage	V_{OH}	$I_{SOURCE} = 100\mu A$, reset asserted	$V_{OUT} - 0.3V$			V
Reset to \overline{CEOUT} Delay				12		μs

Note 2: All devices are 100% production tested at $T_A = +25^{\circ}C$ and $T_A = +85^{\circ}C$. Limits over temperature are guaranteed by design.

Note 3: V_{BATT} can be 0 anytime or V_{CC} can go down to 0 if V_{BATT} is active (except at startup).

Note 4: Dropout voltage is defined as $(V_{IN} - V_{OUT})$ when V_{OUT} is 2% below the value of V_{OUT} when $V_{IN} = V_{OUT} + 1V$.

Note 5: \overline{CEIN} to \overline{CEOUT} resistance is tested with $V_{CC} = 5V$ and $V_{\overline{CEIN}} = 0$ or $5V$.

Note 6: Use external current-limiting resistor to limit current to 20mA (max).

Battery-Backup Circuits with Regulated Output Voltage

MAX16023/MAX16024

Table 1. Reset Threshold Ranges

SUFFIX	RESET THRESHOLD RANGES (V)		
	MIN	TYP	MAX
L	4.508	4.63	4.906
M	4.264	4.38	4.635
T	2.991	3.08	3.239
S	2.845	2.93	3.080
R	2.549	2.63	2.755
Z	2.243	2.32	2.425
Y	2.117	2.19	2.288
W	1.603	1.67	1.733
V	1.514	1.575	1.639

Table 2. Fixed Output Voltage

SUFFIX	NOMINAL OUTPUT VOLTAGE (V)
33	3.3
30	3.0
25	2.5
18	1.8
12	1.2

Typical Operating Characteristics

($V_{CC} = 5V$, $V_{BATT} = 0$, $I_{OUT} = 0$, $T_A = +25^\circ C$, unless otherwise noted.)

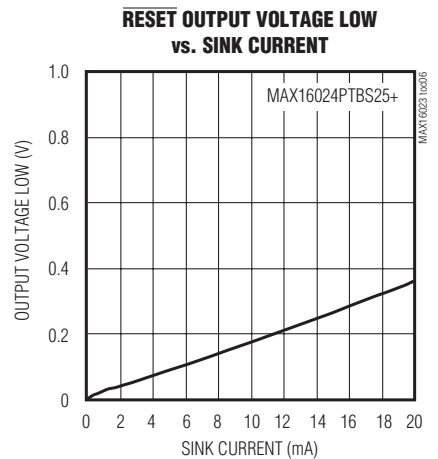
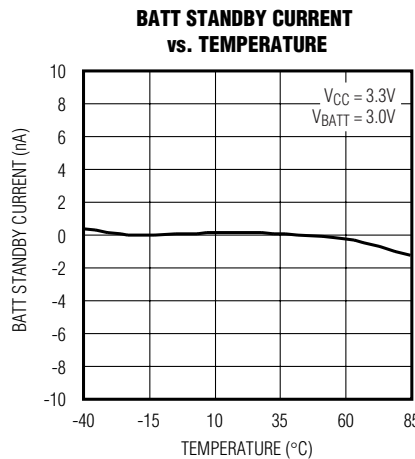
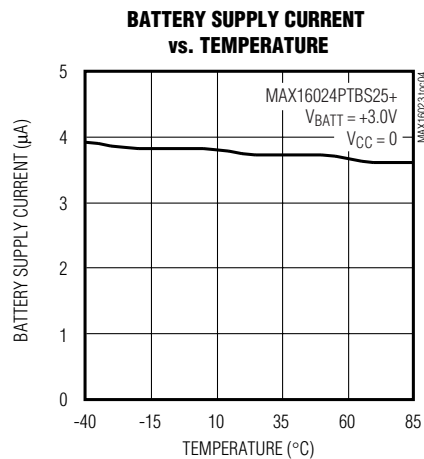
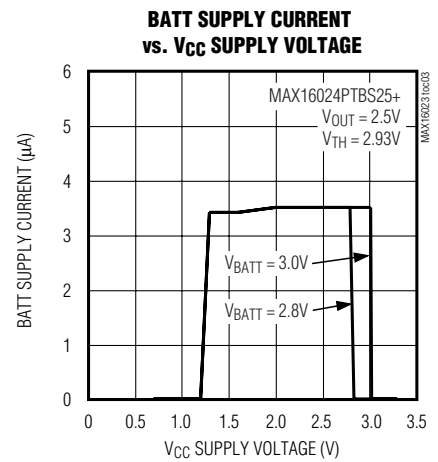
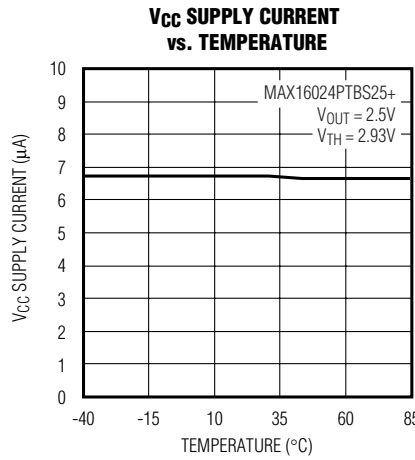
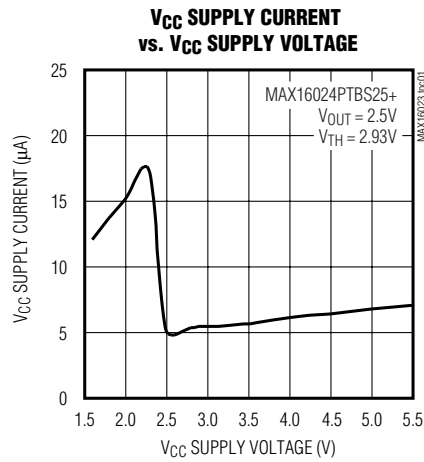

Battery-Backup Circuits with Regulated Output Voltage

Typical Operating Characteristics (continued)

($V_{CC} = 5V$, $V_{BATT} = 0$, $I_{OUT} = 0$, $T_A = +25^\circ C$, unless otherwise noted.)

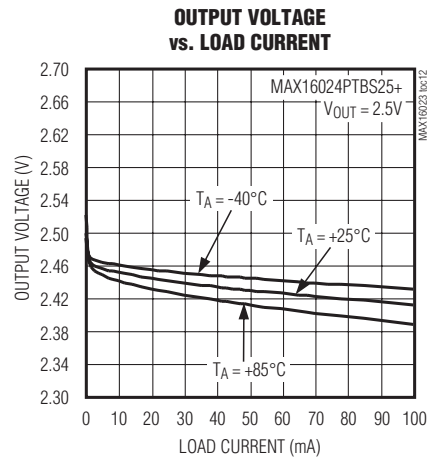
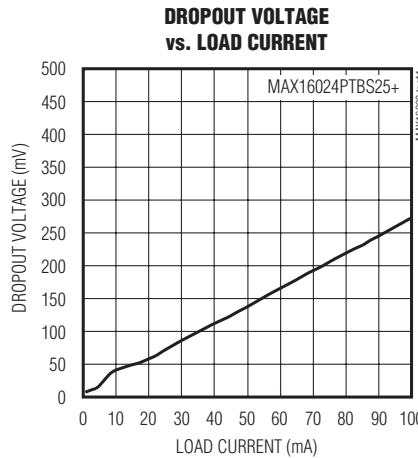
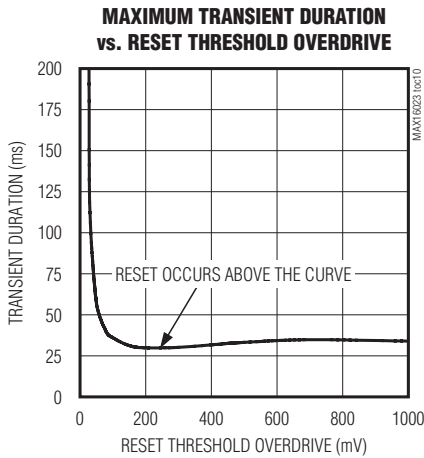
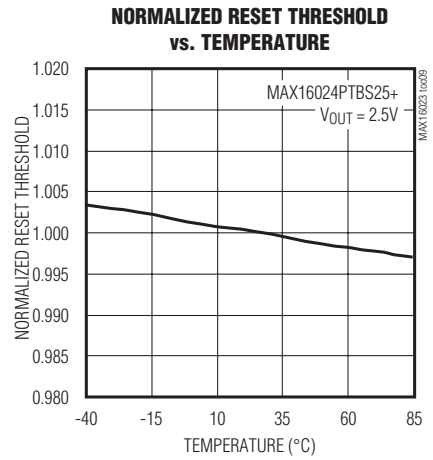
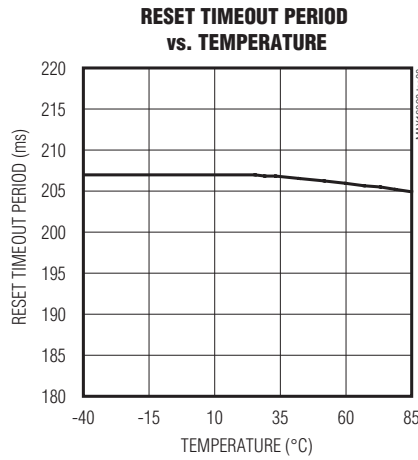
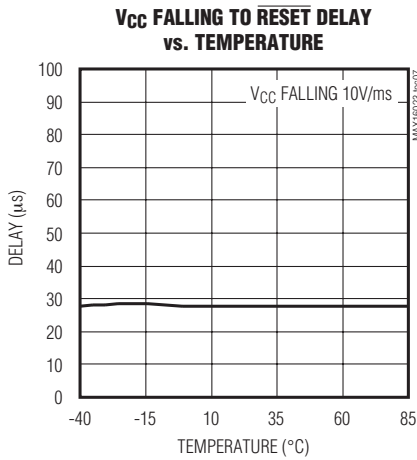

Battery-Backup Circuits with Regulated Output Voltage

Typical Operating Characteristics (continued)

($V_{CC} = 5V$, $V_{BATT} = 0$, $I_{OUT} = 0$, $T_A = +25^\circ C$, unless otherwise noted.)

MAX16023/MAX16024

OUTPUT VOLTAGE vs. V_{CC} VOLTAGE

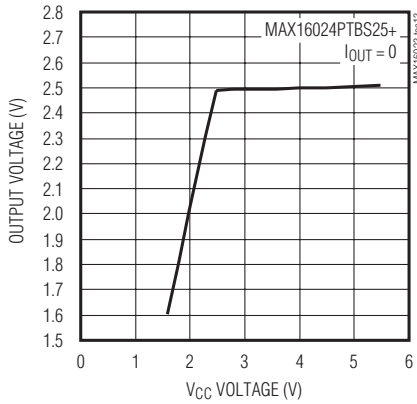

LOAD-TRANSIENT RESPONSE

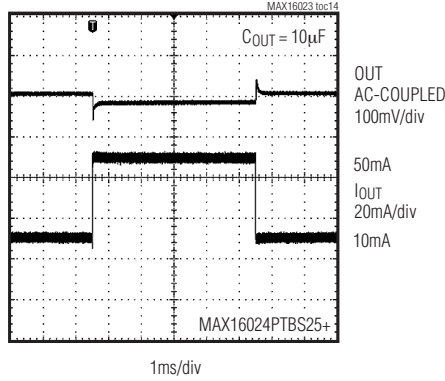

STARTUP RESPONSE

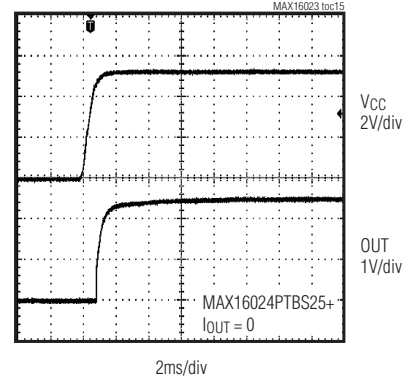

\overline{MR} FALLING TO RESET DELAY

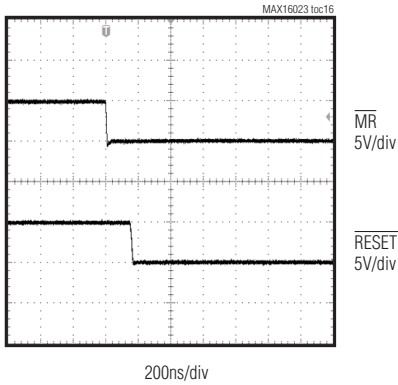

CHIP-ENABLE LOCKING OUT SIGNAL DURING RESET

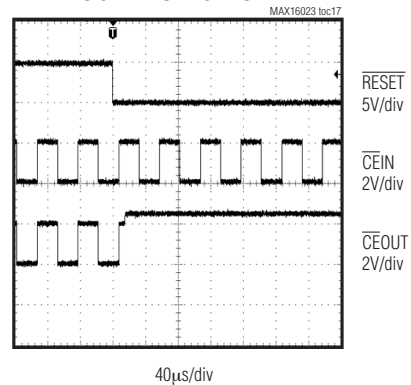

Battery-Backup Circuits with Regulated Output Voltage

Pin Description

PIN		NAME	FUNCTION
MAX16023	MAX16024		
1	2	V _{CC}	Supply Voltage Input. Bypass V _{CC} to GND with a 0.1μF capacitor.
2	3	BATT	Backup Battery Input. If V _{CC} falls below its reset threshold (V _{TH}), V _{BATT} ≥ V _{CC} , and if the regulator enters dropout, the regulator is powered from BATT. If V _{BATT} < V _{CC} , the regulator is powered from V _{CC} . Bypass BATT to GND with a 0.1μF capacitor.
3	4	$\overline{\text{MR}}$	Active-Low, Manual-Reset Input. $\overline{\text{RESET}}$ asserts when $\overline{\text{MR}}$ is pulled low. $\overline{\text{RESET}}$ remains low for the duration of reset timeout period after $\overline{\text{MR}}$ transitions from low to high. Connect $\overline{\text{MR}}$ to OUT or leave unconnected if not used. $\overline{\text{MR}}$ is internally connected to V _{CC} through a 30kΩ pullup resistor.
4	—	PFI	Power-Fail Comparator Input. Connect PFI to a resistive divider to set the desired PFI threshold. The PFI input is referenced to an internal V _{PFT} threshold. A V _{PFI-HYS} internal hysteresis provides noise immunity. The power-fail comparator is powered from OUT.
5	—	$\overline{\text{PFO}}$	Active-Low, Power-Fail Comparator Output. $\overline{\text{PFO}}$ goes low when V _{PFI} falls below the internal V _{PFT} threshold and goes high when V _{PFI} rises above V _{PFT} + V _{PFI-HYS} hysteresis.
6	7	GND	Ground
7	8	$\overline{\text{RESET}}$	Active-Low Reset Output. $\overline{\text{RESET}}$ asserts when V _{CC} falls below the reset threshold or $\overline{\text{MR}}$ is pulled low. $\overline{\text{RESET}}$ remains low for the duration of the reset timeout period after V _{CC} rises above the reset threshold and $\overline{\text{MR}}$ goes high. $\overline{\text{RESET}}$ is available in push-pull and open-drain options.
8	9	OUT	Linear Regulator Output Voltage. Available in the following factory-fixed voltages of 1.2V, 1.8V, 2.5V, 3.0V, or 3.3V for all devices. The MAX16024 is also available with an adjustable output voltage (1.8V to 5.25V). Bypass OUT to GND with a 10μF capacitor.
—	1	$\overline{\text{CEIN}}$	Chip-Enable Input. The input to CE gating circuitry. Connect to GND or OUT if not used.
—	5	SET	Set Output Voltage Input. For the fixed output voltage versions (MAX16024_TB_ _ _), SET is not used. Connect SET to GND. For MAX16024_TB_ _ _ , connect SET to an external resistive divider to set the desired output voltage between 1.8V and 5.25V.
—	6	BATT ON	Active-High, Battery-On Output. BATT ON goes high when in the battery backup mode.
—	10	$\overline{\text{CEOUT}}$	Active-Low, Chip-Enable Output. $\overline{\text{CEOUT}}$ goes low only when $\overline{\text{CEIN}}$ is low and reset is not asserted. If $\overline{\text{CEIN}}$ is low when reset is asserted, $\overline{\text{CEOUT}}$ stays low for 12μs (typ) or until $\overline{\text{CEIN}}$ goes high, whichever occurs first.
—	—	EP	Exposed Pad. Internally connected to GND. Connect EP to a large ground plane to aid heat dissipation. Do not use EP as the only ground connection for the device.

Battery-Backup Circuits with Regulated Output Voltage

Functional Diagrams

MAX16023/MAX16024

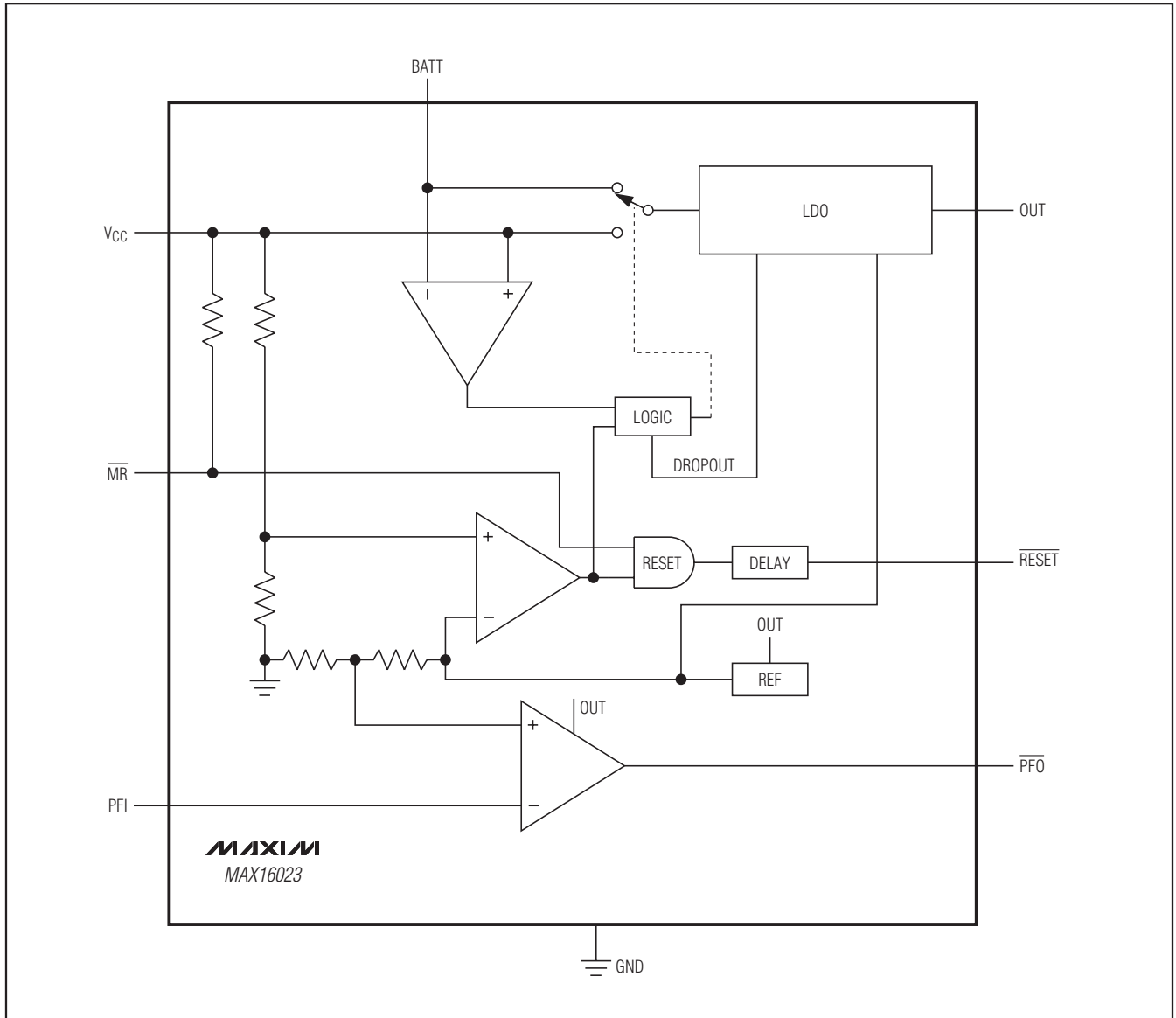

Battery-Backup Circuits with Regulated Output Voltage

Functional Diagrams (continued)

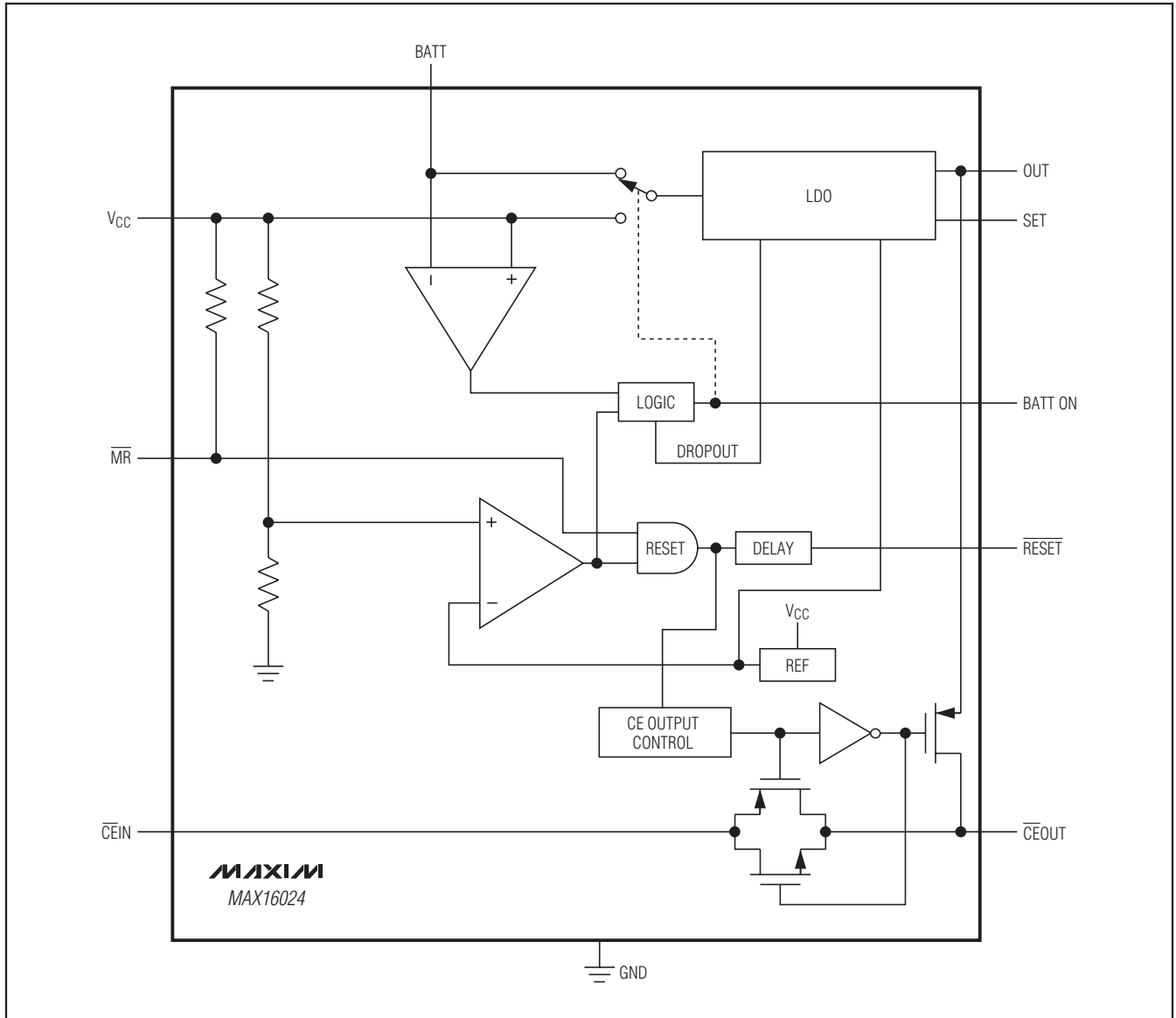

Battery-Backup Circuits with Regulated Output Voltage

Detailed Description

The *Typical Applications Circuit* shows a typical connection using the MAX16024. OUT powers the SRAM. If V_{CC} is higher than the reset threshold (V_{TH}), or if V_{CC} is lower than V_{TH} but higher than V_{BATT} , the regulator is powered from V_{CC} . If $V_{CC} < V_{TH}$, $V_{CC} < V_{BATT}$, and the regulator is in dropout, the regulator is powered from BATT (see the *Functional Diagrams*). OUT supplies up to 100mA from V_{CC} .

Backup-Battery Switchover

In a brownout or power failure, it may be necessary to preserve the contents of the RAM. With a backup-battery installed at BATT, the MAX16023/MAX16024 automatically switch the RAM to backup power when V_{CC} falls. The MAX16024 has a BATT ON output that goes high when in battery-backup mode. Three conditions must be met for these devices to switch to battery backup mode:

- 1) V_{CC} is lower than the reset threshold.
- 2) V_{CC} is lower than V_{BATT} .
- 3) The regulator is in dropout (except for the 1.2V output version).

Chip-Enable Signal Gating (MAX16024)

The MAX16024 provides internal gating of CE signals to prevent erroneous data from being written to CMOS RAM in the event of a power failure or brownout. During normal operation, the CE gate enables and passes all CE transitions. When the reset output asserts, this path becomes disabled, preventing erroneous data from corrupting the CMOS RAM and \overline{CEOUT} is pulled up to OUT through an internal current source. The 1.5ns propagation delay from \overline{CEIN} to \overline{CEOUT} allows the devices to be used with most μ Ps and high-speed DSPs.

During normal operation (reset not asserted), \overline{CEIN} is connected to \overline{CEOUT} through a low on-resistance transmission gate. If \overline{CEIN} is high when a reset asserts, \overline{CEOUT} remains high regardless of any subsequent transition on \overline{CEIN} during the reset event.

If \overline{CEIN} is low when reset asserts, \overline{CEOUT} is held low for 12 μ s to allow completion of the read/write operation. After the 12 μ s delay expires, \overline{CEOUT} goes high and stays high regardless of any subsequent transitions on \overline{CEIN} during the reset event. When \overline{CEOUT} is disconnected from \overline{CEIN} , \overline{CEOUT} is actively pulled up to OUT.

The propagation delay through the chip-enable circuitry depends on both the source impedance of the drive to \overline{CEIN} and the capacitive loading at \overline{CEOUT} . Minimize the capacitive load at \overline{CEOUT} to minimize propagation delay, and use a low-output-impedance driver.

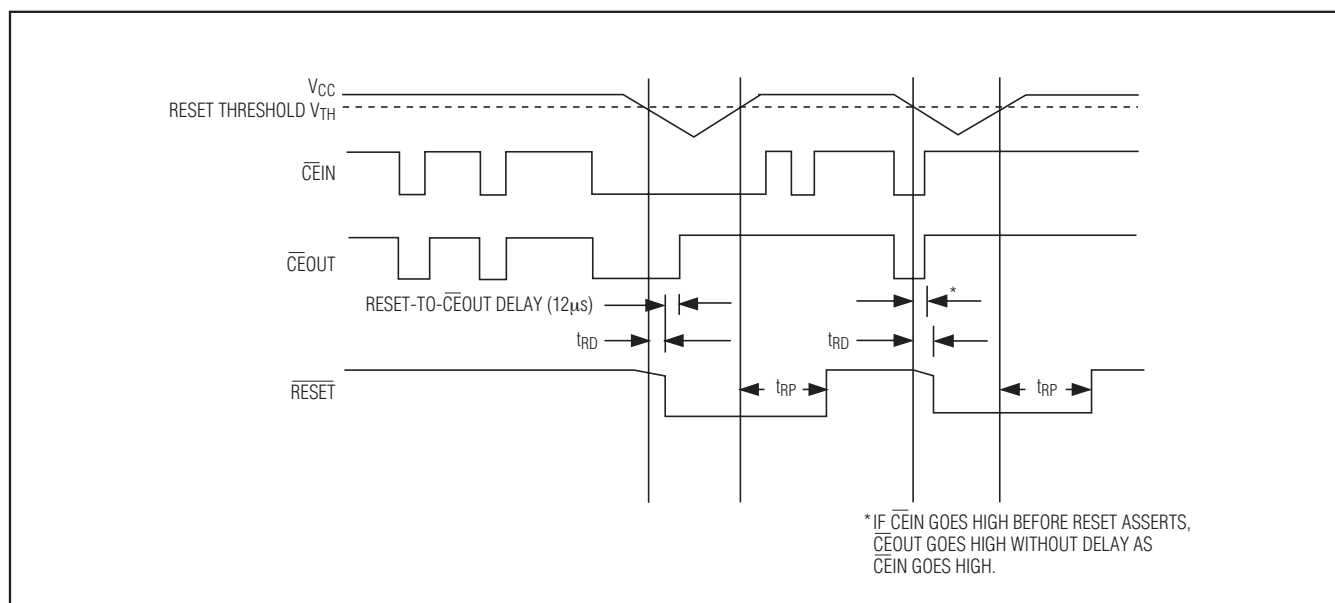

Figure 1. Reset and Chip-Enable Timing

Battery-Backup Circuits with Regulated Output Voltage

Manual-Reset Input (MAX16023/MAX16024)

Many μP -based products require manual-reset capability, allowing the operator, a test technician, or external logic circuitry to initiate a reset. For the MAX16023/MAX16024, a logic-low on $\overline{\text{MR}}$ asserts $\overline{\text{RESET}}$. $\overline{\text{RESET}}$ remains asserted while $\overline{\text{MR}}$ is low. When $\overline{\text{MR}}$ goes high, $\overline{\text{RESET}}$ deasserts after a minimum of 145ms (t_{RP}). $\overline{\text{MR}}$ has an internal 30k Ω pullup resistor to V_{CC} . $\overline{\text{MR}}$ can be driven with TTL/CMOS logic levels or with open-drain/collector outputs. Connect a normally open momentary switch from $\overline{\text{MR}}$ to GND to create a manual-reset function; external debounce circuitry is not required. If $\overline{\text{MR}}$ is driven from a long cable or the device is used in a noisy environment, connect a 0.1 μF capacitor from $\overline{\text{MR}}$ to GND to provide additional noise immunity.

Battery-On Indicator (MAX16024)

The MAX16024's BATT ON output goes high when in battery-backup mode. Use BATT ON to indicate battery-switchover status.

Battery Freshness Seal

The MAX16023/MAX16024 battery freshness seal disconnects the backup battery from internal circuitry and OUT until V_{CC} is applied. This ensures the backup battery connected to BATT is fresh when the final product is used for the first time.

The internal freshness seal latch prevents BATT from powering OUT until V_{CC} has come up for the first time, setting the latch. When V_{CC} subsequently turns off, BATT begins to power OUT.

To reenable the freshness seal (MAX16023/MAX16024):

- 1) Connect a battery to BATT.
- 2) Bring V_{CC} to 0.
- 3) Drive $\overline{\text{MR}}$ higher than $V_{\text{BATT}} + 1.2\text{V}$ for at least 3 μs .
- 4) Pull OUT to 0.

Reset Output (MAX16023/MAX16024)

A μP 's reset input starts the μP in a known state. The MAX16023/MAX16024 μP supervisory circuits assert a reset to prevent code-execution errors during power-up, power-down, and brownout conditions. $\overline{\text{RESET}}$ asserts when V_{CC} is below the reset threshold and remains low for at least 145ms (t_{RP}) after V_{CC} rises

above the reset threshold. $\overline{\text{RESET}}$ also asserts when $\overline{\text{MR}}$ is low. $\overline{\text{RESET}}$ is available in both push-pull and open-drain configurations.

Power-Fail Comparator (MAX16023)

The MAX16023 offers an additional undervoltage comparator. The output $\overline{\text{PFO}}$ goes low when the voltage at PFI falls below its V_{PFT} threshold. Common uses for the power-fail comparator include monitoring the input of the power supply (such as a battery) before any voltage regulation to provide an early power-fail warning, so software can conduct an orderly system shutdown. The power-fail comparator has a typical input hysteresis of $V_{\text{PFI-HYS}}$ and is powered from OUT, making it independent of the reset circuit. Connect PFI to GND, if not used.

Regulator Output

Fixed output voltages of 1.2V, 1.8V, 2.5V, 3.0V, and 3.3V are available for all devices. The regulator output delivers up to 100mA of load current.

The MAX16024 is available with both fixed and adjustable output-voltage options. Use an external resistive divider network connected between OUT, SET, and GND (Figure 2) to set the adjustable output voltage from 1.8V to 5.25V. Connect SET to GND for parts with fixed output voltage option.

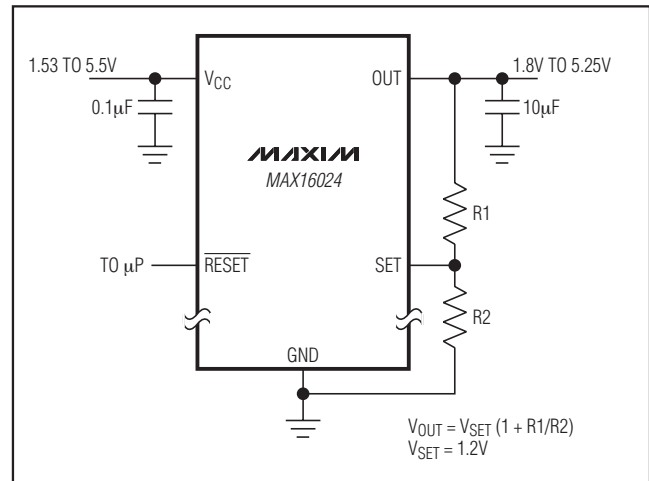

Figure 2. Setting the Adjustable Output Voltage (MAX16024 Only)

Battery-Backup Circuits with Regulated Output Voltage

Applications Information

The MAX16023/MAX16024 are protected for typical short-circuit conditions of 10s or less. Shorting OUT to ground for longer than 10s might damage the device. Bypass V_{CC} and BATT to GND with a 0.1μF capacitor each. Connect a 10μF low-ESR capacitor from OUT to GND. All capacitors should be mounted as close as possible to the device.

Monitoring an Additional Supply

The MAX16023 power-fail comparator can monitor either positive or negative supplies using a resistive divider to PFI (Figures 3 and 4). PFO can be used to generate an interrupt to the μP or to trigger a reset. To monitor a negative supply, connect the top of the resistive divider to V_{CC}. Connect the bottom of the resistive divider to the negative voltage to be monitored.

Adding Hysteresis to PFI

The power-fail comparators have a typical input hysteresis of V_{PFI-HYS}. This is sufficient for most applications where a power-supply line is being monitored through an external voltage-divider (see the *Monitoring an Additional Supply* section). Figure 5 shows how to add hysteresis to the power-fail comparator. Select the ratio of R1 and R2 such that PFI sees V_{PFT} when V_{IN} falls to the desired trip point (V_{TRIP}). Resistor R3 adds hysteresis. R3 is typically an order of magnitude greater than R1 or R2. The current through R1 and R2 should be at least 100μA to ensure that the 1μA (max) PFI input current does not shift the trip point. R3 should be larger than 50kΩ to prevent it from loading down PFO. Capacitor C1 adds additional noise rejection.

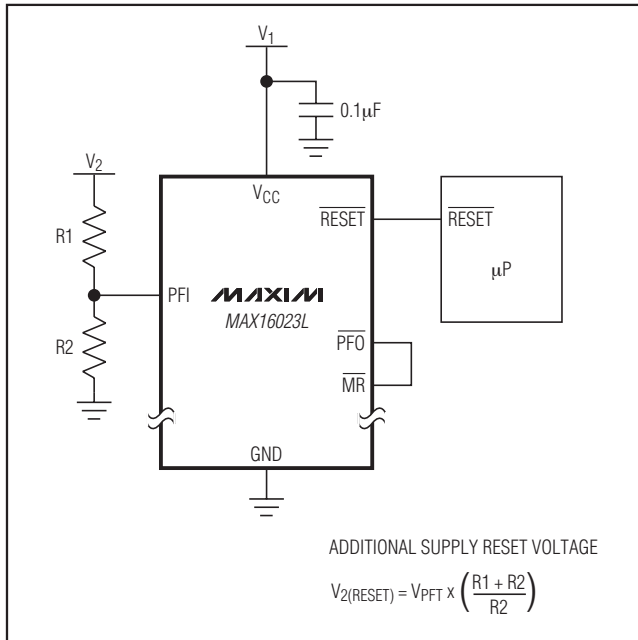

Figure 3. Monitoring an Additional Supply by Connecting PFO to MR

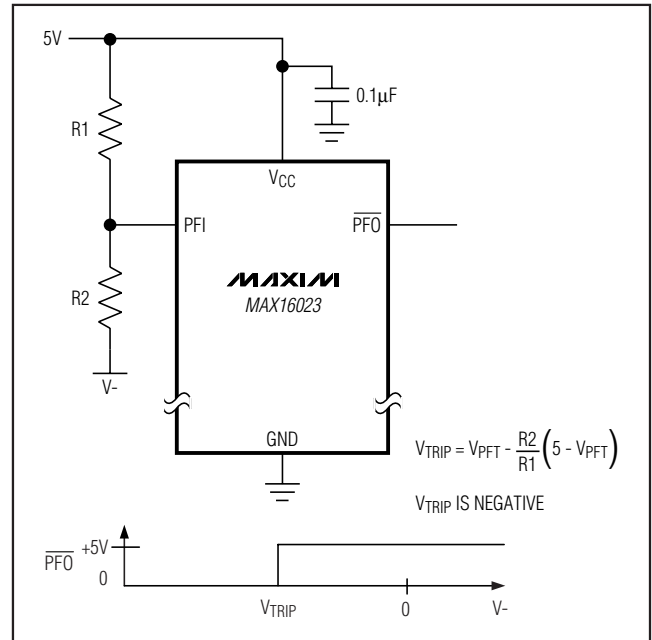

Figure 4. Monitoring a Negative Supply

Battery-Backup Circuits with Regulated Output Voltage

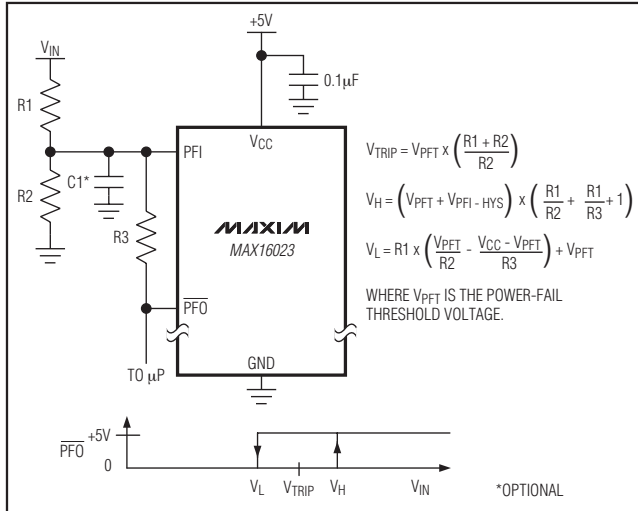

Figure 5. Adding Hysteresis to the Power-Fail Comparator

Operation Without a Backup Power Source

The MAX16023/MAX16024 provide battery-backup functions. If a backup power source is not used, connect BATT to GND.

Replacing the Backup Battery

When V_{CC} is above V_{TH} , the backup power source can be removed without danger of triggering a reset pulse. The device does not enter battery-backup mode when V_{CC} stays above the reset threshold voltage.

Negative-Going V_{CC} Transients

The MAX16023/MAX16024 are relatively immune to short duration, negative-going V_{CC} transients. Resetting the μP when V_{CC} experiences only small glitches is usually not desirable. A 0.1 μF bypass capacitor mounted close to the V_{CC} pin provides additional transient immunity.

Capacitor Selection and Regulator Stability

For stable operation, connect a low-ESR 10 μF (min) output capacitor from OUT to GND. To reduce noise and improve load-transient response and power-supply rejection, use larger output capacitor values.

Part Number Table

PART	OUTPUT TYPE	RESET THRESHOLD VOLTAGE (V)	REGULATED OUTPUT VOLTAGE (V)	PART	OUTPUT TYPE	RESET THRESHOLD VOLTAGE (V)	REGULATED OUTPUT VOLTAGE (V)
MAX16023LTAL12+T	Push-Pull	4.63	1.2	MAX16024LTBL12+T	Push-Pull	4.63	1.2
MAX16023LTAL18+T	Push-Pull	4.63	1.8	MAX16024LTBL18+T	Push-Pull	4.63	1.8
MAX16023LTAL25+T	Push-Pull	4.63	2.5	MAX16024LTBL25+T	Push-Pull	4.63	2.5
MAX16023LTAL33+T	Push-Pull	4.63	3.3	MAX16024LTBL33+T	Push-Pull	4.63	3.3
MAX16023LTAM12+T	Push-Pull	4.38	1.2	MAX16024LTBM12+T	Push-Pull	4.38	1.2
MAX16023LTAM18+T	Push-Pull	4.38	1.8	MAX16024LTBM18+T	Push-Pull	4.38	1.8
MAX16023LTAM25+T	Push-Pull	4.38	2.5	MAX16024LTBM25+T	Push-Pull	4.38	2.5
MAX16023LTAM33+T	Push-Pull	4.38	3.3	MAX16024LTBM33+T	Push-Pull	4.38	3.3
MAX16023LTAT12+T	Push-Pull	3.08	1.2	MAX16024LTBT12+T	Push-Pull	3.08	1.2
MAX16023LTAT18+T	Push-Pull	3.08	1.8	MAX16024LTBT18+T	Push-Pull	3.08	1.8
MAX16023LTAT25+T	Push-Pull	3.08	2.5	MAX16024LTBT25+T	Push-Pull	3.08	2.5
MAX16023LTAS12+T	Push-Pull	2.93	1.2	MAX16024LTBS12+T	Push-Pull	2.93	1.2
MAX16023LTAS18+T	Push-Pull	2.93	1.8	MAX16024LTBS18+T	Push-Pull	2.93	1.8
MAX16023LTAS25+T	Push-Pull	2.93	2.5	MAX16024LTBS25+T	Push-Pull	2.93	2.5
MAX16023LTAR12+T	Push-Pull	2.63	1.2	MAX16024LTBR12+T	Push-Pull	2.63	1.2
MAX16023LTAR18+T	Push-Pull	2.63	1.8	MAX16024LTBR18+T	Push-Pull	2.63	1.8
MAX16023LTAR25+T	Push-Pull	2.63	2.5	MAX16024LTBR25+T	Push-Pull	2.63	2.5
MAX16023LTAZ12+T	Push-Pull	2.32	1.2	MAX16024LTBZ12+T	Push-Pull	2.32	1.2

Battery-Backup Circuits with Regulated Output Voltage

Part Number Table (continued)

PART	OUTPUT TYPE	RESET THRESHOLD VOLTAGE (V)	REGULATED OUTPUT VOLTAGE (V)	PART	OUTPUT TYPE	RESET THRESHOLD VOLTAGE (V)	REGULATED OUTPUT VOLTAGE (V)
MAX16023LTAZ18+T	Push-Pull	2.32	1.8	MAX16024LTBZ18+T	Push-Pull	2.32	1.8
MAX16023LTAY12+T	Push-Pull	2.19	1.2	MAX16024LTBY12+T	Push-Pull	2.19	1.2
MAX16023LTAY18+T	Push-Pull	2.19	1.8	MAX16024LTBY18+T	Push-Pull	2.19	1.8
MAX16023LTAW12+T	Push-Pull	1.67	1.2	MAX16024LTBW12+T	Push-Pull	1.67	1.2
MAX16023LTAV12+T	Push-Pull	1.575	1.2	MAX16024LTBV12+T	Push-Pull	1.575	1.2
MAX16023PTAL12+T	Open-Drain	4.63	1.2	MAX16024PTBL12+T	Open-Drain	4.63	1.2
MAX16023PTAL18+T	Open-Drain	4.63	1.8	MAX16024PTBL18+T	Open-Drain	4.63	1.8
MAX16023PTAL25+T	Open-Drain	4.63	2.5	MAX16024PTBL25+T	Open-Drain	4.63	2.5
MAX16023PTAL33+T	Open-Drain	4.63	3.3	MAX16024PTBL33+T	Open-Drain	4.63	3.3
MAX16023PTAM12+T	Open-Drain	4.38	1.2	MAX16024PTBM12+T	Open-Drain	4.38	1.2
MAX16023PTAM18+T	Open-Drain	4.38	1.8	MAX16024PTBM18+T	Open-Drain	4.38	1.8
MAX16023PTAM25+T	Open-Drain	4.38	2.5	MAX16024PTBM25+T	Open-Drain	4.38	2.5
MAX16023PTAM33+T	Open-Drain	4.38	3.3	MAX16024PTBM33+T	Open-Drain	4.38	3.3
MAX16023PTAT12+T	Open-Drain	3.08	1.2	MAX16024PTBS12+T	Open-Drain	3.08	1.2
MAX16023PTAT18+T	Open-Drain	3.08	1.8	MAX16024PTBS18+T	Open-Drain	3.08	1.8
MAX16023PTAT25+T	Open-Drain	3.08	2.5	MAX16024PTBS25+T	Open-Drain	3.08	2.5
MAX16023PTAS12+T	Open-Drain	2.93	1.2	MAX16024PTBT12+T	Open-Drain	2.93	1.2
MAX16023PTAS18+T	Open-Drain	2.93	1.8	MAX16024PTBT18+T	Open-Drain	2.93	1.8
MAX16023PTAS25+T	Open-Drain	2.93	2.5	MAX16024PTBT25+T	Open-Drain	2.93	2.5
MAX16023PTAR12+T	Open-Drain	2.63	1.2	MAX16024PTBR12+T	Open-Drain	2.63	1.2
MAX16023PTAR18+T	Open-Drain	2.63	1.8	MAX16024PTBR18+T	Open-Drain	2.63	1.8
MAX16023PTAR25+T	Open-Drain	2.63	2.5	MAX16024PTBR25+T	Open-Drain	2.63	2.5
MAX16023PTAZ12+T	Open-Drain	2.32	1.2	MAX16024PTBZ12+T	Open-Drain	2.32	1.2
MAX16023PTAZ18+T	Open-Drain	2.32	1.8	MAX16024PTBZ18+T	Open-Drain	2.32	1.8
MAX16023PTAY12+T	Open-Drain	2.19	1.2	MAX16024PTBY12+T	Open-Drain	2.19	1.2
MAX16023PTAY18+T	Open-Drain	2.19	1.8	MAX16024PTBY18+T	Open-Drain	2.19	1.8
MAX16023PTAW12+T	Open-Drain	1.67	1.2	MAX16024PTBW12+T	Open-Drain	1.67	1.2
MAX16023PTAV12+T	Open-Drain	1.575	1.2	MAX16024PTBV12+T	Open-Drain	1.575	1.2
MAX16024PTBL+T	Open-Drain	4.63	Adjustable	MAX16024LTBL+T	Push-Pull	4.63	Adjustable
MAX16024PTBM+T	Open-Drain	4.38	Adjustable	MAX16024LTBM+T	Push-Pull	4.38	Adjustable
MAX16024PTBT+T	Open-Drain	3.08	Adjustable	MAX16024LTBT+T	Push-Pull	3.08	Adjustable
MAX16024PTBS+T	Open-Drain	2.93	Adjustable	MAX16024LTBS+T	Push-Pull	2.93	Adjustable
MAX16024PTBR+T	Open-Drain	2.63	Adjustable	MAX16024LTBR+T	Push-Pull	2.63	Adjustable
MAX16024PTBZ+T	Open-Drain	2.32	Adjustable	MAX16024LTBZ+T	Push-Pull	2.32	Adjustable
MAX16024PTBY+T	Open-Drain	2.19	Adjustable	MAX16024LTBY+T	Push-Pull	2.19	Adjustable
MAX16024PTBW+T	Open-Drain	1.67	Adjustable	MAX16024LTBW+T	Push-Pull	1.67	Adjustable
MAX16024PTBV+T	Open-Drain	1.575	Adjustable	MAX16024LTBV+T	Push-Pull	1.575	Adjustable

Bold parts denote standard versions. Samples are generally available on standard versions.

Contact factory for availability of nonstandard versions.

MAX16023/MAX16024

Battery-Backup Circuits with Regulated Output Voltage

Selector Guide

PART	OUTPUTS (RESET, PFO, BATT ON)	RESET	MR	POWER-FAIL COMPARATOR	CE GATE	BATT ON	REGULATOR OUTPUT VOLTAGE
MAX16023L	Push-Pull	√	√	√	—	—	Fixed
MAX16023P	Open Drain	√	√	√	—	—	Fixed
MAX16024L	Push-Pull	√	√	—	√	√	Fixed/adjustable
MAX16024P	Open Drain	√	√	—	√	√	Fixed/adjustable

Typical Applications Circuit

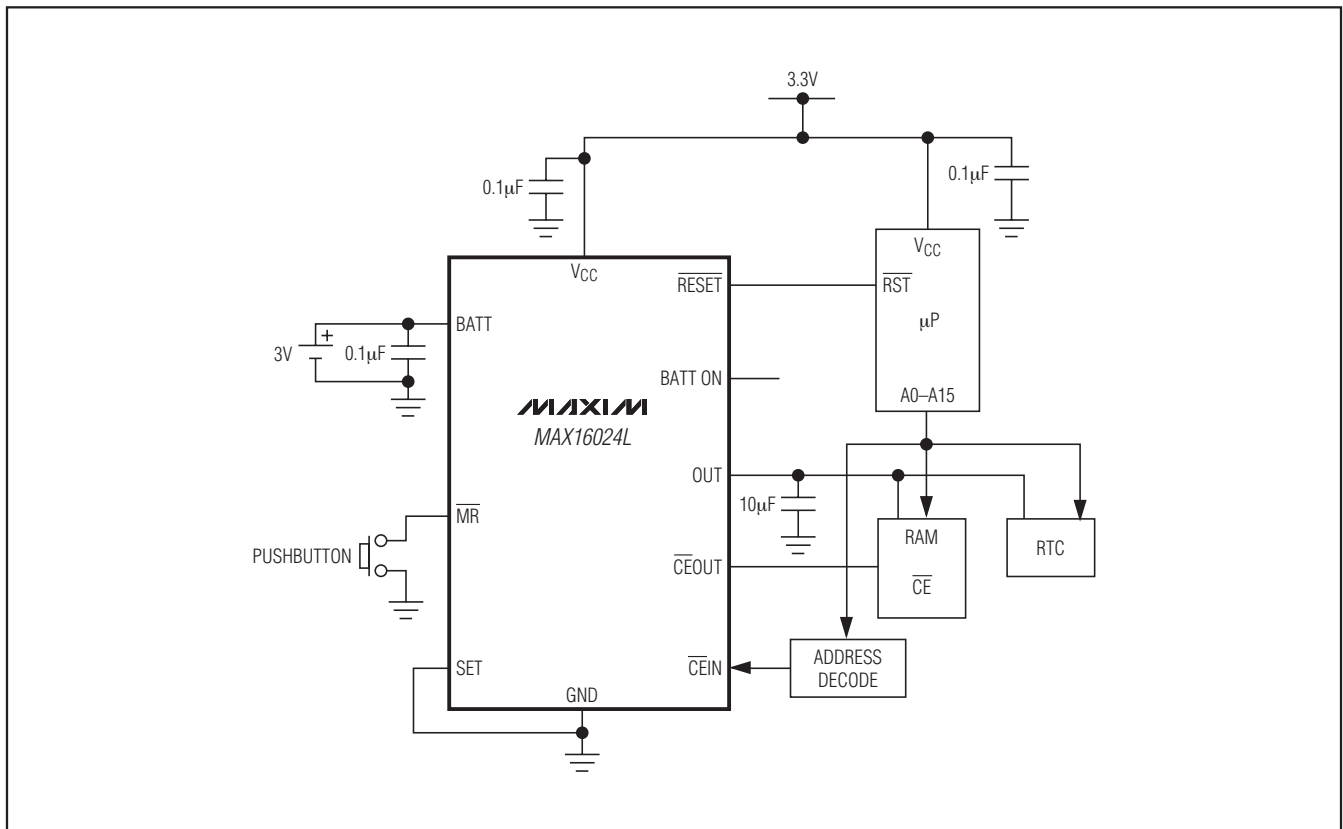

Battery-Backup Circuits with Regulated Output Voltage

Chip Information

PROCESS: BiCMOS

Package Information

For the latest package outline information and land patterns, go to www.maxim-ic.com/packages.

PACKAGE TYPE	PACKAGE CODE	DOCUMENT NO.
8 TDFN	T833-2	21-0137
10 TDFN	T1033-1	21-0137

MAX16023/MAX16024

Maxim cannot assume responsibility for use of any circuitry other than circuitry entirely embodied in a Maxim product. No circuit patent licenses are implied. Maxim reserves the right to change the circuitry and specifications without notice at any time.

Maxim Integrated Products, 120 San Gabriel Drive, Sunnyvale, CA 94086 408-737-7600 _____ 17

Looking for pricing, stock, or lifecycle information?

Click below to explore more details on WIN SOURCE:

 [View MAX16024LTBS+ on WIN SOURCE](#)

 [Maxim Integrated](#) Information

Optimize Your Supply Chain with WIN SOURCE Solutions

-  Global Sourcing Solution
-  Obsolete Management
-  Cost Control Management
-  Shortage Management
-  Alternative Solution
-  Excess Inventory Management