



**THE DATASHEET OF  
MAX1501ETE+**



# Highly Integrated, Linear Battery Charger with Thermal Regulation for Portable Applications

## General Description

The MAX1501 intelligent, constant-current, constant-voltage (CCCV), temperature-regulated battery charger charges a single lithium-ion (Li+) cell or three-cell NiMH/NiCd batteries. The device integrates the current-sense resistor, PMOS pass element, and thermal-regulation circuitry, while eliminating the reverse-blocking Schottky diode to create the simplest charging solution for hand-held equipment.

For single-cell Li+ batteries, the MAX1501 functions as a stand-alone charger to control the charging sequence from the prequalification state through fast charge, top-off, and charge termination. With 3-cell NiMH/NiCd batteries, the MAX1501 requires collaboration with a microcontroller to determine the best charging algorithm. Proprietary thermal-regulation circuitry limits the die temperature when fast charging or while exposed to high ambient temperatures, allowing maximum charging current without damaging the charger. The MAX1501 continually supplies a regulated output voltage under no-battery conditions, allowing battery changing without interrupting system power.

The device achieves high flexibility by providing an adjustable fast-charge current, top-off current, safety timer (disabled in the MAX1501Z), and thermal-regulation setpoint. Other features include input power detection ( $\overline{ACOK}$ ) and input under-/overvoltage protection. The MAX1501 provides active-low control inputs.

The MAX1501 accepts a 4.5V to 13V supply, but disables charging when the input voltage exceeds 6.5V, preventing excessive power dissipation. The MAX1501 operates over the extended temperature range (-40°C to +85°C) and is available in a compact 16-pin thermally enhanced 5mm x 5mm thin QFN package with 0.8mm profile.

## Applications

- Cellular and Cordless Phones
- PDAs
- Digital Cameras and MP3 Players
- USB Appliances
- Charging Cradles and Docks
- Bluetooth™ Equipment

*Pin Configuration appears at end of data sheet.*

*Bluetooth is a trademark of Ericsson.*

## Features

- ◆ Stand-Alone 1-Cell Li+ Charging, Microprocessor-Controlled 3-Cell NiMH/NiCd Charging
- ◆ No FET, Reverse-Blocking Diode, or Current-Sense Resistor Required
- ◆ 1.4A (max) Programmable Fast-Charge Current
- ◆ +95°C, +115°C, and +135°C Proprietary Programmable Die Temperature Regulation Control
- ◆ 4.5V to 13V Input Voltage Range with Input Overvoltage (OVLO) Protection Above 6.5V
- ◆ Programmable Top-Off Current Threshold: 10%, 20%, or 30% of the Fast-Charge Current
- ◆ Charge-Current Monitor for Fuel Gauging
- ◆ Programmable Safety Timer (3, 4.5, or 6 hours)
- ◆ Input Power Detection Output ( $\overline{ACOK}$ ) and Charge Enable Input (CHGEN)
- ◆ Automatic Recharge
- ◆ Digital Soft-Start Limits Inrush Current
- ◆ Charge Status Outputs for LEDs or  $\mu$ P Interface

## Ordering Information

PART	TEMP RANGE	PIN-PACKAGE
MAX1501ETE	-40°C to +85°C	16 Thin QFN
MAX1501ZETE	-40°C to +85°C	16 Thin QFN

## Typical Operating Circuit

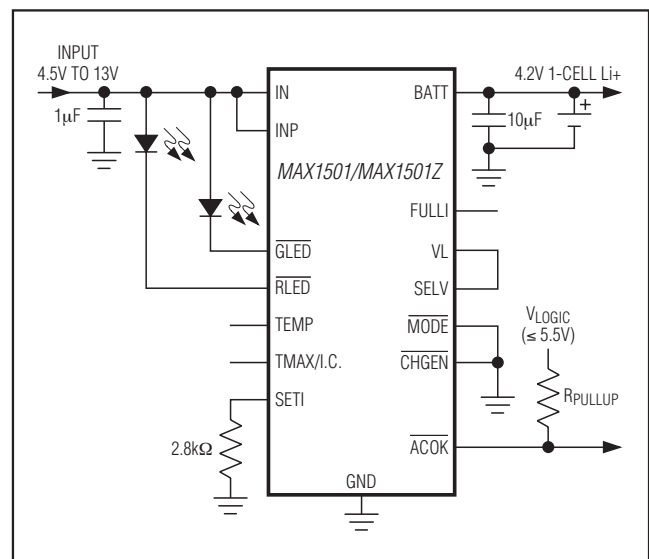

**For pricing, delivery, and ordering information, please contact Maxim Direct at 1-888-629-4642, or visit Maxim's website at [www.maximintegrated.com](http://www.maximintegrated.com).**

# MAX1501

## Highly Integrated, Linear Battery Charger with Thermal Regulation for Portable Applications

### ABSOLUTE MAXIMUM RATINGS

IN, INP, $\overline{\text{RLED}}$ , $\overline{\text{GLED}}$ to GND	-0.3V to +14V
IN to INP	-0.3V to +0.3V
VL, BATT, SET1, $\overline{\text{ACOK}}$ , $\overline{\text{MODE}}$ , $\overline{\text{CHGEN}}$ , SELV, FULL1, TMAX/I.C., TEMP to GND	-0.3V to +6V
VL to IN	-14V to +0.3V

Continuous Power Dissipation ( $T_A = +70^\circ\text{C}$ ) 16-Pin 5mm x 5mm Thin QFN (derate 21.3mW/ $^\circ\text{C}$ above $+70^\circ\text{C}$ )	1702mW
Operating Temperature Range	-40 $^\circ\text{C}$ to +85 $^\circ\text{C}$
Junction Temperature	+150 $^\circ\text{C}$
Storage Temperature Range	-65 $^\circ\text{C}$ to +150 $^\circ\text{C}$
Lead Temperature (soldering, 10s)	+300 $^\circ\text{C}$

Stresses beyond those listed under "Absolute Maximum Ratings" may cause permanent damage to the device. These are stress ratings only, and functional operation of the device at these or any other conditions beyond those indicated in the operational sections of the specifications is not implied. Exposure to absolute maximum rating conditions for extended periods may affect device reliability.

### ELECTRICAL CHARACTERISTICS

( $V_{\text{IN}} = V_{\text{INP}} = 5\text{V}$ ,  $V_{\text{BATT}} = 3.5\text{V}$ ,  $\overline{\text{ACOK}} = \overline{\text{GLED}} = \overline{\text{RLED}} = \text{TEMP} = \text{TMAX/I.C.} = \text{FULL1} = \text{open}$ ,  $\overline{\text{CHGEN}} = \overline{\text{MODE}} = \text{GND}$ ,  $R_{\text{SET1}} = 2.8\text{k}\Omega$ ,  $C_{\text{IN}} = 1\mu\text{F}$ ,  $C_{\text{BATT}} = 10\mu\text{F}$ ,  $T_A = 0^\circ\text{C}$  to  $+85^\circ\text{C}$ , unless otherwise noted. Typical values are at  $T_A = +25^\circ\text{C}$ .)

PARAMETER	CONDITIONS	MIN	TYP	MAX	UNITS	
IN, INP Input Voltage		0		13	V	
IN, INP Input Operating Range		4.50		6.25	V	
VL Output Voltage	$4.5\text{V} \leq V_{\text{IN}} \leq 6.25\text{V}$ , $I_{\text{VL}} < 250\mu\text{A}$	2.7	3	3.3	V	
$\overline{\text{ACOK}}$ Trip Point	$V_{\text{IN}} - V_{\text{BATT}}$ , rising	40	70	100	mV	
	$V_{\text{IN}} - V_{\text{BATT}}$ , falling	30	55	85		
	$V_{\text{IN}} - V_{\text{BATT}}$ , hysteresis		15			
$\overline{\text{ACOK}}$ Sink Current	$4.5\text{V} \leq V_{\text{IN}} \leq 6.25\text{V}$ , $V_{\overline{\text{ACOK}}} = 0.6\text{V}$	75			$\mu\text{A}$	
Undervoltage Lockout Trip Point	$V_{\text{IN}}$ rising	4.05	4.125	4.20	V	
	$V_{\text{IN}}$ falling	3.9	4.025	4.1		
	Hysteresis		100		mV	
Overvoltage Lockout Trip Point	$V_{\text{IN}}$ rising	6.25	6.50	6.75	V	
IN Input Current	Li+, NiMH/NiCd, and no-battery modes		5	8	mA	
	Disable mode		1.5	3		
	Off mode ( $V_{\text{IN}} = 4\text{V}$ )			0.25		
BATT Input Current	$V_{\text{BATT}} = 4.3\text{V}$		45	80	$\mu\text{A}$	
	$V_{\text{IN}} = 0$		3	10		
	Disable mode		2	6		
Leakage into Battery	$V_{\text{IN}} = V_{\text{INP}} = 13\text{V}$ , $V_{\text{BATT}} = 0$			5	$\mu\text{A}$	
RMS Charge Current				1.4	A	
Battery Regulation Voltage	Li+ mode	SELV = VL	4.166	4.2	4.234	V
		SELV = GND	4.067	4.1	4.133	
	NiMH/NiCd mode	SELV = VL, $V_{\text{IN}} = V_{\text{INP}} = 6\text{V}$	4.85	4.95	5.05	
		SELV = GND	4.4	4.5	4.6	
Output Regulation Voltage	No-battery mode	3.700	4.0	4.234	V	
BATT Precharge Threshold Voltage	BATT rising	2.675	2.8	2.925	V	
Fast-Charge Current-Loop System Accuracy	$R_{\text{SET1}} = 2.8\text{k}\Omega$	460	500	540	mA	
	$R_{\text{SET1}} = 1.75\text{k}\Omega$	736	800	864		

# MAX1501

## Highly Integrated, Linear Battery Charger with Thermal Regulation for Portable Applications

### ELECTRICAL CHARACTERISTICS (continued)

( $V_{IN} = V_{INP} = 5V$ ,  $V_{BATT} = 3.5V$ ,  $\overline{ACOK} = \overline{GLED} = \overline{RLED} = TEMP = TMAX/I.C. = FULLI = open$ ,  $\overline{CHGEN} = \overline{MODE} = GND$ ,  $R_{SET1} = 2.8k\Omega$ ,  $C_{IN} = 1\mu F$ ,  $C_{BATT} = 10\mu F$ ,  $T_A = 0^\circ C$  to  $+85^\circ C$ , unless otherwise noted. Typical values are at  $T_A = +25^\circ C$ .)

PARAMETER	CONDITIONS	MIN	TYP	MAX	UNITS	
Precharge Current System Accuracy	% of fast-charge current, $V_{BATT} = 2V$	5	10	15	%	
Die Temperature Regulation Setpoint (Note 1)	TEMP = GND		95		°C	
	TEMP = open		115			
	TEMP = VL		135			
Current-Sense Amplifier Gain	$I_{BATT}$ to $I_{SET1}$ , precharge mode, $V_{BATT} = 2V$	0.70	1	1.30	mA/A	
	$I_{BATT}$ to $I_{SET1}$ , fast-charge mode	0.95	1	1.05		
Internal Current-Sense Resistance			84		mΩ	
Regulator Dropout Voltage	$V_{IN} - V_{BATT}$ , NiMH/NiCd mode, $V_{BATT} = 4.3V$ , $I_{BATT} = 425mA$		190	350	mV	
Logic Input Low Voltage	$\overline{CHGEN}$ , $\overline{MODE}$ , $4.5V \leq V_{IN} \leq 6.25V$			0.52	V	
Logic Input High Voltage	$\overline{CHGEN}$ , $\overline{MODE}$ , $4.5V \leq V_{IN} \leq 6.25V$	1.25			V	
Internal Pulldown Resistance	$\overline{CHGEN}$ , $\overline{MODE}$	100	175	400	kΩ	
Internal Pullup Resistance	SELV	100	175	400	kΩ	
Internal Bias Resistance	FULLI, TEMP, TMAX	50	90	200	kΩ	
Internal Bias Voltage	FULLI, TEMP, TMAX		$V_{VL}/2$		V	
$\overline{RLED}$ Output Low Current	$V_{\overline{RLED}} = 1V$	7	10	18	mA	
$\overline{GLED}$ Output Low Current	$V_{\overline{GLED}} = 1V$	14	20	34	mA	
$\overline{GLED}$ , $\overline{RLED}$ Output High Leakage Current	$V_{\overline{GLED}} = V_{\overline{RLED}} = V_{IN} = V_{INP} = 13V$		0.1	1	μA	
Full-Battery Detection Current Threshold	% of fast-charge current	FULLI = GND	5	10	15	%
		FULLI = VL	15	20	25	
		FULLI = open	25	30	35	
$V_{BATT}$ Restart Threshold	Li+ mode	SELV = VL	3.9	4.0	4.1	V
		SELV = GND	3.8	3.9	4.0	
	NiMH/NiCd mode	3.9	4.0	4.1		
Charge-Timer Accuracy		-10		+10	%	
Charge-Timer Duration (MAX1501 Only)	TMAX = GND		3		hrs	
	TMAX = open		4.5			
	TMAX = VL		6			

# MAX1501

## Highly Integrated, Linear Battery Charger with Thermal Regulation for Portable Applications

### ELECTRICAL CHARACTERISTICS

( $V_{IN} = V_{INP} = 5V$ ,  $V_{BATT} = 3.5V$ ,  $\overline{ACOK} = \overline{GLED} = \overline{ILED} = TEMP = TMAX/I.C. = FULLI = open$ ,  $\overline{CHGEN} = \overline{MODE} = GND$ ,  $R_{SET1} = 2.8k\Omega$ ,  $C_{IN} = 1\mu F$ ,  $C_{BATT} = 10\mu F$ ,  $T_A = -40^\circ C$  to  $+85^\circ C$ , unless otherwise noted. Typical values are at  $T_A = +25^\circ C$ .) (Note 2)

PARAMETER	CONDITIONS	MIN	TYP	MAX	UNITS
IN, INP Input Voltage		0		13	V
IN, INP Input Operating Range		4.50		6.25	V
VL Output Voltage	$4.5V \leq V_{IN} \leq 6.25V$ , $I_{VL} < 250\mu A$	2.7		3.3	V
$\overline{ACOK}$ Trip Point	$V_{IN} - V_{BATT}$ , rising	40		100	mV
	$V_{IN} - V_{BATT}$ , falling	30		85	
$\overline{ACOK}$ Sink Current	$4.5V \leq V_{IN} \leq 6.25V$ , $V_{\overline{ACOK}} = 0.6V$	75			$\mu A$
Undervoltage Lockout Trip Point	$V_{IN}$ rising	4.00		4.25	V
	$V_{IN}$ falling	3.90		4.15	
Overvoltage Lockout Trip Point		6.25		6.75	V
IN Input Current	Li+, NiMH/NiCd, and no-battery modes			8	mA
	Disable mode			3	
BATT Input Current	$V_{BATT} = 4.3V$			80	$\mu A$
	$V_{IN} = 0$			10	
	Disable mode			6	
Leakage into Battery	$V_{IN} = V_{INP} = 13V$ , $V_{BATT} = 0$   Disable mode			5	$\mu A$
RMS Charge Current				1.4	A
Battery Regulation Voltage	Li+ mode	SELV = VL	4.148	4.252	V
		SELV = GND	4.05	4.15	
	NiMH/NiCd mode	SELV = VL	4.85	5.05	
		SELV = GND	4.4	4.6	
Output Regulation Voltage	No-battery mode	3.700		4.234	V
BATT Precharge Threshold Voltage	BATT rising	2.675		2.925	V
Fast-Charge Current-Loop System Accuracy	$R_{SET1} = 2.8k\Omega$	460		540	mA
	$R_{SET1} = 1.75k\Omega$	736		864	
Precharge Current System Accuracy	% of fast-charge current, $V_{BATT} = 2V$	5		15	%
Current-Sense Amplifier Gain	$I_{BATT}$ to $I_{SET1}$ , precharge mode, $V_{BATT} = 2V$	0.60		1.40	mA/A
	$I_{BATT}$ to $I_{SET1}$ , fast-charge mode	0.93		1.07	
Regulator Dropout Voltage	$V_{IN} - V_{BATT}$ , NiMH/NiCd mode, $V_{BATT} = 4.3V$ , $I_{BATT} = 425mA$			350	mV
Logic Input Low Voltage	$\overline{CHGEN}$ , $\overline{MODE}$ , $4.5V < V_{IN} < 6.25V$			0.52	V
Logic Input High Voltage	$\overline{CHGEN}$ , $\overline{MODE}$ , $4.5V < V_{IN} < 6.25V$	1.3			V
Internal Pulldown Resistance	$\overline{CHGEN}$ , $\overline{MODE}$	100		400	$k\Omega$
Internal Pullup Resistance	SELV	100		400	$k\Omega$
Internal Bias Resistance	FULLI, TEMP, TMAX	50		200	$k\Omega$

# MAX1501

## Highly Integrated, Linear Battery Charger with Thermal Regulation for Portable Applications

### ELECTRICAL CHARACTERISTICS (continued)

( $V_{IN} = V_{INP} = 5V$ ,  $V_{BATT} = 3.5V$ ,  $\overline{ACOK} = \overline{GLED} = \overline{RLED} = TEMP = TMAX/I.C. = FULLI = open$ ,  $\overline{CHGEN} = \overline{MODE} = GND$ ,  $R_{SET1} = 2.8k\Omega$ ,  $C_{IN} = 1\mu F$ ,  $C_{BATT} = 10\mu F$ ,  $T_A = -40^\circ C$  to  $+85^\circ C$ , unless otherwise noted. Typical values are at  $T_A = +25^\circ C$ .) (Note 2)

PARAMETER	CONDITIONS	MIN	TYP	MAX	UNITS
$\overline{RLED}$ Output Low Current	$V_{\overline{RLED}} = 1V$	7		18	mA
$\overline{GLED}$ Output Low Current	$V_{\overline{GLED}} = 1V$	14		34	mA
$\overline{GLED}$ , $\overline{RLED}$ Output High Leakage Current	$V_{\overline{GLED}} = V_{\overline{RLED}} = V_{IN} = V_{INP} = 13V$			1	$\mu A$
Charge-Timer Accuracy (MAX1501 Only)		-10		+10	%

**Note 1:** Temperature regulation setpoint variation is typically  $\pm 9^\circ C$ .

**Note 2:** Specifications to  $T_A = -40^\circ C$  are guaranteed by design, not production tested.

### Typical Operating Characteristics

( $V_{IN} = V_{INP} = 5V$ ,  $\overline{ACOK} = \overline{RLED} = \overline{GLED} = TEMP = TMAX/I.C. = FULLI = open$ ,  $C_{BATT} = 10\mu F$ ,  $C_{IN} = 1\mu F$ ,  $T_A = +25^\circ C$ , unless otherwise noted.)

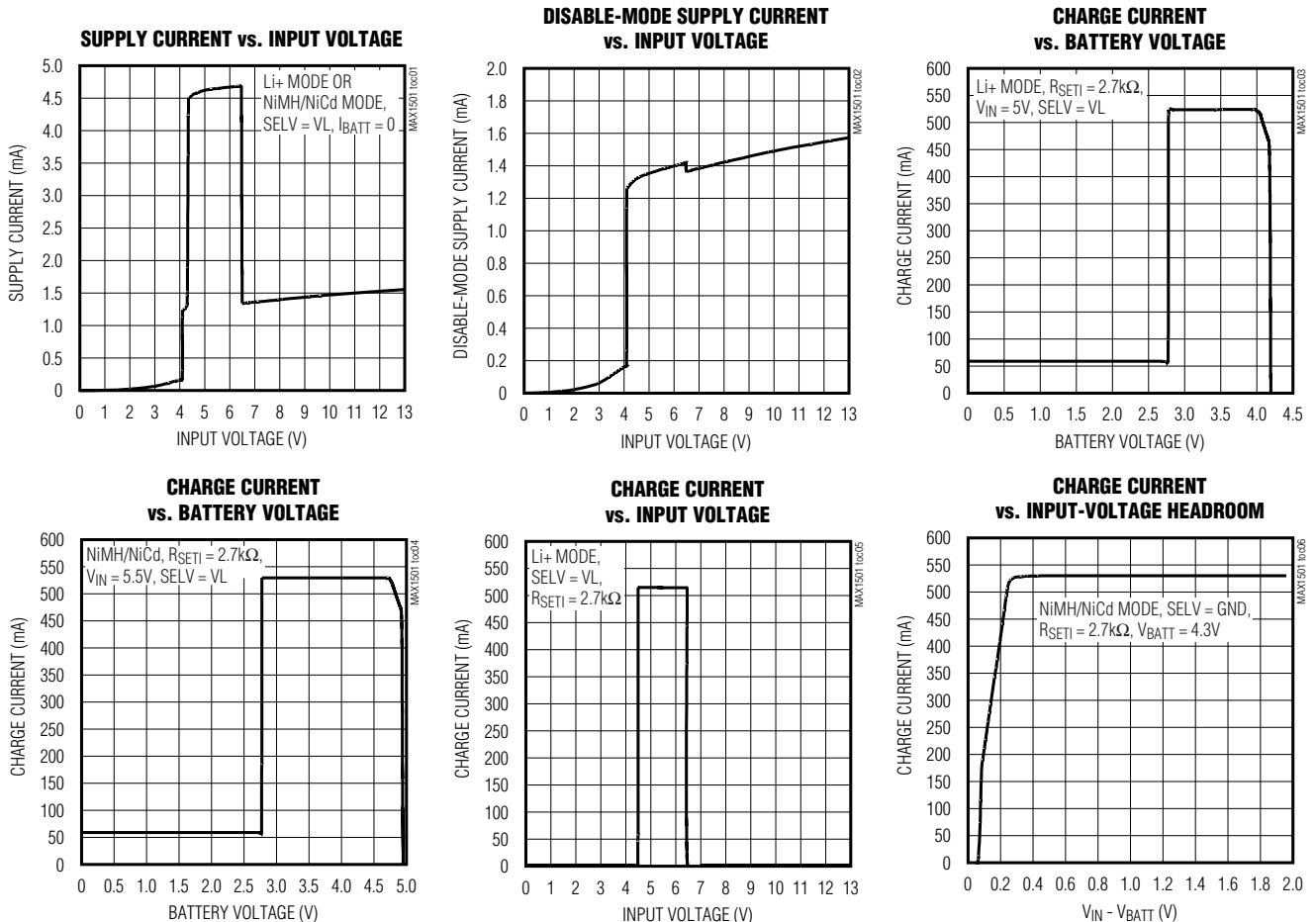

# MAX1501

## Highly Integrated, Linear Battery Charger with Thermal Regulation for Portable Applications

### Typical Operating Characteristics (continued)

( $V_{IN} = V_{INP} = 5V$ ,  $\overline{ACOK} = \overline{RLED} = \overline{GLED} = TEMP = TMAX/I.C. = FULLI = open$ ,  $C_{BATT} = 10\mu F$ ,  $C_{IN} = 1\mu F$ ,  $T_A = +25^\circ C$ , unless otherwise noted.)

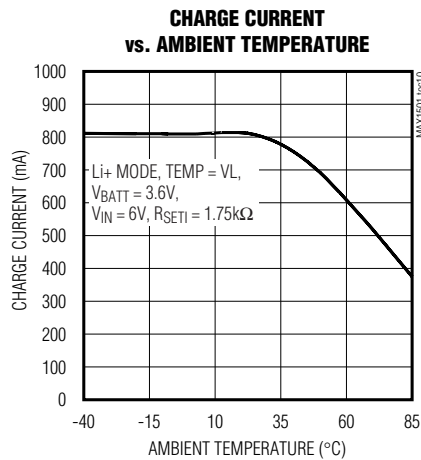
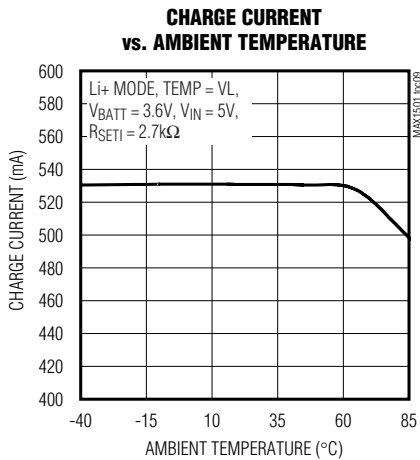
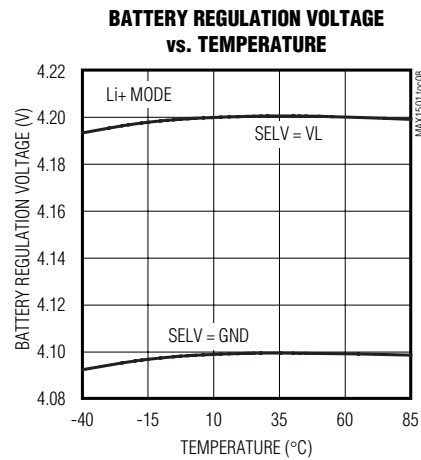
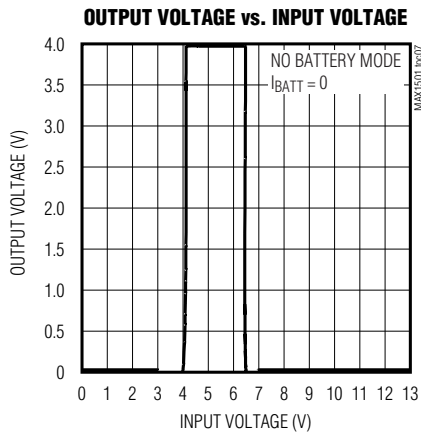

# MAX1501

## Highly Integrated, Linear Battery Charger with Thermal Regulation for Portable Applications

### Pin Description

PIN	NAME	FUNCTION
1	INP	High-Current Charger Input. Connect an AC adapter to INP and IN as close to the device as possible. INP provides charge current to the battery. INP draws current while the device is in shutdown mode.
2	IN	Low-Current Charger Input. Bypass IN to GND with a 1 $\mu$ F ceramic capacitor. Connect IN to INP as close to the device as possible. IN powers the internal LDO and reference. IN draws current while the device is in shutdown mode.
3, 13	GND	Ground. Connect the exposed paddle to GND.
4	SETI	Current-Sense Transconductance Amplifier Output. Connect a resistor from SETI to GND to program the maximum charge current and to monitor the actual charge current. SETI pulls to GND during shutdown.
5	VL	Linear Regulator Output. Connect $\overline{\text{CHGEN}}$ , $\overline{\text{TEMP}}$ , $\overline{\text{TMAX}}$ , $\overline{\text{FULLI}}$ , and $\overline{\text{MODE}}$ to VL to program logic high. VL discharges to GND during shutdown.
6	TMAX	Maximum Charging-Time Select Input (MAX1501 Only). TMAX sets the maximum charging time. Connect TMAX to GND to set the maximum charging time to 3 hours. Leave TMAX floating to set the maximum charging time to 4.5 hours. Connect TMAX to VL to set the maximum charging time to 6 hours. TMAX pulls to GND through a 50k $\Omega$ resistor in shutdown.
	I.C.	Internally Connected in the MAX1501Z. Leave floating.
7	FULLI	Top-Off-Current Select Input. FULLI sets the end-of-charge threshold as a percentage of the fast-charge current. Connect FULLI to GND to set the end-of-charge threshold to 10% of the fast-charge current. Connect FULLI to VL to set the end-of-charge threshold to 20% of the fast-charge current. Leave FULLI floating to set the end-of-charge threshold to 30% of the fast-charge current. FULLI pulls to GND through a 50k $\Omega$ resistor in shutdown.
8	TEMP	Die Temperature Select Input. TEMP sets the die temperature regulation point for the thermal-control loop. Connect TEMP to GND to regulate the die temperature at +95 $^{\circ}$ C. Leave TEMP floating to regulate the die temperature at +115 $^{\circ}$ C. Connect TEMP to VL to regulate the die temperature at +135 $^{\circ}$ C. TEMP pulls to GND through a 50k $\Omega$ resistor in shutdown.
9	$\overline{\text{MODE}}$	Mode Select Input. $\overline{\text{MODE}}$ and $\overline{\text{CHGEN}}$ together control charging functions (Table 1). An internal 175k $\Omega$ pulldown resistor pulls $\overline{\text{MODE}}$ low.
10	$\overline{\text{CHGEN}}$	Charge Enable Input. $\overline{\text{CHGEN}}$ and $\overline{\text{MODE}}$ together control charging functions (Table 1). An internal 175k $\Omega$ pulldown resistor pulls $\overline{\text{CHGEN}}$ low.
11	$\overline{\text{ACOK}}$	Input Voltage Range Indicator. The open-drain $\overline{\text{ACOK}}$ output asserts low when $4.2\text{V} \leq V_{\text{IN}} \leq 6.25\text{V}$ and $V_{\text{IN}} - V_{\text{BATT}} \geq 100\text{mV}$ . $\overline{\text{ACOK}}$ requires an external 100k $\Omega$ pullup resistor. $\overline{\text{ACOK}}$ floats in shutdown.
12	BATT	Battery Connection. Connect the positive terminal of the battery to BATT. BATT draws less than 5 $\mu$ A during shutdown.
14	SELV	Battery Voltage Selection Input. SELV sets the battery regulation voltage in Li+ and NiMH/NiCd modes (Table 2). For no-battery mode, the battery voltage defaults to 4.0V. An internal 175k $\Omega$ resistor to VL pulls SELV high.
15	$\overline{\text{RLED}}$	Battery Charging Indicator. Connect the anode of a red LED to IN and the cathode to $\overline{\text{RLED}}$ . $\overline{\text{RLED}}$ asserts low when the input supply is present and the battery is charging, regardless of cell chemistry. $\overline{\text{RLED}}$ sinks 10mA. $\overline{\text{RLED}}$ goes high impedance in shutdown. Connect a pullup resistor to the $\mu$ P's I/O supply when interfacing with a $\mu$ P logic input.
16	$\overline{\text{GLED}}$	Full-Charge Indicator. Connect the anode of a green LED to IN and the cathode to $\overline{\text{GLED}}$ . $\overline{\text{GLED}}$ asserts low when the input supply is present and the battery has reached the top-off current threshold set by FULLI, regardless of cell chemistry. $\overline{\text{GLED}}$ sinks 20mA. $\overline{\text{GLED}}$ goes high impedance in shutdown. Connect a pullup resistor to the $\mu$ P's I/O supply when interfacing with a $\mu$ P logic input.



# MAX1501

## Highly Integrated, Linear Battery Charger with Thermal Regulation for Portable Applications

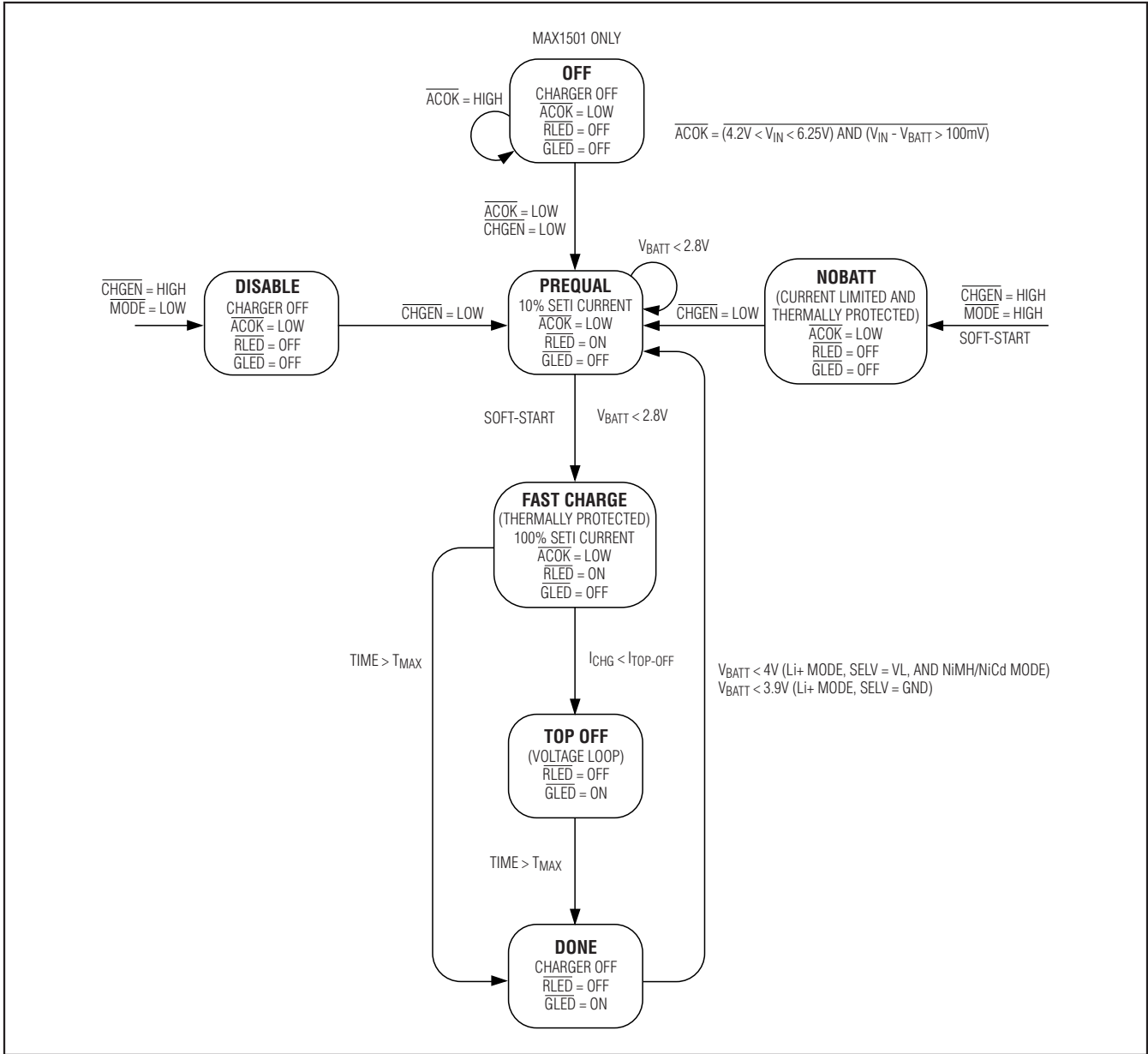

Figure 2. MAX1501 Charge State Diagram

# MAX1501

## Highly Integrated, Linear Battery Charger with Thermal Regulation for Portable Applications

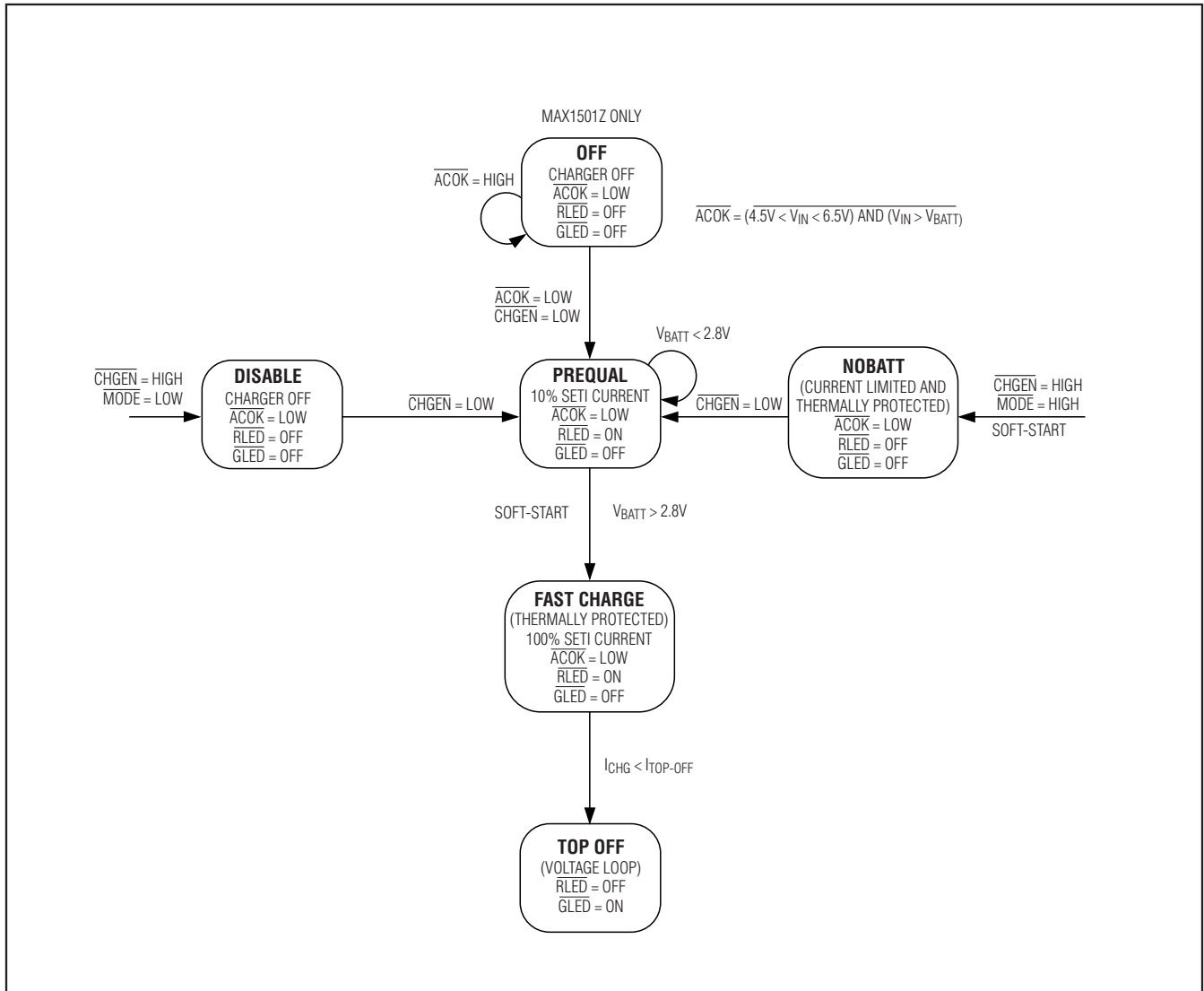

Figure 3. MAX1501Z Charge State Diagram

### Detailed Description

#### Modes of Operation

$\overline{\text{CHGEN}}$  and  $\overline{\text{MODE}}$  together set the operating modes of the MAX1501. Both inputs possess internal 175kΩ pulldown resistors to GND. Table 1 describes the four operating modes of the MAX1501.

Table 1. Modes of Operation

MODE	$\overline{\text{CHGEN}}$	$\overline{\text{MODE}}$
Li+ Charge Mode	0	0
NiMH/NiCd Charge Mode	0	1
Disable Mode	1	0
No-Battery Mode	1	1

# MAX1501

## Highly Integrated, Linear Battery Charger with Thermal Regulation for Portable Applications

**Table 2. Battery Regulation Voltage**

CHARGING MODE	SELV	
	GND	VL
Li+	4.1V	4.2V
NiMH/NiCd	4.5V	4.95V

### Li+ Charge Mode

Connect  $\overline{\text{CHGEN}}$  and  $\overline{\text{MODE}}$  to GND to place the MAX1501 in Li+ charging mode. The Li+ charger consists of a voltage-control loop, a current-control loop, and a thermal-control loop. Connect SELV to GND to set the Li+ battery voltage to 4.1V. Connect SELV to VL to set the Li+ battery voltage to 4.2V (Table 2).

The MAX1501 precharges the Li+ battery with 10% of the user-programmed fast-charge current at the start of a charge cycle. A soft-start algorithm ramps up the charging current (10% steps with 20ms duration per step) to the fast-charge current when the battery voltage reaches 2.8V. The MAX1501 enters constant-voltage mode and decreases the charge current when the BATT voltage reaches the selected regulation voltage (4.1V or 4.2V). Set the fast-charge current with a resistor between SET1 and GND (see the *Charge-Current Selection* section).

The thermal-regulation loop limits the MAX1501 die temperature to the value selected by the TEMP input by reducing the charge current as necessary (see the *Thermal-Regulation Selection* section). This feature not only protects the MAX1501 from overheating, but also allows the charge current to be set higher without risking damage to the system.

Set the top-off-current threshold with the three-state FULL1 input (see the *Top-Off-Current Selection* section).  $\overline{\text{RLED}}$  goes high impedance and  $\overline{\text{GLED}}$  asserts low when the top-off-current threshold is reached. The MAX1501 automatically initiates recharging when the battery voltage drops below 95% of the voltage set by SELV. (The MAX1501Z does not time out.)

### NiMH/NiCd Charge Mode

Connect  $\overline{\text{MODE}}$  to VL to place the MAX1501 in NiMH/NiCd charging mode. NiMH/NiCd mode uses only current- and voltage-control loops, and is intended for trickle- or timer-based chargers. Fast charge termination schemes, such as negative  $\Delta V$  or  $\Delta T$ , are not included in the MAX1501 but can be implemented using an external microcontroller. Trickle- or timer-based chargers should connect SELV to GND to set the regulation voltage to 4.5V.  $\mu\text{P}$  controlled chargers should connect SELV to VL

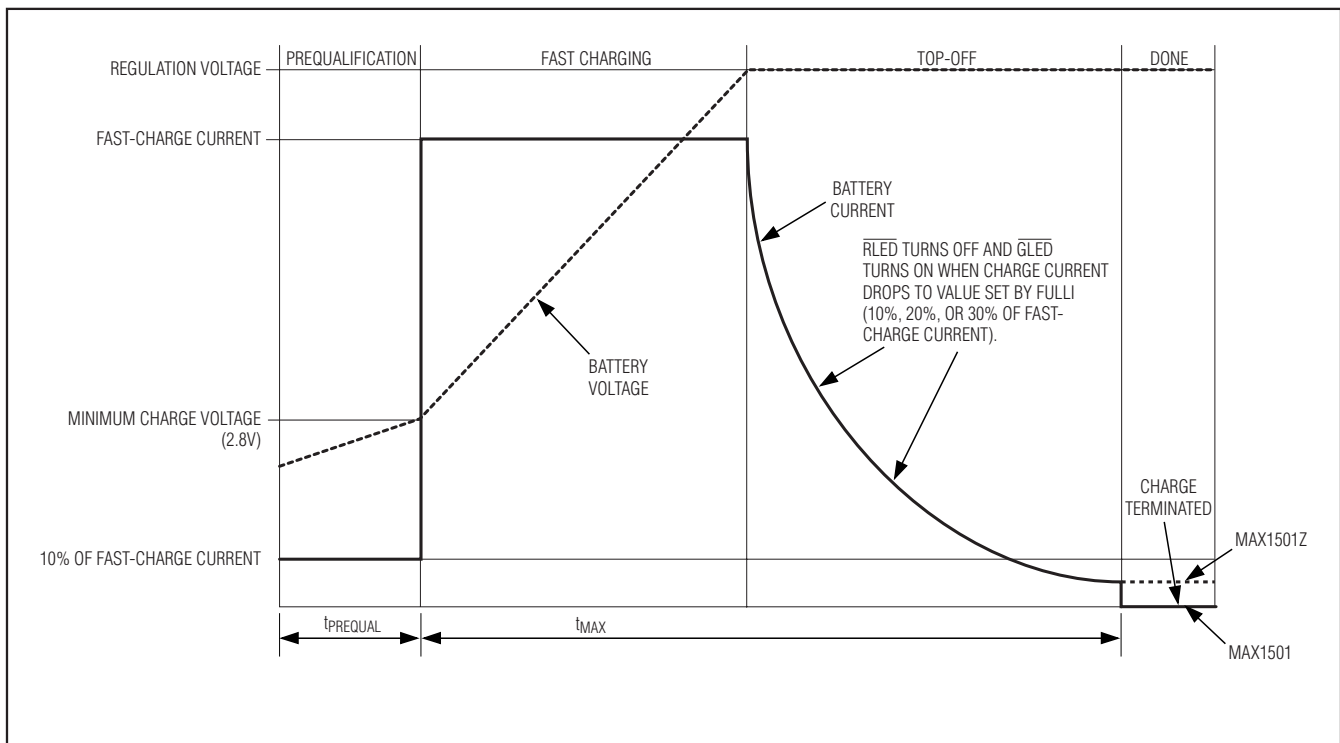

Figure 4. Li+ Charge Sequence

# MAX1501

## Highly Integrated, Linear Battery Charger with Thermal Regulation for Portable Applications

Table 3.  $\overline{\text{RLED}}$  and  $\overline{\text{GLED}}$  Behavior

MODE	STATE	$\overline{\text{RLED}}$	$\overline{\text{GLED}}$
Li+ Mode or NiMH/NiCd Mode	<ul style="list-style-type: none"><li>• 10% current-limited precharge</li><li>• Current-limited charge</li><li>• Voltage-limited charge before top-off</li><li>• Temperature-limited charge before top-off</li></ul>	Sinks 10mA	High impedance
	<ul style="list-style-type: none"><li>• Voltage-limited charge after top-off</li><li>• Safety timer expires (MAX1501 only)</li></ul>	High impedance	Sinks 20mA
Disable Mode	—	High impedance	High impedance
No Battery Mode	—	High impedance	High impedance

to set the regulation voltage to 4.95V to not interfere with  $\mu\text{P}$  charge control. When the regulation voltage is 4.95V,  $V_{\text{IN}}$  must be  $\geq 5.25\text{V}$ .

The MAX1501 precharges with 10% of the user-programmed charge current at the start of a charge cycle. Fast charge begins when  $V_{\text{BATT}}$  exceeds 2.8V. A resistor from SET1 to GND sets charge current. See the *Charge-Current Selection* section. The MAX1501 enters voltage mode and decreases charge current when  $V_{\text{BATT}}$  reaches 4.5V.

The thermal-regulation loop limits die temperature to the value selected by TEMP by reducing charge current. See the *Thermal-Regulation Selection* section. This protects the MAX1501 from overheating when supplying high charge currents, or operating from high input voltages.

Set the top-off-current threshold with the three-state FULL1 input. See the *Top-Off-Current Selection* section.  $\overline{\text{RLED}}$  goes high impedance and  $\overline{\text{GLED}}$  asserts low when the top-off current threshold is reached. The MAX1501 automatically initiates recharging when the battery voltage drops below 4V. The MAX1501Z does not time out.

### No-Battery Mode

Connect CHGEN and MODE to VL to place the MAX1501 in no-battery mode. An external load can be connected to BATT in this mode.  $V_{\text{BATT}}$  regulates to 4V in no-battery mode, regardless of the state of SELV.

The current-control loop, voltage-control loop, and thermal-control loop all function in no-battery mode. The loop gain of the voltage-control loop decreases to ensure stability with no battery present. Connect a  $10\mu\text{F}$  ceramic capacitor to BATT for stability.  $\overline{\text{RLED}}$  and  $\overline{\text{GLED}}$  are both high impedance in no-battery mode.

### ACOK

The  $\overline{\text{ACOK}}$  output asserts low when  $V_{\text{IN}}$  is present,  $4.2\text{V} \leq V_{\text{IN}} \leq 6.25\text{V}$ , and  $V_{\text{IN}} - V_{\text{BATT}} > 100\text{mV}$ . The  $\overline{\text{ACOK}}$  open-drain output requires an external  $100\text{k}\Omega$  pullup

resistor to an external supply voltage. The external supply voltage must be less than 5.5V.

### $\overline{\text{RLED}}$ and $\overline{\text{GLED}}$ Indicators

$\overline{\text{RLED}}$  and  $\overline{\text{GLED}}$  serve as visual indicators that power is applied as well as the charge status of a battery.  $\overline{\text{RLED}}$  asserts low when a wall adapter is connected and a battery is charging, regardless of cell chemistry.  $\overline{\text{GLED}}$  asserts low when power is applied and the battery is fully charged. Both outputs go high-impedance in shutdown. Connect the anode of each LED to IN, and the cathode to  $\overline{\text{RLED}}$  or  $\overline{\text{GLED}}$ . Table 3 summarizes the behavior of  $\overline{\text{RLED}}$  and  $\overline{\text{GLED}}$  under normal operating conditions. Connect pullup resistors to the  $\mu\text{P}$  I/O supply when interfacing  $\overline{\text{RLED}}$  and  $\overline{\text{GLED}}$  with a  $\mu\text{P}$ 's logic inputs.

### Soft-Start

A ten-step, soft-start algorithm activates when entering fast-charge mode. The charging current ramps up in 10% increments, 20ms per step, to the full charging current when  $V_{\text{BATT}}$  exceeds 2.8V.

## Applications Information

### Charge-Current Selection

Program the charging current using an external resistor between SET1 and GND. Set the charge-current resistor with the following equation:

$$R_{\text{SET1}} = 1000 \times \frac{1.4\text{V}}{I_{\text{BATT}}}$$

If  $V_{\text{SET1}} = 1.4\text{V}$ , the current-control loop controls the battery charging. If  $V_{\text{SET1}} < 1.4\text{V}$ , either the voltage-control loop or the thermal-control loop operates. Measure the charging current by monitoring  $V_{\text{SET1}}$  and using the following equation:

$$V_{\text{SET1}} = \frac{I_{\text{BATT}}}{1000} \times R_{\text{SET1}}$$

# MAX1501

## Highly Integrated, Linear Battery Charger with Thermal Regulation for Portable Applications

### Thermal-Regulation Selection

Set the regulated die temperature of the MAX1501 with the TEMP three-level logic input. The MAX1501 reduces the charge current to limit the die temperature to the value set by TEMP. The MAX1501 operates normally while the thermal loop is active. An active thermal loop does not indicate a fault condition. TEMP allows the MAX1501 to maximize the charge current while providing protection against excessive power dissipation.

Connect TEMP to GND to regulate the die temperature at +95°C. Leave TEMP floating to regulate the die temperature at +115°C. Connect TEMP to VL to regulate the die temperature at +135°C.

### Top-Off-Current Selection

Set the top-off-current threshold in the Li+ and NiMH/NiCd charge modes with the FULLI three-level logic input. The top-off-current threshold determines when  $\overline{\text{RLED}}$  turns off and  $\overline{\text{GLED}}$  turns on, indicating the charge status of the battery.

Connect FULLI to GND to set the top-off-current threshold to 10% of the fast-charge current. Connect FULLI to VL to set the top-off-current threshold to 20% of the fast-charge current. Leave FULLI floating to set the top-off-current threshold to 30% of the fast-charge current.

### Charge-Timer Selection (MAX1501 Only)

Set the maximum charging time with the TMAX three-level logic input. TMAX limits the duration of charging to protect the battery from overcharging. Connect TMAX to GND to set the maximum charging time to 3 hours. Leave TMAX floating to set the maximum charging time

to 4.5 hours. Connect TMAX to VL to set the maximum charging time to 6 hours.

### Capacitor Selection

Connect a ceramic capacitor from BATT to GND for proper stability. Use a 10 $\mu\text{F}$  X5R ceramic capacitor for most applications.

Connect IN and INP together and bypass to GND with a 1 $\mu\text{F}$  ceramic capacitor. Use a larger input bypass capacitor for high input voltages or high charging currents to reduce supply noise.

### Thermal Considerations

The MAX1501 is available in a thermally enhanced thin QFN package with exposed paddle. Connect the exposed paddle of the MAX1501 to a large copper ground plane to provide a thermal contact between the device and the circuit board. The exposed paddle transfers heat away from the device, allowing the MAX1501 to charge the battery with maximum current, while minimizing the increase in die temperature.

### Application Circuits

Figure 5 shows the MAX1501 as a stand-alone Li+ battery charger. The 2.8k $\Omega$  resistor connected to SET1 sets a charging current of 500mA.

Figure 6 shows the MAX1501 as a  $\mu\text{P}$ -based Li+ battery charger. Drive  $\overline{\text{CHGEN}}$  low to charge the battery. Drive  $\overline{\text{CHGEN}}$  high to disable the charger. Connect a 100k $\Omega$  pullup resistor from  $\overline{\text{ACOK}}$  to the logic supply voltage of the  $\mu\text{P}$  to detect the presence of an input supply. The logic supply voltage must be less than 5.5V.

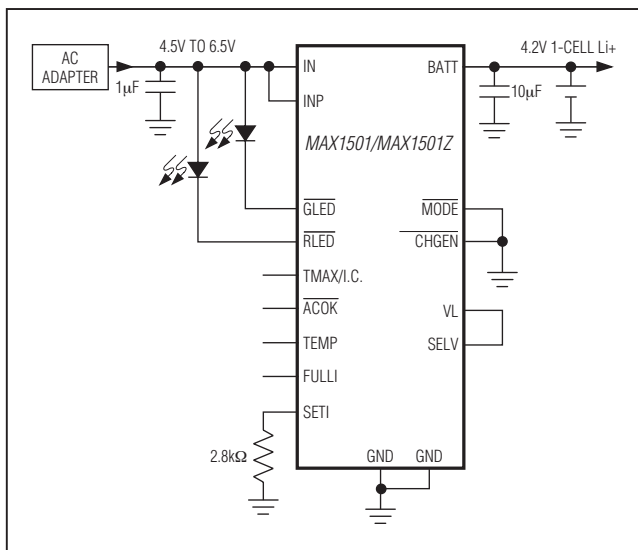

Figure 5. Stand-Alone Li+ Battery Charger

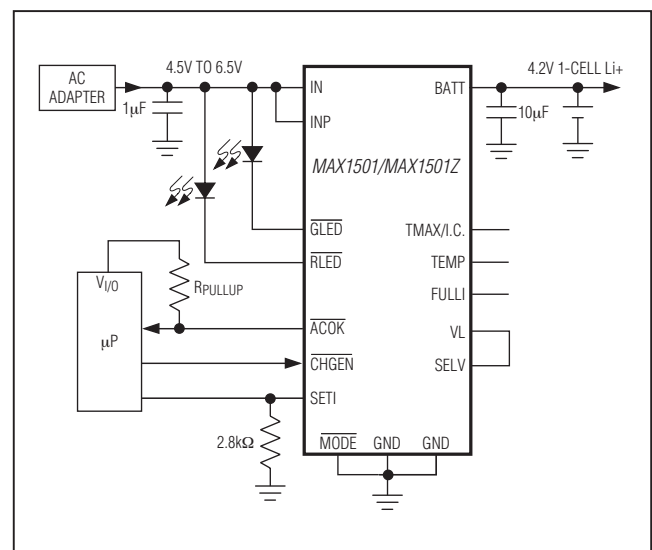

Figure 6.  $\mu\text{P}$ -Based Li+ Battery Charger

# MAX1501

## Highly Integrated, Linear Battery Charger with Thermal Regulation for Portable Applications

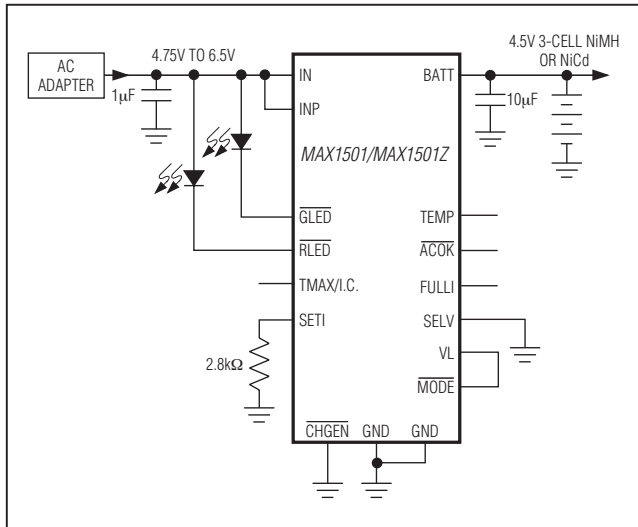

Figure 7. Stand-Alone 3-Cell NiMH or NiCd Battery Charger

Figure 7 shows the MAX1501 as a stand-alone trickle or timer-based NiMH/NiCd battery charger. Connecting SELV to GND sets the charge termination voltage to 4.5V.

Figure 8 shows the MAX1501 as a  $\mu$ P-based NiMH/NiCd battery charger. Connecting SELV to VL sets the charge regulation voltage at 4.95V. Connect a 100k $\Omega$  pullup resistor from  $\overline{\text{ACOK}}$  to the logic supply voltage of the  $\mu$ P. The logic supply voltage must be less than 5.5V.

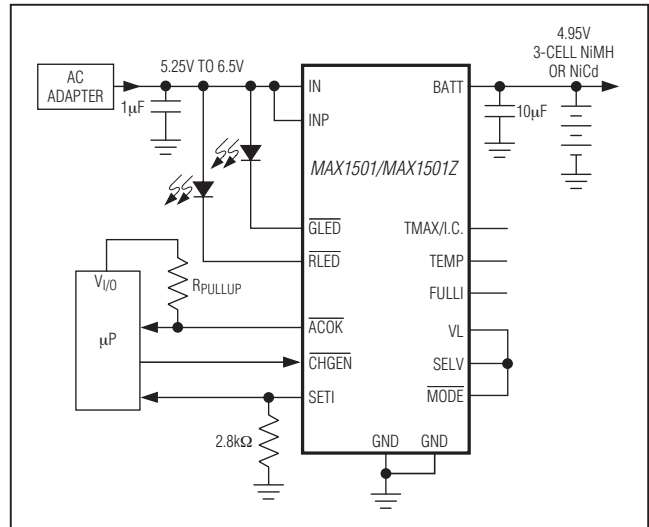

Figure 8.  $\mu$ P-Based NiMH or NiCd Battery Charge

Figure 9 shows the MAX1501 as a  $\mu$ P-based single Li+ or 3-cell NiMH/NiCd charger. The states of  $\overline{\text{MODE}}$  and  $\overline{\text{CHGEN}}$  set the operating mode of the MAX1501 (Table 1). Connect a 100k $\Omega$  pullup resistor from  $\overline{\text{ACOK}}$  to the logic supply voltage of the  $\mu$ P. The logic supply voltage must be less than 5.5V.

Figure 10 shows the MAX1501 as an accurate current-limited low-dropout linear regulator with input overvoltage protection (no-battery mode). The output voltage regulates to 4V, regardless of the state of SELV. Connect  $\overline{\text{MODE}}$  to VL to enable the linear regulator. Connect  $\overline{\text{MODE}}$  to GND to put the device into shut-down. RSETI sets the maximum output current.

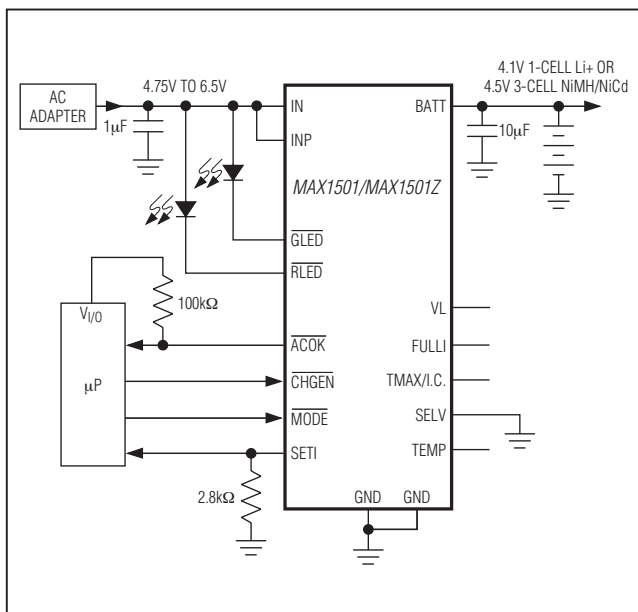

Figure 9.  $\mu$ P-Based Single Li+/3-Cell NiMH/NiCd Battery Charger

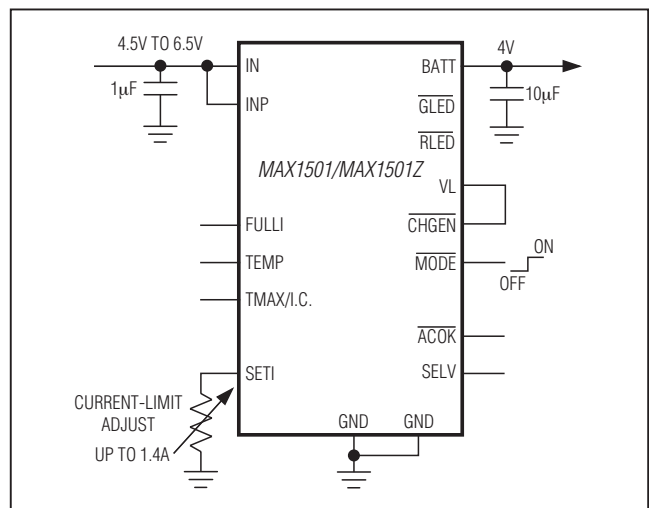

Figure 10. Input Overvoltage-Protected and Current-Limited Low-Dropout Linear Regulator

# MAX1501

## Highly Integrated, Linear Battery Charger with Thermal Regulation for Portable Applications

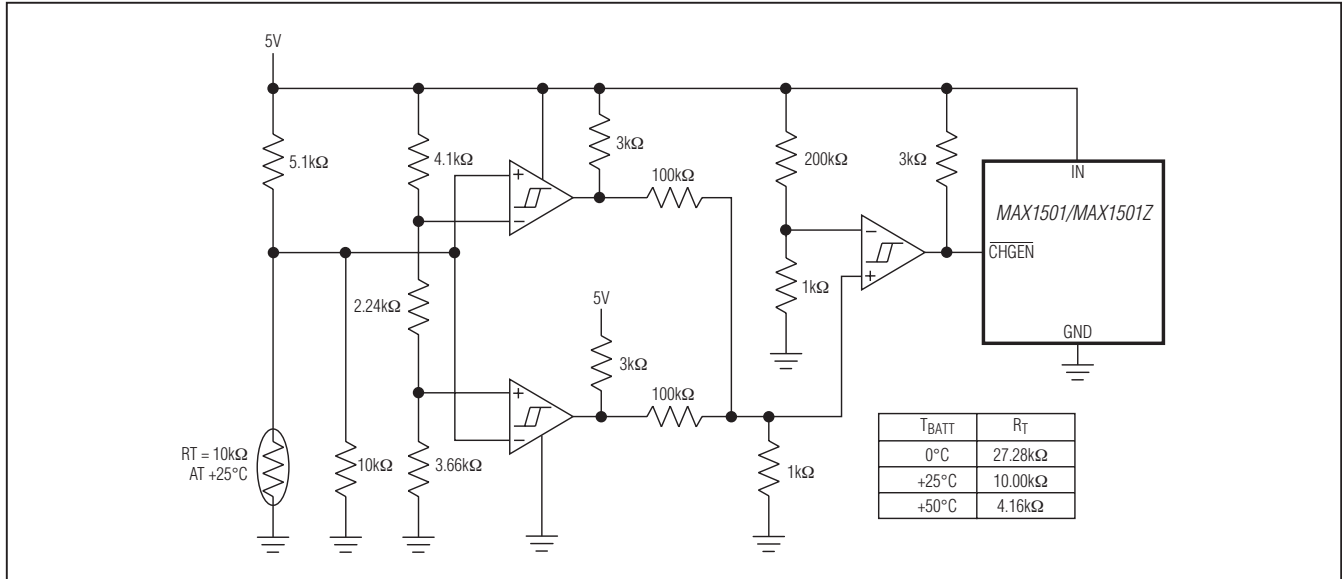

Figure 11. Battery Temperature Protection

Figure 11 shows a circuit that adds temperature protection to the battery. Install the thermistor as close to the battery as possible to ensure accurate temperature measurement. The output of this circuit is logic high when the battery temperature is less than 0°C and greater than +50°C. Driving  $\overline{\text{CHGEN}}$  high disables the charger.

### Layout and Bypassing

Connect IN and INP together as close to the device as possible and bypass with a 1μF ceramic capacitor. Bypass BATT to GND with a 10μF ceramic capacitor.

Provide a large copper GND plane to allow the exposed paddle to sink heat away from the device. Connect the battery to BATT as close to the device as possible to provide the most accurate battery voltage sensing. Make all high-current traces short and wide to minimize voltage drops.

### Chip Information

TRANSISTOR COUNT: 5717

PROCESS: BiCMOS

### Pin Configuration

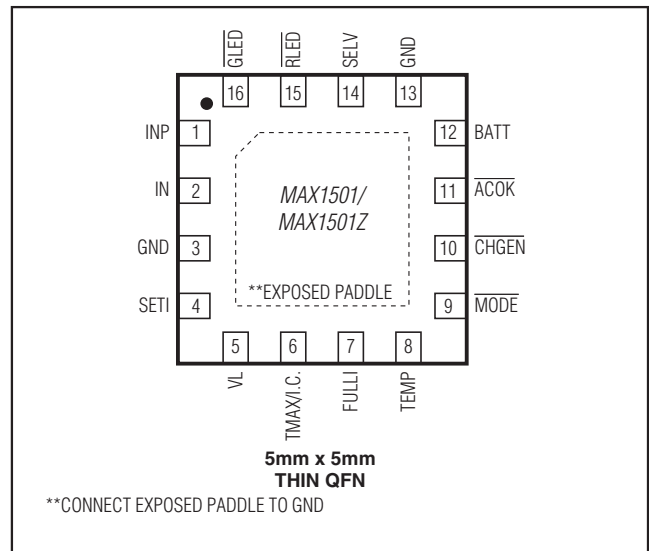

### Package Information

For the latest package outline information and land patterns (footprints), go to [www.maximintegrated.com/packages](http://www.maximintegrated.com/packages). Note that a "+", "#", or "-" in the package code indicates RoHS status only. Package drawings may show a different suffix character, but the drawing pertains to the package regardless of RoHS status.

PACKAGE TYPE	PACKAGE CODE	OUTLINE NO.	LAND PATTERN NO.
16 TQFN	T1655+3	<a href="#">21-0140</a>	<a href="#">90-0073</a>

# MAX1501

## Highly Integrated, Linear Battery Charger with Thermal Regulation for Portable Applications

### Revision History

REVISION NUMBER	REVISION DATE	DESCRIPTION	PAGES CHANGED
2	4/14	Updated <i>General Description</i> , <i>NiMH/NiCd Charge Mode</i> , and <i>Application Circuits</i> sections	1, 11, 12, 14, 16



Maxim Integrated cannot assume responsibility for use of any circuitry other than circuitry entirely embodied in a Maxim Integrated product. No circuit patent licenses are implied. Maxim Integrated reserves the right to change the circuitry and specifications without notice at any time. The parametric values (min and max limits) shown in the Electrical Characteristics table are guaranteed. Other parametric values quoted in this data sheet are provided for guidance.

## Looking for pricing, stock, or lifecycle information?

Click below to explore more details on WIN SOURCE:

 [View MAX1501ETE+ on WIN SOURCE](#)

 [Maxim Integrated](#) Information

## Optimize Your Supply Chain with WIN SOURCE Solutions

-  Global Sourcing Solution
-  Obsolete Management
-  Cost Control Management
-  Shortage Management
-  Alternative Solution
-  Excess Inventory Management