



**THE DATASHEET OF
LTC6810IG-2#3ZZPBF**



6 Channel Battery Stack Monitors

FEATURES

- AEC-Q100 Qualified for Automotive Applications
- Measures Up to 6 Battery Cells in Series
- 1.8mV Maximum Total Measurement Error
- Stackable Architecture for High Voltage Systems
- 290µs to Measure All Cells in a System.
- Built-in isoSPI™ Interface
 - 1Mb Isolated Serial Communications
 - Uses Single Twisted Pair, Up to 100 Meters
 - Low EMI Susceptibility and Emissions
 - Bidirectional for Broken Wire Protection
- Guaranteed Performance Down to 5V
- Performs Redundant Cell Measurements.
- Engineered for ISO 26262 Compliant Systems
- Passive Cell Balancing with Programmable PWM
- 4 General Purpose Digital I/O or Analog Inputs
 - Temperature or Other Sensor Inputs
 - Configurable as an I²C or SPI master
- 4µA Sleep Mode Supply Current
- 44-Lead SSOP Package

APPLICATIONS

- Electric and Hybrid Electric Vehicles
- Backup Battery Systems
- Grid Energy Storage
- High Power Portable Equipment

DESCRIPTION

The **LTC®6810** is a multicell battery stack monitor. The LTC6810 measures up to 6 series-connected battery cells with a total measurement error of less than 1.8mV. The cell measurement range of 0V to 5V makes the LTC6810 suitable for most battery chemistries. All 6 cells can be measured in 290µs, and lower data acquisition rates can be selected for high noise reduction.

Multiple LTC6810-1 devices can be connected in series, permitting simultaneous cell monitoring of long, high voltage battery strings. Each LTC6810 has an isoSPI interface for high speed, RF-immune, long distance communications. Using the LTC6810-1, multiple devices are connected in a daisy chain with one host processor connection for all devices. The LTC6810-1 supports bidirectional operation, allowing communication even with a broken wire. Using the LTC6810-2, multiple devices are connected in parallel to the host processor, with each device individually addressed.

The LTC6810 can be powered directly from the battery stack or from an isolated supply. The LTC6810 includes passive balancing for each cell, with PWM duty cycle control for each cell and the ability to perform redundant cell measurements. Other features include an onboard 5V regulator, 4 general purpose I/O lines and a sleep mode in which current consumption is reduced to 4µA.

All registered trademarks and trademarks are the property of their respective owners.

TYPICAL APPLICATION

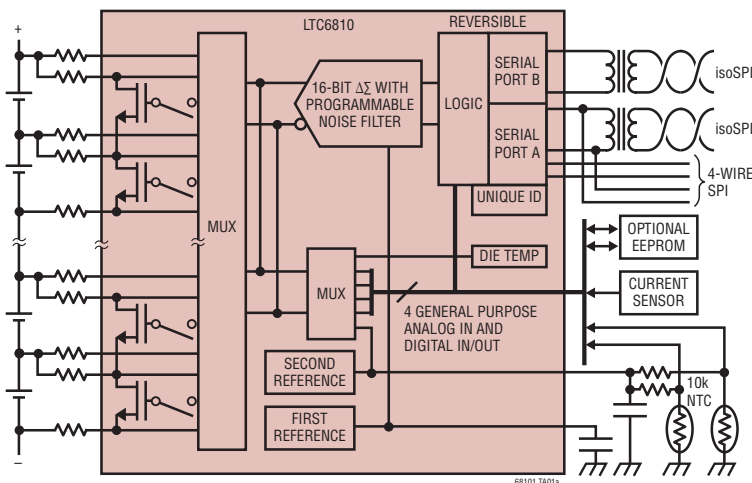

Measurement Error vs V⁺

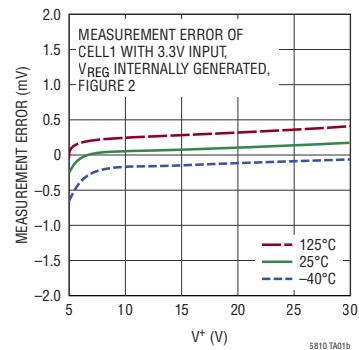

TABLE OF CONTENTS

Features	1
Applications	1
Typical Application	1
Description	1
Absolute Maximum Ratings	3
Pin Configuration	3
Order Information	4
Electrical Characteristics	4
Typical Performance Characteristics	10
Pin Functions	17
Block Diagram	18
Operation	20
State Diagram	20
Core LTC6810 State Descriptions	20
isoSPI State Descriptions	21
Power Consumption	22
V _{REG} Configurations	23
ADC Operation	24
Data Acquisition System Diagnostics	29
Watchdog and Discharge Timer.....	37
Reset Behaviors.....	39
S Pin Pulse Width Modulation for Cell Balancing.....	40
Discharge Timer Monitor	40
I ² C/SPI Master on LTC6810 Using GPIOs.....	40
S Pin Muting.....	44
Serial ID.....	45
Serial Interface Overview	45
4-Wire Serial Peripheral Interface (SPI) Physical Layer.....	45
Data Link Layer	55
Network Layer.....	55
Applications Information	70
Providing DC Power.....	70
Internal Protection and Filtering.....	71
Cell Balancing	72
Discharge Control During Cell Measurements	74
Digital Communications.....	76
Enhanced Applications.....	86
Reading External Temperature Probes	86
Package Description	88
Revision History	89
Typical Application	90
Related Parts	90

ABSOLUTE MAXIMUM RATINGS (Note 1)

Total Supply Voltage, V^+ to V^-	37.5V	S6 to S4.....	-0.3V to 21V
Input Voltage (Relative to V^-)		S4 to S2.....	-0.3V to 21V
C0.....	-0.3V to 5V	S2 to S0.....	-0.3V to 21V
S0.....	-0.3V to 21V	S6 to C3.....	-0.3V to 21V
C(n), S(n) n = 1 TO 3.....	-0.3V to 21V	Current In/Out of Pins	
C(n), S(n) n = 4 TO 5.....	-0.3V to 37.5V	All Pins Except V_{REG} , IPA, IMA, IPB, IMB, S(n)..	10mA
C(6), S(6).....	-0.3V to $\min(V^+ + 5.5V, 37.5V)$	IPA, IMA, IPB, IMB.....	30mA
IPA, IMA, IPB, IMB.....	-0.3V to $V_{REG} + 0.3V, \leq 6V$	Operating Temperature Range	
DRIVE.....	-0.3V to 7V	LTC6810I.....	-40°C to 85°C
All Other Pins.....	-0.3V to 6V	LTC6810H.....	-40°C to 125°C
Voltage Between Inputs		Specified Temperature Range	
C(n) to C(n - 1).....	-0.3V to 21V	LTC6810I.....	-40°C to 85°C
S(n) to C(n - 1).....	-0.3V to 21V	LTC6810H.....	-40°C to 125°C
C6 to C3.....	-0.3V to 21V	Junction Temperature.....	150°C
C3 to C0.....	-0.3V to 21V	Storage Temperature Range.....	-65°C to 150°C

PIN CONFIGURATION

<p>LTC6810-1</p> <div style="text-align: center;">TOP VIEW</div> <p style="text-align: center;">G PACKAGE 44-LEAD PLASTIC SSOP</p> <p style="text-align: center;">$T_{JMAX} = 150^{\circ}C, \theta_{JA} = 50^{\circ}C/W$</p> <p style="text-align: center;">**PINS 1, 21-24, 43 AND 44 ARE FUSED TO THE LEADFRAME. THEY SHOULD BE CONNECTED TO V^- PIN 29</p> <p style="text-align: center;">**THE FUNCTION OF THESE PINS DEPENDS ON THE CONNECTION OF ISOMD ISOMD TIED TO V^-: CSB, SCK, SDI, SDO ISOMD TIED TO V_{REG}: IMA, IPA, NC, NC</p>	<p>LTC6810-2</p> <div style="text-align: center;">TOP VIEW</div> <p style="text-align: center;">G PACKAGE 44-LEAD PLASTIC SSOP</p> <p style="text-align: center;">$T_{JMAX} = 150^{\circ}C, \theta_{JA} = 50^{\circ}C/W$</p> <p style="text-align: center;">**PINS 1, 21-24, 43 AND 44 ARE FUSED TO THE LEADFRAME. THEY SHOULD BE CONNECTED TO V^- PIN 29</p> <p style="text-align: center;">**THE FUNCTION OF THESE PINS DEPENDS ON THE CONNECTION OF ISOMD ISOMD TIED TO V^-: CSB, SCK, SDI, SDO ISOMD TIED TO V_{REG}: IMA, IPA, ICMP, IBIAS</p>
--	---

LTC6810-1/LTC6810-2

ORDER INFORMATION

AUTOMOTIVE PRODUCTS**

TUBE (37PC)	TAPE AND REEL (2000PC)	PART MARKING	PACKAGE DESCRIPTION	MSL RATING	SPECIFIED TEMPERATURE RANGE
LTC6810IG-1#3ZZPBF	LTC6810IG-1#3ZZTRPBF	LTC6810G-1	44-Lead Plastic SSOP	1	-40°C to 85°C
LTC6810HG-1#3ZZPBF	LTC6810HG-1#3ZZTRPBF	LTC6810G-1	44-Lead Plastic SSOP	1	-40°C to 125°C
LTC6810IG-2#3ZZPBF	LTC6810IG-2#3ZZTRPBF	LTC6810G-2	44-Lead Plastic SSOP	1	-40°C to 85°C
LTC6810HG-2#3ZZPBF	LTC6810HG-2#3ZZTRPBF	LTC6810G-2	44-Lead Plastic SSOP	1	-40°C to 125°C

Contact the factory for parts specified with wider operating temperature ranges. *The temperature grade is identified by a label on the shipping container.

Tape and reel specifications. Some packages are available in 500 unit reels through designated sales channels with #TRMPBF suffix.

**Versions of this part are available with controlled manufacturing to support the quality and reliability requirements of automotive applications. These models are designated with a #W suffix. Only the automotive grade products shown are available for use in automotive applications. Contact your local Analog Devices account representative for specific product ordering information and to obtain the specific Automotive Reliability reports for these models.

ELECTRICAL CHARACTERISTICS

The ● denotes the specifications which apply over the full operating temperature range, otherwise specifications are at $T_A = 25^\circ\text{C}$. The test conditions are $V^+ = 19.8\text{V}$, $V_{\text{REG}} = 5.0\text{V}$ unless otherwise noted. The ISOMD pin is tied to the V^- pin, unless otherwise noted.

SYMBOL	PARAMETER	CONDITIONS	MIN	TYP	MAX	UNITS	
ADC DC Specifications							
	Measurement Resolution			0.1		mV/bit	
	ADC Offset Voltage	(Note 2)		0.1		mV	
	ADC Gain Error	(Note 2)		0.03		%	
			●	0.06		%	
	Total Measurement Error (TME) in Normal Mode (Note 3)	C(n) to C(n-1), S(n) to S(n-1), GPIO(n) to $V^- = 0$		±0.2		mV	
		C(n) to C(n-1) = 2.0, GPIO(n) to $V^- = 2.0$		±0.1	±1.2	mV	
		S(n) to S(n-1) = 2.0			±1.7	mV	
		C(n) to C(n-1), GPIO(n) to $V^- = 2.0$	●		±1.6	mV	
		S(n) to S(n-1) = 2.0	●		±2.2	mV	
		C(n) to C(n-1), GPIO(n) to $V^- = 3.3$			±0.2	±1.8	mV
		S(n) to S(n-1) = 3.3				±2.5	mV
		C(n) to C(n-1), GPIO(n) to $V^- = 3.3$	●			±2.4	mV
		S(n) to S(n-1) = 3.3	●			±3.2	mV
		C(n) to C(n-1) = 4.2			±0.3	±2.3	mV
		S(n) to S(n-1) = 4.2				±3.2	mV
		C(n) to C(n-1), GPIO(n) to $V^- = 4.2$	●			±3.1	mV
		S(n) to S(n-1) = 4.2	●			±4.1	mV
		C(n) to C(n-1), S(n) to S(n-1), GPIO(n) to $V^- = 5.0$			±1		mV
	Sum of Cells	●		±0.1	±0.6	%	
	Internal Temperature, T = Maximum Specified Temperature			±5		°C	
	V_{REG} Pin	●		±0.1	±0.25	%	
	V_{REF2} Pin	●		±0.02	±0.1	%	
	Digital Supply Voltage, V_{REGD}	●		±0.1	±1	%	

ELECTRICAL CHARACTERISTICS The ● denotes the specifications which apply over the full operating temperature range, otherwise specifications are at $T_A = 25^\circ\text{C}$. The test conditions are $V^+ = 19.8\text{V}$, $V_{\text{REG}} = 5.0\text{V}$ unless otherwise noted. The ISOMD pin is tied to the V^- pin, unless otherwise noted.

SYMBOL	PARAMETER	CONDITIONS	MIN	TYP	MAX	UNITS	
	Total Measurement Error (TME) in Filtered Mode (Note 3)	C(n) to C(n-1), S(n) to S(n-1), GPIO(n) to $V^- = 0$		±0.1		mV	
		C(n) to C(n-1) = 2.0, GPIO(n) to $V^- = 2.0$		±0.1	±1.2	mV	
		S(n) to S(n-1) = 2.0			±1.7	mV	
		C(n) to C(n-1), GPIO(n) to $V^- = 2.0$	●		±1.6	mV	
		S(n) to S(n-1) = 2.0	●		±2.2	mV	
		C(n) to C(n-1) = 3.3		±0.2	±1.8	mV	
		S(n) to S(n-1) = 3.3			±2.5	mV	
		C(n) to C(n-1), GPIO(n) to $V^- = 3.3$	●		±2.4	mV	
		S(n) to S(n-1) = 3.3	●		±3.2	mV	
		C(n) to C(n-1) = 4.2		±0.3	±2.3	mV	
		S(n) to S(n-1) = 4.2			±3.2	mV	
		C(n) to C(n-1), GPIO(n) to $V^- = 4.2$	●		±3.1	mV	
		S(n) to S(n-1) = 4.2	●		±4.1	mV	
		C(n) to C(n-1), S(n) to S(n-1), GPIO(n) to $V^- = 5.0$			±1	mV	
Sum of Cells	●		±0.1	±0.6	%		
Internal Temperature, T = Maximum Specified Temperature			±5		°C		
V_{REG} Pin	●		±0.1	±0.25	%		
V_{REF2} Pin	●		±0.02	±0.1	%		
Digital Supply Voltage, V_{REGD}	●		±0.1	±1	%		
	Total Measurement Error (TME) in Fast Mode (Note 3)	C(n) to C(n-1), S(n) to S(n-1), GPIO(n) to $V^- = 0$		±2		mV	
		C(n) to C(n-1), GPIO(n) to $V^- = 2.0$	●		4	mV	
		S(n) to S(n-1) = 2.0	●		5	mV	
		C(n) to C(n-1), GPIO(n) to $V^- = 3.3$	●		5.5	mV	
		S(n) to S(n-1) = 3.3	●		6.5	mV	
		C(n) to C(n-1), GPIO(n) to $V^- = 4.2$	●		8	mV	
		S(n) to S(n-1) = 4.2	●		9	mV	
		C(n) to C(n-1), GPIO(n) to $V^- = 5.0$, S(n) to S(n-1) = 5.0			±10	mV	
		Sum of Cells	●		±0.15	±1	%
		Internal Temperature, T = Maximum Specified Temperature			±5		°C
		V_{REG} Pin	●		±0.3	±1	%
V_{REF2} Pin	●		±0.1	±0.25	%		
Digital Supply Voltage, V_{REGD}	●		±0.2	±2	%		
	Input Range	C(n) n = 1 to 6	●	C(n-1)	C(n-1) + 5	V	
		S(n) n = 1 to 6	●	C(n-1)	C(n+1)	V	
		CO/SO	●	0	5	V	
		GPIO(n) n = 1 to 4	●	0	5	V	
I_L	Input Leakage Current When Inputs Are Not Being Measured (State: Core = STANDBY)	C(n), S(n), n = 0 to 6	●	10	±250	nA	
		GPIO(n) n = 1 to 4	●	10	±250	nA	
	Input Current When Inputs Are Being Measured	C(n)/S(n) n = 0 to 6		±1		μA	
		GPIO(n) n = 1 to 4		±1		μA	
	Input Current During Open Wire Detection		●	70	110	140	μA

LTC6810-1/LTC6810-2

ELECTRICAL CHARACTERISTICS The ● denotes the specifications which apply over the full operating temperature range, otherwise specifications are at $T_A = 25^\circ\text{C}$. The test conditions are $V^+ = 19.8\text{V}$, $V_{\text{REG}} = 5.0\text{V}$ unless otherwise noted. The ISOMD pin is tied to the V^- pin, unless otherwise noted.

SYMBOL	PARAMETER	CONDITIONS		MIN	TYP	MAX	UNITS			
Voltage Reference Specifications										
V_{REF1}	1st Reference Voltage	V_{REF1} Pin, No Load	●	3.1	3.2	3.3	V			
	1st Reference Voltage TC	V_{REF1} Pin, No Load			3		ppm/ $^\circ\text{C}$			
	1st Reference Voltage Hysteresis	V_{REF1} Pin, No Load			20		ppm			
	1st Reference V. Long Term Drift	V_{REF1} Pin, No Load			25		ppm/ $\sqrt{\text{kHz}}$			
V_{REF2}	2nd Reference Voltage	V_{REF2} Pin, No Load	●	2.995	3	3.005	V			
		V_{REF2} Pin, 5k Load to V^-	●	2.994	3	3.006	V			
	2nd Reference Voltage TC	V_{REF2} Pin, No Load			10		ppm/ $^\circ\text{C}$			
	2nd Reference Voltage Hysteresis	V_{REF2} Pin, No Load			100		ppm			
	2nd Reference V. Long Term Drift	V_{REF2} Pin, No Load			60		ppm/ $\sqrt{\text{kHz}}$			
	General DC Specifications									
I_{VP}	V^+ Supply Current (See Figure 1: Operation State Diagram)	State: Core = SLEEP, isoSPI = IDLE	$V_{\text{REG}} = 0\text{V}$		5.7	10	μA			
			$V_{\text{REG}} = 0\text{V}$	●	5.7	15	μA			
			$V_{\text{REG}} = 5\text{V}$		3.5	5.5	μA			
			$V_{\text{REG}} = 5\text{V}$	●	3.5	9	μA			
		State: Core = STANDBY Internal REG Disabled		●	14 10	22 45	35 45	μA μA		
		State: Core = REFUP		●	25 20	35 60	50 60	μA μA		
		State: Core = MEASURE		●	30 25	50 50	70 80	μA μA		
$I_{\text{VP_INTREG}}$	Total V^+ Current when Internal REG Enabled = $I_{\text{VP}} + I_{\text{REG}}$	State: Core = STANDBY Internal REG Enabled	●	70 60	130 200	175 200	μA μA			
$I_{\text{REG(CORE)}}$	V_{REG} Supply Current (See Figure 1: Operation State Diagram)	State: Core = SLEEP, isoSPI = IDLE	$V_{\text{REG}} = 5\text{V}$		3.5	6.5	μA			
			$V_{\text{REG}} = 5\text{V}$	●	3.5	9	μA			
		State: Core = STANDBY		●	20 18	48 85	75 85	μA μA		
		State: Core = REFUP		●	1.2 1.1	1.7 2.3	2.2 2.3	mA mA		
		State: Core = MEASURE		●	5.7 5.5	6.2 6.2	6.6 6.8	mA mA		
		$I_{\text{REG(isoSPI)}}$	Additional V_{REG} Supply Current If isoSPI in READY/ACTIVE States Note: ACTIVE State Current Assumes $t_{\text{CLK}} = 1\mu\text{s}$, (Note 3)	LTC6810-2: ISOMD = 1, $R_{\text{B1}} + R_{\text{B2}} = 2\text{k}$	READY	●	3.6	4.5	5.4	mA
					ACTIVE	●	4.6	5.8	7.0	mA
LTC6810-1: ISOMD = 0, $R_{\text{B1}} + R_{\text{B2}} = 2\text{k}$	READY			●	3.6	4.5	5.2	mA		
	ACTIVE			●	5.6	6.8	8.1	mA		
LTC6810-1: ISOMD = 1, $R_{\text{B1}} + R_{\text{B2}} = 2\text{k}$	READY			●	4.0	5.2	6.5	mA		
	ACTIVE			●	7.0	8.5	10.5	mA		
LTC6810-2: ISOMD = 1, $R_{\text{B1}} + R_{\text{B2}} = 20\text{k}$	READY			●	1.0	1.8	2.6	mA		
	ACTIVE			●	1.2	2.2	3.2	mA		
LTC6810-1: ISOMD = 0, $R_{\text{B1}} + R_{\text{B2}} = 20\text{k}$	READY			●	1.0	1.8	2.6	mA		
	ACTIVE			●	1.3	2.3	3.3	mA		
LTC6810-1: ISOMD = 1, $R_{\text{B1}} + R_{\text{B2}} = 20\text{k}$	READY			●	1.6	2.5	3.5	mA		
	ACTIVE			●	1.8	3.1	4.8	mA		

Rev. B

ELECTRICAL CHARACTERISTICS The ● denotes the specifications which apply over the full operating temperature range, otherwise specifications are at $T_A = 25^\circ\text{C}$. The test conditions are $V^+ = 19.8\text{V}$, $V_{\text{REG}} = 5.0\text{V}$ unless otherwise noted. The ISOMD pin is tied to the V^- pin, unless otherwise noted.

SYMBOL	PARAMETER	CONDITIONS	MIN	TYP	MAX	UNITS
	V^+ Supply Voltage	TME Specifications Met	● 5.0	20	27.5	V
	V^+ to C6 Voltage	TME Specifications Met	● -0.3			V
V_{REG}	V_{REG} Supply Voltage	TME Supply Rejection < 1mV/V	● 4.5	5	5.5	V
	Internal Regulator Voltage	DRIVE Pin Current > 25 μA	● 4.5	4.6	4.8	V
	Allowed V_{REG} Range When Externally Driven	DRIVE Pin Is High Z	● 4.7	5	5.3	V
V_{DRIVE}	DRIVE Output Voltage	$V^+ > 12\text{V}$, Sourcing 1 μA	● 5.5	5.7	6.2	V
		$V^+ > 12\text{V}$, Sourcing 1mA	● 5.3	5.5	6	V
	Drive Pin Current to Enable Internal V_{REGA}		● 25			μA
	Maximum DRIVE Pin Current that Does Not Power Up Internal V_{REGA}		●		1	μA
V_{REGD}	Digital Supply Voltage		● 2.7	3	3.6	V
	Discharge Switch ON Resistance	$V_{\text{CELL}} = 3.3\text{V}$	●	5	10	Ω
	Thermal Shutdown Temperature			150		$^\circ\text{C}$
$V_{\text{OL(WDT)}}$	Watch Dog Timer (WDT) Pin Voltage	WDT Pin Sinking 4mA	●		0.4	V
$V_{\text{OL(GPIO)}}$	General Purpose I/O Pin Low	GPIO Pin Sinking 4mA (Used as Digital Output)	●		0.4	V

ADC Timing Specifications

t_{CYCLE} (Figure 6)	Measurement + Calibration Cycle Time When Starting from the REFUP State in Normal Mode, SCONV = 0, MCAL = 0	Measure 6 Cells	● 1098	1165	1281	μs	
		Measure 1 Cells	● 381	404	444	μs	
		Measure 6 Cells and 2 GPIO Inputs	● 1411	1497	1647	μs	
	Measurement + Calibration Cycle Time When Starting from the REFUP State in Filtered Mode, SCONV = 0, MCAL = 0	Measure 6 Cells	● 172	183	201	ms	
		Measure 1 Cells	● 31	34	37	ms	
		Measure 6 Cells and 2 GPIO Inputs	● 228	242	267	ms	
	Measurement + Calibration Cycle Time When Starting from the REFUP State in Fast Mode, SCONV = 0, MCAL = 0	Measure 6 Cells	● 495	524	577	μs	
		Measure 1 Cells	● 189	200	220	μs	
		Measure 6 Cells and 2 GPIO Inputs	● 643	682	750	μs	
t_{SKEW1} (Figure 9)	Skew Time. The Time Difference Between C6 and GPIO1 Measurements, Command = ADCVAX	Fast Mode	● 182	194	214	μs	
		Normal Mode	● 511	543	598	μs	
t_{SKEW2} (Figure 6)	Skew Time. The Time Difference Between C6 and C1 Measurements, Command = ADCV	Fast Mode	● 220	233	257	μs	
		Normal Mode	● 631	670	737	μs	
t_{WAKE}	Drive Start-Up Time (Note 5)	V_{REG} Generated from Drive Pin, See Figure 3	●	150	300	μs	
	Internal Regulator Start-Up Time	V_{REG} Generated Internally, See Figure 2	●	200	400	μs	
t_{SLEEP} (Figure 17)	Watchdog or Discharge Timer	DTEN Pin = 0 or DCTO[3:0] = 0000	● 1.8	2	2.2	sec	
		DTEN Pin = 1 and DCTO[3:0] = 0001		28	30	32	sec
		DTEN Pin = 1 and DCTO[3:0] = 1111		112	120	128	min
t_{REFUP} (Figure 6, Figure 30)	Reference Wake-up Time. Added to t_{CYCLE} Time When Starting from the STANDBY State. $t_{\text{REFUP}} = 0$ When Starting from Other States.	t_{REFUP} Is Independent of the Number of Channels Measured and the ADC Mode	● 2.7	3.5	4.4	ms	
f_{S}	ADC Clock Frequency		3.0	3.3	3.5	MHz	

LTC6810-1/LTC6810-2

ELECTRICAL CHARACTERISTICS The ● denotes the specifications which apply over the full operating temperature range, otherwise specifications are at $T_A = 25^\circ\text{C}$. The test conditions are $V^+ = 19.8\text{V}$, $V_{\text{REG}} = 5.0\text{V}$ unless otherwise noted. The ISOMD pin is tied to the V^- pin, unless otherwise noted.

SYMBOL	PARAMETER	CONDITIONS	MIN	TYP	MAX	UNITS
SPI Interface DC Specifications						
$V_{\text{IH(SPI)}}$	SPI Pin Digital Input Voltage High	Pins CSB, SCK, SDI	●	2.3		V
$V_{\text{IL(SPI)}}$	SPI Pin Digital Input Voltage Low	Pins CSB, SCK, SDI	●		0.8	V
$V_{\text{IH(ADDR)}}$	Address Pin Digital Input Voltage High	Pins ISOMD, DTEN, GPIO1 to GPIO4, A0–A3	●	2.7		V
$V_{\text{IL(ADDR)}}$	Address Pin Digital Input Voltage Low	Pins ISOMD, DTEN, GPIO1 to GPIO4, A0–A3	●		1.2	V
$I_{\text{LEAK(DIG)}}$	Digital Input Current	Pins CSB, SCK, SDI, ISOMD, DTEN, A0 to A3	●		± 1	μA
$V_{\text{OL(SDO)}}$	Digital Output Low	Pins SDO sinking 1mA	●		0.3	V
isoSPI DC Specifications (see Figure 23)						
V_{BIAS}	Voltage on IBIAS Pin	READY/ACTIVE State IDLE State	●	1.9	2 0	2.1 V
I_{B}	Isolated Interface Bias Current	$I_{\text{B}} = V_{\text{BIAS}} / (R_{\text{B1}} + R_{\text{B2}})$	●	0.1		1 mA
A_{IB}	Isolated Interface Current Gain	$V_{\text{A}} \leq 1.6\text{V}$ $I_{\text{B}} = 1\text{mA}$	●	18	20	22 mA/mA
		$I_{\text{B}} = 0.1\text{mA}$	●	18	20	23 mA/mA
V_{A}	Transmitter Pulse Amplitude	$V_{\text{A}} = V_{\text{IP}} - V_{\text{IM}} $	●			1.6 V
V_{ICMP}	Threshold-Setting Voltage on ICMP Pin	$V_{\text{TCMP}} = A_{\text{TCMP}} \cdot V_{\text{ICMP}}$	●	0.2		1.5 V
$I_{\text{LEAK(ICMP)}}$	Input Leakage Current on ICMP Pin		●			± 1 μA
$I_{\text{LEAK(IP/IM)}}$	Leakage Current on IP and IM Pins	IDLE State, V_{IP} or V_{IM} , 0V to V_{REG}	●			± 1 μA
A_{TCMP}	Receiver Comparator Threshold Voltage Gain	$V_{\text{CM}} = 2.5\text{V to } V_{\text{REG}} - 0.2$	●	0.4	0.5	0.6 V/V
V_{CM}	Receiver Common-Mode Bias	IP/IM Not Driving				$(V_{\text{REG}} - V_{\text{ICMP}}/3 - 167\text{mV})$ V
R_{IN}	Receiver Input Resistance	Single-Ended to IPA, IMA, IPB, IMB	●	26	35	45 k Ω
isoSPI Idle/Wake-up Specifications (see Figure 30)						
V_{WAKE}	Differential Wake-up Voltage	$V_{\text{WAKE}} = V_{\text{IPA}} - V_{\text{IMA}} $	●	250		mV
t_{DWELL}	Dwell Time at V_{WAKE} Before Wake Detection		●	240		ns
t_{READY}	Start-Up Time After Wake Detection		●			10 μs
t_{IDLE}	Idle Timeout Duration		●	4.3	5.5	6.7 ms
isoSPI Pulse Timing Specifications (see Figure 28)						
$t_{\frac{1}{2}\text{PW(CS)}}$	Chip-Select Half-Pulse Width	Transmitter	●	120	150	180 ns
$t_{\text{FILT(CS)}}$	Chip-Select Signal Filter	Receiver	●	70	90	110 ns
$t_{\text{INV(CS)}}$	Chip-Select Pulse Inversion Delay	Transmitter	●	120	155	190 ns
$t_{\text{WNDW(CS)}}$	Chip-Select Valid Pulse Window	Receiver	●	220	270	330 ns
$t_{\frac{1}{2}\text{PW(D)}}$	Data Half-Pulse Width	Transmitter	●	40	50	60 ns
$t_{\text{FILT(D)}}$	Data Signal Filter	Receiver	●	10	25	35 ns
$t_{\text{INV(D)}}$	Data Pulse Inversion Delay	Transmitter	●	40	55	65 ns
$t_{\text{WNDW(D)}}$	Data Valid Pulse Window	Receiver	●	70	90	110 ns

ELECTRICAL CHARACTERISTICS The ● denotes the specifications which apply over the full operating temperature range, otherwise specifications are at $T_A = 25^\circ\text{C}$. The test conditions are $V^+ = 19.8\text{V}$, $V_{\text{REG}} = 5.0\text{V}$ unless otherwise noted. The ISOMD pin is tied to the V^- pin, unless otherwise noted.

SYMBOL	PARAMETER	CONDITIONS	MIN	TYP	MAX	UNITS	
SPI Timing Requirements (see Figure 22 and Figure 29)							
t_{CLK}	SCK Period	(Note 6)	●	1		μs	
t_1	SDI Setup Time Before SCK Rising Edge		●	25		ns	
t_2	SDI Hold Time After SCK Rising Edge		●	25		ns	
t_3	SCK Low	$t_{\text{CLK}} = t_3 + t_4 \geq 1\mu\text{s}$	●	200		ns	
t_4	SCK High	$t_{\text{CLK}} = t_3 + t_4 \geq 1\mu\text{s}$	●	200		ns	
t_5	$\overline{\text{CS}}$ Rising Edge to $\overline{\text{CS}}$ Falling Edge		●	0.6		μs	
t_6	SCK Rising Edge to $\overline{\text{CS}}$ Rising Edge	(Note 6)	●	0.8		μs	
t_7	$\overline{\text{CS}}$ Falling Edge to SCK Rising Edge	(Note 6)	●	1		μs	
isoSPI Timing Specifications (see Figure 29)							
t_8	SCK Falling Edge to SDO Valid	(Note 7)	●		60	ns	
t_9	SCK Rising Edge to Short ± 1 Transmit		●		50	ns	
t_{10}	$\overline{\text{CS}}$ Transition to Long ± 1 Transmit		●		60	ns	
t_{11}	$\overline{\text{CS}}$ Rising Edge to SDO Rising	(Note 7)	●		200	ns	
t_{RTN}	Data Return Delay		●	325	375	425	ns
$t_{\text{DSY}(\text{CS})}$	Chip-Select Daisy-Chain Delay		●	120	180	ns	
$t_{\text{DSY}(\text{D})}$	Data Daisy-Chain Delay		●	200	250	300	ns
t_{LAG}	Data Daisy-Chain Lag (vs. Chip-Select)	$= [t_{\text{DSY}(\text{D})} + t_{\frac{1}{2}\text{PW}(\text{D})}] - [t_{\text{DSY}(\text{CS})} + t_{\frac{1}{2}\text{PW}(\text{CS})}]$	●	0	55	70	ns
$t_{5(\text{GOV})}$	Chip-Select High-to-Low Pulse Governor		●	0.6	0.82	μs	
$t_{6(\text{GOV})}$	Data to Chip-Select Pulse Governor		●	0.8	1.05	μs	
t_{BLOCK}	isoSPI Port Reversal Blocking Window		●	2	10	μs	

Note 1: Stresses beyond those listed under Absolute Maximum Ratings may cause permanent damage to the device. Exposure to any Absolute Maximum Rating condition for extended periods may affect device reliability and lifetime.

Note 2: The ADC specifications are guaranteed by the Total Measurement Error specification.

Note 3: S pin TME may differ from C pin TME by several bits due to the quantization noise of the ADC and the different external filtering on the C and S pins.

Note 4: The ACTIVE state current is calculated from DC measurements. The ACTIVE state current is the additional average supply current into V_{REG} when there is continuous 1MHz communications on the isoSPI ports with 50% data 1s and 50% data 0s. Slower clock rates reduce the supply current. See Applications Information section for additional details.

Note 5: V_{REG} is generated from the Drive pin and an external NPN transistor, see Figure 3.

Note 6: These timing specifications are dependent on the delay through the cable, and include allowances for 50ns of delay each direction. 50ns corresponds to 10m of CAT-5 cable (which has a velocity of propagation of 66% the speed of light). Use of longer cables would require derating these specs by the amount of additional delay.

Note 7: These specifications do not include rise or fall time of SDO. While fall time (typically 5ns due to the internal pull-down transistor) is not a concern, rising-edge transition time t_{RISE} is dependent on the pull-up resistance and load capacitance on the SDO pin. The time constant must be chosen such that SDO meets the setup time requirements of the MCU.

TYPICAL PERFORMANCE CHARACTERISTICS $T_A = 25^\circ\text{C}$, unless otherwise noted.

Measurement Error vs Temperature

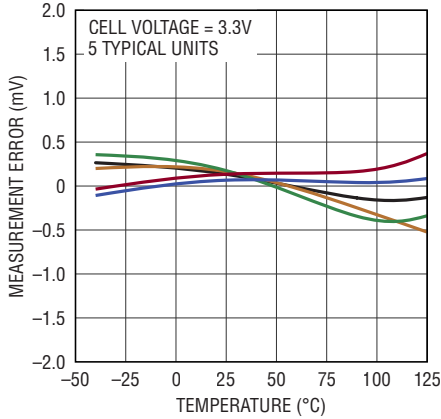

Measurement Error Due to IR Reflow

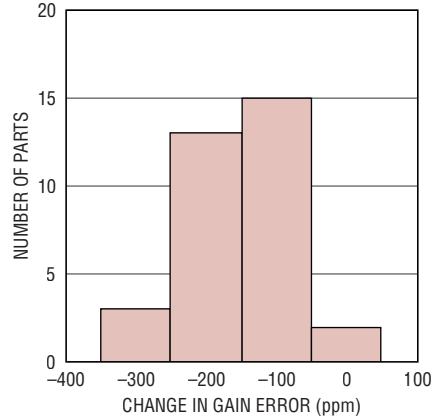

Measurement Error Long Term Drift

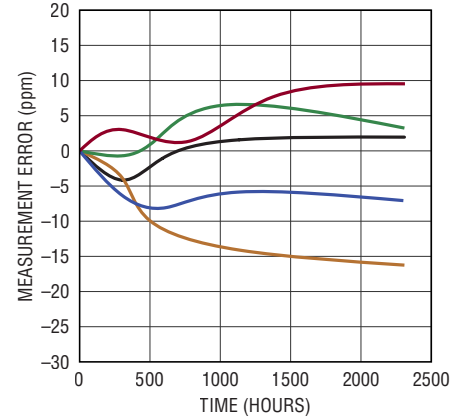

Measurement Error vs Input Normal Mode

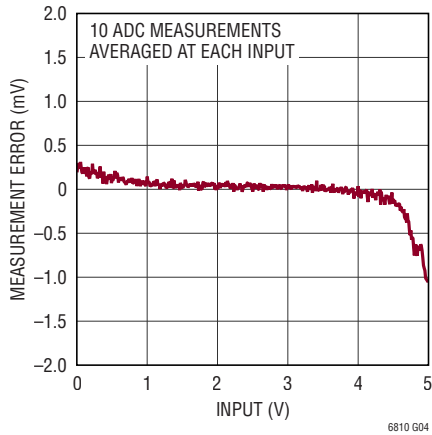

Measurement Error vs Input Filtered Mode

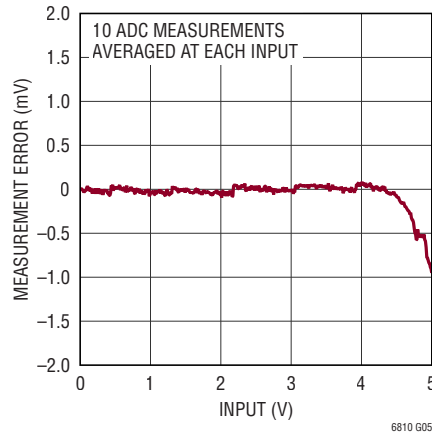

Measurement Error vs Input Fast Mode

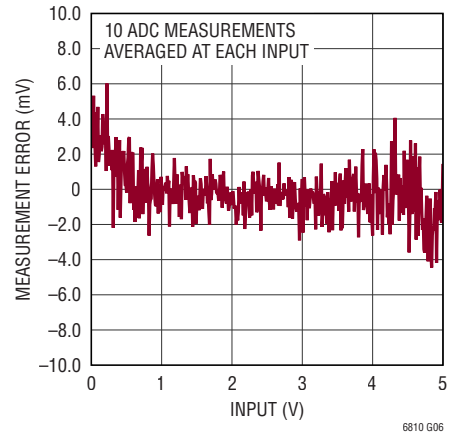

Measurement Noise vs Input Normal Mode

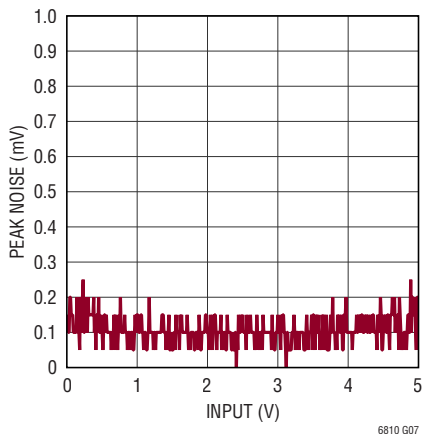

Measurement Noise vs Input Filtered Mode

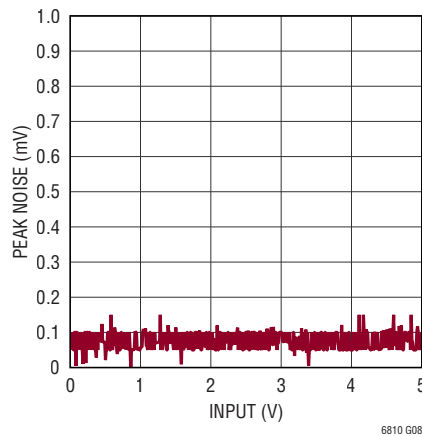

Measurement Noise vs Input Fast Mode

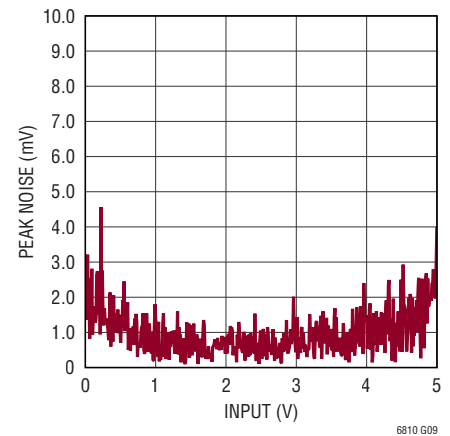

TYPICAL PERFORMANCE CHARACTERISTICS $T_A = 25^\circ\text{C}$, unless otherwise noted.

Measurement Gain Error Hysteresis, Hot

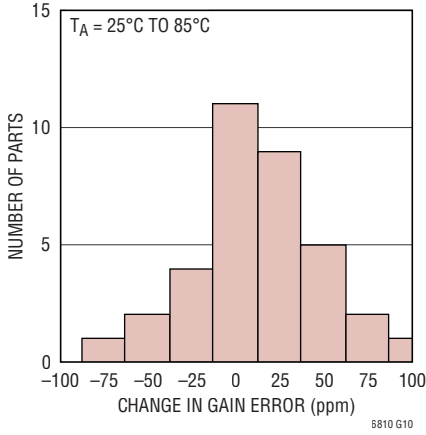

Measurement Gain Error Hysteresis, Cold

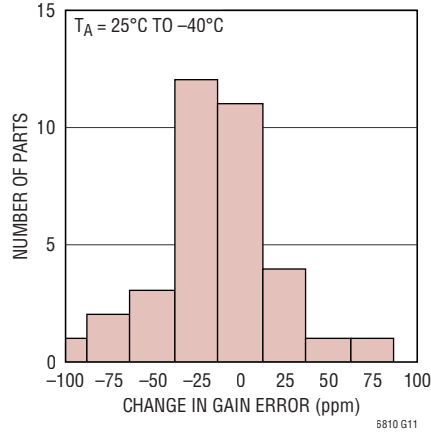

Noise Filter Response

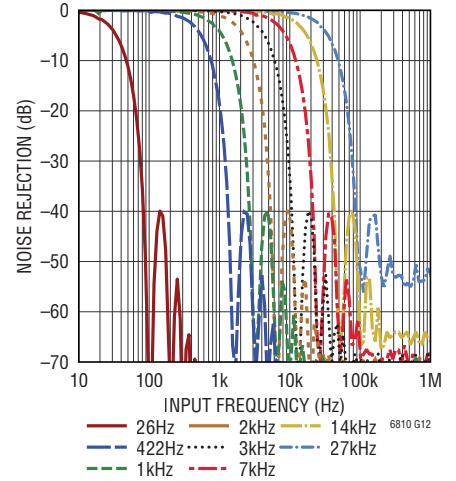

Measurement Error vs V_{REG}

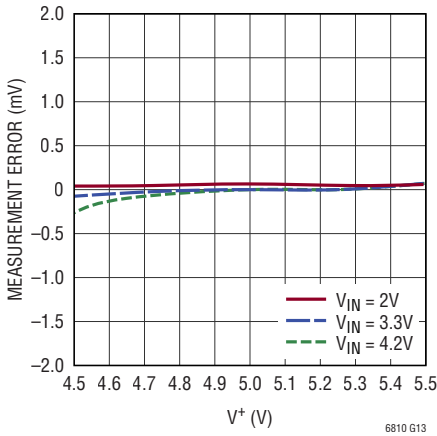

Measurement Error vs V^+

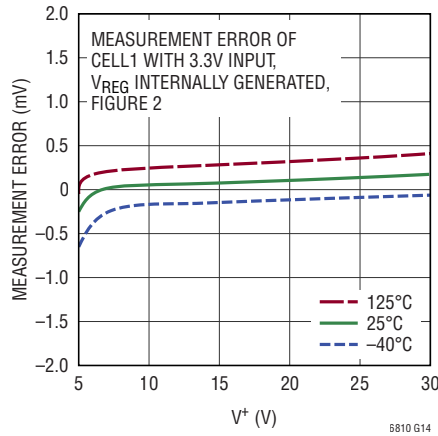

Top Cell Measurement Error vs V^+

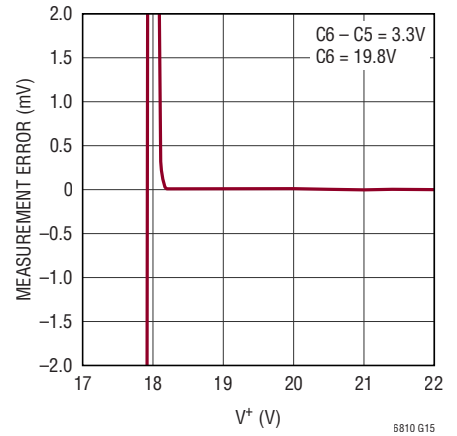

Measurement Error vs Common Mode Voltage

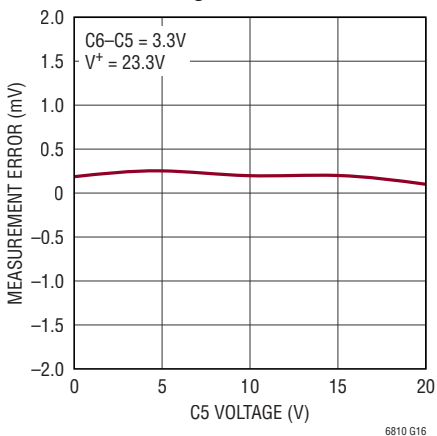

Measurement Error Due to a V_{REG} AC Disturbance

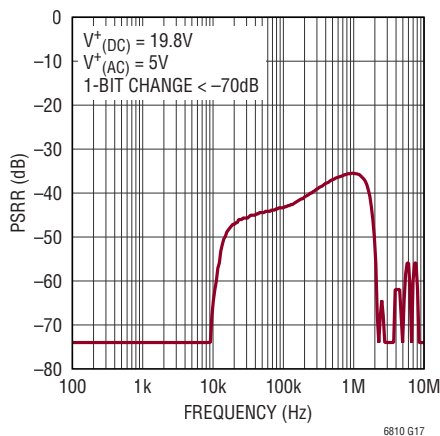

Measurement Error Due to a V^+ AC Disturbance

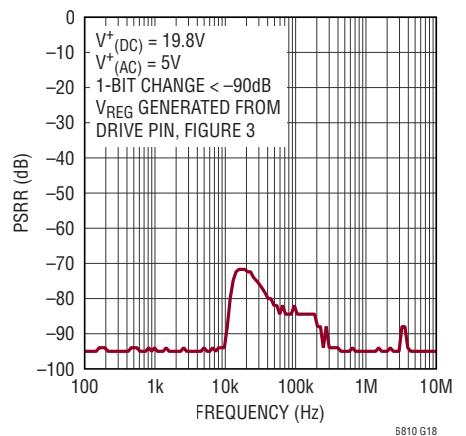

LTC6810-1/LTC6810-2

TYPICAL PERFORMANCE CHARACTERISTICS $T_A = 25^\circ\text{C}$, unless otherwise noted.

Measurement Error CMRR vs Frequency

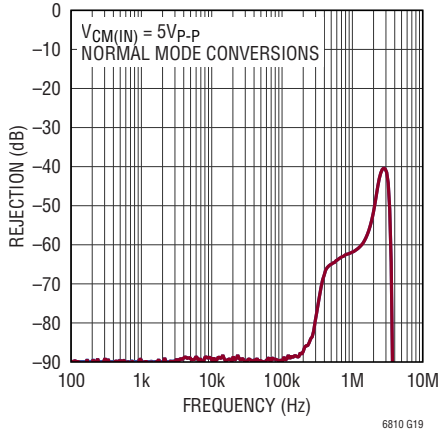

Cell Measurement Error vs Input RC Values

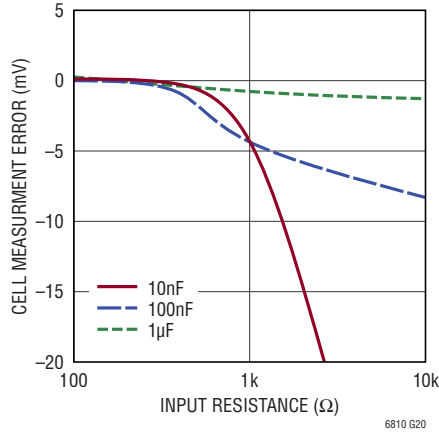

GPIO Measurement Error vs Input RC Values

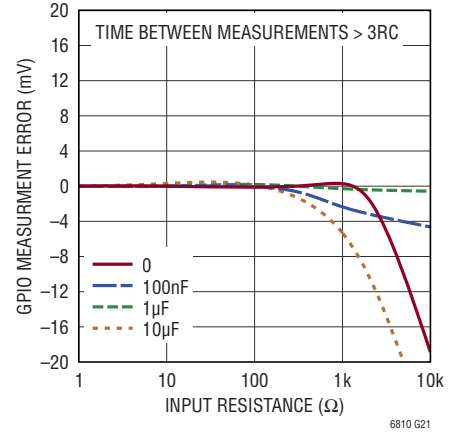

Measurement Time vs Temperature

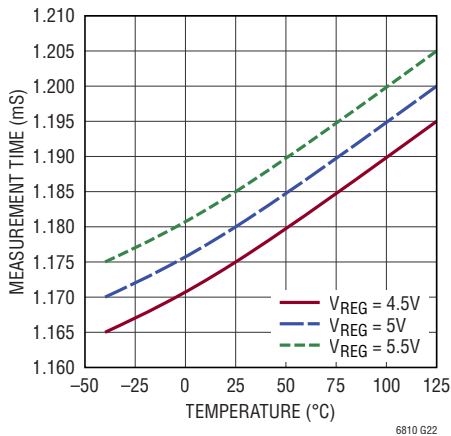

Sleep Mode Supply Current vs V+

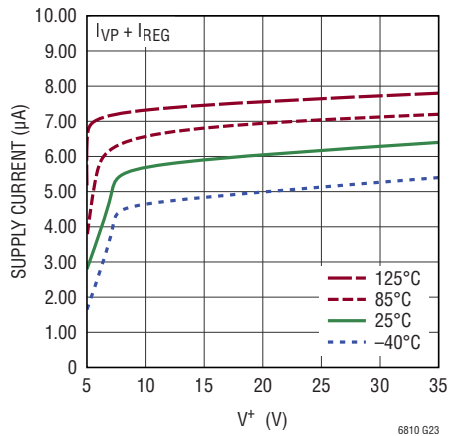

Standby Supply Current vs V+ Internal REG Enabled

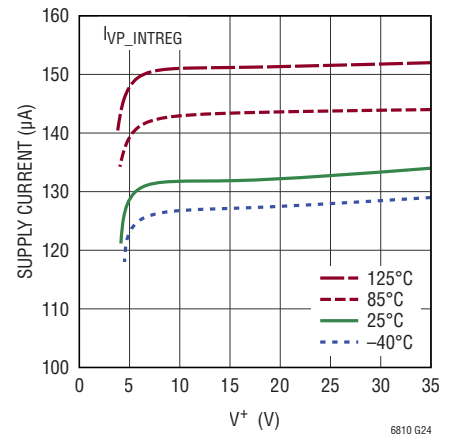

Standby Supply Current vs V+ Internal REG Disabled

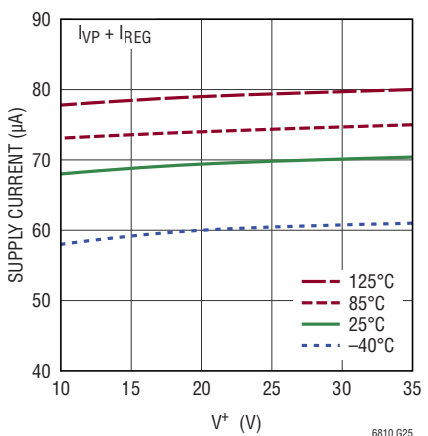

REFUP Supply Current vs V+ Internal REG Disabled

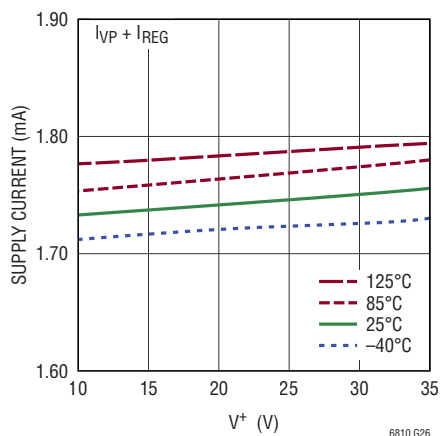

Measure Supply Current vs V+ Internal REG Disabled

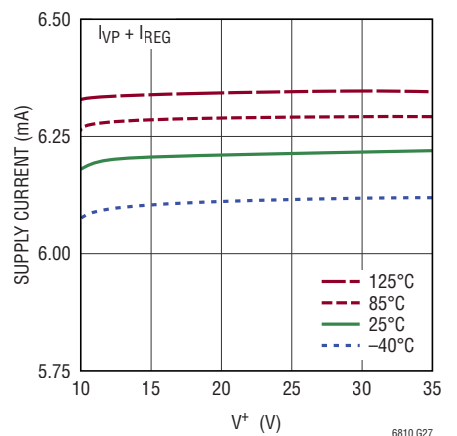

TYPICAL PERFORMANCE CHARACTERISTICS $T_A = 25^\circ\text{C}$, unless otherwise noted.

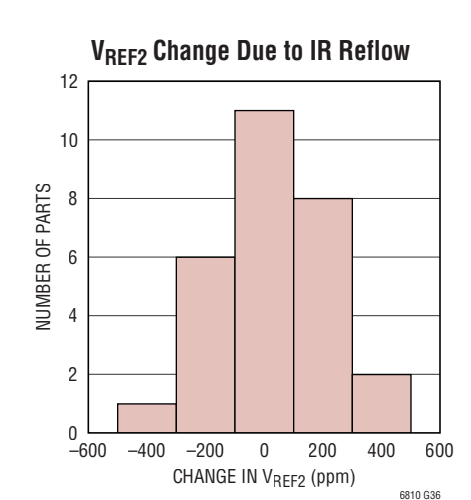
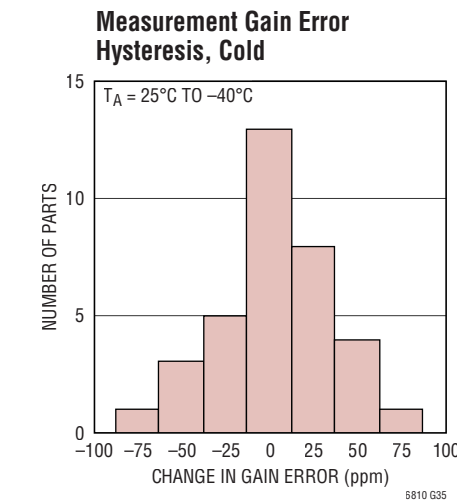
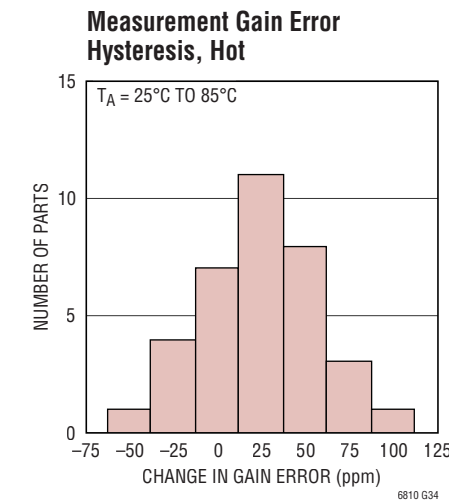
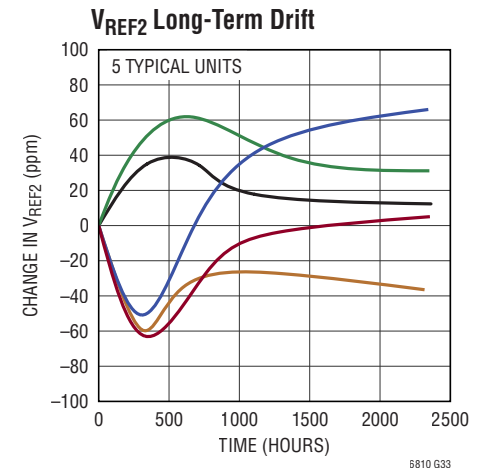
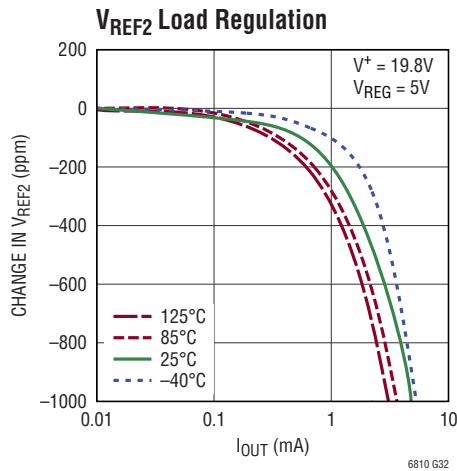
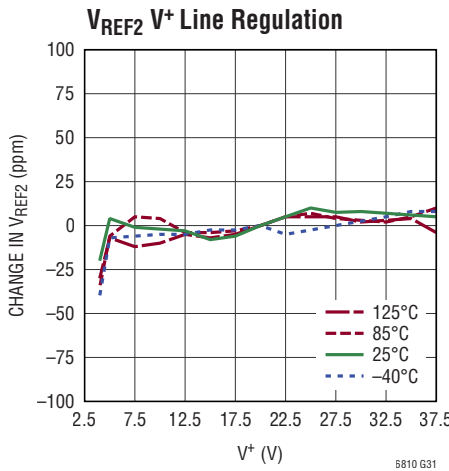
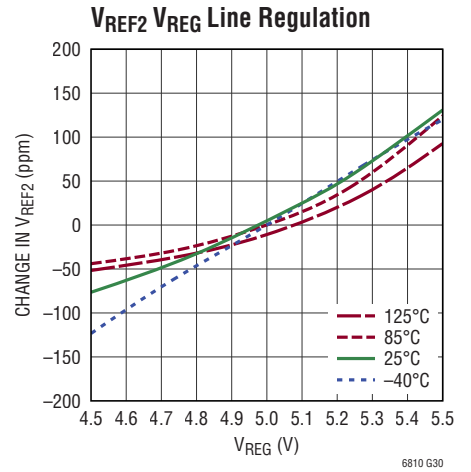
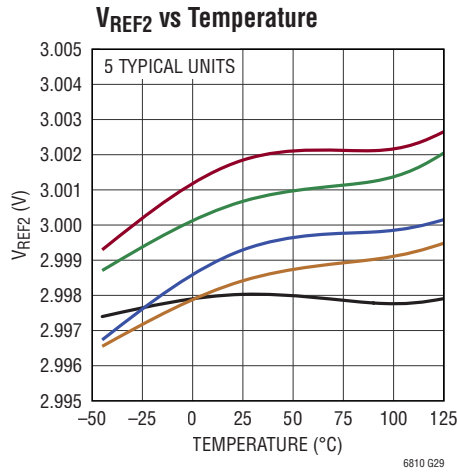
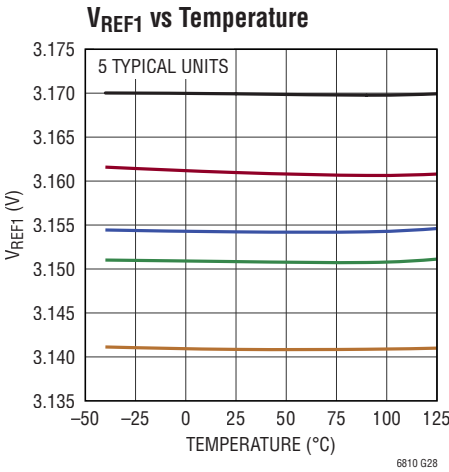

TYPICAL PERFORMANCE CHARACTERISTICS $T_A = 25^\circ\text{C}$, unless otherwise noted.

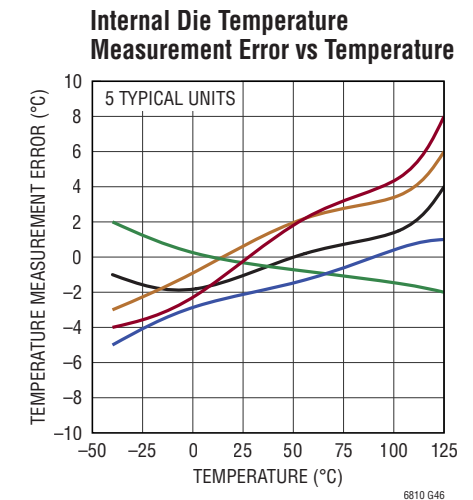
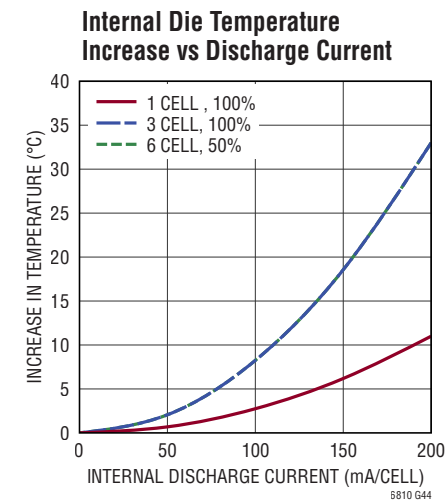
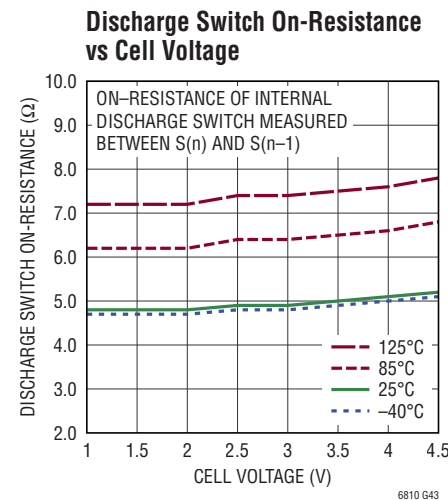
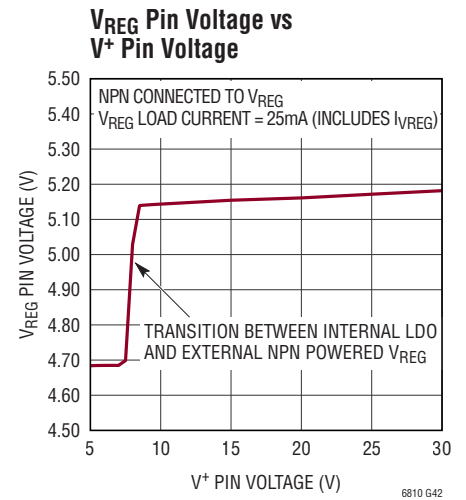
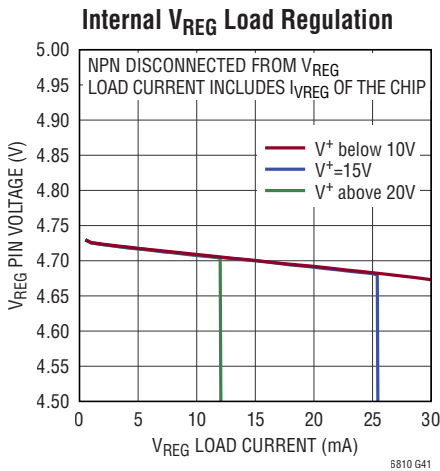
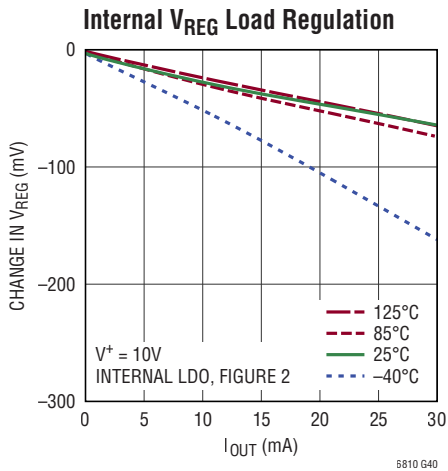
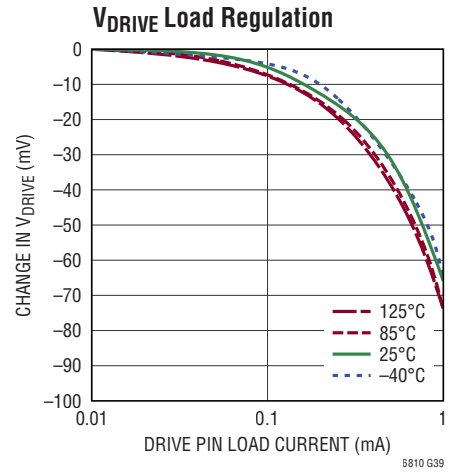
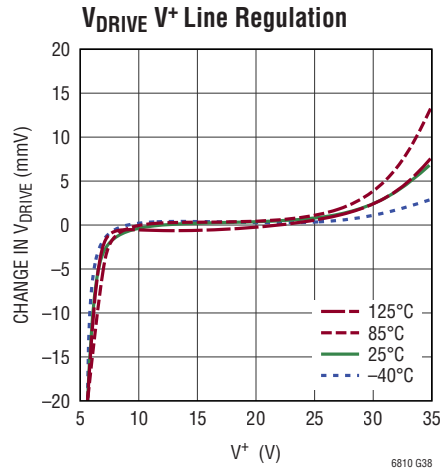
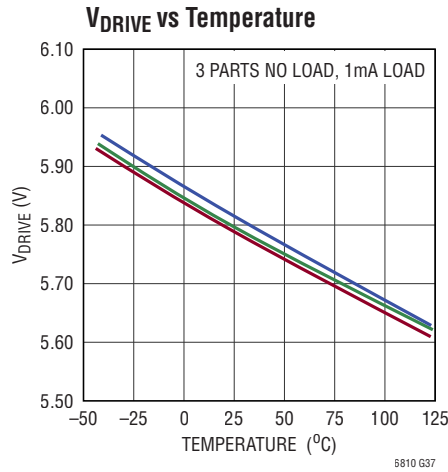

TYPICAL PERFORMANCE CHARACTERISTICS $T_A = 25^\circ\text{C}$, unless otherwise noted.

V_{REF1} and V_{REF2} Power-Up

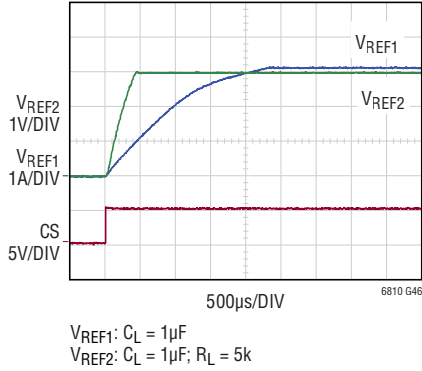

V_{REG} and V_{DRIVE} Power-Up

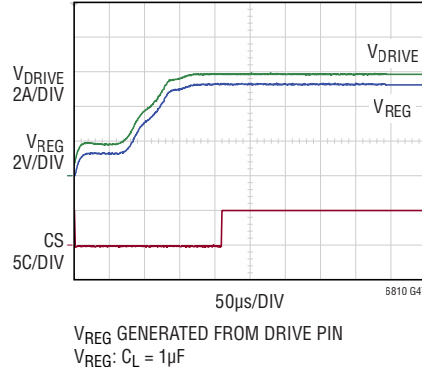

isoSPI Current (READY) vs Temperature

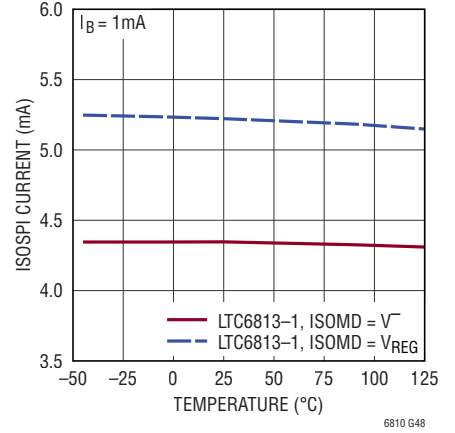

isoSPI Current (ACTIVE) vs isoSPI Clock Frequency

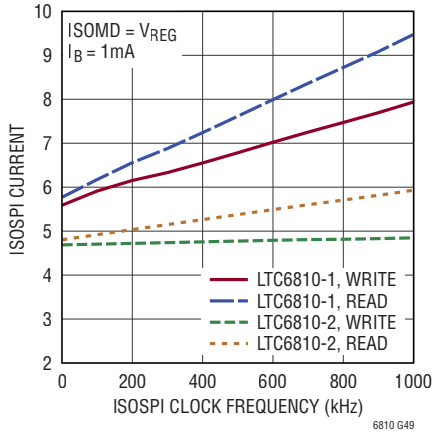

IBIAS Voltage vs Temperature

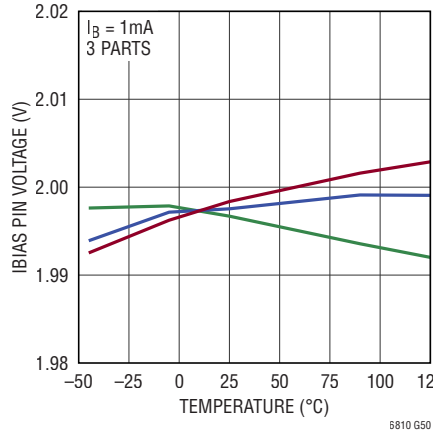

IBIAS Voltage Load Regulation

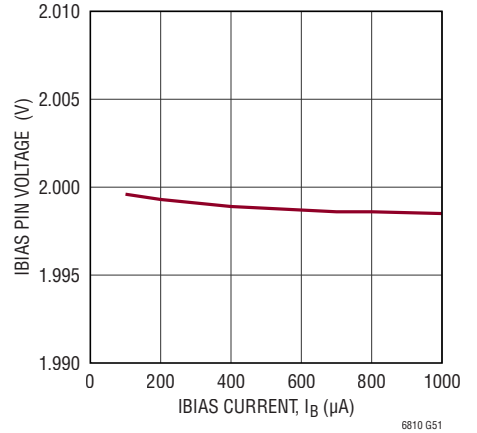

isoSPI Driver Current Gain (Port A/Port B) vs IBIAS Current

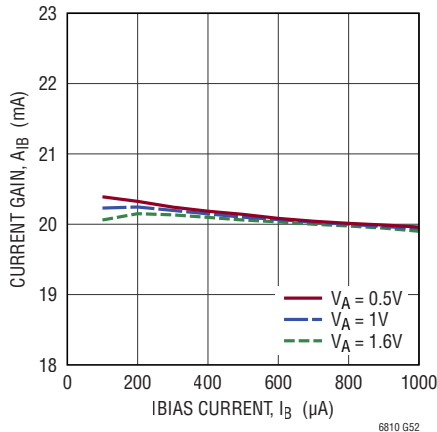

isoSPI Driver Current Gain (Port A/Port B) vs Temperature

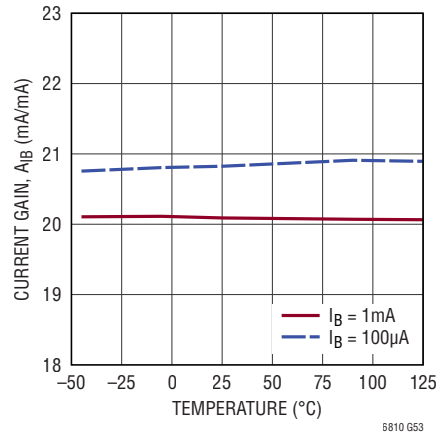

TYPICAL PERFORMANCE CHARACTERISTICS $T_A = 25^\circ\text{C}$, unless otherwise noted.

isoSPI Driver Common Mode Voltage (Port A/Port B) vs Pulse Amplitude

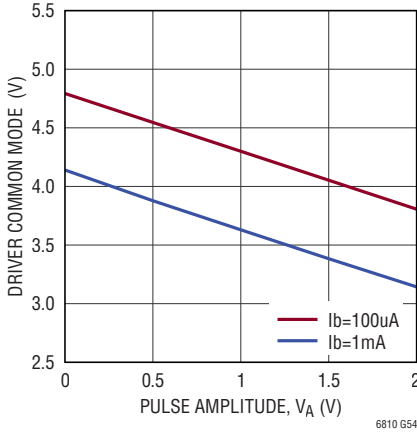

isoSPI Comparator Threshold Gain (Port A/Port B) vs Receiver Common Mode

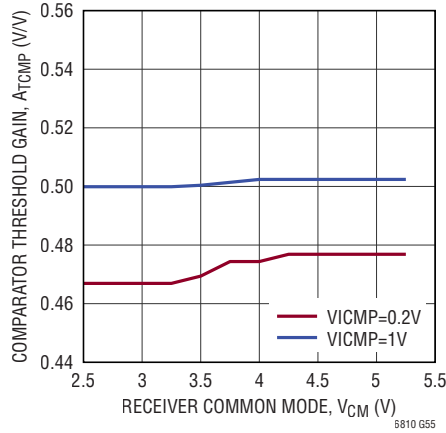

isoSPI Comparator Threshold Gain (Port A/Port B) vs ICMP Voltage

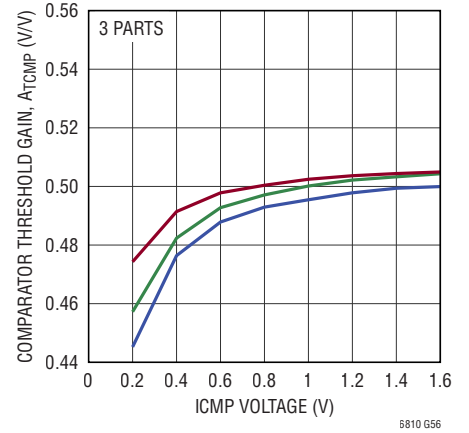

isoSPI Comparator Threshold Gain (Port A/Port B) vs Temperature

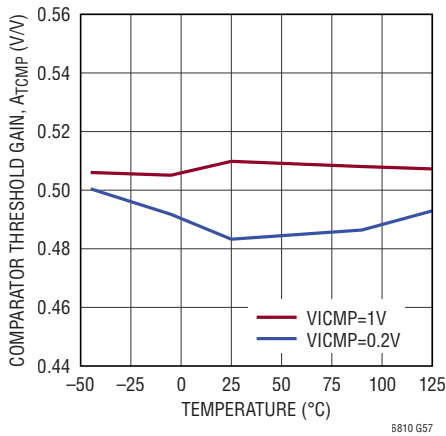

Typical Wake-Up Pulse Amplitude (Port A/Port B) vs Dwell Time

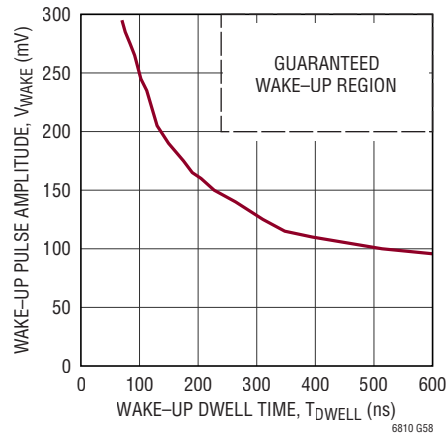

PIN FUNCTIONS

C0 – C6: Cell Inputs.

S0 – S6: Balance Inputs/Outputs Redundant Cell Measurement. 6 NMOSFETs are connected between S(n) and S(n–1) for discharging cells. Additionally S pins can be used for redundant cell measurement.

V⁺: Positive Supply Pin.

V⁻: Negative Supply Pins. The V⁻ pins must be shorted together, external to the IC.

V^{-*}: These pins are fused to the leadframe, connect to V⁻.

V_{REF2}: Buffered 2nd reference voltage for driving thermistors. Bypass with an external 1μF capacitor.

V_{REF1}: ADC Reference Voltage. Bypass with an external 1μF capacitor. No DC loads allowed.

GPIO[1:4]: General Purpose I/O. Can be used as digital inputs or digital outputs, or as analog inputs with a measurement range from V⁻ to 5V. GPIO[2:4] can be used as an I²C or SPI port.

DTEN: Discharge Timer Enable. Connect this pin to V_{REG} to enable the Discharge Timer.

DRIVE: Connect the base of an NPN to this pin. Connect the collector to V⁺ and the emitter to V_{REG}.

V_{REG}: 5V Regulator Input. Bypass with an external 1μF capacitor.

ISOMD: Serial Interface Mode. Connecting ISOMD to V_{REG} configures the LTC6810 for 2-wire isolated interface (isoSPI) mode. Connecting ISOMD to V⁻ configures the LTC6810 for 4-wire SPI mode.

WDT: Watchdog Timer Output Pin. This is an open drain NMOS digital output. It can be left unconnected, or connected with a 1M resistor to V_{REG}. If the LTC6810 does not receive a valid command within 2 seconds, the watchdog timer circuit will reset the LTC6810 and the WDT pin will go high impedance.

Serial Port Pins

	LTC6810-1 (DAISY-CHAINABLE)		LTC6810-2 (ADDRESSABLE)	
	ISOMD = V _{REG}	ISOMD = V ⁻	ISOMD = V _{REG}	ISOMD = V ⁻
PORT B (Pins 39, 38, 35 and 34)	IPB	IPB	A3	A3
	IMB	IMB	A2	A2
	ICMP	ICMP	A1	A1
	IBIAS	IBIAS	A0	A0
PORT A (Pins 40, 41, 37 and 36)	(NC)	SDO	IBIAS	SDO
	(NC)	SDI	ICMP	SDI
	IPA	SCK	IPA	SCK
	IMA	CSB	IMA	CSB

CSB, SCK, SDI, SDO: 4-Wire Serial Peripheral Interface (SPI). Active low chip select (CSB), serial clock (SCK), serial data in (SDI), are digital inputs. Serial data out (SDO) is an open drain NMOS output. SDO requires a 5K pull-up resistor

A0–A3: Address Pins. These digital inputs are connected to V_{REG} or V⁻ to set the chip address for addressable serial commands.

IPA, IMA: Isolated 2-Wire Serial Interface Port A. IPA (plus) and IMA (minus) are a differential input/output pair.

IPB, IMB: Isolated 2-Wire Serial Interface Port B. IPB (plus) and IMB (minus) are a differential input/output pair.

IBIAS: Isolated Interface Current Bias. Tie IBIAS to V⁻ through a resistor divider to set the interface output current level. When the isoSPI interface is enabled, the IBIAS pin voltage is 2V. The IPA/IMA or IPB/IMB output current drive is set to 20 times the current, I_B, sourced from the IBIAS pin.

ICMP: Isolated Interface Comparator Voltage Threshold Set. Tie this pin to the resistor divider between IBIAS and V⁻ to set the voltage threshold of the isoSPI receiver comparators. The comparator thresholds are set to ½ the voltage on the ICMP pin.

LTC6810-1/LTC6810-2

BLOCK DIAGRAM

LTC6810-1

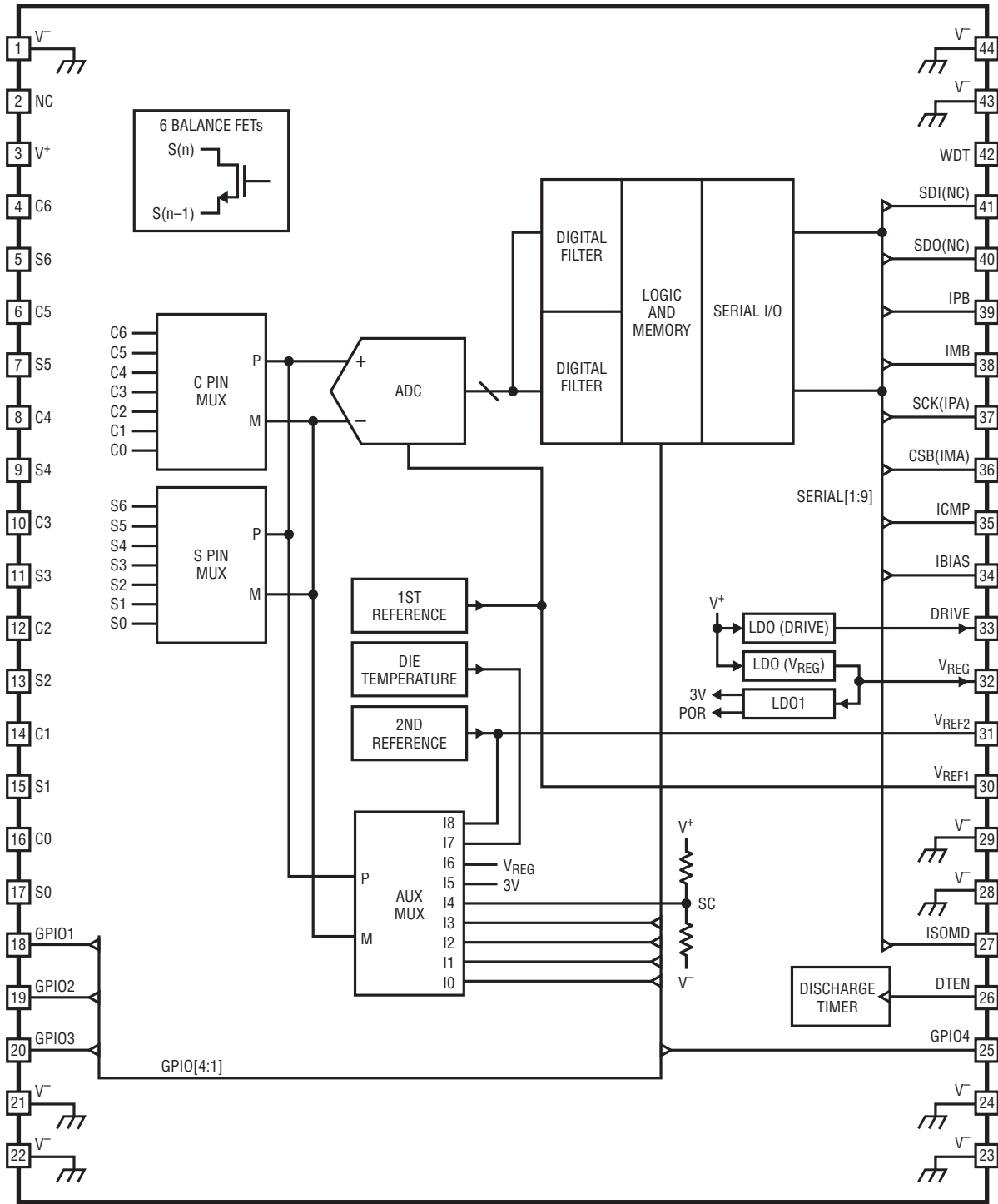

68101 BD1

BLOCK DIAGRAM

LTC6810-2

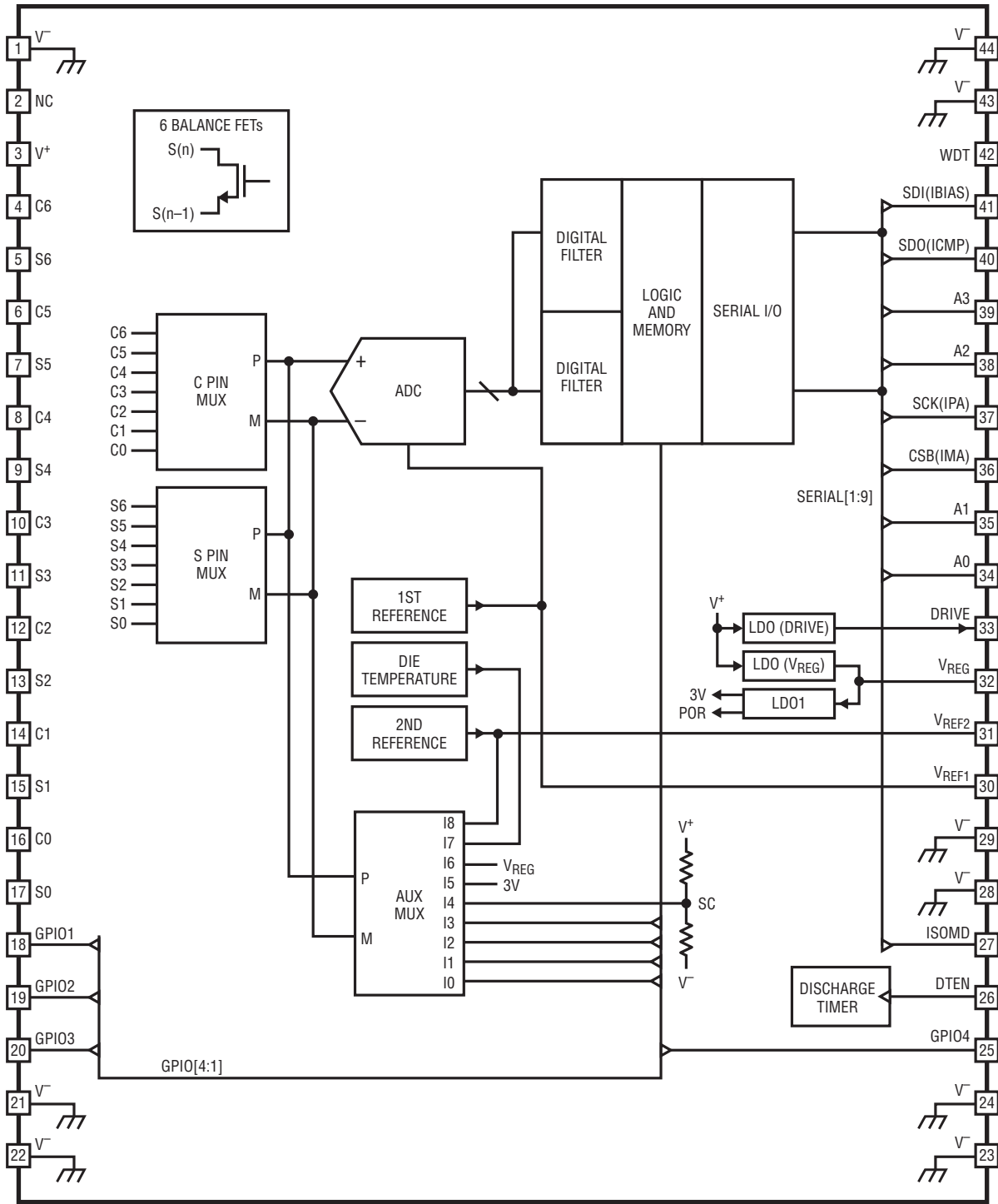

68101 BD2

OPERATION

STATE DIAGRAM

The operation of the LTC6810 is divided into two separate sections: the Core circuit and the isoSPI circuit. Both sections have an independent set of operating states, as well as a shutdown timeout.

CORE LTC6810 STATE DESCRIPTIONS

SLEEP State

The references and ADC modulator are powered down. The watchdog timer (see Watchdog and Discharge Timer) has timed out. The discharge timer is either disabled or timed out. The supply currents are reduced to minimum levels. The isoSPI ports will be in the IDLE state. The Drive pin is 0V. All state machines are reset to their default state

If a WAKEUP signal is received (see Waking Up the Serial Interface), the LTC6810 will enter the STANDBY state.

STANDBY State

The references and the ADC are off. The watchdog timer and/or the discharge timer is running. V_{REG} pin is powered to 5.2V through an external transistor controlled by the DRIVE pin. Alternatively, when V^+ is less than 12V, V_{REG} can be powered through the internal LDO to 4.7V. V_{REG} can also be powered through an external source. In

this case, the internal regulator must be disabled to avoid contention by floating the DRIVE pin. For more details see V_{REG} Configurations.

When a valid ADC command is received or the REFON bit is set to 1 in the Configuration Register Group, the IC pauses for t_{REFUP} to allow for the references to power up and then enters either the REFUP or MEASURE state. Otherwise, if no valid commands are received for t_{SLEEP} , the IC returns to the SLEEP state if DTEN = 0 or enters the EXTENDED BALANCING state if DTEN = 1.

REFUP State

To reach this state the REFON bit in the Configuration Register Group must be set to 1 (using the WRCFG command, see Table 40). The ADCs are off. The references are powered up so that the LTC6810 can initiate ADC conversions more quickly than from the STANDBY state.

When a valid ADC command is received, the IC goes to the MEASURE state to begin the conversion. Otherwise, the LTC6810 will return to the STANDBY state when the REFON bit is set to 0, (using WRCFG command). If no valid commands are received for t_{SLEEP} , the IC returns to the SLEEP state if DTEN = 0 or enters the EXTENDED BALANCING state if DTEN = 1

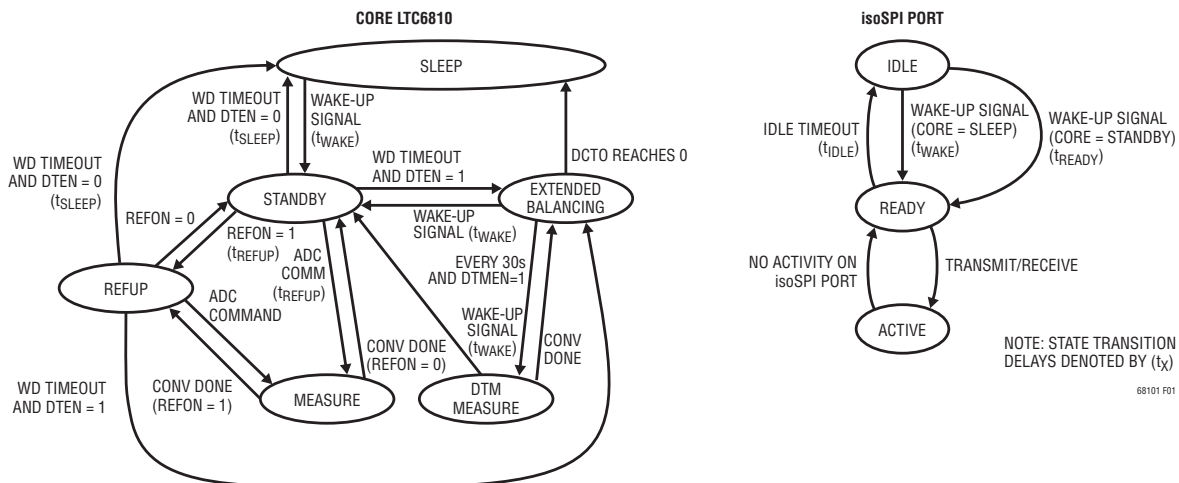

Figure 1. LTC6810 Operation State Diagram

OPERATION

MEASURE State

The LTC6810 performs ADC conversions in this state. The references and ADCs are powered up.

After ADC conversions are complete the LTC6810 will transition to either the REFUP or STANDBY states, depending on the REFON bit. Additional ADC conversions can be initiated more quickly by setting REFON = 1 to take advantage of the REFUP state.

Note: Non-ADC commands do not cause a Core state transition. Only an ADC Conversion or DIAGN command will place the Core in the MEASURE state.

EXTENDED BALANCING State

The watchdog timer has timed out, but the discharge timer has not yet timed out ($DTEN = 1$). Discharge by PWM may be in progress. If the Discharge Timer Monitor is enabled then the LTC6810 will transition to the DTM MEASURE state every 30 seconds to measure the cell voltages. If a WAKEUP signal is received, the LTC6810 will transition from EXTENDED BALANCING state to STANDBY state.

Discharge Timer Monitor MEASURE State

The watchdog timer has timed out but background monitoring has been enabled ($DTMEN = 1$ in the Configuration Register). The LTC6810 enters this state from the EXTENDED BALANCING state once every 30 seconds to measure the cell voltages. The LTC6810 is in the highest core power state and an A/D conversion is in progress. If a WAKEUP signal is received, the LTC6810 will transition from DTM MEASURE state to STANDBY state.

isoSPI STATE DESCRIPTIONS

Note: The LTC6810-1 has two isoSPI ports (A and B), for daisy-chain communication. The LTC6810-2 has only one isoSPI port (A), for parallel-addressable communication.

IDLE State

The isoSPI ports are powered down.

When isoSPI port A or port B (LTC6810-1 only) receives a WAKEUP signal (see Waking up the Serial Interface), the isoSPI enters the READY state. This transition happens quickly (within t_{READY}) if the Core is in the STANDBY state. If the Core is in the SLEEP state when the isoSPI receives a WAKEUP signal, the it transitions to the READY state within t_{WAKE} .

READY State

The isoSPI port(s) are ready for communication. Port B is enabled only for LTC6810-1, and is not present on the LTC6810-2. The serial interface current in this state depends on if the part is LTC6810-1 or LTC6810-2, the status of the ISOMD pin, and $R_{BIAS} = R_{B1} + R_{B2}$ (the external resistors tied to the I_{BIAS} pin).

If there is no activity (i.e. no WAKEUP signal) for greater than $t_{IDLE} = 5.5ms$, the LTC6810 goes to the IDLE state. When the serial interface is transmitting or receiving data the LTC6810 goes to the ACTIVE state.

ACTIVE State

The LTC6810 is transmitting/receiving data using one or both of the isoSPI ports. The serial interface consumes maximum power in this state. The supply current increases with clock frequency as the density of isoSPI pulses increases.

OPERATION

POWER CONSUMPTION

The LTC6810 is powered via two pins: V^+ and V_{REG} . The V^+ input requires voltage greater than or equal to the top cell voltage minus 0.3V, and it provides power to the high voltage elements of the core circuitry. The V_{REG} input requires 5V and provides power to the remaining core circuitry and the isoSPI circuitry.

The power consumption varies according to the operational states. The V_{REG} input can be powered through an external transistor that is driven by the regulated DRIVE output pin, through the internal LDO, or through an external supply. The internal LDO is powered from V^+ , so in this configuration V_{REG} current also comes from V^+ . Total V^+ current when using the internal LDO to power V_{REG} is given by,

$$I_{VP_INTREG} = I_{VP} + I_{REG}$$

I_{VP} current depends only on the Core state. However, I_{REG} current depends on both the Core state and isoSPI state, and can therefore be divided into two components. The isoSPI interface draws current only from the V_{REG} pin.

$$I_{REG} = I_{REG(Core)} + I_{REG(ISO SPI)}$$

Table 1 provides typical values for I_{VP} and $I_{REG(Core)}$ supply currents in each of the Core states. Table 2 provides equations to approximate $I_{REG(ISO SPI)}$ supply pin currents in each of the isoSPI states.

Table 1. Core Supply Current

STATE		I_{VP}	$I_{REG(Core)}$
SLEEP	$V_{REG} = 0V$	5.7 μ A	0 μ A
	$V_{REG} = 5V$	3.5 μ A	3.3 μ A
STANDBY, Int Regulator Enabled		75 μ A	55 μ A
STANDBY, Int Regulator Disabled		20 μ A	55 μ A
REFUP		30 μ A	1.7mA
MEASURE		50 μ A	6.1mA

Table 2. isoSPI Supply Current Equations

isoSPI STATE	ISOMD CONNECTION	$I_{REG(ISO SPI)}$
IDLE	N/A	0mA
READY	V_{REG}	$2.2mA + 3 \cdot I_B$
	V^-	$1.5mA + 3 \cdot I_B$
ACTIVE	V_{REG}	Write: $2.5mA + \left(3 + 20 \cdot \frac{100ns}{t_{CLK}}\right) \cdot I_B$ Read: $2.5mA + \left(3 + 20 \cdot \frac{100ns \cdot 1.5}{t_{CLK}}\right) \cdot I_B$
	V^-	$1.8mA + \left(3 + 20 \cdot \frac{100ns}{t_{CLK}}\right) \cdot I_B$

OPERATION

V_{REG} CONFIGURATIONS

This section describes the different configurations that can be used to power V_{REG} on the LTC6810. When V⁺ pin voltage is less than 12V, the DRIVE pin voltage drops below its nominal value as the regulator on the DRIVE pin does not have sufficient headroom. Under these conditions V_{REG} pin cannot be powered through an external transistor. To overcome this problem, LTC6810 has an internal LDO that powers the V_{REG} pin to 4.7V typically. The internal LDO can operate for V⁺ pin voltage as low as 5V. The internal LDO is enabled by applying a load current greater than 15μA on the DRIVE pin. Figure 2 shows a typical configuration for LTC6810 using the internal LDO when V⁺ is less than 12V. The suggested 100K resistor on the DRIVE pin draws a minimum of 30μA from the DRIVE pin. This keeps the internal regulator enabled.

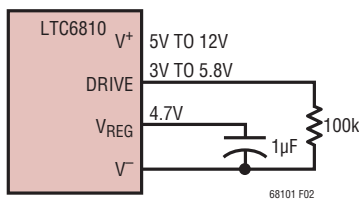

Figure 2. V_{REG} Powered by Internal LDO

The power dissipation across the pass transistor in the internal LDO is $(V^+ - V_{REG}) \cdot I_{REG}$. To limit the power dissipation inside the part it is recommended to power V_{REG} using an external transistor when V⁺ pin voltage is greater than 12V. The external transistor is driven by the regulated DRIVE pin voltage that sets V_{REG} pin voltage to 5.2V typically. The internal LDO is designed to only source current, so when V_{REG} pin is driven to 5.2V by the external transistor the internal regulator is gracefully shutdown.

Figure 3 shows a typical configuration for LTC6810 that uses an external transistor to power V_{REG}. Note that this configuration can still be used if V⁺ drops below 12V, but when V_{REG} pin voltage set by the external transistor drops below the internal LDO level, the internal LDO will take over and power V_{REG}.

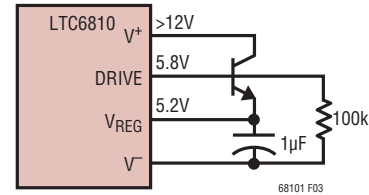

Figure 3. V_{REG} Powered by External Transistor

Alternatively, V_{REG} pin can also be powered from an external source. In this configuration, it is important to ensure that the internal LDO is always shutdown so there is no contention problem. This can be achieved by floating the DRIVE pin. Figure 4 shows a typical configuration for LTC6810 when V_{REG} is powered from an external source.

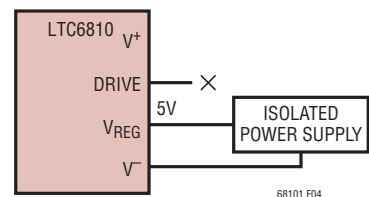

Figure 4. V_{REG} Powered by an Independent Supply

OPERATION

ADC OPERATION

There is one ADC inside the LTC6810. The ADC is used to measure the cell voltages via the C or S pins and general purpose inputs.

ADC Modes

The ADCOPT bit (CFGR0[0]) in the Configuration Register Group and the mode selection bits MD[1:0] in the conversion command together provide eight modes of operation for the ADC which correspond to different oversampling ratios (OSR). The accuracy and timing of these modes are summarized in Table 3. In each mode, the ADC first measures the inputs, and then performs a calibration. The names of the modes are based on the -3dB bandwidth of the ADC measurement.

Mode 7kHz (Normal Mode): In this mode, the ADC has high resolution and low TME (total measurement error). This is considered the normal operating mode because of the optimum combination of speed and accuracy.

Mode 27kHz (Fast Mode): In this mode, the ADC has maximum throughput but has some increase in TME (total measurement error). So this mode is also referred to as the fast mode. The increase in speed comes from a reduction in the oversampling ratio. This results in an increase in noise and average measurement error.

Mode 26Hz (Filtered Mode): In this mode, the ADC digital filter -3dB frequency is lowered to 26Hz by increasing the OSR. This mode is also referred to as the filtered mode due to its low -3dB frequency. The accuracy is similar to the 7kHz (normal) mode with lower noise.

Modes 14kHz, 3kHz, 2kHz, 1kHz and 422Hz: Modes 14kHz, 3kHz, 2kHz, 1kHz and 422Hz provide additional options to set the ADC digital filter -3dB at 13.5kHz, 3.4kHz, 1.7kHz, 845Hz and 422Hz respectively. The accuracy of the 14kHz mode is similar to the 27kHz (fast) mode. The accuracy of 3kHz, 2kHz, 1kHz and 422Hz modes is similar to the 7kHz (normal) mode.

The filter bandwidths and the conversion times for these modes are provided in Table 3 and Table 5. If the Core is

in STANDBY state, an additional t_{REFUP} time is required to power up the reference before beginning the ADC conversions. The reference can remain powered up between ADC conversions if the REFON bit in Configuration Register Group is set to 1 so the Core is in REFUP state after a delay t_{REFUP} . If REFON is set to 1 the Core will go from STANDBY to the REFUP state after a delay t_{REFUP} . Then, the subsequent ADC commands will not have the t_{REFUP} delay before beginning ADC conversions.

ADC Range and Resolution

The cell inputs and GPIO inputs have the same range and resolution. The ADC inside the LTC6810 has an approximate range from -0.82V to $+5.73\text{V}$. Negative readings are rounded to 0V. The format of the data is a 16-bit unsigned integer where the LSB represents $100\mu\text{V}$. Therefore, a reading of 0x80E8 (33,000 decimal) indicates a measurement of 3.3V.

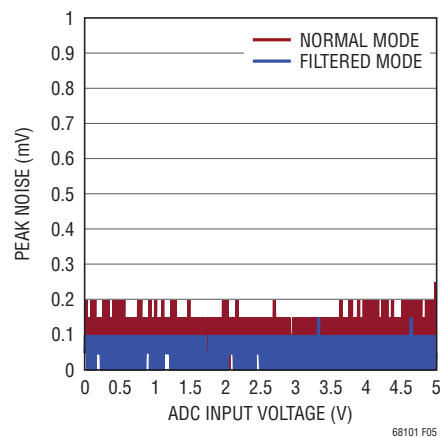

Figure 5.

Delta-Sigma ADCs have quantization noise which depends on the input voltage, especially at low Over Sampling Ratios (OSR), such as in fast mode. In some of the ADC modes, the quantization noise increases as the input voltage approaches the upper and lower limits of the ADC range. For example, the total measurement noise versus input voltage in normal and filtered modes is shown in Figure 5.

OPERATION

Table 3. ADC Filter Bandwidth, Accuracy and Speed

MODE	-3dB FILTER BW	-40dB FILTER BW	TME SPEC AT 3.3V, 25°C	TME SPEC AT 3.3V, -40°C, 125°C
27kHz (Fast Mode)	27kHz	84kHz	±5.5mV	±5.5mV
14kHz	13.5kHz	42kHz	±5.5mV	±5.5mV
7kHz (Normal Mode)	6.8kHz	21kHz	±1.8mV	±2.4mV
3kHz	3.4kHz	10.5kHz	±1.8mV	±2.4mV
2kHz	1.7kHz	5.3kHz	±1.8mV	±2.4mV
1kHz	845Hz	2.6kHz	±1.8mV	±2.4mV
422Hz	422Hz	1.3kHz	±1.8mV	±2.4mV
26Hz (Filtered Mode)	26Hz	82Hz	±1.8mV	±2.4mV

Note: TME is the total measurement error.

Table 4. ADC Range and Resolution

MODE	FULL RANGE ¹	SPECIFIED RANGE	PRECISION RANGE ²	LSB	FORMAT	MAX NOISE	NOISE FREE RESOLUTION ³
27kHz (fast)	-0.8192V to 5.7344V	0V to 5V	0.5V to 4.5V	100μV	Unsigned 16 Bits	±4mV _{p-p}	10 Bits
14kHz						±1mV _{p-p}	12 Bits
7kHz (normal)						±250μV _{p-p}	14 Bits
3kHz						±150μV _{p-p}	14 Bits
2kHz						±100μV _{p-p}	15 Bits
1kHz						±100μV _{p-p}	15 Bits
422Hz						±100μV _{p-p}	15 Bits
26Hz (filtered)						±50μV _{p-p}	16 Bits

1. Negative readings are rounded to 0V.

2. PRECISION RANGE is the range over which the noise is less than MAX NOISE.

3. NOISE FREE RESOLUTION is a measure of the noise level within the PRECISION RANGE.

The specified range of the ADC is 0V to 5V. In Table 4, the precision range of the ADC is arbitrarily defined as 0.5V to 4.5V. This is the range where the quantization noise is relatively constant even in the lower OSR modes (see Figure 5). Table 4 summarizes the total noise in this range

for all eight ADC operating modes. Also shown is the noise free resolution. For example, 14-bit noise free resolution in normal mode implies that the top 14 bits will be noise free with a DC input, but that the 15th and 16th least significant bits (LSB) will flicker.

OPERATION

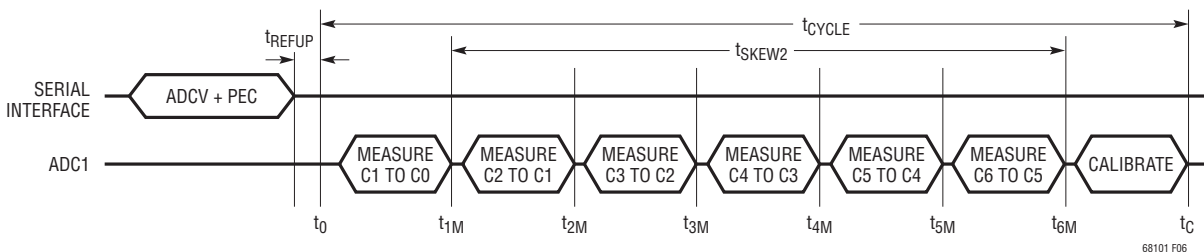

Figure 6. Timing for ADCV Command Measuring All 6 Cells, SCONV = 0

Table 5. Conversion and Synchronization Times for ADCV Command Measuring All Six Cells, SCONV = 0

MODE	CONVERSION TIMES (in μs)							SYNCHRONIZATION TIME (IN μs)
	t_0	t_{1M}	t_{2M}	t_{5M}	t_{6M}	$t_{C,MCAL=0}$	$t_{C,MCAL=1}$	t_{SKEW2}
27kHz	0	57	104	244	291	524	1,106	233
14kHz	0	87	162	390	465	699	1,281	379
7kHz	0	145	279	681	815	1,165	2,328	670
3kHz	0	261	511	1,262	1,513	1,863	3,026	1,252
2kHz	0	494	977	2,426	2,909	3,259	4,423	2,415
1kHz	0	959	1,908	4,753	5,702	6,052	7,215	4,742
422Hz	0	1,890	3,770	9,408	11,287	11,637	12,801	9,397
26Hz	0	29,818	59,624	149,044	178,851	182,692	201,310	149,033

Table 5 shows the conversion times for the ADCV command measuring all six cells. The total conversion time is given by t_C which indicates the end of the calibration step.

Figure 7 illustrates the timing of the ADCV command that measures only one cell.

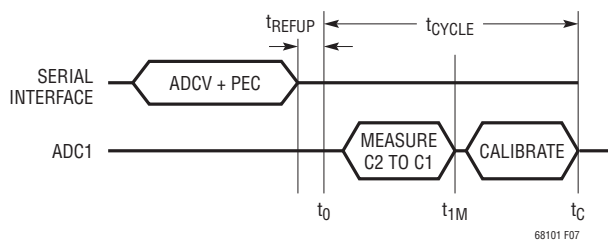

Figure 7. Timing for ADCV command measuring 1 cell, SCONV = 0

Table 6 shows the conversion time for ADCV command measuring only 1 cell. t_C indicates the total conversion time for this command.

Table 6. Conversion Times for ADCV Command Measuring Only One Cell, SCONV = 0

MODE	CONVERSION TIMES (in μs)		
	t_0	t_{1M}	t_C
27kHz	0	57	200
14kHz	0	87	229
7kHz	0	145	404
3kHz	0	261	520
2kHz	0	494	753
1kHz	0	959	1,218
422Hz	0	1,890	2,149
26Hz	0	29,817	33,567

OPERATION

Under/Over Voltage Monitoring

Whenever the C inputs are measured, the results are compared to under voltage and over voltage thresholds stored in memory. If the reading of a cell is above the over voltage limit, a bit in memory is set as a flag. Similarly, measurement results below the under voltage limit cause a flag to be set. The over voltage and under voltage thresholds are stored in the Configuration Register Group. The flags are stored in Status Register Group B.

Auxiliary (GPIO) Measurements (ADAX Command)

The ADAX command initiates the measurement of the GPIO inputs. This command has options to select which GPIO input to measure (GPIO1–4) and which ADC mode to use. The ADAX command also measures the S0 pin and the 2nd reference relative to the V^- pin voltage. There are options in the ADAX command to measure subsets of S0,

the GPIOs and the 2nd reference separately or to measure S0, all four GPIOs and the 2nd reference in a single command. See the section on Commands for the ADAX command format. All auxiliary measurements are relative to the V^- pin voltage. This command can be used to read external temperature by connecting the temperature sensors to the GPIOs. These sensors can be powered from the 2nd reference which is also measured by the ADAX command, resulting in precise ratiometric measurements.

Figure 8 illustrates the timing of the ADAX command measuring S0, all GPIOs and the 2nd reference. The 2nd reference is measured after GPIO4.

Table 7 shows the conversion time for the ADAX command measuring S0, all the GPIOs and the 2nd reference. t_C indicates the total conversion time.

The timing for ADAX measuring a single auxiliary is the same as ADCV measuring a single cell.

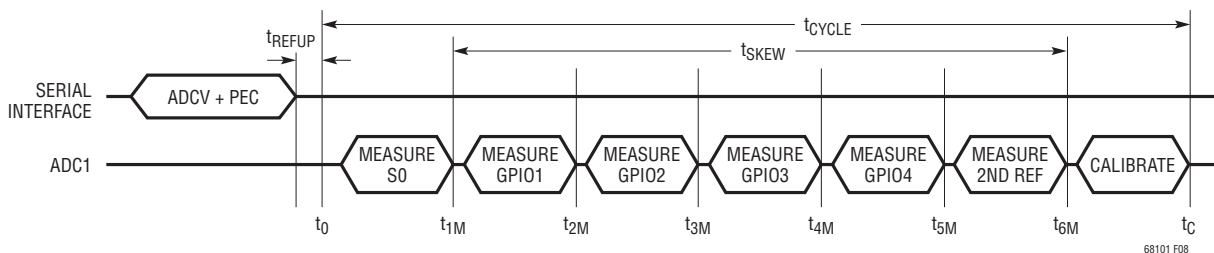

Figure 8. Timing for ADAX Command Measuring All GPIOs and 2nd Reference

Table 7. Conversion and Synchronization Times for ADAX Command Measuring S0, All GPIOs and 2nd Reference

MODE	CONVERSION TIMES (in μs)								
	t_0	t_{1M}	t_{2M}	t_{3M}	t_{4M}	t_{5M}	t_{6M}	$t_{C,MCAL=0}$	$t_{C,MCAL=1}$
27kHz	0	57	104	151	197	244	291	521	1,103
14kHz	0	87	162	238	314	390	465	695	1,277
7kHz	0	145	279	413	547	681	815	1,161	2,324
3kHz	0	261	511	762	1,012	1,262	1,513	1,859	3,023
2kHz	0	494	977	1,460	1,943	2,426	2,909	3,255	4,419
1kHz	0	959	1,908	2,856	3,805	4,753	5,702	6,048	7,212
422Hz	0	1,890	3,770	5,649	7,529	9,408	11,287	11,634	12,797
26Hz	0	29,818	59,624	89,431	119,238	149,044	178,851	182,688	201,306

OPERATION

Auxiliary (GPIO) Measurements with Digital Redundancy (ADAXD Command)

The ADAXD command operates similarly to the ADAX command except that an additional diagnostic is performed using digital redundancy. See A/D Conversion with Digital Redundancy.

The execution time of ADAX and ADAXD is the same.

Measuring Cell Voltages and GPIOs (ADCVAX Command)

The ADCVAX command combines six cell measurements with measurements of S0 and GPIO1. This command

simplifies the synchronization of battery cell voltage and current measurements when a current sensor is connected to the GPIO1 input. Figure 9 illustrates the timing of ADCVAX command with SCONV set to 0. See the section on Commands for the ADCVAX command format. The time values in Figure 9 assume the ADC is operating in the 27kHz (fast) mode. The synchronization of the current and voltage measurements, t_{SKEW1} , in fast mode is within 196 μs .

Table 8 shows the conversion and synchronization time for the ADCVAX command in different modes with SCONV = 0. The total conversion time for the command is given by t_{C} .

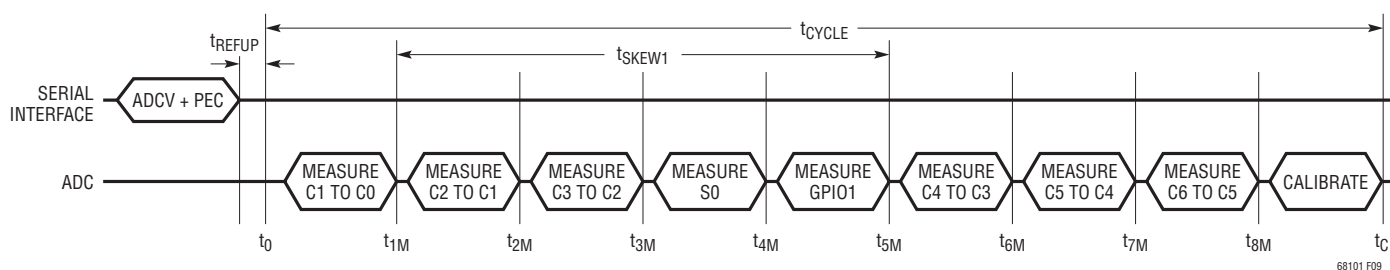

Figure 9. Timing of ADCVAX command, SCONV = 0

Table 8. Conversion and Synchronization Times for ADCVAX Command, SCONV = 0

MODE	CONVERSION TIMES (in μs)											SYNCHRONIZATION TIME (IN μs)
	t_0	t_{1M}	t_{2M}	t_{3M}	t_{4M}	t_{5M}	t_{6M}	t_{7M}	t_{8M}	$t_{\text{C,MCAL} = 0}$	$t_{\text{C,MCAL} = 1}$	t_{SKEW1}
27kHz	0	57	104	151	205	251	305	352	399	682	1,497	194
14kHz	0	87	162	238	321	397	480	556	631	915	1,730	310
7kHz	0	145	279	413	554	688	829	963	1,097	1,497	3,126	543
3kHz	0	261	511	762	1,019	1,270	1,527	1,777	2,028	2,427	4,057	1,008
2kHz	0	494	977	1,460	1,950	2,433	2,923	3,407	3,890	4,289	5,918	1,939
1kHz	0	959	1,908	2,856	3,812	4,760	5,716	6,665	7,613	8,013	9,642	3,801
422Hz	0	1,890	3,770	5,649	7,536	9,415	11,302	13,181	15,060	15,460	17,089	7,525
26Hz	0	29,817	59,624	89,431	119,245	149,051	178,865	208,672	238,479	242,369	268,435	119,234

OPERATION

DATA ACQUISITION SYSTEM DIAGNOSTICS

The battery monitoring data acquisition system is comprised of a multiplexer, an ADC, 1st reference, digital filters, and memory. To ensure long term reliable performance there are several diagnostic commands which can be used to verify the proper operation of these circuits.

Measuring Internal Device Parameters (ADSTAT Command)

The ADSTAT command is a diagnostic command that measures the following internal device parameters: Sum of All Cells (SC), Internal Die Temperature (ITMP), Analog Power Supply (VA) and Digital Power Supply (VD). These parameters are described in the section below. All the 8 ADC modes described earlier are available for these conversions. See the section on Commands for the ADSTAT command format.

Figure 10 illustrates the timing of the ADSTAT command measuring all the 4 internal device parameters.

Table 9 shows the conversion time of the ADSTAT command measuring all the 4 internal parameters. t_C indicates

the total conversion time for the ADSTAT command. When ADSTAT is performed measuring all 4 internal parameters, the LTC6810 will always perform four calibration cycles, regardless of MCAL.

The timing for ADSTAT measuring a single status parameter is the same as ADCV measuring a single cell.

Sum of All Cells Measurement: The Sum of All Cells measurement is the voltage between V^+ and V^- with a 10:1 attenuation. The V^+ to V^- voltage is the same as the total battery voltage when the IC is powered by the battery cells. The 16-bit ADC value of Sum of All Cells measurement (SC) is stored in Status Register Group A. From the SC value, the sum of all cell voltage measurements is given by,

$$\text{Sum of All Cells} = \text{SC} \cdot 10 \cdot 100\mu\text{V}$$

Internal Die Temperature: The ADSTAT command can measure the internal die temperature. The 16 bit ADC value of the die temperature measurement (ITMP) is stored in Status Register Group A. From ITMP, the actual die temperature is calculated using the expression,

$$\text{Internal Die Temperature (}^\circ\text{C)} = \text{ITMP} \cdot \frac{100\mu\text{V}}{7.5\text{mV}}^\circ\text{C} - 273^\circ\text{C}$$

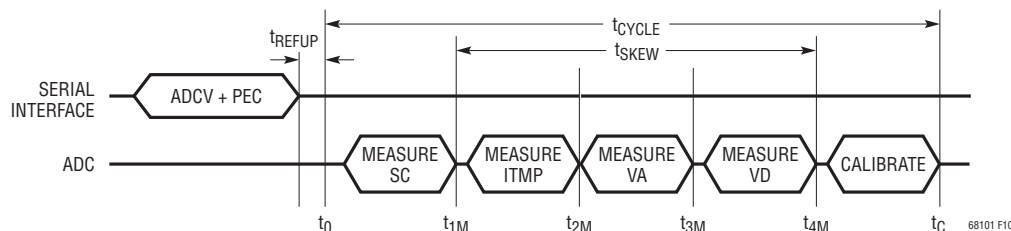

Figure 10. Timing for ADSTAT command measuring SC, ITMP, VA, VD

Table 9. Conversion and Synchronization Times for ADSTAT Command Measuring SC, ITMP, VA, VD

MODE	CONVERSION TIMES (in μs)							SYNCHRONIZATION TIME (in μs)
	t_0	t_{1M}	t_{2M}	t_{3M}	t_{4M}	$t_C, \text{MCAL} = 1 \text{ OR } 0$		t_{SKEW}
27kHz	0	57	104	151	197	741	0	140
14kHz	0	87	162	238	314	858	0	227
7kHz	0	145	279	413	547	1,556	0	402
3kHz	0	261	511	762	1,012	2,021	0	751
2kHz	0	494	977	1,460	1,943	2,952	0	1,449
1kHz	0	959	1,908	2,856	3,805	4,814	0	2,845
422Hz	0	1,890	3,770	5,649	7,528	8,538	0	5,638
26Hz	0	29,817	59,624	89,431	119,237	134,210	0	89,420

Rev. B

OPERATION

Power Supply Measurements: The ADSTAT command is also used to measure the Analog Power Supply (V_{REG}) and Digital Power Supply (V_{REGD}).

The 16 bit ADC value of the analog power supply measurement (VA) is stored in Status Register Group A. The 16 bit ADC value of the digital power supply measurement (VD) is stored in Status Register Group B. From VA and VD, the power supply measurements are given by:

$$\text{Analog Power Supply Measurement (} V_{REG} \text{)} = VA \cdot 100\mu\text{V}$$

$$\text{Digital Power Supply Measurement (} V_{REGD} \text{)} = VD \cdot 100\mu\text{V}$$

The value of V_{REG} is determined by external components. V_{REG} should be between 4.5V and 5.5V to maintain accuracy. The value of V_{REGD} is determined by internal components. The normal range of V_{REGD} is 2.7V to 3.6V.

Measuring Internal Device Parameters with Digital Redundancy (ADSTATD Command)

The ADSTATD command operates similarly to the ADSTAT command except that an additional diagnostic is performed

using digital redundancy. See the A/D Conversion with Digital Redundancy section.

The execution time of ADSTAT and ADSTATD is the same.

Measuring Cell Voltages and V^+ to V^- (ADCVSC Command)

The ADCVSC command combines six cell measurements and the measurement of Sum of All Cells. This command simplifies the synchronization of the individual battery cell voltage and the total Sum of All Cells measurement. Figure 11 illustrates the timing of ADCVSC command. See the section on Commands for the ADCVSC command format. The synchronization of the cell voltage and Sum of All Cells measurements, t_{SKEW} , in fast mode is within 147 μs .

Table 10 shows the conversion and synchronization time for the ADCVSC command in different modes (with $SCONV = 0$). The total conversion time for the command is given by t_C . When ADCVSC is performed, the LTC6810 will always perform seven calibration cycles, regardless of MCAL.

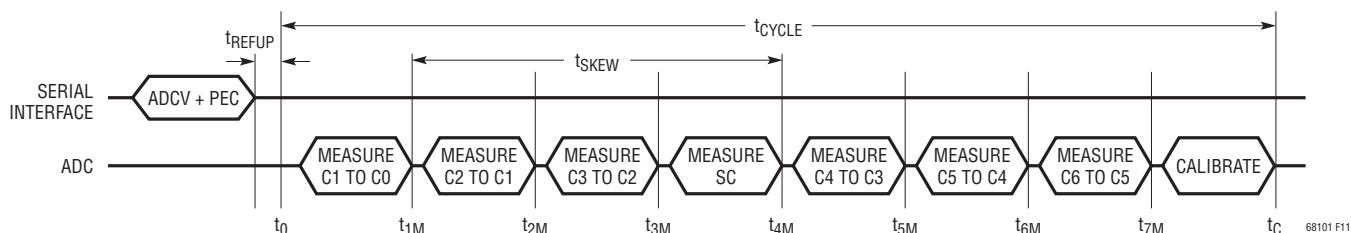

Figure 11. Timing for ADCVSC Command, $SCONV = 0$

Table 10. Conversion and Synchronization Times for ADCVSC Command, $SCONV = 0$

MODE	CONVERSION TIMES (in μs)									SYNCHRONIZATION TIME (in μs)
	t_0	t_{1M}	t_{2M}	t_{3M}	t_{4M}	t_{5M}	t_{6M}	t_{7M}	$t_{C,MCAL = 1 \text{ OR } 0}$	t_{SKEW}
27kHz	0	57	104	151	205	259	305	352	1,316	147
14kHz	0	87	162	238	321	404	480	556	1,520	235
7kHz	0	145	279	413	554	695	829	963	2,742	409
3kHz	0	261	511	762	1,019	1,277	1,527	1,777	3,556	758
2kHz	0	494	977	1,460	1,950	2,440	2,923	3,407	5,185	1,456
1kHz	0	959	1,908	2,856	3,812	4,768	5,716	6,665	8,443	2,853
422Hz	0	1,890	3,770	5,649	7,536	9,422	11,302	13,181	14,960	5,645
26Hz	0	29,817	59,624	89,431	119,245	149,059	178,865	208,672	234,887	89,427

OPERATION

A/D Conversion with Digital Redundancy

The internal ADC contains its own digital filter. The LTC6810 also contains a second digital filter that is used for redundancy and error checking.

All of the ADC and self test commands except ADAX and ADSTAT can operate with digital redundancy. This includes ADCV, ADOW, CVST, ADAXD, AXOW, AXST, ADSTATD, STATST, ADCVAX and ADCVSC. DIS_RED and SCONV must be set to 0 to enable digital redundancy during cell measurements (see Redundant Cell Measurement Using the S pins). When performing an ADC conversion with redundancy, the analog modulator sends its bit stream to both the primary digital filter and the redundant digital filter. At the end of the conversion the results from the two filters are compared. If any result bit mismatch is detected then a digital redundancy fault code is stored in place of the ADC result. The digital redundancy fault code is a value of 0xFF0X. This is detectable because it falls outside the normal result range of 0x0000 to 0xDFFF. The last 4 bits are used to indicate which nibble(s) of the result values did not match.

Indication of Digital Redundancy Fault Codes

DIGITAL REDUNDANCY FAULT CODE 4 LSBs	Indication
0b0XXX	No fault detected in bits 15–12.
0b1XXX	Fault detected in bits 15–12.
0bX0XX	No fault detected in bits 11–8.
0bX1XX	Fault detected in bits 11–8.
0bXX0X	No fault detected in bits 7–4.
0bXX1X	Fault detected in bits 7–4.
0bXXX0	No fault detected in bits 3–0.
0bXXX1	Fault detected in bits 3–0.
0b0000	The digital redundancy feature will not write this value of all zeros in the last 4 bits.

When the FDRF bit in the Configuration Register Group is written to 1 it will force the digital redundancy comparison to fail during subsequent A/D conversions. When the

DIS_RED bit in the Configuration Register Group is written to 1 it will disable the digital redundancy comparison and subsequent ADC commands will store the normal ADC result.

Redundant Cell Measurement Using the S pins

The LTC6810 has the ability to perform redundant measurements of the cells by measuring across the S pins. Redundant measurements using an independent pair of pins can be used to detect if leakage is present at the pins of the IC, in the external filter components or in the internal MUX. The Block Diagram (LTC6810-1) shows that both the C pins and the S pins can be connected to the ADC. If a cell is measured twice using two different measurement paths and the measurements agree, then the two paths can be considered to be functioning correctly.

The host can enable this feature by writing the SCONV bit in the Configuration Register Group to 1. Then any subsequent ADC command that measures a cell voltage will measure first using the C pins and then measure again using the S pins. The results of the C pin measurements are stored in the C voltage register groups. The results from the S pin measurements are stored in S voltage register groups (Redundant S Voltage Register Group A, Redundant S Voltage Register Group B). It is up to the host controller to compare the 2 measurements. The measurements may differ by several LSBs due to the quantization noise of the ADC and different external filtering on the C pins and S pins.

S pin measurements utilize the redundant digital filter to provide additional redundancy and error checking. So the digital redundancy feature is not available when performing cell measurements with S pins.

Figure 12 shows the ADCV sequence measuring 6 cells with redundant measurements enabled.

Table 11 shows the conversion times for the ADCV command measuring all six cells with redundant measurements enabled. The total conversion time is given by t_C which indicates the end of the calibration step.

OPERATION

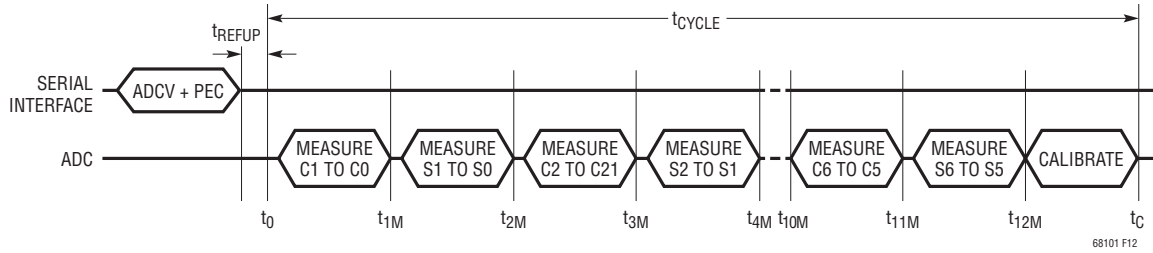

Figure 12. Timing for ADCV Command Measuring All 6 Cells, SCONV = 1

Table 11. Conversion Times for ADCV Command Measuring All Six Cells, SCONV = 1

MODE	CONVERSION TIMES (in μs)														
	t_0	t_{1M}	t_{2M}	t_{3M}	t_{4M}	t_{5M}	t_{6M}	t_{7M}	t_{8M}	t_{9M}	t_{10M}	t_{11M}	t_{12M}	$t_{C,MCAL=0}$	$t_{C,MCAL=1}$
27kHz	0	57	104	151	197	244	291	337	384	431	477	524	571	913	2,194
14kHz	0	87	163	238	314	390	466	541	617	693	769	844	920	1,263	2,543
7kHz	0	145	279	413	547	680	814	948	1,082	1,216	1,350	1,484	1,618	2,077	4,637
3kHz	0	261	511	762	1,012	1,262	1,513	1,763	2,013	2,263	2,514	2,764	3,014	3,473	6,033
2kHz	0	494	977	1,460	1,943	2,426	2,909	3,392	3,875	4,358	4,841	5,324	5,807	6,266	8,827
1kHz	0	959	1,908	2,856	3,805	4,753	5,702	6,650	7,599	8,547	9,496	10,444	11,393	11,852	14,412
422Hz	0	1,890	3,770	5,649	7,528	9,408	11,287	13,167	15,046	16,925	18,805	20,684	22,563	23,023	25,583
26Hz	0	29,818	59,624	89,431	119,238	149,044	178,851	208,658	238,464	268,271	298,078	327,884	357,691	361,641	402,601

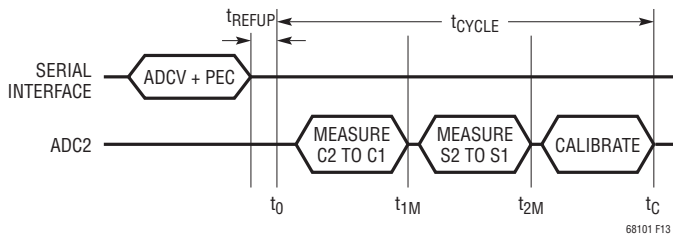

Figure 13. Timing for ADCV Command Measuring One Cell, SCONV = 1

Table 12. Conversion Times for ADCV Command Measuring Only One Cell, SCONV = 1

MODE	CONVERSION TIMES (in μs)				
	t_0	t_{1M}	t_{2M}	$t_{C,MCAL=0}$	$t_{C,MCAL=1}$
27kHz	0	57	104	265	381
14kHz	0	87	162	323	440
7kHz	0	145	279	556	789
3kHz	0	261	512	789	1,021
2kHz	0	494	977	1,254	1,487
1kHz	0	959	1,908	2,185	2,418
422Hz	0	1,890	3,770	4,047	4,280
26Hz	0	29,817	59,624	63,392	67,116

Figure 13 illustrates the timing of the ADCV command that measures one cell with redundant measurement.

Table 12 shows the conversion time for ADCV command measuring only 1 cell. t_C indicates the total conversion time for this command.

Figure 14 illustrates the timing of the ADCVAX command with SCONV set to 1.

Table 13 shows the conversion and synchronization time for the ADCVAX command in different modes with SCONV set to 1. The total conversion time for the command is given by t_C .

Figure 15 illustrates the timing of the ADCVSC command with SCONV set to 1.

Table 14 shows the conversion and synchronization time for the ADCVSC command in different modes with SCONV set to 1. The total conversion time for the command is given by t_C .

OPERATION

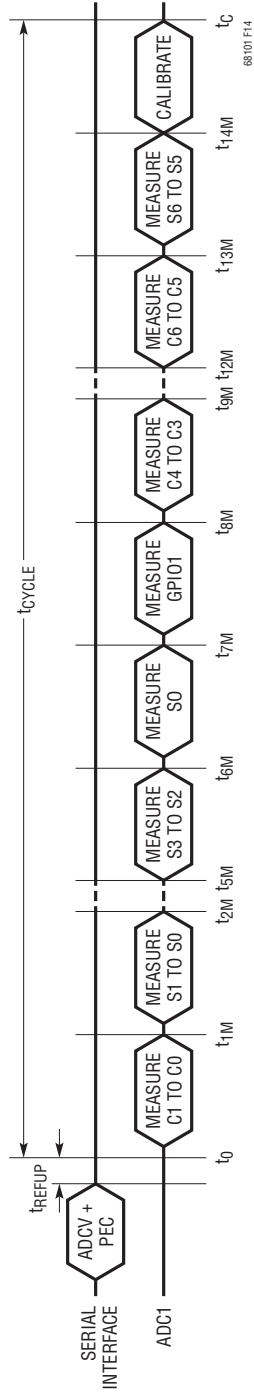

Figure 14. Timing of ADCVAX command, SCONV = 1

Table 13. Conversion Times for ADCVAX Command, SCONV = 1

MODE	CONVERSION TIMES (in μs)																
	t ₀	t _{1M}	t _{2M}	t _{3M}	t _{4M}	t _{5M}	t _{6M}	t _{7M}	t _{8M}	t _{9M}	t _{10M}	t _{11M}	t _{12M}	t _{13M}	t _{14M}	t _{c, MCAL = 0}	t _{c, MCAL = 1}
27kHz	0	58	104	151	198	244	291	345	392	446	500	546	593	640	686	1,086	2,599
14kHz	0	87	162	238	314	390	465	548	624	707	790	866	942	1,017	1,093	1,493	3,006
7kHz	0	145	279	413	547	681	815	956	1,090	1,231	1,372	1,506	1,640	1,774	1,908	2,424	5,449
3kHz	0	261	511	762	1,012	1,262	1,513	1,770	2,020	2,278	2,536	2,786	3,036	3,287	3,537	4,053	7,078
2kHz	0	494	977	1,460	1,943	2,426	2,909	3,399	3,882	4,373	4,863	5,346	5,829	6,312	6,795	7,311	10,337
1kHz	0	960	1,908	2,857	3,805	4,753	5,702	6,658	7,606	8,562	9,518	10,466	11,415	12,363	13,312	13,828	16,853
422Hz	0	1,890	3,770	5,649	7,528	9,408	11,287	13,174	15,053	16,940	18,827	20,706	22,585	24,465	26,344	26,860	29,886
26Hz	0	29,817	59,624	89,431	119,237	149,044	178,851	208,665	238,471	268,285	298,099	327,906	357,713	387,519	417,326	421,333	469,740

OPERATION

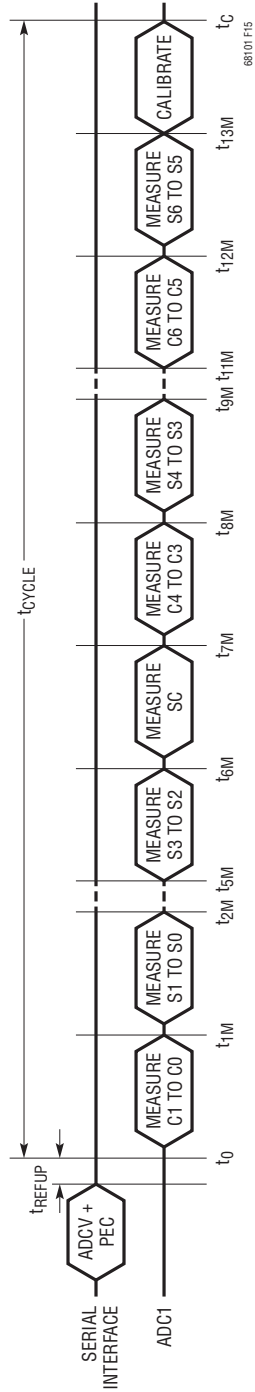

Figure 15. Timing of ADCVSC command, SCONV = 1

Table 14. Conversion Times for ADCVSC Command, SCONV = 1

MODE	CONVERSION TIMES (in μs)															
	t_0	t_{1M}	t_{2M}	t_{3M}	t_{4M}	t_{5M}	t_{6M}	t_{7M}	t_{8M}	t_{9M}	t_{10M}	t_{11M}	t_{12M}	t_{13M}	$t_c, \text{MCAL} = 0$	$t_c, \text{MCAL} = 1$
27kHz	0	58	104	151	198	244	291	345	399	453	500	546	593	640	2,418	2,418
14kHz	0	87	162	238	314	390	465	548	631	714	790	866	942	1,017	2,796	2,796
7kHz	0	145	279	413	547	681	815	956	1,097	1,238	1,372	1,506	1,640	1,774	5,065	5,065
3kHz	0	261	511	762	1,012	1,262	1,513	1,770	2,028	2,285	2,536	2,786	3,036	3,287	6,578	6,578
2kHz	0	494	977	1,460	1,943	2,426	2,909	3,399	3,890	4,380	4,863	5,346	5,829	6,312	9,603	9,603
1kHz	0	960	1,908	2,857	3,805	4,753	5,702	6,658	7,613	8,569	9,518	10,466	11,415	12,363	15,654	15,654
422Hz	0	1,890	3,770	5,649	7,528	9,408	11,287	13,174	15,060	16,947	18,827	20,706	22,585	24,465	27,756	27,756
26Hz	0	29,817	59,624	89,431	119,237	149,044	178,851	208,665	238,479	268,293	298,099	327,906	357,713	387,519	436,192	436,192

OPERATION

Accuracy Check

Measuring an independent voltage reference is the best means to verify the accuracy of a data acquisition system. The LTC6810 contains a 2nd reference for this purpose. The ADAX command will initiate the measurement of the 2nd reference. The results are placed in Auxiliary Register Group B. The range of the result depends on the accuracy of the 2nd reference, including thermal hysteresis and long term drift. Readings outside the range 2.99V to 3.01V (final data sheet limits plus 2mV for Hys and 3mV for LTD) indicate the system is out of its specified tolerance.

MUX Decoder Check

The diagnostic command DIAGN ensures the proper operation of each multiplexer channel. The command cycles through all channels and sets the MUXFAIL bit to 1 in Status Register Group B if any channel decoder fails. The MUXFAIL bit is set to 0 if the channel decoder passes the test. The MUXFAIL bit is also set to 1 on power-up (POR) or after a CLRSTAT command.

The DIAGN command takes about 300 μ s to complete if the Core is in REFUP state and about 3.8ms to complete if the Core is in STANDBY state. The polling methods described in the section Polling Methods can be used to determine the completion of the DIAGN command.

Digital Filter Check

The delta-sigma ADC is composed of a 1-bit pulse density modulator followed by a digital filter. A pulse density modulated bit stream has a higher percentage of 1s for higher analog input voltages. The digital filter converts this high frequency 1-bit stream into a single 16-bit word. This is why a delta-sigma ADC is often referred to as an over-sampling converter.

The self test commands verify the operation of the digital filters and memory. Figure 16 illustrates the operation of the ADC during self test. The output of the 1-bit pulse density modulator is replaced by a 1-bit test signal. The test signal passes through the digital filter and is converted to a 16-bit value. The 1-bit test signal undergoes the same digital conversion as the regular 1-bit pulse from the modulator, so the conversion time for any self test command is exactly the same as the corresponding regular ADC conversion command. The 16-bit ADC value is stored in the same register groups as the regular ADC conversion command. The total conversion time for the self test commands is the same as the regular ADC conversion commands. The test signals are designed to place alternating one-zero patterns in the registers.

Table 15 provides a list of the self test commands. If the digital filters and memory are working properly, then the registers will contain the values shown in Table 15. For more details see the Commands section.

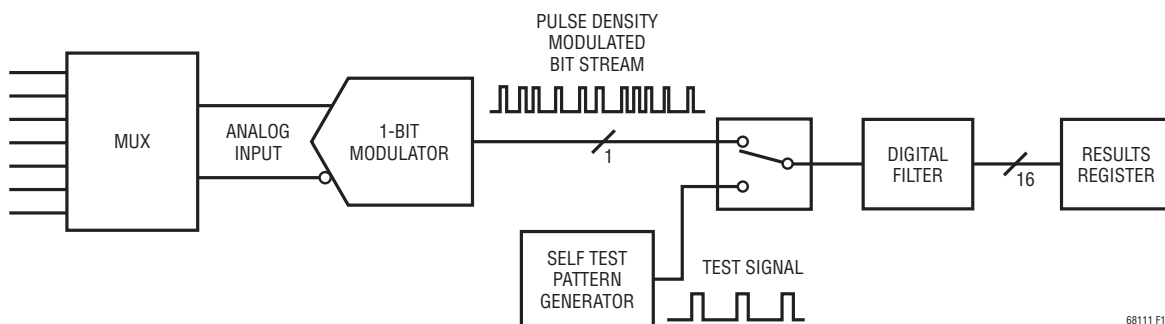

Figure 16. Operation of LTC6810 ADC Self Test

OPERATION

Table 15. Self Test Command Summary

COMMAND	SELF TEST OPTION	OUTPUT PATTERN IN DIFFERENT ADC MODES			RESULTS REGISTER GROUPS
		27kHz	14kHz	7kHz, 3kHz, 2kHz, 1kHz, 422Hz, 26Hz	
CVST	ST[1:0] = 01	0x9565	0x9553	0x9555	C1V to C18V (CVA, CVB, CVC, CVD)
	ST[1:0] = 10	0x6A9A	0x6AAC	0x6AAA	
AXST	ST[1:0] = 01	0x9565	0x9553	0x9555	S0, G1V to G4V, REF (AUXA, AUXB)
	ST[1:0] = 10	0x6A9A	0x6AAC	0x6AAA	
STATST	ST[1:0] = 01	0x9565	0x9553	0x9555	SC, ITMP, VA, VD (STATA, STATB)
	ST[1:0] = 10	0x6A9A	0x6AAC	0x6AAA	

ADC Clear Commands

LTC6810 has 3 clear ADC commands: CLRCELL, CLRAUX and CLRSTAT. These commands clear the registers that store all ADC conversion results.

The CLRCELL command clears Cell Voltage Register Group A, B and the Redundant S Voltage Register Group A, B. All bytes in these registers are set to 0xFF by CLRCELL command.

The CLRAUX command clears Auxiliary Register Group A and B. All bytes in these registers are set to 0xFF by CLRAUX command.

The CLRSTAT command clears Status Register Group A and B except the REVCODE and RSVD bits in Status Register Group B. A read back of REVCODE will return the revision code of the part. RSVD bits always read back 0s. All OV and UV flags, MUXFAIL bit, and THSD bit in Status Register Group B are set to 1 by CLRSTAT command. The THSD bit is set to 0 after RDSTATB command. The registers storing SC, ITMP, VA and VD are all set to 0xFF by CLRSTAT command.

Open Wire Check (ADOW Command)

The ADOW command is used to check for any open wires between the ADCs of the LTC6810 and the external cells. This command performs ADC conversions on the C pin inputs identically to the ADCV command, except two internal current sources sink or source current into the two C pins while they are being measured. The pull-up (PUP) bit of the ADOW command determines whether the current sources are sinking or sourcing 100µA.

The following simple algorithm can be used to check for an open wire on any of the 7 C pins:

1. Run the 6-cell command ADOW with PUP = 1 at least twice. Read the cell voltages for cells 1 through 6 once at the end and store them in array CELLPU(n).
2. Run the 6-cell command ADOW with PUP = 0 at least twice. Read the cell voltages for cells 1 through 6 once at the end and store them in array CELLPD(n).
3. Take the difference between the pull-up and pull-down measurements made in above steps for cells 2 to 6: $CELL\Delta(n) = CELLPU(n) - CELLPD(n)$.
4. For all values of n from 1 to 5: If $CELL\Delta(n+1) < -400mV$, then C(n) is open. If $CELLPU(1) = 0.0000$, then C(0) is open. If $CELLPD(6) = 0.0000$, then C(6) is open.

The above algorithm detects open wires using normal mode conversions with as much as 10nF of capacitance on the LTC6810 side of the open wire. However, if more external capacitance is on the open C pin, then the length of time that the open wire conversions are run in steps 1 and 2 must be increased to give the 100µA current sources time to create a large enough difference for the algorithm to detect an open connection. This can be accomplished by running more than two ADOW commands in steps 1 and 2, or by using filtered mode conversions instead of normal mode conversions. Use Table 16 to determine how many conversions are necessary.

OPERATION

Table 16.

EXTERNAL C PIN CAPACITANCE	NUMBER OF ADOW COMMANDS REQUIRED IN STEPS 1 AND 2	
	NORMAL MODE	FILTERED MODE
≤10nF	2	2
100nF	10	2
1μF	100	2
C	1 + ROUNDUP(C/10nF)	2

Thermal Shutdown

To protect the LTC6810 from over-heating, there is a thermal shutdown circuit included inside the IC. If the temperature detected on the die goes above approximately 150°C, the thermal shutdown circuit trips and resets the Configuration Register Group and PWM Register Group to their default state. This turns off all discharge switches. When a thermal shutdown event has occurred, the THSD bit in Status Register Group B will go high. The CLRSTAT command can also set the THSD bit high for diagnostic purposes. This bit is cleared when a read operation is performed on the Status Register Group B (RDSTATB command).

Revision Code and Reserved Bits

The Status Register Group B contains a 4-bit revision code. If software detection of device revision is necessary, then contact the factory for details. Otherwise the code can be ignored. In all cases, however, the values of all bits must be used when calculating the Packet Error Code (PEC) on data reads.

WATCHDOG AND DISCHARGE TIMER

When there is no valid command for more than 2 seconds, the watchdog timer expires. This resets Configuration Register bytes CFGR0, CFGR1-3 (if DTMEN=0), CFGR4, CFGR5, and the PWM configuration bits in the PWM Register Group are reset by the watchdog timer when the Discharge Timer is disabled. The WDT pin is pulled high by the external pull-up when the watchdog time elapses. The watchdog timer is always enabled and it resets after every valid command with matching command PEC.

The discharge timer is used to enable cell discharge using pulse width modulation, for programmable time duration after the watchdog time elapses. To enable the Discharge Timer, tie the DTEN pin high to V_{REGA} (Figure 17) and write the DCTO value in the Configuration Register Group

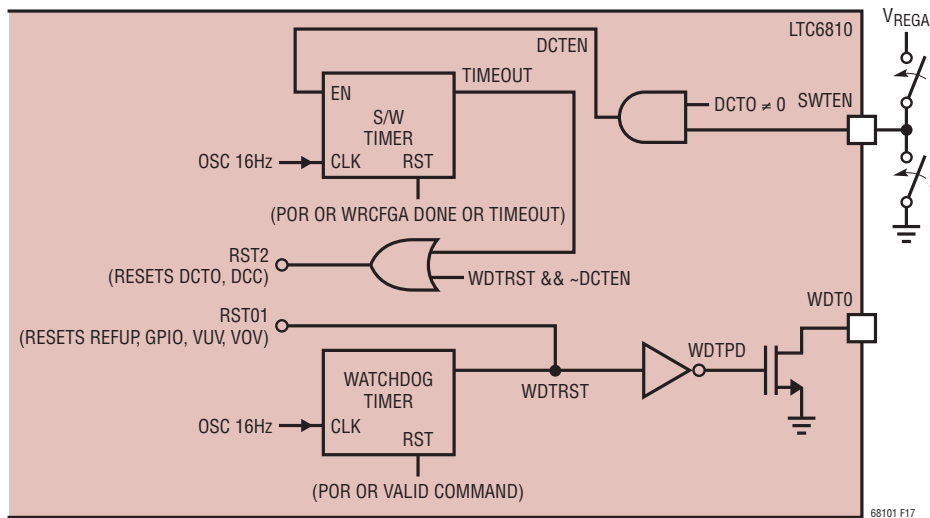

Figure 17. Watchdog and Discharge Timer

OPERATION

Table 17. DCTO Settings

DCTO	0	1	2	3	4	5	6	7	8	9	A	B	C	D	E	F
Time (min)	Disabled	0.5	1	2	3	4	5	10	15	20	30	40	60	75	90	120

to a non-zero value. Once the watchdog time elapses, the discharge switches are now allowed to discharge at a duty cycle specified by the PWM configuration bits in the PWM Register Group for a time duration that is determined by the DCTO value. Table 17 shows the various time settings and the corresponding DCTO value. Table 18 summarizes the status of the Configuration Register Group after a watchdog timer or discharge timer event.

The status of the discharge timer can be determined by reading the configuration register using the RDCFG command. The DCTO value indicates the time left before the Discharge Timer expires as shown in Table 19.

Unlike the watchdog timer, the discharge timer does not reset when there is a valid command. The discharge timer is only reset after a valid WRCFG (Write Configuration Register Group) command. There is a possibility that the Discharge Timer will expire in the middle of some commands.

If Discharge Timer expires in the middle of WRCFG command, the Configuration Register Group and PWM Register Group reset as per Table 18. However, at the end of the valid WRCFG command, the new data is copied to the configuration register. The new data is not lost when the Discharge Timer fired.

If Discharge Timer fires in the middle of RDCFG command, the Configuration Register Group resets as per Table 18. As a result, the read back data from bytes CRFG4 and CRFG5 could be corrupted. If Discharge Timer fires in the middle of WRPWM or RDPWM command, the PWM Register Group resets as per Table 18. As a result, the data could be corrupted.

Table 18

	WATCHDOG TIMER	DISCHARGE TIMER
DTEN = 0, DCTO = XXXX	Resets CFGR0-5 and PWM bits when it fires.	Disabled
DTEN = 1, DCTO = 0000	Resets CFGR0-5 and PWM bits when it fires.	Disabled
DTEN = 1, DCTO != 0000	Resets CFGR0, CFGR1-3 (if DTMEN=0) when it fires.	Resets CFGR1-3 (if DTMEN =1), and PWM bits when it fires.

Table 19.

DCTO (READ VALUE)	TIME LEFT (MIN)
0	Disabled (or) Discharge Timer Has Timed Out
1	0 < Timer ≤ 0.5
2	0.5 < Timer ≤ 1
3	1 < Timer ≤ 2
4	2 < Timer ≤ 3
5	3 < Timer ≤ 4
6	4 < Timer ≤ 5
7	5 < Timer ≤ 10
8	10 < Timer ≤ 15
9	15 < Timer ≤ 20
A	20 < Timer ≤ 30
B	30 < Timer ≤ 40
C	40 < Timer ≤ 60
D	60 < Timer ≤ 75
E	75 < Timer ≤ 90
F	90 < Timer ≤ 120

OPERATION

RESET BEHAVIORS

Power cycling, thermal shutdown, watchdog timeout and discharge timeout can cause various registers and circuitry to reset when they occur. The following summarizes the behaviors when these events occur:

RESET EVENT	DEVICE BEHAVIOR
Power Cycle (V^+ and V_{REG} both power cycled)	Transition to STANDBY state. All registers and state machines are reset to default values. Cell discharge is disabled.
Thermal Shutdown	Cell discharge is disabled. All of Configuration Register Group is reset. The COMM Register Group is reset.
Watchdog Timeout (while Discharge Timer is Running)	Transition to EXTENDED BALANCING state. CFGR0 of Configuration Register is reset. If DTMEN (in Configuration Register Group) = 0 then CFGR1, CFGR2 and CFGR3 of Configuration Register Group are reset. The COMM Register Group is reset.
Watchdog Timeout (no Discharge Timer Running)	Transition to SLEEP state. Cell discharge is disabled. All state machines are reset. All of Configuration Register Group is reset. The PWM Register Group is reset. The COMM Register Group is reset.
Discharge Timeout (while Watchdog Timeout has Elapsed)	Transition to SLEEP state. Same behavior as the previous case above.
Discharge Timeout (while Watchdog Timeout is not Elapsed)	Cell discharge is disabled. The PWM Register Group is reset. If DTMEN (in Configuration Register) = 1 then CFGAR1, CFGAR2 and CFGAR3 of Configuration Register Group are reset. CFGAR4 and CFGAR5 of Configuration Register Group are reset.

OPERATION

S PIN PULSE WIDTH MODULATION FOR CELL BALANCING

While the watchdog timer is not expired, the DCC bits in the Configuration Register Group control the S pins directly. After the watchdog timer expires, PWM operation begins and continues for the remainder of the selected software discharge time or until a wake-up event occurs (and the watchdog timer is reset).

Once PWM operation begins, the configurations in the PWM Register Group control the S pins to achieve the desired duty cycle as shown in Table 20. Each PWM signal operates on a 30 second period. For each cell, the duty-cycle can be programmed from 0% to 50% duty cycle in increments of $1/30 = 3.33\%$ (1 second). S pins for adjacent cells are never activated at the same time, hence the maximum 50% duty cycle. There is a non-overlap of at least 1ms between activation of any two adjacent S pins.

Table 20. PWM Configurations

DTEN SETTING	PWMC SETTING	ON TIME [SECONDS]	OFF TIME [SECONDS]	DUTY CYCLE [%]
1'b0	4'bXXXX	0	Continuously Off	0
1'b1	4'b1111	15	15	50
1'b1	4'b1110	14	16	46.7
1'b1	4'b1101	13	17	43.3
1'b1	4'b1100	12	18	40
1'b1	4'b1011	11	19	36.7
1'b1	4'b1010	10	20	33.3
1'b1	4'b1001	9	21	30
1'b1	4'b1000	8	22	26.7
1'b1	4'b0111	7	23	23.3
1'b1	4'b0110	6	24	20
1'b1	4'b0101	5	25	16.7
1'b1	4'b0100	4	26	13.3
1'b1	4'b0011	3	27	10
1'b1	4'b0010	2	28	6.7
1'b1	4'b0001	1	29	3.3
1'b1	4'b0000	0	Continuously Off	0

The PWM turn on/off times for the S pins are sequenced at different intervals so that no two pins switch on or off

at the same time. The switching interval between channels is 62.5ms, and 375ms are required for all 6 pins to switch ($6 \cdot 62.5\text{ms}$).

The default value of the PWMC settings in the PWM Register Group is all 0s. Upon entry to sleep mode, the PWMC settings will be reset to their default value.

DISCHARGE TIMER MONITOR

The LTC6810 has the ability to periodically monitor cell voltages while the discharge timer is active. The host should write the DTMEN bit in the Configuration Register Group to 1 to enable this feature.

When the discharge timer monitor is enabled and the watchdog timer has expired, the LTC6810 will perform a conversion of all cell voltages in 7kHz (Normal) Mode every 30 seconds. The overvoltage and undervoltage comparisons will be performed and flags will be set if cells have crossed a threshold. For any undervoltage cells the discharge timer monitor will automatically clear the associated PWMC bits in the PWM Register Group so that the cell will no longer be discharged. Clearing the Discharge Control bit will also disable PWM discharge. With this feature, the host can write the undervoltage threshold to the desired discharge level and use the discharge timer monitor to discharge all, or selected, cells down to that level.

During discharge timer monitoring, digital redundancy checking will be performed on the cell voltage measurements. If a digital redundancy failure occurs, all PWMC bits will be cleared and discharge will be terminated.

I²C/SPI MASTER ON LTC6810 USING GPIOs

The I/O ports GPIO2, GPIO3 and GPIO4 on LTC6810 can be used as an I²C or SPI master port to communicate to an I²C or SPI slave. In case of I²C master, GPIO3 and GPIO4 form the SDA and SCL ports of the I²C interface respectively. In case of SPI master, GPIO2, GPIO3 and GPIO4 become the CSB, SDIO and SCK ports of the SPI interface respectively. The SPI master on LTC6810 supports SPI mode 3 (CHPA = 1, CPOL = 1).

OPERATION

The GPIOs are open drain outputs, so an external pull up is required on these ports to operate as an I²C or SPI master. It is also important to write the GPIO bits to 1 in the CFG register group so these ports are not pulled low internally by the device.

COMM Register

LTC6810 has a 6 byte COMM register as shown in Table 21. This register stores all data and control bits required for I²C or SPI communication to a slave. The COMM register contains 3 bytes of data Dn[7:0] to be transmitted to or received from the slave device. ICOMn[3:0] specify control actions before transmitting/receiving the data byte. FCOMn[3:0] specify control actions after transmitting/receiving the data byte.

If the bit ICOMn[3] in the COMM register is set to 1 the part becomes an SPI master and if the bit is set to 0 the part becomes a I²C master.

Table 22 describes the valid write codes for ICOMn[3:0] and FCOMn[3:0] and their behavior when using the part as an I²C master.

Table 23 describes the valid codes for ICOMn[3:0] and FCOMn[3:0] and their behavior when using the part as an SPI master.

Note that only the codes listed in Table 22 and Table 23 are valid for ICOMn[3:0] and FCOMn[3:0]. Writing any other code that is not listed above to ICOMn[3:0] and FCOMn[3:0] may result in unexpected behavior on the I²C and SPI ports.

Table 21. COMM Register Memory Map

REGISTER	RD/WR	BIT 7	BIT 6	BIT 5	BIT 4	BIT 3	BIT 2	BIT 1	BIT 0
COMM0	RD/WR	ICOM0[3]	ICOM0[2]	ICOM0[1]	ICOM0[0]	D0[7]	D0[6]	D0[5]	D0[4]
COMM1	RD/WR	D0[3]	D0[2]	D0[1]	D0[0]	FCOM0[3]	FCOM0[2]	FCOM0[1]	FCOM0[0]
COMM2	RD/WR	ICOM1[3]	ICOM1[2]	ICOM1[1]	ICOM1[0]	D1[7]	D1[6]	D1[5]	D1[4]
COMM3	RD/WR	D1[3]	D1[2]	D1[1]	D1[0]	FCOM1[3]	FCOM1[2]	FCOM1[1]	FCOM1[0]
COMM4	RD/WR	ICOM2[3]	ICOM2[2]	ICOM2[1]	ICOM2[0]	D2[7]	D2[6]	D2[5]	D2[4]
COMM5	RD/WR	D2[3]	D2[2]	D2[1]	D2[0]	FCOM2[3]	FCOM2[2]	FCOM2[1]	FCOM2[0]

Table 22. Write Codes for ICOMn[3:0] and FCOMn[3:0] on I²C Master

CONTROL BITS	CODE	ACTION	DESCRIPTION
ICOMn[3:0]	0110	START	Generate a START signal on I ² C port followed by data transmission.
	0001	STOP	Generate a STOP signal on I ² C port.
	0000	BLANK	Proceed directly to data transmission on I ² C port.
	0111	No Transmit	Release SDA and SCL and ignore the rest of the data.
FCOMn[3:0]	0000	Master ACK	Master generates an ACK signal on ninth clock cycle.
	1000	Master NACK	Master generates a NACK signal on ninth clock cycle.
	1001	Master NACK + STOP	Master generates a NACK signal followed by STOP signal.

Table 23. Write Codes for ICOMn[3:0] and FCOMn[3:0] on SPI Master

CONTROL BITS	CODE	ACTION	DESCRIPTION
ICOMn[3:0]	1000	CSBM low	Generates a CSBM low signal on SPI port (GPIO3).
	1010	CSBM falling edge	Drives CSBM (GPIO3) high, then low.
	1001	CSBM high	Generates a CSBM high signal on SPI port (GPIO3).
	1111	No Transmit	Releases the SPI port and ignores the rest of the data.
FCOMn[3:0]	X000	CSBM low	Holds CSBM low at the end of byte transmission.
	1001	CSBM high	Transitions CSBM high at the end of byte transmission.

OPERATION

COMM Commands

Three commands help accomplish I²C or SPI communication to the slave device: WRCOMM, STCOMM, RDCOMM

WRCOMM Command: This command is used to write data to the COMM register. This command writes 6 bytes of data to the COMM register. The PEC needs to be written at the end of the data. If the PEC does not match, all data in the COMM register is cleared to 1s when CSB goes high. See the Bus Protocols section for more details on a write command format.

STCOMM Command: This command initiates I²C/SPI communication on the GPIO ports. The COMM register contains 3 bytes of data to be transmitted to the slave. During this command, the data bytes stored in the COMM register are transmitted to the slave I²C or SPI device and the data received from the I²C or SPI device is stored in the COMM register. This command uses GPIO3 (SDA) and GPIO4 (SCL) for I²C communication or GPIO2 (CSBM), GPIO3 (SDIOM) and GPIO4 (SCKM) for SPI communication.

The STCOMM command is to be followed by 24 clock cycles for each byte of data to be transmitted to the slave device while holding CSB low. For example, to transmit 3 bytes of data to the slave, send STCOMM command and its PEC followed by 72 clock cycles. Pull CSB high at the end of the 72 clock cycles of STCOMM command.

During I²C or SPI communication, the data received from the slave device is updated in the COMM register.

RDCOMM Command: The data received from the slave device can be read back from the COMM register using the RDCOMM command. The command reads back 6 bytes of data followed by the PEC. See the Bus Protocols section for more details on a read command format.

Table 24 describes the possible read back codes for ICOMn[3:0] and FCOMn[3:0] when using the part as an I²C master. Dn[3:0] contains the data byte transmitted by the I²C slave.

In case of the SPI master, the read back codes for ICOMn[3:0] and FCOMn[3:0] are always 0111 and 1111 respectively. Dn[3:0] contains the data byte transmitted by the SPI slave.

Table 24. Read Codes for ICOMn[3:0] and FCOMn[3:0] on I²C Master

CONTROL BITS	CODE	DESCRIPTION
ICOMn[3:0]	0110	Master generated a START signal.
	0001	Master generated a STOP signal.
	0000	Blank, SDA was held low between bytes.
	0111	Blank, SDA was held high between bytes.
FCOMn[3:0]	0000	Master generated an ACK signal.
	0111	Slave generated an ACK signal.
	1111	Slave generated a NACK signal.
	0001	Slave generated an ACK signal, master generated a STOP signal.
	1001	Slave generated a NACK signal, master generated a STOP signal.

Figure 18 illustrates the operation of LTC6810 as an I²C or SPI master using the GPIOs.

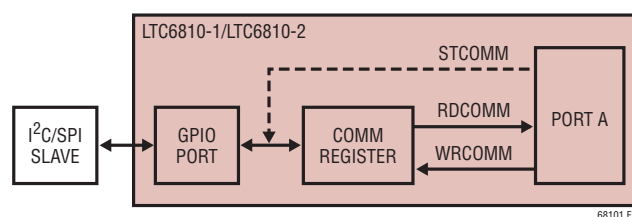

Figure 18. LTC6810 I²C/SPI Master using GPIOs

Any number of bytes can be transmitted to the slave in groups of 3 bytes using these commands. The GPIO ports will not get reset between different STCOMM commands. However, if the wait time between the commands is greater than 2s, the watchdog will time out and reset the ports to their default values.

To transmit several bytes of data using an I²C master, a START signal is only required at the beginning of the entire data stream. A STOP signal is only required at the end of the data stream. All intermediate data groups can use a BLANK code before the data byte and an ACK/NACK signal as appropriate after the data byte. SDA and SCL will not get reset between different STCOMM commands.

To transmit several bytes of data using SPI master, a CSBM low signal is sent at the beginning of the 1st data byte. CSBM can be held low or taken high for intermediate data groups using the appropriate code on FCOMn[3:0].

OPERATION

A CSB high signal is sent at the end of the last byte of data. CSBM, SDIOM and SCKM will not get reset between different STCOMM commands.

Figure 19 shows the 24 clock cycles following STCOMM command for an I²C master in different cases. Note that if ICOMn[3:0] specified a STOP condition, after the STOP

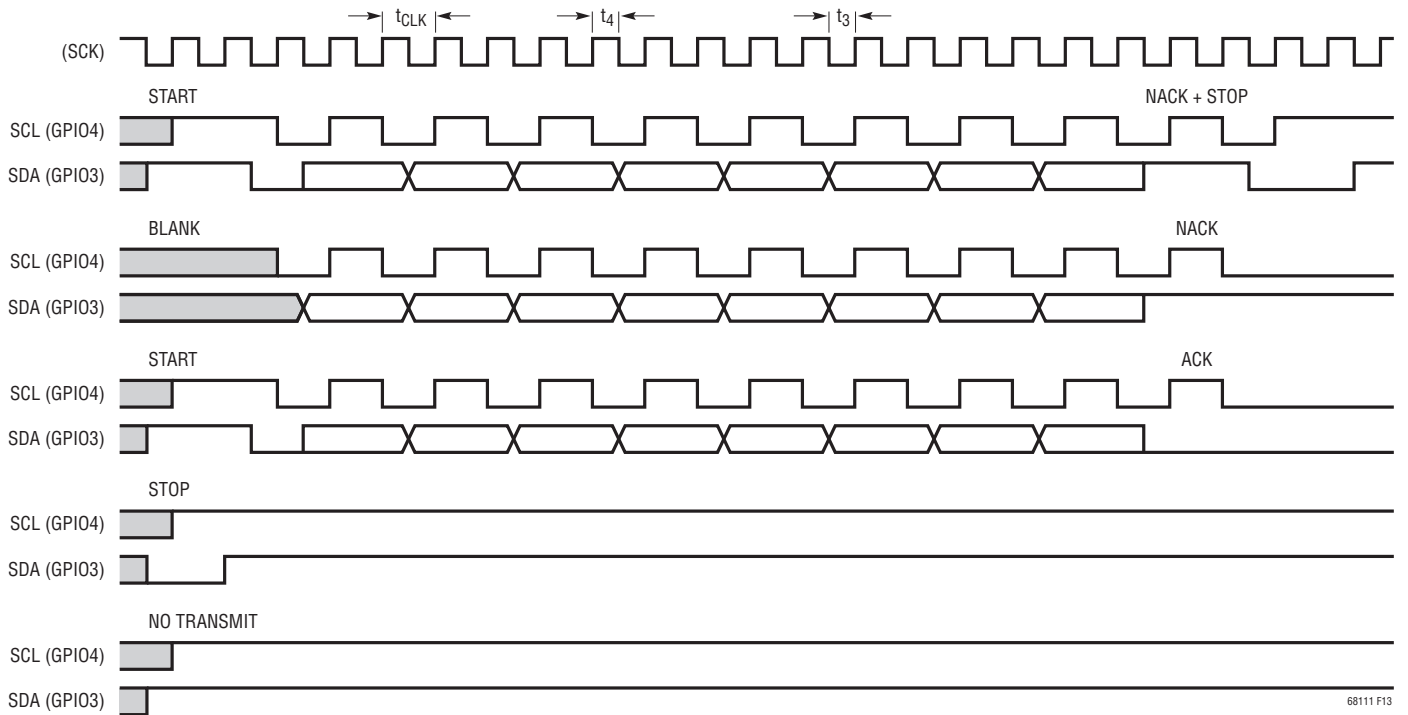

Figure 19. STCOMM Timing Diagram for an I²C Master

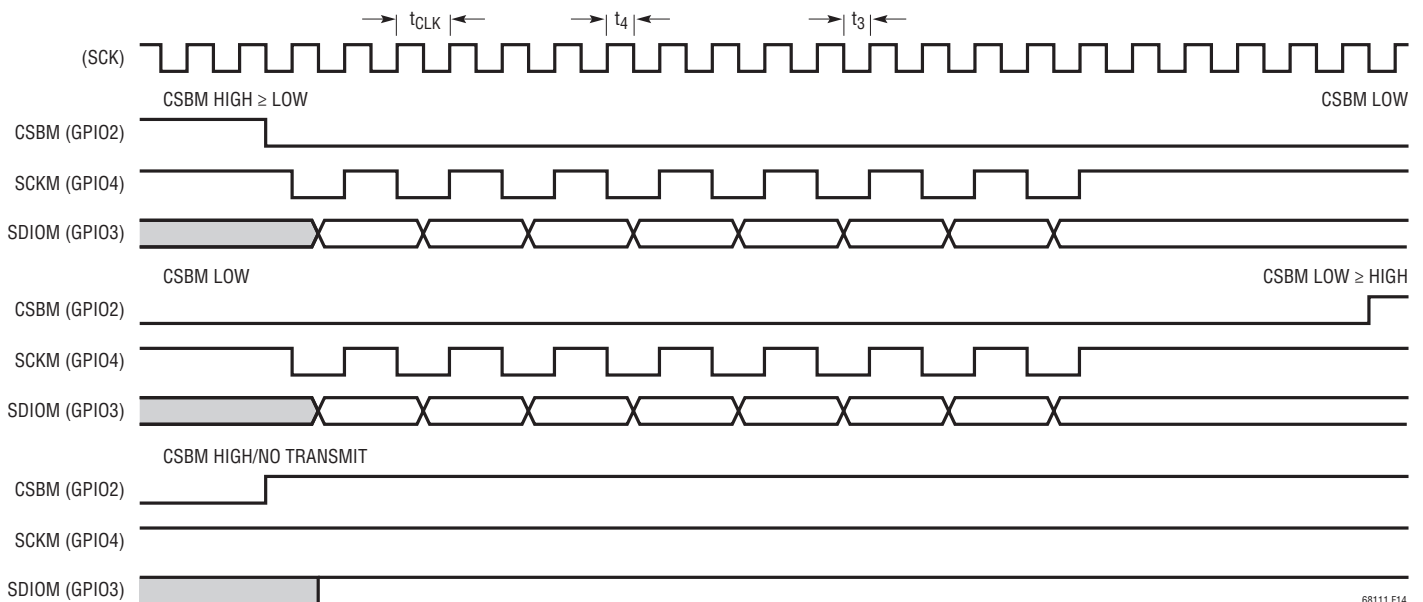

Figure 20. STCOMM Timing Diagram for a SPI Master

OPERATION

signal is sent, the SDA and SCL lines are held high and all data in the rest of the word is ignored. If ICOMn[3:0] is a NO TRANSMIT, both SDA and SCL lines are released, and rest of the data in the word is ignored. This is used when a particular device in the stack does not have to communicate to a slave.

Figure 20 shows the 24 clock cycles following STCOMM command for a SPI master. Similar to the I²C master, if ICOMn[3:0] specified a CSBM HIGH or a NO TRANSMIT condition, the CSBM, SCKM and SDIOM lines of the SPI master are released and the rest of the data in the word is ignored.

Timing Specifications of I²C and SPI master

The timing of the LTC6810 I²C or SPI master will be controlled by the timing of the communication at the LTC6810's primary SPI interface. Table 25 shows the I²C master timing relationship to the primary SPI clock. Table 26 shows the SPI master timing specifications.

Table 25. I²C MASTER TIMING

I ² C MASTER PARAMETER	TIMING RELATIONSHIP TO PRIMARY SPI INTERFACE	TIMING SPECIFICATIONS AT t _{CLK} = 1μs
SCL Clock Frequency	1/(2 • t _{CLK})	Max 500kHz
t _{HD;STA}	t ₃	Min 200ns
t _{LOW}	t _{CLK}	Min 1μs
t _{HIGH}	t _{CLK}	Min 1μs
t _{SU;STA}	t _{CLK} + t ₄ *	Min 1.03μs
t _{HD;DAT}	t ₄ *	Min 30ns
t _{SU;DAT}	t ₃	Min 200ns
t _{SU;STO}	t _{CLK} + t ₄ *	Min 1.03μs
t _{BUF}	3 • t _{CLK}	Min 3μs

*Note: When using isoSPI, t₄ is generated internally and is a minimum of 30ns. Also, t₃ = t_{CLK} - t₄. When using SPI, t₃ and t₄ are the low and high times of the SCK input, each with a specified minimum of 200ns.

Table 26. SPI Master Timing

SPI MASTER PARAMETER	TIMING RELATIONSHIP TO PRIMARY SPI INTERFACE	TIMING SPECIFICATIONS AT t _{CLK} = 1μs
SDIOM Valid to SCKM Rising Setup	t ₃	Min 200ns
SDIO Valid from SCKM Rising Hold	t _{CLK} + t ₄ *	Min 1.03μs
SCKM Low	t _{CLK}	Min 1μs
SCKM High	t _{CLK}	Min 1μs
SCKM Period (SCKM_Low + SCKM_High)	2 • t _{CLK}	Min 2μs
CSBM Pulse Width	3 • t _{CLK}	Min 3μs
SCKM Rising to CSBM Rising	5 • t _{CLK} + t ₄ *	Min 5.03μs
CSBM Falling to SCKM Falling	t ₃	Min 200ns
CSBM Falling to SCKM Rising	t _{CLK} + t ₃	Min 1.2μs
SCKM Falling to SDIOM Valid	Master requires < t _{CLK}	

*Note: When using isoSPI, t₄ is generated internally and is a minimum of 30ns. Also, t₃ = t_{CLK} - t₄. When using SPI, t₃ and t₄ are the low and high times of the SCK input, each with a specified minimum of 200ns.

S PIN MUTING

The S pins may be disabled by sending the MUTE command and re-enabled by sending the UNMUTE command. The MUTE and UNMUTE commands do not require any subsequent data and thus the commands will propagate quickly through a stack of LTC6810-1 devices. Likewise, they can be sent as broadcast commands to a network of LTC6810-2 devices. This allows the host to quickly disable and re-enable discharging without disturbing register contents. This can be useful, for instance, to allow specific settling time before taking cell measurements. The mute status is reported in the read-only MUTE bit in Status Register Group B.

OPERATION

SERIAL ID

Each LTC6810 is programmed at the factory with a unique 48-bit serial identification code (SID) which is stored in the Serial ID Register Group. The host can read the unique SID code for each device using the RDSID command.

SERIAL INTERFACE OVERVIEW

There are two types of serial ports on the LTC6810: a standard 4-wire serial peripheral interface (SPI) and a 2-wire isolated interface (isoSPI). The state of the ISOMD pin determines whether pins 36, 37, 40 and 41 are a 2-wire or 4-wire serial port.

There are two versions of the IC: the LTC6810-1 and the LTC6810-2. The LTC6810-1 is used in a daisy chain

configuration and the LTC6810-2 is used in an addressable bus configuration. The LTC6810-1 provides a second isoSPI interface using pins 34, 35, 38, and 39. LTC6810-2 uses pins 34, 35, 38 and 39 to set the address of the device, by tying these pins to V^- or V_{REG} .

4-WIRE SERIAL PERIPHERAL INTERFACE (SPI) PHYSICAL LAYER

External Connections

Connecting ISOMD to V^- configures serial port A for 4-wire SPI. The SDO pin is an open drain output which requires a pull-up resistor tied to the appropriate supply voltage (Figure 21).

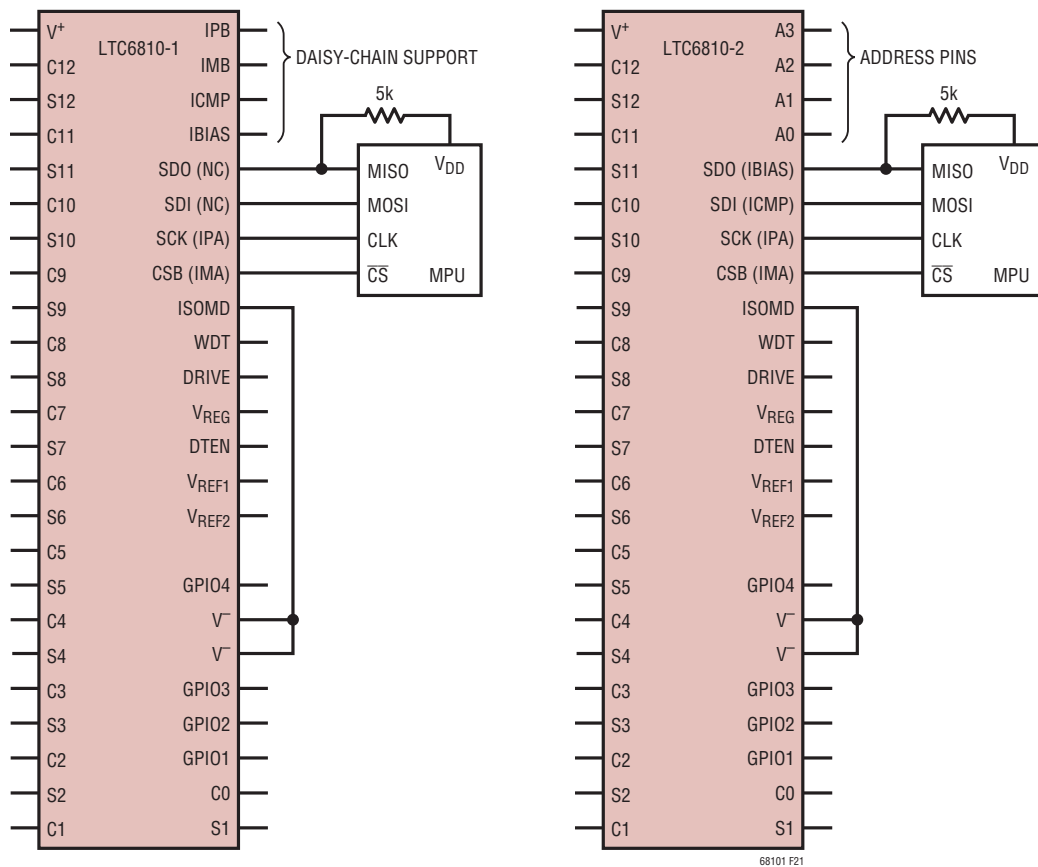

Figure 21. 4-Wire SPI Configuration

OPERATION

Timing

The 4-wire serial port is configured to operate in a SPI system using CPHA = 1 and CPOL = 1. Consequently, data on SDI must be stable during the rising edge of SCK. The timing is depicted in Figure 22. The maximum data rate is 1Mbps.

2-Wire Isolated Interface (isoSPI) Physical Layer

The 2-wire interface provides a means to interconnect LTC6810 devices using simple twisted pair cabling. The interface is designed for low packet error rates when the cabling is subjected to high RF fields. Isolation is achieved through an external transformer.

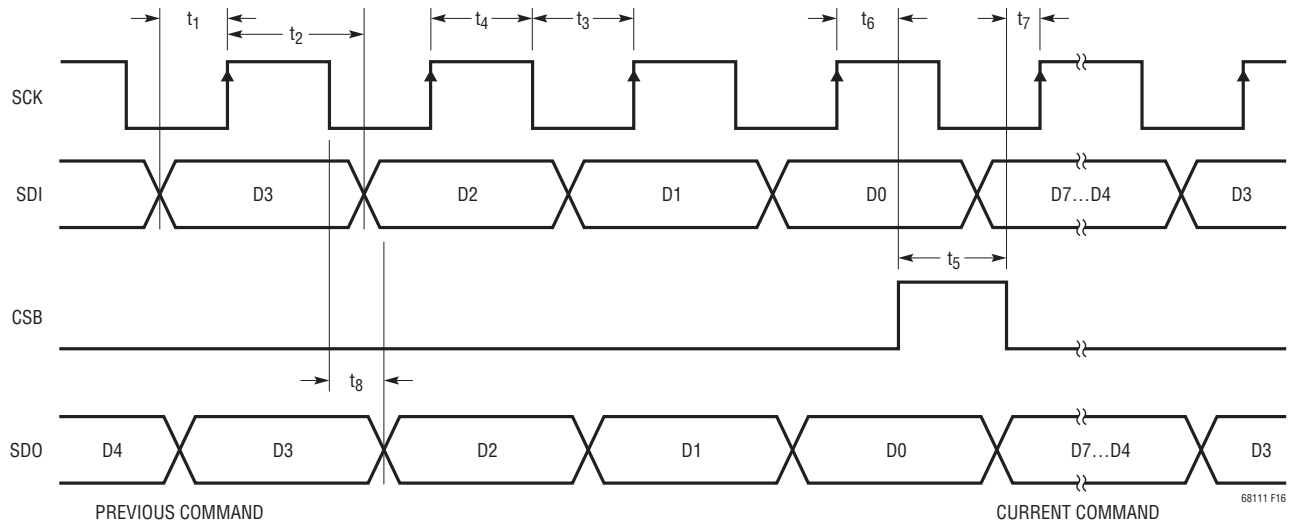

Figure 22. Timing Diagram of 4-Wire Serial Peripheral Interface

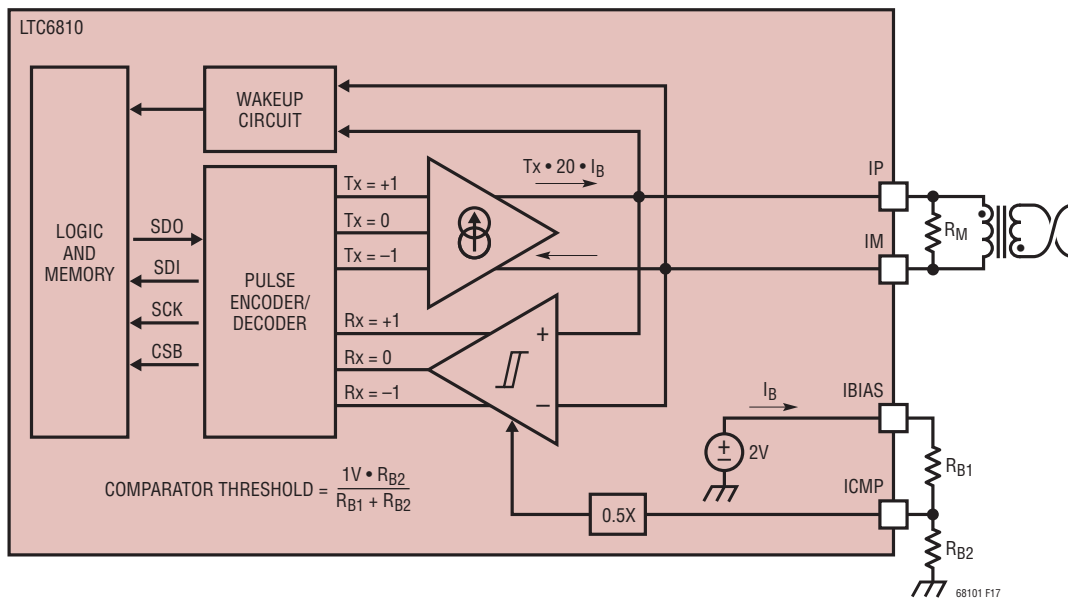

Figure 23. isoSPI Interface

OPERATION

Figure 25 is an example of a robust interconnection of multiple identical PCBs, each containing 1 LTC6810-1. The microprocessor is located on a separate PCB. To achieve 2-wire isolation between the microprocessor PCB and the 1st LTC6810 PCB, use the LTC6820 support IC. The LTC6820 is functionally equivalent to the diagram in Figure 16. In this example, communication is initiated on Port A. So the LTC6810 configures Port A as slave and Port B as master.

Reversible isoSPI for LTC6810-1

Figure 26 illustrates a daisy-chained configuration of LTC6810-1s using reversible isoSPI. LTC6820s are connected on either side of the daisy-chain. Both LTC6820s are configured as Master and share the same SPI interface to connect to the MPU. The MPU uses two CS signals to talk to one of the two LTC6820s.

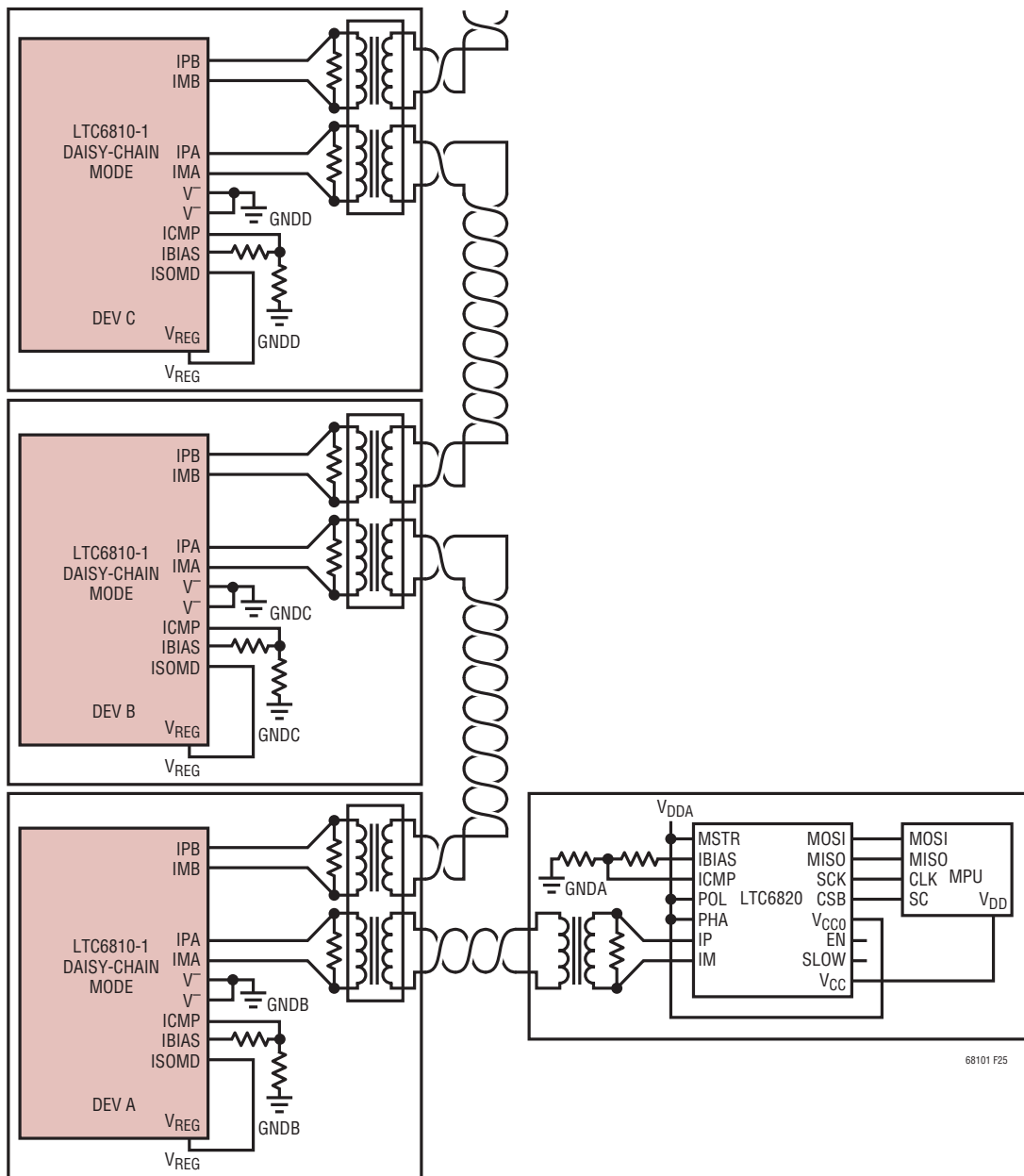

Figure 25. Transformer-Coupled Daisy-Chain Configuration Using LT6810-1

OPERATION

For example, in Figure 26, if the bottom LTC6820 is addressed, then LTC6810 DEV A becomes the first device in the stack followed by DEV B and DEV C. Port A of each LTC6810 is configured as the slave and Port B is configured as the Master. On the other hand, if the top LTC6820 is addressed, then LTC6810 DEV C becomes the first device in the stack followed by DEV B and DEV

A. Port B of each LTC6810 is configured as slave and Port A is configured as Master.

The reversible isoSPI provides a redundant communication path in the event of a single point failure in the 2-wire interface.

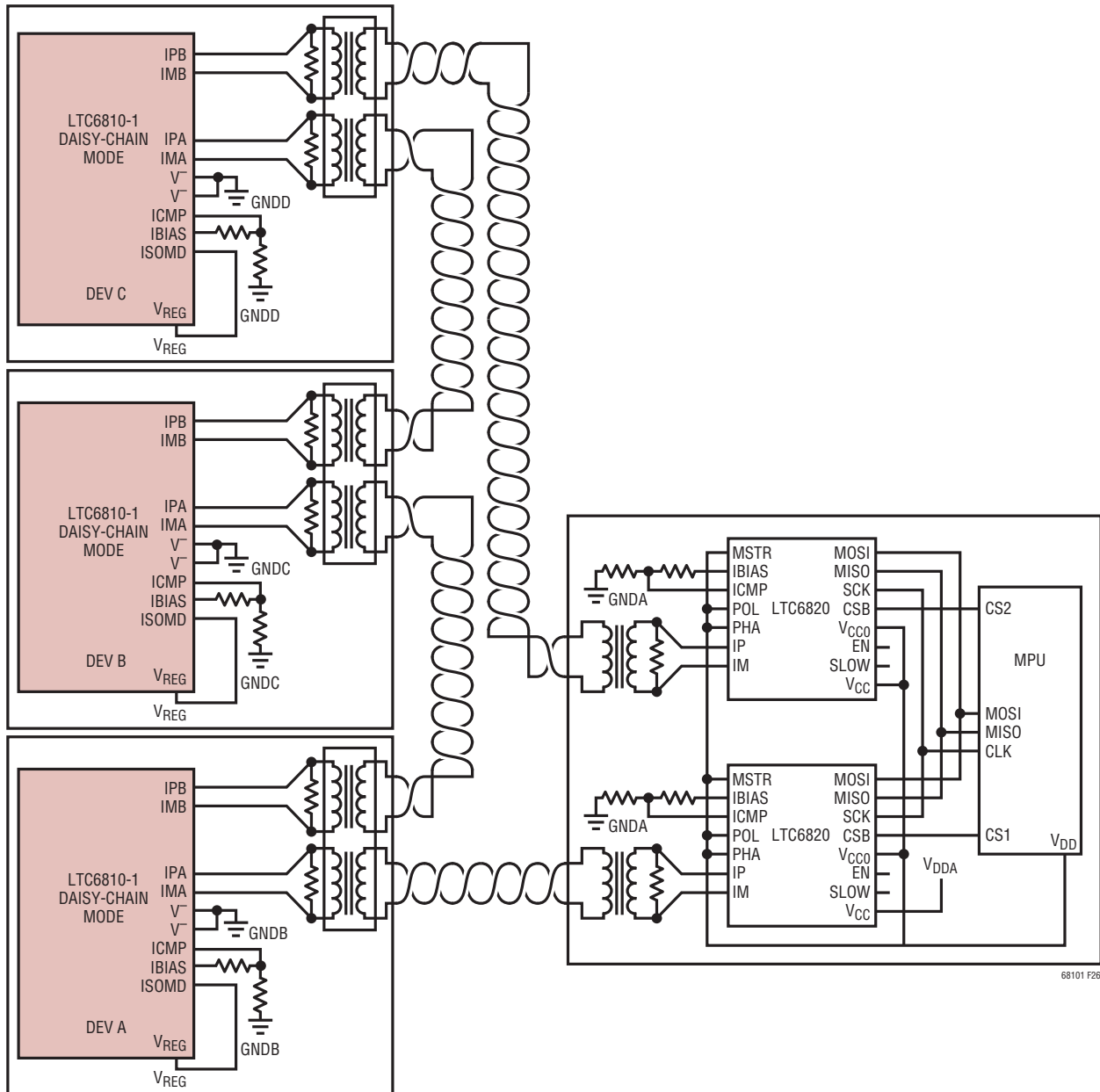

Figure 26. Reversible isoSPI Daisy Chain using the LTC6810-1

LTC6810-1/LTC6810-2

OPERATION

The LTC6810-2 has a single serial port (Port A) which can be 2-wire or 4-wire, depending on the state of the ISOMD pin. When configured for 2-wire communications, several

devices can be connected in a multi-drop configuration, as shown in Figure 27. The LTC6820 IC is used to interface the MPU (master) to the LTC6810-2s (slaves).

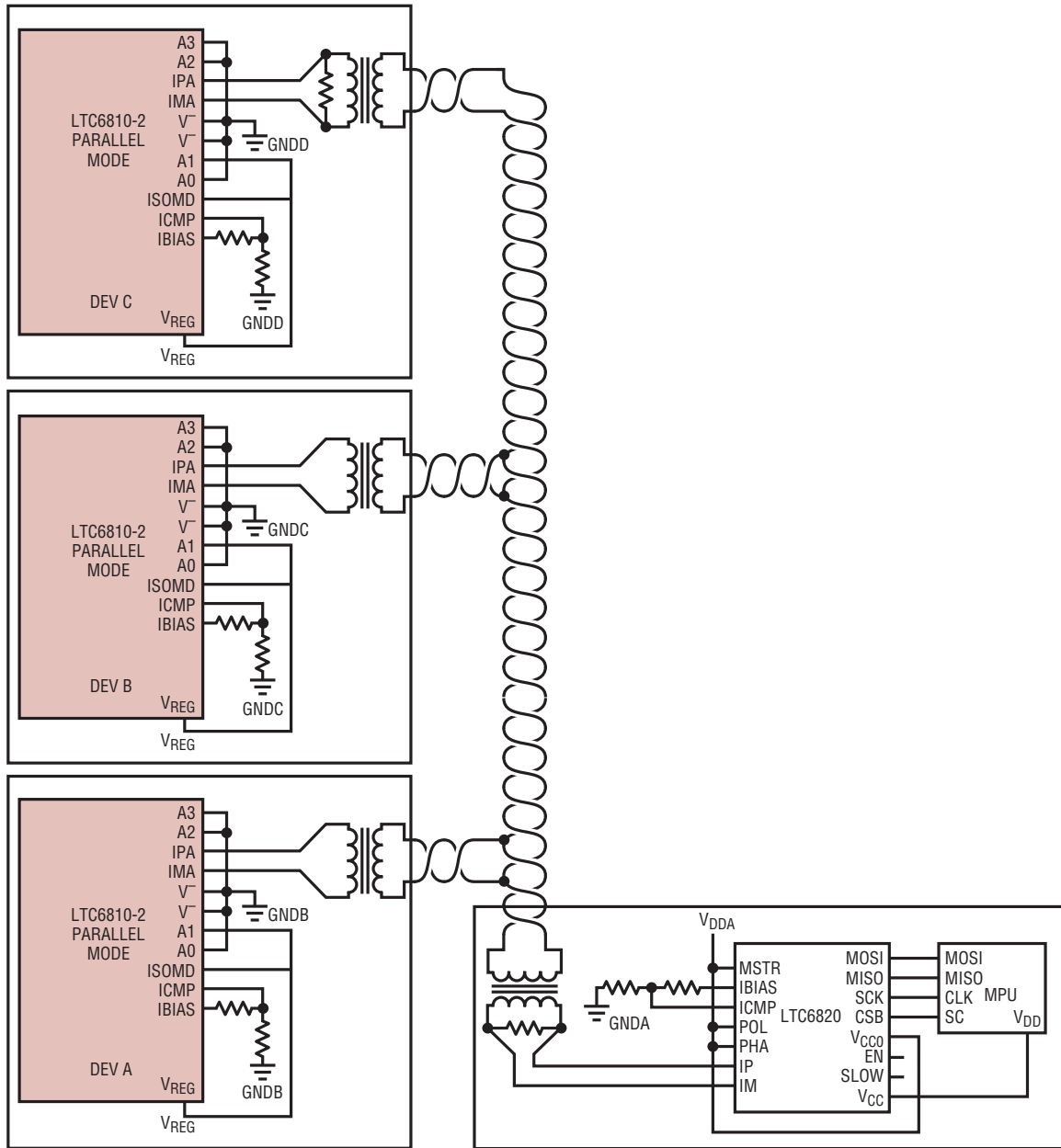

Figure 27. Transformer-Coupled Multi-Drop Configuration Using LTC6810-2

OPERATION

Selecting Bias Resistors

The isoSPI transmitter drive current and comparator voltage threshold are set by a resistor divider ($R_{BIAS} = R_{B1} + R_{B2}$) between the IBIAS and V^- pins. The divided voltage is connected to the ICMP pin, which sets the comparator threshold to $\frac{1}{2}$ of this voltage (V_{ICMP}). When either isoSPI interface is enabled (not IDLE) IBIAS is held at 2V, causing a current I_B to flow out of the IBIAS pin. The IP and IM pin drive currents are $20 \cdot I_B$.

As an example, if divider resistor R_{B1} is 1.78k Ω and resistor R_{B2} is 200 Ω (so that $R_{BIAS} = 2k\Omega$), then:

$$I_B = \frac{2V}{R_{B1} + R_{B2}} = 1mA$$

$$I_{DRV} = I_{IP} = I_{IM} = 20 \cdot I_B = 20mA$$

$$V_{ICMP} = 2V \cdot \frac{R_{B2}}{R_{B1} + R_{B2}} = I_B \cdot R_{B2} = 422mV$$

$$V_{TCMP} = 0.5 \cdot V_{ICMP} = 211mV$$

In this example, the pulse drive current I_{DRV} will be 20mA, and the receiver comparators will detect pulses with IP–IM amplitudes greater than $\pm 211mV$.

If the isolation barrier uses 1:1 transformers connected by a twisted pair and terminated with 100 Ω resistors on each end, then the transmitted differential signal amplitude (\pm) will be:

$$V_A = I_{DRV} \cdot \frac{R_M}{2} = 1V$$

(This result ignores transformer and cable losses, which may reduce the amplitude.)

The adjustable signal amplitude allows the system to trade power consumption for communication robustness, and the adjustable comparator threshold allows the system to account for signal losses.

isoSPI Pulse Detail

Two LTC6810 devices can communicate by transmitting and receiving differential pulses back and forth through an isolation barrier. The transmitter can output three voltage levels: $+V_A$, 0V, and $-V_A$. A positive output results from IP sourcing current and IM sinking current across load resistor R_M . A negative voltage is developed by IP sinking and IM sourcing. When both outputs are off, the load resistance forces the differential output to 0V.

To eliminate the DC signal component and enhance reliability, isoSPI pulses are defined as symmetric pulse pairs. A +1 pulse will be transmitted as a positive pulse followed by a negative pulse. A –1 pulse will be transmitted as a negative pulse followed by a positive pulse. The duration of each pulse is defined as $t_{\frac{1}{2}PW}$, since each is half of the required symmetric pair (the total isoSPI pulse duration is $2 \cdot t_{\frac{1}{2}PW}$).

Table 27. isoSPI Pulse Types

PULSE TYPE	FIRST LEVEL ($t_{\frac{1}{2}PW}$)	SECOND LEVEL ($t_{\frac{1}{2}PW}$)	ENDING LEVEL
Long +1	$+V_A$ (150ns)	$-V_A$ (150ns)	0V
Long –1	$-V_A$ (150ns)	$+V_A$ (150ns)	0V
Short +1	$+V_A$ (50ns)	$-V_A$ (50ns)	0V
Short –1	$-V_A$ (50ns)	$+V_A$ (50ns)	0V

A host microcontroller does not have to generate isoSPI pulses to use this 2-wire interface. The first LTC6810 in the system can communicate to the microcontroller using the 4-wire SPI interface on its Port A, then daisy-chain to other LTC6810s using the 2-wire isoSPI interface on its Port B. Alternatively, the LTC6820 can be used to translate the SPI signals into isoSPI pulses.

Operation with Port A Configured for SPI

When the LTC6810-1 is operation with Port A as a SPI (ISOMD = V^-), the SPI detects one of four communication events: CSB falling, CSB rising, SCK rising with SDI = 0, and SCK rising with SDI = 1. Each event is converted into one of four pulse types for transmission to another daisy-chained LTC6810. Long pulses are used to transmit CSB changes and short pulses transmit data as explained in Table 28.

OPERATION

Table 28. Port B (Master) isoSPI Port Function

COMMUNICATION EVENT (Port A SPI)	TRANSMITTED PULSE (Port B isoSPI)
CS Rising	Long +1
CS Falling	Long -1
SCK Rising Edge, SDI = 1	Short +1
SCK Rising Edge, SDI = 0	Short -1

Table 29. Port A (Slave) isoSPI Port Function

RECEIVED PULSE (Port A isoSPI)	INTERNAL SPI PORT ACTION	RETURN PULSE
Long +1	Drive \overline{CS} High	None
Long -1	Drive \overline{CS} Low	Short -1 Pulse if Reading a 0 bit (No Return Pulse if Not in READ Mode or if Reading a 1 bit)
Short +1	1. Set SDI = 1 2. Pulse SCK	
Short -1	1. Set SDI = 0 2. Pulse SCK	

Operation with Port A Configured for isoSPI

On the other side of the isolation barrier (i.e. at the other end of the cable), the 2nd LTC6810 will have $ISOMD = V_{REG}$. Its Port A operates as a slave isoSPI interface. It receives each transmitted pulse and reconstructs the SPI signals internally, as shown in Table 29. In addition, during a READ command this port may transmit return data pulses.

The slave isoSPI port (slave) never transmits long (CSB) pulses. Furthermore, a slave isoSPI port will only transmit short -1 pulses, never a +1 pulse. The master port recognizes a null response as a logic 1. This allows for multiple slave devices on a single cable without risk of collisions (Multi-drop).

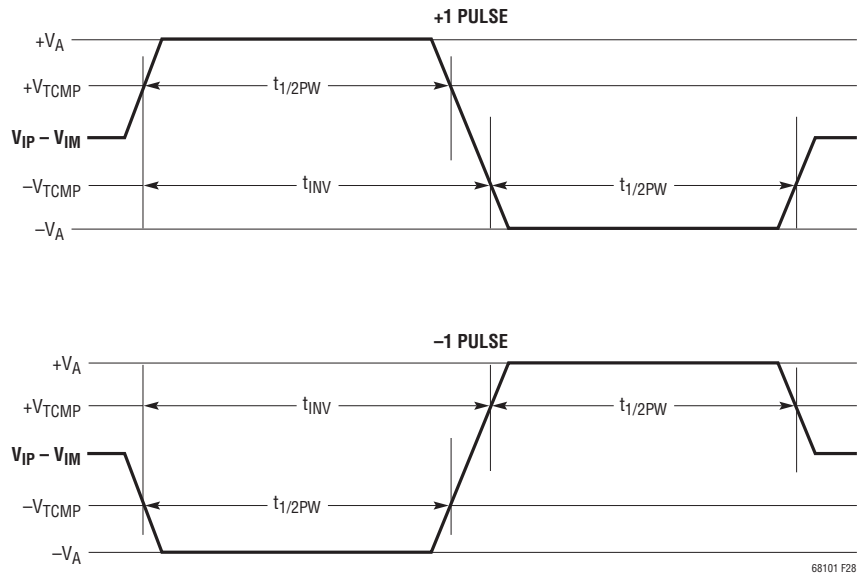

Figure 28. isoSPI Pulse Detail

OPERATION

Timing Diagrams

Figure 29 shows the isoSPI timing diagram for a READ command to daisy chained LTC6810-1 parts. The ISOMD pin is tied to V^- on the bottom part so its Port A is configured as a SPI port (CSB, SCK, SDI and SDO). The isoSPI signals of three stacked devices are shown labeled with the port (A or B) and part number. Note that ISO B1 and ISO A2 is actually the same signal, but shown on each end of the transmission cable that connects Parts 1 and 2. Likewise, ISO B2 and ISO A3 is the same signal, but with the cable delay shown between Parts 2 and 3.

Bits W_N-W_0 refers to the 16 bit command code and the 16 bit PEC of a READ command. At the end of bit W_0 the 3 parts decode the READ command and begin shifting out data which is valid on the next rising edge of clock SCK. Bits X_N-X_0 refer to the data shifted out by Part 1. Bits Y_N-Y_0 refer to the data shifted out by Part 2 and bits Z_N-Z_0 refer to the data shifted out by Part 3. All this data is read back from the SDO port on Part 1 in a daisy-chained fashion.

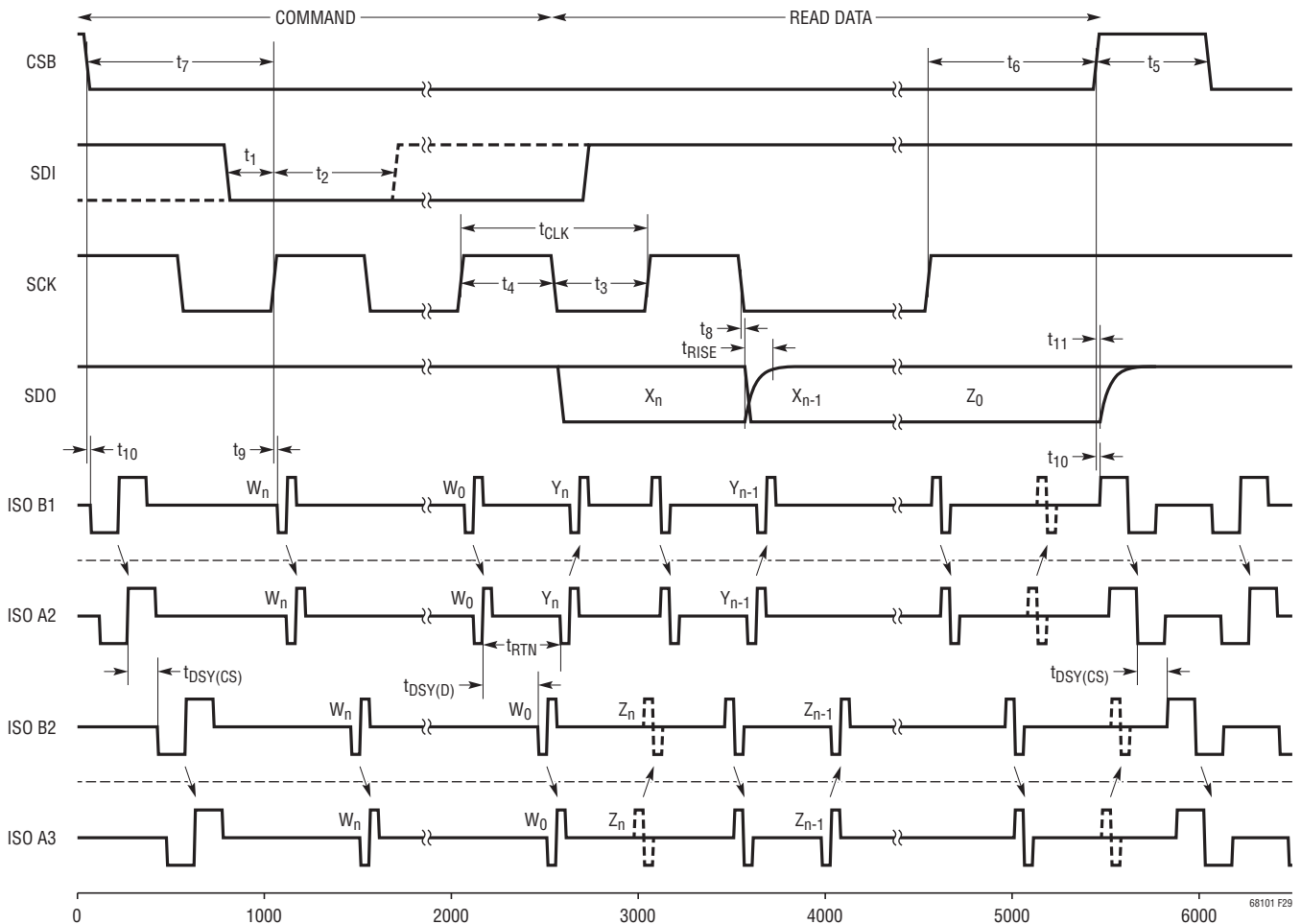

Figure 29. isoSPI Timing Diagram

OPERATION

Waking up the Serial Interface

The serial ports (SPI or isoSPI) will enter the low power IDLE state if there is no activity on Port A or Port B for a time of t_{IDLE} . The WAKEUP circuit monitors activity on pins 36 and 37, which are CSB and SCK if ISOMD is low, or IPA and IMA if ISOMD is high, and activity on pins 38 and 39, which are IMB and IPB for LTC6810-1 and A2 and A3 for LTC6810-2.

If $ISOMD = V^-$, Port A is in SPI mode. Activity on the CSB or SCK pin will wake up the SPI interface. If $ISOMD = V_{REG}$, Port A is in isoSPI mode. Differential activity on IPA–IMA or IPB–IMB wakes up the isoSPI interface. The LTC6810 will be ready to communicate when the isoSPI state changes to READY within t_{WAKE} or t_{READY} , depending on the Core state (see Figure 1 and state descriptions for details).

Figure 30 illustrates the timing and the functionally equivalent circuit. The wake-up circuit responds to the difference between SCK(IPA) and CS(IMA). Common mode signals will not wake up the serial interface. The interface is designed to wake up after receiving a large signal single-ended pulse, or a low-amplitude symmetric pulse. The differential signal $|SCK(IPA) - CS(IMA)|$, must be at least $V_{WAKE} = 200mV$ for a minimum duration of $t_{DWELL} = 240ns$ to qualify as a wake up signal that powers up the serial interface.

Waking a Daisy Chain — Method 1

The LTC6810-1 sends a long +1 pulse on Port B after it is ready to communicate. In a daisy-chained configuration, this pulse wakes up the next device in the stack which will, in turn, wake up the next device. If there are ‘N’ devices in the stack, all the devices are powered up within the time $N \cdot t_{WAKE}$ or $N \cdot t_{READY}$, depending on the Core state. For large stacks, the time $N \cdot t_{WAKE}$ may be equal to or larger than t_{IDLE} . In this case, after waiting longer than the time of $N \cdot t_{WAKE}$, the host may send another dummy byte and wait for the time $N \cdot t_{READY}$, in order to ensure that all devices are in the READY state.

Method 1 can be used when all devices on the daisy chain are in the IDLE state. This guarantees that they propagate the wake-up signal up the daisy chain. However, this method will fail to wake up all devices when a device in the middle of the chain is in the READY state instead of IDLE. When this happens, the device in READY state will not propagate the wake-up pulse, so the devices above it will remain IDLE. This situation can occur when attempting to wake up the daisy chain after only t_{IDLE} of idle time (some devices may be IDLE, some may not).

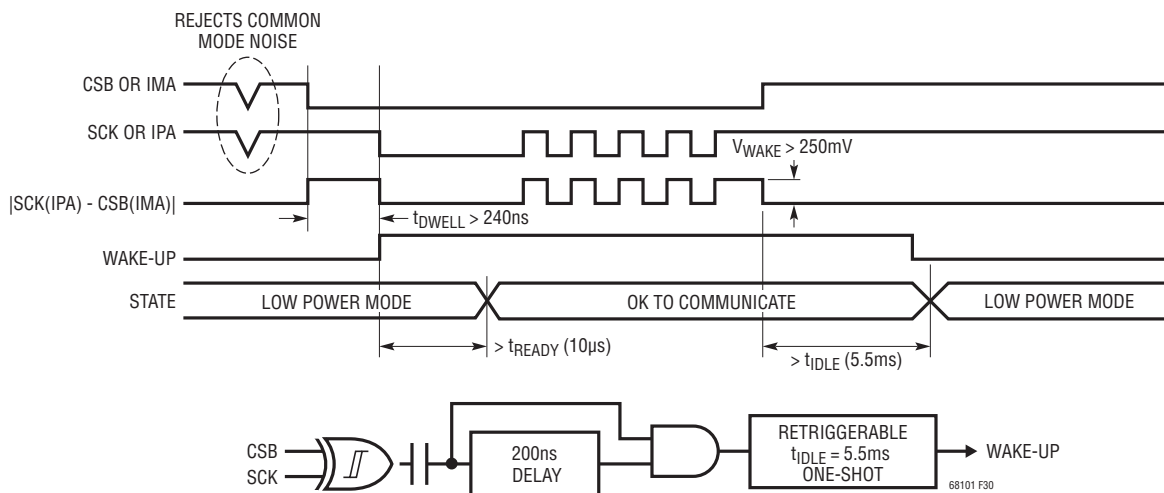

Figure 30. Wake-up Detection and IDLE Timer

OPERATION

Waking a Daisy Chain — Method 2

A more robust wake-up method does not rely on the built-in wake-up pulse, but manually sends isoSPI traffic for enough time to wake the entire daisy chain. At minimum, a pair of long isoSPI pulses (–1 and +1) is needed for each device, separated by more than t_{READY} or t_{WAKE} (if the Core state is STANDBY or SLEEP, respectively), but less than t_{IDLE} . This allows each device to wake up and propagate the next pulse to the following device. This method works even if some devices in the chain are not in the IDLE state. In practice, implementing method 2 requires toggling the CSB pin (of the LTC6820, or bottom LTC6810 with ISOMD = 0) to generate the long isoSPI pulses. Alternatively, dummy commands (such as RDCFG) can be executed to generate the long isoSPI pulses.

DATA LINK LAYER

All Data transfers on LTC6810 occur in byte groups. Every byte consists of 8 bits. Bytes are transferred with the most significant bit (MSB) first. CSB must remain low for the entire duration of a command sequence, including between a command byte and subsequent data. On a write command, data is latched in on the rising edge of CSB.

NETWORK LAYER

Packet Error Code

The packet error code (PEC) is a 15-bit cyclic redundancy check (CRC) value calculated for all of the bits in a register group in the order they are passed, using the initial PEC value of 00000000010000 and the following characteristic polynomial: $x^{15} + x^{14} + x^{10} + x^8 + x^7 + x^4 + x^3 + 1$.

To calculate the 15-bit PEC value, a simple procedure can be established:

1. Initialize the PEC to 00000000010000 (PEC is a 15 bit register group)
2. For each bit DIN coming into the PEC register group, set
 - IN0 = DIN XOR PEC [14]
 - IN3 = IN0 XOR PEC [2]
 - IN4 = IN0 XOR PEC [3]
 - IN7 = IN0 XOR PEC [6]
 - IN8 = IN0 XOR PEC [7]
 - IN10 = IN0 XOR PEC [9]
 - IN14 = IN0 XOR PEC [13]
3. Update the 15-bit PEC as follows
 - PEC [14] = IN14,
 - PEC [13] = PEC [12],
 - PEC [12] = PEC [11],
 - PEC [11] = PEC [10],
 - PEC [10] = IN10,
 - PEC [9] = PEC [8],
 - PEC [8] = IN8,
 - PEC [7] = IN7,
 - PEC [6] = PEC [5],
 - PEC [5] = PEC [4],
 - PEC [4] = IN4,
 - PEC [3] = IN3,
 - PEC [2] = PEC [1],
 - PEC [1] = PEC [0],
 - PEC [0] = IN0
4. Go back to step 2 until all the data is shifted. The final PEC (16 bits) is the 15 bit value in the PEC register with a 0 bit appended to its LSB

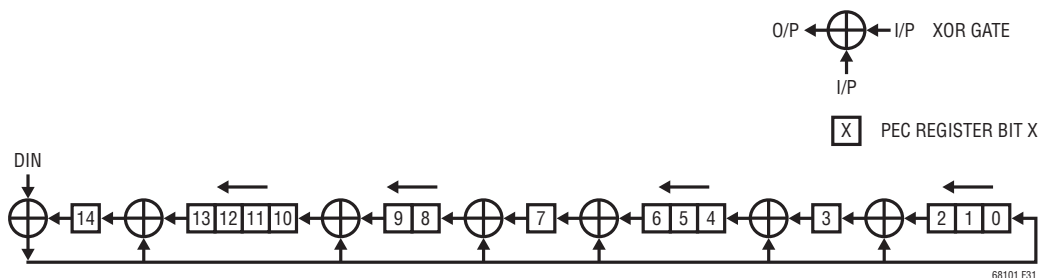

Figure 31.

LTC6810-1/LTC6810-2

OPERATION

Figure 31 illustrates the algorithm described above. An example to calculate the PEC for a 16 bit word (0x0001) is listed in Table 30. The PEC for 0x0001 is computed as 0x3D6E after stuffing a 0 bit at the LSB. For longer data streams, the PEC is valid at the end of the last bit of data sent to the PEC register.

LTC6810 calculates PEC for any command or data received and compares it with the PEC following the command or data. The command or data is regarded as valid only if the PEC matches. LTC6810 also attaches the calculated PEC at the end of the data it shifts out. Table 31 shows the format of PEC while writing to or reading from LTC6810.

Table 30. PEC Calculation for 0x0001

PEC[14]	0	0	0	0	0	0	0	0	0	0	1	1	1	1	1	0	0	0
PEC[13]	0	0	0	0	0	0	0	0	0	1	0	0	0	0	1	1	0	0
PEC[12]	0	0	0	0	0	0	0	0	1	0	0	0	0	1	1	0	1	1
PEC[11]	0	0	0	0	0	0	0	1	0	0	0	0	1	1	0	1	1	1
PEC[10]	0	0	0	0	0	0	1	0	0	0	0	1	1	0	1	1	1	1
PEC[9]	0	0	0	0	0	1	0	0	0	0	0	0	1	0	0	0	1	1
PEC[8]	0	0	0	0	1	0	0	0	0	0	0	1	0	0	0	1	0	0
PEC[7]	0	0	0	1	0	0	0	0	0	0	0	1	1	1	0	1	1	1
PEC[6]	0	0	1	0	0	0	0	0	0	0	0	0	0	1	0	0	0	0
PEC[5]	0	1	0	0	0	0	0	0	0	0	0	0	1	0	0	0	1	1
PEC[4]	1	0	0	0	0	0	0	0	0	0	0	1	0	0	0	1	1	1
PEC[3]	0	0	0	0	0	0	0	0	0	0	0	1	1	1	0	0	0	0
PEC[2]	0	0	0	0	0	0	0	0	0	0	0	0	0	1	1	1	1	1
PEC[1]	0	0	0	0	0	0	0	0	0	0	0	1	1	1	1	1	1	1
PEC[0]	0	0	0	0	0	0	0	0	0	0	0	1	1	1	1	1	1	1
IN14	0	0	0	0	0	0	0	0	0	1	1	1	1	1	0	0		0
IN10	0	0	0	0	0	1	0	0	0	0	1	1	0	1	1	1		PEC word
IN8	0	0	0	1	0	0	0	0	0	0	1	0	0	0	1	0		
IN7	0	0	1	0	0	0	0	0	0	0	1	1	1	0	1	1		
IN4	0	0	0	0	0	0	0	0	0	0	1	0	0	0	1	1		
IN3	0	0	0	0	0	0	0	0	0	0	1	1	1	0	0	0		
IN0	0	0	0	0	0	0	0	0	0	0	1	1	1	1	1	1		
DIN	0	0	0	0	0	0	0	0	0	0	0	0	0	0	0	1		
Clock Cycle	0	1	2	3	4	5	6	7	8	9	10	11	12	13	14	15	16	

Table 31. Write/Read PEC format

Name	RD/WR	Bit 7	Bit 6	Bit 5	Bit 4	Bit 3	Bit 2	Bit 1	Bit 0
PEC0	RD/WR	PEC[14]	PEC[13]	PEC[12]	PEC[11]	PEC[10]	PEC[9]	PEC[8]	PEC[7]
PEC1	RD/WR	PEC[6]	PEC[5]	PEC[4]	PEC[3]	PEC[2]	PEC[1]	PEC[0]	0

OPERATION

While writing any command to LTC6810, the command bytes CMD0 and CMD1 (see Table 38 and Table 39) and the PEC bytes PEC0 and PEC1 are sent on Port A in the following order:

CMD0, CMD1, PEC0, PEC1

After a broadcast write command to daisy chained LTC6810-1 devices, data is sent to each device followed by the PEC. For example, when writing the Configuration Register Group to two daisy-chained devices (primary device P, stacked device S), the data will be sent to the primary device on its slave port in the following order:

CFGR0(S), ..., CFGR5(S), PEC0(S), PEC1(S),
CFGR0(P), ..., CFGR5(P), PEC0(P), PEC1(P)

After a read command for daisy chained devices, each device shifts out its data and the PEC that it computed for its data on its slave port followed by the data received on its master port. For example, when reading Status Register Group B from two daisy-chained devices (primary device P, stacked device S), the primary device sends out data on its slave port in the following order:

STBR0(P), ..., STBR5(P), PEC0(P), PEC1(P),
STBR0(S), ..., STBR5(S), PEC0(S), PEC1(S)

Address Commands (LTC6810-2 Only)

An address command is one in which only the addressed device on the bus responds. Address commands are used only with LTC6810-2 parts. All commands are compatible with addressing. See the Bus Protocols section for Address command format.

Broadcast Commands (LTC6810-1 or LTC6810-2)

A broadcast command is one to which all devices on the bus will respond, regardless of device address. This command can be used with LTC6810-1 and LTC6810-2 parts. See the Bus Protocols section for Broadcast command format. With broadcast commands all devices can be sent commands simultaneously.

In parallel (LTC6810-2) configurations, broadcast commands are useful for initiating ADC conversions or for sending write commands when all parts are being written with the same data. The polling function (automatic at the end of ADC commands, or manual using the PLADC command) can also be used with broadcast commands, but not with parallel isoSPI devices. Likewise, broadcast read commands should not be used in the parallel configuration (either SPI or isoSPI).

Daisy-chained (LTC6810-1) configurations support broadcast commands only, because they have no addressing. All devices in the chain receive the command bytes simultaneously. For example, to initiate ADC conversions in a stack of devices, a single ADCV command is sent, and all devices will start conversions at the same time. For read and write commands, a single command is sent, and then the stacked devices effectively turn into a cascaded shift register, in which data is shifted through each device to the next higher (on a write) or the next lower (on a read) device in the stack. See the Serial Interface Overview section.

Polling Methods

The simplest method to determine ADC completion is for the controller to start an ADC conversion and wait for the specified conversion time to pass before reading the results. Both LTC6810-1 and LTC6810-2 also allow polling to determine ADC completion.

In parallel configurations that communicate in SPI mode (ISOMD pin tied low), there are two methods of polling. The first method is to hold CSBI low after an ADC conversion command is sent. After entering a conversion command, the SDO line is driven low when the device is busy performing conversions. SDO is pulled high when the device completes conversions. However, the SDO will also go back high when CSBI goes high even if the device has not completed the conversion (Figure 32). An addressed device drives the SDO line based on its status alone. A problem with this method is that the controller is not free to do other serial communication while waiting for ADC conversions to complete.

OPERATION

The next method overcomes this limitation. The controller can send an ADC start command, perform other tasks, and then send a poll ADC converter status (PLADC) command to determine the status of the ADC conversions (Figure 33). After entering the PLADC command, SDO will go low if the device is busy performing conversions. SDO is pulled high at the end of conversions. However, the SDO will also go high when CSBI goes high even if the device has not completed the conversion.

In parallel configurations that communicate in isoSPI mode, the low side port transmits a data pulse only in response to a master isoSPI pulse received by it. So, after entering the command in either method of polling described above, isoSPI data pulses are sent to the part to update the conversion status. These pulses can be sent using LTC6820 by simply clocking its SCK pin. In response to this pulse, the device sends back a low isoSPI pulse if it is still busy performing conversions or a high data pulse if it has completed the conversions. If a CSB high isoSPI pulse is sent to the device, it exits the polling command.

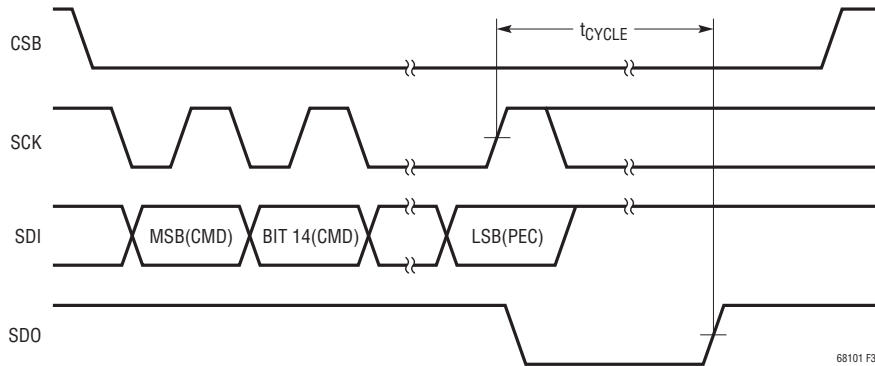

Figure 32. SDO Polling After an ADC Conversion Command (Parallel Configuration)

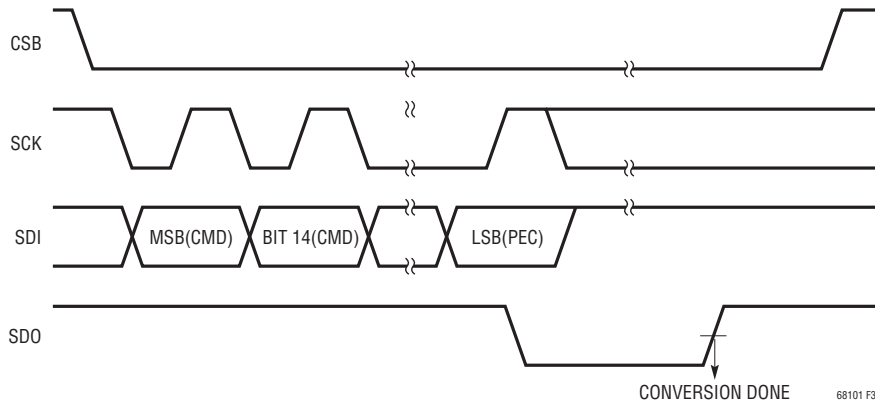

Figure 33. SDO Polling Using PLADC Command (Parallel Configuration)

OPERATION

In a daisy-chained configuration of N stacked devices, the same two polling methods can be used. If the bottom device communicates in SPI mode, the SDO of the bottom device indicates the conversion status of the entire stack (i.e. SDO will remain low until all the devices in the stack have completed conversions). In the first method of polling, after an ADC conversion command is sent, clock pulses are sent on SCK while keeping CSB low. The SDO status becomes valid only at the end of N clock pulses on SCK and gets updated for every clock pulse that follows (Figure 34). In the second method, the PLADC command is sent followed by clock pulses on SCK while keeping

CSB low. Similar to the first method, the SDO status is valid only after N clock cycles on SCK and gets updated after every clock cycle that follows (Figure 35).

If the bottom device communicates in isoSPI mode, isoSPI data pulses are sent to the device to update the conversion status. Using LTC6820, this can be achieved by just clocking its SCK pin. The conversion status is valid only after the bottom LTC6810 device receives N isoSPI data pulses and the status gets updated for every isoSPI data pulse that follows. The device returns a low data pulse if any of the devices in the stack is busy performing conversions and returns a high data pulse if all the devices are free.

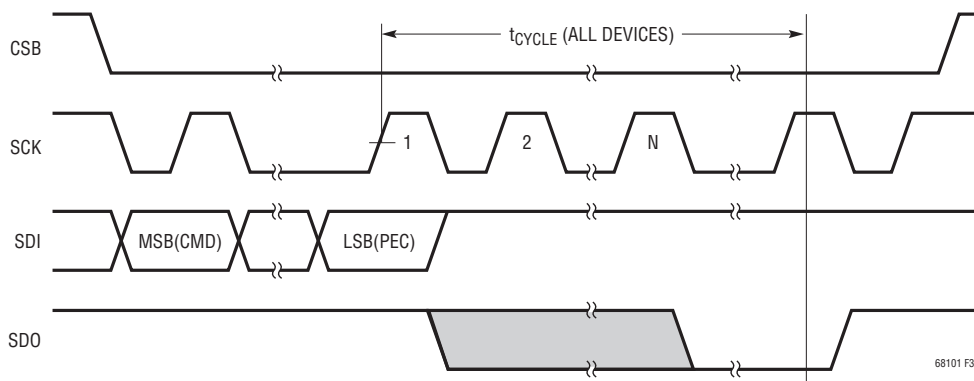

Figure 34.

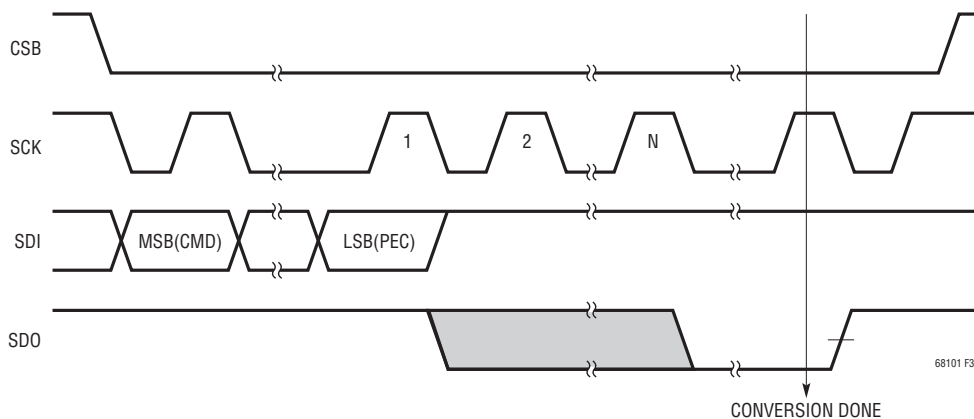

Figure 35.

OPERATION

Bus Protocols

Protocol Format: The protocol formats for both broadcast and address commands are depicted in Table 33 through Table 37. Table 32 is the key for reading the protocol diagrams.

Table 32. Protocol Key

CMD0	Command Byte 0 (See Table 38 and Table 39)
CMD1	Command Byte 1 (See Table 38 and Table 39)
PEC0	Packet Error Code Byte 0 (See Table 31)
PEC1	Packet Error Code Byte 1 (See Table 31)
<i>N</i>	Number of Bytes
...	Continuation of Protocol
	Master to Slave
	Slave to Master

Command Format: The formats for the broadcast and address commands are shown in Table 38 and Table 39 respectively. The 11 bit command code CC[10:0] is the same for a broadcast or an address command. A list of all the command codes is shown in Table 40. A broadcast command has a value 0 for CMD0[7] through CMD0[3]. An address command has a value 1 for CMD0[7] followed by the 4 bit address of the device (a3, a2, a1, a0) in bits CMD0[6:3]. An addressed device will respond to an address command only if the physical address of the device on pins A3 to A0 match the address specified in the address command. The PEC for broadcast and address commands must be computed on the entire 16 bit command (CMD0 and CMD1).

Table 33. Broadcast/Address Poll Command

8	8	8	8	
CMD0	CMD1	PEC0	PEC1	Poll Data

Table 34. Broadcast Write Command

8	8	8	8	8	...	8	8	8	8	...	8
CMD0	CMD1	PEC0	PEC1	Data Byte Low	...	Data Byte High	PEC0	PEC1	Shift Byte 1	...	Shift Byte <i>n</i>

Table 35. Address Write Command

8	8	8	8	8	...	8	8	8
CMD0	CMD1	PEC0	PEC1	Data Byte Low	...	Data Byte High	PEC0	PEC1

Table 36. Broadcast Read Command

8	8	8	8	8	...	8	8	8	8	...	8
CMD0	CMD1	PEC0	PEC1	Data Byte Low	...	Data Byte High	PEC0	PEC1	Shift Byte 1	...	Shift Byte <i>n</i>

Table 37. Address Read Command

8	8	8	8	8	...	8	8	8
CMD0	CMD1	PEC0	PEC1	Data Byte Low	...	Data Byte High	PEC0	PEC1

Table 38. Broadcast Command Format

NAME	RD/WR	BIT 7	BIT 6	BIT 5	BIT 4	BIT 3	BIT 2	BIT 1	BIT 0
CMD0	WR	0	0	0	0	0	CC[10]	CC[9]	CC[8]
CMD1	WR	CC[7]	CC[6]	CC[5]	CC[4]	CC[3]	CC[2]	CC[1]	CC[0]

Table 39. Address Command Format

NAME	RD/WR	BIT 7	BIT 6	BIT 5	BIT 4	BIT 3	BIT 2	BIT 1	BIT 0
CMD0	WR	1	a3*	a2*	a1*	a0*	CC[10]	CC[9]	CC[8]
CMD1	WR	CC[7]	CC[6]	CC[5]	CC[4]	CC[3]	CC[2]	CC[1]	CC[0]

*ax is Address Bit x

OPERATION

Commands

Table 40 lists all the commands and its options for both LTC6810-1 and LTC6810-2.

Table 40. Command Codes

COMMAND DESCRIPTION	NAME	CC[10:0] — COMMAND CODE										
		10	9	8	7	6	5	4	3	2	1	0
Write Configuration Register Group	WRCFG	0	0	0	0	0	0	0	0	0	0	1
Read Configuration Register Group	RDCFG	0	0	0	0	0	0	0	0	0	1	0
Write Control Register Group (PWM and S)	WRCTRL*	0	0	0	0	0	0	1	0	1	0	0
Read Control Register Group (PWM and S)	RDCCTRL*	0	0	0	0	0	0	1	0	1	1	0
Write PWM Register Group (PWM and S)	WRPWM*	0	0	0	0	0	1	0	0	0	0	0
Read PWM Register Group (PWM and S)	RDPWM*	0	0	0	0	0	1	0	0	0	1	0
Read Cell Voltage Register Group A	RDCVA	0	0	0	0	0	0	0	0	1	0	0
Read Cell Voltage Register Group B	RDCVB	0	0	0	0	0	0	0	0	1	1	0
Read S Voltage Register Group A	RDSA	0	0	0	0	0	0	0	1	0	0	0
Read S Voltage Register Group B	RDSB	0	0	0	0	0	0	0	1	0	1	0
Read Auxiliary Register Group A	RDAUXA	0	0	0	0	0	0	0	1	1	0	0
Read Auxiliary Register Group B	RDAUXB	0	0	0	0	0	0	0	1	1	1	0
Read Status Register Group A	RDSTATA	0	0	0	0	0	0	1	0	0	0	0
Read Status Register Group B	RDSTATB	0	0	0	0	0	0	1	0	0	1	0
Read Serial ID Register Group	RDSID	0	0	0	0	0	1	0	1	1	0	0
Start Cell Voltage ADC Conversion and Poll Status	ADCV	0	1	MD[1]	MD[0]	1	1	DCP	0	CH[2]	CH[1]	CH[0]
Start Open Wire ADC Conversion and Poll Status	ADOW	0	1	MD[1]	MD[0]	PUP	1	DCP	1	CH[2]	CH[1]	CH[0]
Start Self-Test Cell Voltage Conversion and Poll Status	CVST	0	1	MD[1]	MD[0]	ST[1]	ST[0]	0	0	1	1	1
Start GPIOs/Cell 0/REF2 ADC Conversion and Poll Status	ADAX	1	0	MD[1]	MD[0]	1	1	0	0	CHG[2]	CHG[1]	CHG[0]
Start GPIOs/Cell 0/REF2 ADC Conversion with Digital Redundancy and Poll Status	ADAXD	1	0	MD[1]	MD[0]	0	0	0	0	CHG[2]	CHG[1]	CHG[0]

LTC6810-1/LTC6810-2

OPERATION

COMMAND DESCRIPTION	NAME	CC[10:0] — COMMAND CODE										
		10	9	8	7	6	5	4	3	2	1	0
Start GPIOs/Cell 0/REF2 ADC Open Wire Conversion	AXOW	1	0	MD[1]	MD[0]	PUP	0	1	0	CHG[2]	CHG[1]	CHG[0]
Start Self-Test GPIOs/Cell 0/REF2 Conversion and Poll Status	AXST	1	0	MD[1]	MD[0]	ST[1]	ST[0]	0	0	1	1	1
Start Status Group ADC Conversion and Poll Status	ADSTAT	1	0	MD[1]	MD[0]	1	1	0	1	CHST[2]	CHST[1]	CHST[0]
Start Status Group ADC Conversion with Digital Redundancy and Poll Status	ADSTATD	1	0	MD[1]	MD[0]	0	0	0	1	CHST[2]	CHST[1]	CHST[0]
Start Self-Test Status Group Conversion and Poll Status	STATST	1	0	MD[1]	MD[0]	ST[1]	ST[0]	0	1	1	1	1
Start Combined Cell Voltage and Cell 0, GPIO1 Conversion and Poll Status	ADCVAX	1	0	MD[1]	MD[0]	1	1	DCP	1	1	1	1
Start Combined Cell Voltage and SC Conversion and Poll Status	ADCVSC	1	0	MD[1]	MD[0]	1	1	DCP	0	1	1	1
Clear Cell Voltage Register Group	CLRCELL	1	1	1	0	0	0	1	0	0	0	1
Clear Auxiliary Register Group	CLRAUX	1	1	1	0	0	0	1	0	0	1	0
Clear Status Register Group	CLRSTAT	1	1	1	0	0	0	1	0	0	1	1
Poll ADC Conversion Status	PLADC	1	1	1	0	0	0	1	0	1	0	0
Diagnose MUX and Poll Status	DIAGN	1	1	1	0	0	0	1	0	1	0	1
Write COMM Register Group	WRCOMM	1	1	1	0	0	1	0	0	0	0	1
Read COMM Register Group	RDCOMM	1	1	1	0	0	1	0	0	0	1	0
Start I ² C/SPI Communication	STCOMM	1	1	1	0	0	1	0	0	0	1	1
Mute Discharge	MUTE	0	0	0	0	0	1	0	1	0	0	0
Unmute Discharge	UNMUTE	0	0	0	0	0	1	0	1	0	0	1

*The WRSCTRL and WRPWM and RDSCTRL and RDPWM commands all access the same PWM Register Group. The WRSCTRL and RDSCTRL commands are provided for compatibility with other LTC681x devices in a daisy-chain.

Table 41. Command Bit Descriptions

NAME	DESCRIPTION	VALUES		
MD[1:0]	ADC Mode	MD	ADCOPT(CFGR0[0]) = 0	ADCOPT(CFGR0[0]) = 1
		00	422Hz Mode	1kHz Mode
		01	27 kHz Mode (Fast)	14 kHz Mode
		10	7 kHz Mode (Normal)	3 kHz Mode
		11	26 Hz Mode (Filtered)	2 kHz Mode

OPERATION

NAME	DESCRIPTION	VALUES									
DCP	Discharge Permitted	DCP									
		0	Discharge Not Permitted								
		1	Discharge Permitted								
CH[2:0]	Cell Selection for ADC Conversion		Total Conversion Time in 8 ADC Modes								
		CH	27kHz	14kHz	7kHz	3kHz	2kHz	1kHz	422Hz	26Hz	
		000	All Cells	524µs	699µs	1.2ms	1.9ms	3.3ms	6.1ms	12ms	201ms
		001	Cell 1	200µs	229µs	404µs	520µs	753µs	1.2ms	2.1ms	34ms
		010	Cell 2								
		011	Cell 3								
		100	Cell 4								
		101	Cell 5								
110	Cell 6										
PUP	Pull-Up/Pull-Down Current for Open Wire Conversions	PUP									
		0	Pull-Down Current								
		1	Pull-Up Current								
ST[1:0]	Self Test Mode Selection		Self Test Conversion Result								
		ST	27kHz	14kHz	7kHz	3kHz	2kHz	1kHz	422Hz	26Hz	
		01	Self Test 1	0x9565	0x9553	0x9555	0x9555	0x9555	0x9555	0x9555	0x9555
		10	Self test 2	0x6A9A	0x6AAC	0x6AAA	0x6AAA	0x6AAA	0x6AAA	0x6AAA	0x6AAA
CHG[2:0]	GPIO Selection for ADC Conversion		Total Conversion Time in the 8 ADC Modes								
		CHG	27kHz	14kHz	7kHz	3kHz	2kHz	1kHz	422Hz	26Hz	
		000	S0, GPIO 1–4, 2nd Reference	521µs	695µs	1.2ms	1.9ms	3.3ms	6.0ms	12ms	183ms
		001	S0	200µs	229µs	403µs	520µs	752µs	1.2ms	2.1ms	34ms
		010	GPIO 1								
		011	GPIO 2								
		100	GPIO 3								
		101	GPIO 4								
110	2nd Reference										
CHST[2:0]*	Status Group Selection		Total Conversion Time in 8 ADC Modes								
		CHST	27kHz	14kHz	7kHz	3kHz	2kHz	1kHz	422Hz	26Hz	
		000	SOC, ITMP, VA, VD	741µs	858µs	1.6ms	2.0ms	3.0ms	4.8ms	8.5ms	134ms
		001	SC	200µs	229µs	403µs	520µs	752µs	1.2ms	2.1ms	34ms
		010	ITMP								
		011	VA								
		100	VD								

*Note: Valid options for CHST in ADSTAT command are 0–4. If CHST is set to 5/6 in ADSTAT command, the LTC6810 treats it like ADAX command with CHG =5/6.

OPERATION

Memory Map

Table 42. Configuration Register Group

REGISTER	RD/WR	BIT 7	BIT 6	BIT 5	BIT 4	BIT 3	BIT 2	BIT 1	BIT 0
CFGRO	RD/WR	RSVD	GPIO4	GPIO3	GPIO2	GPIO1	REFON	DTEN	ADCOPT
CFGR1	RD/WR	VUV[7]	VUV[6]	VUV[5]	VUV[4]	VUV[3]	VUV[2]	VUV[1]	VUV[0]
CFGR2	RD/WR	VOV[3]	VOV[2]	VOV[1]	VOV[0]	VUV[11]	VUV[10]	VUV[9]	VUV[8]
CFGR3	RD/WR	VOV[11]	VOV[10]	VOV[9]	VOV[8]	VOV[7]	VOV[6]	VOV[5]	VOV[4]
CFGR4	RD/WR	DCC0	MCAL	DCC6	DCC5	DCC4	DCC3	DCC2	DCC1
CFGR5	RD/WR	DCTO[3]	DCTO[2]	DCTO[1]	DCTO[0]	SCONV	FDRF	DIS_RED	DTMEN

Table 43. Cell Voltage Register Group A

REGISTER	RD/WR	BIT 7	BIT 6	BIT 5	BIT 4	BIT 3	BIT 2	BIT 1	BIT 0
CVAR0	RD	C1V[7]	C1V[6]	C1V[5]	C1V[4]	C1V[3]	C1V[2]	C1V[1]	C1V[0]
CVAR1	RD	C1V[15]	C1V[14]	C1V[13]	C1V[12]	C1V[11]	C1V[10]	C1V[9]	C1V[8]
CVAR2	RD	C2V[7]	C2V[6]	C2V[5]	C2V[4]	C2V[3]	C2V[2]	C2V[1]	C2V[0]
CVAR3	RD	C2V[15]	C2V[14]	C2V[13]	C2V[12]	C2V[11]	C2V[10]	C2V[9]	C2V[8]
CVAR4	RD	C3V[7]	C3V[6]	C3V[5]	C3V[4]	C3V[3]	C3V[2]	C3V[1]	C3V[0]
CVAR5	RD	C3V[15]	C3V[14]	C3V[13]	C3V[12]	C3V[11]	C3V[10]	C3V[9]	C3V[8]

Table 44. Cell Voltage Register Group B

REGISTER	RD/WR	BIT 7	BIT 6	BIT 5	BIT 4	BIT 3	BIT 2	BIT 1	BIT 0
CVBR0	RD	C4V[7]	C4V[6]	C4V[5]	C4V[4]	C4V[3]	C4V[2]	C4V[1]	C4V[0]
CVBR1	RD	C4V[15]	C4V[14]	C4V[13]	C4V[12]	C4V[11]	C4V[10]	C4V[9]	C4V[8]
CVBR2	RD	C5V[7]	C5V[6]	C5V[5]	C5V[4]	C5V[3]	C5V[2]	C5V[1]	C5V[0]
CVBR3	RD	C5V[15]	C5V[14]	C5V[13]	C5V[12]	C5V[11]	C5V[10]	C5V[9]	C5V[8]
CVBR4	RD	C6V[7]	C6V[6]	C6V[5]	C6V[4]	C6V[3]	C6V[2]	C6V[1]	C6V[0]
CVBR5	RD	C6V[15]	C6V[14]	C6V[13]	C6V[12]	C6V[11]	C6V[10]	C6V[9]	C6V[8]

Table 45. Auxiliary Register Group A

REGISTER	RD/WR	BIT 7	BIT 6	BIT 5	BIT 4	BIT 3	BIT 2	BIT 1	BIT 0
AVAR0	RD	S0V[7]	S0V[6]	S0V[5]	S0V[4]	S0V[3]	S0V[2]	S0V[1]	S0V[0]
AVAR1	RD	S0V[15]	S0V[14]	S0V[13]	S0V[12]	S0V[11]	S0V[10]	S0V[9]	S0V[8]
AVAR2	RD	G1V[7]	G1V[6]	G1V[5]	G1V[4]	G1V[3]	G1V[2]	G1V[1]	G1V[0]
AVAR3	RD	G1V[15]	G1V[14]	G1V[13]	G1V[12]	G1V[11]	G1V[10]	G1V[9]	G1V[8]
AVAR4	RD	G2V[7]	G2V[6]	G2V[5]	G2V[4]	G2V[3]	G2V[2]	G2V[1]	G2V[0]
AVAR5	RD	G2V[15]	G2V[14]	G2V[13]	G2V[12]	G2V[11]	G2V[10]	G2V[9]	G2V[8]

OPERATION

Table 46. Auxiliary Register Group B

REGISTER	RD/WR	BIT 7	BIT 6	BIT 5	BIT 4	BIT 3	BIT 2	BIT 1	BIT 0
AVBR0	RD	G3V[7]	G3V[6]	G3V[5]	G3V[4]	G3V[3]	G3V[2]	G3V[1]	G3V[0]
AVBR1	RD	G3V[15]	G3V[14]	G3V[13]	G3V[12]	G3V[11]	G3V[10]	G3V[9]	G3V[8]
AVBR2	RD	G4V[7]	G4V[6]	G4V[5]	G4V[4]	G4V[3]	G4V[2]	G4V[1]	G4V[0]
AVBR3	RD	G4V[15]	G4V[14]	G4V[13]	G4V[12]	G4V[11]	G4V[10]	G4V[9]	G4V[8]
AVBR4	RD	REF[7]	REF[6]	REF[5]	REF[4]	REF[3]	REF[2]	REF[1]	REF[0]
AVBR5	RD	REF[15]	REF[14]	REF[13]	REF[12]	REF[11]	REF[10]	REF[9]	REF[8]

Table 47. Status Register Group A

REGISTER	RD/WR	BIT 7	BIT 6	BIT 5	BIT 4	BIT 3	BIT 2	BIT 1	BIT 0
STAR0	RD	SC[7]	SC[6]	SC[5]	SC[4]	SC[3]	SC[2]	SC[1]	SC[0]
STAR1	RD	SC[15]	SC[14]	SC[13]	SC[12]	SC[11]	SC[10]	SC[9]	SC[8]
STAR2	RD	ITMP[7]	ITMP[6]	ITMP[5]	ITMP[4]	ITMP[3]	ITMP[2]	ITMP[1]	ITMP[0]
STAR3	RD	ITMP[15]	ITMP[14]	ITMP[13]	ITMP[12]	ITMP[11]	ITMP[10]	ITMP[9]	ITMP[8]
STAR4	RD	VA[7]	VA[6]	VA[5]	VA[4]	VA[3]	VA[2]	VA[1]	VA[0]
STAR5	RD	VA[15]	VA[14]	VA[13]	VA[12]	VA[11]	VA[10]	VA[9]	VA[8]

Table 48. Status Register Group B

REGISTER	RD/WR	BIT 7	BIT 6	BIT 5	BIT 4	BIT 3	BIT 2	BIT 1	BIT 0
STBR0	RD	VD[7]	VD[6]	VD[5]	VD[4]	VD[3]	VD[2]	VD[1]	VD[0]
STBR1	RD	VD[15]	VD[14]	VD[13]	VD[12]	VD[11]	VD[10]	VD[9]	VD[8]
STBR2	RD	C40V	C4UV	C30V	C3UV	C20V	C2UV	C10V	C1UV
STBR3	RD	RSVD	RSVD	RSVD	MUTE	C60V	C6UV	C50V	C5UV
STBR4	RD	RSVD	RSVD	RSVD	RSVD	RSVD	RSVD	RSVD	RSVD
STBR5	RD	REV[3]	REV[2]	REV[1]	REV[0]	RSVD	RSVD	MUXFAIL	THSD

Table 49. Redundant S Voltage Register Group A

REGISTER	RD/WR	BIT 7	BIT 6	BIT 5	BIT 4	BIT 3	BIT 2	BIT 1	BIT 0
CVCR0	RD	S1V[7]	S1V[6]	S1V[5]	S1V[4]	S1V[3]	S1V[2]	S1V[1]	S1V[0]
CVCR1	RD	S1V[15]	S1V[14]	S1V[13]	S1V[12]	S1V[11]	S1V[10]	S1V[9]	S1V[8]
CVCR2	RD	S2V[7]	S2V[6]	S2V[5]	S2V[4]	S2V[3]	S2V[2]	S2V[1]	S2V[0]
CVCR3	RD	S2V[15]	S2V[14]	S2V[13]	S2V[12]	S2V[11]	S2V[10]	S2V[9]	S2V[8]
CVCR4	RD	S3V[7]	S3V[6]	S3V[5]	S3V[4]	S3V[3]	S3V[2]	S3V[1]	S3V[0]
CVCR5	RD	S3V[15]	S3V[14]	S3V[13]	S3V[12]	S3V[11]	S3V[10]	S3V[9]	S3V[8]

OPERATION

Table 50. Redundant S Voltage Register Group B

REGISTER	RD/WR	BIT 7	BIT 6	BIT 5	BIT 4	BIT 3	BIT 2	BIT 1	BIT 0
CVDR0	RD	S4V[7]	S4V[6]	S4V[5]	S4V[4]	S4V[3]	S4V[2]	S4V[1]	S4V[0]
CVDR1	RD	S4V[15]	S4V[14]	S4V[13]	S4V[12]	S4V[11]	S4V[10]	S4V[9]	S4V[8]
CVDR2	RD	S5V[7]	S5V[6]	S5V[5]	S5V[4]	S5V[3]	S5V[2]	S5V[1]	S5V[0]
CVDR3	RD	S5V[15]	S5V[14]	S5V[13]	S5V[12]	S5V[11]	S5V[10]	S5V[9]	S5V[8]
CVDR4	RD	S6V[7]	S6V[6]	S6V[5]	S6V[4]	S6V[3]	S6V[2]	S6V[1]	S6V[0]
CVDR5	RD	S6V[15]	S6V[14]	S6V[13]	S6V[12]	S6V[11]	S6V[10]	S6V[9]	S6V[8]

Table 51. COMM Register Group

REGISTER	RD/WR	BIT 7	BIT 6	BIT 5	BIT 4	BIT 3	BIT 2	BIT 1	BIT 0
COMM0	RD/WR	ICOM0[3]	ICOM0[2]	ICOM0[1]	ICOM0[0]	D0[7]	D0[6]	D0[5]	D0[4]
COMM1	RD/WR	D0[3]	D0[2]	D0[1]	D0[0]	FCOM0[3]	FCOM0[2]	FCOM0[1]	FCOM0[0]
COMM2	RD/WR	ICOM1[3]	ICOM1[2]	ICOM1[1]	ICOM1[0]	D1[7]	D1[6]	D1[5]	D1[4]
COMM3	RD/WR	D1[3]	D1[2]	D1[1]	D1[0]	FCOM1[3]	FCOM1[2]	FCOM1[1]	FCOM1[0]
COMM4	RD/WR	ICOM2[3]	ICOM2[2]	ICOM2[1]	ICOM2[0]	D2[7]	D2[6]	D2[5]	D2[4]
COMM5	RD/WR	D2[3]	D2[2]	D2[1]	D2[0]	FCOM2[3]	FCOM2[2]	FCOM2[1]	FCOM2[0]

Table 52. PWM Register Group

REGISTER	RD/WR	BIT 7	BIT 6	BIT 5	BIT 4	BIT 3	BIT 2	BIT 1	BIT 0
SCTL0	RD/WR	PWM2[3]	PWM2[2]	PWM2[1]	PWM2[0]	PWM1[3]	PWM1[2]	PWM1[1]	PWM1[0]
SCTL1	RD/WR	PWM4[3]	PWM4[2]	PWM4[1]	PWM4[0]	PWM3[3]	PWM3[2]	PWM3[1]	PWM3[0]
SCTL2	RD/WR	PWM6[3]	PWM6[2]	PWM6[1]	PWM6[0]	PWM5[3]	PWM5[2]	PWM5[1]	PWM5[0]
SCTL3	RD/WR	RSVD	RSVD	RSVD	RSVD	RSVD	RSVD	RSVD	RSVD
SCTL4	RD/WR	RSVD	RSVD	RSVD	RSVD	RSVD	RSVD	RSVD	RSVD
SCTL5	RD/WR	RSVD	RSVD	RSVD	RSVD	RSVD	RSVD	RSVD	RSVD

Table 53. Serial ID Register Group

REGISTER	RD/WR	BIT 7	BIT 6	BIT 5	BIT 4	BIT 3	BIT 2	BIT 1	BIT 0
SIDR0	RD	SID[7]	SID[6]	SID[5]	SID[4]	SID[3]	SID[2]	SID[1]	SID[0]
SIDR1	RD	SID[15]	SID[14]	SID[13]	SID[12]	SID[11]	SID[10]	SID[9]	SID[8]
SIDR2	RD	SID[23]	SID[22]	SID[21]	SID[20]	SID[19]	SID[18]	SID[17]	SID[16]
SIDR3	RD	SID[31]	SID[30]	SID[29]	SID[28]	SID[27]	SID[26]	SID[25]	SID[24]
SIDR4	RD	SID[39]	SID[38]	SID[37]	SID[36]	SID[35]	SID[34]	SID[33]	SID[32]
SIDR5	RD	SID[47]	SID[46]	SID[45]	SID[44]	SID[43]	SID[42]	SID[41]	SID[40]

OPERATION

Table 54. Memory Bit Descriptions

NAME	DESCRIPTION	VALUES																
GPIOx	GPIOx Pin Control	Write: 0 -> GPIOx pin pull down ON; 1-> GPIOx pin pull down OFF Read: 0 -> GPIOx pin at logic 0; 1 -> GPIOx pin at logic 1																
REFON	References Powered Up	1 -> References remain powered up until watchdog time out 0 -> References shut down after conversions																
DTEN	Discharge Timer Enable	1 -> Enables the Discharge Timer for discharge switches 0 -> Disables Discharge Timer																
ADCOPT	ADC Mode Option Bit	ADCOPT: 0 -> Selects Modes 27kHz, 7kHz, 422Hz or 26Hz with MD[1:0] bits in ADC conversion commands. 1 -> Selects Modes 14kHz, 3kHz, 1kHz or 2kHz with MD[1:0] bits in ADC conversion commands.																
VUV	Undervoltage Comparison Voltage*	Comparison voltage = VUV • 16 • 100μV Default: VUV = 0x000																
VOV	Overvoltage Comparison Voltage*	Comparison voltage = VOV • 16 • 100μV Default: VUV = 0x000																
MCAL	Enables Multi-Calibration	1 -> Enables multicalibration during ADC conversions, for backwards compatibility with 6811/6812/6810. Defaults to 0, single calibration during ADC.																
DCC[x]	Discharge Cell x	x = 1 to 6 1 -> Turn ON shorting switch for Cell x, S[x] to S[x-1] 0 -> Turn OFF shorting switch for Cell x, S[x] to S[x-1] (default) x = 0 1 -> Turn ON S0 pulldown for discharging optional 7th cell 0 -> Turn OFF S0 pulldown (default)																
DCTO	Discharge Time Out Value	DCTO (Write)	0	1	2	3	4	5	6	7	8	9	A	B	C	D	E	F
		Time (min)	Disabled	0.5	1	2	3	4	5	10	15	20	30	40	60	75	90	120
		DCTO (Write)	0	1	2	3	4	5	6	7	8	9	A	B	C	D	E	F
		Time Left or Time (min)	Disabled or Time Out	0 to 0.5	0.5 to 1	1 to 2	2 to 3	3 to 4	4 to 5	5 to 10	10 to 15	15 to 20	20 to 30	30 to 40	40 to 60	60 to 75	75 to 90	90 to 120
SCONV	Enable Cell Measurement Redundancy Using S Pins	1 -> Enables redundant measurements of the cell voltages using the S pins 0 -> Disables redundant measurements of the cell voltages																
FDRF	Force Digital Redundancy Failure	1 -> Forces the digital redundancy comparison for A/D conversions to fail 0 -> Enables the normal redundancy comparison																
DIS_RED	Disable Digital Redundancy Check	1 -> Disables the digital redundancy comparison for A/D conversions 0 -> Enables the digital redundancy comparison for A/D conversions																
DTMEN	Enable Discharge Timer Monitor	1 -> Enables the Discharge Timer Monitor function if the DTEN pin is asserted. 0 -> Disables the Discharge Timer Monitor function. The normal Discharge Timer function will be enabled if DTEN pin is asserted.																
CxV	Cell x Voltage*	x = 1 to 6 16 bit ADC measurement value for Cell x Cell Voltage for Cell x = CxV • 100μV CxV is reset to 0xFFFF on power up and after Clear command																
S0V	S0 Voltage*	16 bit ADC measurement value for S0 with respect to V ⁻ S0 Voltage = S0V • 100μV S0V is reset to 0xFFFF on power up and after Clear command																

LTC6810-1/LTC6810-2

OPERATION

NAME	DESCRIPTION	VALUES					
GxV	GPIO x Voltage*	x = 1 to 4 16 bit ADC measurement value for GPIOx Voltage for GPIOx = GxV • 100µV GxV is reset to 0xFFFF on power up and after Clear command					
REF	2nd Reference Voltage*	16 bit ADC measurement value for 2nd Reference Voltage for 2nd Reference = REF • 100µV Normal range is within 2.99V to 3.01V considering data sheet limits, hysteresis and long term drift					
SC	Sum of All Cells Measurement*	16 bit ADC measurement value of the Sum of All Cell Voltages Sum of All Cells Voltage = SC • 100µV • 10					
ITMP	Internal Die Temperature*	16 bit ADC measurement value of Internal Die temperature Temperature measurement (°C) = ITMP • 100µV/7.5mV/°C – 273°C					
VA	Analog Power Supply Voltage*	16 bit ADC measurement value of Analog power supply voltage Analog Power supply voltage = VA • 100µV The value of VA is set by external components and should be in the range 4.5V to 5.5V for normal operation					
VD	Digital Power Supply Voltage*	16 bit ADC measurement value of Digital power supply voltage Digital Power supply voltage = VD • 100µV Normal range is within 2.7V to 3.6V					
CxOV	Cell 'x' Overvoltage Flag	x = 1 to 6 Cell voltage compared to VOV comparison voltage 0 -> Cell 'x' not flagged for overvoltage condition. 1 -> Cell 'x' flagged					
CxUV	Cell 'x' Undervoltage Flag	x = 1 to 6 Cell voltage compared to VUV comparison voltage 0 -> Cell 'x' not flagged for under-v					
REV	Revision Code	Device Revision Code					
RSVD	Reserved Bits	Read: Read back value can be 1 or 0					
RSVD0	Reserved Bits	Read: Read back value is always 0					
RSVD1	Reserved Bits	Read: Read back value is always 1					
MUXFAIL	Multiplexer Self Test Result	Read: 0 -> Multiplexer passed self test 1 -> Multiplexer failed self test					
THSD	Thermal Shutdown Status	Read: 0 -> Thermal shutdown has not occurred 1 -> Thermal shutdown has occurred THSD bit cleared to '0' on read of Status Register Group B					
SxV	Redundant Cell x Voltage* via the S pins	x = 1 to 6 16 bit redundant ADC measurement value for Cell x Redundant measurement of Cell Voltage for Cell x = SxV • 100µV SxV is reset to 0xFFFF on power up and after Clear command					
PWMx[x]	PWM Discharge Control	0000 – Selects 0% Discharge Duty Cycle if Watchdog Timer Has Expired 0001 – Selects 3.3% Discharge Duty Cycle if Watchdog Timer Has Expired 0010 – Selects 6.7% Discharge Duty Cycle if Watchdog Timer Has Expired ... 1110 – Selects 46.7% Discharge Duty Cycle if Watchdog Timer Has Expired 1111 – Selects 50% Discharge Duty Cycle if Watchdog Timer Has Expired					
SID[x]	Serial ID	Unique 48-bit serial identification code					
ICOMn	Initial Communication Control Bits	Write	I ² C	0110	0001	0000	0111
				START	STOP	BLANK	NO TRANSMIT
		Read	I ² C	1000	1010	1001	1111
				CSB low	CSB Falling Edge	CSB high	NO TRANSMIT
		SPI	I ² C	0110	0001	0000	0111
				START from Master	STOP from Master	SDA low between bytes	SDA high between bytes
SPI	0111						

OPERATION

NAME	DESCRIPTION	VALUES						
Dn	I ² C/SPI Communication Data Byte	Data transmitted(received) to(from) I ² C/SPI slave device						
FCOMn	Final Communication Control Bits	Write	I2C	0000		1000		1001
				Master ACK		Master NACK		Master NACK + STOP
			SPI	X000			1001	
		CSB low			CSB high			
		Read	I2C	0001	0111	1111	0001	1001
				ACK from Master	ACK from Slave	NACK from Slave	ACK from Slave + STOP from Master	NACK from Slave + STOP from Master
SPI	1111							

*Voltage equations use the decimal value of registers, 0 to 4095 for 12 bits and 0 to 65535 for 16 bits.

APPLICATIONS INFORMATION

PROVIDING DC POWER

The primary supply pin for the LTC6810 is the $5V \pm 0.5V$ V_{REG} input pin. There are three ways to generate the V_{REG} input as follows:

1. Simple Linear Regulator

The DRIVE pin can be used to form a discrete regulator with the addition of a few external components, as shown in Figure 36. The DRIVE pin provides a 5.6V output, capable of sourcing 1mA. When buffered with an NPN transistor, this provides a stable 5V over temperature. The NPN transistor should be chosen to have a sufficient Beta over temperature (>40) to supply the necessary supply current. The peak V_{REG} current requirement of the LTC6810 approaches 20mA when simultaneously communicating over isoSPI and making ADC conversions. If the V_{REG} pin is required to support any additional load, a transistor with an even higher beta may be required.

The NPN collector can be powered from any voltage source that is a minimum 6V above V_- . This includes the cells that are being monitored, or an unregulated power supply. A $100\Omega/100nF$ RC decoupling network is recommended for the collector power connection to protect the NPN from transients. The emitter of the NPN should be bypassed with a $1\mu F$ capacitor. Larger capacitance should be avoided since this will increase the wake-up time of the LTC6810. Some attention should be given to the thermal characteristic of the NPN, as there can be significant heating with a high collector voltage.

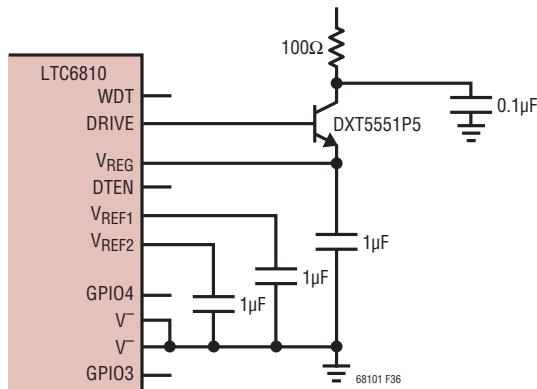

Figure 36. Simple V_{REG} Power Source Using NPN Pass Transistor

2. Internal Regulator

At low V^+ voltages where there is not enough headroom to regulate the Drive Pin, V_{REGA} is driven by an internal regulator. The Drive pin is designed such that when used with an external NPN, V_{REGA} will be set to a voltage that is at least 400mV greater than the internal V_{REGA} voltage. This ensures that when the DRIVE pin regulator has sufficient headroom the internal V_{REGA} will turn off. The internal regulator is enabled by applying a $25\mu A$ load on the DRIVE pin. Connecting a $100k$ resistor on the DRIVE pin to GND allows the part to work across the entire V^+ supply range. When V^+ is too low, the $100k$ resistor on the DRIVE pin pulls enough current to enable the internal regulator that sets V_{REGA} to about 4.7V. When V^+ is high, the DRIVE pin sets V_{REGA} to about 5.1V. The internal regulator is not capable of sinking current and will shutdown in this case.

3. External Regulator for Improved Efficiency

For improved efficiency when powering the LTC6810 from the cell stack, the V_{REG} may be powered from a DC/DC converter, rather than the NPN pass transistor. An ideal circuit is based on Analog Devices' LTC3990 step-down regulator, as shown in Figure 37. A 50Ω resistor is recommended between the battery stack and the LTC3990 input; this will prevent in-rush current when connecting to the stack and it will reduce conducted EMI. The EN pin should be connected to the DRIVE pin which will put the LTC3990 into a low power state when the LTC6810 is in the sleep state. In this mode, to avoid any contention with the internally generated V_{REGA} , the load current on the DRIVE pin should be less than $1\mu A$ to ensure that the internal regulator is disabled.

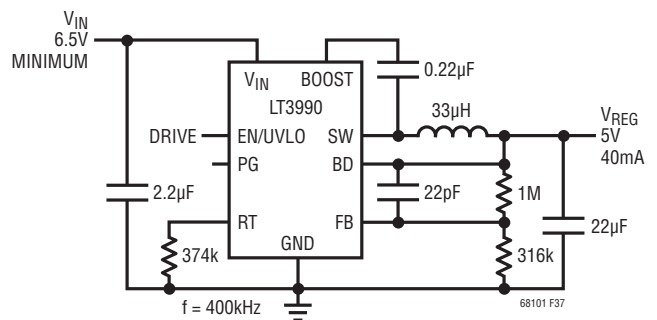

Figure 37. V_{REG} Powered from Cell Stack with High Efficiency Regulator

APPLICATIONS INFORMATION

INTERNAL PROTECTION AND FILTERING

Internal Protection Features

The LTC6810 incorporates various ESD safeguards to ensure robust performance. An equivalent circuit showing the specific protection structures is shown in Figure 38. While pins 34 to 39 have different functionality for the LTC6810-1 and LTC6810-2 variants, the protection

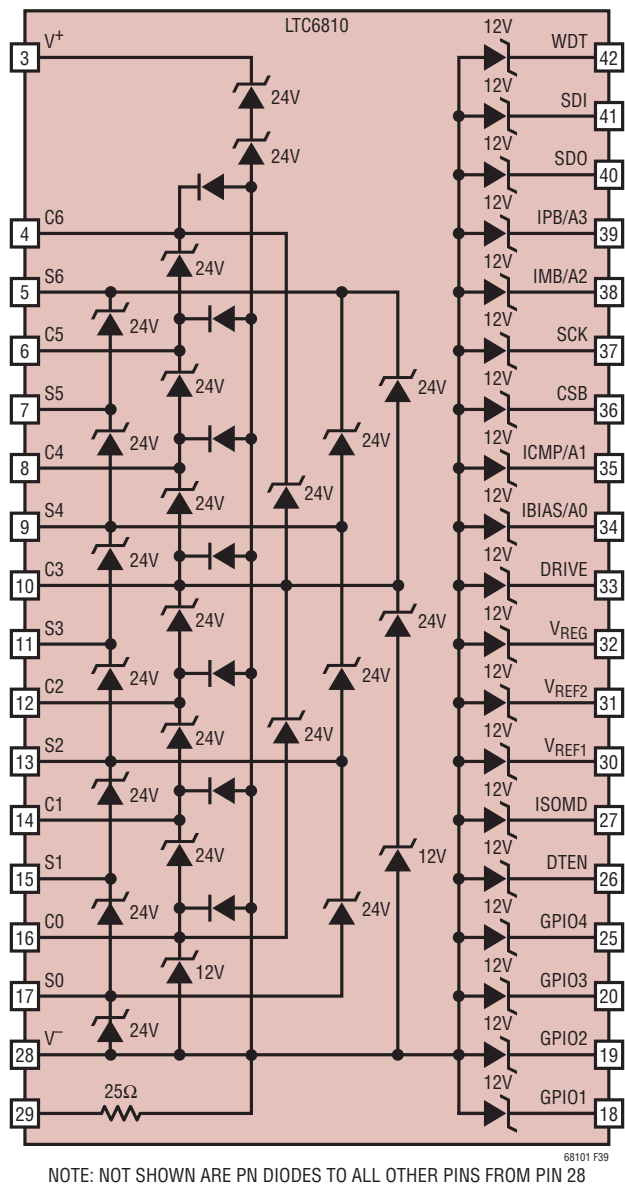

Figure 38. Internal ESD Protection Structures of the LTC6810

structure is the same. Zener-like suppressors are shown with their nominal clamp voltage, and the unmarked diodes exhibit standard PN junction behavior.

Filtering of Cell and GPIO Inputs

The LTC6810 uses a delta-sigma ADC, which has a delta sigma modulator followed by a SINC3 finite impulse response (FIR) digital filter. This greatly relaxes input filtering requirements. Furthermore, the programmable oversampling ratio allows the user to determine the best trade-off between measurement speed and filter cutoff frequency. Even with this high order low pass filter, fast transient noise can still induce some residual noise in measurements, especially in the faster conversion modes. This can be minimized by adding an RC low pass decoupling to each ADC input, which also helps reject potentially damaging high energy transients. Adding more than about 100Ω to the ADC inputs begins to introduce a systematic error in the measurement, which can be improved by raising the filter capacitance or mathematically compensating in software with a calibration procedure. For situations that demand the highest level of battery voltage ripple rejection, grounded capacitor filtering is recommended. This configuration has a series resistance and capacitors that decouple HF noise to V-. In systems where noise is less periodic or higher oversample rates are in use, a differential capacitor filter structure is adequate. In this configuration there are series resistors to each input, but the capacitors connect between the adjacent C pins. However, the differential capacitor sections interact. As a result, the filter response is less consistent and results in less attenuation than predicted by the RC, by approximately a decade. Note that the capacitors only see one cell of applied voltage (thus smaller and lower cost) and tend to distribute transient energy uniformly across the IC (reducing stress events on the internal protection structure). Figure 39 shows the two methods schematically. ADC accuracy varies with R, C as shown in the Typical Performance curves, but error is minimized if R = 100Ω and C = 10nF. The GPIO pins will always use a grounded capacitor configuration because the measurements are all with respect to V-.

APPLICATIONS INFORMATION

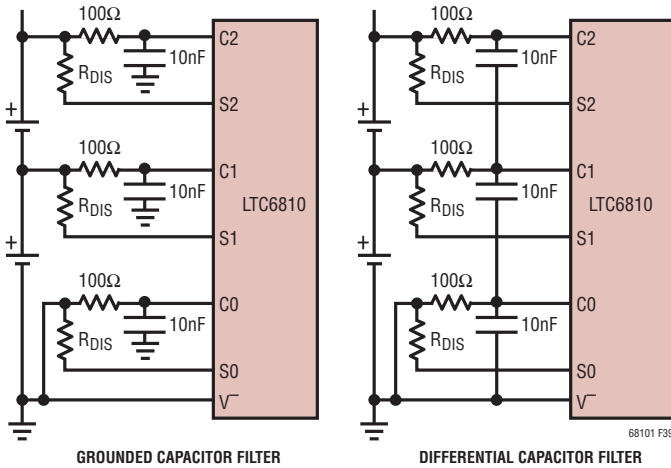

Figure 39. Input Filter Structure Configurations

CELL BALANCING

The LTC6810 includes signals (pins S0 through S6) that can be used to balance cells with internal or external discharge. Cells can be discharged using the internal N-channel NMOS at the S pins, or the S pins can act as digital outputs to drive external transistors. Figure 40 shows an example of internal cell balancing using the LTC6810.

Choosing a Discharge Resistor

When sizing the balancing resistor it is important to know the typical battery imbalance and the allowable time for cell balancing. In most small battery applications it is reasonable for the balancing circuitry to be able to correct for a 5% SOC (State Of Charge) error with 5 hours of balancing. For example a 5Ahr battery with a 5% SOC imbalance will have approximately 250mAHrs of imbalance. Using a 50mA balancing current this could be corrected in 5 hours. With a 100mA balancing current, the error would be corrected in 2.5Hrs. In systems with very large batteries it becomes difficult to use passive balancing to correct large SOC imbalances in short periods of time. The excessive heat created during balancing generally limits the balancing current. In large capacity battery

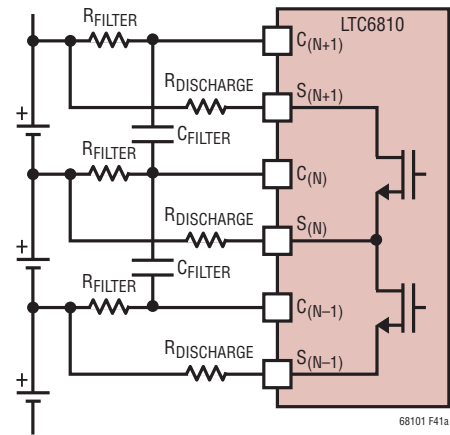

a)

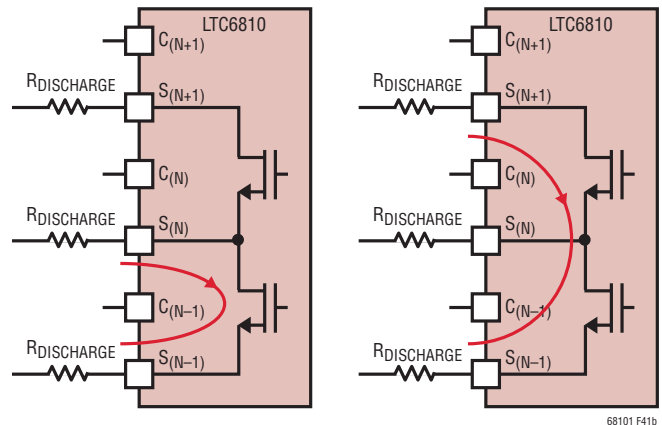

b)

Figure 40. Internal Discharge Circuits

applications if short balancing times are required an active balancing solution should be considered. When choosing a balance resistor the following equations can be used to help determine a resistor value:

$$\text{Balance Current} = \frac{\%SOC_Imbalance \cdot \text{Battery Capacity}}{\text{Number of Hours to Balance}}$$

$$\text{Balance Resistor} = \frac{\text{Nominal Cell Voltage}}{\text{Balance Current}}$$

APPLICATIONS INFORMATION

With passive balancing, if one cell in a series stack becomes overcharged, an S output can slowly discharge this cell by connecting it to a resistor. Each S output is connected to an internal N-channel MOSFET with a maximum on resistance of 4Ω . An external resistor should be connected in series with these MOSFETs to allow most of the heat to be dissipated outside of the LTC6810 package, as illustrated in Figure 40.

Cell Balancing with Internal MOSFETs

The internal discharge switches (MOSFETs) S1 through S6 can be used to passively balance cells as shown in Figure 40a with balancing current of 150mA or less. Balancing current larger than 150mA is not recommended for the internal switches due to excessive die heating. When discharging cells with the internal discharge switches, the die temperature should be monitored.

Figure 40b shows the discharge current path thru the internal discharge switches. Asserting adjacent discharge switches will result in a current path shown on the right in Figure 40b. The LTC6810 does not allow adjacent discharge switches to be asserted, so the WRFG command will not be executed if adjacent DCC bits in the CONFIG register are asserted. The current path shown at the right of Figure 40b shows that if adjacent discharge switches were permitted to be on, discharge current would flow through the series combination of cells instead of the individual cells.

Cell Balancing with External Transistors

For applications that require balancing currents above 150mA, the S outputs can be used to control external transistors. The S pins can act as digital outputs suitable for driving the gate of an external MOSFET or the base of an external NPN as illustrated in Figure 41. Figure 41 shows external transistor circuits that include RC filtering.

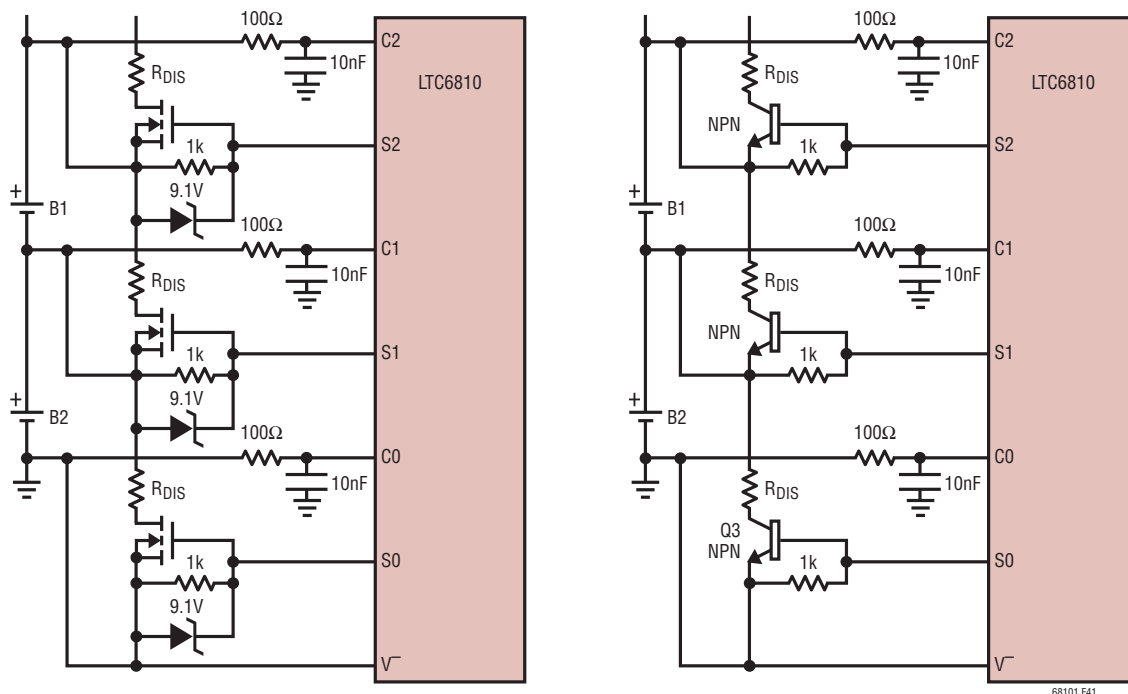

Figure 41. External Discharge Circuit

APPLICATIONS INFORMATION

Table 55. Discharge Control During an ADCV Command with DCP = 0

DISCHARGE PIN	CELL MEASUREMENT PERIODS						CELL CALIBRATION PERIODS					
	CELL1	CELL2	CELL3	CELL4	CELL5	CELL6	CELL1	CELL2	CELL3	CELL4	CELL5	CELL6
	t_0 to t_{1M}	t_{1M} to t_{2M}	t_{2M} to t_{3M}	t_{3M} to t_{4M}	t_{4M} to t_{5M}	t_{5M} to t_{6M}	t_{6M} to t_{1C}	t_{1C} to t_{2C}	t_{2C} to t_{3C}	t_{3C} to t_{4C}	t_{4C} to t_{5C}	t_{5C} to t_{6C}
S1	OFF	OFF	ON	ON	ON	OFF	OFF	OFF	ON	ON	ON	OFF
S2	OFF	OFF	OFF	ON	ON	ON	OFF	OFF	OFF	ON	ON	ON
S3	ON	OFF	OFF	OFF	ON	ON	ON	OFF	OFF	OFF	ON	ON
S4	ON	ON	OFF	OFF	OFF	ON	ON	ON	OFF	OFF	OFF	ON
S5	ON	ON	ON	OFF	OFF	OFF	ON	ON	ON	OFF	OFF	OFF
S6	OFF	ON	ON	ON	OFF	OFF	OFF	ON	ON	ON	OFF	OFF

DISCHARGE CONTROL DURING CELL MEASUREMENTS

If the discharge permitted (DCP) bit is high at the time of a cell measurement command, the S pin discharge states do not change during cell measurements. However, if the DCP bit is low, S pin discharge states will be disabled while the corresponding cell or adjacent cells are being measured. If using an external discharge transistor, the relatively low 1k Ω impedance of the internal LTC6810 PMOS transistors should allow the discharge currents to fully turn off before the cell measurement. Table 55 illustrates the ADCV command with DCP = 0. In this table, OFF indicates that the S pin discharge is forced off irrespective of the state of the corresponding DCC[x] bit. ON indicates that the S pin discharge will remain on during the measurement period if it was ON prior to the measurement command.

In some cases it is not possible for the automatic discharge control to eliminate all measurement error caused by running the discharges. This is due to the discharge transistor not turning off fast enough for the cell voltage to completely settle before the measurement starts. For the best measurement accuracy when running discharge, the MUTE and UNMUTE commands should be used. The MUTE command can be issued to temporarily disable all discharge transistors before the ADCV command is issued. After issuing a MUTE command a delay of roughly 50 μ S should be issued before sending a ADC conversion

command. This allows the cell voltage to settle before any measurement is taken. After the cell conversion completes an UNMUTE can be sent to re-enable all discharge transistors that were previously ON. Using this method maximizes the measurement accuracy with a very small time penalty.

Method to Verify Discharge Circuits

When using the internal and external discharge feature, the ability to verify the discharge functionality can be verified in software. The discharge circuits are shown in Figures 40 and 41. The functionality of the discharge circuits can be verified by implementing a redundant S pin measurement and comparing it to a C pin measurement. The S pins on the LTC6810 have two purposes, to provide internal discharge or turn on the external discharge device but also to allow for a redundant cell measurement. Asserting the SCONV bit in the config register will enable the redundant S pin cell measurements. The S pin measurements taken when the discharge is on require that the discharge permit bit (DCP) be set. The S pin measurements when discharge is on will be a function of the external discharge resistors but will generally be substantially less than C pin measurements. The resistance of the internal discharge FET is approximately 10 Ω , if the external discharge resistor in Figure 40 is also 10 Ω , the S pin measurement when discharge is on will be 1/3 of the C pin measurement.

APPLICATIONS INFORMATION

Seven Cell Application with Redundant Measurement

The LTC6810 has the ability to measure an additional seventh cell with redundancy and internal discharge capability. In six cell applications C0 is connected to V^- . An additional seventh cell, Cell 0, can be connected between C0 and V^- as shown in Figure 42. The primary cell measurement is done by connecting GPIO1 to C0 and using the ADAX command to measure Cell 0. External filtering

is added to the C0 pin as shown in Figure 42. A redundant measurement can be made by with the S0 pin. Asserting the SCONV bit in the configuration register and using the ADCVAX command will combine the six cell measurements with redundancy along with measurements of S0 and GPIO1. Figure 43 shows the seven cell application where the S pins are used to drive the gates of external MOSFETs. An external PFET is used to discharge Cell 0.

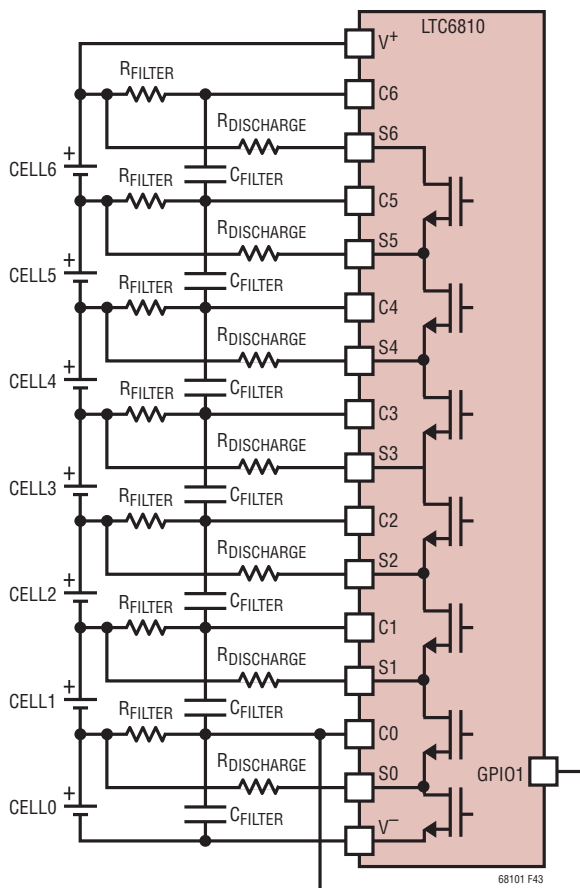

Figure 42. Seven Cell with Internal Discharge

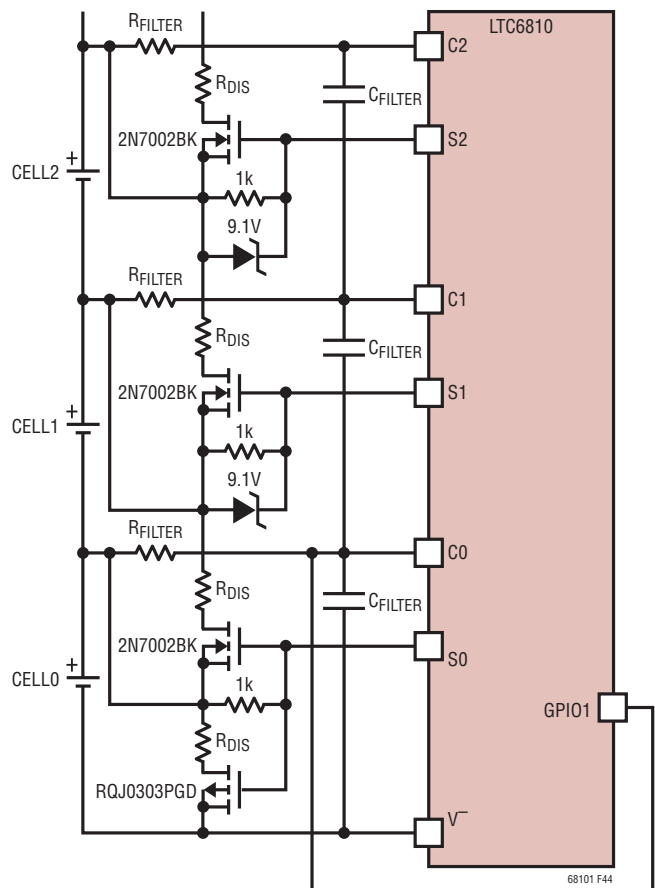

Figure 43. Seven Cell with External Discharge

APPLICATIONS INFORMATION

DIGITAL COMMUNICATIONS

PEC Calculation

The Packet Error Code (PEC) can be used to ensure that the serial data read from the LTC6810 is valid and has not been corrupted. This is a critical feature for reliable communication, particularly in environments of high noise. The LTC6810 requires that a PEC be calculated for all data being read from and written to the LTC6810. For this reason it is important to have an efficient method for calculating the PEC.

The C code below provides a simple implementation of a lookup table derived PEC calculation method. There are two functions. The first function `init_PEC15_Table()` should only be called once when the microcontroller starts and will initialize a PEC15 table array called `pec15Table[]`. This table will be used in all future PEC calculations. The PEC15 table can also be hard coded into the microcontroller rather than running the `init_PEC15_Table()` function at startup. The `pec15()` function calculates the PEC and will return the correct 15 bit PEC for byte arrays of any given length.

```

/*****
Copyright 2012 Analog Devices, Inc.
Permission to freely use, copy, modify, and distribute this software for any
purpose with or without fee is hereby granted, provided that the above
copyright notice and this permission notice appear in all copies:
THIS SOFTWARE IS PROVIDED "AS IS" AND LTC DISCLAIMS ALL WARRANTIES
INCLUDING ALL IMPLIED WARRANTIES OF MERCHANTABILITY AND FITNESS. IN NO
EVENT SHALL LTC BE LIABLE FOR ANY SPECIAL, DIRECT, INDIRECT, OR CONSEQUENTIAL
DAMAGES OR ANY DAMAGES WHATSOEVER RESULTING FROM ANY USE OF SAME, INCLUDING
ANY LOSS OF USE OR DATA OR PROFITS, WHETHER IN AN ACTION OF CONTRACT, NEGLIGENCE
OR OTHER TORTUOUS ACTION, ARISING OUT OF OR IN CONNECTION WITH THE USE OR
PERFORMANCE OF THIS SOFTWARE.
*****/
int16 pec15Table[256];
int16 CRC15_POLY = 0x4599;
void init_PEC15_Table()
{
    for (int i = 0; i < 256; i++)
    {
        remainder = i << 7;
        for (int bit = 8; bit > 0; --bit)
        {
            if (remainder & 0x4000)
            {
                remainder = ((remainder << 1));
                remainder = (remainder ^ CRC15_POLY)
            }
            else
            {
                remainder = ((remainder << 1));
            }
        }
        pec15Table[i] = remainder&0xFFFF;
    }
}
unsigned int16 pec15 (char *data , int len)
{
    int16 remainder,address;
    remainder = 16;//PEC seed
    for (int i = 0; i < len; i++)
    {
        address = ((remainder >> 7) ^ data[i]) & 0xff;//calculate PEC table address
        remainder = (remainder << 8 ) ^ pec15Table[address];
    }
    return (remainder*2);//The CRC15 has a 0 in the LSB so the final value must be multiplied by 2
}

```

APPLICATIONS INFORMATION

isoSPI IBIAS and ICMP Setup

The LTC6810 allows the isoSPI links of each application to be optimized for power consumption or for noise immunity. The power and noise immunity of an isoSPI system is determined by the programmed I_B current, which controls the isoSPI signaling currents. Bias current I_B can range from $100\mu\text{A}$ to 1mA . Internal circuitry scales up this bias current to create the isoSPI signal currents equal to be $20 \cdot I_B$. A low I_B reduces the isoSPI power consumption in the READY and ACTIVE states, while a high I_B increases the amplitude of the differential signal voltage V_A across the matching termination resistor, R_M . The I_B current is programmed by the sum of the R_{B1} and R_{B2} resistors connected between the 2V IBIAS pin and GND as shown in Figure 44. The receiver input threshold is set by the ICMP voltage that is programmed with the resistor divider created by the R_{B1} and R_{B2} resistors. The receiver differential threshold will be half of the voltage present on the ICMP pin.

The following guidelines should be used when setting the bias current ($100\mu\text{A}$ to 1mA) I_B and the receiver comparator threshold voltage $V_{ICMP}/2$:

R_M = Transmission Line Characteristic Impedance Z_0

Signal Amplitude $V_A = (20 \cdot I_B) \cdot (R_M/2)$

V_{TCMP} (Receiver Comparator Threshold) = $K \cdot V_A$

V_{ICMP} (Voltage on ICMP pin) = $2 \cdot V_{TCMP}$

$R_{B2} = V_{ICMP}/I_B = 20 \cdot K \cdot R_M$

$R_{B1} = (2/I_B) - R_{B2}$

Select I_B and K (Signal Amplitude V_A to Receiver input threshold ratio) according to the application:

For lower power links: $I_B = 0.5\text{mA}$ and $K = 0.5$

For full power links: $I_B = 1\text{mA}$ and $K = 0.5$

For long links (>50m): $I_B = 1\text{mA}$ and $K = 0.25$

For addressable multidrop: $I_B = 1\text{mA}$ and $K = 0.4$

For applications with little system noise, setting I_B to 0.5mA is a good compromise between power consumption and noise immunity. Using this I_B setting with a 1:1 transformer and $R_M = 100\Omega$, R_{B1} should be set to 3.01k and R_{B2} set to 1k . With typical CAT5 twisted pair, these settings will allow for communication up to 50m. Applications in very noisy environments or with cables longer than 50m should increase the I_B to 1mA . Higher drive current compensates for the increased insertion loss in the cable and provides high noise immunity. When using cables over 50m and a transformer with a 1:1 turns ratio and $R_M = 100\Omega$, R_{B1} would be 1.5k and R_{B2} would be 499Ω .

The length of the cable determines the maximum clock rate of an isoSPI link. For cables 10 meters or less, the maximum 1MHz SPI clock frequency is possible. As the length of the cable increases, the maximum possible SPI clock rate decreases. This dependence is a result of the increased propagation delays that can create possible timing violations. Figure 45 shows how the maximum data rate reduces as the cable length increases when using a CAT 5 twisted pair.

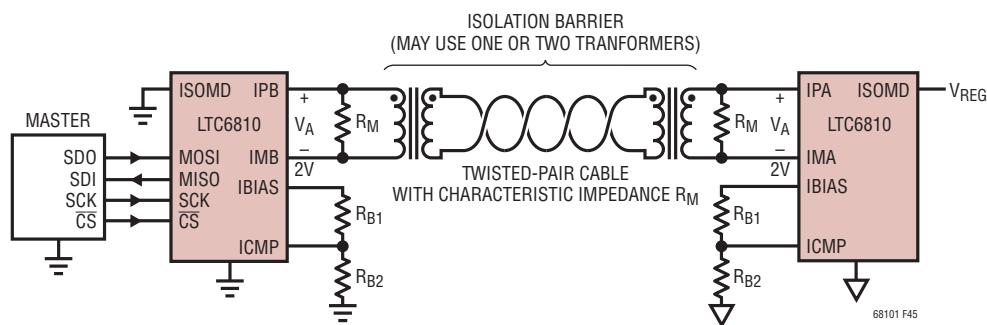

Figure 44. isoSPI Circuit

APPLICATIONS INFORMATION

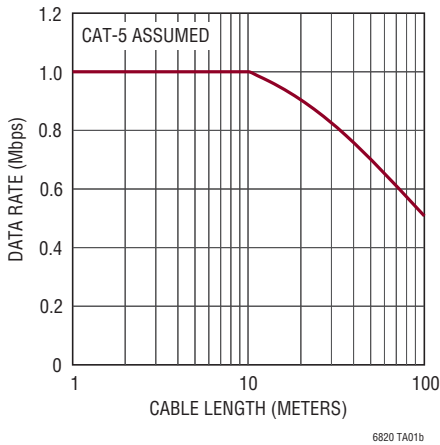

Figure 45. Data Rate vs Cable Length

Cable delay affects three timing specifications, t_{CLK} , t_6 and t_7 . In the Electrical Characteristics table, each is derated by 100ns to allow for 50ns of cable delay. For longer cables, the minimum timing parameters obey the following relationship:

$$t_{CLK}, t_6 \text{ and } t_7 > 0.9\mu s + 2 \cdot t_{CABLE}(0.2m \text{ per } nS)$$

Implementing a Modular isoSPI Daisy Chain

The hardware design of a daisy-chain isoSPI bus is identical for each device in the network due to the daisy-chain point-to-point architecture. The simple design as shown in Figure 44 is functional, but inadequate for most designs. The use of cables between battery modules, particularly in automotive applications, can add noise to the communication lines. Therefore, the termination resistor R_M should be split and bypassed with a capacitor as shown in Figure 46. This change provides both a differential and a common mode termination, which increases the system noise immunity.

For high levels of electromagnetic interference (EMC), additional filtering is recommended. The circuit example in Figure 46 shows the use of common-mode chokes (CMC) to add common-mode noise rejection from transients on the battery lines. The use of a center tapped transformer will also provide additional noise performance. A bypass capacitor connected to the center tap creates a low impedance for common-mode noise (Figure 46b). Since transformers without a center tap can be less expensive,

they may be preferred. In this case, the addition of a split termination resistor and a bypass capacitor (Figure 46a) can enhance the isoSPI performance. Large center tap capacitors greater than 10nF should be avoided as they may prevent the isoSPI common mode voltage from settling. Common mode chokes similar to those used in Ethernet or CANbus applications are recommended. Specific examples are provided in Table 57.

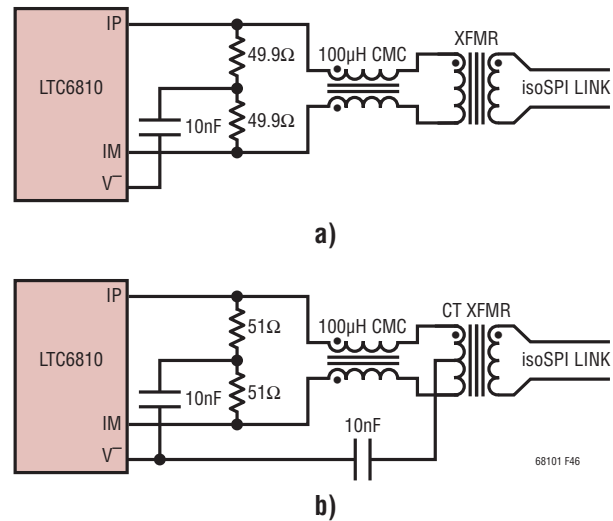

Figure 46. Daisy Chain Interface Components

An important daisy chain design consideration is the number of devices in the isoSPI network, since this determines the serial timing and affects data latency and throughput. The maximum number of devices in an isoSPI daisy chain is dictated by the serial timing requirements. However, it is important to note that the serial read back time, and the increased current consumption, might present a practical limitation.

For a daisy chain, there are two timing consideration that must be made (see Figure 29) to guarantee proper operation:

1. t_6 , the time between the last clock and the rising chip select must be long enough.
2. t_5 , the time between commands, so the time from a rising chip select to the next falling chip select must be long enough.

APPLICATIONS INFORMATION

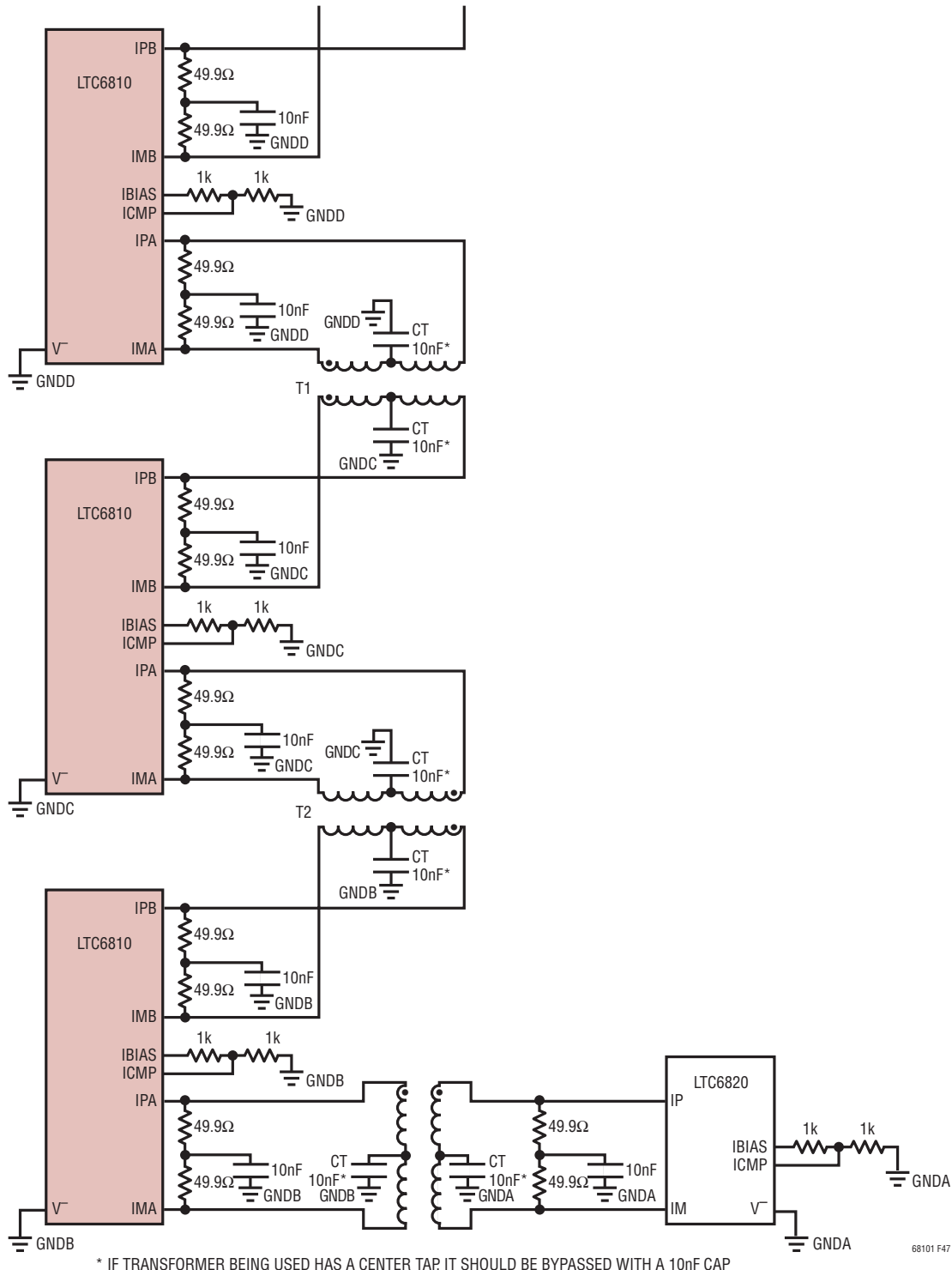

Figure 47. Daisy Chain Interface Components on Single Board

APPLICATIONS INFORMATION

Both t_5 and t_6 must be lengthened as the number of LTC6810 devices in the daisy chain increase. The equations for these times are below:

$$t_5 > (\# \text{devices} \cdot 70\text{ns}) + 900\text{ns}$$

$$t_6 > (\# \text{devices} \cdot 70\text{ns}) + 950\text{ns}$$

Connecting Multiple LTC6810-1s on the Same PCB

When connecting multiple LTC6810-1 devices on the same PCB, only a single transformer is required between the LTC6810-1 isoSPI ports. The absence of the cable also reduces the noise levels on the communication lines and often only a split termination is required. Figure 47 shows an example application that has multiple LTC6810-1s

on the same PCB, communicating to the bottom MCU through a LTC6820 isoSPI driver. If a transformer with a center tap is used, a capacitor can be added for better noise rejection. Additional noise filtering is provided with discrete common mode chokes (CMC) placed to both sides of the single transformer as shown in Figure 47.

On single board designs with lower noise requirements, it is possible for a simplified capacitor-isolated coupling as shown in Figure 48 to replace the transformer. In this circuit the transformer is directly replaced with two 10nF capacitors. An optional common mode choke (CMC) helps provides noise rejection similar to application circuits using transformers. The circuit is designed to use IBIAS/ICMP settings identical to the transformer circuit.

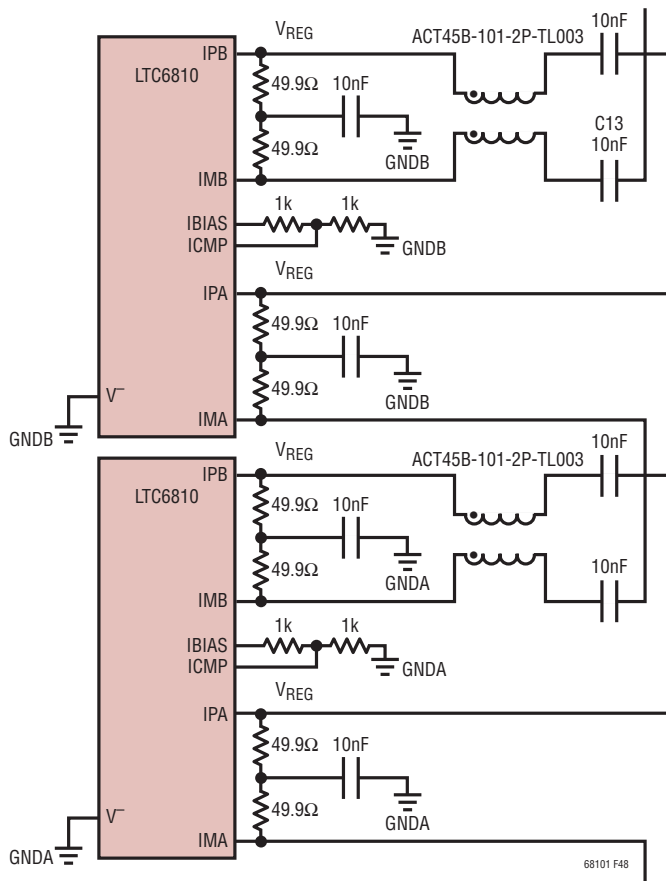

Figure 48. Capacitive Isolation Coupling for LTC6810-1s on the Same PCB

APPLICATIONS INFORMATION

Connecting an MCU to an LTC6810-1 with an isoSPI Data Link

The LTC6820 will convert standard 4-wire SPI into a 2-wire isoSPI link that can communicate directly with the LTC6810. An example is shown in Figure 49. The LTC6820 can be used in applications to easily provide isolation between the microcontroller and the stack of LTC6810s. The LTC6820 also enables system configurations that have the BMS controller at a remote location relative to the LTC6810 devices and the battery pack.

Configuring the LTC6810-2 in a Multi-Drop isoSPI Link

The addressing feature of the LTC6810-2 allows multiple devices to be connected to a single isoSPI master by distributing them along one twisted pair. In effect, this creates a large parallel SPI network. A basic multi-drop system is shown in Figure 50; the twisted pair is terminated only at the beginning (master) and the end of the cable. In between, the additional LTC6810-2s are connected to short stubs on the twisted pair. These stubs should be kept short, with as little capacitance as possible, to avoid degrading the termination along the isoSPI wiring.

When an LTC6810-2 is not addressed, it will not transmit data pulses. This eliminates the possibility for collisions

since only the addressed device returns data to the master. Generally, multi-drop systems are best confined to compact assemblies where they can avoid excessive isoSPI pulse-distortion and EMC pickup.

Basic Connection of the LTC6810-2 in a Multi-Drop Configuration

In a multi-drop isoSPI bus, placing the termination at the end of the transmission line provides the best performance (with 100Ω typically). Each of the LTC6810 isoSPI ports should be connected to the bus with a resistor network, as shown in Figure 51a. Here again, a center-tapped transformer offers the best performance and a common-mode-choke (CMC) increases the noise rejection further, as shown in Figure 51b. An RC snubber is used at the IC connections to suppress resonances (the IC capacitance provides sufficient out-of-band rejection). When using a non-center-tapped transformer, a virtual CT can be generated by connecting a CMC as a voltage-splitter. Series resistors are recommended to decouple the LTC6810 and board parasitic capacitance from the transmission line. Reducing these parasitics on the transmission line will minimize reflections.

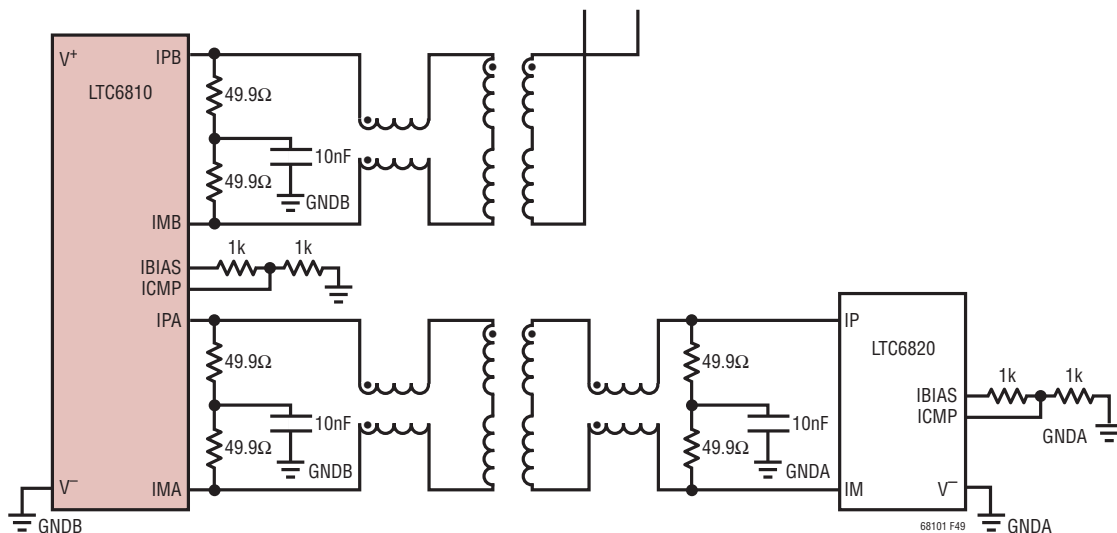

Figure 49. Interfacing an LTC6810-1 with a μ C Using an LTC6820 for Isolated SPI Control

APPLICATIONS INFORMATION

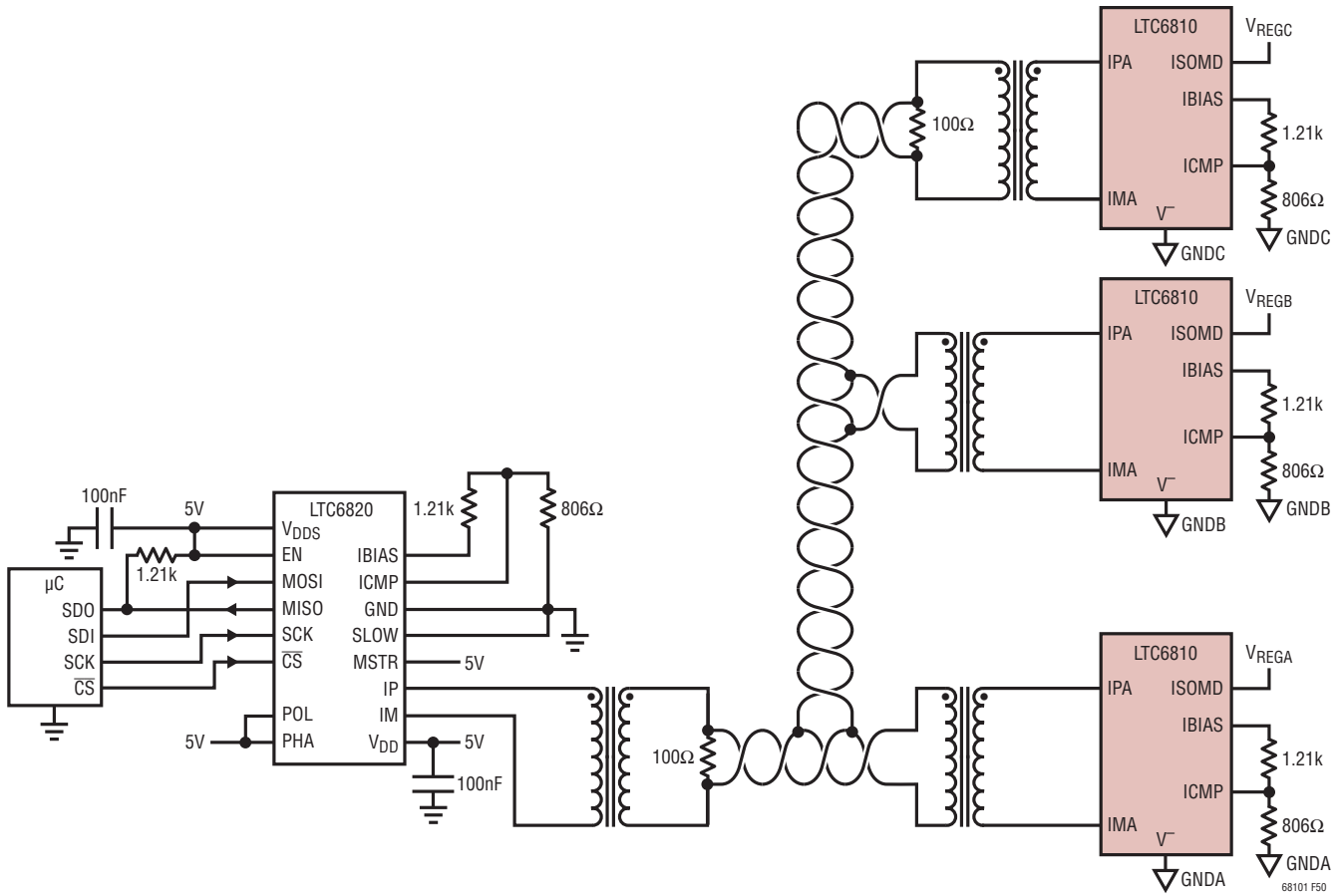

Figure 50. Connecting the LTC6810-2 in a Multi-Drop Configuration

APPLICATIONS INFORMATION

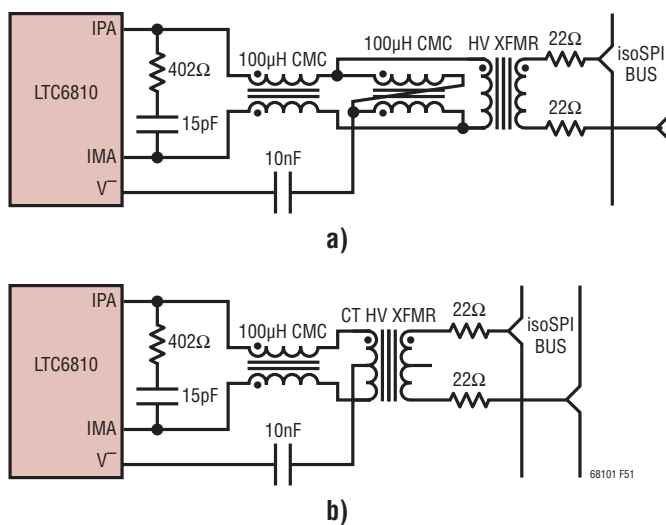

Figure 51. Preferred isoSPI Bus Couplings For Use With LTC6810-2

APPLICATIONS INFORMATION

Table 56. Recommended Transformers

SUPPLIER	PART NUMBER	TEMP RANGE	V _{WORKING}	V _{HIPOT/60S}	CT	CMC	H	L	W (W/ LEADS)	PINS	AEC- Q200
Recommended Dual Transformers											
Bourns	SM91501AL	-40°C to 125°C	1000V	4.3kVdc	●	●	5.0mm	15.0mm	14.7mm	12SMT	●
Bourns	SM13105L (AS4562)	-40°C to 125°C	1600V	4.3kVrms	●	●	5.0mm	15.0mm	27.9mm	12SMT	–
Bourns	US4374	-40°C to 125°C	950V	4.3kVdc	●	●	4.9mm	15.6mm	24.0mm	12SMT	●
Jingweida	S12502BA	-40°C to 125°C	1000V	4.3kVdc	●	●	5.0mm	14.8mm	14.8mm	12SMT	●
Halo	TG110-AE050N5LF	-40°C to 85/125°C	60V (est)	1.5kVrms	●	●	6.4mm	12.7mm	9.5mm	16SMT	●
Sumida	CLP178-C20114	-40°C to 125°C	1000V (est)	3.75kVrms	●	●	9mm	17.5mm	15.1mm	12SMT	–
Sumida	CLP0612-C20115		600Vrms	3.75kVrms	●	–	5.7mm	12.7mm	9.4mm	16SMT	–
Pulse	HM2100NL	-40°C to 105°C	1000V	4.3kVdc	–	●	3.5mm	14.7mm	15.0mm	10SMT	●
Pulse	HM2112ZNL	-40°C to 125°C	1600V	4.3kVdc	●	●	3.5mm	14.7mm	15.5mm	12SMT	●
Pulse	HX1188FNL	-40°C to 85°C	60V (est)	1.5kVrms	●	●	6.0mm	12.7mm	9.7mm	16SMT	–
Pulse	HX0068ANL	-40°C to 85°C	60V (est)	1.5kVrms	●	●	2.1mm	12.7mm	9.7mm	16SMT	–
Würth	7490140110	-40°C to 85°C	250Vrms	4kVrms	●	●	10.9mm	24.6mm	17.0mm	16SMT	–
Würth	7490140111	0°C to 70°C	1000V (est)	4.5kVrms	●	–	8.4mm	17.1mm	15.2mm	12SMT	–
Würth	749014018	0°C to 70°C	250Vrms	4kVrms	●	●	8.4mm	17.1mm	15.2mm	12SMT	–
Recommended Single Transformers											
Bourns	SM91502AL	-40°C to 125°C	1000V	4.3kVdc	●	●	6.5mm	8.5mm	8.9mm	6SMT	●
Bourns	SM13102AL (US4195)	-40°C to 125°C	800V	4kVrms	●	●	3.8mm	11.6mm	21.1mm	6SMT	–
Halo	TD04-QXLTAW	-40°C to 85°C	1000V (est)	5kVrms	●	–	8.6mm	8.9mm	16.6mm	6TH	–
Halo	TGR04-6506V6LF	-40°C to 125°C	300V	3kVrms	●	–	10mm	9.5mm	12.1mm	6SMT	–
Halo	TGR04-A6506NA6NL	-40°C to 125°C	300V	3kVrms	●	–	9.4mm	8.9mm	12.1mm	6SMT	●
Halo	TDR04-A550ALLF	-40°C to 105°C	1000V	5kVrms	●	–	6.4mm	8.9mm	16.6mm	6TH	●
Jingweida	S06107BA	-40°C to 125°C	1000V (est)	4.3kVdc	●	●	6.3mm	7.6mm	9.9mm	6SMT	–
Pulse	HM2101NL	-40°C to 105°C	1000V	4.3kVdc	–	●	5.7mm	7.6mm	9.3mm	6SMT	●
Pulse	HM2113ZNL	-40°C to 125°C	1600V	4.3kVdc	●	●	3.5mm	9mm	15.5mm	6SMT	●
Sumida	CEEH96BNP-LTC6804/11	-40°C to 125°C	600V	2.5kVrms	–	–	7mm	9.2mm	12.0mm	4SMT	–
Sumida	CEP99NP-LTC6804	-40°C to 125°C	600V	2.5kVrms	●	–	10mm	9.2mm	12.0mm	8SMT	–
Sumida	ESMIT-4180/A	-40°C to 105°C	250Vrms	3kVrms	–	–	3.5mm	5.2mm	9.1mm	4SMT	●
Sumida	ESMIT-4187	-40°C to 105°C	>400Vrms (est)	2.5kVrms	–	–	3.5mm	7.5mm	12.8mm	4SMT	●
TDK	VMT40DR-201S2P4	-40°C to 125°C	600V (est)	3.4kVdc	●	–	4.0mm	8.5mm	13.8mm	6SMT	●
TDK	ALT4532V-201-T001	-40°C to 105°C	80V	~1kV	●	–	2.9mm	3.2mm	4.5mm	6SMT	●
TDK	VGT10/9EE-204S2P4	-40°C to 125°C	700V	2.8kVrms	●	–	10.6mm	10.4mm	12.6mm	8SMT	●
Sunlord	ALTW0806C-C03	-40°C to 125°C	300V (est)	3kVrms	●	–	8.8mm	6.3mm	8.9mm	6SMT	●
Würth	750340848	-40°C to 105°C	250V	3kVrms	–	–	2.2mm	4.4mm	9.1mm	4SMT	–
XFMR	XFBMC29-BA09	-40°C to 85°C	1600V (est)	2.9kVrms	●	●	5.0mm	10.0mm	19.5mm	6SMT	●

APPLICATIONS INFORMATION

Transformer Selection Guide

As shown in Figure 44, a transformer or pair of transformers are used to isolate the isoSPI signals between two isoSPI ports. The isoSPI signals have programmable pulse amplitudes up to $1.6V_{P-P}$ and pulse widths of 50ns and 150ns. To be able to transmit these pulses with the necessary fidelity the system requires that the transformers have primary inductances above $60\mu H$ and a 1:1 turns ratio. It is also necessary to use a transformer with less than $2.5\mu H$ of leakage inductance. In terms of pulse shape the primary inductance will mostly effect the pulse droop of the 50ns and 150ns pulses. If the primary inductance is too low the pulse amplitude will begin to droop and decay over the pulse period, if the pulse droop is severe the effective pulse width seen by the receiver will drop, reducing noise margin. Some droop is acceptable as long as it is a relatively small percentage of the total pulse amplitude. The leakage inductance will primarily effect the rise and fall times of the pulses. Slower rise and fall times will effectively reduce the pulse width. Pulse width is determined by the receiver as the time the signal is above the threshold set at the ICMP pin. This means that slow rise and fall times cut into the timing margins. Generally it is best to keep pulse edges as fast as possible. When evaluating transformers it is also worth noting is the parallel winding capacitance. While transformers have very good CMRR at low frequency, this rejection will degrade at higher frequencies and this is largely due to the winding to winding capacitance. So when choosing a transformer it is best to pick one with less parallel winding capacitance when possible.

When choosing a transformer it is equally important to pick a part that has an adequate isolation rating for the application. The working voltage rating of a transformer is a key spec when selecting a part for an applications. Interconnecting daisy chain links between LTC6810-1 devices will typically see $<60V$ stress, so ordinary pulse and LAN type transformers will suffice. Multi-drop connections and connections to the LTC6820 in general may need much higher working voltage ratings for good long-term reliability. Usually matching the working voltage to the voltage of the entire battery stack is conservative. Unfortunately, transformer vendors will often only specify one-second HV testing, and this is not equal to the

long-term ('permanent') rating of the part. For example, according to most safety standards a 1.5kV rated transformer is expected to handle 230V continuously, and a 3kV device is capable of 1100V long-term, though manufacturers may not always certify to those levels (refer to actual vendor data for specifics). Usually the higher voltage transformers are called 'high-isolation' or 'reinforced insulation' types by the suppliers. Table 56 shows a list of transformers that have been evaluated in isoSPI links.

In most applications a common mode choke is also necessary for noise rejection. Table 57 includes a list of suitable CMCs if the CMC is not already integrated into the transformer being used.

Table 57. Recommended Common Mode Chokes

MANUFACTURER	PART NUMBER
TDK	ACT45B-101-2P
Murata	DLW43SH101XK2

isoSPI Layout Guidelines

Layout of the isoSPI signal lines also plays a significant role in maximizing the noise immunity of a data link. The following layout guidelines are recommended:

1. The transformer should be placed as close to the isoSPI cable connector as possible. The distance should be kept less than 2cm. The LTC6810 should be placed close to but at least 1cm to 2cm away from the transformer to help isolate the IC from magnetic field coupling.
2. A V– ground plane should not extend under the transformer, the isoSPI connector, or in between the transformer and the connector.
3. The isoSPI signal traces should be as direct as possible while isolated from adjacent circuitry by ground metal or space. No traces should cross the isoSPI signal lines, unless separated by a ground plane on an inner layer.

System Supply Current

The LTC6810 has various supply current specifications for the different states of operation. The average supply current depends on the control loop in the system. It

APPLICATIONS INFORMATION

Table 58. Daisy Chain Serial Time Equations

COMMAND TYPE	CMD BYTES + CMD PEC	DATA BYTES + DATA PEC PER IC	TOTAL BITS	COMMUNICATION TIME
Read	4	8	$(4 + (8 \cdot \#ICs)) \cdot 8$	Total Bits • Clock Period
Write	4	8	$(4 + (8 \cdot \#ICs)) \cdot 8$	Total Bits • Clock Period
Operation	4	0	$4 \cdot 8 = 32$	$32 \cdot \text{Clock Period}$

Table 59. Multi-Drop Serial Time Equations

COMMAND TYPE	CMD BYTES + CMD PEC	DATA BYTES + DATA PEC PER IC	TOTAL BITS	COMMUNICATION TIME
Read	4	8	$((4 + 8) \cdot \#ICs) \cdot 8$	Total Bits • Clock Period
Write	4	8	$((4 + 8) \cdot \#ICs) \cdot 8$	Total Bits • Clock Period
Operation	4	0	$4 \cdot 8 = 32$	$32 \cdot \text{Clock Period}$

is necessary to know which commands are being executed each control loop cycle, and the duration of the control loop cycle. From this information it is possible to determine the percentage of time the LTC6810 is in the measure state versus the low power sleep state. The amount of isoSPI or SPI communication will also affect the average supply current.

Calculating Serial Throughput

For any given LTC6810 the calculation to determine communication time is simple, it is the number of bits in the transmission multiplied by the SPI clock period being used. The control protocol of the LTC6810 is very uniform so almost all commands can be categorized as a write, read or an operation. The tables below can be used to determine the number of bits in a given LTC6810 command. Table 58 can be used for daisy-chains and Table 59 for multi-drop networks.

ENHANCED APPLICATIONS

Current Measurement with a Hall-Effect Sensor

The LTC6810 auxiliary ADC inputs (GPIO pins) may be used for any analog signal, including active sensors with 0V to 5V analog outputs. For battery current measurements, Hall-effect sensors provide an isolated, low power solution. Figure 52 shows schematically a typical

Hall-Effect sensor that produces two outputs that proportion to the V_{CC} provided. The sensor in the figure has two bidirectional outputs centered at half of supply, CH1 is a 0A to 50A low range and CH2 is a 0A to 200A high range. The sensor is powered from a 5V source and produces analog outputs that are connected to GPIO pins or inputs of the MUX application shown in Figure 54. The use of GPIO1 and GPIO2 as the ADC inputs has the possibility of being digitized within the same conversion sequence as the cell inputs (using the ADCVAX command), thus synchronizing cell voltage and cell current measurements.

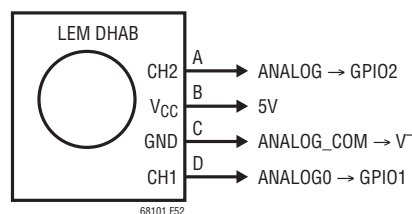

Figure 52. Interfacing a Typical Hall-Effect Battery Current Sensor to Auxiliary ADC Inputs

READING EXTERNAL TEMPERATURE PROBES

Figure 53 shows the typical biasing circuit for a negative-temperature-coefficient (NTC) thermistor. The 10kΩ @ 25°C is the most popular sensor value and the V_{REF2} output stage is designed to provide the current required to bias several of these probes. The biasing resistor is

APPLICATIONS INFORMATION

selected to correspond to the NTC value so the circuit will provide 1.5V at 25°C (V_{REF2} is 3V nominal). The overall circuit response is approximately $-1\%/^{\circ}\text{C}$ in the range of typical cell temperatures, as shown in the chart of Figure 53.

Expanding the Number of Auxiliary Measurements

The LTC6810 has five GPIO pins that can be used as ADC inputs. In applications that need to measure more than five signals a multiplexer (MUX) circuit can be implemented to expand the analog measurements to sixteen different signals (Figure 54). The GPIO1 ADC input is used for measurement and MUX control is provided by the I²C port on GPIO3 and GPIO4. The buffer amplifier was selected for fast settling and will increase the usable throughput rate.

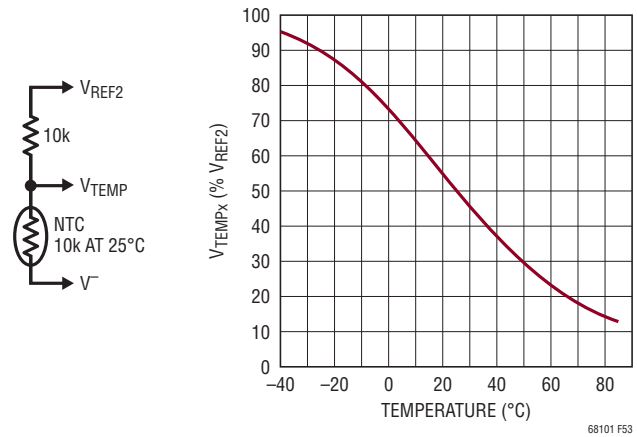

Figure 53. Typical Temperature Probe Circuit and Relative Output

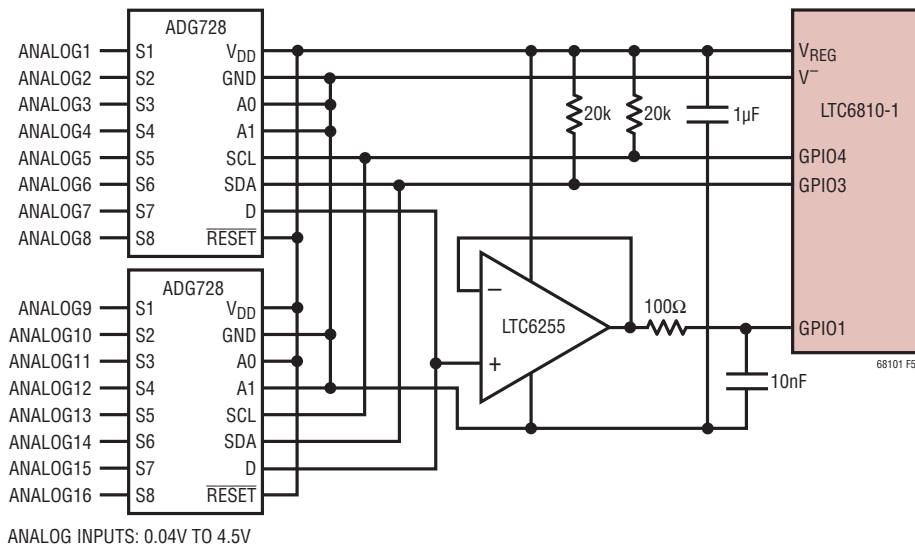
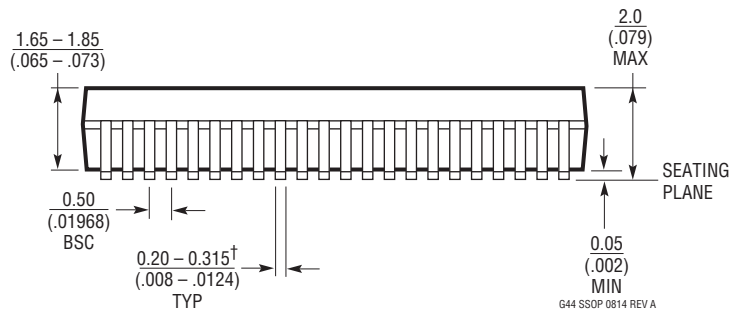
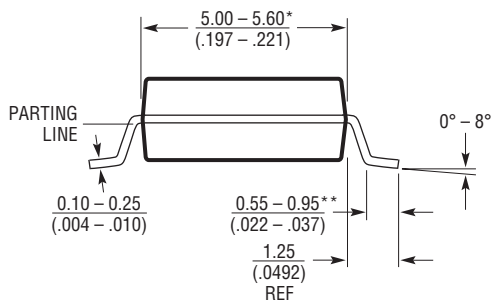
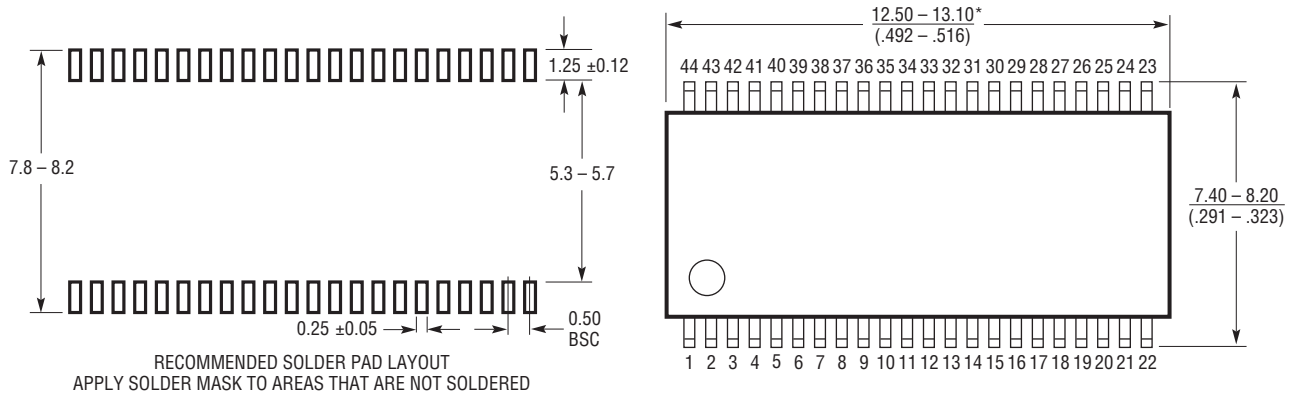

Figure 54. MUX Circuit Supports Sixteen Additional Analog Measurements

PACKAGE DESCRIPTION

G Package 44-Lead Plastic SSOP (5.3mm) (Reference LTC DWG # 05-08-1754 Rev A)



NOTE:

1. DRAWING IS NOT A JEDEC OUTLINE
2. CONTROLLING DIMENSION: MILLIMETERS
3. DIMENSIONS ARE IN $\frac{\text{MILLIMETERS}}{\text{(INCHES)}}$
4. DRAWING NOT TO SCALE
5. FORMED LEADS SHALL BE PLANAR WITH RESPECT TO ONE ANOTHER WITHIN 0.08mm AT SEATING PLANE

*DIMENSIONS DO NOT INCLUDE MOLD FLASH OR PROTRUSIONS, BUT DO INCLUDE MOLD MISMATCH AND ARE MEASURED AT THE PARTING LINE. MOLD FLASH SHALL NOT EXCEED .15mm PER SIDE

**LENGTH OF LEAD FOR SOLDERING TO A SUBSTRATE

†THE MAXIMUM DIMENSION DOES NOT INCLUDE DAMBAR PROTRUSIONS. DAMBAR PROTRUSIONS DO NOT EXCEED 0.13mm PER SIDE

REVISION HISTORY

REV	DATE	DESCRIPTION	PAGE NUMBER
A	03/20	Added Automotive Qualification to Front Page Features	1
		Order Information Updated	4
		Electrical Characteristics, Sum of Cells Corrected to $\pm 0.6V$ MAX	5
		Electrical Characteristics, Receiver Voltage Range Removed	8
		Figure 15 Title Corrected: ADCVSC Replaced with ADVCAx	33
		Table 56. Recommended Transformers List Updated	81
		Related Parts Table Updated	86
B	10/22	Corrected a typo on cell voltage register and added missing info for S voltage register	36
		Removed unsupported authentication feature	2, 45

TYPICAL APPLICATION

Basic 6-Cell Monitor with isoSPI Daisy Chain

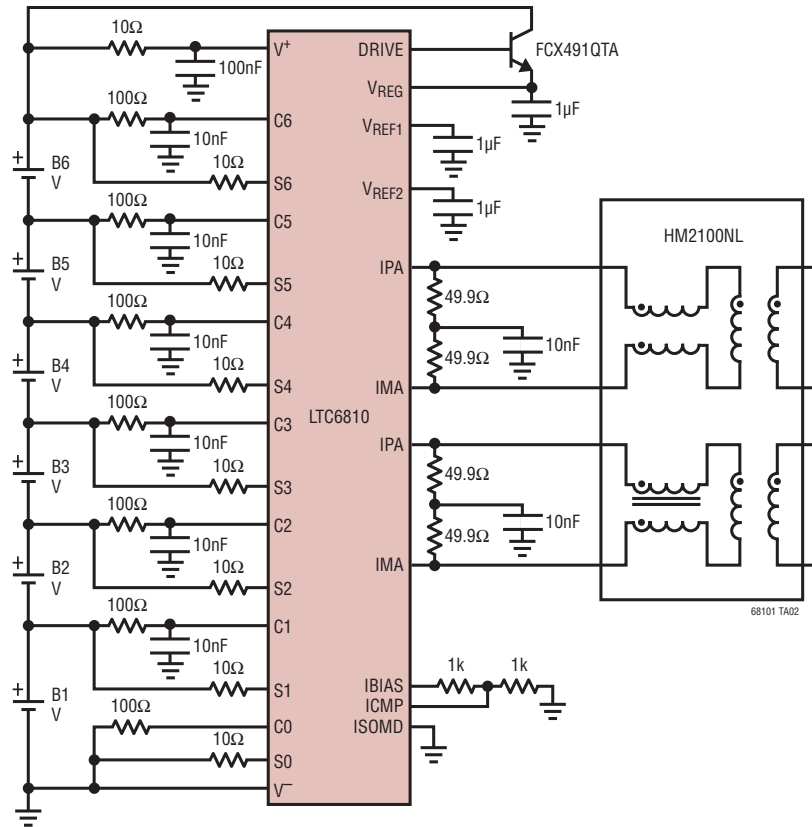

RELATED PARTS

PART NUMBER	DESCRIPTION	COMMENTS
LTC6804	3rd Generation 12-Cell Battery Stack Monitor and Balancing IC	Measures Cell Voltages for Up to 12 Series Battery Cells. Daisy-Chain Capability Allows Multiple Devices to Be Connected to Measure 100s of Battery Cells Simultaneously Via the Built-In 1MHz, 2-Wire Isolated Communication (isoSPI). Includes Capability for Passive Cell Balancing.
LTC6811	4th Generation 12-Cell Battery Stack Monitor and Balancing IC	Measures Cell Voltages for Up To 12 Series Battery Cells. Daisy-Chain Capability Allows Multiple Devices to Be Connected to Measure 100s of Battery Cells Simultaneously Via the Built-In 1MHz, 2-Wire Isolated Communication (isoSPI). Includes Capability for Passive Cell Balancing.
LTC6812	4th Generation 15-Cell Battery Stack Monitor and Balancing IC	Measures Cell Voltages for Up to 15 Series Battery Cells. The isoSPI Daisy-Chain Capability Allows Multiple Devices to be Interconnected for Measuring Many Battery Cells Simultaneously. The isoSPI Bus can Operate Up to 1MHz and can be Operated Bidirectionally for Fault Conditions, such as a Broken Wire or Connector. Includes Internal Passive CellBalancing Capability of Up to 200mA.
LTC6813	4th Generation 18-Cell Battery Stack Monitor and Balancing IC	Measures Cell Voltages for Up to 18 Series Battery Cells. The isoSPI Daisy-Chain Capability Allows Multiple Devices to be Interconnected for Measuring Many Battery Cells Simultaneously. The isoSPI Bus can Operate Up to 1MHz and can be Operated Bidirectionally for Fault Conditions, such as a Broken Wire or Connector. Includes Internal Passive CellBalancing Capability of Up to 200mA.
LTC6820	isoSPI Isolated Communications Interface	Provides an Isolated Interface for SPI Communication Up to 100 Meters, Using a Twisted Pair. Companion to the LTC6804, LTC6806, LTC6810, LTC6811, LTC6812 and LTC6813.

Rev. B

Looking for pricing, stock, or lifecycle information?

Click below to explore more details on WIN SOURCE:

- ⊖ [View LTC6810IG-2#3ZZPBF on WIN SOURCE](#)
- ⊖ [Analog Devices Inc. Information](#)

Optimize Your Supply Chain with WIN SOURCE Solutions

- ✓ Global Sourcing Solution
- ✓ Obsolete Management
- ✓ Cost Control Management
- ✓ Shortage Management
- ✓ Alternative Solution
- ✓ Excess Inventory Management