



**THE DATASHEET OF
LTC5594IUH#PBF**



300MHz to 9GHz High Linearity I/Q Demodulator with Wideband IF Amplifier

FEATURES

- True Zero IF Demodulation
- Wideband Input Matched from 500MHz to 9GHz
- Wide IF Bandwidth: DC to 1GHz (1dB Flatness)
- 37dB Image Rejection, Adjustable to 60dB
- High Total OIP3: 37dBm at 5.8GHz
- 58dBm OIP2 at 5.8GHz, Adjustable to 65dBm
- Max Power Conversion Gain: 9.2dB at 5.8GHz
- Single-Ended RF Input with On-Chip Transformer
- User Adjustable DC Offset Null
- Serial Interface
- IF Amplifier Gain Adjustable in Eight Steps
- IF Amplifier Shutdown/Enable
- Low Power Shutdown Mode
- Operating Temperature Range (T_C): -40°C to 105°C
- 32-Lead $5\text{mm} \times 5\text{mm}$ QFN Package

APPLICATIONS

- 5G Base Station Fronthaul/Backhaul Receivers
- Military and Satellite Receivers
- Point-to-Point Broadband Radios
- High Linearity Direct Conversion I/Q SDR
- Test Instrumentation
- DPD Receivers

DESCRIPTION

The LTC[®]5594 is a direct conversion quadrature demodulator optimized for high linearity zero-IF and low-IF receiver applications in the 300MHz to 9GHz frequency range. The very wide IF bandwidth of more than 1GHz makes the LTC5594 particularly suited for demodulation of very wideband signals, especially in 5G fronthaul/backhaul receiver applications. The outstanding dynamic range of the LTC5594 makes the device suitable for demanding infrastructure direct conversion applications. Proprietary technology inside the LTC5594 provides the capability to optimize OIP2 to 65dBm, and achieve image rejection better than 60dB. The DC offset control function allows nulling of the DC offset at the A/D converter input, thereby optimizing the dynamic range of true zero-IF receivers that use DC-coupled IF signal paths. The wideband RF and LO input ports make it possible to cover all the major wireless infrastructure frequency bands using a single device. The IF outputs of the LTC5594 are designed to interface directly with most common A/D converter input interfaces. The high OIP3 and high conversion gain of the device eliminate the need for additional amplifiers in the IF signal path.

All registered trademarks and trademarks are the property of their respective owners.

TYPICAL APPLICATION

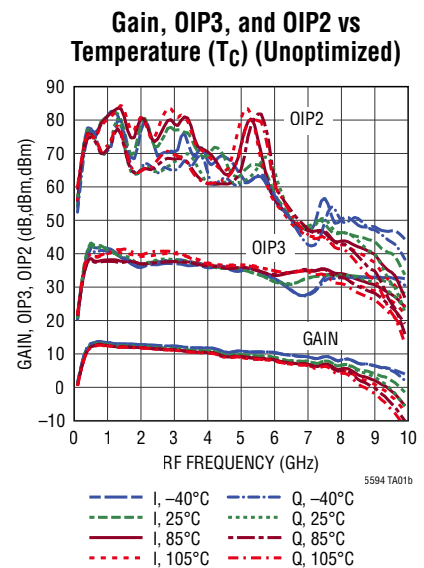
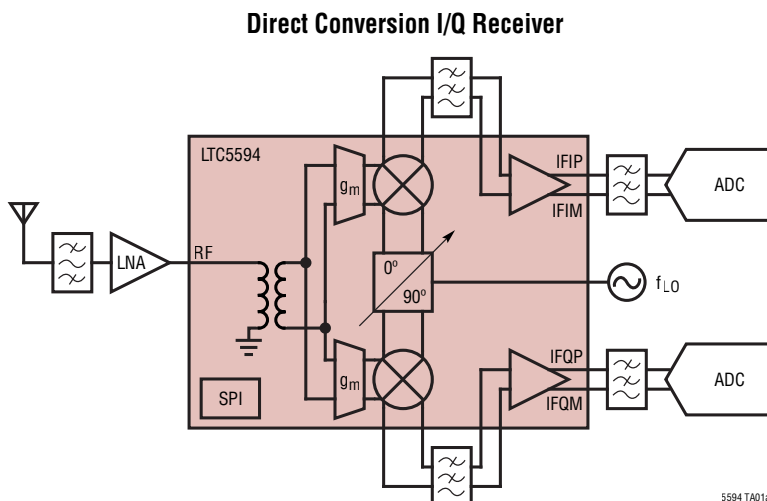

LTC5594

ABSOLUTE MAXIMUM RATINGS

(Note 1)

V_{CC} Supply Voltage (Note 23)	−0.3V to 5.5V
OV_{DD} , SDO Voltage (Note 20)	−0.3V to 3.8V
RF DC Voltage	1.5V to 2.0V
LOP, LOM DC Voltage	2.1V to 2.8V
IFIM, IFIP, IFQP, IFQM DC Voltage	−0.3V to 3.5V
AIM, AIP, AQM, AQP	
DC Voltage	$V_{CC} - 1.7V$ to $V_{CC} - 1.2V$
MIM, MIP, MQM, MQP	
DC Voltage	$V_{CC} - 1.7V$ to $V_{CC} - 1.2V$
Voltage on Any Other Pin	−0.3V to 5.5V
LOP, LOM, RF Input Power (Note 19)	+20dBm
Output Short Circuit Duration (Notes 16, 19)	Indefinite
Maximum Junction Temperature (T_{JMAX})	150°C
Case Operating Temperature	
Range (T_C)	−40°C to 105°C
Storage Temperature Range	−65°C to 150°C

PIN CONFIGURATION

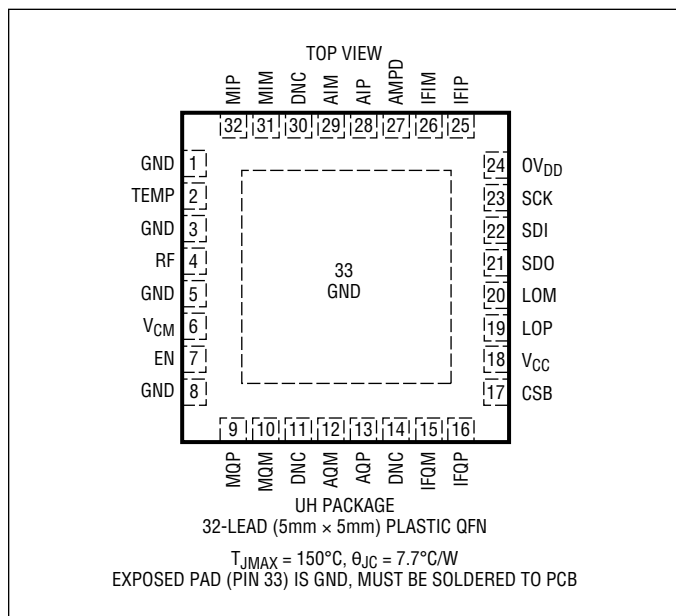

ORDER INFORMATION

LEAD FREE FINISH	TAPE AND REEL	PART MARKING	PACKAGE DESCRIPTION	TEMPERATURE RANGE
LTC5594IUH#PBF	LTC5594IUH#TRPBF	5594	32-Lead (5mm x 5mm) Plastic QFN	−40°C to 105°C

Consult ADI Marketing for parts specified with wider operating temperature ranges.

[Tape and reel specifications](#). Some packages are available in 500 unit reels through designated sales channels with #TRMPBF suffix.

ELECTRICAL CHARACTERISTICS

$T_C = 25^\circ\text{C}$, $V_{CC} = 5\text{V}$, $0V_{DD} = EN = CSB = 3.3\text{V}$, $SDI = SCK = AMPD = 0\text{V}$, $V_{CM} = 0.9\text{V}$, $P_{IF} = 1.5\text{dBm}$ ($-1.5\text{dBm}/\text{tone}$ for 2-tone tests), $P_{LO} = 6\text{dBm}$, all registers at default values, and all parameters listed for combined performance of demodulator and amplifier unless otherwise noted. (Notes 2, 3, 6, 9, 21, 24)

SYMBOL	PARAMETER	CONDITIONS	MIN	TYP	MAX	UNITS
$f_{RF(\text{RANGE})}$	RF Input Frequency Range	(Note 12)		0.3 to 9.0		GHz
$f_{LO(\text{RANGE})}$	LO Input Frequency Range	(Note 12)		0.3 to 9.0		GHz
BW_{IF}	IF Output Bandwidth	-1dB Corner Frequency (Note 22)		1.0		GHz
RL_{RF}	RF Input Return Loss (Note 5)	$f_{RF} = 300\text{MHz}$ to 500MHz $f_{RF} = 500\text{MHz}$ to 9.0GHz		>10 >10		dB dB
RL_{LO}	LO Input Return Loss	$f_{LO} = 300\text{MHz}$ to 9.0GHz		>10		dB
$P_{LO(\text{RANGE})}$	LO Input Power Range	(Note 12)		-6 to 12		dBm
G_p	Power Conversion Gain AMPG = 0x06, $R_{LOAD} = 100\Omega$ Differential (Note 8)	$f_{RF} = 400\text{MHz}$ $f_{RF} = 1900\text{MHz}$ $f_{RF} = 3500\text{MHz}$ $f_{RF} = 5800\text{MHz}$ $f_{RF} = 7200\text{MHz}$ $f_{RF} = 8500\text{MHz}$		11.5 12.3 11.0 9.2 7.0 5.2		dB dB dB dB dB dB
NF	Noise Figure, Double Side Band (Note 4)	$f_{RF} = 400\text{MHz}$ $f_{RF} = 1900\text{MHz}$ $f_{RF} = 3500\text{MHz}$ $f_{RF} = 5800\text{MHz}$ $f_{RF} = 7200\text{MHz}$ $f_{RF} = 8500\text{MHz}$		15.7 16.0 17.9 21.2 23.5 28.6		dB dB dB dB dB dB
NF_{BLOCKING}	Noise Figure Under Blocking Conditions Double Side Band, $P_{IF, \text{BLOCKER}} = 1.5\text{dBm}$ (Note 7)	$f_{RF} = 400\text{MHz}$ $f_{RF} = 1900\text{MHz}$ $f_{RF} = 3500\text{MHz}$ $f_{RF} = 5800\text{MHz}$ $f_{RF} = 7200\text{MHz}$ $f_{RF} = 8500\text{MHz}$		16.7 17.0 18.9 22.2 24.5 29.6		dB dB dB dB dB dB
OIP3	Output 3rd Order Intercept Unadjusted/Adjusted	$f_{RF} = 400\text{MHz}$ $f_{RF} = 1900\text{MHz}$ $f_{RF} = 3500\text{MHz}$ $f_{RF} = 5800\text{MHz}$ $f_{RF} = 7200\text{MHz}$ $f_{RF} = 8500\text{MHz}$		40/44 37/43 37/42 37/40 33/38 33/35		dBm dBm dBm dBm dBm dBm
OIP2	Output 2nd Order Intercept Unadjusted/Adjusted	$f_{RF} = 400\text{MHz}$ $f_{RF} = 1900\text{MHz}$ $f_{RF} = 3500\text{MHz}$ $f_{RF} = 5800\text{MHz}$ $f_{RF} = 7200\text{MHz}$ $f_{RF} = 8500\text{MHz}$		75/80 68/75 68/70 58/65 48/55 43/48		dBm dBm dBm dBm dBm dBm
$IIP3_{\text{DEMOD}}$	Input 3rd Order Intercept without Amplifier Unadjusted	$f_{RF} = 400\text{MHz}$ $f_{RF} = 1900\text{MHz}$ $f_{RF} = 3500\text{MHz}$ $f_{RF} = 5800\text{MHz}$ $f_{RF} = 7200\text{MHz}$ $f_{RF} = 8500\text{MHz}$		30 26 27 24 24 27		dBm dBm dBm dBm dBm dBm
$OIP3_{\text{AMP}}$	Output 3rd Order Intercept, Amplifier Only (Note 17)	$f_{IF} = 10\text{MHz}$ $f_{IF} = 100\text{MHz}$ $f_{IF} = 200\text{MHz}$ $f_{IF} = 300\text{MHz}$ $f_{IF} = 500\text{MHz}$ $f_{IF} = 1000\text{MHz}$		42 41 38 37 35 30		dBm dBm dBm dBm dBm dBm

ELECTRICAL CHARACTERISTICS

$T_C = 25^\circ\text{C}$, $V_{CC} = 5\text{V}$, $0V_{DD} = EN = CSB = 3.3\text{V}$, $SDI = SCK = AMPD = 0\text{V}$, $V_{CM} = 0.9\text{V}$, $P_{IF} = 1.5\text{dBm}$ ($-1.5\text{dBm}/\text{tone}$ for 2-tone tests), $P_{LO} = 6\text{dBm}$, all registers at default values, and all parameters listed for combined performance of demodulator and amplifier unless otherwise noted. (Notes 2, 3, 6, 9, 21, 24)

SYMBOL	PARAMETER	CONDITIONS	MIN	TYP	MAX	UNITS
HD2	2nd Order Harmonic Distortion Unadjusted/Adjusted	$f_{RF} = 400\text{MHz}$		-65		dBc
		$f_{RF} = 1900\text{MHz}$		-64		dBc
		$f_{RF} = 3500\text{MHz}$		-60		dBc
		$f_{RF} = 5800\text{MHz}$		-56		dBc
		$f_{RF} = 7200\text{MHz}$		-50		dBc
		$f_{RF} = 8500\text{MHz}$		-46		dBc
HD3	3rd Order Harmonic Distortion Unadjusted/Adjusted	$f_{RF} = 400\text{MHz}$		-82		dBc
		$f_{RF} = 1900\text{MHz}$		-80		dBc
		$f_{RF} = 3500\text{MHz}$		-76		dBc
		$f_{RF} = 5800\text{MHz}$		-70		dBc
		$f_{RF} = 7200\text{MHz}$		-65		dBc
		$f_{RF} = 8500\text{MHz}$		-68		dBc
P1dB	Output 1dB Compression Point	$f_{RF} = 400\text{MHz}$		13.2		dBm
		$f_{RF} = 1900\text{MHz}$		13.2		dBm
		$f_{RF} = 3500\text{MHz}$		13.2		dBm
		$f_{RF} = 5800\text{MHz}$		13.2		dBm
		$f_{RF} = 7200\text{MHz}$		13.2		dBm
		$f_{RF} = 8500\text{MHz}$		13.2		dBm
DC _{OFFSET}	DC Offset, Unadjusted (Note 13)	$f_{RF} = 400\text{MHz}$		19		mV
		$f_{RF} = 1900\text{MHz}$		17		mV
		$f_{RF} = 3500\text{MHz}$		17		mV
		$f_{RF} = 5800\text{MHz}$		-26		mV
		$f_{RF} = 7200\text{MHz}$		-63		mV
		$f_{RF} = 8500\text{MHz}$		-19		mV
DC _{OFF(RANGE)}	DC Offset Adjustment Range	DCOI, DCOQ = 0x00 to 0xFF		-75 to 75		mV
DC _{OFF(STEP)}	DC Offset Step Size			640		μV
ΔG	I/Q Gain Mismatch, Unadjusted	$f_{RF} = 400\text{MHz}$		0.05		dB
		$f_{RF} = 1900\text{MHz}$		0.05		dB
		$f_{RF} = 3500\text{MHz}$		0.06		dB
		$f_{RF} = 5800\text{MHz}$		0.06		dB
		$f_{RF} = 7200\text{MHz}$		0.07		dB
		$f_{RF} = 8500\text{MHz}$		0.44		dB
$\Delta\text{G(RANGE)}$	I/Q Gain Mismatch Adjustment Range	GERR = 0x00 to 0x3F		-0.5 to 0.5		dB
$\Delta\text{G(STEP)}$	I/Q Gain Mismatch Adjustment Step Size			0.016		dB
$\Delta\phi$	I/Q Phase Mismatch, Unadjusted	$f_{RF} = 400\text{MHz}$		0.9		Deg
		$f_{RF} = 1900\text{MHz}$		1.1		Deg
		$f_{RF} = 3500\text{MHz}$		3.1		Deg
		$f_{RF} = 5800\text{MHz}$		1.6		Deg
		$f_{RF} = 7200\text{MHz}$		1.1		Deg
		$f_{RF} = 8500\text{MHz}$		1.0		Deg
$\Delta\phi(\text{RANGE})$	I/Q Phase Mismatch Adjustment Range	PHA = 0x000 to 0x1FF		-2.5 to 2.5		Deg
$\Delta\phi(\text{STEP})$	I/Q Phase Mismatch Adjustment Step Size			0.05		Deg
IRR	Image Rejection Ratio Unadjusted/Adjusted (Note 10)	$f_{RF} = 400\text{MHz}$		43/70		dB
		$f_{RF} = 1900\text{MHz}$		42/65		dB
		$f_{RF} = 3500\text{MHz}$		33/65		dB
		$f_{RF} = 5800\text{MHz}$		37/60		dB
		$f_{RF} = 7200\text{MHz}$		40/60		dB
		$f_{RF} = 8500\text{MHz}$		33/60		dB

ELECTRICAL CHARACTERISTICS

$T_C = 25^\circ\text{C}$, $V_{CC} = 5\text{V}$, $OV_{DD} = EN = CSB = 3.3\text{V}$, $SDI = SCK = AMPD = 0\text{V}$, $V_{CM} = 0.9\text{V}$, $P_{IF} = 1.5\text{dBm}$ (-1.5dBm /tone for 2-tone tests), $P_{LO} = 6\text{dBm}$, all registers at default values, and all parameters listed for combined performance of demodulator and amplifier unless otherwise noted. (Notes 2, 3, 6, 9, 21, 24)

SYMBOL	PARAMETER	CONDITIONS	MIN	TYP	MAX	UNITS
LR _{LEAK}	LO to RF Leakage	$f_{LO} = 400\text{MHz}$		-67		dBm
		$f_{LO} = 1900\text{MHz}$		-65		dBm
		$f_{LO} = 3500\text{MHz}$		-56		dBm
		$f_{LO} = 5800\text{MHz}$		-52		dBm
		$f_{LO} = 7200\text{MHz}$		-50		dBm
		$f_{LO} = 8500\text{MHz}$		-55		dBm
RL _{ISO}	RF to LO Isolation	$f_{RF} = 400\text{MHz}$		69		dB
		$f_{RF} = 1900\text{MHz}$		57		dB
		$f_{RF} = 3500\text{MHz}$		66		dB
		$f_{RF} = 5800\text{MHz}$		55		dB
		$f_{RF} = 7200\text{MHz}$		57		dB
		$f_{RF} = 8500\text{MHz}$		53		dB
RI _{ISO}	RF to IF Isolation (Note 18)	$f_{RF} = 400\text{MHz}$		70		dB
		$f_{RF} = 1900\text{MHz}$		48		dB
		$f_{RF} = 3500\text{MHz}$		59		dB
		$f_{RF} = 5800\text{MHz}$		48		dB
		$f_{RF} = 7200\text{MHz}$		40		dB
		$f_{RF} = 8500\text{MHz}$		43		dB
LI _{ISO}	LO to IF Isolation (Note 18)	$f_{LO} = 400\text{MHz}$		40		dB
		$f_{LO} = 1900\text{MHz}$		29		dB
		$f_{LO} = 3500\text{MHz}$		38		dB
		$f_{LO} = 5800\text{MHz}$		36		dB
		$f_{LO} = 7200\text{MHz}$		33		dB
		$f_{LO} = 8500\text{MHz}$		35		dB

Power Supply and Other Parameters

V_{CC}	Supply Voltage		4.75	5.0	5.25	V
I_{CC}	Supply Current		450	470	500	mA
$I_{CC(MIX)}$	Mixer Supply Current	Amplifier Disabled, AMPD = 3.3V	230	250	270	mA
$I_{CC(OFF)}$	Shutdown Current	EN < 0.3V		20	900	μA
$I_{CC(SLEEP)}$	Sleep Current	EDEM = EDC = EADJ = EAMP = 0		4		mA
t_{ON}	Turn-On Time (Note 14)	EN Transition from Logic Low to High		1		μs
t_{OFF}	Turn-Off Time (Note 15)	EN Transition from Logic High to Low		1		μs
OV_{DD}	Digital I/O Supply Voltage			1.2 to 3.3		V
V_{DH}	EN Input High Voltage (On)		$0.7 \cdot OV_{DD}$			V
V_{DL}	EN Input Low Voltage (Off)			$0.3 \cdot OV_{DD}$		V
I_{EN}	EN Pin Input Current	EN = 3.3V		41		μA
V_{TEMP}	TEMP Diode Bias Voltage	$I_{TEMP} = 100\mu\text{A}$ into TEMP Pin, $T_J = 25^\circ\text{C}$		0.774		V
	TEMP Diode Temperature Slope	$I_{TEMP} = 100\mu\text{A}$ into TEMP Pin		-1.52		$\text{mV}/^\circ\text{C}$
$Z_{MIX(OUT)}$	Mixer Output Impedance	Differential		100 0.6		ΩpF
$V_{MIX(OUT)}$	Mixer Output DC Voltage	Common Mode		3.6		V
$Z_{AMP(IN)}$	Amplifier Input Impedance	Differential		200 0.2		ΩpF
$V_{AMP(IN)}$	Amplifier DC Input Voltage	Common Mode		3.6		V
$Z_{AMP(OUT)}$	Amplifier Output Impedance	Differential		4 0.5		$\text{k}\Omega \text{pF}$
$I_{AMP(SC)}$	Amplifier DC Output Short Circuit Current	IFIP = IFIM = IFQP = IFQM = 0V		100		mA
$V_{CM(RANGE)}$	V_{CM} Pin Voltage Range (Notes 11, 12)			0.5 to 2.0		V

ELECTRICAL CHARACTERISTICS

$T_C = 25^\circ\text{C}$, $V_{CC} = 5\text{V}$, $OV_{DD} = EN = CSB = 3.3\text{V}$, $SDI = SCK = AMPD = 0\text{V}$, $V_{CM} = 0.9\text{V}$, $P_{IF} = 1.5\text{dBm}$ ($-1.5\text{dBm}/\text{tone}$ for 2-tone tests), $P_{LO} = 6\text{dBm}$, all registers at default values, and all parameters listed for combined performance of demodulator and amplifier unless otherwise noted. (Notes 2, 3, 6, 9, 21, 24)

SYMBOL	PARAMETER	CONDITIONS	MIN	TYP	MAX	UNITS
Serial Interface Pins						
V_{IH}	High Level Input Voltage	CSB, SDI, SCK	$0.7 \cdot OV_{DD}$			V
V_{IL}	Low Level Input Voltage	CSB, SDI, SCK			$0.3 \cdot OV_{DD}$	V
V_{IHYS}	Input Hysteresis Voltage	CSB, SDI, SCK		250		mV
$I_{IN(SER)}$	Input Current	CSB, SDI, SCK (Note 19)			10	μA
V_{OH}	High Level Output Voltage	SDO, 10mA Current Sink	$0.7 \cdot OV_{DD}$			V
V_{OL}	Low Level Output Voltage	SDO, 10mA Current Source			$0.3 \cdot OV_{DD}$	V
Serial Interface Timing						
t_{CKH}	SCK High Time		25			ns
t_{CKL}	SCK Low Time		25			ns
t_{CSS}	CSB Setup Time		10			ns
t_{CSH}	CSB High Time		10			ns
t_{DS}	SDI to SCK Setup Time		6			ns
t_{DH}	SDI to SCK Hold Time		6			ns
t_{DO}	SCK to SDO Time	To $V_{IH}/V_{IL}/\text{Hi-Z}$ with 30pF Load			16	ns

Note 1: Stresses beyond those listed under Absolute Maximum Ratings may cause permanent damage to the device. Exposure to any Absolute Maximum Rating condition for extended periods may affect device reliability and lifetime. The voltage on all pins should not exceed $V_{CC} + 0.3\text{V}$ or be less than -0.3V , otherwise damage to the ESD diodes may occur.

Note 2: Tests are performed with the test circuit of Figure 1.

Note 3: The LTC5594 is guaranteed to be functional over the -40°C to 105°C case temperature operating range.

Note 4: DSB noise figure is measured at the baseband frequency of 15MHz with a small-signal noise source without any filtering on the RF input and no other RF signal applied.

Note 5: A 6.8pF shunt capacitor is used on the RF inputs for 300MHz to 500MHz. 0.2pF is used for 500MHz to 9GHz.

Note 6: The differential amplifier outputs (IFIP, IFIM and IFQP, IFQM) are combined using a 180° combiner.

Note 7: Noise figure under blocking conditions (NF_{BLOCKING}) is measured at an output frequency of 60MHz with RF input signal at $f_{LO} + 1\text{MHz}$. Both RF and LO input signals are appropriately filtered, as well as the baseband output.

Note 8: Power conversion gain is defined from the RF input to the I or Q output. Power conversion gain is measured with a 100Ω differential load impedance on the I and Q outputs. Any losses due to IF combiner and spectrum analyzer termination have been de-embedded.

Note 9: Input P_{RF} adjusted so that $P_{IF} = -1.5\text{dBm}/\text{tone}$ at the amplifier output. RF tone spacing set at 4MHz with high side LO, $f_{LO} = f_{RF} + 30\text{MHz}$.

Note 10: Image rejection is measured at $f_{IF} = 12\text{MHz}$ and calculated from the measured gain error and phase error.

Note 11: If the V_{CM} pin is left floating, it will self bias to a nominal 0.9V.

Note 12: This is the recommended operating range, operation outside the listed range is possible with degraded performance to some parameters.

Note 13: DC offset measured differentially between IFIP and IFIM and between IFQP and IFQM. The reported value is the mean of the absolute values of the characterization data distribution.

Note 14: IF amplitude is within 10% of final value.

Note 15: IF amplitude is at least 30dB down from its on state.

Note 16: IF outputs shorted to ground.

Note 17: IF tone spacing set at 1MHz.

Note 18: Worst case isolation measured to each IF single-ended port.

Note 19: Guaranteed by design characterization, not tested in production.

Note 20: The voltage on the OV_{DD} pin must never exceed $V_{CC} + 0.3\text{V}$, otherwise damage to the ESD diodes may occur.

Note 21: Refer to Appendix for register definition and default values.

Note 22: Mixer outputs directly connected to amplifier inputs. Bandwidth measured on single amplifier output, I or Q.

Note 23: V_{CC} should be ramped up slower than 5V/ms to prevent damage.

Note 24: P_{IF} measured at amplifier differential outputs.

TYPICAL PERFORMANCE CHARACTERISTICS $V_{CC} = 5V$, $EN = 3.3V$, $T_C = 25^\circ C$, $P_{LO} = 6dBm$, $HSLO$, RF tone spacing = 4MHz, $f_{IF} = 30MHz$, $P_{IF} = -1.5dBm$ per tone, and register defaults. DC Blocks, 50Ω terminations, and MACOM H9 180° combiner at amplifier outputs de-embedded from measurement unless otherwise noted. Test circuit shown in Figure 1 with 1GHz interstage filter.

Supply Current vs Supply Voltage

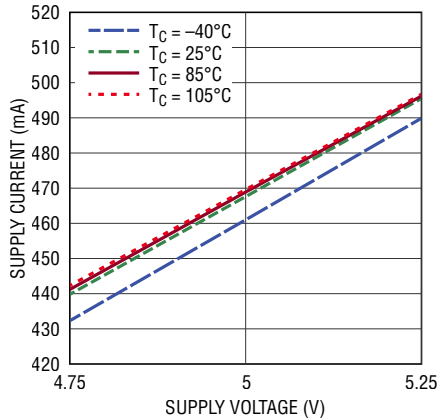

TEMP Diode Voltage vs Junction Temperature (T_J)

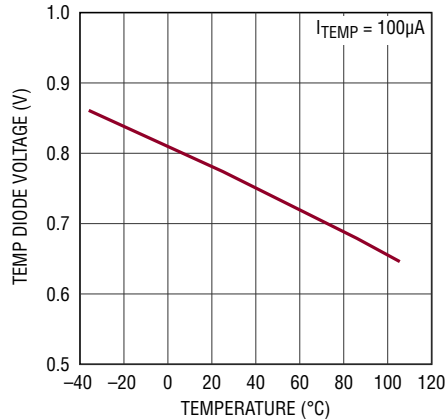

Noise Figure and Conversion Gain vs Temperature (T_C)

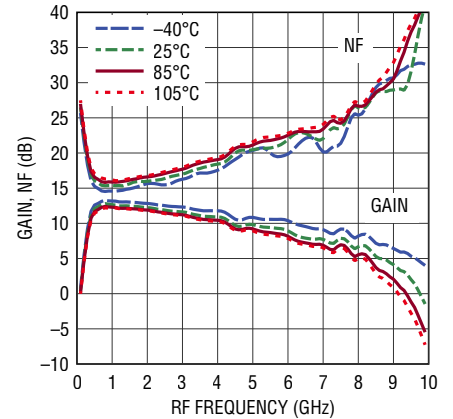

Noise Figure and Conversion Gain vs LO Power

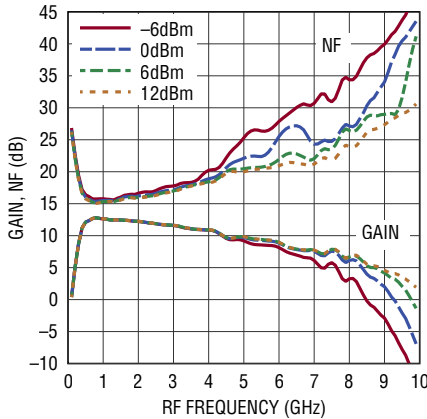

Gain vs IF Frequency for Various Fixed LO Frequencies

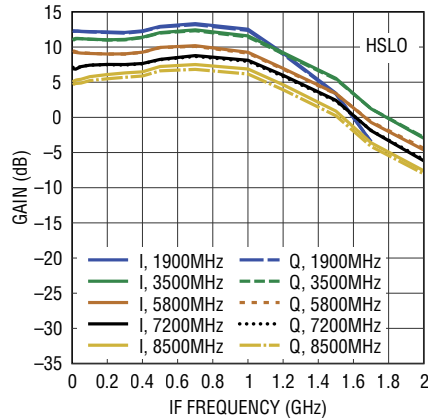

Gain vs IF Frequency for Various Fixed LO Frequencies

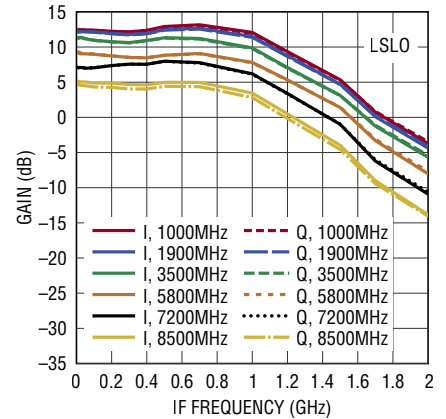

Gain vs AMPG Register Value

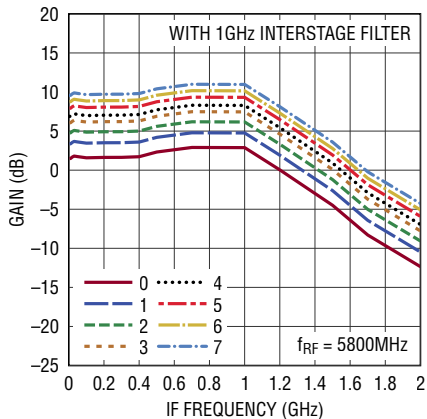

OIP3 vs RF Frequency for Various Fixed IF Frequencies

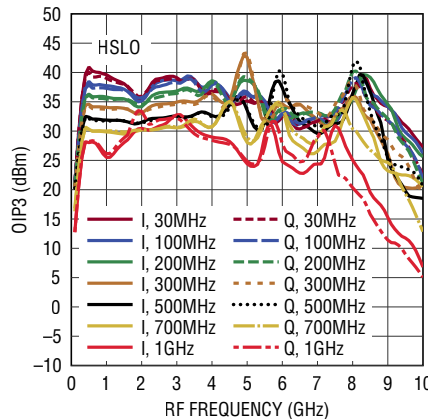

OIP3 vs RF Frequency for Various Fixed IF Frequencies

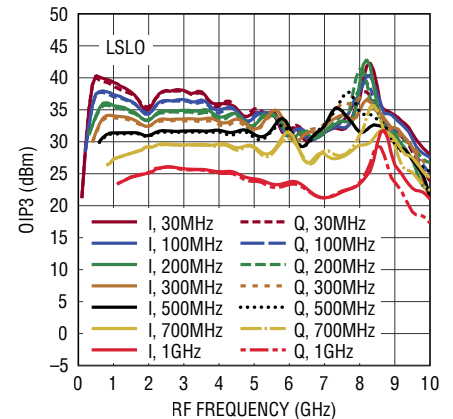

TYPICAL PERFORMANCE CHARACTERISTICS $V_{CC} = 5V$, $EN = 3.3V$, $T_C = 25^\circ C$, $P_{L0} = 6dBm$, HSL0, RF tone spacing = 4MHz, $f_{IF} = 30MHz$, $P_{IF} = -1.5dBm$ per tone, and register defaults. DC Blocks, 50Ω terminations, and MACOM H9 180° combiner at amplifier outputs de-embedded from measurement unless otherwise noted. Test circuit shown in Figure 1 with 1GHz interstage filter.

OIP3 vs Temperature (T_C)

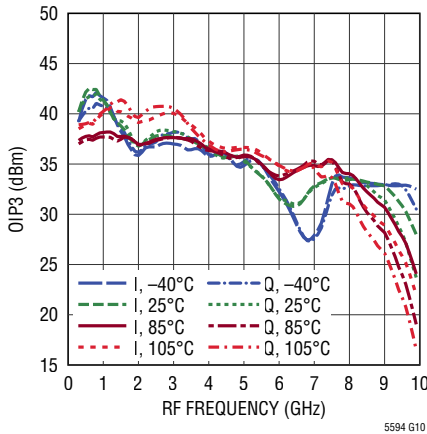

OIP3 vs Supply Voltage (V_{CC})

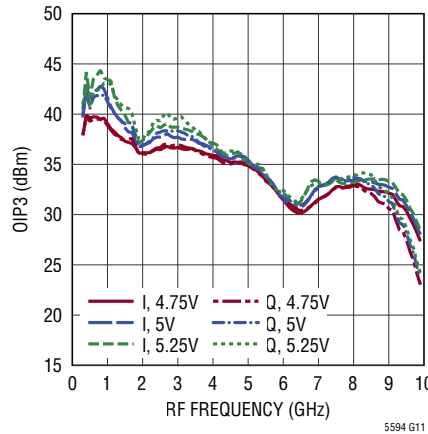

OIP3 vs LO Power

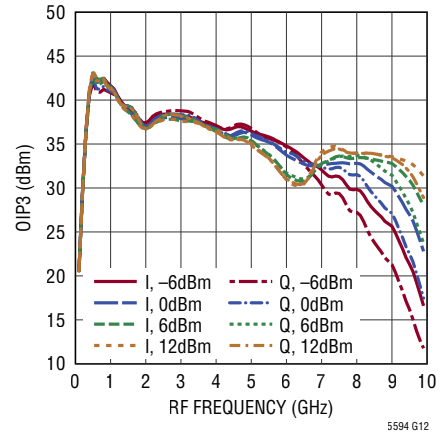

OIP3 vs IF Tone Power

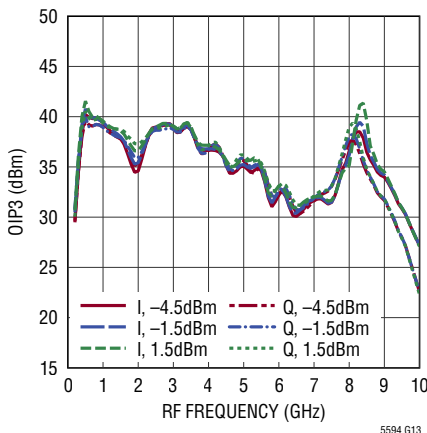

Optimized OIP3 vs Temperature (T_C)

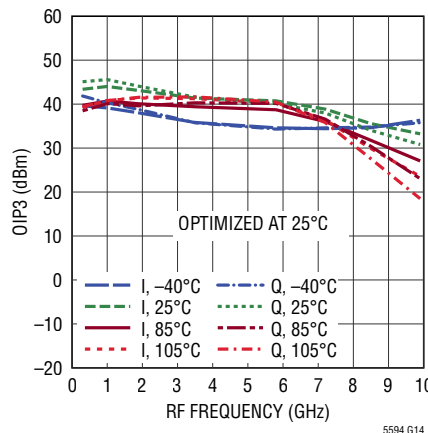

OIP3 vs Temperature (T_C) and Register Value

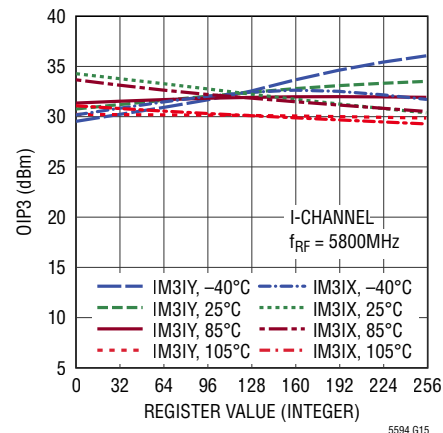

OIP3 vs Temperature (T_C) and Register Value

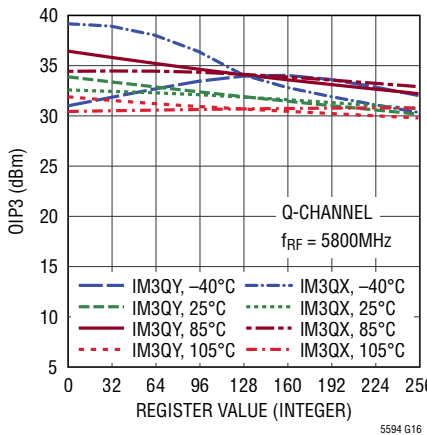

OIP3 vs IP3CC Register Value

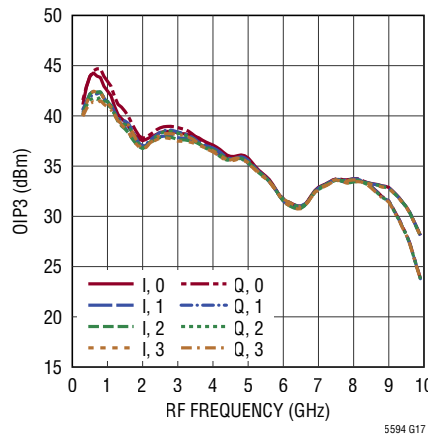

OIP3 vs IP3IC Register Value

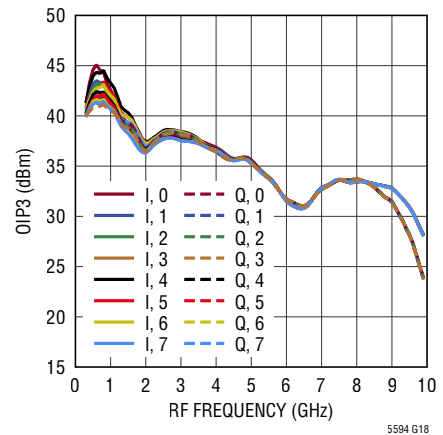

TYPICAL PERFORMANCE CHARACTERISTICS $V_{CC} = 5V$, $EN = 3.3V$, $T_C = 25^\circ C$, $P_{LO} = 6dBm$, $HSLO$, RF tone spacing = 4MHz, $f_{IF} = 30MHz$, $P_{IF} = -1.5dBm$ per tone, and register defaults. DC Blocks, 50Ω terminations, and MACOM H9 180° combiner at amplifier outputs de-embedded from measurement unless otherwise noted. Test circuit shown in Figure 1 with 1GHz interstage filter.

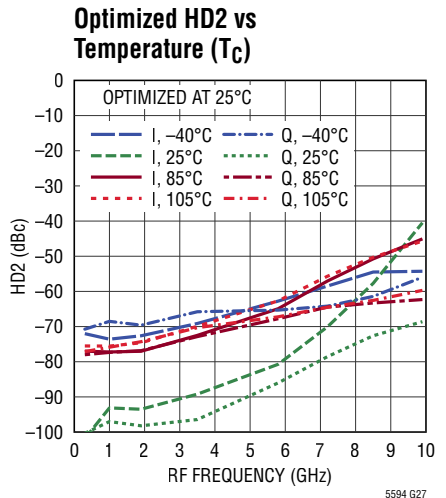
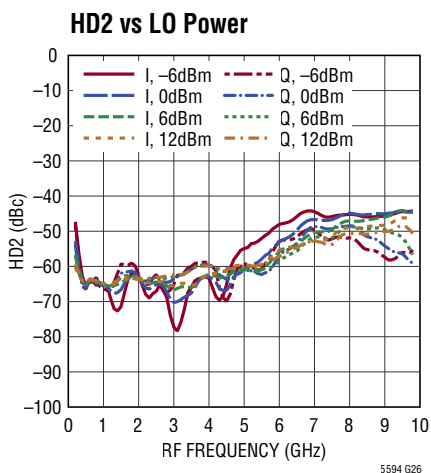
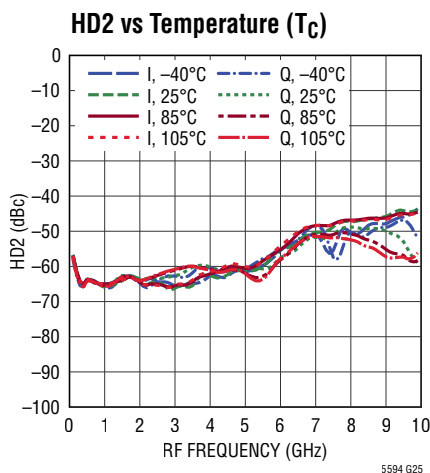
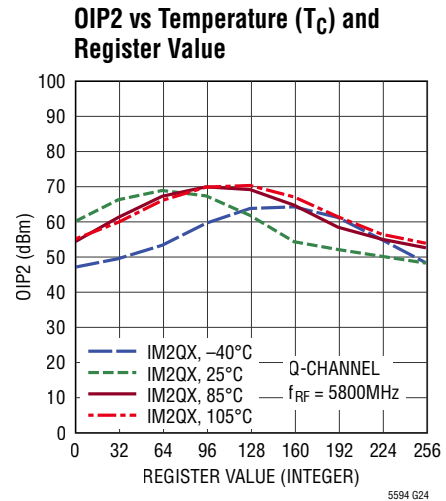
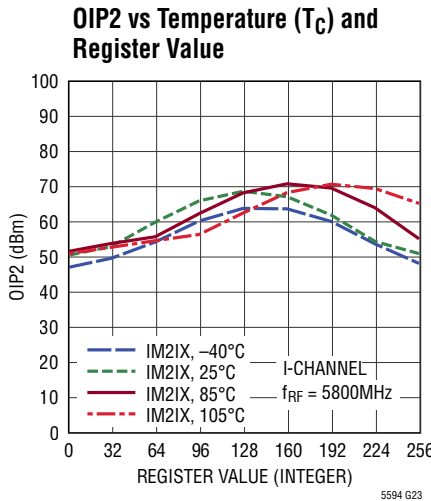
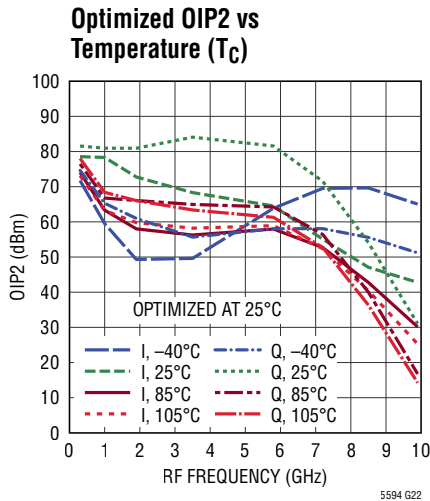
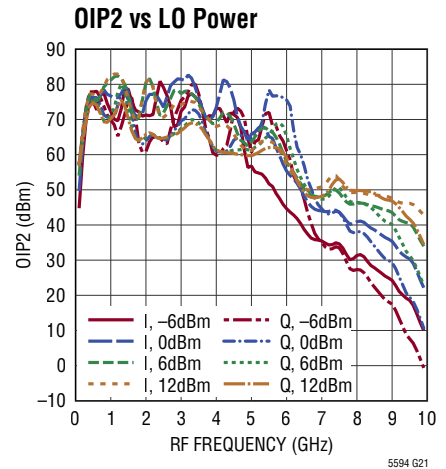
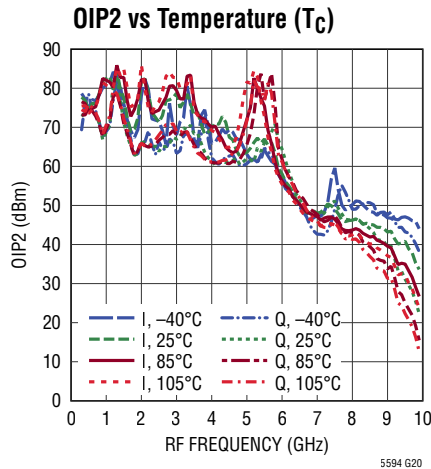
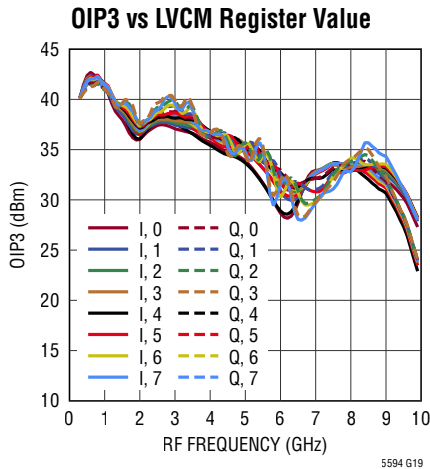

TYPICAL PERFORMANCE CHARACTERISTICS $V_{CC} = 5V$, $EN = 3.3V$, $T_C = 25^\circ C$, $P_{LO} = 6dBm$, $HSLO$, RF tone spacing = 4MHz, $f_{IF} = 30MHz$, $P_{IF} = -1.5dBm$ per tone, and register defaults. DC Blocks, 50Ω terminations, and MACOM H9 180° combiner at amplifier outputs de-embedded from measurement unless otherwise noted. Test circuit shown in Figure 1 with 1GHz interstage filter.

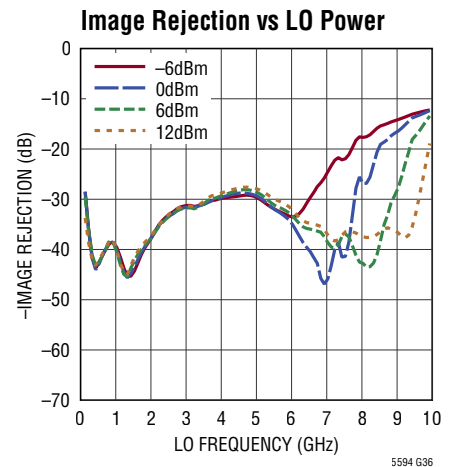
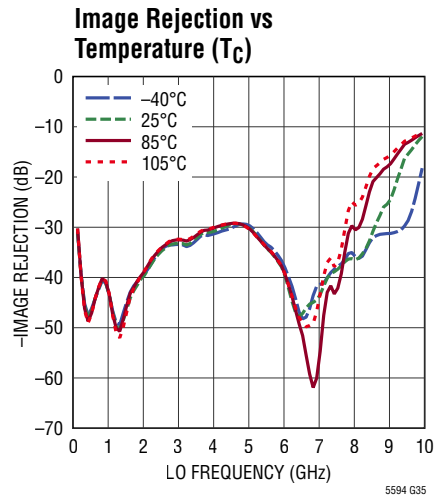
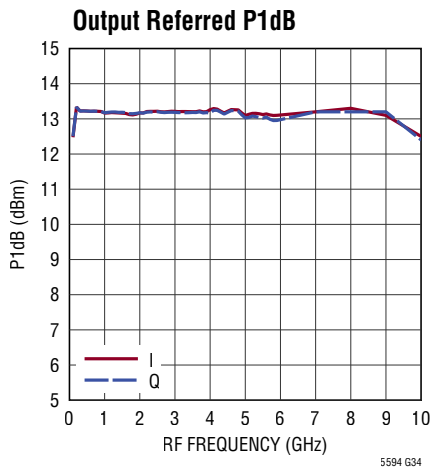
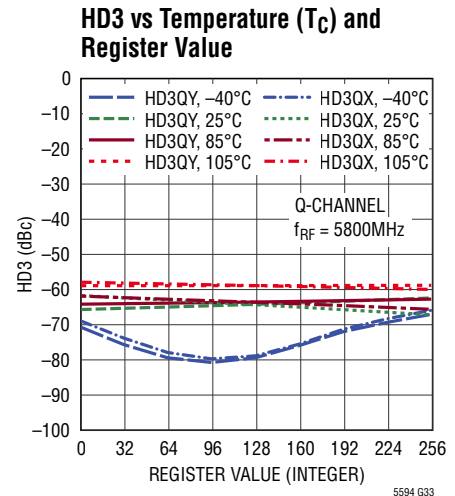
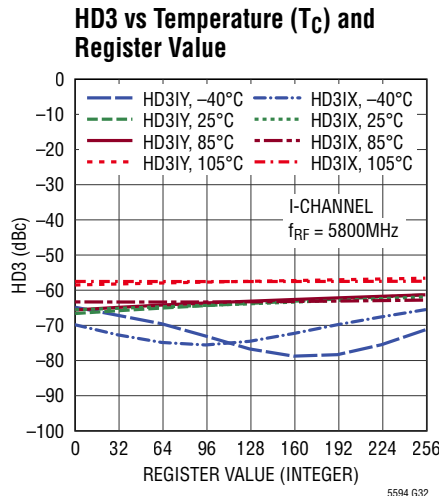
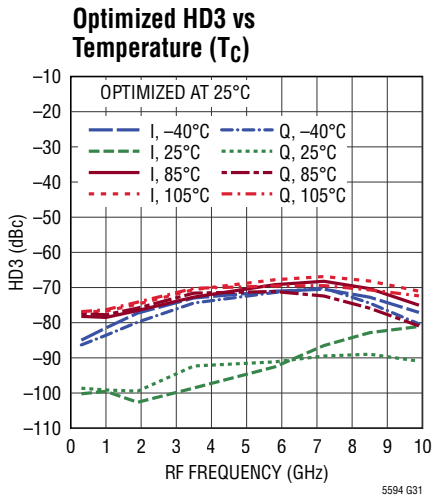
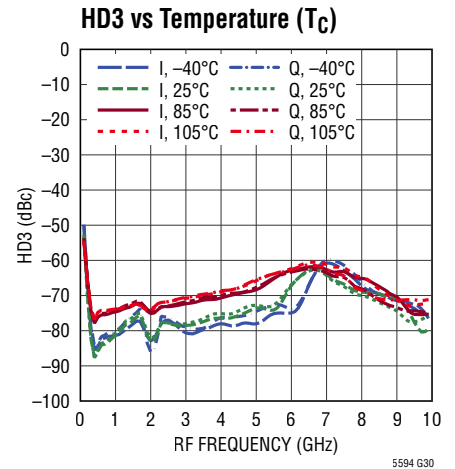
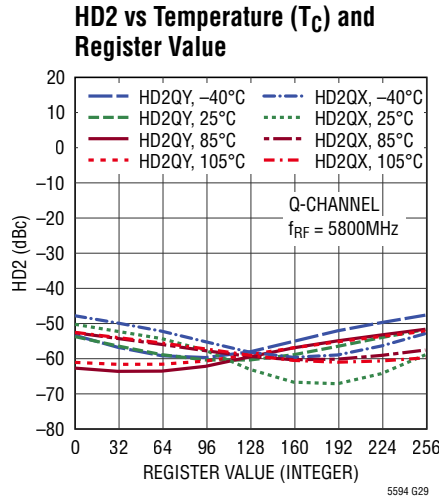
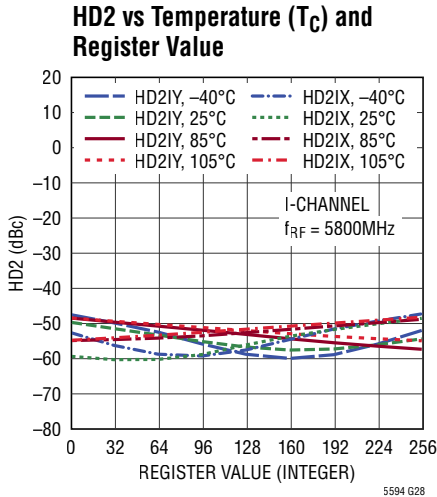

TYPICAL PERFORMANCE CHARACTERISTICS $V_{CC} = 5V$, $EN = 3.3V$, $T_C = 25^\circ C$, $P_{LO} = 6dBm$, $HSLO$, RF tone spacing = 4MHz, $f_{IF} = 30MHz$, $P_{IF} = -1.5dBm$ per tone, and register defaults. DC Blocks, 50Ω terminations, and MACOM H9 180° combiner at amplifier outputs de-embedded from measurement unless otherwise noted. Test circuit shown in Figure 1 with 1GHz interstage filter.

Optimized Image Rejection vs Temperature (T_C)

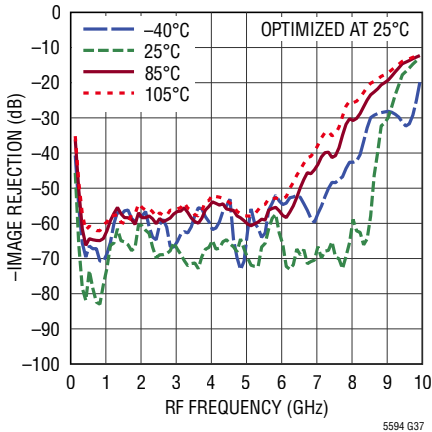

Optimized Image Rejection vs Baseband Frequency

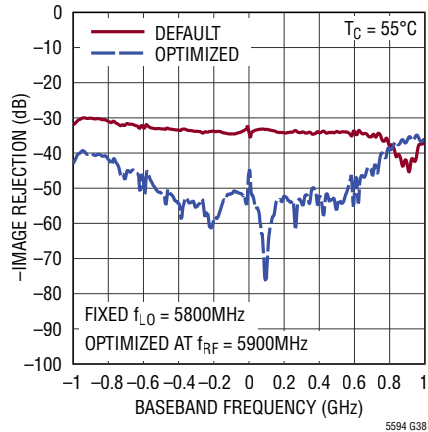

Gain Error vs Temperature (T_C) and GERR Register Value

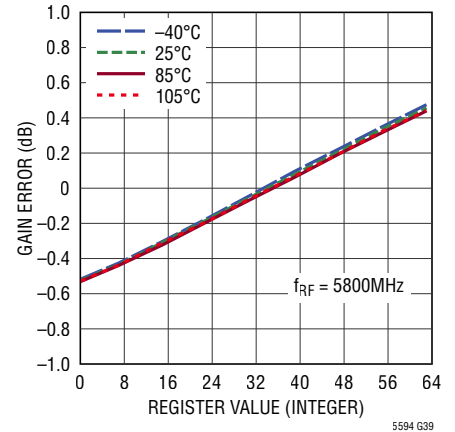

Phase Error vs Temperature (T_C) and PHA Register Value

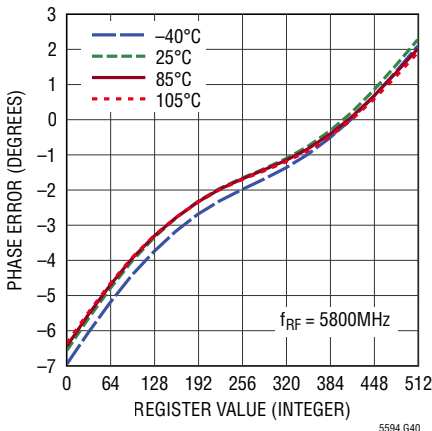

DC Offset vs Temperature (T_C)

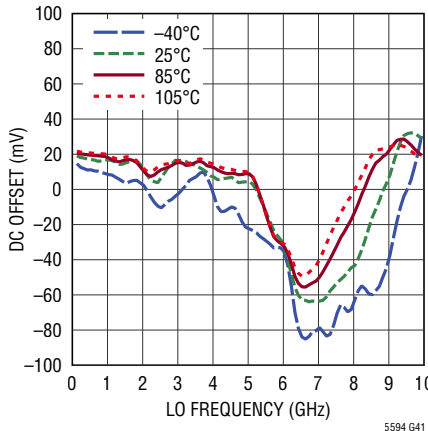

DC Offset vs LO Power

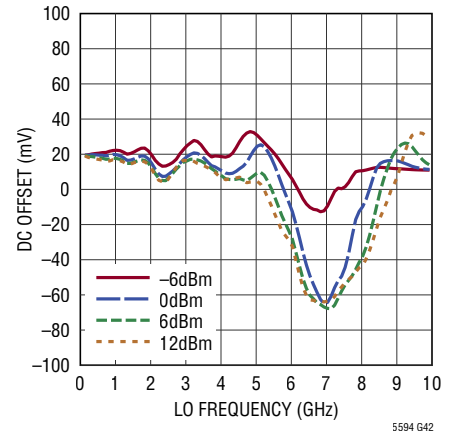

Optimized DC Offset vs Temperature (T_C)

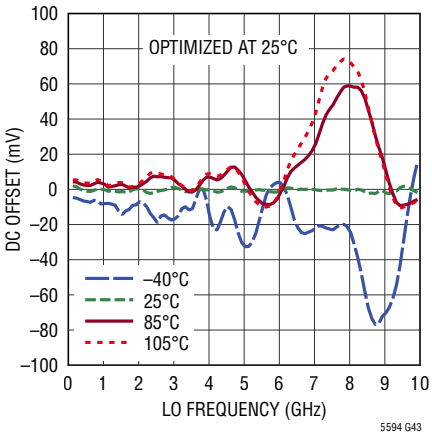

DC Offset vs Temperature (T_C) and Register Value

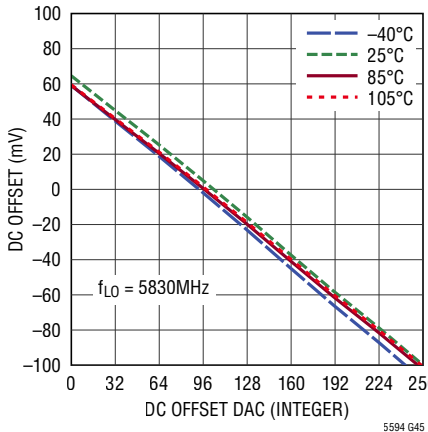

Blocking Noise Figure vs LO Power

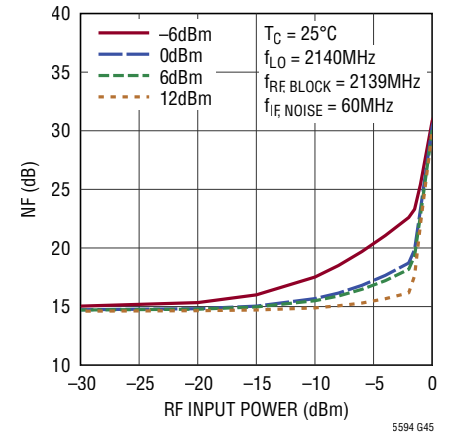

TYPICAL PERFORMANCE CHARACTERISTICS $V_{CC} = 5V$, $EN = 3.3V$, $T_C = 25^\circ C$, $P_{LO} = 6dBm$, $HSLO$, RF tone spacing = 4MHz, $f_{IF} = 30MHz$, $P_{IF} = -1.5dBm$ per tone, and register defaults. DC Blocks, 50Ω terminations, and MACOM H9 180° combiner at amplifier outputs de-embedded from measurement unless otherwise noted. Test circuit shown in Figure 1 with 1GHz interstage filter.

Gain, IIP3, and IIP2 for Mixer Only

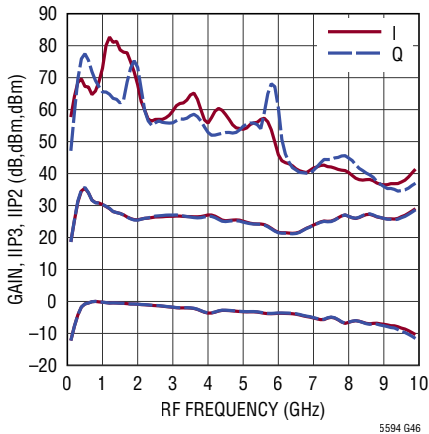

RF to LO Isolation

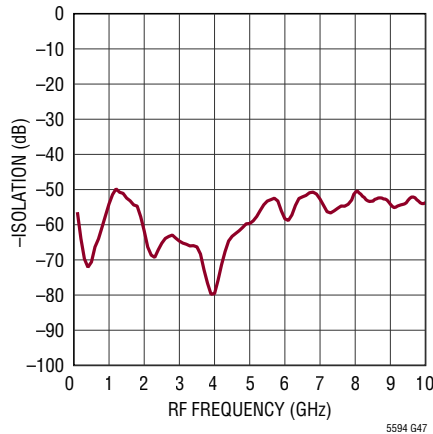

LO to RF Leakage

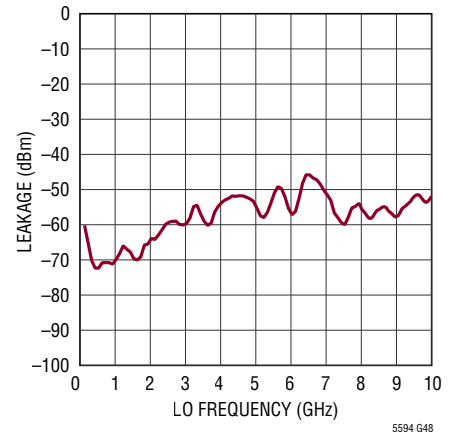

RF to IF Isolation

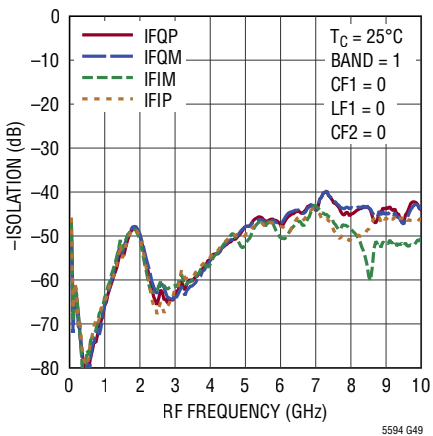

LO to IF Isolation

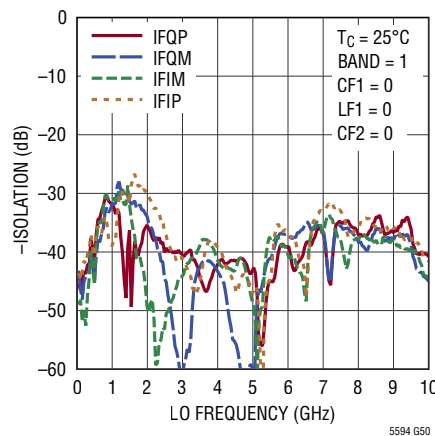

OIP3 Distribution vs Temperature (T_C)

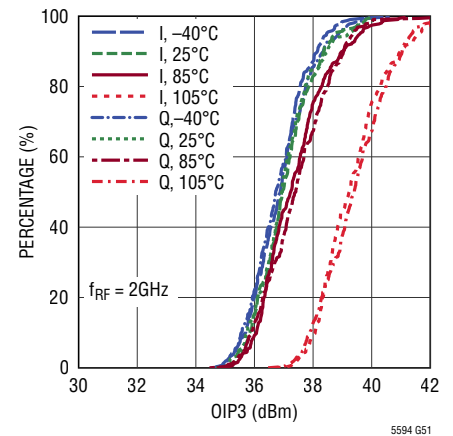

OIP2 Distribution vs Temperature (T_C)

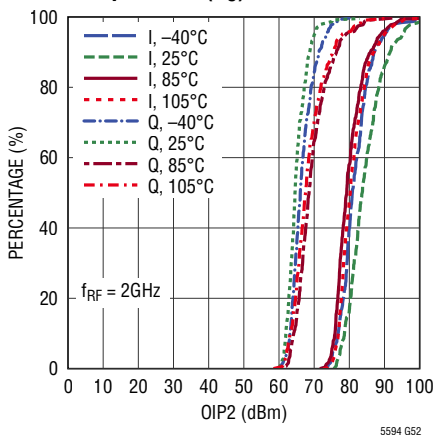

Conversion Gain Distribution vs Temperature (T_C)

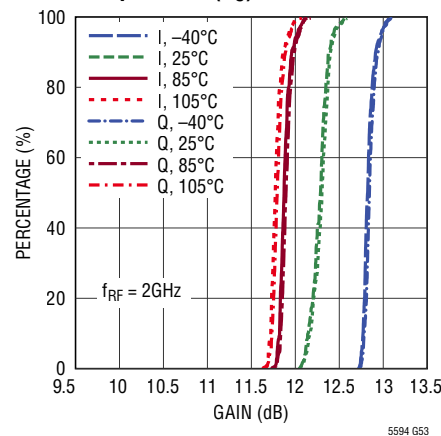

Noise Figure Distribution vs Temperature (T_C)

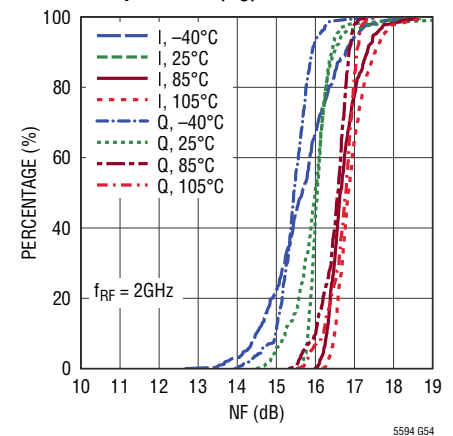

TYPICAL PERFORMANCE CHARACTERISTICS $V_{CC} = 5V$, $EN = 3.3V$, $T_C = 25^\circ C$, $P_{LO} = 6dBm$, $HSLO$, RF tone spacing = 4MHz, $f_{IF} = 30MHz$, $P_{IF} = -1.5dBm$ per tone, and register defaults. DC Blocks, 50 Ω terminations, and MACOM H9 180 $^\circ$ combiner at amplifier outputs de-embedded from measurement unless otherwise noted. Test circuit shown in Figure 1 with 1GHz interstage filter.

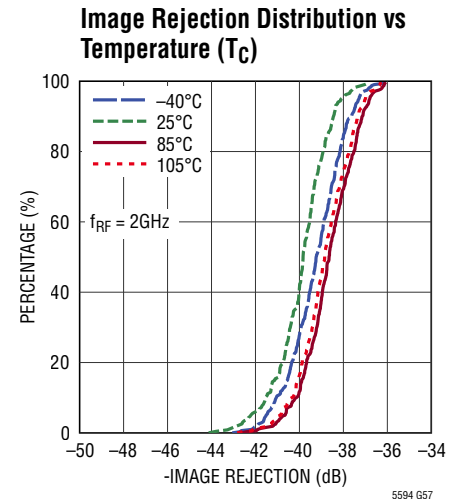
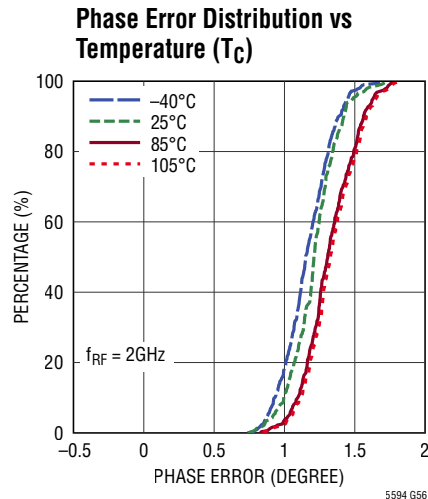
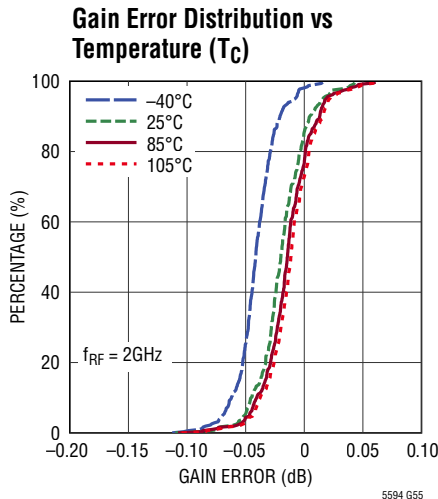

PIN FUNCTIONS

TEMP (Pin 2): Temperature Monitoring Diode. The diode to ground at this pin can be used to measure the die temperature. A forward bias current of 100 μA can be used into this pin and the forward voltage drop can be measured as a function of die temperature.

RF (Pin 4): 50 Ω RF Input. The pin should be DC-blocked with a coupling capacitor; 1000pF is recommended.

V_{CM} (Pin 6): IF Amplifier Common Mode Output Voltage Adjust. Source resistance should be 1k or lower. If this pin is left unconnected, it will internally self-bias to 0.9V.

EN (Pin 7): Enable Pin. A logic high on this pin will enable the chip. An internal 200k pull-down resistor ensures the chip remains disabled if there is no connection to the pin (open-circuit condition).

MQP, MQM, MIM, MIP (Pins 9, 10, 31, 32): Mixer Differential Output Pins. When connected to the amplifier input pins, the DC bias point is $V_{CC} - 1.4V$ for each pin. A lowpass filter is typically used between the MQM(P) or MIM(P) pins and the AQM(P) or AIM(P) pins to suppress the high frequency mixing products. See the Applications section for more information.

DNC (Pins 11, 14, 30): DO NOT CONNECT. No connection should be made to these pins.

AQM, AQP, AIP, AIM (Pins 12, 13, 28, 29): Amplifier Differential Input Pins. When connected to the mixer output pins, the DC bias point is $V_{CC} - 1.4V$ for each pin. A lowpass filter is typically used between the AQM(P) or AIM(P) pins and the MQM(P) or MIM(P) pins to suppress the high frequency mixing products. See the Applications section for more information.

IFQM, IFQP, IFIP, IFIM (Pins 15, 16, 25, 26): IF Amplifier Output Pins. The current used by the output amplifiers is set by a resistance of 25 Ω to 200 Ω from each pin to ground and the V_{CM} control voltage.

CSB (Pin 17): Chip Select Bar. When CSB is low, the serial interface is enabled. It can be driven with 1.2V to 3.3V logic levels.

V_{CC} (Pin 18): Positive Supply Pin. This pin should be bypassed with a 1000pF and 4.7 μF capacitor to ground.

LOP, LOM (Pins 19, 20): LO Inputs. External matching is not needed. Can be driven 50 Ω single-ended or 100 Ω differentially. The LO pins should be DC-blocked with

PIN FUNCTIONS

coupling capacitor; 1000pF is recommended. When driven single-ended, the unused pin should be terminated with 50Ω in series with the DC-blocking capacitor.

SDO (Pin 21): Serial Data Output. This output can accommodate logic levels from 1.2V to 3.3V. During read-mode, data is read out MSB first.

SDI (Pins 22): Serial Data Input. Data is clocked MSB first into the mode-control registers on the rising edge of SCK. SDI can be driven with 1.2V to 3.3V logic levels.

SCK (Pin 23): Serial Clock Input. SDI can be driven with 1.2V to 3.3V logic levels.

OV_{DD} (Pin 24): Positive Digital Interface Supply Pin. This pin sets the logic levels for the digital interface. 1.2V to 3.3V can be used. This pin should be bypassed with a 1μF

capacitor to ground. The V_{CC} supply must be applied before the OV_{DD} supply to prevent damage to the ESD diodes.

AMPD (Pin 27): IF Amplifier Disable Pin. A logic high on this pin will disable the IF amplifiers. The state of the IF amplifiers is the logical AND of $\overline{\text{AMPD}}$ and the EAMP register. An internal 200k pull-down resistor ensures the IF amplifiers are enabled by default if there is no connection to the pin (open-circuit condition).

GND (Pins 1, 3, 5, 8, Exposed Pad Pin 33): Ground. These pins must be soldered to the circuit board RF ground plane. The backside exposed pad ground connection should have a low inductance connection and good thermal contact to the printed circuit board ground plane using many through-hole vias. See layout information.

BLOCK DIAGRAM

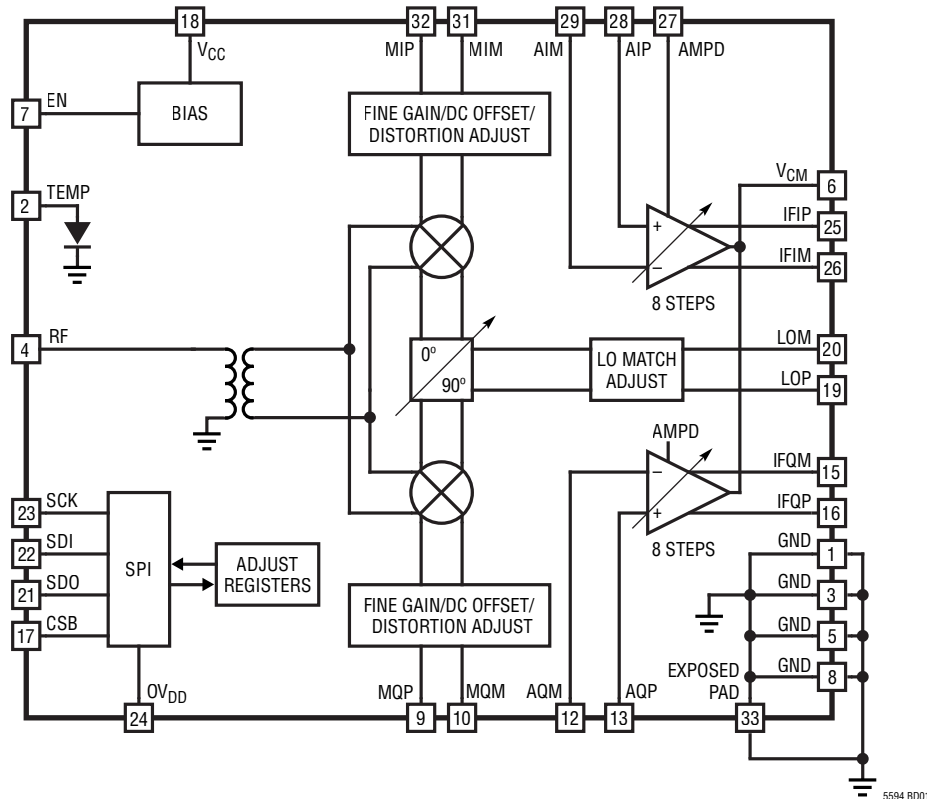

5594 BD01

TIMING DIAGRAMS

SPI Port Timing (Readback Mode)

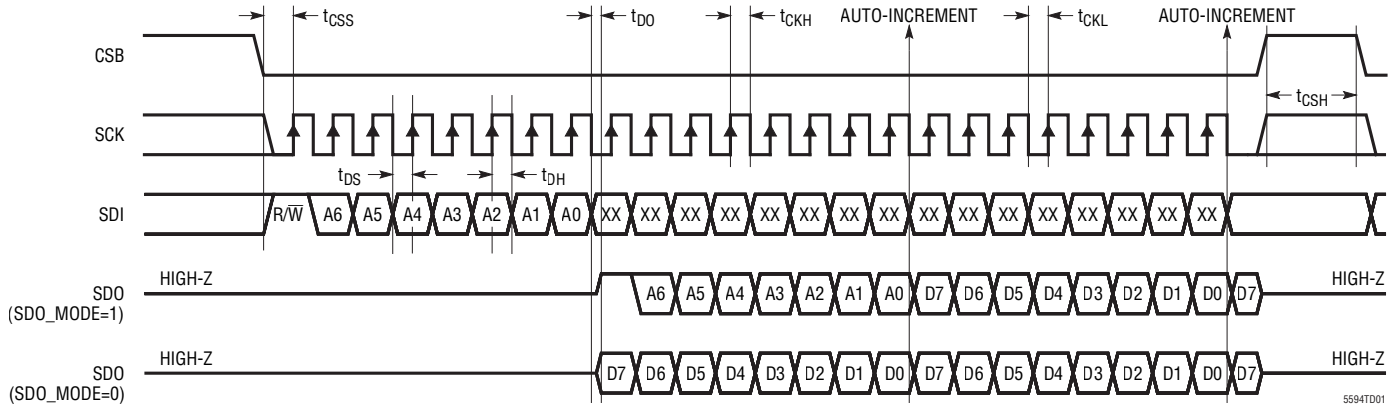

SPI Port Timing (Write Mode)

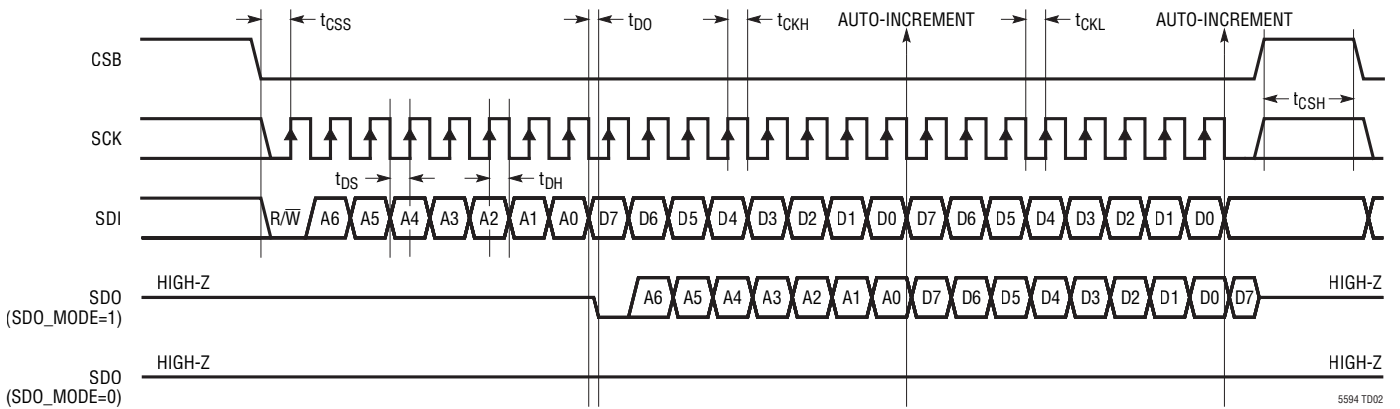

TEST CIRCUIT

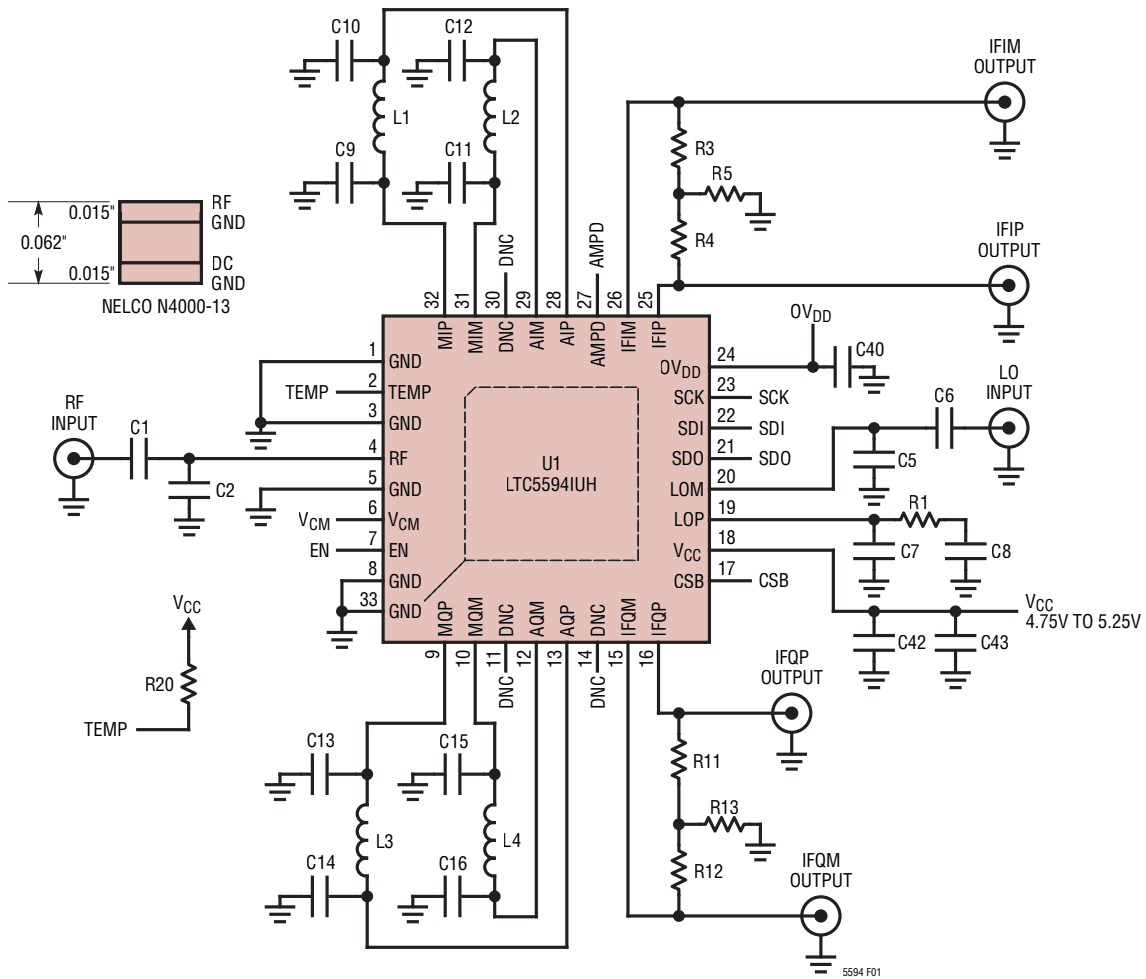

REF DES	VALUE	SIZE	VENDOR	REF DES	VALUE	SIZE	VENDOR
C1, C6, C8, C42	1000pF	0402	Murata	L1 TO L4	8.2nH	0805	Coilcraft
C2	0.2pF	0402	Murata	R1, R3, R4, R11, R12	49.9Ω	0402	
C5, C7	0.3pF	0402	Murata	R5, R13	0Ω	0402	
C9, C11, C13, C15	1.0pF	0201	Murata	R20	40.2kΩ	0402	
C10, C12, C14, C16	3.0pF	0201	Murata				
C40	1μF	0603	Murata				
C43	4.7μF	0805	Murata				

Figure 1. Test Circuit Schematic

TEST CIRCUIT

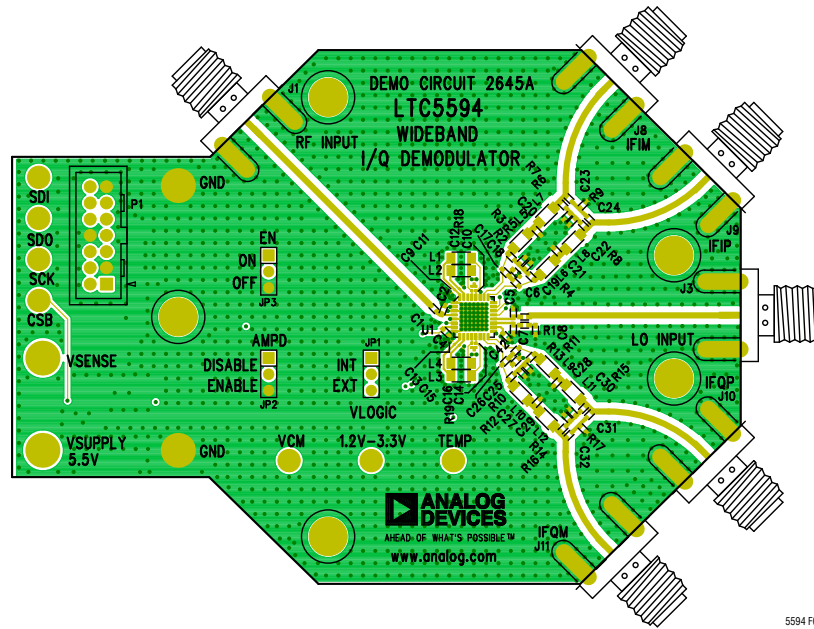

5594 F02

Figure 2. Component Side of Evaluation Board

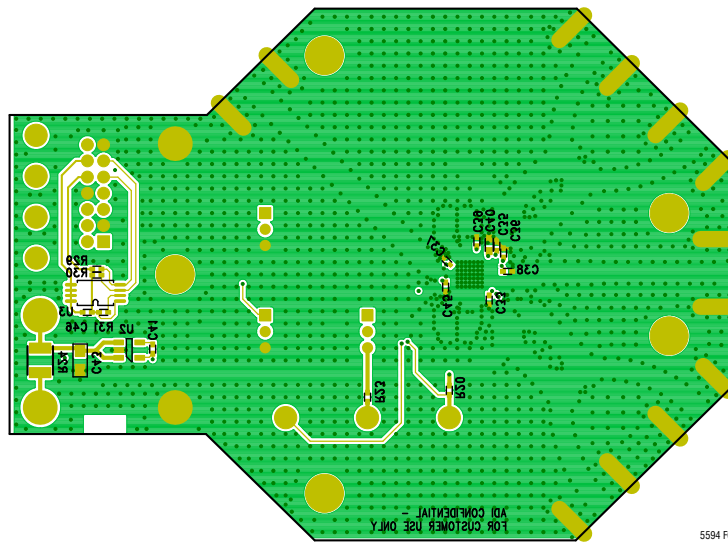

5594 F03

Figure 3. Bottom Side of Evaluation Board

APPLICATIONS INFORMATION

The LTC5594 is an IQ demodulator designed for high dynamic range receiver applications. It consists of an RF balun, I/Q mixers, quadrature LO amplifiers, IF amplifiers, and correction circuitry for DC offset, image rejection, and nonlinearity.

Operation

As shown in the Block Diagram for the LTC5594, the RF input signal is converted to a differential signal by the on-chip balun transformer before going to the I and Q channel mixers.

The LO inputs are impedance matched using a programmable network, and then accurately shifted in phase by 90° by an internal precision phase shifter. This phase shifter maintains the accurate quadrature relation over the full LO input range from 300MHz to 9GHz. In addition, the phase shifter allows fine tuning of the phase difference between the I- and Q-channel LO with a resolution of around 0.05 degrees to compensate for any phase mismatch between the mixers and phase mismatch introduced into the IF path by any filter component mismatch.

The differential mixer IF output signals are filtered off-chip to remove the $f_{RF} + f_{LO}$ signal and other high frequency mixing products before being applied to the on-chip IF amplifiers. The IF amplifiers have adjustable gain and common mode output voltage to allow for direct interfacing with A/D converters. The gain balance between both IF output channels of the LTC5594 can be fine tuned with a resolution of about 0.016dB in order to compensate for gain mismatches in the IF signal path, either caused

internally by the device or by external amplifiers and filters. The DC offset in both IF channels can be adjusted in order to minimize the accumulated DC offset at the A/D converter input.

The IF gain, gain error and phase error adjust, DC offset adjust, and nonlinearity adjust registers are digitally controlled through a 4-wire serial interface. The register map is detailed in the Appendix.

RF Input Port

Figure 4 shows a simplified schematic of the demodulator's RF input connected to an on-chip balun transformer. External DC voltage should not be applied to the RF input pin. DC current flowing into the pin may cause damage to the chip. Series DC blocking capacitors should be used to couple the RF input pin to the RF signal source. As shown in Figure 5, the RF input port is well matched with return loss greater than 10dB over the frequency range of 500MHz to 9GHz with a 0.2pF capacitor on C2. A 0.1pF capacitor on C3 placed 3mm away from C1 on the 50Ω input transmission line may improve return loss at higher frequencies. The RF pin can also be externally matched over the 300MHz to 500MHz frequency range by changing C2 to 6.8pF. Table 1 shows the impedance and input reflection coefficient for the RF input with $C2 = 0.2\text{pF}$. The input transmission line length is de-embedded from the measurement.

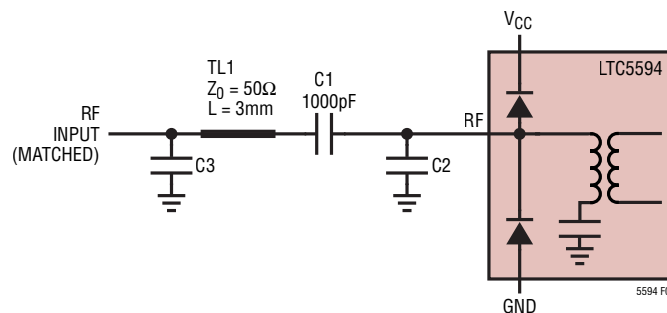

Figure 4. Simplified Schematic of the RF Input with External Matching Components

APPLICATIONS INFORMATION

Table 1. RF Input Impedance

FREQUENCY (MHz)	INPUT IMPEDANCE (Ω)	S11	
		MAG	ANGLE ($^{\circ}$)
300	30.0 + j57.1	0.594	122.5
1000	66.8 - j5.3	0.151	-17.6
1500	49.4 - j10.4	0.092	-94.0
2000	46.8 + j4.0	0.048	133.7
2500	48.9 + j12.8	0.113	96.0
3000	56.5 + j10.6	0.111	56.5
3500	62.7 - j5.8	0.124	-24.0
4000	61.5 - j23.6	0.233	-62.6
4500	55.4 - j30.6	0.278	-78.5
5000	47.0 - j26.3	0.236	-97.9
5500	38.6 - j16.1	0.191	-133.2
6000	33.7 - j7.5	0.206	-162.0
7000	32.3 - j12.0	0.240	-155.2
8000	33.9 + j0.1	0.192	179.7
9000	48.0 + j44.0	0.404	93.6

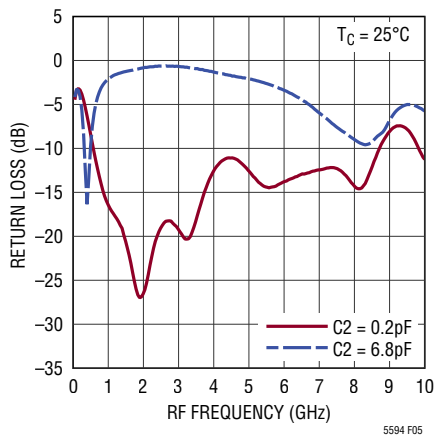

Figure 5. RF Input Return Loss with C2 = 0.2pF and 6.8pF

LO Input Port

The demodulator’s LO input interface is shown in Figure 6. The input consists of a programmable input match and a high precision quadrature phase shifter which generates 0° and 90° phase shifted LO signals for the LO buffer amplifiers to drive the I/Q mixers. DC blocking capacitors are required on the LOP and LOM inputs. When using a single-ended LO input, it is necessary to terminate the unused LO input (LOP in Figure 6) into 50 Ω .

The programmable input match adjust is controlled by the BAND, CF1, LF1, and CF2 registers as detailed in the register map shown in Table 2. The return loss for the register setting in Table 2 is shown in Figure 7.

Table 2. Register Settings for Single-Ended LO Matching

LO FREQUENCY (MHz)	BAND	CF1	LF1	CF2
300 to 339	0	31	3	31
339 to 398	0	21	3	24
398 to 419	0	14	3	23
419 to 556	0	17	2	31
556 to 625	0	10	2	23
625 to 801	0	15	1	31
801 to 831	0	14	1	27
831 to 1046	0	8	1	21
1046 to 1242	1	31	3	31
1242 to 1411	1	21	3	28
1411 to 1696	1	17	2	26
1696 to 2070	1	15	1	31
Default	1	8	3	3
2070 to 2470	1	8	1	21
2470 to 2980	1	2	1	10
2980 to 3500	1	1	0	19
3500 to 9000	1	0	0	0

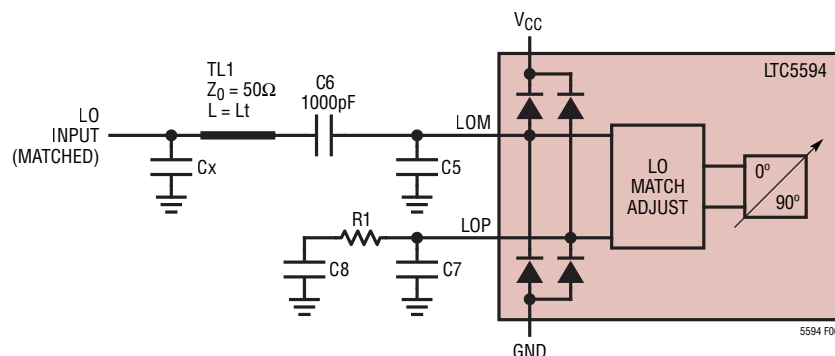

Figure 6. Simplified Schematic of the LO Inputs with Single-Ended Drive

APPLICATIONS INFORMATION

Figure 8 shows the high band LO input return loss for various input TL1 transmission line lengths for LO input frequencies from 6GHz to 9GHz. Return loss greater than 10dB can be achieved by using a 0.2pF capacitor at Cx on the input 50Ω transmission line. The high band LO input return loss is listed in Table 3 with no capacitor at Cx and BAND, CF1, LF1, and CF2 registers set to 1,0,0,0.

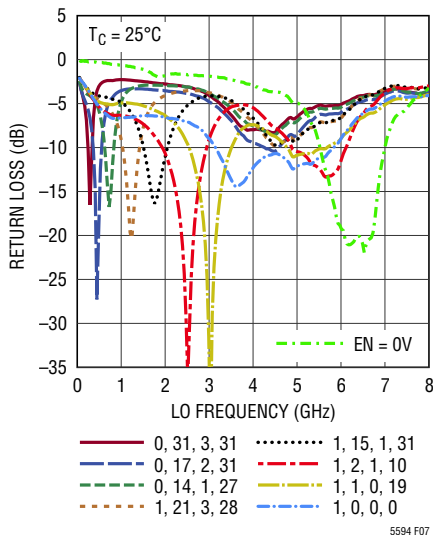

Figure 7. Single-Ended LO Input Return Loss vs BAND, CF1, LF1, and CF2

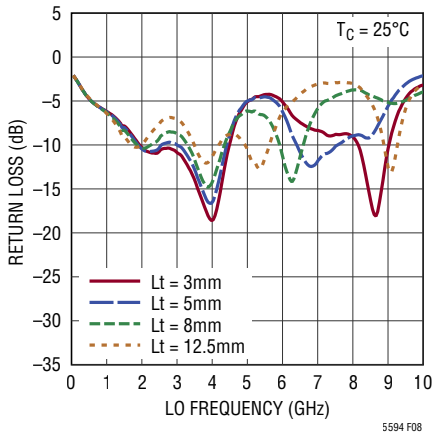

Figure 8. High Band LO Input Return Loss vs Input Transmission Line Length Lt

Table 3. High Band LO Input Impedance

FREQUENCY (MHz)	INPUT IMPEDANCE (Ω)	S11	
		MAG	ANGLE (°)
5000	87.2 + j37.9	0.436	46.4
5500	121.5 + j32.1	0.503	27.8
6000	132.1 + j5.4	0.453	4.8
6500	95.2 – j17.7	0.347	–23.8
7000	73.5 – j39.5	0.406	–58.2
7500	69.0 – j47.5	0.467	–66.0
8000	77.8 – j51.9	0.531	–59.9
8500	77.8 – j38.8	0.361	–75.4
9000	58.8 – j38.8	0.402	–122.6

Interstage Filter

An interstage IF filter should be used between the MIP (MIM) and AIP (AIM) pins and the MQP (MQM) and AQP (AQM) pins to suppress the large $f_{RF} + f_{LO}$ and other mixing products from the mixer outputs. Without the filter, the linearity of the amplifier can be degraded for the desired signal. Figure 9 shows a recommended lowpass filter. Table 4 shows typical values used for a lowpass response of various bandwidths.

Table 4. Component Values for Interstage Lowpass Filter

1dB BW (MHz)	L1, L2 (nH)	C9, C11 (pF)	C10, C12 (pF)
20	330	39	120
50	150	15	47
100	68	10	22
300	33	4.7	6.8
500	22	3.0	3.0
1000	8.2	1.0	3.0

It is important that the placement of C10 and C12 be as close as possible to the amplifier inputs. Long line lengths on the amplifier inputs can lead to instability. As shown in Figure 10, a 50Ω common mode termination resistance can be used to better ensure stability with long line lengths and/or higher order filtering. The placement of C9 and C11 should be as close as possible to the mixer outputs for effective filtering of the $2 \times f_{LO}$, $f_{RF} + f_{LO}$, and other mixing products.

By adjusting the values of the capacitors in the filter, it is possible to add or remove frequency slope of the IF response. The RF input has a frequency slope above 2GHz of approximately -1dB/GHz . If a high side LO (HSLO) is

APPLICATIONS INFORMATION

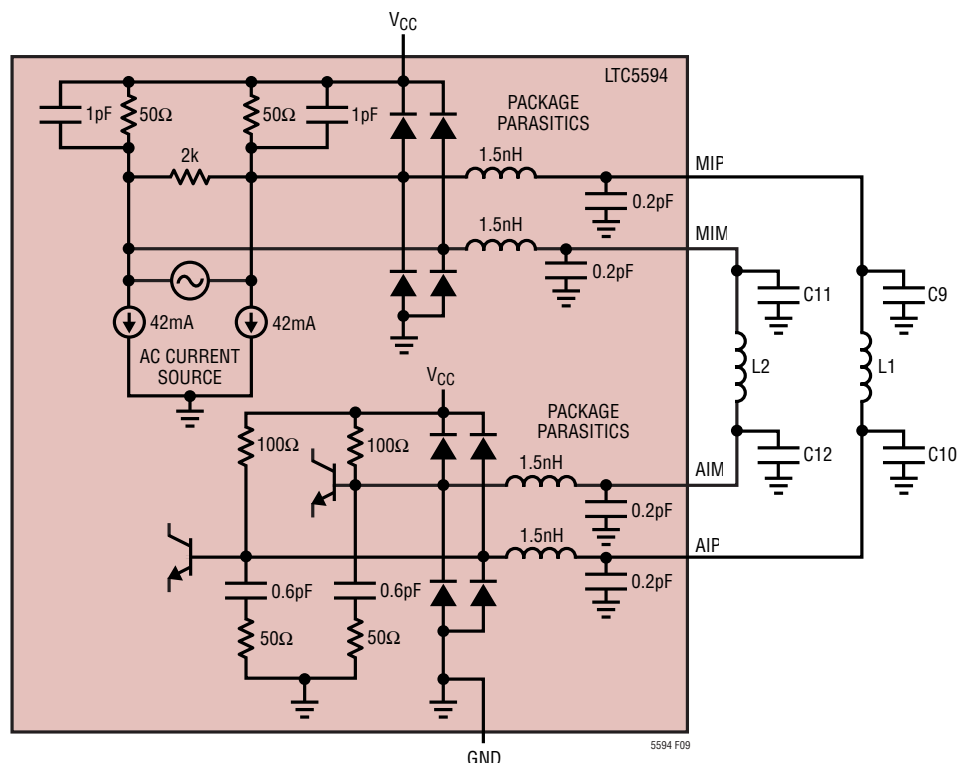

Figure 9. Simplified Schematic of the Mixer Output and IF Amplifier Input with Interstage Filter

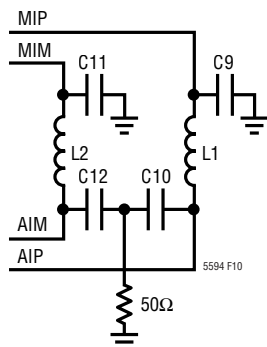

Figure 10. Interstage IF Filter with Common Mode Termination

used, the resulting IF slope will be 1dB/GHz. If a low side LO (LSLO) is used, the resulting IF slope will be $-1\text{dB}/\text{GHz}$. The IF filter component values can be adjusted so that approximately 1dB of peaking or roll-off can be achieved over the filter bandwidth to give an overall flat IF response for the HSLO or LSLO case.

I-Channel and Q-Channel Outputs

The phase relationship between the I-channel output signal and the Q-channel output signal is fixed. When the LO input frequency is higher (or lower) than the RF input frequency, the Q-channel outputs (IFQP, IFQM) lead (or lag) the I-channel outputs (IFIP, IFIM) by 90° .

Figure 11 shows a simplified schematic of the IF amplifier outputs. The current-mode outputs require a terminating resistance to establish a common mode voltage level. The optimum operating current is 18mA per output. A 50Ω termination is recommended on each output for a 0.9V common mode voltage (R5, R6). Operation at a higher common mode voltage is possible with the addition of a common mode termination. For example, to operate at 1.8V, an additional common mode resistance of 25Ω (R5 = 66.5Ω and R6 = 0Ω , or R5 = R6 = 43.2Ω) would be used to maintain an output current of 18mA. Alternatively, a 100Ω termination to ground on each output can be used for a 1.8V common mode voltage with 6dB more

APPLICATIONS INFORMATION

conversion gain. To operate at lower common mode voltages, a lower termination resistance can be used on each output at the expense of conversion gain, or a negative supply can be used at the connection of the termination resistors. Figure 12 shows the OIP3 of the amplifier alone with various common mode voltages.

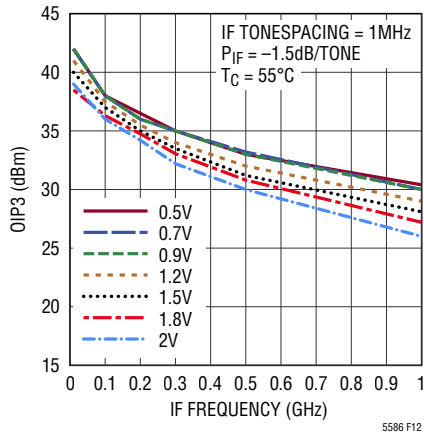

Figure 12. OIP3 of Amplifier Only vs Output Common Mode Voltage (V_{CM})

The amplifier gain can be adjusted in eight steps of roughly 1dB from 8dB to 15dB using the AMPG register. Setting AMPG = 0x7 sets the gain at about 15dB and setting AMPG = 0x0 sets the gain to about 8dB.

A typical anti-alias filter is shown in Figure 11 for interface with an ADC. The parallel combinations of R3||R7 and R4||R8 set the differential impedance for the ADC. The input and output of the filter contain a common mode termination for high frequencies. These are formed by C17, C18 and 24.9Ω at the input and C23, C24 and 24.9Ω at the output. The common mode termination at the amplifier output ensures stability and the common mode termination at the ADC input provides a termination for the high frequency kickback from the sampling capacitors in the ADC. Table 5 shows some typical values vs 1dB cutoff frequency for the anti-alias filter. To optimize the flatness and ripple of the IF band, both the IF interstage filter and the anti-alias filter can be designed together in a simulator including package parasitics. The additional slope due to RF slope and HSLO or LSLO can be compensated by using this method. The layout of the anti-alias filter should be done so that the amplifier outputs and ADC inputs are as close as possible. This is to prevent long line lengths from introducing additional parasitics.

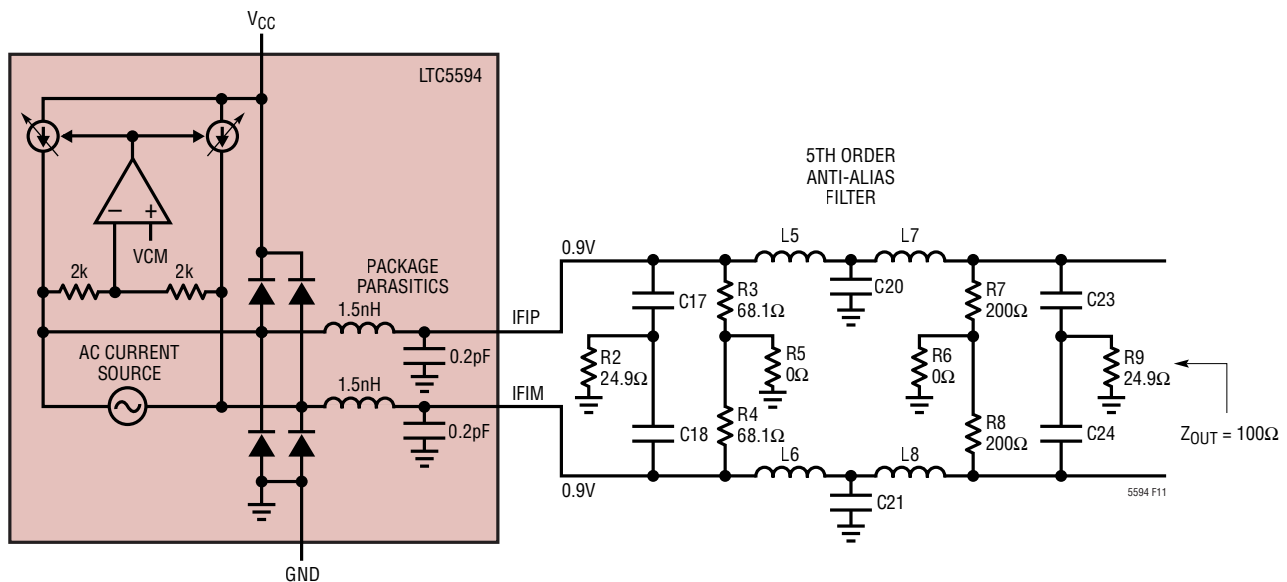

Figure 11. Simplified Schematic of the IF Amplifier Output with Anti-Alias Filter

APPLICATIONS INFORMATION

Table 5. Component Values for Anti-Alias Lowpass Filter

1dB BW (MHz)	L5 – L8 (nH)	C17, C18 (pF)	C20, C21 (pF)	C23, C24 (pF)
20	560	56	180	82
50	240	22	68	33
100	120	12	39	22
300	33	3.9	8.2	6.8
500	22	1.8	6.8	3.3
1000	8	1.0	3.3	1.8

Tables 6 and 7 show the differential and common mode S-parameters for the amplifier by itself with 50Ω terminations on all ports. In addition, common mode terminations were used on the input and output ports having a value of 2pF in series with 50Ω.

The common mode feedback amplifier holds the common mode output voltage within about 20mV of the V_{CM} pin voltage. The V_{CM} pin interface is shown in Figure 13. The V_{CM} pin should be driven by a voltage source with an output impedance lower than 1kΩ. When the V_{CM} pin is unbiased, the output common mode voltage will be held at a nominal 0.9V given by the internal voltage divider formed by the 40k and 8k resistors. Connecting the V_{CM} pin to an ADC common mode reference pin allows the output common mode voltage of the IF amplifier to track the ADC common mode.

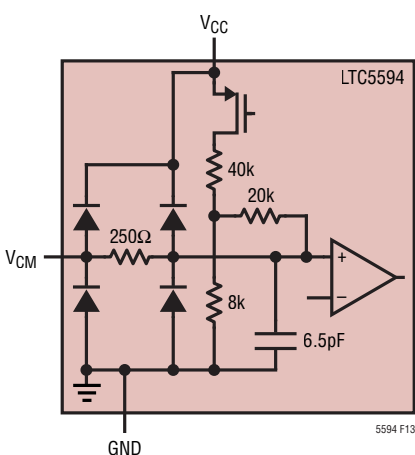

Figure 13. Simplified Schematic of the V_{CM} Input Pin

Table 6. IF Amplifier S-Parameters (Differential-Mode)

IF (MHz)	S_{11}		S_{21}		S_{12}		S_{22}	
	MAG	ANG	MAG	ANG	MAG	ANG	MAG	ANG
0.001	0.204	-179.9	2.129	180.0	1.8e-4	164.8	0.014	178.5
100	0.203	176.0	2.154	171.9	5.4e-4	118.0	0.026	-120.9
200	0.205	172.2	2.170	163.7	1.0e-4	102.8	0.050	-112.0
300	0.207	168.5	2.197	155.6	1.7e-4	92.8	0.079	-113.5
400	0.210	164.8	2.239	147.3	2.8e-4	93.7	0.111	-118.3
500	0.215	160.9	2.292	138.8	3.2e-4	95.4	0.147	-125.0
600	0.221	157.0	2.363	130.1	4.0e-4	92.0	0.186	-132.1
700	0.227	153.0	2.445	121.2	5.0e-4	92.1	0.230	-140.0
800	0.235	149.0	2.535	112.0	5.5e-4	86.2	0.279	-148.1
900	0.242	144.6	2.642	102.0	6.9e-4	93.2	0.334	-157.0
1000	0.251	140.6	2.770	92.3	7.9e-4	92.7	0.396	-166.2
1500	0.303	117.6	3.420	32.3	0.003	92.6	0.738	134.4
2000	0.365	90.2	3.318	-45.5	0.005	33.2	0.828	70.0
2500	0.385	56.1	2.232	-105.2	0.005	-3.1	0.666	13.1
3000	0.365	16.6	2.620	-160.2	0.005	-34.2	0.488	-38.4
3500	0.319	-28.2	1.021	157.4	0.005	-61.9	0.418	-94.7
4000	0.307	-83.4	0.742	113.3	0.005	-79.5	0.409	-150.6

Table 7. IF Amplifier S-Parameters (Common Mode)

IF (MHz)	S_{11}		S_{21}		S_{12}		S_{22}	
	MAG	ANG	MAG	ANG	MAG	ANG	MAG	ANG
0.001	0.184	-138.7	9.2e-4	-112.8	0.037	-65.3	0.985	179.8
100	0.186	172.5	0.085	-118.9	0.013	-68.6	0.152	126.7
200	0.188	166.6	0.173	-134.7	0.007	-91.8	0.125	116.7
300	0.191	160.2	0.237	-150.0	0.004	-113.1	0.097	97.3
400	0.196	154.4	0.291	-163.8	0.002	-145.4	0.067	75.2
500	0.202	148.4	0.340	-176.8	0.002	170.2	0.037	43.6
600	0.210	142.8	0.387	170.9	0.002	137.0	0.023	-38.0
700	0.219	137.2	0.436	159.1	0.003	118.1	0.051	-97.8
800	0.230	132.0	0.488	147.1	0.003	107.8	0.094	-121.5
900	0.243	126.5	0.550	134.9	0.004	106.6	0.148	-137.0
1000	0.252	120.9	0.612	122.2	0.006	104.8	0.211	-151.3
1500	0.325	96.7	0.981	43.4	0.020	80.4	0.749	136.1
2000	0.438	72.1	0.776	-46.1	0.036	18.6	1.005	55.9
2500	0.549	40.1	0.496	-97.1	0.041	-21.9	0.873	2.9
3000	0.601	6.9	0.397	-143.2	0.042	-52.2	0.764	-37.3
3500	0.618	-27.5	0.281	-175.7	0.044	-80.3	0.668	-72.7
4000	0.595	-60.3	0.254	147.3	0.046	-101.2	0.620	-107.0

APPLICATIONS INFORMATION

Temperature Diode

A schematic of the TEMP pin is shown in Figure 14. The temperature diode can be used to directly measure the die temperature. A 40k resistor is recommended to V_{CC} to generate a 100 μ A current source for the diode readout. The temperature slope is about $-1.52\text{mV}/^\circ\text{C}$.

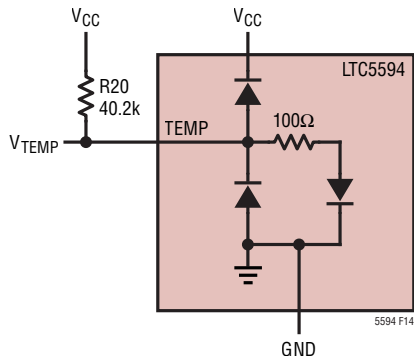

Figure 14. Schematic of the TEMP Pin

Enable Interface

A simplified schematic of the EN pin is shown in Figure 15. The enable voltage necessary to turn on the LTC5594 is $0.7 \cdot OV_{DD}$. To disable or turn off the chip, this voltage should be below $0.3 \cdot OV_{DD}$. If the EN pin is not connected, the chip is disabled. An internal 200k Ω pull-down keeps the part in shutdown mode if the pin is left floating. The LTC5594 can be put into a lower current sleep mode through the serial interface by writing 0x00 to register 0x16. This will dis-

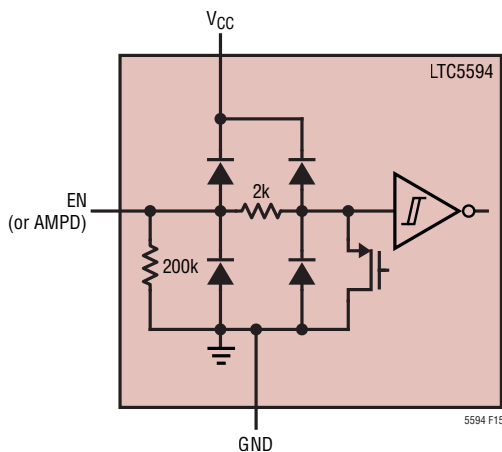

Figure 15. Simplified Schematic of the EN (or AMPD) Pin Interface

able the demodulator, amplifier, DC offset, and nonlinearity adjust circuits which are controlled by the EDEM, EAMP, EDC, and EADJ bits. Alternatively, writing any combination of bits to the four MSB's of register 0x16 will enable or disable the individual circuit blocks.

AMPD Interface

Also shown in Figure 15 is the simplified schematic for the AMPD IF amplifier disable pin. The IF amplifiers are enabled if the logical AND of AMPD and the EAMP register is 1. The IF amplifier state is detailed in Table 8.

Table 8. IF Amplifier State vs Logic Levels

EAMP Register	AMPD Pin	
	0	1
0	OFF	OFF
1	ON	OFF

Digital Input Pins

Figure 16 shows the simplified schematics for the digital input pins, SCK, CSB, and SDI. These pins should not be left floating, since there is no internal pull-down or pull-up.

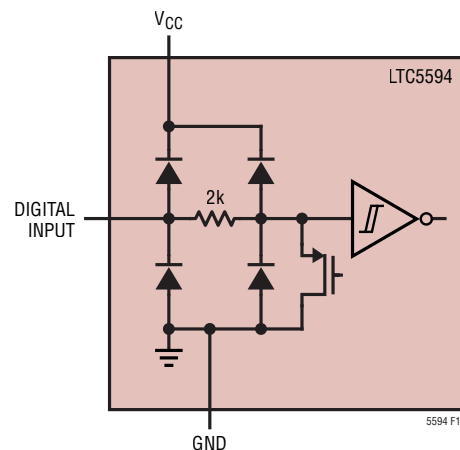

Figure 16. Simplified Schematic of the Digital Input Pins (SCK, CSB, SDI)

OV_{DD} Interface

Figure 17 shows the simplified schematic of the OV_{DD} interface. The OV_{DD} pin supplies the voltage for the digital inputs and SDO pin. By setting the pin at 1.2V to 3.3V, the serial port can function with 1.2V to 3.3V logic levels. It is important that when sequencing the supply voltages for

APPLICATIONS INFORMATION

the chip that the V_{CC} supply be brought up first before the OV_{DD} supply. This is to prevent the ESD diode connected between OV_{DD} and V_{CC} from getting damaged.

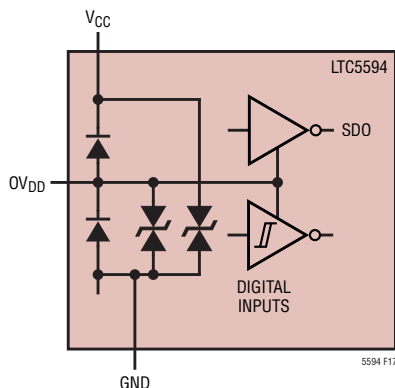

Figure 17. Simplified Schematic of the OV_{DD} Pin Interface

SERIAL PORT

The SPI compatible serial port provides control and monitoring functionality.

Communication Sequence

The serial bus is comprised of CSB, SCK, SDI and SDO. Data transfers to the part are accomplished by the serial bus master device first taking CSB low to enable the LTC5594's port. Input data applied on SDI is clocked on the rising edge of SCK, with all transfers MSB first. The communication burst is terminated by the serial bus master returning CSB high. See the timing diagrams for details.

Data is read from the part during a communication burst using SDO. Readback may be multidrop (more than one LTC5594 or other serial device connected in parallel on the serial bus), as SDO is high impedance (Hi-Z) when CSB = 1.

Single Byte Transfers

The serial port is arranged as a simple memory map, with status and control available in 23 registers as shown in the appendix. All data bursts are comprised of at least two 8-bit bytes. The most significant bit of the first byte is the read/write bit. Setting this bit to 1 puts the serial port into read mode. The next 7 bits of the first byte are address bits and can be set from 0x00 to 0x17. The subsequent byte, or bytes, is data from/to the specified register address. See the timing diagrams for details. Note that the written

data is transferred to the internal register at the falling edge of the 16th clock cycle (parallel load).

Multiple Byte Transfers

More efficient data transfer of multiple bytes is accomplished by using the LTC5594's register address auto-increment feature as shown in the timing diagram. The serial port master sends the destination register address in the first byte and reads or writes data in the second byte as before, but on the third byte the address pointer is auto-incremented by 1 and the serial port master can read or write to subsequent registers. If the register address pointer attempts to increment past 23 (0x17), it is automatically reset to 0.

SDO_MODE Control Bit

The SDO output has two modes of operation as shown in the timing diagram. When register 0x16 control bit SDO_MODE = 0, the SDO pin functions as a normal output which is Hi-Z during a write command. If SDO_MODE = 1, the SDO output is put into a serial repeater mode where SDO echos the command written to SDI before readback of register contents either in read or write mode. This can be used in high bus noise environments where it is necessary to perform error checking on commands sent to the serial port.

A simplified schematic of the SDO output is shown in Figure 18. The OV_{DD} supply sets the logic level of the output, and a 25 Ω series resistor limits the output current.

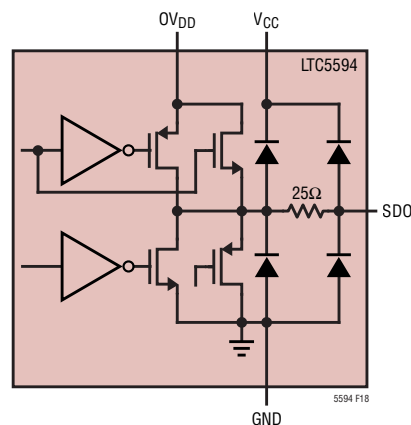

Figure 18. Simplified Schematic of the SDO Pin Interface

APPLICATIONS INFORMATION

Register Defaults

The register map and defaults are given in Tables 9 and 10 in the Appendix. When the device is powered up, the registers may not be reset to their default values. By writing a 1 to the SRST bit (bit[3]) of register 0x16, the device will go into soft reset and the registers will be reset to their default values.

Impairment Minimization

The LTC5594 contains circuitry for minimizing receiver impairments such as DC offset, phase and gain error, and nonlinearity. An example block diagram of a receiver

application is shown in Figure 19. A 2-tone source signal is applied to the RF input and the I and Q ADC outputs are measured in the digital domain to determine the optimized register settings in the LTC5594 for minimization of the impairments.

Figure 20 shows the nonoptimized baseband spectrum and Figure 21 shows the optimized baseband spectrum for a 2-tone test signal at 5.8GHz.

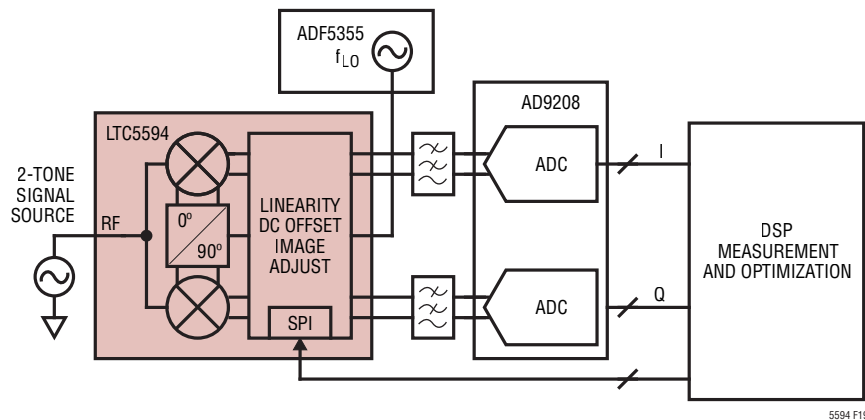

Figure 19. Example Block Diagram of a Receiver with 2-Tone Test Signal for Impairment Minimization

5594 F19

APPLICATIONS INFORMATION

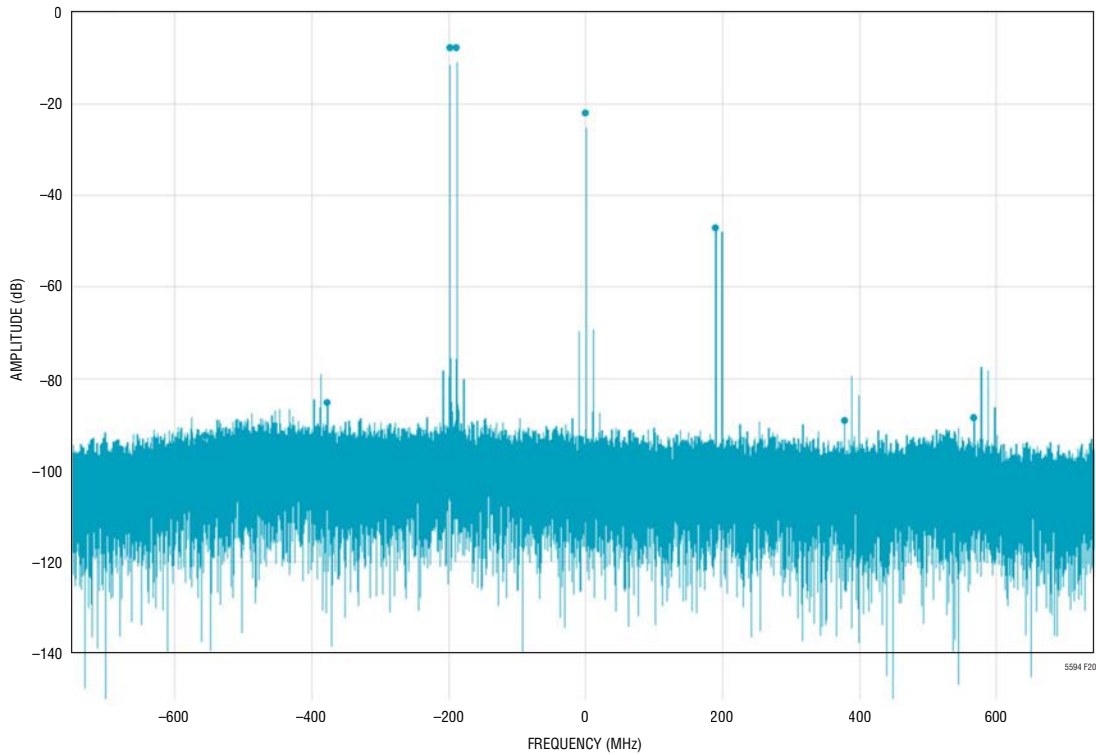

Figure 20. Nonoptimized 2-Tone Spectrum at 5.8GHz with 1GHz Anti-Alias Filter

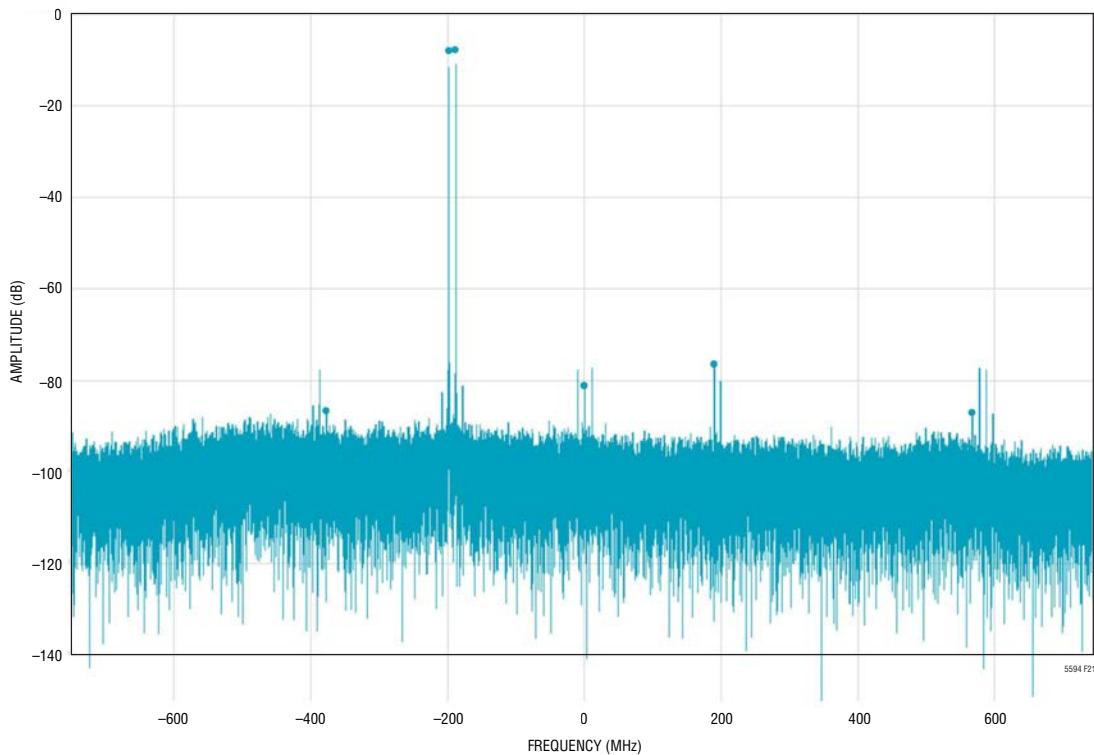

Figure 21. Optimized 2-Tone Spectrum at 5.8GHz with 1GHz Anti-Alias Filter

APPENDIX

Table 9. Serial Port Register Contents

ADDR	MSB	[6]	[5]	[4]	[3]	[2]	[1]	LSB	R/W	DEFAULT
0x00	IM3QY[7]	IM3QY[6]	IM3QY[5]	IM3QY[4]	IM3QY[3]	IM3QY[2]	IM3QY[1]	IM3QY[0]	R/W	0x80
0x01	IM3QX[7]	IM3QX[6]	IM3QX[5]	IM3QX[4]	IM3QX[3]	IM3QX[2]	IM3QX[1]	IM3QX[0]	R/W	0x80
0x02	IM3IY[7]	IM3IY[6]	IM3IY[5]	IM3IY[4]	IM3IY[3]	IM3IY[2]	IM3IY[1]	IM3IY[0]	R/W	0x80
0x03	IM3IX[7]	IM3IX[6]	IM3IX[5]	IM3IX[4]	IM3IX[3]	IM3IX[2]	IM3IX[1]	IM3IX[0]	R/W	0x80
0x04	IM2QX[7]	IM2QX[6]	IM2QX[5]	IM2QX[4]	IM2QX[3]	IM2QX[2]	IM2QX[1]	IM2QX[0]	R/W	0x80
0x05	IM2IX[7]	IM2IX[6]	IM2IX[5]	IM2IX[4]	IM2IX[3]	IM2IX[2]	IM2IX[1]	IM2IX[0]	R/W	0x80
0x06	HD3QY[7]	HD3QY[6]	HD3QY[5]	HD3QY[4]	HD3QY[3]	HD3QY[2]	HD3QY[1]	HD3QY[0]	R/W	0x80
0x07	HD3QX[7]	HD3QX[6]	HD3QX[5]	HD3QX[4]	HD3QX[3]	HD3QX[2]	HD3QX[1]	HD3QX[0]	R/W	0x80
0x08	HD3IY[7]	HD3IY[6]	HD3IY[5]	HD3IY[4]	HD3IY[3]	HD3IY[2]	HD3IY[1]	HD3IY[0]	R/W	0x80
0x09	HD3IX[7]	HD3IX[6]	HD3IX[5]	HD3IX[4]	HD3IX[3]	HD3IX[2]	HD3IX[1]	HD3IX[0]	R/W	0x80
0x0A	HD2QY[7]	HD2QY[6]	HD2QY[5]	HD2QY[4]	HD2QY[3]	HD2QY[2]	HD2QY[1]	HD2QY[0]	R/W	0x80
0x0B	HD2QX[7]	HD2QX[6]	HD2QX[5]	HD2QX[4]	HD2QX[3]	HD2QX[2]	HD2QX[1]	HD2QX[0]	R/W	0x80
0x0C	HD2IY[7]	HD2IY[6]	HD2IY[5]	HD2IY[4]	HD2IY[3]	HD2IY[2]	HD2IY[1]	HD2IY[0]	R/W	0x80
0x0D	HD2IX[7]	HD2IX[6]	HD2IX[5]	HD2IX[4]	HD2IX[3]	HD2IX[2]	HD2IX[1]	HD2IX[0]	R/W	0x80
0x0E	DCOI[7]	DCOI[6]	DCOI[5]	DCOI[4]	DCOI[3]	DCOI[2]	DCOI[1]	DCOI[0]	R/W	0x80
0x0F	DCOQ[7]	DCOQ[6]	DCOQ[5]	DCOQ[4]	DCOQ[3]	DCOQ[2]	DCOQ[1]	DCOQ[0]	R/W	0x80
0x10	0*	0*	0*	0*	0*	IP3IC[2]	IP3IC[1]	IP3IC[0]	R/W	0x04
0x11	GERR[5]	GERR[4]	GERR[3]	GERR[2]	GERR[1]	GERR[0]	IP3CC[1]	IP3CC[0]	R/W	0x82
0x12	LVCM[2]	LVCM[1]	LVCM[0]	CF1[4]	CF1[3]	CF1[2]	CF1[1]	CF1[0]	R/W	0x48
0x13	BAND	LF1[1]	LF1[0]	CF2[4]	CF2[3]	CF2[2]	CF2[1]	CF2[0]	R/W	0xE3
0x14	PHA[8]	PHA[7]	PHA[6]	PHA[5]	PHA[4]	PHA[3]	PHA[2]	PHA[1]	R/W	0x80
0x15	PHA[0]	AMPG[2]	AMPG[1]	AMPG[0]	AMPCC[1]	AMPCC[0]	AMPIC[1]	AMPIC[0]	R/W	0x6A
0x16	EDEM	EDC	EADJ	EAMP	SRST	SDO_MODE	0*	0*	R/W	0xF0
0x17	CHIPID[1]	CHIPID[0]	0*	0*	0*	0*	0*	1*	R/W	0x01

*Unused, do not change default value.

APPENDIX

Table 10. Serial Port Register Bit Field Summary

BITS	FUNCTION	DESCRIPTION	VALID VALUES	DEFAULT
AMPCC[1:0]	IF Amplifier IM3 CC Adjust	Used to optimize the IF amplifier IM3.	0x00 to 0x03	0x02
AMPIC[1:0]	IF Amplifier IM3 IC Adjust	Used to optimize the IF amplifier IM3.	0x00 to 0x03	0x02
AMPG[2:0]	IF Amplifier Gain Adjust	Adjusts the amplifier gain from 8dB to 15dB.	0x00 to 0x07	0x06
BAND	LO Band Select	Selects which LO matching band is used. BAND = 1 for high band. BAND = 0 for low band.	0, 1	1
CF1[5:0]	LO Matching Capacitor CF1	Controls the CF1 capacitor in the LO matching network.	0x00 to 0x1F	0x08
CF2[5:0]	LO Matching Capacitor CF2	Controls the CF2 capacitor in the LO matching network.	0x00 to 0x1F	0x03
CHIPID	Chip Identification Bits	Factory set to default value.	0x00 to 0x03	0x00
DCOI[7:0]	I-Channel DC Offset	Controls the I-channel DC offset over a range from -200mV to 200mV.	0x00 to 0xFF	0x80
DCOQ[7:0]	Q-Channel DC Offset	Controls the Q-channel DC offset over a range from -200mV to 200mV.	0x00 to 0xFF	0x80
EADJ	Enable Nonlinearity Adjust	Enables the nonlinearity adjustment circuitry if EADJ = 1.	0, 1	1
EAMP	Enable IF Amplifiers	Enables the IF amplifiers if EAMP = 1.	0, 1	1
EDC	Enable DC Offset Adjust	Enables the DC offset adjustment circuitry if EDC = 1.	0, 1	1
EDEM	Enable Demodulator	Enables the demodulator circuitry if EDEM = 1.	0, 1	1
GERR[5:0]	I _Q Gain Error Adjust	Controls the I _Q gain error over a range from -0.5dB to 0.5dB.	0x00 to 0x3F	0x20
HD2IX[7:0]	HD2 I-Channel X-Vector	Controls the I-channel HD2 X-vector adjustment if EADJ = 1.	0x00 to 0xFF	0x80
HD2IY[7:0]	HD2 I-Channel Y-Vector	Controls the I-channel HD2 Y-vector adjustment if EADJ = 1.	0x00 to 0xFF	0x80
HD2QX[7:0]	HD2 Q-Channel X-Vector	Controls the Q-channel HD2 X-vector adjustment if EADJ = 1.	0x00 to 0xFF	0x80
HD2QY[7:0]	HD2 Q-Channel Y-Vector	Controls the Q-channel HD2 Y-vector adjustment if EADJ = 1.	0x00 to 0xFF	0x80
HD3IX[7:0]	HD3 I-Channel X-Vector	Controls the I-channel HD3 X-vector adjustment if EADJ = 1.	0x00 to 0xFF	0x80
HD3IY[7:0]	HD3 I-Channel Y-Vector	Controls the I-channel HD3 Y-vector adjustment if EADJ = 1.	0x00 to 0xFF	0x80
HD3QX[7:0]	HD3 Q-Channel X-Vector	Controls the Q-channel HD3 X-vector adjustment if EADJ = 1.	0x00 to 0xFF	0x80
HD3QY[7:0]	HD3 Q-Channel Y-Vector	Controls the Q-channel HD3 Y-vector adjustment if EADJ = 1.	0x00 to 0xFF	0x80
IM2IX[7:0]	IM2 I-Channel X-Vector	Controls the I-channel IM2 X-vector adjustment if EADJ = 1.	0x00 to 0xFF	0x80
IM2QX[7:0]	IM2 Q-Channel X-Vector	Controls the Q-channel IM2 X-vector adjustment if EADJ = 1.	0x00 to 0xFF	0x80
IM3IX[7:0]	IM3 I-Channel X-Vector	Controls the I-channel IM3 X-vector adjustment if EADJ = 1.	0x00 to 0xFF	0x80
IM3IY[7:0]	IM3 I-Channel Y-Vector	Controls the I-channel IM3 Y-vector adjustment if EADJ = 1.	0x00 to 0xFF	0x80
IM3QX[7:0]	IM3 Q-Channel X-Vector	Controls the Q-channel IM3 X-vector adjustment if EADJ = 1.	0x00 to 0xFF	0x80
IM3QY[7:0]	IM3 Q-Channel Y-Vector	Controls the Q-channel IM3 Y-vector adjustment if EADJ = 1.	0x00 to 0xFF	0x80
IP3CC[1:0]	RF Input IP3 CC Adjust	Used to optimize the RF input IP3.	0x00 to 0x03	0x02
IP3IC[2:0]	RF Input IP3 IC Adjust	Used to optimize the RF input IP3.	0x00 to 0x07	0x04
LF1[1:0]	LO Matching Inductor LF1	Controls the LF1 inductor in the LO matching network.	0x00 to 0x03	0x03
LVCM[2:0]	LO Bias Adjust	Used to optimize mixer IP3.	0x00 to 0x07	0x02
PHA[8:0]	I _Q Phase Error Adjust	Controls the I _Q phase error over a range from -2.5 Degrees to 2.5 Degrees.	0x000 to 0x1FF	0x100
SDO_MODE	SDO Readback Mode	Enables the SDO readback mode if SDO_MODE = 1.	0, 1	0
SRST	Soft Reset	Writing 1 to this bit resets all registers to their default values.	0, 1	0

PACKAGE DESCRIPTION

UH Package
32-Lead Plastic QFN (5mm × 5mm)
 (Reference LTC DWG # 05-08-1693 Rev D)

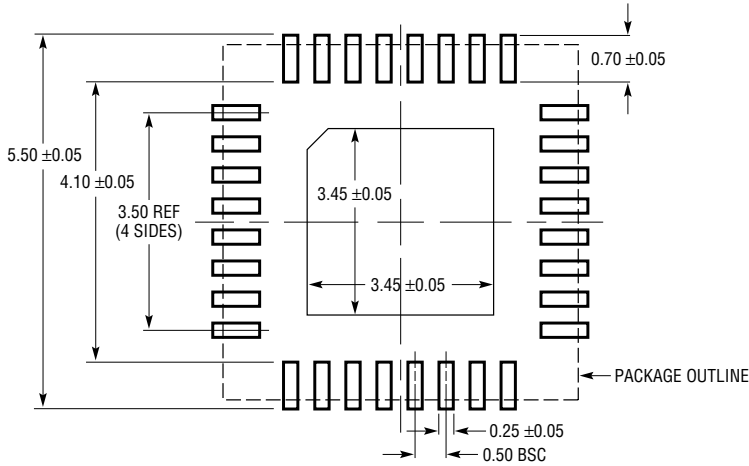

RECOMMENDED SOLDER PAD LAYOUT
 APPLY SOLDER MASK TO AREAS THAT ARE NOT SOLDERED

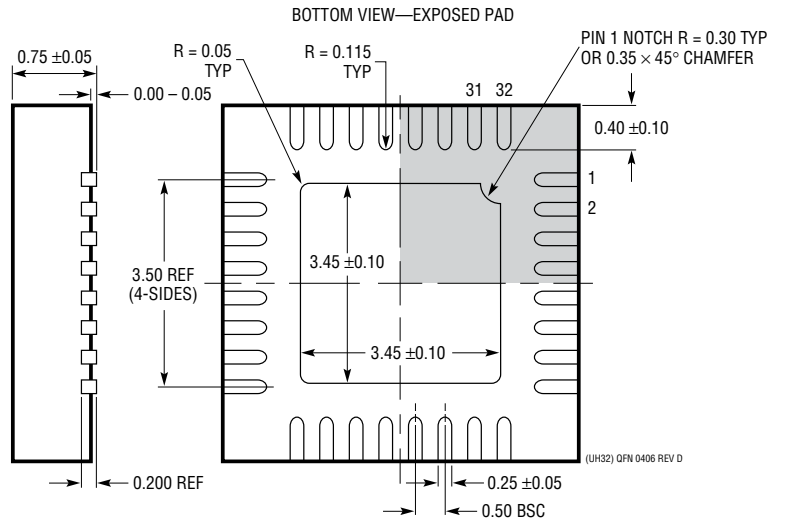
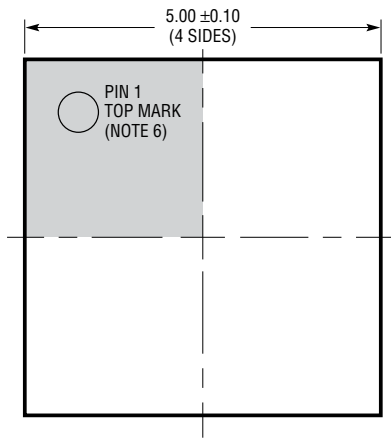

- NOTE:
1. DRAWING PROPOSED TO BE A JEDEC PACKAGE OUTLINE MO-220 VARIATION WHHD-(X) (TO BE APPROVED)
 2. DRAWING NOT TO SCALE
 3. ALL DIMENSIONS ARE IN MILLIMETERS
 4. DIMENSIONS OF EXPOSED PAD ON BOTTOM OF PACKAGE DO NOT INCLUDE MOLD FLASH. MOLD FLASH, IF PRESENT, SHALL NOT EXCEED 0.20mm ON ANY SIDE
 5. EXPOSED PAD SHALL BE SOLDER PLATED
 6. SHADED AREA IS ONLY A REFERENCE FOR PIN 1 LOCATION ON THE TOP AND BOTTOM OF PACKAGE

REVISION HISTORY

REV	DATE	DESCRIPTION	PAGE NUMBER
A	06/18	Added $T_J = 25^\circ\text{C}$	5, 7

TYPICAL APPLICATION

Simplified Schematic of a 0.5GHz to 9.0GHz Receiver, (Only I-Channel Is Shown)

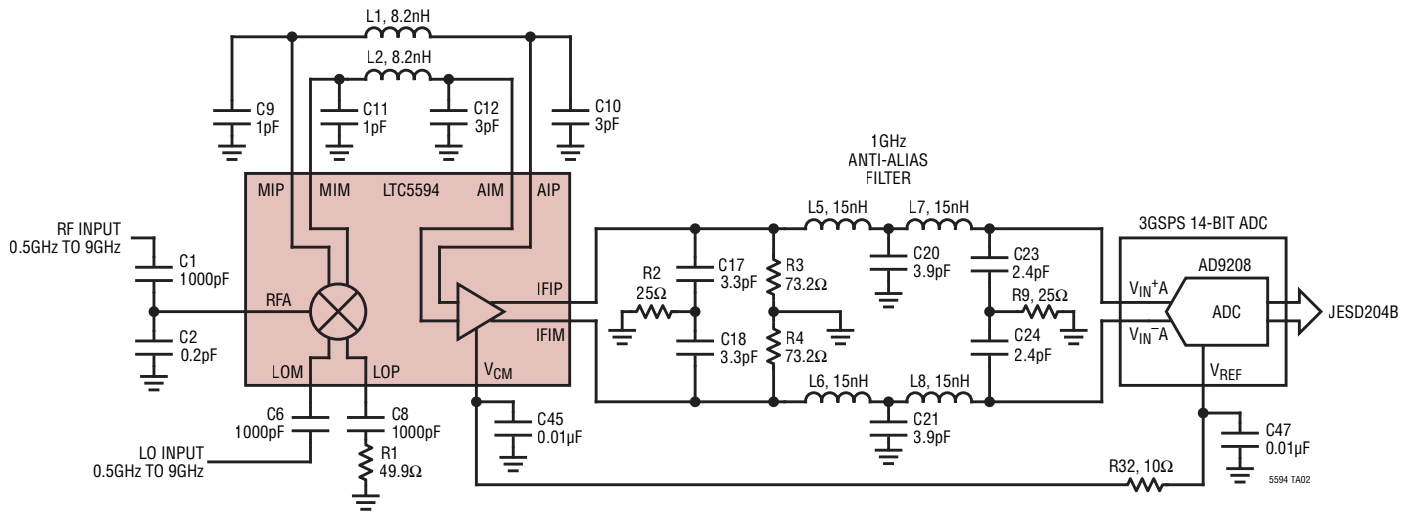

RELATED PARTS

PART NUMBER	DESCRIPTION	COMMENTS
Infrastructure		
LTC5553	3GHz to 20GHz Microwave Mixer with 500MHz to 9GHz IF	Up-or-Down Conversion, 21.5dBm IIP3 at 17GHz, 0dBm LO Drive
LTC5552	3GHz to 20GHz Microwave Mixer with DC to 6GHz IF	Up-or-Down Conversion, 18.3dBm IIP3 at 17GHz, 0dBm LO Drive
LTC5549	2GHz to 14GHz Mixer with Integrated LO Doubler	Ultra-Wideband Bidirectional Up-, or Down-Conversion Mixer, 22.8dBm IIP3 at 12GHz, 0dBm LO Drive, 500MHz to 6GHz IF Bandwidth
LTC5548	2GHz to 14GHz Mixer with IF Frequency Extending to DC	Ultra-Wideband Bidirectional Up-, or Down-Conversion Mixer, 18.7dBm IIP3 at 12GHz, 0dBm LO Drive with On-Chip Frequency Doubler, DC to 6GHz IF Bandwidth
LTC5588-1	200MHz to 6GHz Quadrature Modulator	31dBm OIP3, -160dBm/Hz Output Noise Floor, Excellent ACPR Performance
LTC6433-15	<100kHz to 1.4GHz High OIP3 Amplifier	Fixed 15dB Gain, Single-Ended 50Ω Input and Output, 41dBm OIP3 at 240MHz, 3.3dB NF
RF PLL/Synthesizer with VCO		
ADF5355	Microwave Wideband Synthesizer with Integrated VCO	54MHz to 13.6GHz, -221dBc/Hz Normalized In-Band Phase Noise Floor
LTC6948	Ultralow Noise Fractional-N Synthesizer with Integrated VCO	370MHz to 6.39GHz PLL, No ΔΣ Modulator Spurs, 18-Bit Fractional Denominator, -226dBc/Hz Normalized In-Band Phase Noise Floor
ADCs		
AD9208	14-Bit, 3Gsp/s JESD204B Dual ADC	70dB SFDR, Integrated Input Buffer
LTC2185	16-Bit, 125Msp/s 1.8V Dual ADC	76.8dB SNR, 90dB SFDR, 185mW/Channel Power Consumption
LTC2158-14	14-Bit, 310Msp/s 1.8V Dual ADC, 1.25GHz Full-Power Bandwidth	68.8dB SNR, 88dB SFDR, 362mW/Ch Power Consumption, 1.32V _{p-p} Input Range

Looking for pricing, stock, or lifecycle information?

Click below to explore more details on WIN SOURCE:

 [View LTC5594IUH#PBF on WIN SOURCE](#)

 [Analog Devices Inc. Information](#)

Optimize Your Supply Chain with WIN SOURCE Solutions

-  Global Sourcing Solution
-  Obsolete Management
-  Cost Control Management
-  Shortage Management
-  Alternative Solution
-  Excess Inventory Management