



**THE DATASHEET OF
LTC4257CDD#PBF**



IEEE 802.3af PD Power over Ethernet Interface Controller

FEATURES

- Complete Power Interface Port for IEEE 802.3af[®] Powered Devices (PDs)
- Onboard 100V, 400mA Power MOSFET
- Precision Input Current Limit
- Onboard 25k Signature Resistor
- Programmable Classification Current (Class 0-4)
- Undervoltage Lockout
- Smart Thermal Protection
- Power Good Signal
- Available in 8-Pin SO and Low Profile (3mm × 3mm) DFN Packages

APPLICATIONS

- IP Phone Power Management
- Wireless Access Points
- Telecom Power Control

DESCRIPTION

The LTC[®]4257 provides complete signature and power interface functions for a device operating in an IEEE 802.3af Power over Ethernet (PoE) system. The LTC4257 simplifies Powered Device (PD) design by incorporating the 25k signature resistor, the classification current source, input current limit with thermal foldback, undervoltage lockout and power good signalling, all in a single 8-pin package. By incorporating a high voltage power MOSFET onboard, the LTC4257 provides the system designer with reduced cost while also saving board space.

The LTC4257 can interface directly with a variety of Linear Technology DC/DC converter products to provide a cost effective power solution for IP phones, wireless access points and other PDs. Linear Technology also provides solutions for Power Sourcing Equipment (PSE) applications with quad network power controllers.

The LTC4257 is available in the 8-pin SO and low profile (3mm × 3mm) DFN packages.

LT, LTC and LT are registered trademarks of Linear Technology Corporation. All other trademarks are the property of their respective owners.

TYPICAL APPLICATION

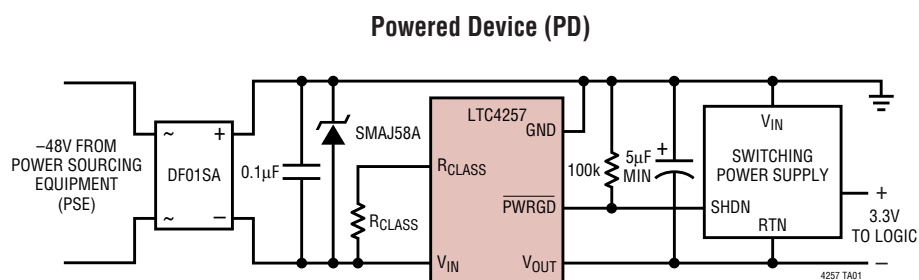

**LTC4257 Charging 300µF
Load Capacitor**

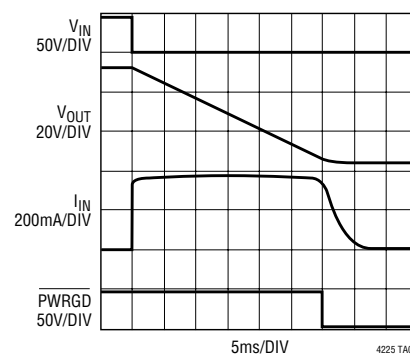

ABSOLUTE MAXIMUM RATINGS

(Notes 1, 2)

V_{IN} Voltage	0.3V to -100V
V_{OUT} , PWRGD Voltage	$V_{IN} + 100V$ to $V_{IN} - 0.3V$
R_{CLASS} Voltage	$V_{IN} + 7V$ to $V_{IN} - 0.3V$
PWRGD Current	10mA
R_{CLASS} Current	100mA

Operating Ambient Temperature Range	
LTC4257C	0°C to 70°C
LTC4257I	-40°C to 85°C
Storage Temperature Range	
S8 Package	-65°C to 150°C
DD Package	-65°C to 125°C
Lead Temperature (Soldering, 10 sec)	
	300°C

PACKAGE/ORDER INFORMATION

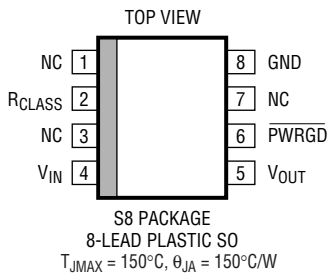
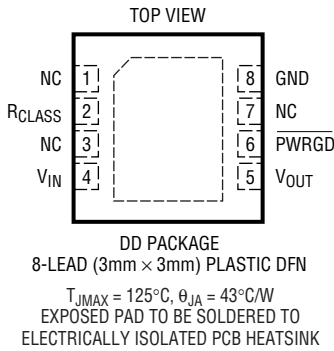
 <p>S8 PACKAGE 8-LEAD PLASTIC SO $T_{JMAX} = 150^{\circ}C$, $\theta_{JA} = 150^{\circ}C/W$</p>		 <p>DD PACKAGE 8-LEAD (3mm x 3mm) PLASTIC DFN $T_{JMAX} = 125^{\circ}C$, $\theta_{JA} = 43^{\circ}C/W$ EXPOSED PAD TO BE SOLDERED TO ELECTRICALLY ISOLATED PCB HEATSINK</p>	
ORDER PART NUMBER	S8 PART MARKING	ORDER PART NUMBER	DD PART MARKING*
LTC4257CS8 LTC4257IS8	4257 4257I	LTC4257CDD LTC4257IDD	LACT
Order Options Tape and Reel: Add #TR Lead Free: Add #PBF Lead Free Tape and Reel: Add #TRPBF Lead Free Part Marking: http://www.linear.com/leadfree/			

Consult LTC Marketing for parts specified with wider operating temperature ranges. *The temperature grades are identified by a label on the shipping container.

ELECTRICAL CHARACTERISTICS

The ● denotes the specifications which apply over the full operating temperature range, otherwise specifications are at $T_A = 25^{\circ}C$. (Note 3)

SYMBOL	PARAMETER	CONDITIONS	MIN	TYP	MAX	UNITS	
V_{IN}	Supply Voltage	Voltage with Respect to GND Pin (Notes 4, 5, 6)					
	Maximum Operating Voltage		●		-57	V	
	Signature Range		●	-1.5	-9.5	V	
	Classification Range		●	-12.5	-21	V	
	UVLO Turn-On Voltage		●	-37.7	-39.2	-40.2	V
	UVLO Turn-Off Voltage		●	-29.3	-30.5	-31.5	V
I_{IN_ON}	IC Supply Current when ON	$V_{IN} = -48V$, Pins 5, 6 Floating	●		3	mA	
I_{IN_CLASS}	IC Supply Current During Classification	$V_{IN} = -17.5V$, Pin 2 Floating, V_{OUT} Tied to GND (Note 7)	●	0.35	0.50	0.65	mA
ΔI_{CLASS}	Current Accuracy During Classification	$10mA < I_{CLASS} < 40mA$, $-12.5V \leq V_{IN} \leq -21V$, (Notes 8, 9)	●		± 3.5	%	

ELECTRICAL CHARACTERISTICS

The ● denotes the specifications which apply over the full operating temperature range, otherwise specifications are at $T_A = 25^\circ\text{C}$. (Note 3)

SYMBOL	PARAMETER	CONDITIONS	MIN	TYP	MAX	UNITS	
$R_{\text{SIGNATURE}}$	Signature Resistance	$-1.5\text{V} \leq V_{\text{IN}} \leq -9.5\text{V}$, V_{OUT} Tied to GND, IEEE 802.3af 2-Point Measurement (Notes 4, 5)	● 23.25		26.00	$\text{k}\Omega$	
$V_{\text{PG_OUT}}$	Power Good Output Low Voltage	$I = 1\text{mA}$, $V_{\text{IN}} = -48\text{V}$, $\overline{\text{PWRGD}}$ Referenced to V_{IN}	●		0.5	V	
$V_{\text{PG_THRES_FALL}}$	Power Good Trip Point	$V_{\text{IN}} = -48\text{V}$, Voltage Between V_{IN} and V_{OUT} (Note 9)	●	1.3	1.5	1.7	V
$V_{\text{PG_THRES_RISE}}$		V_{OUT} Falling V_{OUT} Rising	●	2.7	3.0	3.3	V
$I_{\text{PG_LEAK}}$	Power Good Leakage	$V_{\text{IN}} = 0\text{V}$, $\overline{\text{PWRGD}}$ FET Off, $\overline{V_{\text{PWRGD}}} = 57\text{V}$	●		1	μA	
R_{ON}	On-Resistance	$I = 300\text{mA}$, $V_{\text{IN}} = -48\text{V}$, Measured from V_{IN} to V_{OUT} (Note 9)	●	1.0	1.6	Ω	
$I_{\text{OUT_LEAK}}$	V_{OUT} Leakage	$V_{\text{IN}} = 0\text{V}$, Power MOSFET Off, $V_{\text{OUT}} = 57\text{V}$ (Note 10)	●		150	μA	
I_{LIMIT}	Input Current Limit	$V_{\text{IN}} = -48\text{V}$, $V_{\text{OUT}} = -43\text{V}$ (Note 11)	●	300	350	400	mA
$I_{\text{LIMIT_WARM}}$	Overtemperature Input Current Limit	(Note 11)		188		mA	
T_{OVERTEMP}	Overtemperature Trip Temperature	(Note 11)		120		$^\circ\text{C}$	
T_{SHUTDOWN}	Thermal Shutdown Trip Temperature	(Note 11)		140		$^\circ\text{C}$	

Note 1: Stresses beyond those listed under Absolute Maximum Ratings may cause permanent damage to the device. Exposure to any Absolute Maximum Rating condition for extended periods may affect device reliability and lifetime.

Note 2: All voltages are with respect to GND pin.

Note 3: The LTC4257 operates with a negative supply voltage in the range of -1.5V to -57V . To avoid confusion, voltages in this data sheet are always referred to in terms of absolute magnitude. Terms such as “maximum negative voltage” refer to the largest negative voltage and a “rising negative voltage” refers to a voltage that is becoming more negative.

Note 4: The LTC4257 is designed to work with two polarity protection diodes between the PSE and PD. Parameter ranges specified in the Electrical Characteristics are with respect to LTC4257 pins and are designed to meet IEEE 802.3af specifications when these diode drops are included. See Applications Information.

Note 5: Signature resistance is measured via the 2-point $\Delta V/\Delta I$ method as defined by IEEE 802.3af. The LTC4257 signature resistance is offset from 25k to account for diode resistance. With two series diodes, the total PD resistance will be between 23.75k and 26.25k and meet IEEE 802.3af specifications. The minimum probe voltages measured at the LTC4257 pins are -1.5V and -2.5V . The maximum probe voltages are -8.5V and -9.5V .

Note 6: The LTC4257 includes hysteresis in the UVLO voltages to preclude any start-up oscillation. Per IEEE 802.3af requirements, the LTC4257 will

power up from a voltage source with 20Ω series resistance on the first trial.

Note 7: $I_{\text{IN_CLASS}}$ does not include classification current programmed at Pin 2. Total supply current in classification mode will be $I_{\text{IN_CLASS}} + I_{\text{CLASS}}$ (see Note 8).

Note 8: I_{CLASS} is the measured current flowing through R_{CLASS} . ΔI_{CLASS} accuracy is with respect to the ideal current defined as $I_{\text{CLASS}} = 1.237/R_{\text{CLASS}}$. The current accuracy specification does not include variations in R_{CLASS} resistance. The total classification current for a PD also includes the IC quiescent current ($I_{\text{IN_CLASS}}$). See Applications Information.

Note 9: For the DD package, this parameter is assured by design and wafer level testing.

Note 10: $I_{\text{OUT_LEAK}}$ includes current drawn at the V_{OUT} pin by the power good status circuit. This current is compensated for in the $25\text{k}\Omega$ signature resistance and does not affect PD operation.

Note 11: The LTC4257 includes smart thermal protection. In the event of an overtemperature condition, the LTC4257 will reduce the input current limit by 50% to reduce the power dissipation in the package. If the part continues heating and reaches the shutdown temperature, the current is reduced to zero until the part cools below the overtemperature limit. The LTC4257 is also protected against thermal damage from incorrect classification probing by the PSE. If the LTC4257 exceeds the overtemperature trip point, the classification load current is disabled.

TYPICAL PERFORMANCE CHARACTERISTICS

**Input Current vs Input Voltage
25k Detection Range**

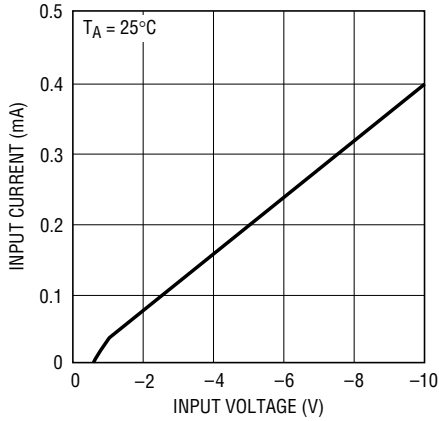

4357 G02

Input Current vs Input Voltage

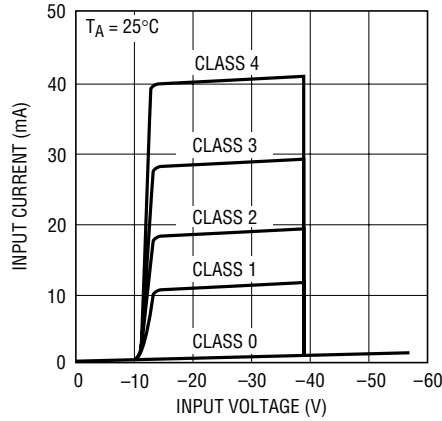

4257 G01

Input Current vs Input Voltage

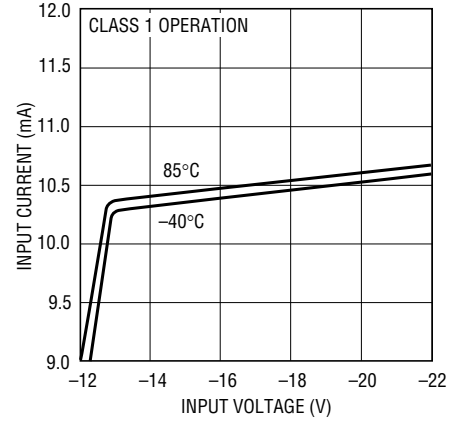

4257 G03

Input Current vs Input Voltage

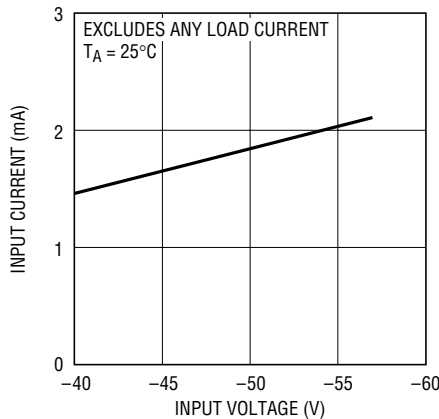

4257 G04

Signature Resistance vs Input Voltage

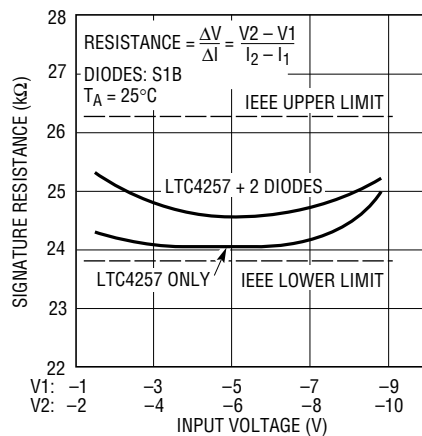

4257 G05

Normalized UVLO Threshold vs Temperature

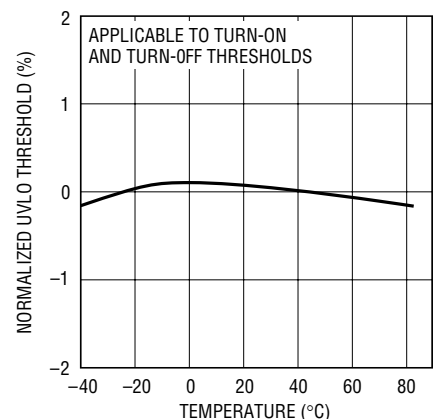

4257 G06

Power Good Output Low Voltage vs Current

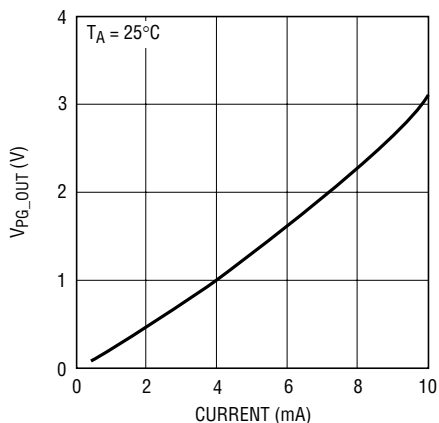

4257 G07

VOUT Leakage Current

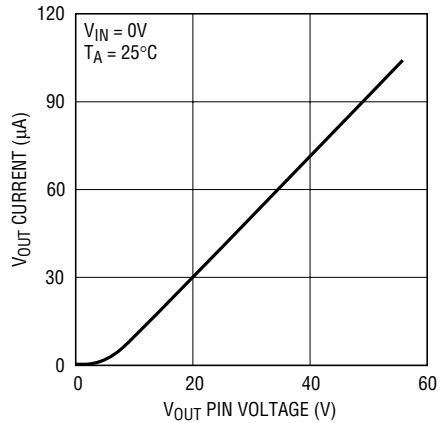

4257 G09

Current Limit vs Input Voltage

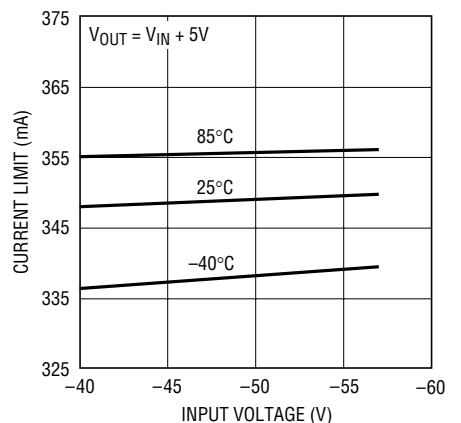

4257 G09

PIN FUNCTIONS

NC (Pin 1): No Connect.

R_{CLASS} (Pin 2): External Class Select Input. Used to set the current the LTC4257 maintains during classification. Connect a resistor between R_{CLASS} and V_{IN} (see Table 2).

NC (Pin 3): No Connect.

V_{IN} (Pin 4): Power Input. Tie to system –48V through the input diode bridge.

V_{OUT} (Pin 5): Power Output. Supplies –48V to the PD load through an internal power MOSFET that limits input current. V_{OUT} is high impedance until the input voltage rises above the turn-on UVLO threshold. Above the UVLO threshold the output is current limited to 350mA.

PWRGD (Pin 6): Power Good Output, Open-Drain. Signals that the LTC4257 MOSFET is fully on. Low impedance indicates power is good. PWRGD is high impedance during detection, classification and in the event of a thermal overload. PWRGD is referenced to V_{IN}.

NC (Pin 7): No Connect

GND (Pin 8): Ground. Tie to system ground and to power return through the input diode bridge.

BLOCK DIAGRAM

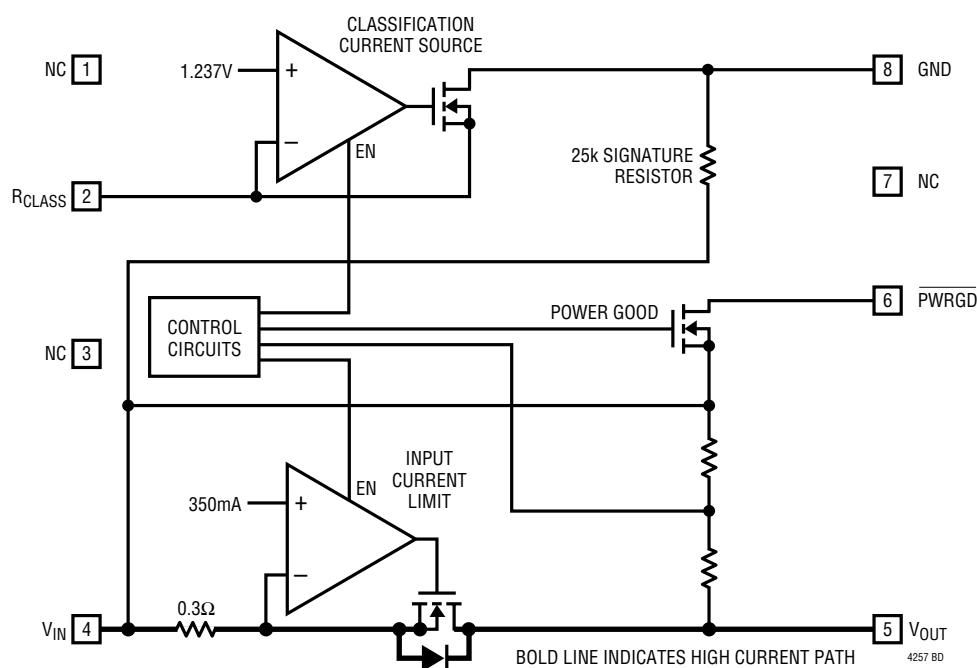

APPLICATIONS INFORMATION

The LTC4257 is intended for use as the front end of a Powered Device (PD) designed to IEEE 802.3af draft standard. The LTC4257 includes a trimmed 25k signature resistor, classification current source, and an inrush current limit circuit. With these functions integrated into the LTC4257, the signature and power interface for a PD that meets all the requirements of IEEE 802.3af can be built with a minimum of external components.

Using an LTC4257 for the power and signature interface functions of a PD provides several advantages. The LTC4257 current limit circuit includes an onboard, 100V, 400mA power MOSFET with low leakage. This onboard low leakage MOSFET avoids the possibility of corrupting the 25k signature resistor while also saving board space and cost. In addition, the IEEE 802.3af inrush current limit requirement causes large transient power dissipation in the PD; the LTC4257 manages this turn-on sequence through the use of smart thermal protection circuitry. The LTC4257 is designed to allow multiple turn-on sequences without overheating the miniature 8-lead package. In the event of excessive power cycling, the LTC4257 provides thermally activated current-limit reduction to keep the onboard power MOSFET within its safe operating area.

Operation

The LTC4257 has several modes of operation depending on the applied input voltage as shown in Figure 1 and summarized in Table 1. These various modes satisfy the requirements defined in the IEEE 802.3af specification. The input voltage is applied to the V_{IN} pin and is with reference to the GND pin. This input voltage is always negative. To avoid confusion, voltages in this data sheet are always referred to in terms of absolute magnitude. Terms such as *maximum negative voltage* refer to the largest negative voltage and a *rising negative voltage* refers to a voltage that is becoming more negative. References to electrical parameters in this applications section use the nominal value. Refer to the Electrical Characteristics section for the range of values a particular parameter will have.

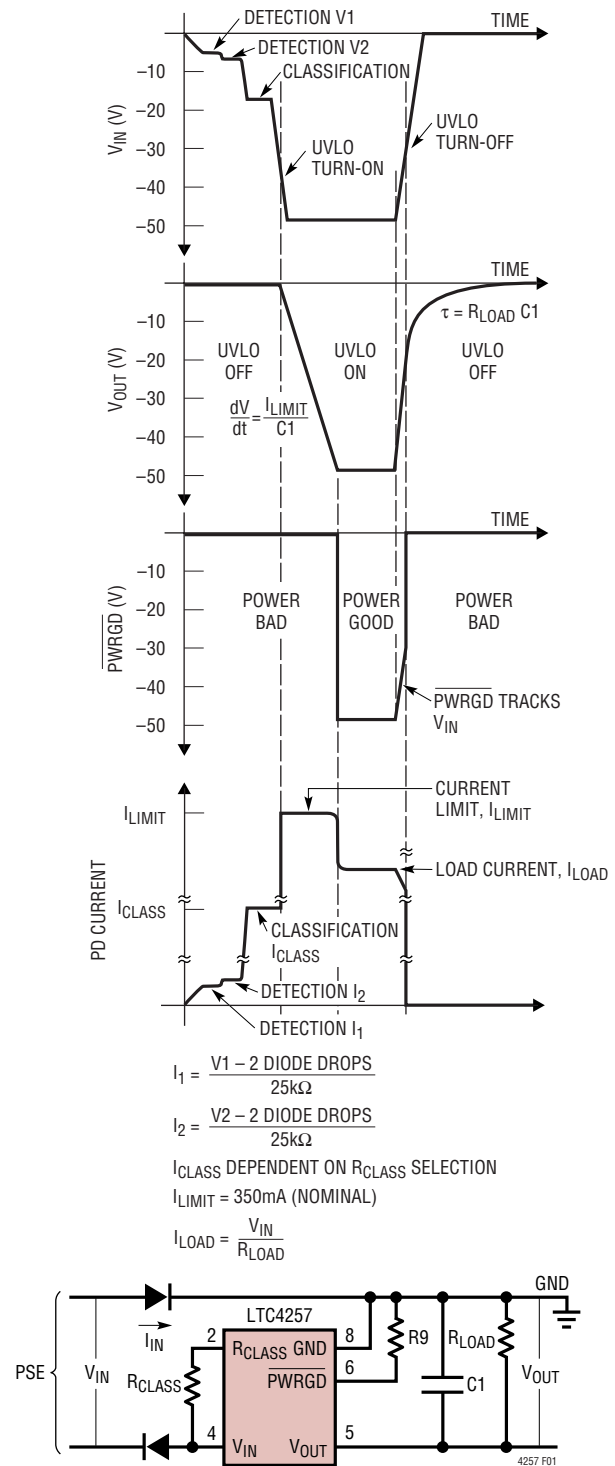

Figure 1. Output Voltage, PWRGD and PD Current as a Function of Input Voltage

APPLICATIONS INFORMATION

Table 1. LTC4257 Operational Mode as a Function of Input Voltage

INPUT VOLTAGE (V_{IN} with RESPECT to GND)	LTC4257 MODE OF OPERATION
0V to -1.4V	Inactive
-1.5V to -10V	25k Signature Resistor Detection
-11V to -12.4V	Classification Load Current Ramps up from 0% to 100%
-12.5V to UVLO*	Classification Load Current Active
UVLO* to -57V	Power Applied to PD Load

*UVLO includes hysteresis.

Rising input threshold $\cong -39.2V$

Falling input threshold $\cong -30.5V$

Series Diodes

The IEEE 802.3af defined operating modes for a PD reference the input voltage at the RJ45 connector on the PD. However, PD circuitry must include diode bridges between the RJ45 connector and the LTC4257 (Figure 2). The LTC4257 takes this into account by compensating for these diode drops in the threshold points for each range of operation. Since the voltage ranges specified in the LTC4257 electrical specifications are with respect to the IC pins for both the signature and classification ranges, the LTC4257 lower end extends two diode drops below the IEEE 802.3af specification. A similar adjustment is made for the UVLO voltages.

Detection

During detection, the PSE will apply a voltage in the range of -2.8V to -10V on the cable and look for a 25k signature resistor. This identifies the device at the end of the cable as a PD. With the terminal voltage in this range, the LTC4257 connects an internal 25k resistor between GND and the V_{IN} pins. This precision, temperature compensated resistor presents the proper characteristics to alert the Power Sourcing Equipment (PSE) at the other end of the cable that a PD is present and desires power to be applied.

The power applied to a PD is allowed to use either of two polarities and the PD must be able to accept this power so it is common to install a diode bridge on the input. The LTC4257 is designed to compensate for the voltage and resistance effects of these two series diodes. The signature range extends below the IEEE range to accommodate the voltage drop of the diodes. The IEEE specification requires the PSE to use a $\Delta V/\Delta I$ measurement technique to keep the DC offset of these diodes from affecting the signature resistance measurement. However, the diode resistance appears in series with the signature resistor and must be included in the overall signature resistance of the PD. The LTC4257 compensates for the two series diodes in the signature path by offsetting the resistance so that a PD built using the LTC4257 will meet the IEEE requirements.

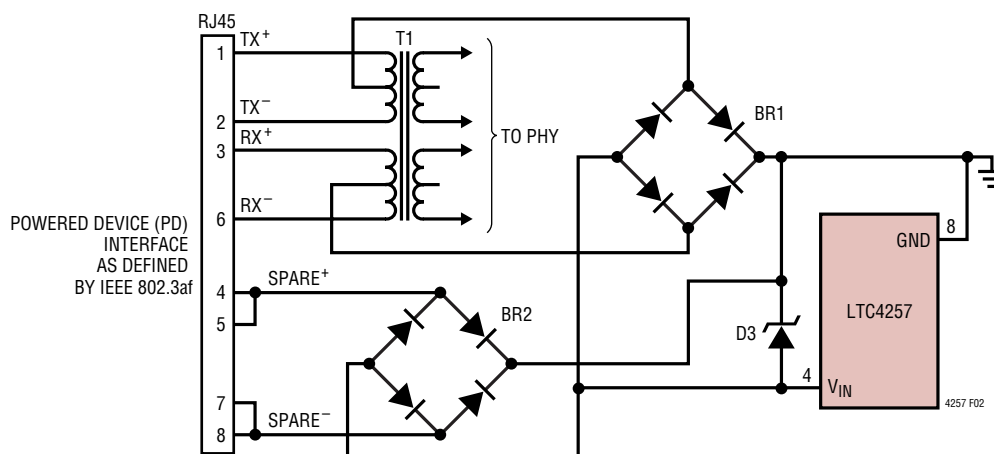

Figure 2. PD Front End Using Diode Bridges on Main and Spare Inputs

APPLICATIONS INFORMATION

Classification

Once the PSE has detected a PD, the PSE may optionally classify the PD. Classification provides a method for more efficient allocation of power by allowing the PSE to identify lower-power PDs and allocate less power for these devices. IEEE 802.3af defines five classes (Table 2) with varying power levels. The designer selects the appropriate classification based on the power consumption of the PD. For each class, there is an associated load current that the PD asserts onto the line during classification probing. The PSE measures the PD load current to determine the proper classification and PD power requirements.

Table 2. Summary of IEEE 802.3af Power Classifications and LTC4257 R_{CLASS} Resistor Selection

CLASS	USAGE	MAXIMUM POWER LEVELS AT INPUT OF PD (W)	NOMINAL CLASSIFICATION LOAD CURRENT (mA)	LTC4257 R _{CLASS} RESISTOR (Ω, 1%)
0	Default	0.44 to 12.95	<5	Open
1	Optional	0.44 to 3.84	10.5	124
2	Optional	3.84 to 6.49	18.5	68.1
3	Optional	6.49 to 12.95	28	45.3
4	Reserved	Reserved*	40	30.9

*Class 4 is currently reserved and should not be used.

Early revisions of the IEEE 802.3af draft specification defined two methods that a PSE could use in order to perform PD classification. These methods are known as

Measured Current and Measured Voltage. The IEEE has since removed the Measured Voltage method from the specification. The LTC4257 is compatible with the IEEE 802.3af standard and also works with the obsolete Measured Voltage method.

In the Measured Current method (Figure 3), the PSE presents a fixed voltage between -15.5V and -20V to the PD. With the input voltage in this range, the LTC4257 asserts a load current from the GND pin through the R_{CLASS} resistor. The magnitude of the load current is set with the selection of the R_{CLASS} resistor. The resistor value associated with each class is shown in Table 2.

In the Measured Voltage method (Figure 4), the PSE drives a current into the PD and monitors the voltage across the PD terminals. The PSE current steps between classification load current values in order to classify the PD under test. For PSE probe currents below the PD load current, the LTC4257 will keep the PD terminal voltage below the classification voltage range. For PSE probe currents above the PD load current, the LTC4257 will force the PD terminal voltage above the classification voltage range.

During classification, a moderate amount of power is dissipated in the LTC4257. IEEE 802.3af limits the classification time to 75ms. The LTC4257 is designed to handle the power dissipation for this time period. If the PSE

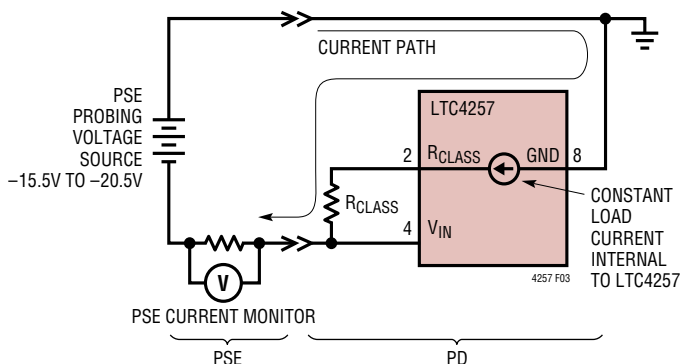

Figure 3. IEEE 802.3af Measured-Current Method of Classification Probing

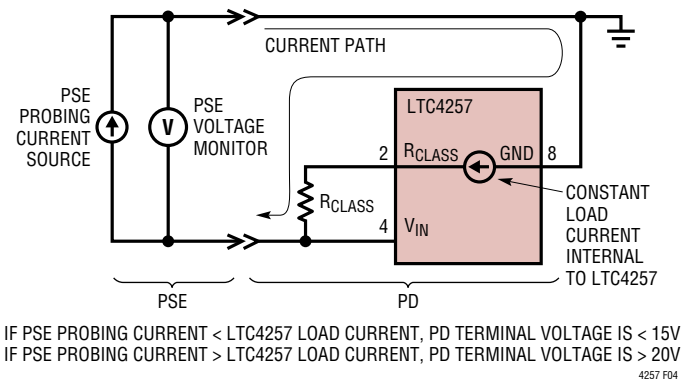

Figure 4. IEEE 802.af Measured-Voltage Method of Classification Probing

APPLICATIONS INFORMATION

probing exceeds 75ms, the LTC4257 may overheat. In this situation, the thermal protection circuit will engage and disable the classification current source in order to protect the part. The LTC4257 stays in classification mode until the input voltage rises above the UVLO turn-on voltage.

Undervoltage Lockout

IEEE 802.3af dictates a maximum turn-on voltage of 42V and a minimum turn-off voltage of 30V for the PD. In addition, the PD must maintain large on-off hysteresis to prevent resistive losses in the wiring between the PSE and the PD from causing start-up oscillation. The LTC4257 incorporates an undervoltage lockout (UVLO) circuit that monitors line voltage to determine when to apply power to the PD load (Figure 5). Before power is applied to the load, the V_{OUT} pin is high impedance and at ground potential since there is no charge on capacitor C1. When the input voltage rises above the UVLO turn-on threshold, the LTC4257 removes the classification load current and turns on the internal power MOSFET. C1 charges up under LTC4257 current limit control and the V_{OUT} pin transitions

from 0V to V_{IN} . This sequence is shown in Figure 1. The LTC4257 includes a hysteretic UVLO circuit that keeps power applied to the load until the input voltage falls below the UVLO turn-off threshold. Once the input voltage drops below $-30V$, the internal power MOSFET is turned off and the classification load current is re-enabled. C1 will discharge through the PD circuitry and the V_{OUT} pin will go to a high impedance state.

Input Current Limit

IEEE 802.3af specifies a maximum inrush current and also specifies a minimum load capacitor between the GND and V_{OUT} pins. To control turn-on surge current in the system, the LTC4257 integrates a current limit circuit with the onboard power MOSFET and sense resistor to provide a complete inrush control circuit without additional external components. The LTC4257 limits input current to less than the 400mA maximum specified by 802.3af, allowing the load capacitor to ramp up to the line voltage in a controlled manner. During this ramp up, a large amount of power is dissipated in the power MOSFET. The LTC4257

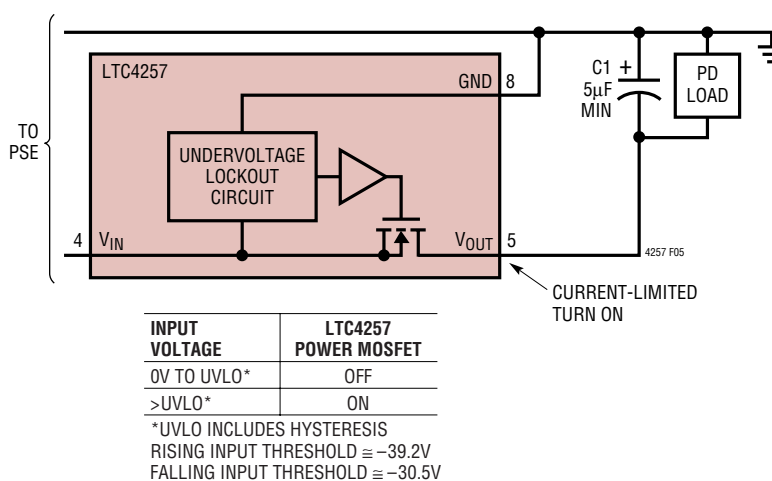

Figure 5. LTC4257 Undervoltage Lockout

APPLICATIONS INFORMATION

is designed to accept this thermal load and is thermally protected to avoid damage to the onboard power MOSFET. Note that the PD designer must ensure that the PD steady-state power consumption falls within the limits shown in Table 2.

Power Good

The LTC4257 includes a power good circuit (Figure 6) that is used to indicate to the PD circuitry that load capacitor C1 is fully charged and that the PD can start DC/DC converter operation. The power good circuit monitors the voltage across the internal power MOSFET and $\overline{\text{PWRGD}}$ is asserted when the voltage drops below 1.5V. The power good circuit includes a large amount of hysteresis to allow the LTC4257 to operate near the current limit point without inadvertently disabling $\overline{\text{PWRGD}}$. The MOSFET voltage must increase to 3V before $\overline{\text{PWRGD}}$ is disabled.

If a sudden increase in voltage appears on the input line, this voltage step will be transferred through capacitor C1 and appear across the power MOSFET. The response of the LTC4257 will depend on the magnitude of the voltage step, the rise time of the step, the value of capacitor C1 and the DC load. For fast rising inputs, the LTC4257 will attempt to quickly charge capacitor C1 using an internal secondary current limit circuit. In this scenario, the PSE current limit should provide the overall limit for the circuit. For slower rising inputs, the 350mA current limit in the LTC4257 will set the charge rate of capacitor C1. In either case, the $\overline{\text{PWRGD}}$ signal may go inactive briefly while the capacitor is charged up to the new line voltage. In the

design of a PD, it is necessary to determine if a step in the input voltage will cause the $\overline{\text{PWRGD}}$ signal to go inactive and how to respond to this event. In some designs, the charge on C1 is sufficient to power the PD through this event. In this case, it may be desirable to filter the $\overline{\text{PWRGD}}$ signal so that intermittent power bad conditions are ignored. Figure 10 demonstrates methods to insert a lowpass filter on the power good interface.

For PD designs that use a large load capacitor and also consume a lot of power, it is important to delay activation of the PD circuitry with the $\overline{\text{PWRGD}}$ signal. If the PD circuitry is not disabled during the current-limited turn-on sequence, the PD circuitry will rob current intended for charging up the load capacitor and create a slow rising input, possibly causing the LTC4257 to go into thermal shutdown.

The $\overline{\text{PWRGD}}$ pin connects to an internal open-drain, 100V transistor capable of sinking 1mA. Low impedance indicates power is good. $\overline{\text{PWRGD}}$ is high impedance during signature and classification probing and in the event of a thermal overload.

During turn-off, $\overline{\text{PWRGD}}$ is deactivated when the input voltage drops below 30V. In addition, $\overline{\text{PWRGD}}$ may go active briefly at turn-on for fast rising input waveforms. $\overline{\text{PWRGD}}$ is referenced to the V_{IN} pin and when active will be near the V_{IN} potential. The PD DC/DC converter will typically be referenced to V_{OUT} and care must be taken to ensure that the difference in potential of the $\overline{\text{PWRGD}}$ signal does not cause any detrimental effects. Use of diode clamp D6, as shown in Figure 10, will alleviate any problems.

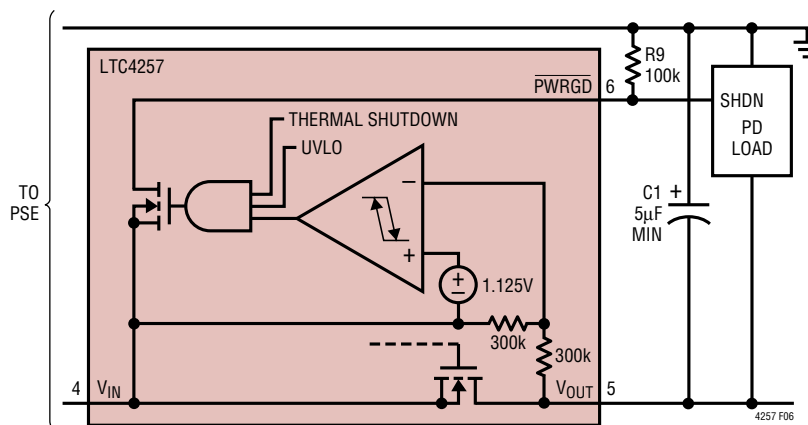

Figure 6. LTC4257 Power Good

APPLICATIONS INFORMATION

Thermal Protection

The LTC4257 includes smart thermal protection in order to provide full device functionality in a miniature package while maintaining safe operating temperatures. Several factors create the possibility for tremendous power dissipation within the LTC4257. IEEE 802.3af mandates that inrush current be limited to less than 400mA while standard telecom power can be as high as 57V. At turn on, before the load capacitor has charged up, the instantaneous power dissipated by the LTC4257 can be over 20W. As the load capacitor charges up, the power dissipation in the LTC4257 will decrease until it reaches a steady-state value dependent on the DC load current. The size of the load capacitor determines how fast the power dissipation in the LTC4257 subsides. At room temperature, the LTC4257 can handle load capacitors as large as 800 μ F without going into thermal shutdown. With a large load capacitor like this, the LTC4257 die temperature will increase by about 50°C during a single turn-on sequence. If for some reason power were removed from the part and then quickly reapplied so that the LTC4257 had to charge up the load capacitor again, the temperature rise would be excessive if safety precautions were not implemented.

The LTC4257 protects itself from thermal damage by monitoring the die temperature. If the die temperature exceeds the overtemperature trip point, the part switches to a half-power mode where the current limit is set to 50% of its normal level. This reduces power dissipation and helps prevent further heating. If the part continues to heat up and reaches the shutdown temperature, the current is reduced to zero and very little power is dissipated in the

part until it cools below the overtemperature set point. The LTC4257 current limit will continue switching between 0%, 50% and 100% current levels (Figure 7) until the load capacitor is fully charged.

If the PD is designed to operate at a high ambient temperature and with the maximum allowable supply (57V), there will be a limit to the size load capacitor that can be charged up before the LTC4257 reaches the overtemperature trip point. Hitting the overtemperature trip point intermittently does not harm the LTC4257, but it will delay completion of capacitor charging. Capacitors up to 200 μ F can be charged without a problem.

During classification, excessive heating of the LTC4257 can occur if the PSE violates the 75ms probing time limit. To protect the LTC4257, the thermal protection circuitry will disable classification current if the die temperature exceeds the overtemperature trip point. When the die cools down below the trip point, classification current is re-enabled.

Once the LTC4257 has charged up to the load capacitor and the PD is powered and running, there will be some residual heating due to the DC load current of the PD flowing through the internal MOSFET. In some applications, the LTC4257 power dissipation may be significant and if dissipated in the S8 package, excessive package heating could occur. This problem can be solved with the use of the DD package which has superior thermal performance. The DD package includes an exposed pad that should be soldered to an isolated heatsink on the printed circuit board.

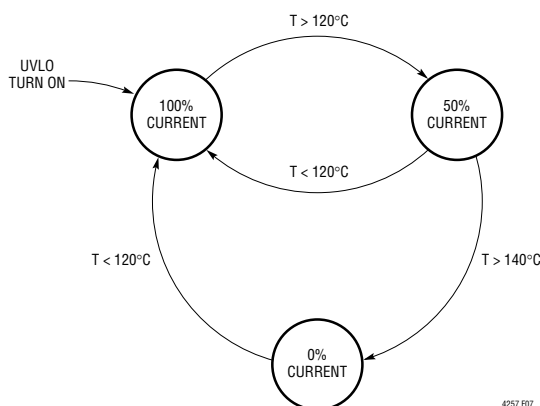

Figure 7. Smart Thermal Protection State Diagram

APPLICATIONS INFORMATION

EXTERNAL INTERFACE AND COMPONENT SELECTION

Transformer

Nodes on an Ethernet network commonly interface to the outside world via an isolation transformer (Figure 8). For powered devices, the isolation transformer must include a center tap on the media (cable) side. Proper termination is required around the transformer to provide correct impedance matching and to avoid radiated and conducted emissions. Transformer vendors such as Pulse, Bel Fuse, Tyco and others (Table 3) can provide assistance with selection of an appropriate isolation transformer and proper termination methods. These vendors have transformers specifically designed for use in PD applications.

Table 3. Power over Ethernet Transformer Vendors

VENDOR	CONTACT INFORMATION
Pulse Engineering	12220 World Trade Drive San Diego, CA 92128 Tel: 858-674-8100 FAX: 858-674-8262 http://www.pulseeng.com/
Bel Fuse Inc.	206 Van Vorst Street Jersey City, NJ 07302 Tel: 201-432-0463 FAX: 201-432-9542 http://www.belfuse.com/
Tyco Electronics	308 Constitution Drive Menlo Park, CA 94025-1164 Tel: 800-227-7040 FAX: 650-361-2508 http://www.circuitprotection.com/

Diode Bridges

IEEE 802.3af allows power wiring in either of two configurations on the TX/RX wires, plus power can be applied to the PD via the spare wire pair in the RJ45 connector. The PD is required to accept power in either polarity on both the main and spare inputs, therefore it is common to install diode bridges on both inputs in order to accommodate the different wiring configurations. Figure 8 demonstrates an implementation of these diode bridges. The specification also mandates that the leakage back through the unused bridge be less than $28\mu\text{A}$ when the PD is powered with 57V .

The IEEE standard includes an AC impedance requirement in order to implement the AC disconnect function. Capacitor C14 in Figure 8 is used to meet this AC impedance requirement. A $0.1\mu\text{F}$ capacitor is recommended for this application.

The LTC4257 has several different modes of operation based on the voltage present between the V_{IN} and GND pins. The forward voltage drop of the input diodes in a PD design subtracts from the input voltage and will affect the transition point between modes. When using the LTC4257, it is necessary to pay close attention to this forward voltage drop. Selection of oversized diodes will help keep the PD thresholds from exceeding IEEE specifications.

The input diode bridge of a PD can consume 4% of the available power in some applications. It may be desirable to use Schottky diodes in order to reduce this power loss.

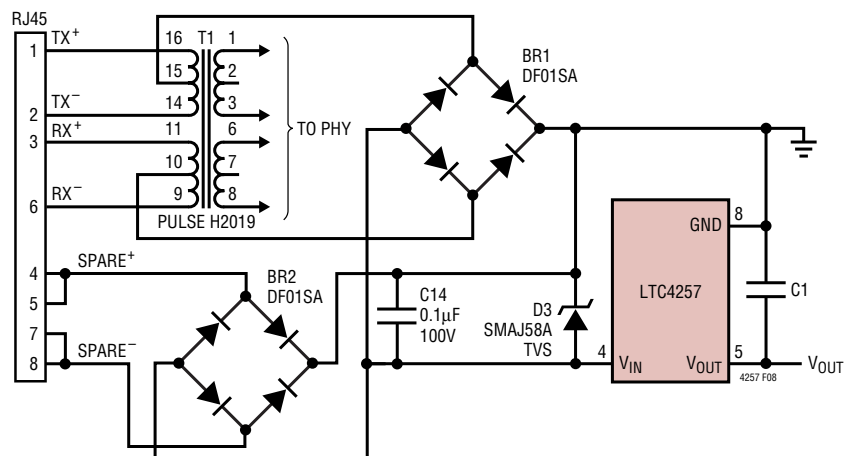

Figure 8. PD Front End with Isolation Transformer, Diode Bridges and Capacitor

APPLICATIONS INFORMATION

However, if the standard diode bridge is replaced with a Schottky bridge, the transition points between modes will be affected. The application circuit (Figure 11) shows a technique for using Schottky diodes while maintaining proper threshold points to meet IEEE 802.3af compliance.

Auxiliary Power Source

In some applications, it may be desirable to power the PD from an auxiliary power source such as a wall transformer. The auxiliary power can be injected into the PD at several locations and various trade-offs exist. Power can be injected at the 3.3V or 5V output of the isolated power supply with the use of a diode ORing circuit. This method accesses the internal circuits of the PD after the isolation barrier and therefore meets the 802.3af isolation safety requirements for the wall transformer jack on the PD. Power can also be injected into the PD interface portion of the LTC4257. In this case, it is necessary to ensure the user cannot access the terminals of the wall transformer jack on the PD since this would compromise the 802.3af isolation safety requirements. Figure 9 demonstrates three methods of diode ORing external power into a PD. Option 1 inserts power before the LTC4257 while options 2 and 3 insert power after the LTC4257.

If power is inserted before the LTC4257 (option 1), it is necessary for the wall transformer to exceed the LTC4257 UVLO turn-on requirement and limit the maximum voltage to 57V. This option provides input current limiting for the transformer, provides valid power good signaling and simplifies power priority issues. As long as the wall transformer applies power to the PD before the PSE, it will take priority and the PSE will not power up the PD because the wall power will corrupt the 25k signature. If the PSE is already powering the PD, the wall transformer power will be in parallel with the PSE. In this case, priority will be given to the higher supply voltage. If the wall transformer voltage is higher, the PSE should remove line voltage since no current will be

drawn from the PSE. On the other hand, if the wall transformer voltage is lower, the PSE will continue to supply power to the PD and the wall transformer power will not be used. Proper operation should occur in either scenario.

Auxiliary power can be applied after the LTC4257 as shown in option 2. In this configuration, the wall transformer does not need to exceed the LTC4257 turn-on UVLO requirement; however, it is necessary to include diode D9 to prevent the transformer from applying power to the LTC4257. The transformer voltage requirements will be governed by the needs of the PD switcher and may exceed 57V. However, power priority issues require more intervention. If the wall transformer voltage is below the PSE voltage, then priority will be given to the PSE power. The PD will draw power from the PSE while the transformer will sit unused. This configuration is not a problem in a PoE system. On the other hand, if the wall transformer voltage is higher than the PSE voltage, the PD will draw power from the transformer. In this situation, it is necessary to address the issue of power cycling that may occur if a PSE is present. The PSE will detect the PD and apply power. If the PD is being powered by the wall transformer, then the PD will not meet the minimum load requirement and the PSE will subsequently remove power. The PSE will again detect the PD and power cycling will start. With a transformer voltage above the PSE voltage, it is necessary to install a minimum load on the output of the LTC4257 to prevent power cycling. Refer to the LTC4257-1 data sheet for an alternative implementation of option 2 which uses the Signature Disable feature.

The third option also applies power after the LTC4257, while omitting diode D9. With the diode omitted, the transformer voltage is applied to the LTC4257 in addition to the load. For this reason, it is necessary to ensure that the transformer maintain the voltage between 44V and 57V to keep the LTC4257 in its normal operating range. The third option has the advantage of automatically disabling the 25k signature when the external voltage exceeds the PSE voltage.

APPLICATIONS INFORMATION

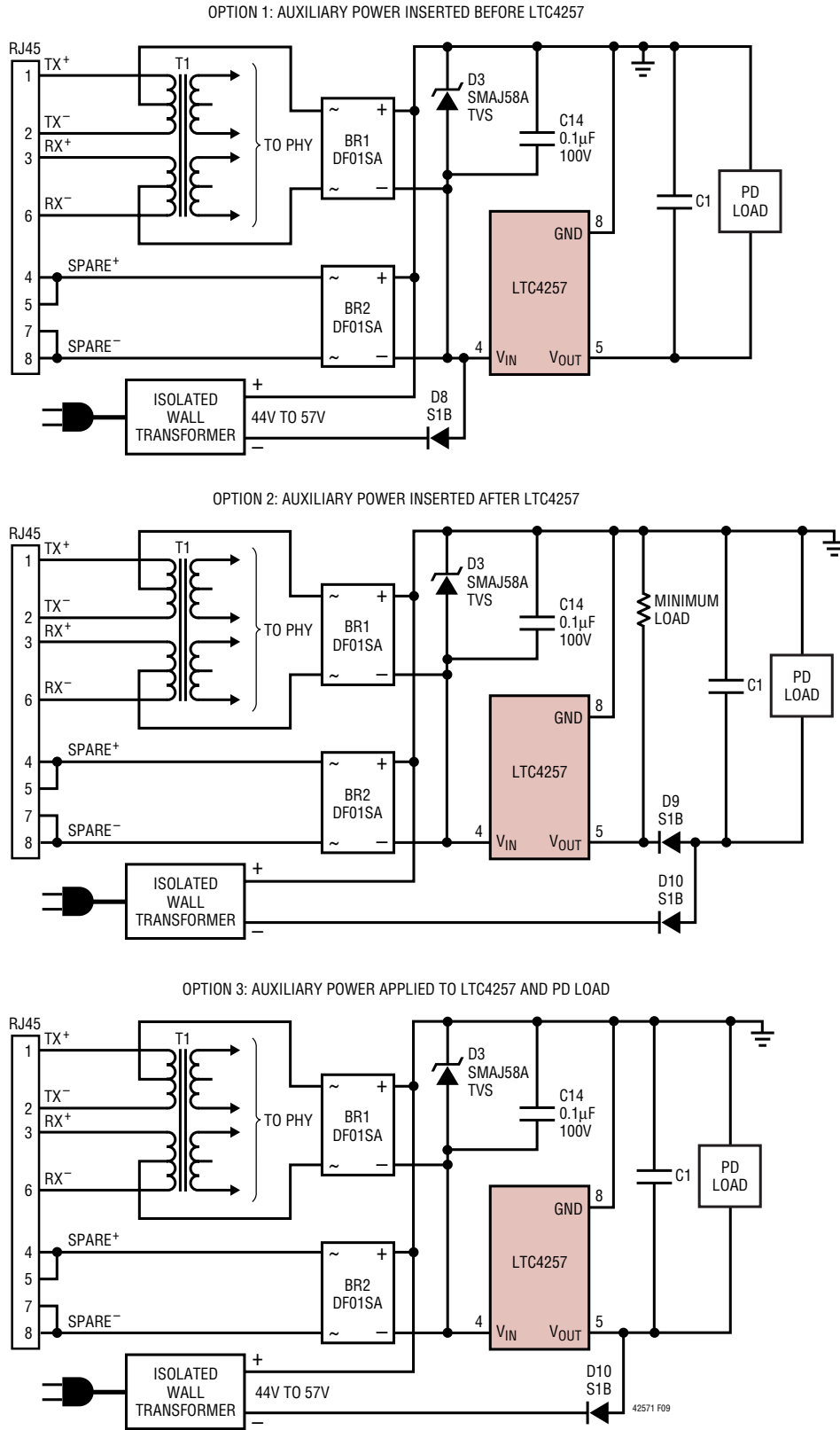

Figure 9. Auxiliary Power Source for PD

APPLICATIONS INFORMATION

Classification Resistor Selection (R_{CLASS})

IEEE 802.3af allows classifying PDs into four distinct classes with class 4 being reserved for future use (Table 2). An external resistor connected from R_{CLASS} to V_{IN} (Figure 3) sets the value of the classification current. The designer should determine which power category the PD falls into and then select the appropriate value of R_{CLASS} from Table 2. If a unique classification current is required, the value of R_{CLASS} can be calculated as:

$$R_{CLASS} = 1.237V / (I_{DESIRED} - I_{IN_CLASS})$$

where I_{IN_CLASS} is the LTC4257 IC supply current during classification and is given in the electrical specifications. The R_{CLASS} resistor must be 1% or better to avoid degrading the overall accuracy of the classification circuit. Resistor power dissipation will be 50mW maximum and is transient so heating is typically not a concern. In order to maintain loop stability, the layout should minimize capacitance at the R_{CLASS} node. The classification circuit can be disabled by floating the R_{CLASS} pin. The

R_{CLASS} pin should not be shorted to V_{IN} as this would force the LTC4257 classification circuit to attempt to source very large currents. In this case, the LTC4257 will quickly go into thermal shutdown.

Power Good Interface

The \overline{PWRGD} signal is controlled by a high voltage, open-drain transistor. Examples of active-high and active-low interface circuits for controlling the PD load are shown in Figure 10.

In some applications it is desirable to ignore intermittent power bad conditions. This can be accomplished by including capacitor C15 in Figure 10 to form a lowpass filter. With the components shown, power bad conditions less than about 200 μ s will be ignored. Conversely, in other applications it may be desirable to delay assertion of \overline{PWRGD} to the PD load. The \overline{PWRGD} signal can be delayed with the addition of capacitor C17 in Figure 10.

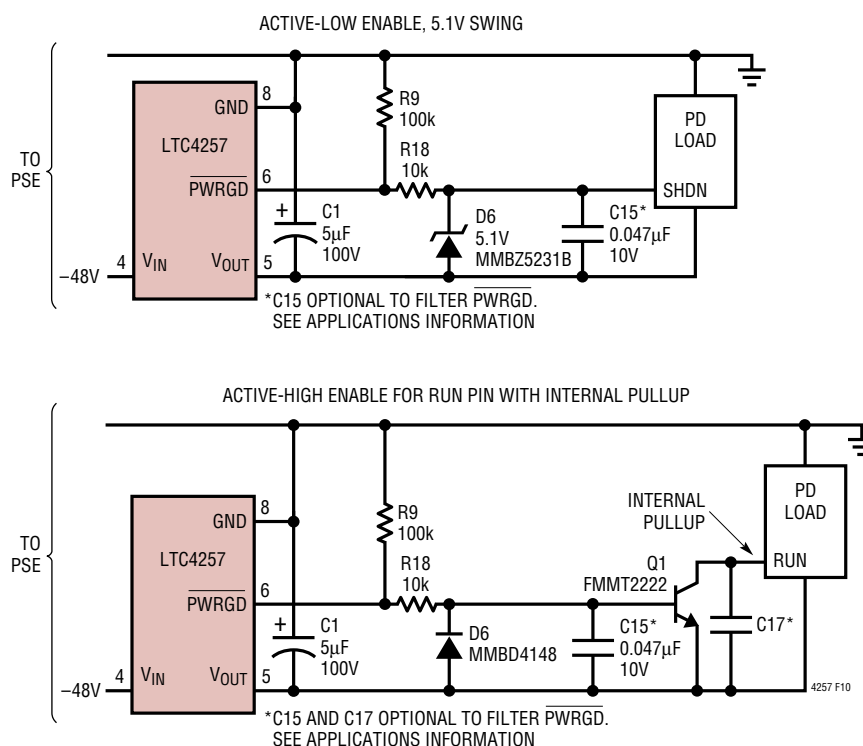

Figure 10. Power Good Interface Examples

APPLICATIONS INFORMATION

Load Capacitor

IEEE 802.3af requires that the PD maintain a minimum load capacitance of $5\mu\text{F}$. It is permissible to have a much larger load capacitor and the LTC4257 can charge very large load capacitors before thermal issues become a problem. However, the load capacitor must not be too large or the PD design may violate two IEEE 802.3af requirements. The LTC4257 goes into current limit at turn-on and charges the load capacitor with between 300mA and 400mA. The IEEE specification allows this level of inrush current for up to 50ms. Therefore, it is necessary that the PD complete charging of the capacitor within the 50ms time limit. With a maximum input voltage of -57V , these conditions limit the size of the load capacitor to $250\mu\text{F}$.

Very small output capacitors ($\leq 10\mu\text{F}$) will charge very quickly in current limit. The rapidly changing voltage at the output may reduce the current limit temporarily, causing the capacitor to charge at a somewhat reduced rate. Conversely, charging very large capacitors may cause the current limit to increase slightly. In either case, once the output voltage reaches its final value, the input current limit will be restored to its nominal value.

If the load capacitor is too large there can be an additional problem with inadvertent power shutdown by the PSE. Consider the following scenario. If the PSE is running at

-57V (maximum allowed) and the PD has been detected and powered up, the load capacitor will be charged to nearly -57V . If for some reason the PSE voltage suddenly is reduced to -44V (minimum allowed), the input diodes will reverse bias and PD power will be supplied solely by the load capacitor. Depending on the size of the load capacitor and the DC load of the PD, the PD will not draw any power from the PSE for a period of time. If this period of time exceeds the IEEE 802.3af 300ms disconnect delay, the PSE may remove power from the PD. For this reason, it is necessary to evaluate the load capacitance and load current to ensure that inadvertent shutdown cannot occur.

Maintain Power Signature

In an IEEE 802.3af system, the PSE uses the *maintain power signature* (MPS) to determine if a PD continues to require power. The MPS requires the PD to periodically draw at least 10mA and also have an AC impedance less than $26.25\text{k}\Omega$ in parallel with $0.05\mu\text{F}$. The PD application circuits shown in this data sheet meet the requirements necessary to maintain power. If either the DC current is less than 10mA or the AC impedance is above $26.25\text{k}\Omega$, the PSE might disconnect power. The DC current must be less than 5mA and the AC impedance must be above $2\text{M}\Omega$ to guarantee power will be removed.

APPLICATIONS INFORMATION

Layout

The LTC4257 is relatively immune to layout problems. Excessive parasitic capacitance on the R_{CLASS} pin should be avoided. If using the DD package, include an electrically isolated heat sink to which the exposed pad on the bottom of the package can be soldered. For optimal thermal performance, make the heat sink as large as possible. Voltages in a PD can be as large as $-57V$, so high voltage layout techniques should be employed.

The load capacitor connected between Pins 5 and 8 of the LTC4257 can store significant energy when fully charged. The design of a PD must ensure that this energy is not inadvertently dissipated in the LTC4257. The polarity-protection diode(s) prevent an accidental short on the

cable from causing damage. However, if the V_{IN} pin is shorted to the GND pin inside the PD while the load capacitor is charged, current will flow through the parasitic body diode of the internal MOSFET and may cause permanent damage to the LTC4257.

Input Surge Suppression

The LTC4257 is specified to operate with an absolute maximum voltage of $-100V$ and is designed to tolerate brief overvoltage events. However, the pins that interface to the outside world (primarily V_{IN} and GND) can routinely see peak voltages in excess of $10kV$. To protect the LTC4257, it is highly recommended that a transient voltage suppressor be installed between the bridge and the LTC4257 (D3 in Figure 2).

TYPICAL APPLICATION

Figure 11: PD Power Interface with 3.3V, 2.8A High Efficiency Isolated Power Supply

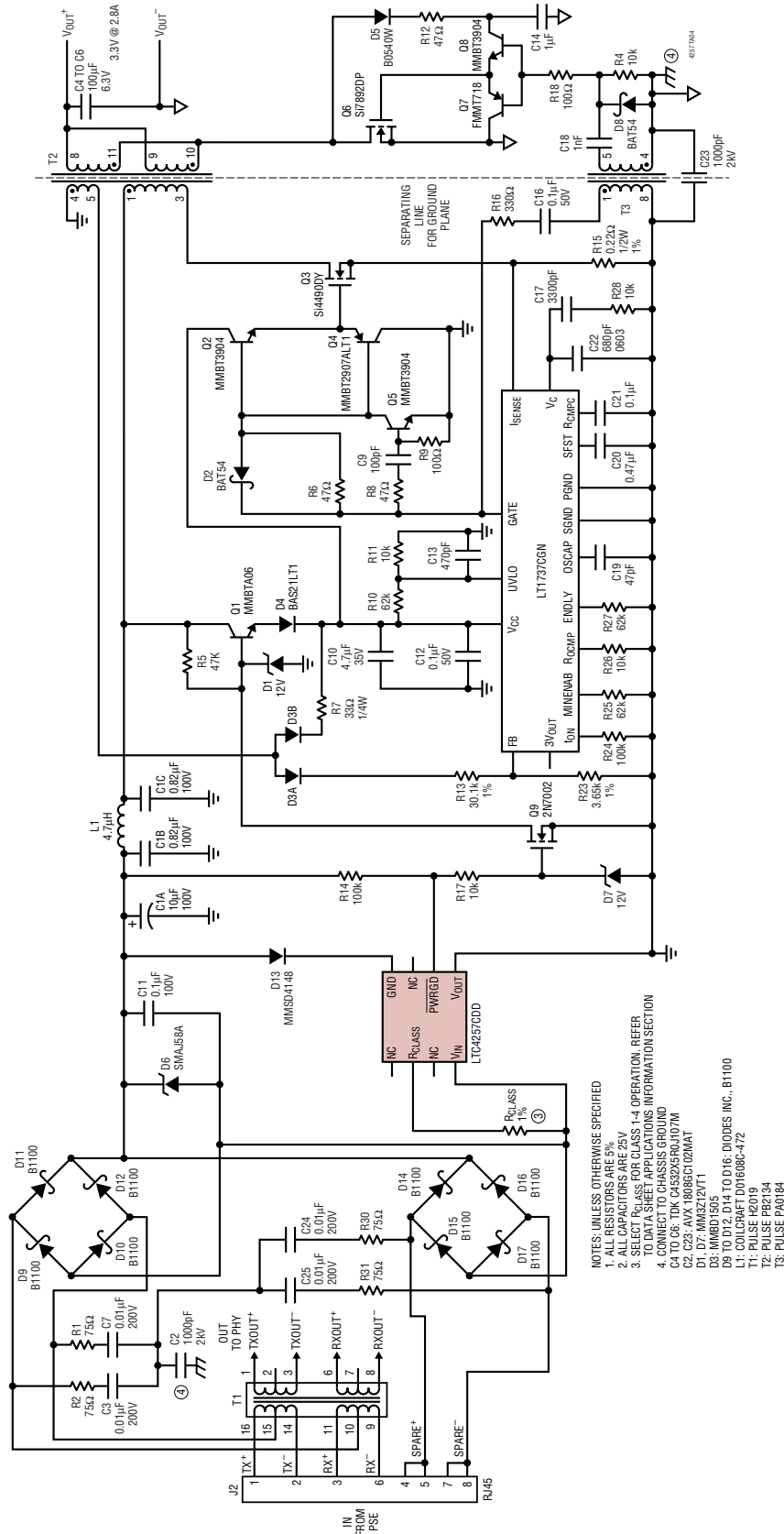

PACKAGE DESCRIPTION

S8 Package 8-Lead Plastic Small Outline (Narrow .150 Inch) (Reference LTC DWG # 05-08-1610)

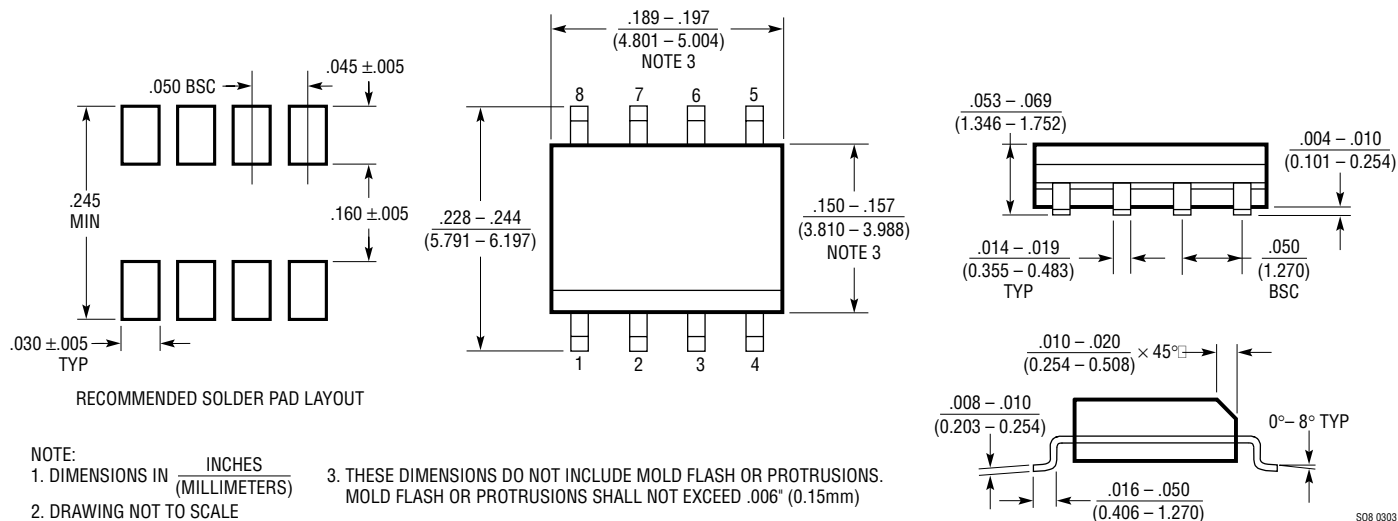

DD Package 8-Lead Plastic DFN (3mm × 3mm) (Reference LTC DWG # 05-08-1698)

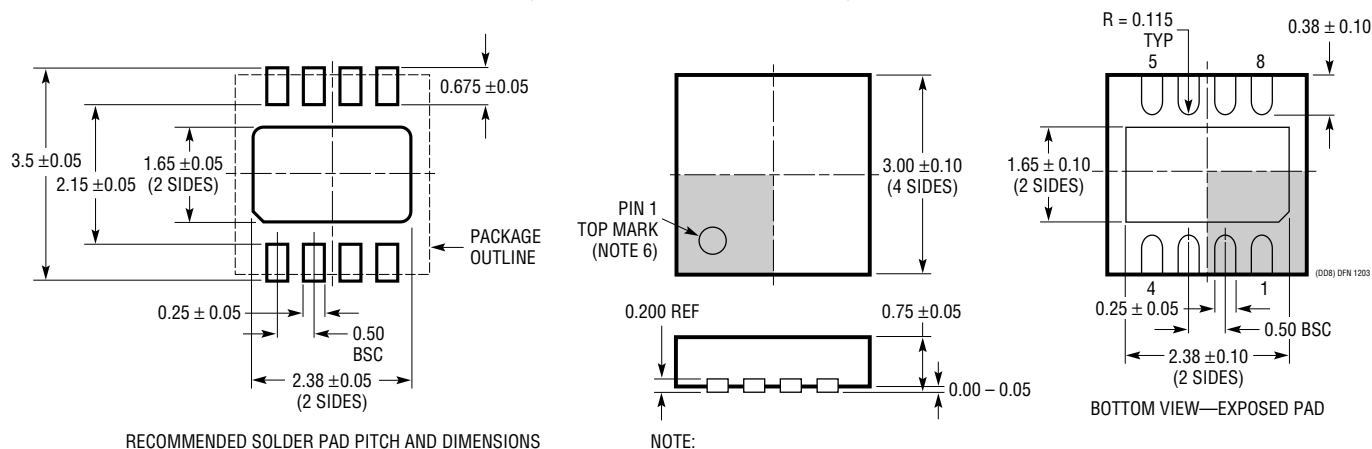

Looking for pricing, stock, or lifecycle information?

Click below to explore more details on WIN SOURCE:

 [View LTC4257CDD#PBF on WIN SOURCE](#)

 [Analog Devices Inc. Information](#)

Optimize Your Supply Chain with WIN SOURCE Solutions

-  Global Sourcing Solution
-  Obsolete Management
-  Cost Control Management
-  Shortage Management
-  Alternative Solution
-  Excess Inventory Management