



# THE DATASHEET OF DC2836A



# LT7182S

## Dual Channel 6A, 20V, PolyPhase Step-Down Silent Switcher with Digital Power System Management

### DESCRIPTION

Demonstration Circuit 2836A is a dual-output PolyPhase® DC/DC synchronous step-down regulator with 4V to 20V input range featuring [LT®7182S](#). Each output can supply 6A continuous/9A maximum transient load current. LT7182S is a dual 6A monolithic step-down regulator. The second-generation Silent Switcher® structure is incorporated into LT7182S to minimize EMI and reduce PCB layout sensitivity. It also integrates digital power system management function allowing for programmability and telemetry with a PMBus/I<sup>2</sup>C compliant serial interface. Please see LT7182S data sheet for more detailed information.

The demonstration circuit 2836A runs at 1MHz to minimize solution size. The peak efficiency at 12V input is 83.2% for 1.2V rail and 91.1% for 3.3V rail. The IC temperature rise is 70°C when both channels run at full load, 6A each, at 1MHz.

The demo board has EMI filters installed for both channels. The conducted and radiated EMI performances of the board (with EMI filters) are shown in Figure 2. The red lines in Figure 2 are CISPR25 CLASS 5 limit.

DC2836A powers up to default settings and produces power based on configuration resistors without the need for any serial bus communication. This allows easy evaluation of the DC/DC converter. To fully explore the power system management features of the part, download the GUI software LTpowerPlay® onto your PC and use ADI's I<sup>2</sup>C/SMBus/PMBus dongle DC1613A to connect to the board. LTpowerPlay allows the user to reconfigure the part on the fly and store the configuration in EEPROM, view telemetry of voltage, current, temperature and fault status.

#### GUI Download

The software can be downloaded from: [LTpowerPlay](#)

The LT7182S data sheet gives a complete description of the part, operation and application information. The data sheet must be read in conjunction with this demo manual for DC2836A.

For more details and instructions of LTpowerPlay, please refer to LTpowerPlay GUI for LT7182S Quick Start Guide.

**[Design files for this circuit board are available.](#)**

All registered trademarks and trademarks are the property of their respective owners.

### PERFORMANCE SUMMARY Specifications are at T<sub>A</sub> = 25°C

SYMBOL	PARAMETER	CONDITIONS	MIN	TYP	MAX	UNITS
V <sub>IN</sub>	Input Voltage Range		4		20	V
V <sub>OUT0</sub>	Output0 Voltage			1.2		V
I <sub>OUT0</sub>	Maximum Output0 Current		9			A
V <sub>OUT1</sub>	Output1 Voltage			3.3		V
I <sub>OUT1</sub>	Maximum Output1 Current		9			A
f <sub>SW</sub>	Switching Frequency		0.925	1	1.075	MHz
EFE	Efficiency at DC	V <sub>IN</sub> = 12V, I <sub>OUT0</sub> = 3A, I <sub>OUT1</sub> = 0A V <sub>IN</sub> = 12V, I <sub>OUT1</sub> = 3A, I <sub>OUT0</sub> = 0A		83.2 91.1		% %

## QUICK START PROCEDURE

DC2836A is easy to set up to evaluate the performance of the LT7182S. Refer to Figure 3 for proper measurement equipment setup and follow the procedure below:

NOTE: When measuring the input or output voltage ripple, care must be taken to avoid a long ground lead on the oscilloscope probe. See Figure 5 for the proper scope technique.

1. Set an input power supply that is capable of 20V/18A. Then turn off the supply.
2. With power off, connect the supply to the input terminals VEMI and GND. Set default jumper position: SW1: ON; SW2: ON
3. Turn on the power at the input.

NOTE: Make sure that the input voltage never exceeds 20V.

4. Check for the proper output voltages of 1.2V  $\pm$ 0.5% (1.194V ~ 1.206V) and 3.3V  $\pm$ 0.5% (3.283V ~ 3.317V). Turn off the power at the input.
5. Once the proper output voltage is established, connect variable loads capable of sinking 6A at 1.2V and 3.3V to the output terminals VOUT0/VOUT1 and GND. Set the current for 0A.

- a. If efficiency measurements are desired, ammeters can be put in series with the output loads to measure the DC2836A's output currents.
- b. Voltmeters can be placed across the output terminals to get accurate output voltage measurements.

6. Turn on the power at the input.

NOTE: If there is no output, temporarily disconnect the load to make sure that the load is not set too high.

7. Once the proper output voltages are established again, adjust the load and/or input within the operating range and observe the output voltage regulation, ripple voltage, efficiency and other desired parameters.
8. Connect the dongle and control the output voltages from the GUI. See LTpowerPlay GUI for the LT7182S Quick Start Guide for details.

NOTE: When measuring the output or input voltage ripple, do not use the long ground lead on the oscilloscope probe. See Figure 4 for the proper scope probe technique. Short, stiff leads need to be soldered to the (+) and (-) terminals of an output capacitor. The probe's ground ring needs to touch the (-) lead and the probe tip needs to touch the (+) lead.

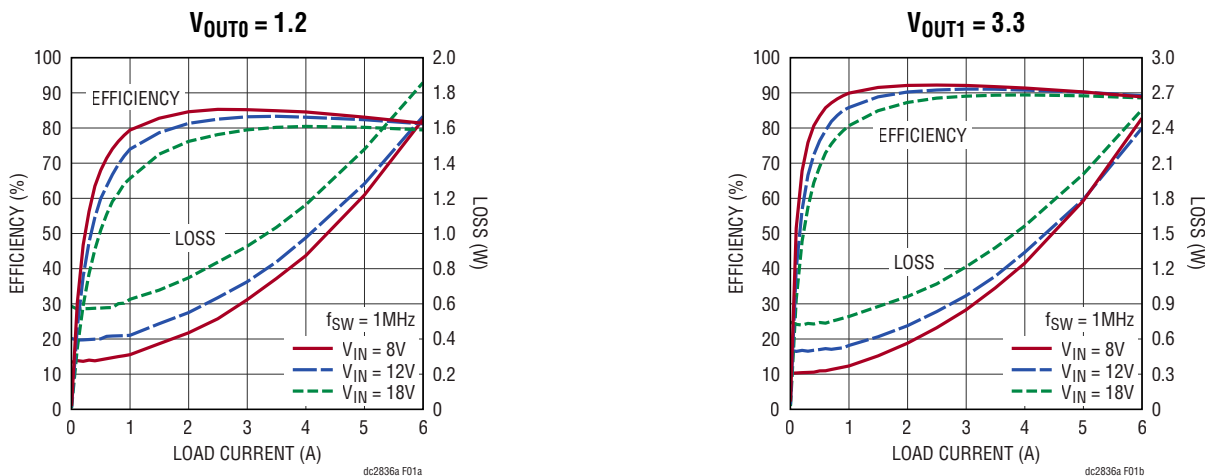
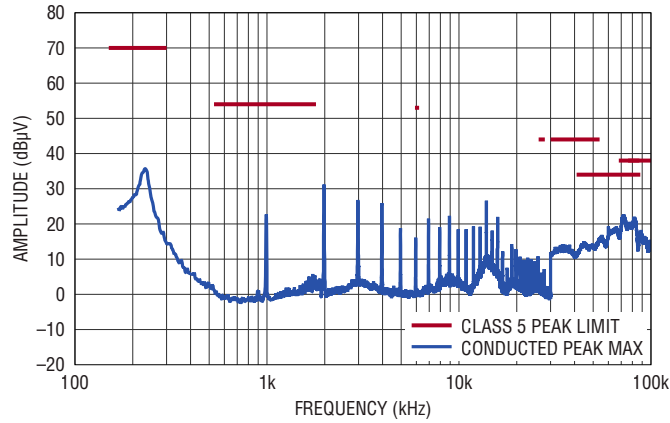

Figure 1. Efficiency vs Load Current at 1MHz Switching Frequency

**QUICK START PROCEDURE**

**Conducted EMI Performance (CISPR25 Conducted Emission Test with Class 5 Peak Limits)**



DC2836A DEMO BOARD  
 (WITH EMI FILTER INSTALLED)  
 14V INPUT TO 1.2V OUTPUT0 PLUS 3.3V OUTPUT1 AT 6A  
 $f_{SW} = 1\text{MHz}$

dc2836a F02a

**Radiated EMI Performance (CISPR25 Radiated Emission Test with Class 5 Peak Limits)**

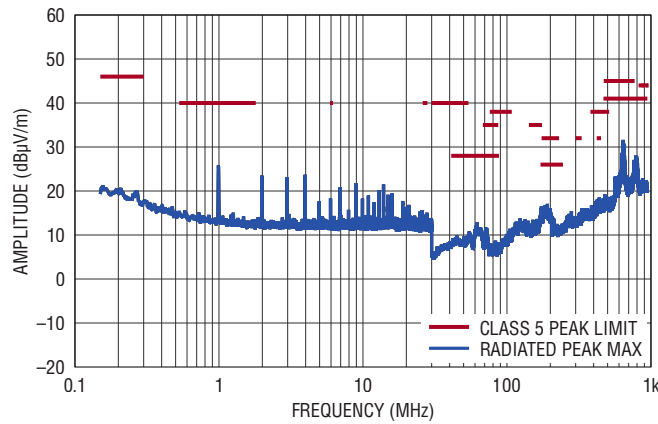

DC2836A DEMO BOARD  
 (WITH EMI FILTER INSTALLED)  
 14V INPUT TO 1.2V OUTPUT0 PLUS 3.3V OUTPUT1 AT 6A  
 $f_{SW} = 1\text{MHz}$

dc2836a F02b

**Figure 2. Demo Circuit 2836A EMI Performance in CISPR25 Conducted and Radiated Emission Test ( $V_{IN} = 14\text{V}$ ,  $V_{OUT0} = 1.2\text{V}$ ,  $I_{OUT0} = 6\text{A}$ ,  $V_{OUT1} = 3.3\text{V}$ ,  $I_{OUT1} = 6\text{A}$ , 1MHz Switching Frequency)**

## QUICK START PROCEDURE

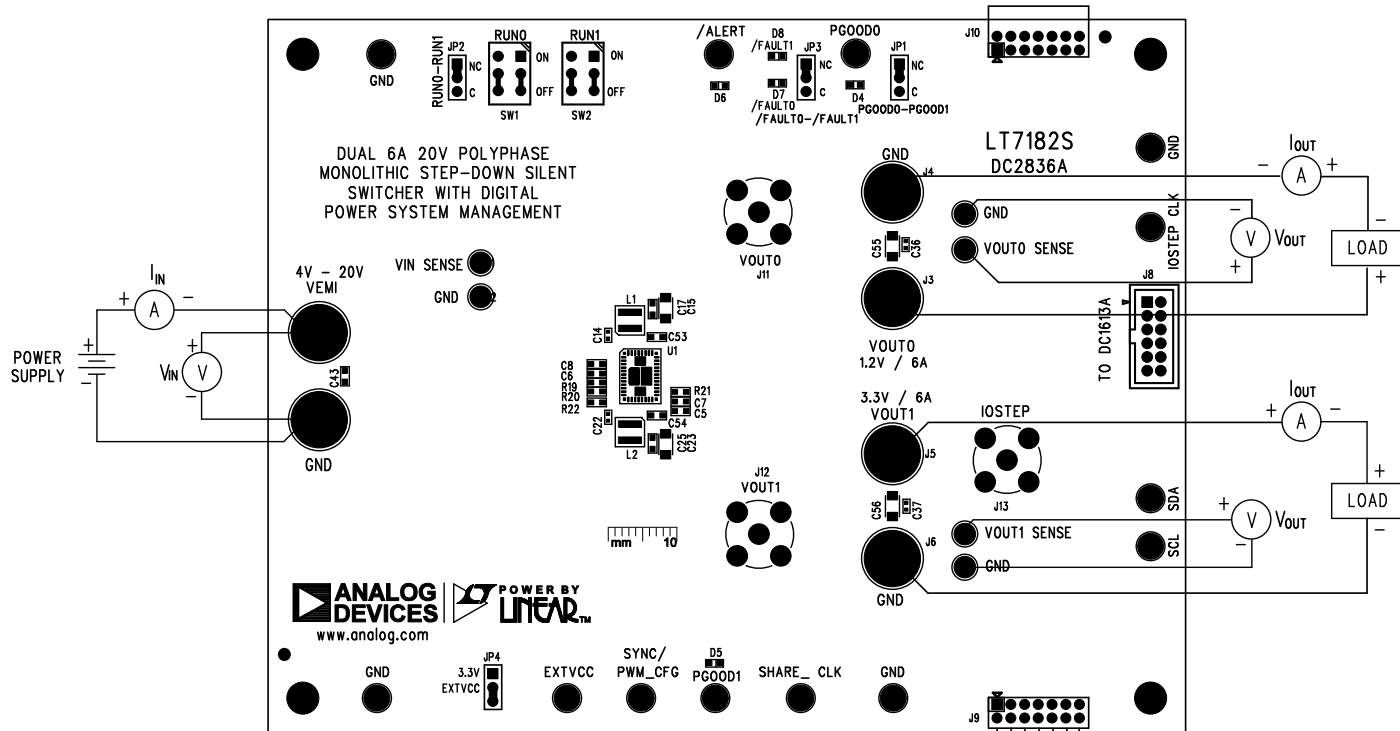
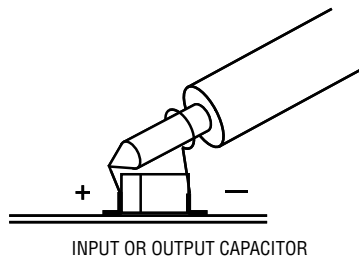

Figure 3. Proper Measurement Equipment Setup

**QUICK START PROCEDURE**

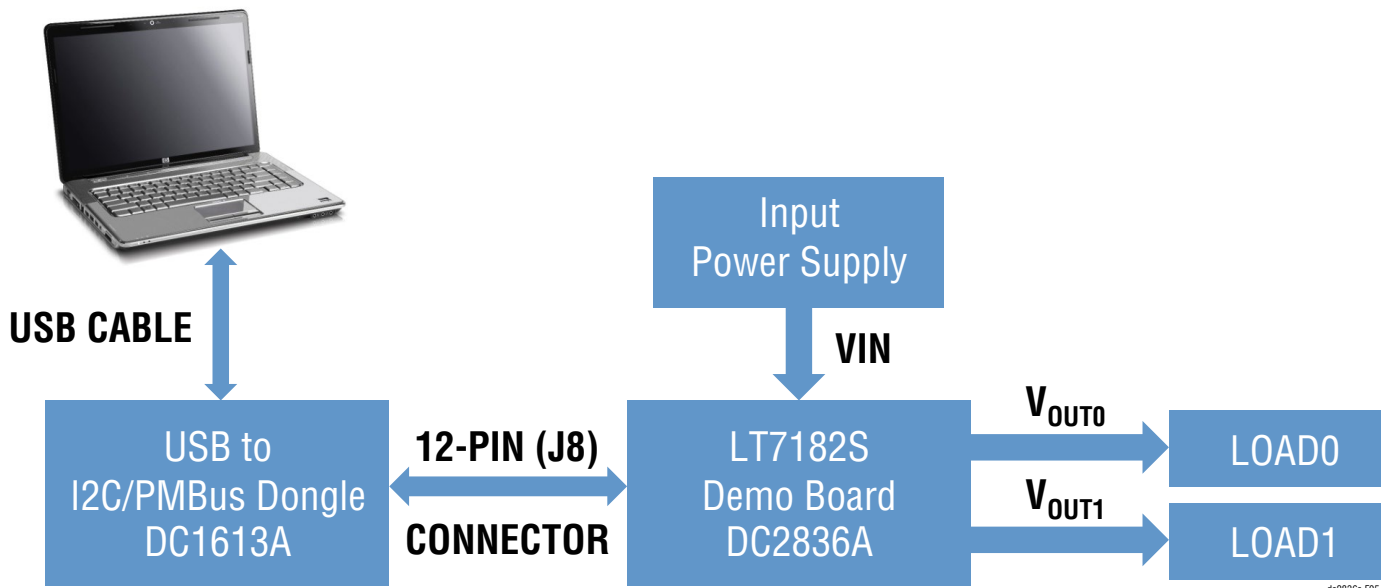

**Figure 4. Measuring Input or Output Ripple**

**Connecting a PC to DC2836A**

You can use a PC to reconfigure the power management features of the LT7182S such as: nominal  $V_{OUT}$ ,

margin set points, OV/UV limits, temperature fault limits, sequencing parameters, the fault log, fault responses, GPIOs and other functionalities. The DC1613A dongle may be plugged when  $V_{IN}$  is present.



**Figure 5. Demo Setup with PC**

## LTpowerPlay SOFTWARE GUI

LTpowerPlay is a powerful Windows based development environment that supports Linear Technology power system management ICs and  $\mu$ Modules. The software supports a variety of different tasks. You can use LTpowerPlay to evaluate Linear Technology ICs by connecting to a demo board system. LTpowerPlay can also be used in an offline mode (with no hardware present) in order to build a multichip configuration file that can be saved and reloaded at a later time. LTpowerPlay provides unprecedented diagnostic and debug features. It becomes a valuable diagnostic tool during board bring-up to program or tweak the power management scheme in a system, or to diagnose

power issues when bringing up rails. LTpowerPlay utilizes the DC1613A USB-to-SMBus controller to communicate with one of many potential demo system, or a customer board. The software also provides an automatic update feature to keep the software current with the latest set of device drivers and documentation. The LTpowerPlay software can be downloaded from:

[LTpowerPlay | Analog Devices](#)

To access technical support documents for LTC Digital Power Products visit the LTpowerPlay Help menu. Online help also available through the LTpowerPlay.

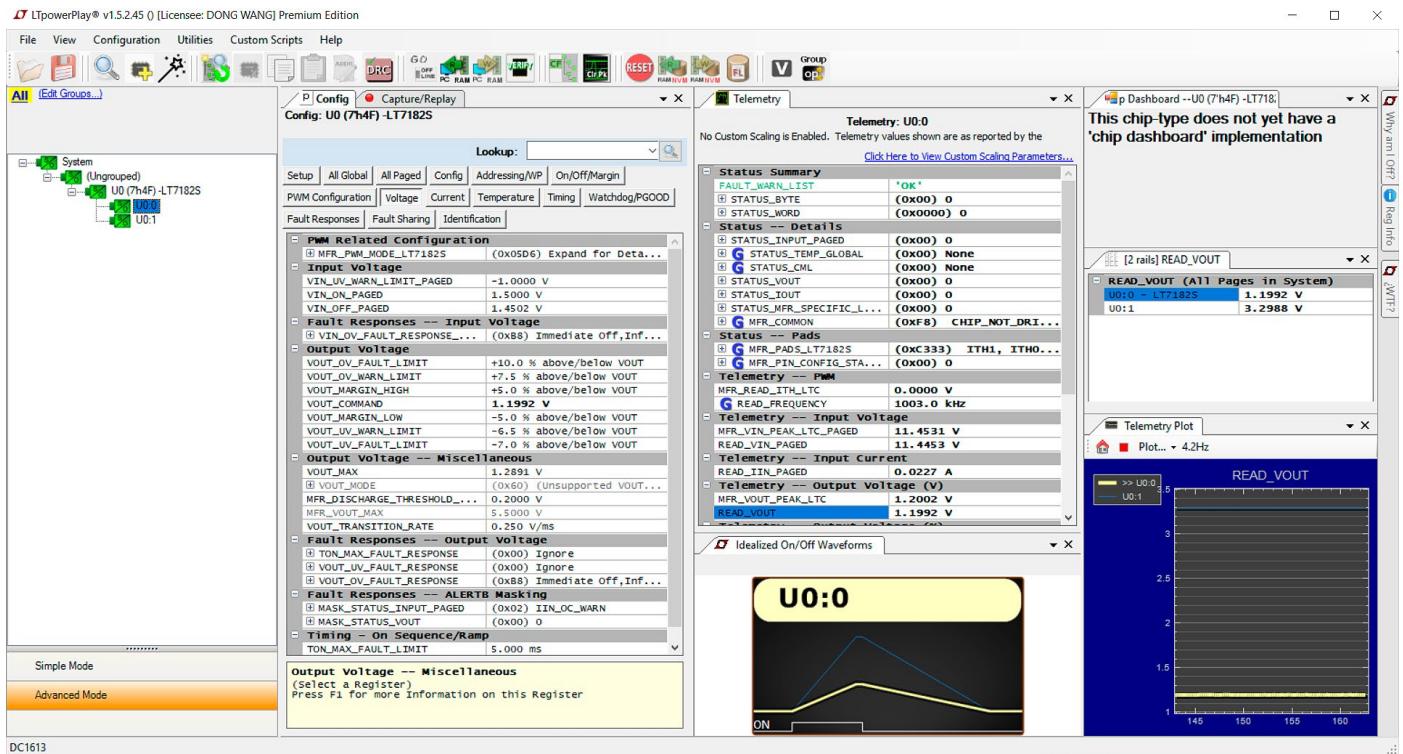

Figure 6. LTpowerPlay Main Interface

## LTpowerPlay QUICK START PROCEDURE

The following procedure describes how to use LTpowerPlay to monitor and change the settings of LT7182S.

1. Download and install the LTPowerPlay GUI:

[LTpowerPlay | Analog Devices](#)

2. Launch the LTpowerPlay GUI.

- a. The GUI should automatically identify the DC2836A. The system tree on the left hand side should look like this:

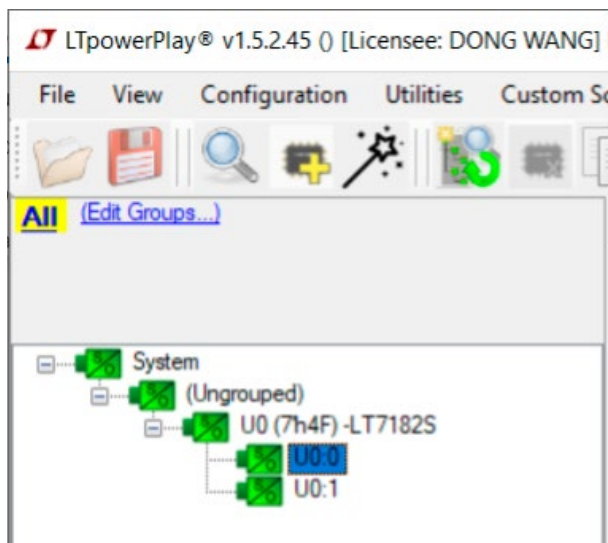

- b. A green message box shows for a few seconds in the lower left hand corner, confirming that LT7182S is communicating:

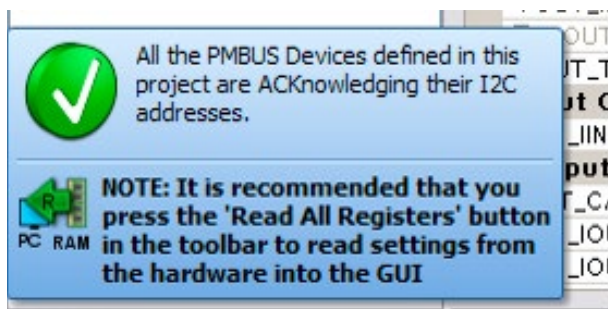

- c. In the Toolbar, click the R (RAM to PC) icon to read the RAM from the LT7182S. This reads the configuration from the RAM of LT7182S and loads it into the GUI.



- d. If you want to change the output voltage to a different value, like 1.5V. In the Config tab, type in 1.5 in the VOUT\_COMMAND box, like this:

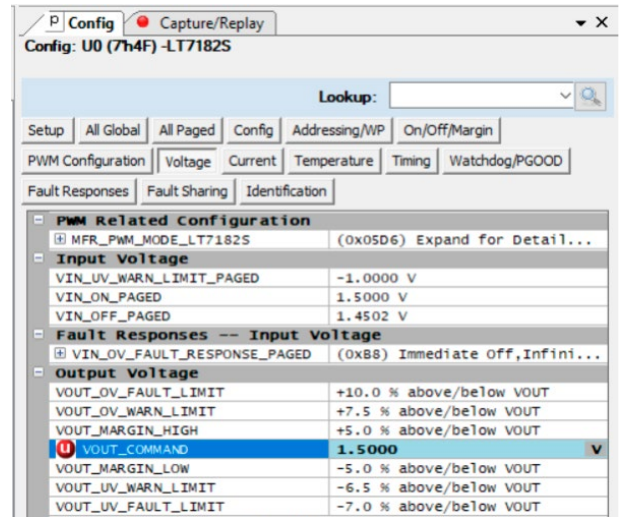

Then, click the W (PC to RAM) icon to write these register values to the LT7182S. After finishing this step, you will see the output voltage will change to 1.5V.



If the write is successful, you will see the following message:

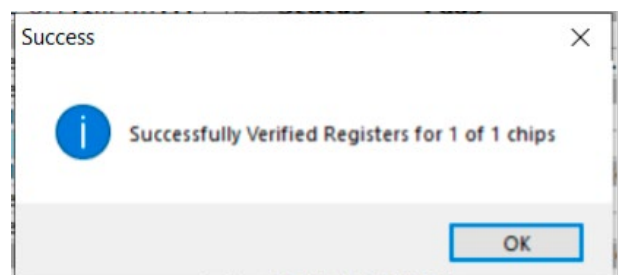

- e. You can save the changes into the NVM. In the toolbar, click RAM to NVM button, as following



- f. Save the demo board configuration to a (\*.proj) file. Click the Save icon and save the file. Name it whatever you want.

# DEMO MANUAL DC2836A

## PARTS LIST

ITEM	QTY	REFERENCE	PART DESCRIPTION	MANUFACTURER/PART NUMBER
<b>Required Circuit Components</b>				
1	3	C5, C6, C8	CAP, 10 $\mu$ F, X6S, 10V, 10%, 0603	MURATA, ZRB18AC81A106KE01L
2	1	C7	CAP, 1 $\mu$ F, X7R, 16V, 10%, 0603	MURATA, GRM188R71C105KA12D
3	2	C14, C22	CAP, 0.1 $\mu$ F, X7R, 25V, 10%, 0402	MURATA, GRM155R71E104KE14
4	4	C15, C23, C55, C56	CAP, 100 $\mu$ F, X5R, 6.3V, 10%, 1206	MURATA, GRM31CR60J107KE39L
5	2	C17, C25	CAP, 10 $\mu$ F, X5R, 10V, 10%, 0603	MURATA, GRM188R61A106KAALD
6	2	C36, C37	CAP, 1 $\mu$ F, X5R, 35V, 10%, 0402	MURATA, GRM155R6YA105KE11D
7	2	C53, C54	CAP, 4.7 $\mu$ F, X6S, 25V, 10%, 0603	MURATA, GRM188C81E475KE11D
8	1	L1	IND., 0.47 $\mu$ H, 21.2A, 3.4m $\Omega$	COILCRAFT, XGL4030-471MEC
9	1	L2	IND., 1.2 $\mu$ H, 12.2A, 9.4m $\Omega$	COILCRAFT, XGL4030-122MEC
10	6	R2, R3, R4, R7, R8, R9	RES., 10k, 1%, 1/10W, 0603	VISHAY, CRCW060310K0FKEA
11	1	R19	RES., 51.1k, 1%, 1/10W, 0603	VISHAY, CRCW060351K1FKEA
12	1	R20	RES., 107k, 1%, 1/10W, 0603	VISHAY, CRCW0603107KFKEA
13	1	R21	RES., 80.6k, 1%, 1/10W, 0603	VISHAY, CRCW060380K6FKEA
14	1	U1	IC, REGULATOR, LQFN-40	ANALOG DEVICES, LT7182SRV#PBF
<b>Additional Demo Board Circuit Components</b>				
1	1	C1	CAP, 1 $\mu$ F, X5R, 50V, 10%, 0603	MURATA, GRM188R61H105KAALD
2	1	C2	CAP, 0.01 $\mu$ F, X7R, 25V, 10%, 0603	TDK, C1608X7R1E103K080AA
3	1	C3	CAP, 100 $\mu$ F, ALUM, 35V	PANASONIC, EEHZK1V101XP
4	1	C4	CAP, 4.7 $\mu$ F, X7R, 10V, 10%, 0805	TDK, C2012X7R1A475K085AC
5	1	C57	CAP, 10 $\mu$ F, X6S, 10V, 10%, 0603	MURATA, ZRB18AC81A106KE01L
6	0	C16, C24	CAP, OPTION, 7343	
7	0	C19, C20, C27, C28	CAP, OPTION, 0603	
8	2	C29, C30	CAP, 0.01 $\mu$ F, X5R, 25V, 10%, 0603	AVX, 06033D103KAT2A
9	1	C31	CAP, 0.1 $\mu$ F, X7R, 10V, 20%, 0603	AVX, 0603ZC104MAT2A
10	2	C32, C33	CAP, 1 $\mu$ F, X5R, 10V, 10%, 0603	MURATA, GRM188R61A105KA61D
11	2	C34, C35	CAP, 0.01 $\mu$ F, X5R, 50V, 10%, 0603	AVX, 06035D103KAT2A
12	4	C38, C39, C40, C41	CAP, 0.1 $\mu$ F, X7R, 50V, 10%, 0402	MURATA, GCM155R71H104KE02D
13	2	C42, C44	CAP, 10 $\mu$ F, X5R, 50V, 10%, 1210	TDK, C3225X5R1H106K250AB
14	1	C43	CAP, 1 $\mu$ F, X5R, 50V, 10%, 0603	TAIYO YUDEN, UMK107ABJ105KAHT
15	3	C50, C51, C52	CAP, 4.7 $\mu$ F, X5R, 25V, 10%, 0603	MURATA, GRM188R61E475KE15D
16	0	D1, D2	DIODE, OPTION, SOD-323	
17	2	D4, D5	LED, GREEN, DIFFUSED, 0603	BROADCOM INC., HSMG-C190
18	3	D6, D7, D8	LED, RED, DIFFUSED, 0603	BROADCOM INC., HSMH-C190
19	1	FB1	FERRITE BEAD, 100 $\Omega$ , 1812	WURTH ELEKTRONIK, 74279226101
20	1	L3	IND., 0.47 $\mu$ H, 6.8A, 14m $\Omega$	WURTH ELEKTRONIK, 744373240047
21	2	Q2, Q3	MOSFET, N-CH, SOT-23-3	VISHAY, 2N7002K-T1-GE3
22	1	Q4	MOSFET, N-CH, DPAK	VISHAY, SUD50N04-8M8P-4GE3

## PARTS LIST

ITEM	QTY	REFERENCE	PART DESCRIPTION	MANUFACTURER/PART NUMBER
23	11	R1, R11, R12, R14, R16, R18, R23, R25, R35, R38, R41	RES., 0 $\Omega$ , 1/10W, 0603	VISHAY, CRCW06030000Z0EA
24	5	R5, R6, R37, R39, R56	RES., 10k, 1%, 1/10W, 0603	VISHAY, CRCW060310K0FKEA
25	0	R13, R15, R22, R24, R26, R27, R28, R33, R34, R36, R40, R42, R43, R49, R50, R62, R63, R67	RES., OPTION, 0603	
26	0	R29, R30	RES., OPTION, 2512	
27	2	R44, R45	RES., 10 $\Omega$ , 5%, 1/10W, 0603	VISHAY, CRCW060310R0JNEA
28	2	R46, R61	RES., 4.99k, 1%, 1/10W, 0603	VISHAY, CRCW06034K99FKEA
29	0	R48	RES., OPTION, 1206	
30	5	R51, R52, R64, R65, R66	RES., 866 $\Omega$ , 1%, 1/10W, 0603	VISHAY, CRCW0603866RFKEA
31	1	R53	RES., 0 $\Omega$ , 1W, 2010	VISHAY, CRCW20100000Z0EFHP
32	0	R54	RES., OPTION, 2010	
33	1	R57	RES., 0.01 $\Omega$ , 1%, 1W, 2512	VISHAY, WSL2512R0100FEA
34	1	U2	IC, EEPROM, 2Kb (256x8), TSSOP-8	MICROCHIP, 24LC025-I/ST
35	1	U3	IC, IDEAL DIO, 10DFN	ANALOG DEVICES, LTC4413EDD#PBF
36	1	U4	IC, LDO, TSOT23-5	ANALOG DEVICES, LT1761ES5-3.3#PBF

### Hardware: For Demo Board Only

1	6	E1, E2, J3-J6	BANANA JACK, FEMALE	KEYSTONE, 575-4
2	13	E12-E21, E40, E47, E48	TEST POINT, TURRET, 0.094"	MILL-MAX, 2501-2-00-80-00-00-07-0
3	6	E41-E46	TEST POINT, TURRET, 0.064"	MILL-MAX, 2308-2-00-80-00-00-07-0
4	1	J8	CONN., HDR, MALE, 2x6, 2mm	AMPHENOL, 98414-G06-12ULF
5	1	J9	CONN., HDR, MALE, 2x7, 2mm	MOLEX, 0877601416
6	1	J10	CONN., HDR, FEMALE, 2x7, 2mm	SULL. CONN. SOLU., NPPN072FJFN-RC
7	3	J11, J12, J13	CONN., BNC, 50 $\Omega$	AMPHENOL RF, 112404
8	4	JP1, JP2, JP3, JP4	CONN., HDR, MALE, 1x3, 2mm	WURTH ELEKTRONIK, 62000311121
9	4	MP1, MP2, MP3, MP4	STANDOFF, NYLON, SNAP-ON, 0.50"	KEYSTONE, 8833
10	2	SW1, SW2	SWITCH, SLIDE, DPDT, 0.3A, 6VDC, PTH	C&K, JS202011CQN
11	4	XJP1, XJP2, XJP3, XJP4	CONN., SHUNT, FEMALE, 2 POS, 2mm	WURTH ELEKTRONIK, 60800213421

# DEMO MANUAL DC2836A

## SCHEMATIC DIAGRAM

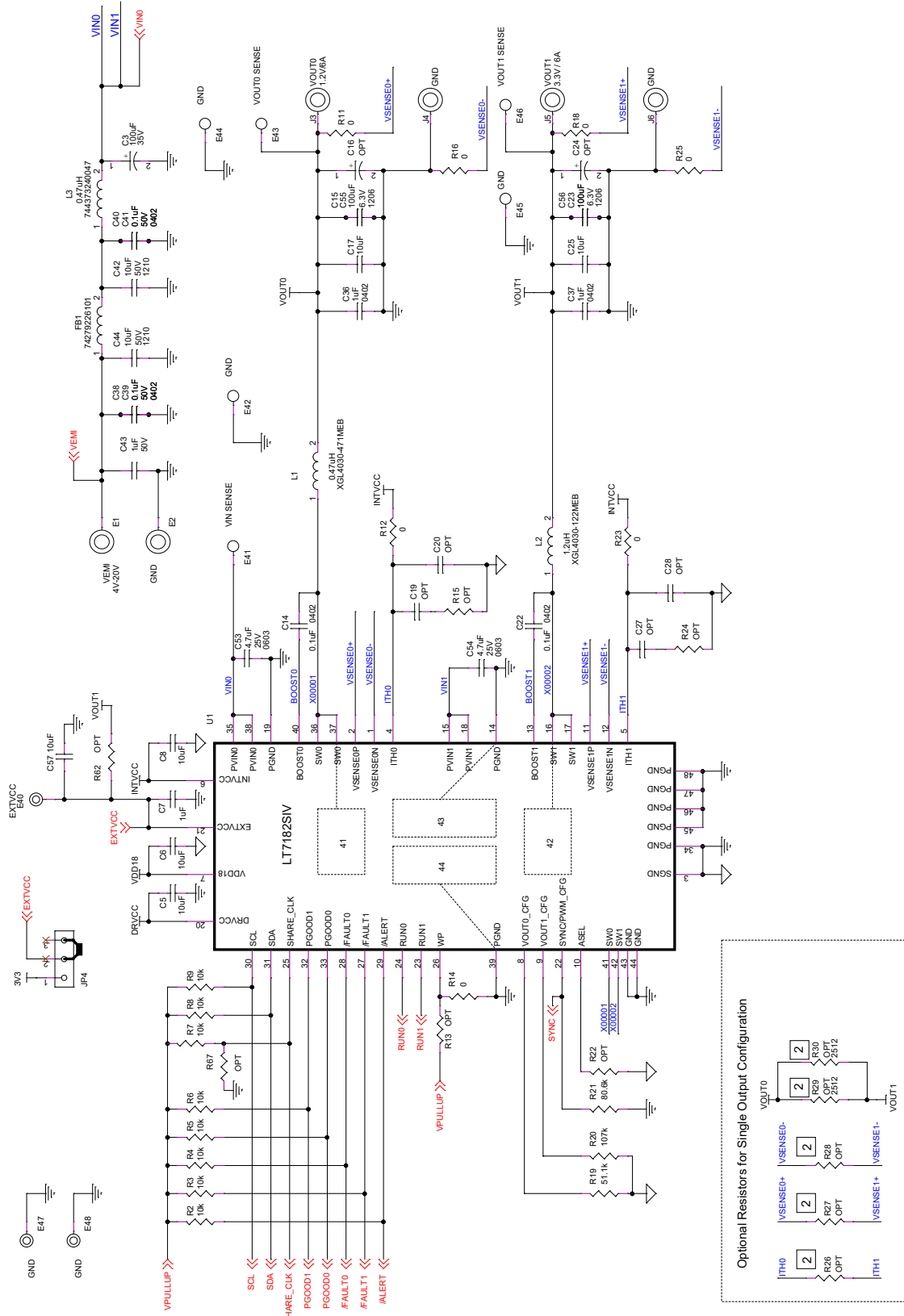

NOTE: UNLESS OTHERWISE SPECIFIED  
 1. ALL RESISTORS AND CAPACITORS ARE 0603.  
 2. FOR SINGLE OUTPUT CONFIGURATION.

**SCHEMATIC DIAGRAM**

ALL PARTS ON THIS PAGE ARE FOR DEMO ONLY, NOT NEEDED IN CUSTOMER DESIGN

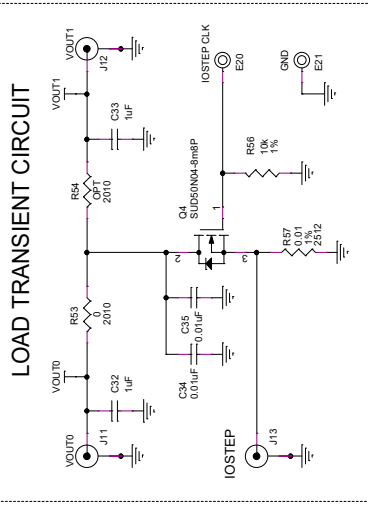
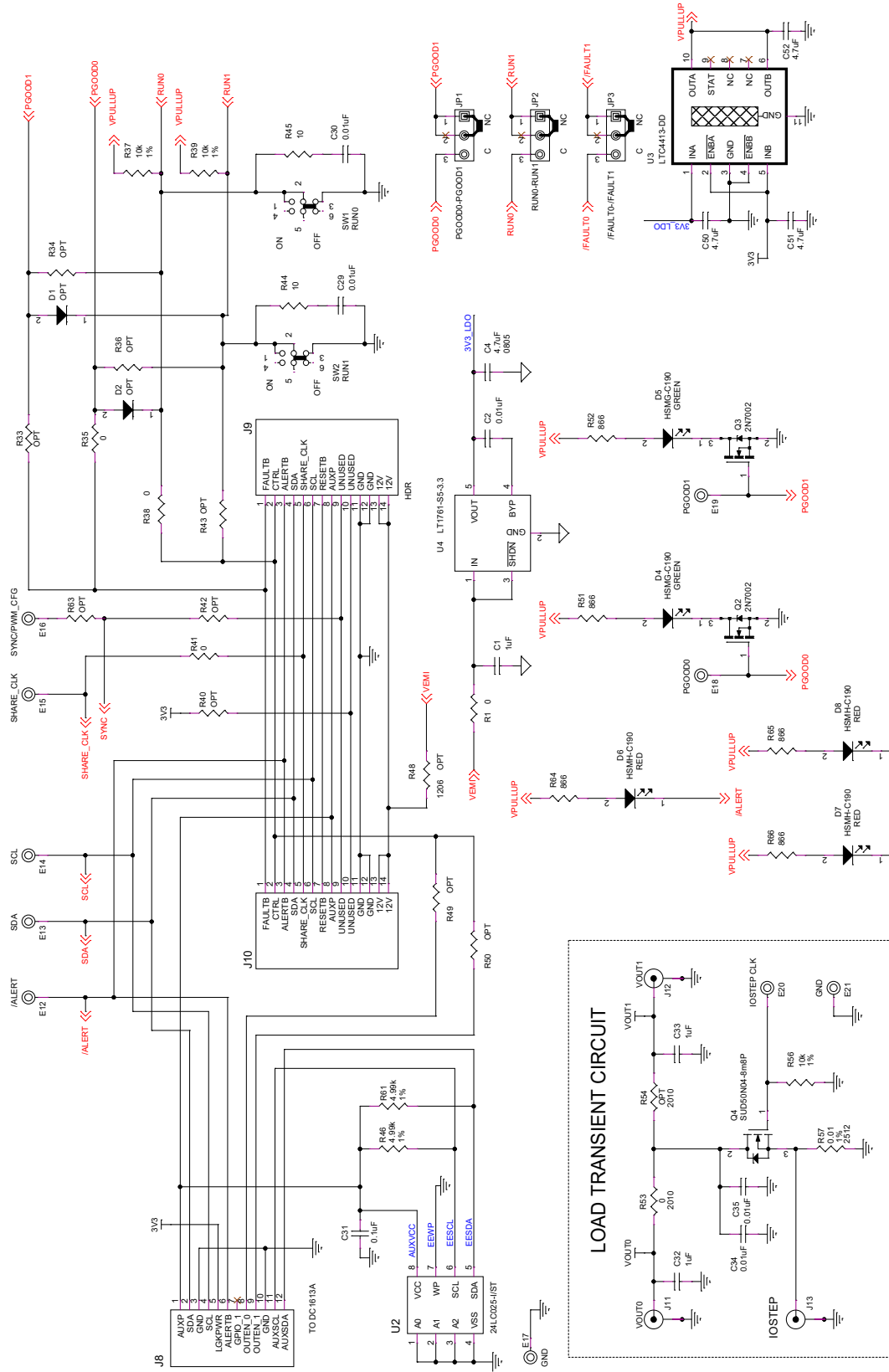

NOTE: UNLESS OTHERWISE SPECIFIED  
 1. ALL RESISTORS AND CAPACITORS ARE 0603.  
 2. FOR SINGLE OUTPUT CONFIGURATION.



## ESD Caution



**ESD (electrostatic discharge) sensitive device.** Charged devices and circuit boards can discharge without detection. Although this product features patented or proprietary protection circuitry, damage may occur on devices subjected to high energy ESD. Therefore, proper ESD precautions should be taken to avoid performance degradation or loss of functionality.

## Legal Terms and Conditions

By using the evaluation board discussed herein (together with any tools, components documentation or support materials, the "Evaluation Board"), you are agreeing to be bound by the terms and conditions set forth below ("Agreement") unless you have purchased the Evaluation Board, in which case the Analog Devices Standard Terms and Conditions of Sale shall govern. Do not use the Evaluation Board until you have read and agreed to the Agreement. Your use of the Evaluation Board shall signify your acceptance of the Agreement. This Agreement is made by and between you ("Customer") and Analog Devices, Inc. ("ADI"), with its principal place of business at One Technology Way, Norwood, MA 02062, USA. Subject to the terms and conditions of the Agreement, ADI hereby grants to Customer a free, limited, personal, temporary, non-exclusive, non-sublicensable, non-transferable license to use the Evaluation Board FOR EVALUATION PURPOSES ONLY. Customer understands and agrees that the Evaluation Board is provided for the sole and exclusive purpose referenced above, and agrees not to use the Evaluation Board for any other purpose. Furthermore, the license granted is expressly made subject to the following additional limitations: Customer shall not (i) rent, lease, display, sell, transfer, assign, sublicense, or distribute the Evaluation Board; and (ii) permit any Third Party to access the Evaluation Board. As used herein, the term "Third Party" includes any entity other than ADI, Customer, their employees, affiliates and in-house consultants. The Evaluation Board is NOT sold to Customer; all rights not expressly granted herein, including ownership of the Evaluation Board, are reserved by ADI. CONFIDENTIALITY. This Agreement and the Evaluation Board shall all be considered the confidential and proprietary information of ADI. Customer may not disclose or transfer any portion of the Evaluation Board to any other party for any reason. Upon discontinuation of use of the Evaluation Board or termination of this Agreement, Customer agrees to promptly return the Evaluation Board to ADI. ADDITIONAL RESTRICTIONS. Customer may not disassemble, decompile or reverse engineer chips on the Evaluation Board. Customer shall inform ADI of any occurred damages or any modifications or alterations it makes to the Evaluation Board, including but not limited to soldering or any other activity that affects the material content of the Evaluation Board. Modifications to the Evaluation Board must comply with applicable law, including but not limited to the RoHS Directive. TERMINATION. ADI may terminate this Agreement at any time upon giving written notice to Customer. Customer agrees to return to ADI the Evaluation Board at that time. LIMITATION OF LIABILITY. THE EVALUATION BOARD PROVIDED HEREUNDER IS PROVIDED "AS IS" AND ADI MAKES NO WARRANTIES OR REPRESENTATIONS OF ANY KIND WITH RESPECT TO IT. ADI SPECIFICALLY DISCLAIMS ANY REPRESENTATIONS, ENDORSEMENTS, GUARANTEES, OR WARRANTIES, EXPRESS OR IMPLIED, RELATED TO THE EVALUATION BOARD INCLUDING, BUT NOT LIMITED TO, THE IMPLIED WARRANTY OF MERCHANTABILITY, TITLE, FITNESS FOR A PARTICULAR PURPOSE OR NON-INFRINGEMENT OF INTELLECTUAL PROPERTY RIGHTS. IN NO EVENT WILL ADI AND ITS LICENSORS BE LIABLE FOR ANY INCIDENTAL, SPECIAL, INDIRECT, OR CONSEQUENTIAL DAMAGES RESULTING FROM CUSTOMER'S POSSESSION OR USE OF THE EVALUATION BOARD, INCLUDING BUT NOT LIMITED TO LOST PROFITS, DELAY COSTS, LABOR COSTS OR LOSS OF GOODWILL. ADI'S TOTAL LIABILITY FROM ANY AND ALL CAUSES SHALL BE LIMITED TO THE AMOUNT OF ONE HUNDRED US DOLLARS (\$100.00). EXPORT. Customer agrees that it will not directly or indirectly export the Evaluation Board to another country, and that it will comply with all applicable United States federal laws and regulations relating to exports. GOVERNING LAW. This Agreement shall be governed by and construed in accordance with the substantive laws of the Commonwealth of Massachusetts (excluding conflict of law rules). Any legal action regarding this Agreement will be heard in the state or federal courts having jurisdiction in Suffolk County, Massachusetts, and Customer hereby submits to the personal jurisdiction and venue of such courts. The United Nations Convention on Contracts for the International Sale of Goods shall not apply to this Agreement and is expressly disclaimed.

## Looking for pricing, stock, or lifecycle information?

Click below to explore more details on WIN SOURCE:

-  [View DC2836A on WIN SOURCE](#)
-  [Analog Devices Inc. Information](#)

## Optimize Your Supply Chain with WIN SOURCE Solutions

-  Global Sourcing Solution
-  Obsolete Management
-  Cost Control Management
-  Shortage Management
-  Alternative Solution
-  Excess Inventory Management