



**THE DATASHEET OF
LP320F33CET**



ATSSMLP Series

Low Profile Quartz Crystal



Part Dimensions:
11.1 x 4.83 x 3.2mm • 587.84mg

Features

- Low Profile HC-49/US-SM Metal Package
- Fundamental and 3rd Overtone Crystal Design
- Frequency Range 3.2 – 64MHz
- Frequency Tolerance, ± 30 ppm Standard
- Frequency Stability, ± 30 ppm Standard
- Operating Temperature Range -20°C to +70°C or -40°C to +85°C
- Tape and Reel Packaging, EIA-481

Applications

- Wireless Communications
- Broadband Access
- FPGA/Microcontrollers
- Computer Peripherals
- Microprocessors
- Test and Measurement
- Consumer Electronics
- Portable Equipment

Description

CTS ATSSMLP incorporates a high Q quartz resonator in a proven resistance-weld metal package. ATSSMLP offers tight stability options that are ideal for supporting a wide range of commercial and industrial applications.

Ordering Information

Model	Frequency Code [MHz]	Mode of Oscillation	Tolerance @ +25°C	Temperature Stability	Temperature Range	Load Capacitance	Packaging
LP	XXX	F	3	3	I	D	T
	Code Frequency		Code Tolerance		Code Temp. Range		Code Packing
	Product Frequency Code ¹		1 ± 10 ppm X ± 15 ppm 2 ± 20 ppm Y ± 25 ppm 3 ± 30 ppm		C -20°C to +70°C I -40°C to +85°C		T Tape & Reel
		Code Mode		Code Stability		Code Capacitance	Code Capacitance
		F Fundamental T 3rd Overtone		1 ± 10 ppm ² X ± 15 ppm 2 ± 20 ppm Y ± 25 ppm 3 ± 30 ppm 5 ± 50 ppm		K 8pF E 20pF J 9pF F 24pF A 10pF G 30pF L 12pF H 32pF B 13pF Y 40pF C 16pF S Series D 18pF	

Notes:

1] Refer to document 016-1454-0, Frequency Code Tables. 3-digits for frequencies <100MHz.

2] Check factory availability when combined with -40°C to +85°C temperature range.

**Not all performance combinations and frequencies may be available.
Contact your local CTS Representative or CTS Customer Service for availability.**

This product is specified for use only in standard commercial applications. Supplier disclaims all express and implied warranties and liability in connection with any use of this product in any non-commercial applications or in any application that may expose the product to conditions that are outside of the tolerances provided in its specification.



Electrical Specifications

Operating Conditions

PARAMETER	SYMBOL	CONDITIONS	MIN	TYP	MAX	UNIT
Operating Temperature	T_A	-	-20 -40	+25	+70 +85	°C
Storage Temperature	T_{STG}	-	-40	-	+125	°C

Frequency Stability

PARAMETER	SYMBOL	CONDITIONS	MIN	TYP	MAX	UNIT
Frequency Range						
Fundamental	f_0	-		3.2 - 40		MHz
3rd Overtone				24 - 64		
Frequency Tolerance	$\Delta f/f_0$	@ +25°C		10, 15, 20, 25 or 30		±ppm
Frequency Stability	$\Delta f/f_{25}$	Referenced to +25°C reading		10, 15, 20, 25, 30 or 50		±ppm
Aging	$\Delta f/f_0$	Typical per year @ +25°C	-5	±3	5	ppm

Crystal Parameters

PARAMETER	SYMBOL	CONDITIONS	MIN	TYP	MAX	UNIT
Operating Mode	-	-	Fundamental or 3rd Overtone			-
Crystal Cut	-	-	AT-Cut			-
Load Capacitance	C_L	-	See Ordering Information			pF
Shunt Capacitance	C_0	-	-	-	7.0	pF
Series Resistance						
Fundamental	R1	3.2MHz - <4.0MHz	-	-	150	Ω
		4.0MHz - <5.0MHz	-	-	120	
		5.0MHz - <8.0MHz	-	-	80	
		8.0MHz - <12.0MHz	-	-	60	
		12.0MHz - <20.0MHz	-	-	40	
		20.0MHz - 40.0MHz	-	-	30	
3rd Overtone	R1	24.0MHz - <48.0MHz	-	-	80	
		48.0MHz - 64.0MHz	-	-	60	
Drive Level	DL	-	-	100	1000	μW
Insulation Resistance	R_i	+100Vdc ±15Vdc	500	-	-	MΩ

$\Delta f/f_0$ - Frequency deviation referenced to nominal frequency.

$\Delta f/f_{25}$ - Frequency deviation over operating temperature range, referenced to +25°C frequency.

Mechanical Specifications

Package Drawing

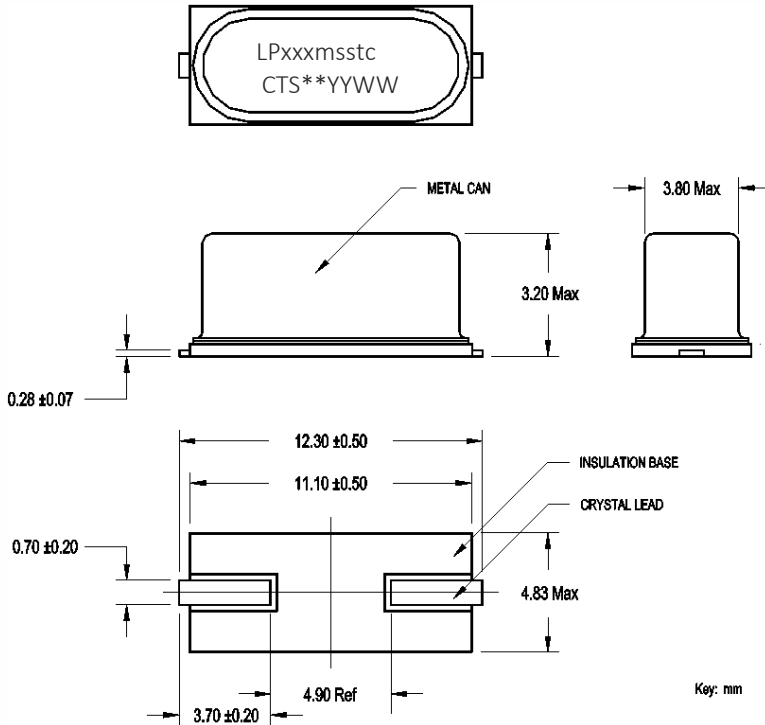

Marking Information *

- LPxxxmsstc – Truncated CTS Part Number. [Packaging code is not required in the marking.]
 - LP – ATSSMLP platform.
 - xxx – 3-digit Frequency Code. [Reference document 016-1454-01]
 - m – Operating Mode. F = Fundamental, T = 3rd Overtone.
 - sstc – Tolerance, Stability, Temperature Range and Load Capacitance codes, Reference Ordering Information.
- ** – Manufacturing Site Code.
- YYWW – Date Code; YY = year, WW = week.

*See Alternate Marking Information for “11” tolerance, stability, temperature product code only. [Tol = ±10ppm, Stab = ±10ppm, Temp = -40°C/+85°C]

Schematic

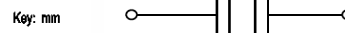

Recommended Pad Layout

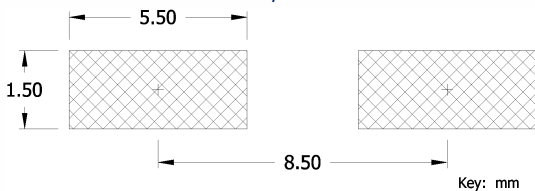

Notes

- JEDEC termination code (e1). Barrier-plating is nickel [Ni] with tin-silver-copper [SnAgCu] lead finish.
- Reflow conditions per JEDEC J-STD-020; +260°C maximum, 20 seconds.
- MSL = 1.

Alternate Marking Information

- xxxmsst**D – Truncated CTS Part Number. [Load and Packaging code is not required in the marking.]
 - xxx – 3-digit Frequency Code. [Reference document 016-1454-01]
 - m – Operating Mode. F = Fundamental, T = 3rd Overtone
 - sst – Tolerance, Stability, Temperature Range and Load Capacitance codes, Reference Ordering Information.
 - ** – Manufacturing Site Code.
 - D – Date Code. See Table I for codes.

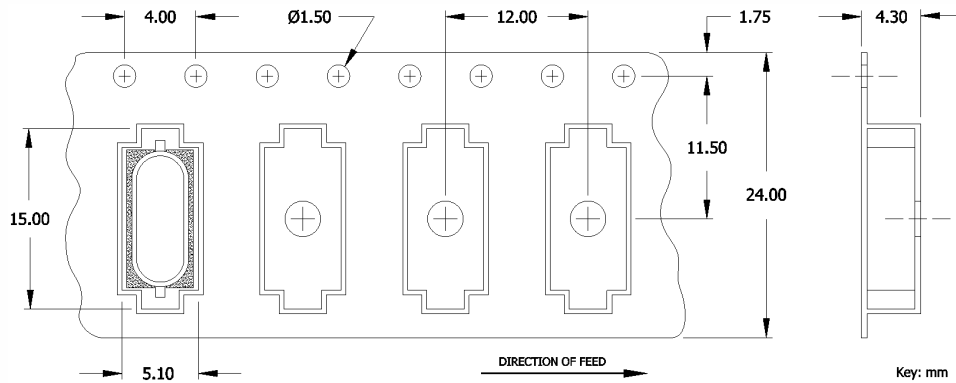

Table I – Date Code, Beginning year 2021

YEAR					MONTH											
					JAN	FEB	MAR	APR	MAY	JUN	JUL	AUG	SEP	OCT	NOV	DEC
2021	2025	2029	2033	2037	A	B	C	D	E	F	G	H	J	K	L	M
2022	2026	2030	2034	2038	N	P	Q	R	S	T	U	V	W	X	Y	Z
2023	2027	2031	2035	2039	a	b	c	d	e	f	g	h	j	k	l	m
2024	2028	2032	2036	2040	n	p	q	r	s	t	u	v	w	x	y	z

Packaging – Tape and Reel

Tape Drawing



Reel Drawing

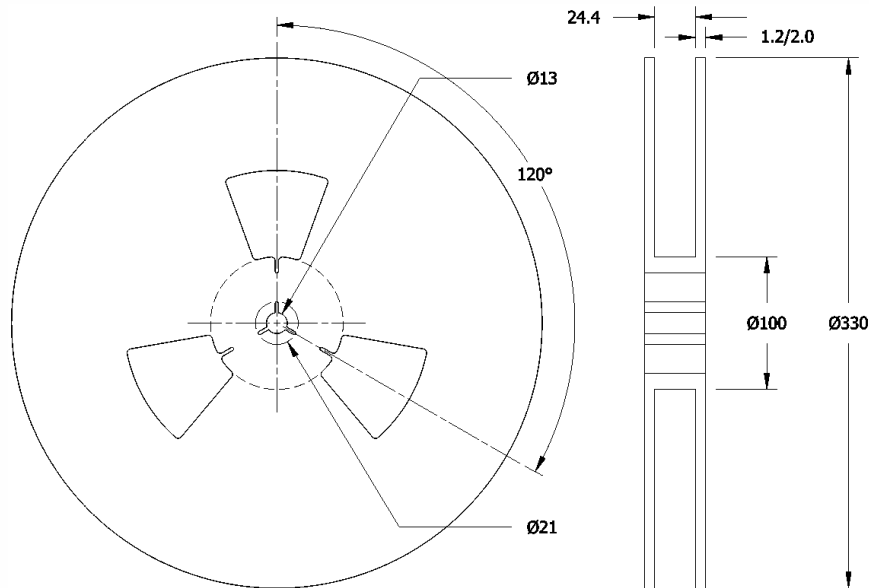

Notes

1. Device quantity is 1k pieces maximum per 330mm reel.
2. Complete CTS part number, frequency value, date code and manufacturing site code information must appear on reel and carton labels.

Looking for pricing, stock, or lifecycle information?

Click below to explore more details on WIN SOURCE:

-  [View LP320F33CET on WIN SOURCE](#)
-  [CTS-Frequency Controls Information](#)

Optimize Your Supply Chain with WIN SOURCE Solutions

-  Global Sourcing Solution
-  Obsolete Management
-  Cost Control Management
-  Shortage Management
-  Alternative Solution
-  Excess Inventory Management