



THE DATASHEET OF LM4565FV-GE2



Operational Amplifiers

Low Noise Operational Amplifier

LM4565xxx

General Description

The LM4565xxx are low noise operational amplifiers with high voltage gain and wide bandwidth. They have good performance of input referred noise voltage ($5\text{ nV}/\sqrt{\text{Hz}}$) and total harmonic distortion (0.0002%). These are suitable for audio applications and active filter.

Features

- High Voltage Gain
- High Slew Rate
- Low Input Referred Noise Voltage
- Low Total Harmonic Distortion
- Wide Gain Bandwidth

Application

- Audio Application
- Consumer Equipment
- Active Filter

Key Specifications

- Operating Supply Voltage: $\pm 2\text{V}$ to $\pm 18\text{V}$
- Temperature Range: -40°C to $+85^\circ\text{C}$
- Voltage Gain ($R_L=2\text{k}\Omega$): 100dB(Typ)
- Slew Rate: $5.0\text{V}/\mu\text{s}$ (Typ)
- Gain Bandwidth: 10MHz (Typ)
- Input Referred Noise Voltage: $5\text{ nV}/\sqrt{\text{Hz}}$ (Typ)

Package

	W(Typ) xD(Typ) xH(Max)
SOP-8	5.00mm x 6.20mm x 1.71mm
SOP-J8	4.90mm x 6.00mm x 1.65mm
SSOP-B8	3.00mm x 6.40mm x 1.35mm
TSSOP-B8	3.00mm x 6.40mm x 1.20mm
MSOP8	2.90mm x 4.00mm x 0.90mm
TSSOP-B8J	3.00mm x 4.90mm x 1.10mm

Pin Configuration

LM4565F	: SOP8
LM4565FJ	: SOP-J8
LM4565FV	: SSOP-B8
LM4565FVT	: TSSOP-B8
LM4565FVM	: MSOP8
LM4565FVJ	: TSSOP-B8J

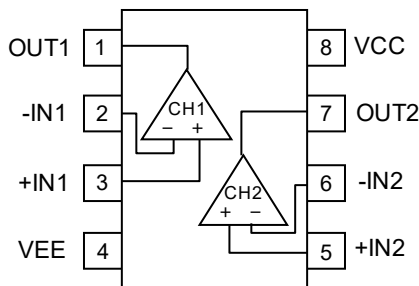

Pin No.	Pin Name
1	OUT1
2	-IN1
3	+IN1
4	VEE
5	+IN2
6	-IN2
7	OUT2
8	VCC

Figure1. Pin Configuration

○Product structure : Silicon monolithic integrated circuit ○This product has no designed protection against radioactive rays.

Ordering Information

L M 4 5 6 5 x x x	-	x x
Part Number LM4565xxx	Package F : SOP8 FJ : SOP-J8 FV : SSOP-B8 FVT : TSSOP-B8 FVM : MSOP8 FVJ : TSSOP-B8J	Packaging and forming specification E2: Embossed tape and reel (SOP8/SOP-J8/SSOP-B8/TSSOP-B8/TSSOP-B8J) TR: Embossed tape and reel (MSOP8)

Line-up

T_{opr}	Package		Orderable Part Number
-40°C to +85°C	SOP8	Reel of 2500	LM4565F-E2
	SOP-J8	Reel of 2500	LM4565FJ-E2
	SSOP-B8	Reel of 2500	LM4565FV-E2
	TSSOP-B8	Reel of 3000	LM4565FVT-E2
	MSOP8	Reel of 3000	LM4565FVM-TR
	TSSOP-B8J	Reel of 2500	LM4565FVJ-E2

Absolute Maximum Ratings ($T_A=25^\circ\text{C}$)

Parameter	Symbol	Rating	Unit	
Supply Voltage	VCC - VEE	+36	V	
Power Dissipation	P _D	SOP8	0.68 ^(Note 1,5)	W
		SOP-J8	0.67 ^(Note 2,5)	
		SSOP-B8	0.62 ^(Note 3,5)	
		TSSOP-B8	0.62 ^(Note 3,5)	
		MSOP8	0.58 ^(Note 4,5)	
		TSSOP-B8J	0.58 ^(Note 4,5)	
Differential Input Voltage ^(Note 6)	V _{ID}	+36	V	
Input Common-mode Voltage Range	V _{ICM}	(VEE - 0.3) to (VEE + 36)	V	
Operating Voltage	V _{opr}	±2 to ±18	V	
Operating Temperature	T _{opr}	- 40 to +85	°C	
Storage Temperature	T _{stg}	- 55 to +150	°C	
Maximum Junction Temperature	T _{Jmax}	+150	°C	

(Note 1) When used at temperature above $T_A=25^\circ\text{C}$, reduce by 5.5mW/°C.

(Note 2) When used at temperature above $T_A=25^\circ\text{C}$, reduce by 5.4mW/°C.

(Note 3) When used at temperature above $T_A=25^\circ\text{C}$, reduce by 5.0mW/°C.

(Note 4) When used at temperature above $T_A=25^\circ\text{C}$, reduce by 4.7mW/°C.

(Note 5) Mounted on a FR4 glass epoxy PCB(70mm×70mm×1.6mm).

(Note 6) The differential input voltage is the voltage difference between inverting input and non-inverting input.

Input terminal voltage is set to more than VEE.

Caution: Operating the IC over the absolute maximum ratings may damage the IC. The damage can either be a short circuit between pins or an open circuit between pins and the internal circuitry. Therefore, it is important to consider circuit protection measures, such as adding a fuse, in case the IC is operated over the absolute maximum ratings.

Electrical Characteristics:

OLM4565xxx (Unless otherwise specified VCC = +15V, VEE = -15V)

Parameter	Symbol	Temperature Range	Limit			Unit	Conditions
			Min	Typ	Max		
Input Offset Voltage (Note 7)	V _{IO}	25°C	-	0.5	1.5	mV	R _S ≤10kΩ
Input Offset Current (Note 7)	I _{IO}	25°C	-	2	50	nA	-
Input Bias Current (Note 7)	I _B	25°C	-	70	250	nA	-
Supply Current (Note 8)	I _{CC}	25°C	-	4.5	7	mA	R _L =∞, All Op-Amps +IN=0V
		Full range	-	-	8.5		
Large Signal Voltage Gain	A _v	25°C	86	100	-	dB	R _L ≥2kΩ, OUT=±10V
Maximum Output Voltage	V _{OM}	25°C	±12	±14	-	V	R _L ≥2kΩ
		25°C	±11	±12.5	-	V	I _O =25mA
Input Common-mode Voltage Range	V _{ICM}	25°C	±12	±14	-	V	-
Output Source Current (Note 9)	I _{SOURCE}	25°C	-	130	-	mA	+IN=1V, -IN=0V OUT=-15V 1CH is short circuit
Output Sink Current (Note 9)	I _{SINK}	25°C	-	160	-	mA	+IN=0V, -IN=1V OUT=+15V 1CH is short circuit
Common-mode Rejection Ratio	CMRR	25°C	80	100	-	dB	R _L ≤10kΩ
Power Supply Rejection Ratio	PSRR	25°C	82	100	-	dB	R _L ≤10kΩ
Slew Rate	SR	25°C	-	5	-	V/μs	R _L =2kΩ, C _L =100pF
Unity Gain Frequency	f _r	25°C	-	4	-	MHz	R _L =2kΩ
Gain Bandwidth	GBW	25°C	-	10	-	MHz	R _L =2kΩ, f=100kHz
Phase Margin	θ	25°C	-	40	-	deg	R _L =2kΩ
Input Referred Noise Voltage	V _N	25°C	-	0.6	-	μVrms	A _v =40dB R _S =100Ω DIN-AUDIO
			-	5	-	nV/√Hz	A _v =40dB, V _{ICM} =0V R _S =100Ω, f=1kHz
Total Harmonic Distortion + Noise	THD+N	25°C	-	0.0002	-	%	A _v =20dB, f=1kHz OUT=5Vrms
Channel Separation	CS	25°C	-	110	-	dB	A _v =40dB, f=1kHz OUT=1Vrms

(Note 7) Absolute value.

(Note 8) Full range: T_A=-40°C to +85°C

(Note 9) Please consider the power dissipation when selecting the output current.

When the output terminal is continuously shorted the output current reduces the internal temperature by flushing.

Description of Electrical Characteristics

Described here are the terms of electric characteristics used in this datasheet. Items and symbols used are also shown. Note that item name, symbol and their meaning may differ from those on other manufacturer's document or general documents.

1. Absolute maximum ratings

Absolute maximum rating items indicate the condition which must not be exceeded. Application of voltage in excess of absolute maximum rating or use out of absolute maximum rated temperature environment may cause deterioration of characteristics.

- (1) Supply Voltage (VCC/VEE)
Indicates the maximum voltage that can be applied between the positive power supply terminal and negative power supply terminal without deterioration or destruction of characteristics of internal circuit.
- (2) Differential Input Voltage (V_{ID})
Indicates the maximum voltage that can be applied between non-inverting and inverting terminals without damaging the IC.
- (3) Input Common-mode Voltage Range (V_{ICM})
Indicates the maximum voltage that can be applied to the non-inverting and inverting terminals without deterioration or destruction of electrical characteristics. Input common-mode voltage range of the maximum ratings does not assure normal operation of IC. For normal operation, use the IC within the input common-mode voltage range characteristics.
- (4) Power dissipation (P_D)
Indicates the power that can be consumed by the IC when mounted on a specific board at the ambient temperature 25°C (normal temperature). As for package product, P_D is determined by the temperature that can be permitted by the IC in the package (maximum junction temperature) and the thermal resistance of the package.

2. Electrical characteristics item

- (1) Input Offset Voltage (V_{IO})
Indicates the voltage difference between non-inverting terminal and inverting terminals. It can be translated into the input voltage difference required for setting the output voltage at 0 V.
- (2) Input Offset Current (I_{IO})
Indicates the difference of input bias current between the non-inverting and inverting terminals.
- (3) Input Bias Current (I_B)
Indicates the current that flows into or out of the input terminal. It is defined by the average of input bias currents at the non-inverting and inverting terminals.
- (4) Supply Current (I_{CC})
Indicates the current that flows within the IC under specified no-load conditions.
- (5) Large Signal Voltage Gain (A_v)
Indicates the amplifying rate (gain) of output voltage against the voltage difference between non-inverting terminal and inverting terminal. It is normally the amplifying rate (gain) with reference to DC voltage.
 $A_v = (\text{Output voltage}) / (\text{Differential Input voltage})$
- (6) Maximum Output Voltage (V_{OM})
Indicates the voltage range that the IC can output under specified load condition. It is typically divided into high-level output voltage and low-level output voltage. High-level output voltage indicates the upper limit of output voltage. Low-level output voltage indicates the lower limit.
- (7) Input Common-mode Voltage Range (V_{ICM})
Indicates the input voltage range where IC operates normally.
- (8) Output Source Current/ Output Sink Current (I_{SOURCE} / I_{SINK})
The maximum current that can be output from the IC under specific output conditions. The output source current indicates the current flowing out from the IC, and the output sink current indicates the current flowing into the IC.
- (9) Common-mode Rejection Ratio (CMRR)
Indicates the ratio of fluctuation of input offset voltage when the input common-mode voltage is changed. It is normally the fluctuation of DC.
 $CMRR = (\text{Change of Input common-mode voltage}) / (\text{Input offset fluctuation})$
- (10) Power Supply Rejection Ratio (PSRR)
Indicates the ratio of fluctuation of input offset voltage when supply voltage is changed.
It is normally the fluctuation of DC.
 $PSRR = (\text{Change of power supply voltage}) / (\text{Input offset fluctuation})$
- (11) Slew Rate (SR)
Indicates the ratio of the change in output voltage with time when a step input signal is applied.
- (12) Unity Gain Frequency (f_T)
Indicates a frequency where the voltage gain of operational amplifier is 1.
- (13) Gain Bandwidth (GBW)
Indicates to multiply by the frequency and the gain where the voltage gain decreases 6dB/octave.
- (14) Phase Margin (θ)
Indicates the margin of phase from 180 degree phase lag at unity gain frequency.
- (15) Input Referred Noise Voltage (V_N)
Indicates a noise voltage generated inside the operational amplifier reflected back to an ideal voltage source connected in series with the input terminal.

- (16) Total Harmonic Distortion + Noise (THD+N)
Indicates the fluctuation of input offset voltage or that of output voltage with reference to the change of output voltage of driven channel.
- (17) Channel Separation (CS)
Indicates the fluctuation in the output voltage of the driven channel with reference to the change of output voltage of the channel which is not driven.

Typical Performance Curves
OLM4565xxx

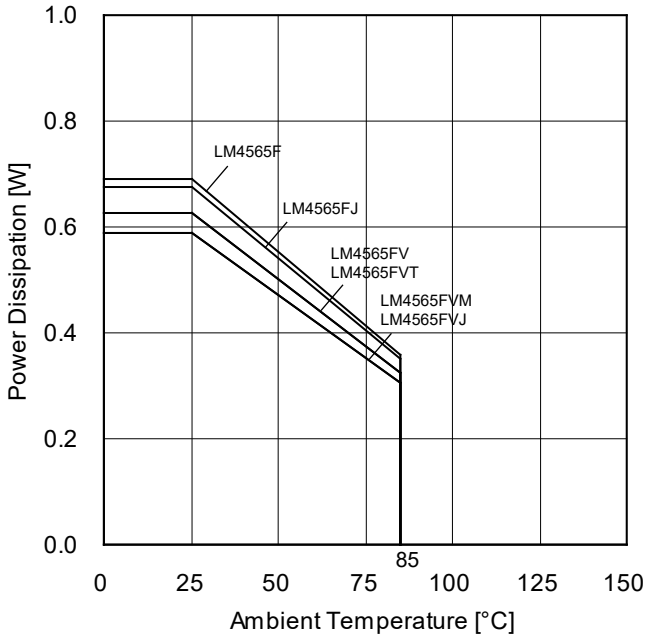

Figure 2.
Power Dissipation vs Ambient Temperature
(Derating Curve)

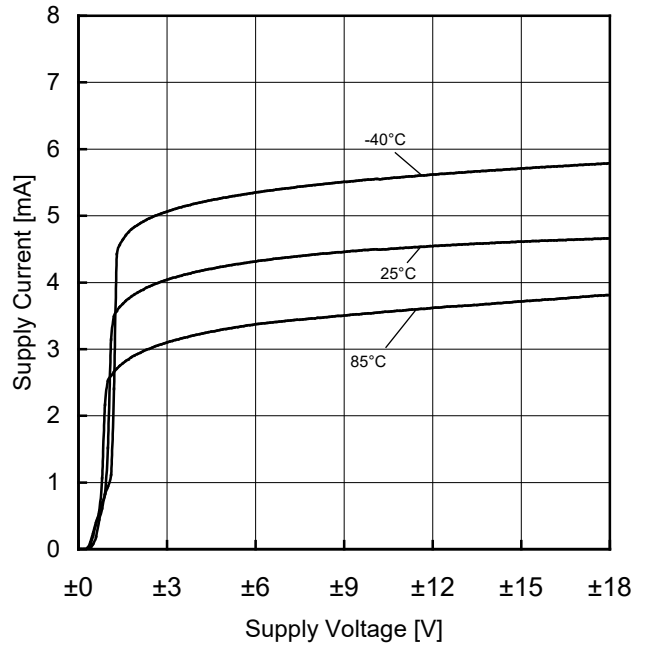

Figure 3.
Supply Current vs Supply Voltage

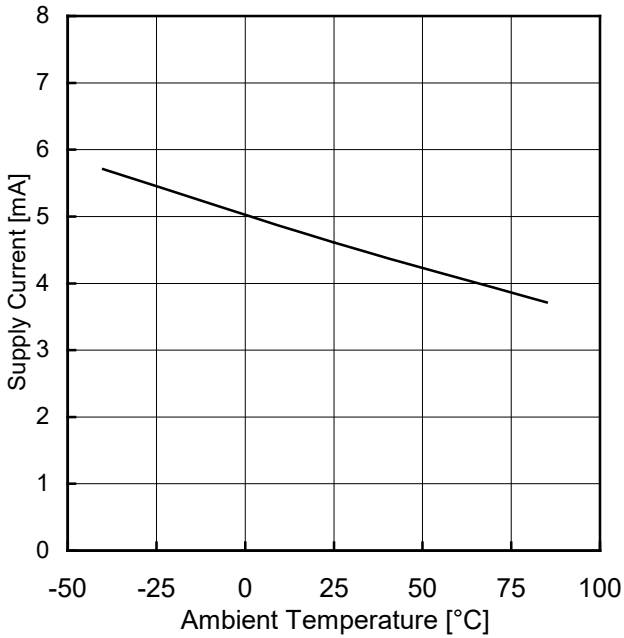

Figure 4.
Supply Current vs Ambient Temperature
(VCC/VEE=±15V)

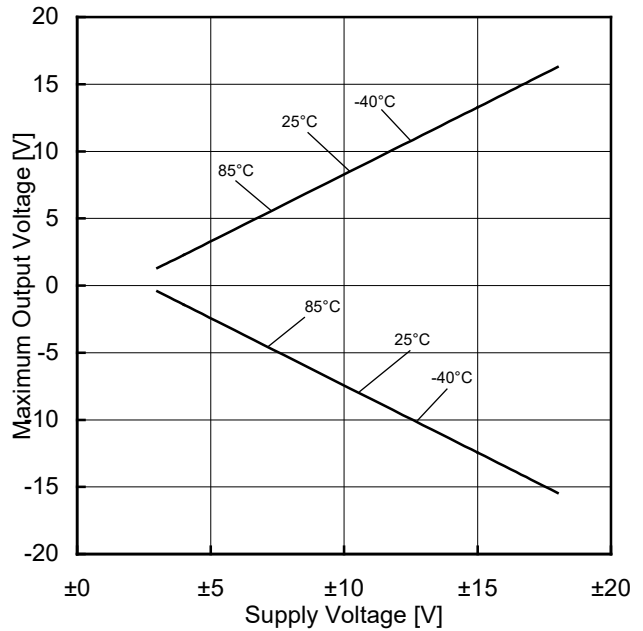

Figure 5.
Maximum Output Voltage vs Supply Voltage
($R_L=2k\Omega$, $T_A=25^\circ\text{C}$)

(*)The above characteristics are measurements of typical sample, they are not guaranteed.

Typical Performance Curves (Reference data) – continued
OLM4565xxx

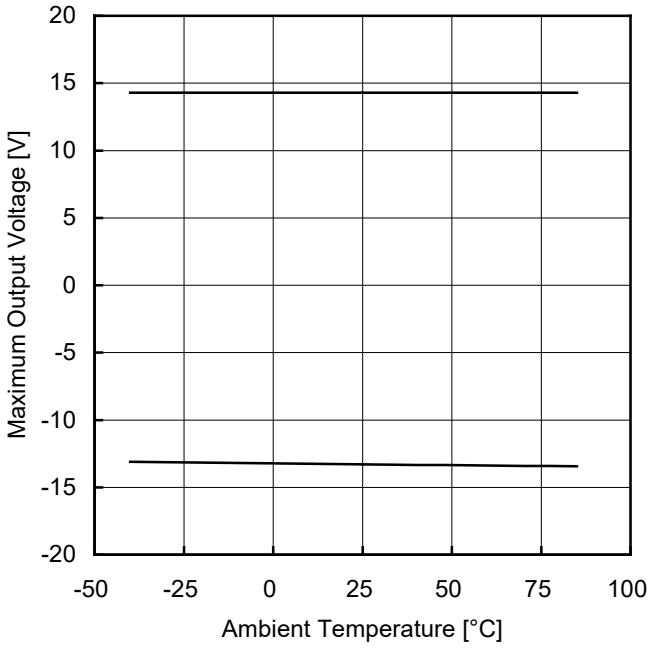

Figure 6.
Maximum Output Voltage vs Ambient Temperature
(VCC/VEE=±15V, RL=2KΩ)

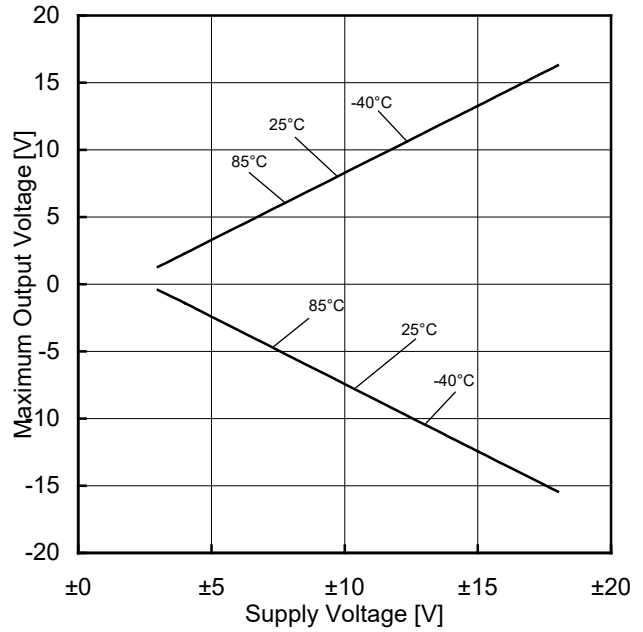

Figure 7.
Maximum Output Voltage vs Supply Voltage
(Io=25mA, TA=25°C)

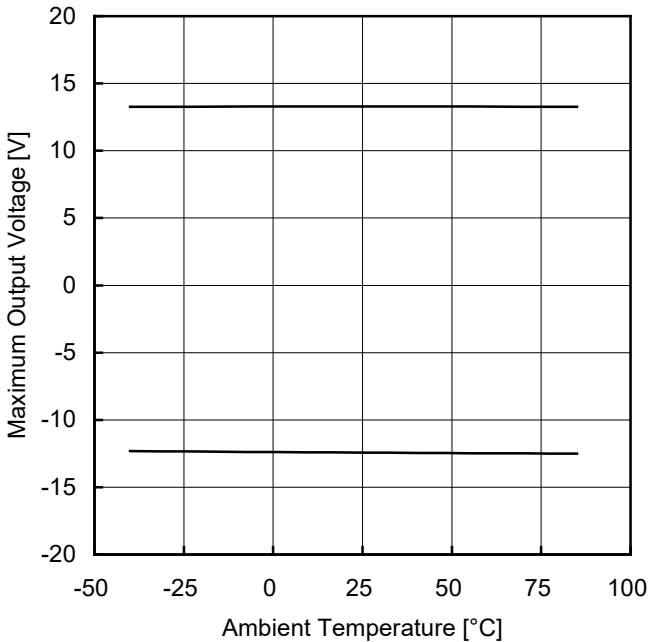

Figure 8.
Maximum Output Voltage vs Ambient Temperature
(VCC/VEE=±15V, Io=25mA)

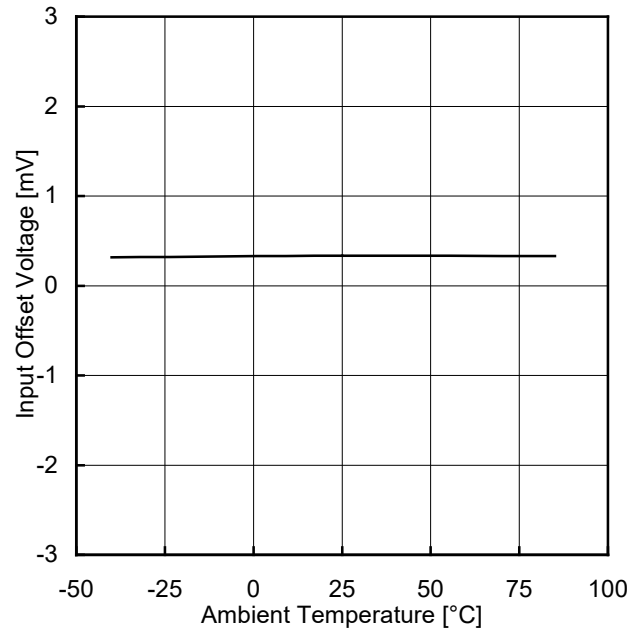

Figure 9.
Input Offset Voltage vs Ambient Temperature
(VCC/VEE=±15V)

(*)The above characteristics are measurements of typical sample, they are not guaranteed.

Typical Performance Curves (Reference data) – continued
OLM4565xxx

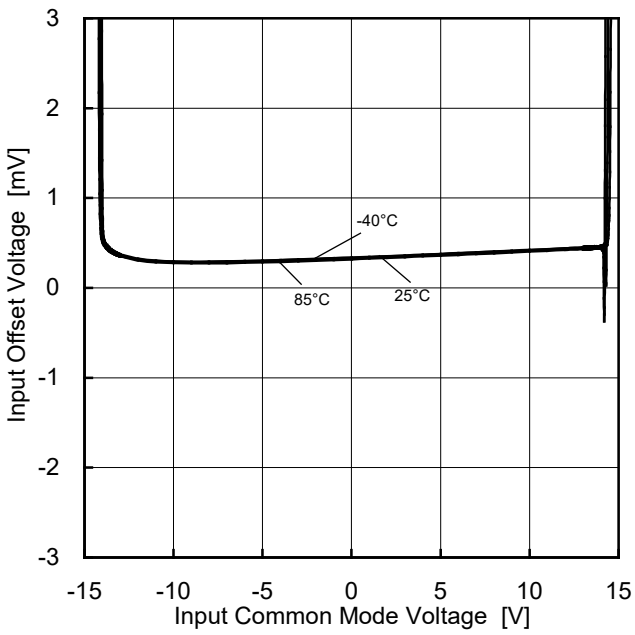

Figure 10.
Input Offset Voltage vs Input Common mode Voltage
(VCC/VEE=±15V)

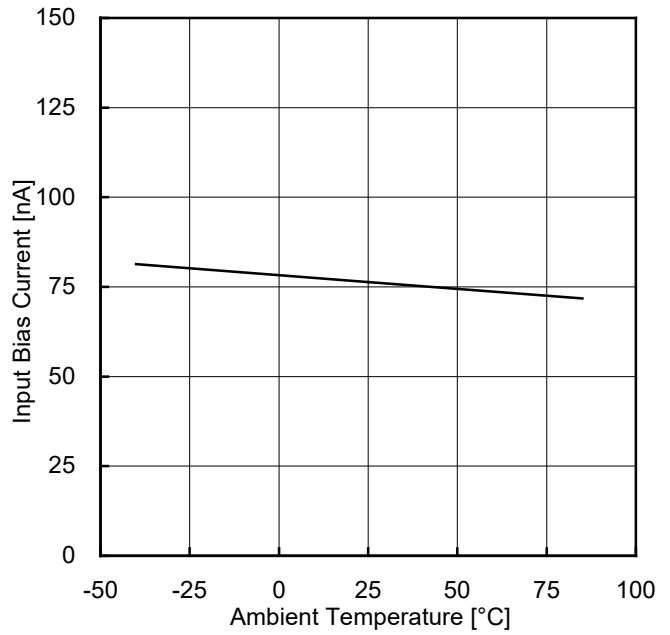

Figure 11.
Input Bias Current vs Ambient Temperature
(VCC/VEE=±15V)

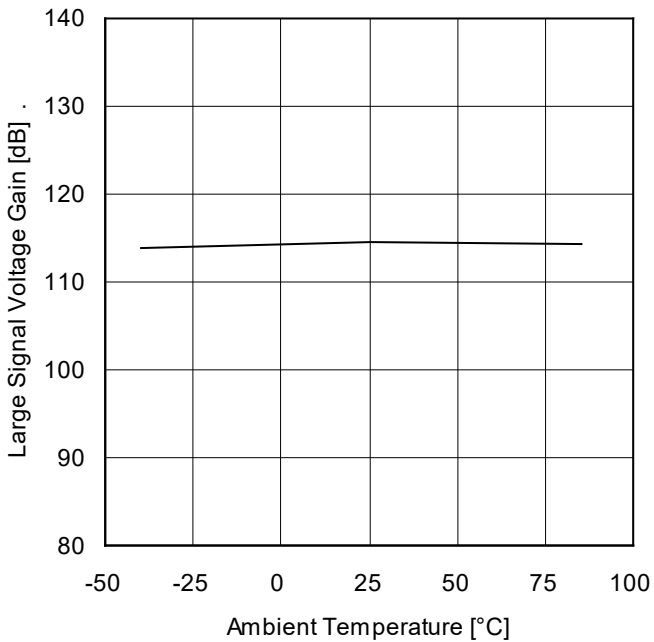

Figure 12.
Large Signal Voltage Gain vs Ambient Temperature
(VCC/VEE=±15V, RL=2kΩ)

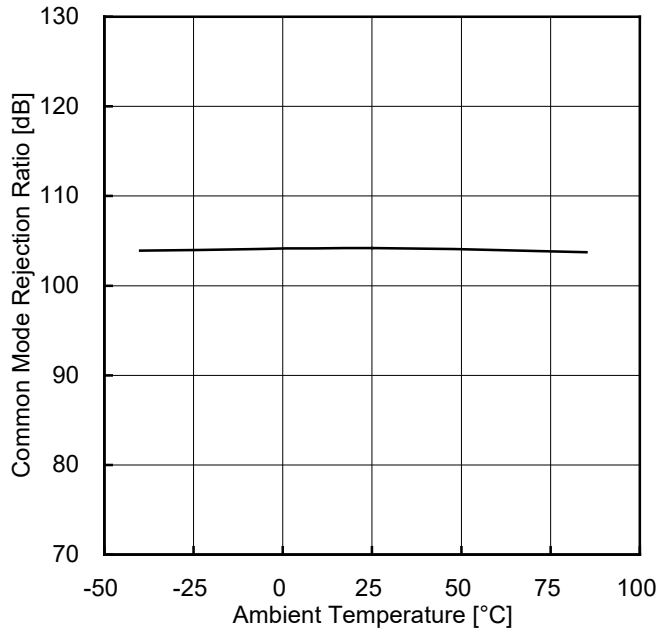

Figure 13.
Common Mode Rejection Ratio vs Ambient Temperature
(VCC/VEE=±15V)

(*)The above characteristics are measurements of typical sample, they are not guaranteed.

Typical Performance Curves (Reference data) - continued
OLM4565xxx

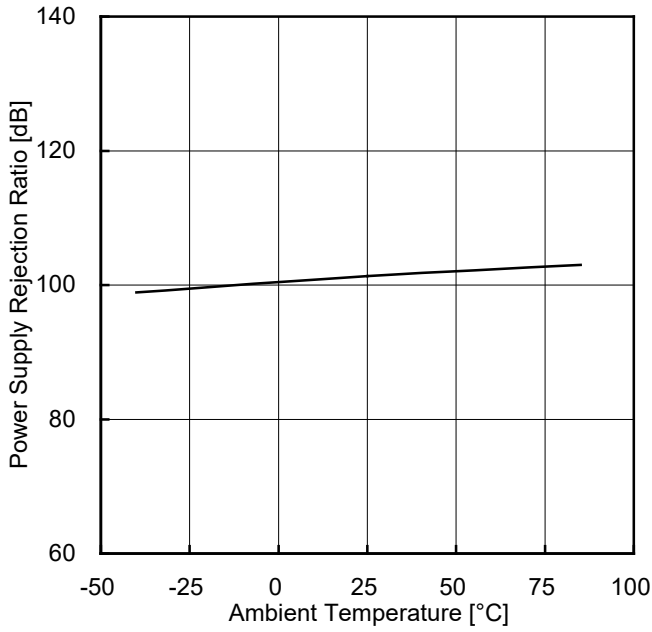

Figure 14.
Power Supply Rejection Ratio vs Ambient Temperature

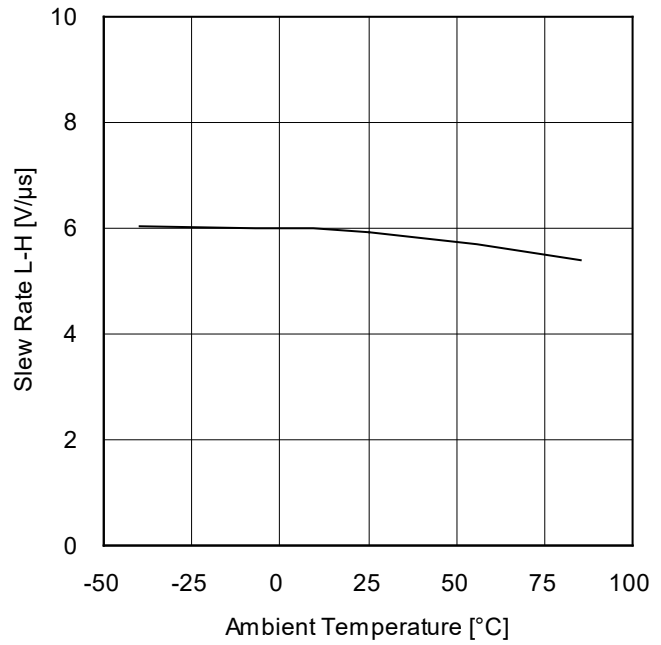

Figure 15.
Slew Rate L-H vs Ambient Temperature
(VCC/VEE=±15V, RL=2kΩ, CL=100pF)

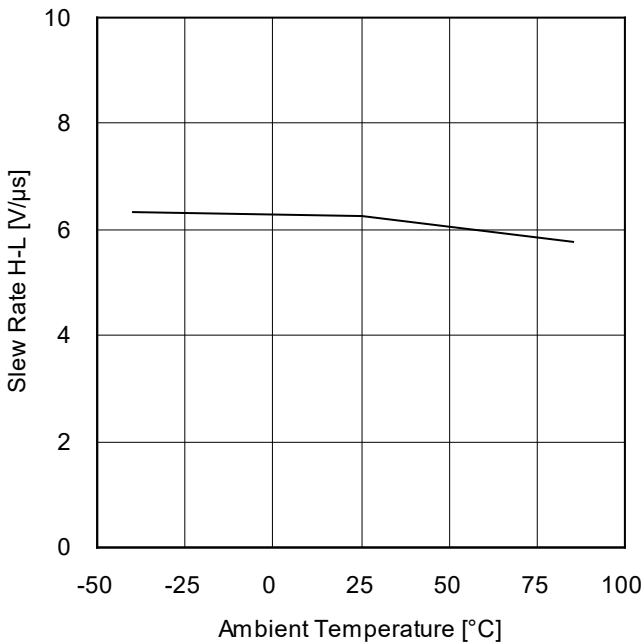

Figure 16.
Slew Rate H-L vs Ambient Temperature
(VCC/VEE=±15V, RL=2kΩ, CL=100pF)

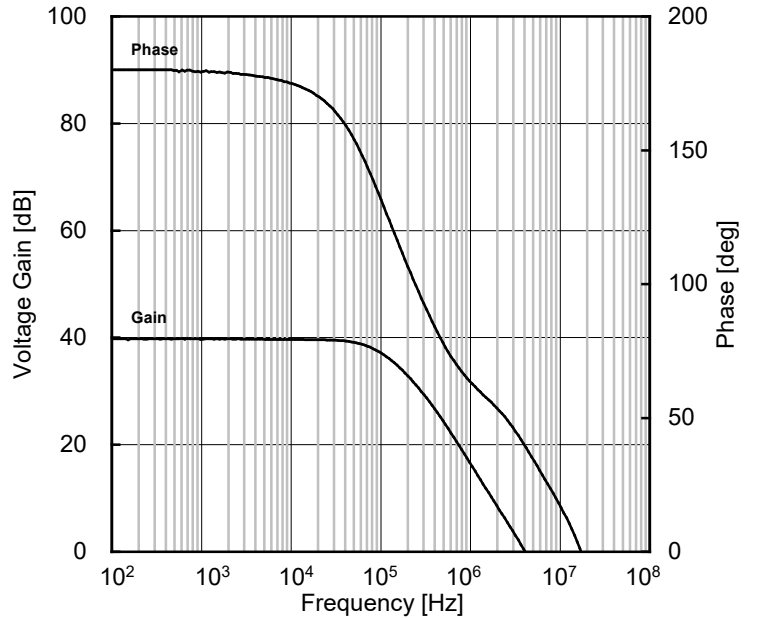

Figure 17.
Voltage Gain · Phase vs Frequency
(VCC/VEE=±15V, RL=2kΩ)

(*)The above characteristics are measurements of typical sample, they are not guaranteed.

Typical Performance Curves (Reference data) - continued
OLM4565xxx

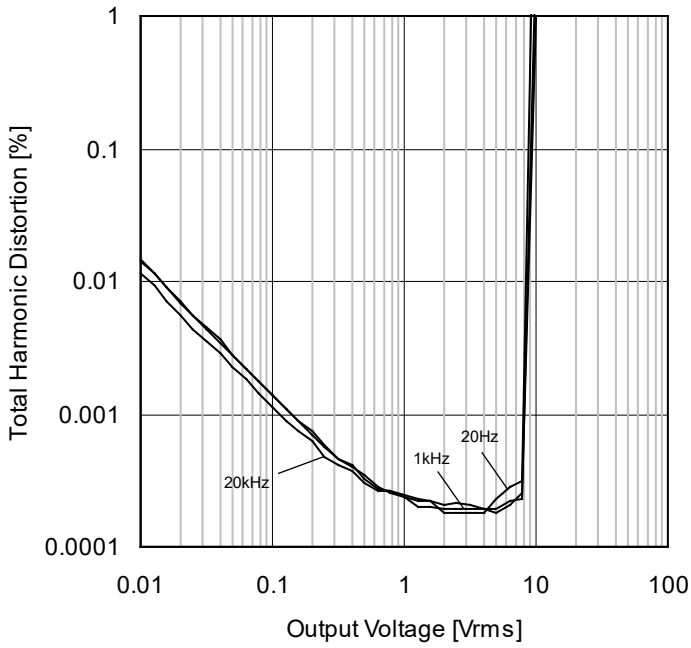

Figure 18.
Total Harmonic Distortion vs Output Voltage
(VCC/VEE=±15V, RL=2kΩ, f=1kHz)

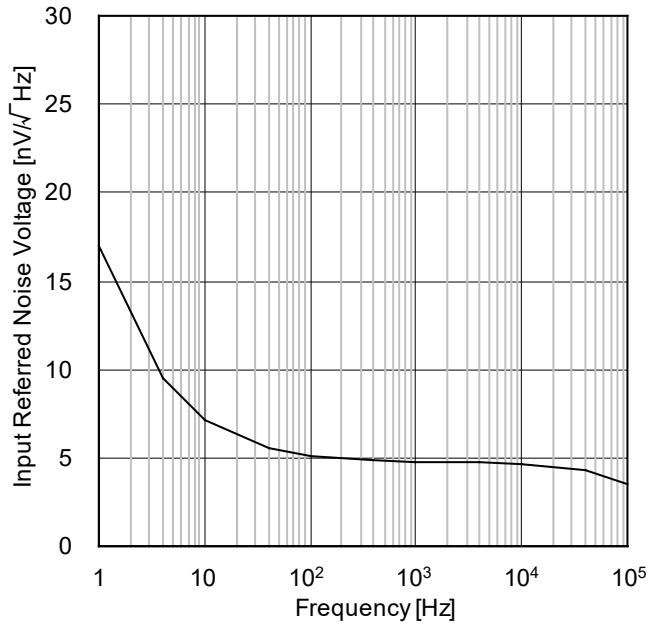

Figure 19.
Input Referred Noise Voltage vs Frequency
(VCC/VEE=±15V, TA=25°C, AV=40dB)

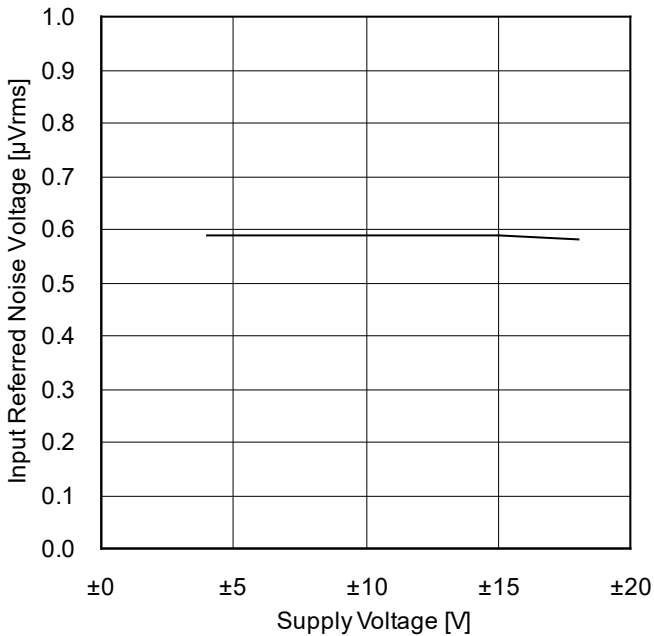

Figure 20.
Input Referred Noise Voltage vs Supply Voltage
(TA=25°C, DIN-AUDIO)

(*)The above characteristics are measurements of typical sample, they are not guaranteed.

Application Information
NULL method condition for Test Circuit 1

Parameter	V _{CC} , V _{EE} , E _K , V _{ICM} Unit:V								
	V _F	S1	S2	S3	V _{CC}	V _{EE}	E _K	V _{ICM}	Calculation
Input Offset Voltage	V _{F1}	ON	ON	OFF	15	-15	0	0	1
Large Signal Voltage Gain	V _{F2}	ON	ON	ON	15	-15	-10	0	2
	V _{F3}						10		
Common Mode Rejection Ratio (Input Common-mode Voltage Range)	V _{F4}	ON	ON	OFF	15	-15	0	-10	3
	V _{F5}						0	10	
Power Supply Rejection Ratio	V _{F6}	ON	ON	OFF	4	-4	0	0	4
	V _{F7}				18	-18			

— Calculation —

1. Input Offset Voltage (V_{IO})
$$V_{IO} = \frac{|V_{F1}|}{1+R_F/R_S} [V]$$

2. Large Signal Voltage Gain (A_V)
$$A_V = 20\text{Log} \frac{\Delta E_K \times (1+R_F/R_S)}{|V_{F2}-V_{F3}|} [dB]$$

3. Common-mode Rejection Ratio (CMRR)
$$\text{CMRR} = 20\text{Log} \frac{\Delta V_{ICM} \times (1+R_F/R_S)}{|V_{F4} - V_{F5}|} [dB]$$

4. Power Supply Rejection Ratio (PSRR)
$$\text{PSRR} = 20\text{Log} \frac{\Delta V_{CC} \times (1+R_F/R_S)}{|V_{F6} - V_{F7}|} [dB]$$

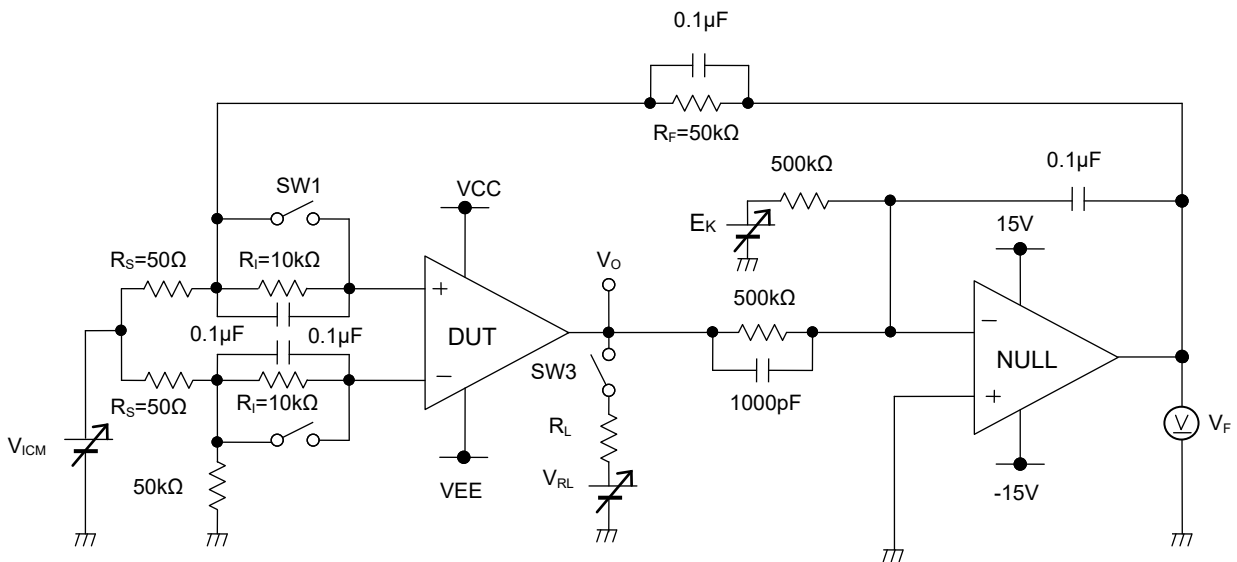

Figure21. Test Circuit 1

Switch Condition for Test Circuit 2

SW No.	SW1	SW2	SW3	SW4	SW5	SW6	SW7	SW8	SW9	SW10	SW11	SW12
Supply Current	OFF	OFF	ON	OFF	ON	OFF	OFF	OFF	OFF	OFF	OFF	OFF
Maximum Output Voltage $R_L=2k\Omega$	OFF	ON	OFF	OFF	ON	OFF	OFF	ON	OFF	OFF	ON	OFF
Slew Rate	OFF	OFF	ON	OFF	OFF	OFF	ON	OFF	ON	OFF	OFF	ON
Maximum Frequency	ON	OFF	OFF	ON	ON	OFF	OFF	OFF	ON	OFF	OFF	ON

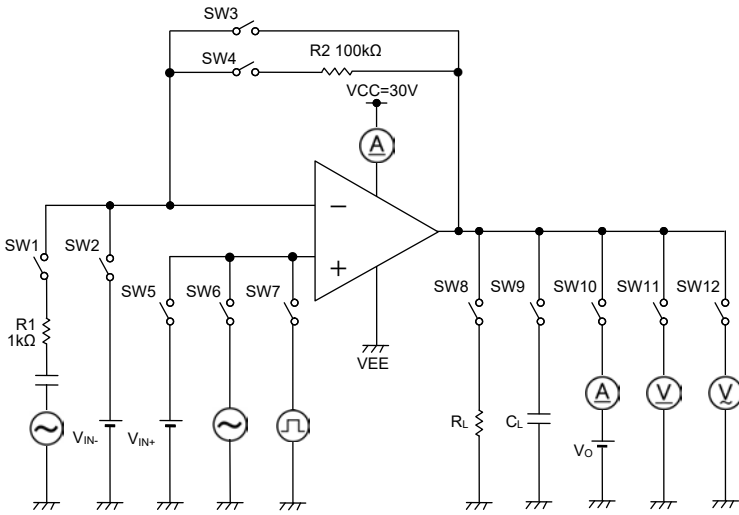

Figure 22. Test Circuit2

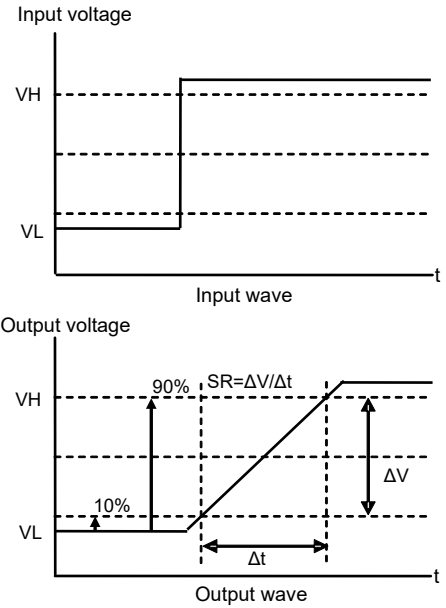

Figure 23. Slew Rate Input Output Wave

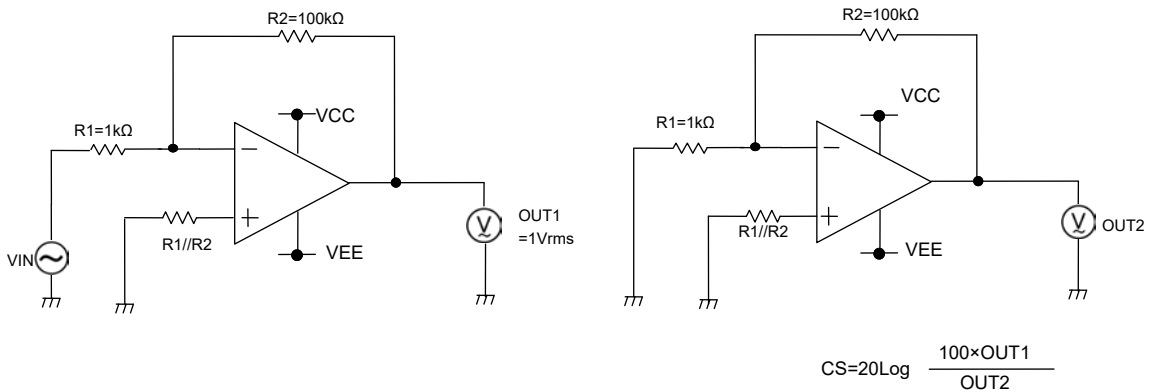

Figure 24. Test Circuit 3 (Channel Separation)

Application Example

○Voltage Follower

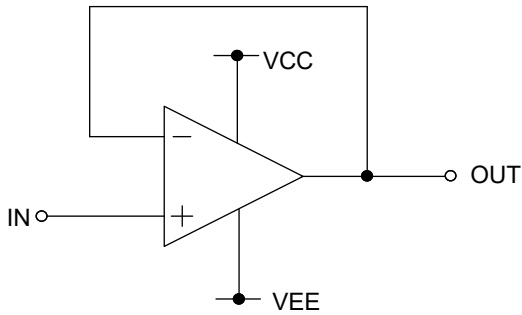

Figure 25. Voltage Follower

Voltage gain is 0dB.

Using this circuit, the output voltage (OUT) is controlled to be equal to the input voltage (IN). This circuit also stabilizes OUT due to high input impedance and low output impedance. Computation for OUT is shown below.

$$OUT=IN$$

○Inverting Amplifier

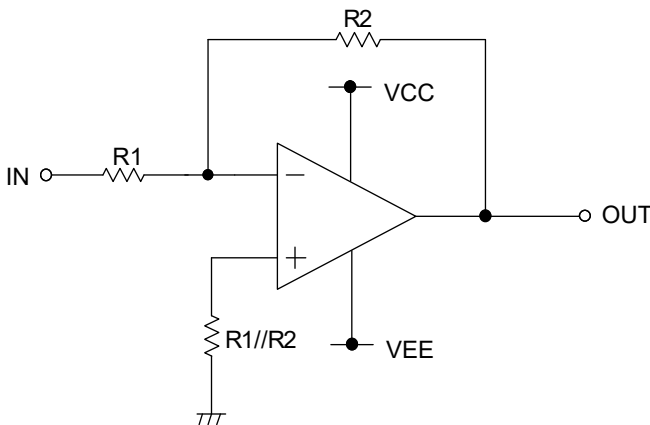

Figure 26. Inverting Amplifier Circuit

For inverting amplifier, IN is amplified by a voltage gain decided by the ratio of R1 and R2. The out-of-phase output voltage is shown in the next expression.

$$OUT=-\left(\frac{R2}{R1}\right) \cdot IN$$

This circuit has input impedance equal to R1.

○Non-inverting amplifier

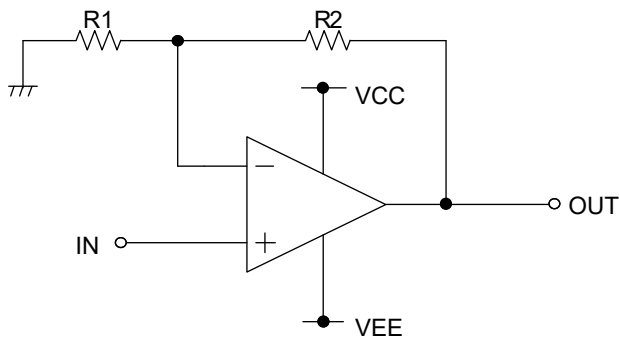

Figure 27. Non-inverting Amplifier Circuit

For non-inverting amplifier, IN is amplified by a voltage gain decided by the ratio of R1 and R2. OUT is in-phase with Vin and is shown in the next expression.

$$OUT=\left(1+\frac{R2}{R1}\right) \cdot IN$$

Effectively, this circuit has high input impedance since its input side is the same as that of the operational amplifier.

Power Dissipation

Power dissipation (total loss) indicates the power that the IC can consume at $T_A=25^{\circ}\text{C}$ (normal temperature). As the IC consumes power, it heats up, causing its temperature to be higher than the ambient temperature. The allowable temperature that the IC can accept is limited. This depends on the circuit configuration, manufacturing process, and consumable power.

Power dissipation is determined by the allowable temperature within the IC (maximum junction temperature) and the thermal resistance of the package used (heat dissipation capability). Maximum junction temperature is typically equal to the maximum storage temperature. The heat generated through the consumption of power by the IC radiates from the mold resin or lead frame of the package. Thermal resistance, represented by the symbol θ_{JA} $^{\circ}\text{C}/\text{W}$, indicates this heat dissipation capability. Similarly, the temperature of an IC inside its package can be estimated by thermal resistance.

Figure 28(a) shows the model of the thermal resistance of the package. The equation below shows how to compute for the Thermal resistance (θ_{JA}), given the ambient temperature (T_A), maximum junction temperature (T_{Jmax}), and power dissipation (P_D).

$$\theta_{JA} = (T_{Jmax} - T_A) / P_D \quad ^{\circ}\text{C}/\text{W} \quad \dots \dots \dots (I)$$

The derating curve in Figure 28(b) indicates the power that the IC can consume with reference to ambient temperature. Power consumption of the IC begins to attenuate at certain temperatures. This gradient is determined by Thermal resistance (θ_{JA}), which depends on the chip size, power consumption, package, ambient temperature, package condition, wind velocity, etc. This may also vary even when the same of package is used. The thermal reduction curve indicates a reference value measured at a specified condition. Figure 28(c) shows an example of the derating curve for LM4565xxx.

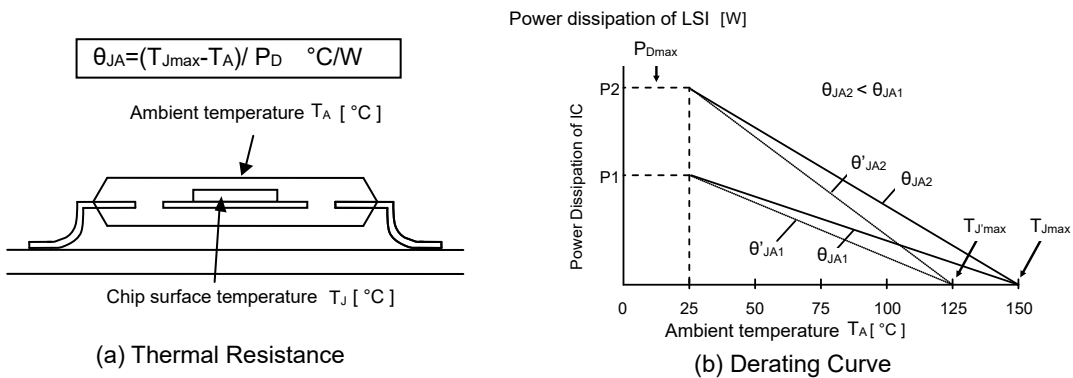

(a) Thermal Resistance

(b) Derating Curve

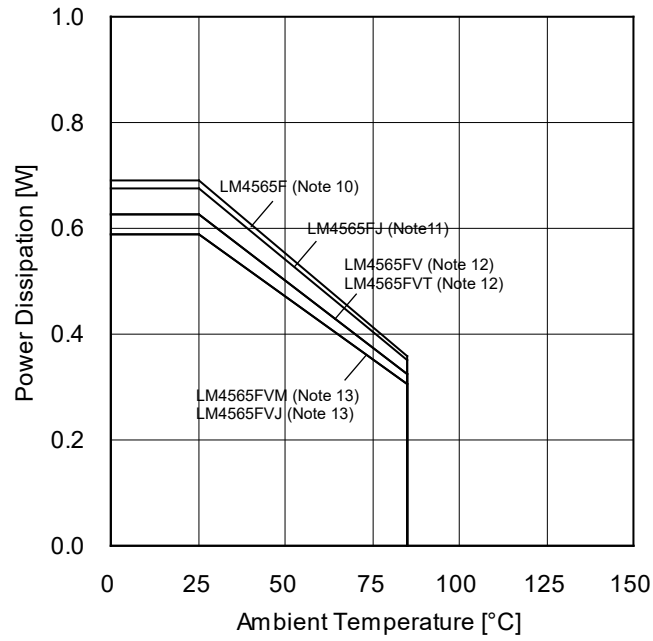

(c) LM4565xxx

(Note 10)	(Note 11)	(Note 12)	(Note 13)	Unit
5.5	5.4	5.0	4.7	mW/°C

When using the unit above $T_A=25^{\circ}\text{C}$, subtract the value above per $^{\circ}\text{C}$. Permissible dissipation is the value when FR4 glass epoxy board 70mm×70mm×1.6mm (copper foil area below 3%) is mounted

Figure 28. Thermal Resistance and Derating Curve

Operational Notes

1. Reverse Connection of Power Supply

Connecting the power supply in reverse polarity can damage the IC. Take precautions against reverse polarity when connecting the power supply, such as mounting an external diode between the power supply and the IC's power supply pins.

2. Power Supply Lines

Design the PCB layout pattern to provide low impedance supply lines. Separate the ground and supply lines of the digital and analog blocks to prevent noise in the ground and supply lines of the digital block from affecting the analog block. Furthermore, connect a capacitor to ground at all power supply pins. Consider the effect of temperature and aging on the capacitance value when using electrolytic capacitors.

3. Ground Voltage

Ensure that no pins are at a voltage below that of the ground pin at any time, even during transient condition.

4. Ground Wiring Pattern

When using both small-signal and large-current ground traces, the two ground traces should be routed separately but connected to a single ground at the reference point of the application board to avoid fluctuations in the small-signal ground caused by large currents. Also ensure that the ground traces of external components do not cause variations on the ground voltage. The ground lines must be as short and thick as possible to reduce line impedance.

5. Thermal Consideration

Should by any chance the power dissipation rating be exceeded the rise in temperature of the chip may result in deterioration of the properties of the chip. The absolute maximum rating of the P_D stated in this specification is when the IC is mounted on a 70mm x 70mm x 1.6mm glass epoxy board. In case of exceeding this absolute maximum rating, increase the board size and copper area to prevent exceeding the P_D rating.

6. Recommended Operating Conditions

These conditions represent a range within which the expected characteristics of the IC can be approximately obtained. The electrical characteristics are guaranteed under the conditions of each parameter.

7. Inrush Current

When power is first supplied to the IC, it is possible that the internal logic may be unstable and inrush current may flow instantaneously due to the internal powering sequence and delays, especially if the IC has more than one power supply. Therefore, give special consideration to power coupling capacitance, power wiring, width of ground wiring, and routing of connections.

8. Operation Under Strong Electromagnetic Field

Operating the IC in the presence of a strong electromagnetic field may cause the IC to malfunction.

9. Testing on Application Boards

When testing the IC on an application board, connecting a capacitor directly to a low-impedance output pin may subject the IC to stress. Always discharge capacitors completely after each process or step. The IC's power supply should always be turned off completely before connecting or removing it from the test setup during the inspection process. To prevent damage from static discharge, ground the IC during assembly and use similar precautions during transport and storage.

10. Inter-pin Short and Mounting Errors

Ensure that the direction and position are correct when mounting the IC on the PCB. Incorrect mounting may result in damaging the IC. Avoid nearby pins being shorted to each other especially to ground, power supply and output pin. Inter-pin shorts could be due to many reasons such as metal particles, water droplets (in very humid environment) and unintentional solder bridge deposited in between pins during assembly to name a few.

Operational Notes – continued

11. Regarding the Input Pin of the IC

This monolithic IC contains P+ isolation and P substrate layers between adjacent elements in order to keep them isolated. P-N junctions are formed at the intersection of the P layers with the N layers of other elements, creating a parasitic diode or transistor. For example (refer to figure below):

When $GND > Pin A$ and $GND > Pin B$, the P-N junction operates as a parasitic diode.

When $GND > Pin B$, the P-N junction operates as a parasitic transistor.

Parasitic diodes inevitably occur in the structure of the IC. The operation of parasitic diodes can result in mutual interference among circuits, operational faults, or physical damage. Therefore, conditions that cause these diodes to operate, such as applying a voltage lower than the GND voltage to an input pin (and thus to the P substrate) should be avoided.

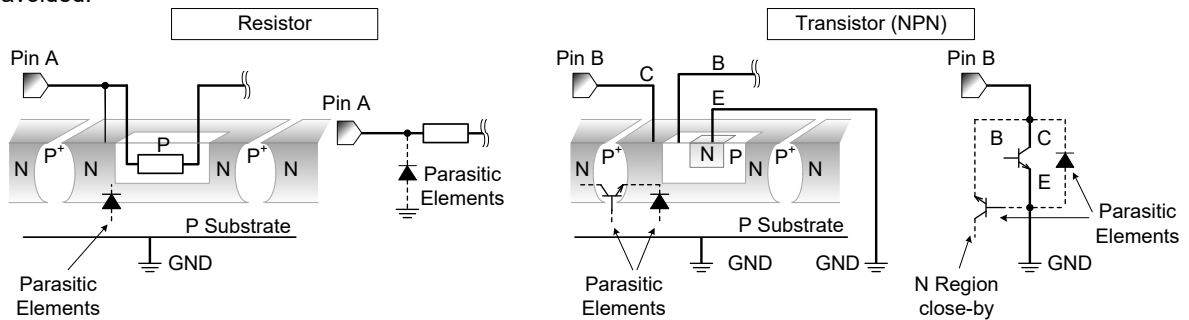

Figure 29. Example of monolithic IC structure

12. Unused Circuits

It is recommended to apply the connection (see Figure 30.) and set the non-inverting input terminal at a potential within the Input Common-mode Voltage Range (V_{ICM}) for any unused circuit.

13. Input Voltage

Applying $VEE +36V$ to the input terminal is possible without causing deterioration of the electrical characteristics or destruction, regardless of the supply voltage. However, this does not ensure normal circuit operation. Please note that the circuit operates normally only when the input voltage is within the common mode input voltage range of the electric characteristics.

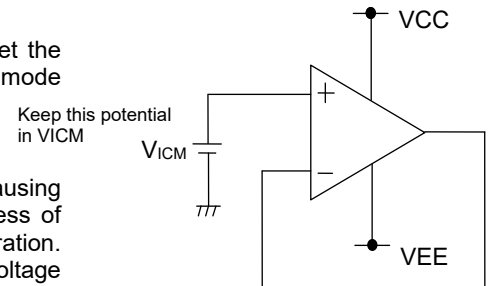

Figure 30. Example of Application Circuit for Unused Op-amp

14. Power Supply(single/dual)

The operational amplifier operates when the voltage supplied is between VCC and VEE. Therefore, the single supply operational amplifier can be used as dual supply operational amplifier as well.

15. IC Handling

When pressure is applied to the IC through warp on the printed circuit board, the characteristics may fluctuate due to the piezo effect. Be careful with the warp on the printed circuit board.

16. The IC Destruction Caused by Capacitive Load

The IC may be damaged when VCC terminal and VEE terminal is shorted with the charged output terminal capacitor. When IC is used as an operational amplifier or as an application circuit where oscillation is not activated by an output capacitor, output capacitor must be kept below $0.1\mu F$ in order to prevent the damage mentioned above.

Physical Dimensions Tape and Reel Information

Package Name	SOP8
--------------	------

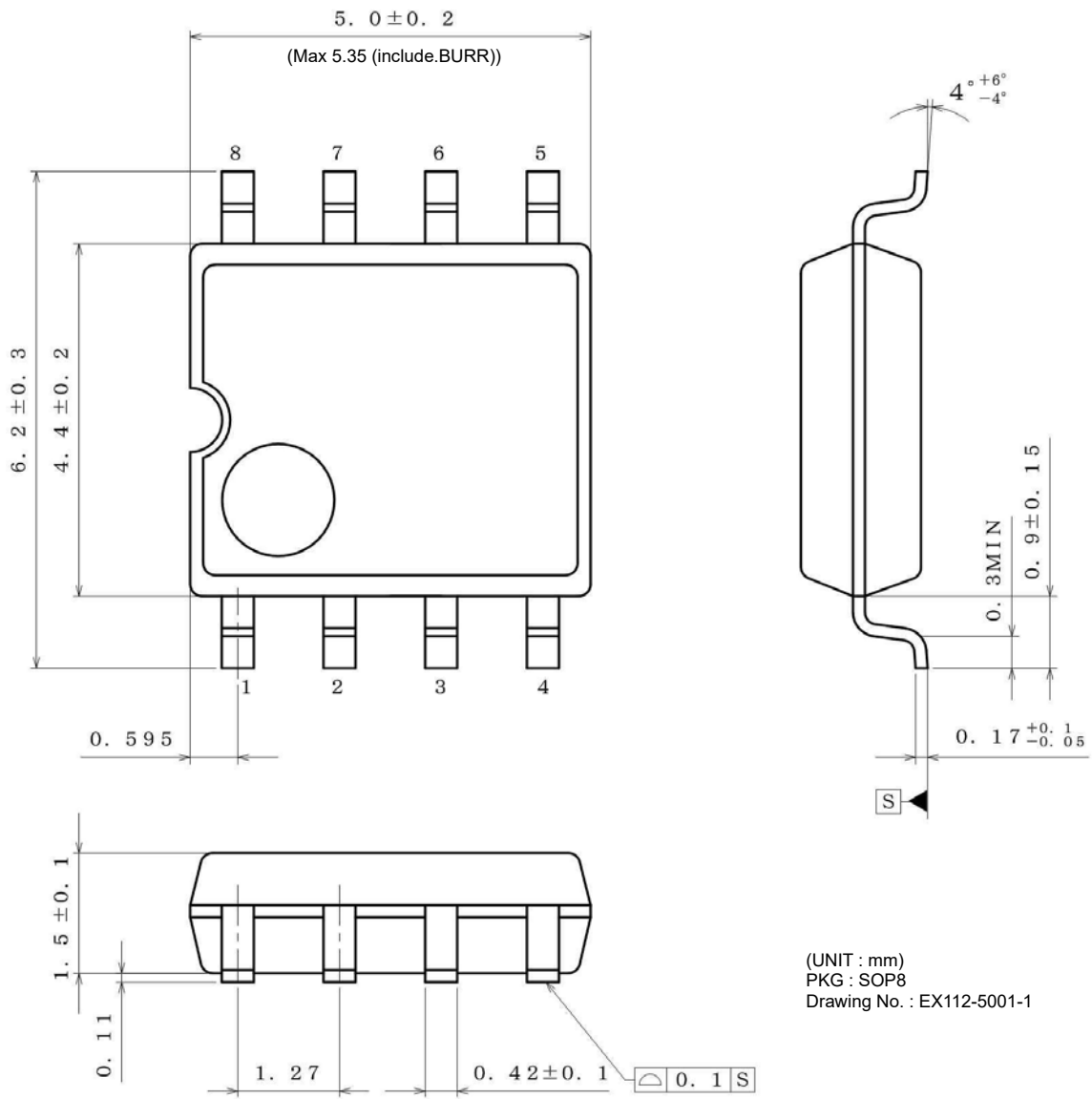

(UNIT : mm)
 PKG : SOP8
 Drawing No. : EX112-5001-1

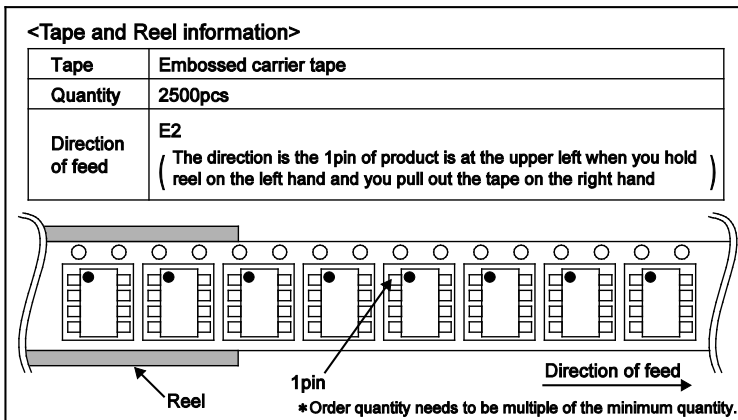

Physical Dimension Tape and Reel Information - continued

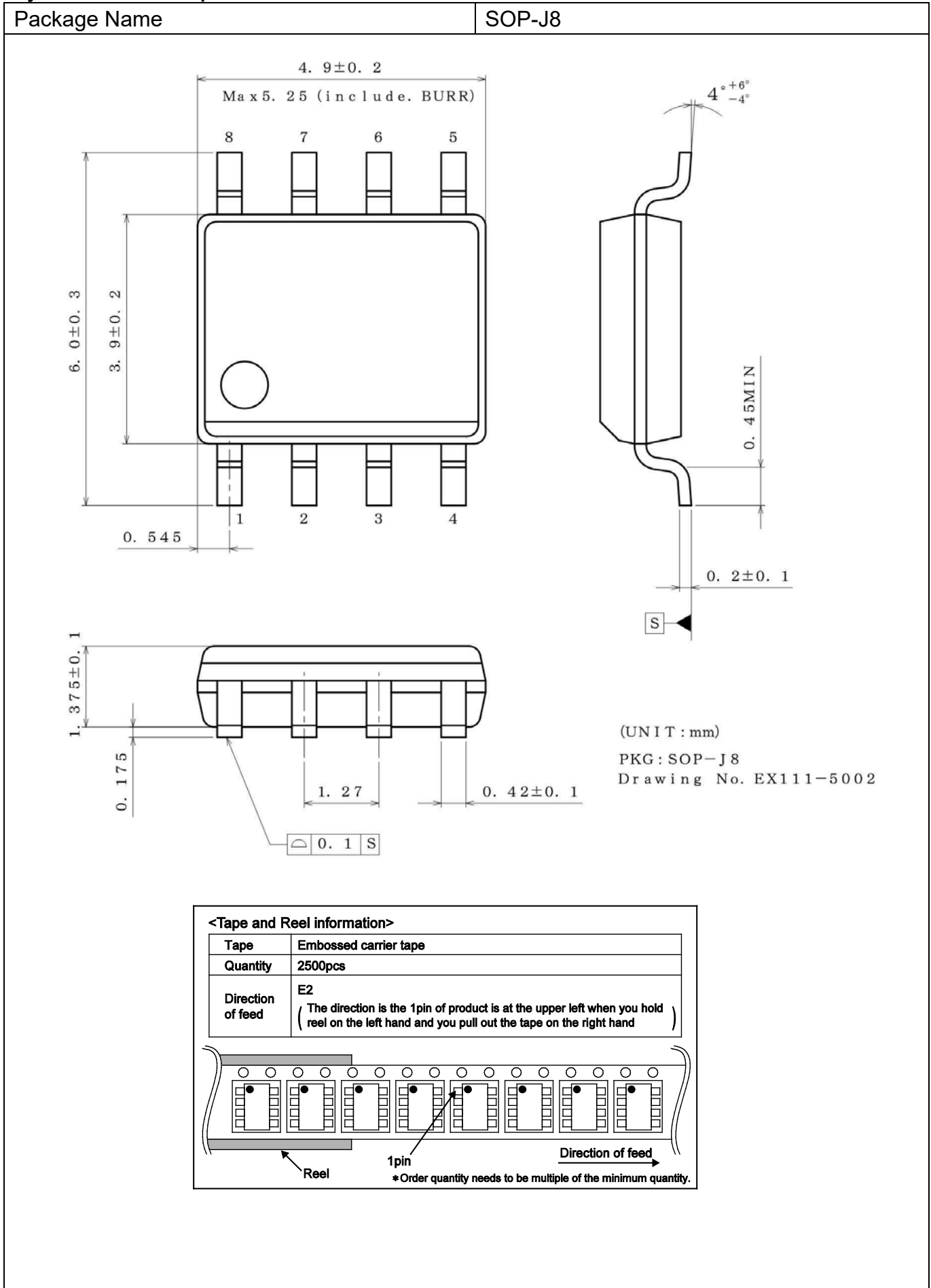

Physical Dimension Tape and Reel Information - continued

Package Name	SSOP-B8
--------------	---------

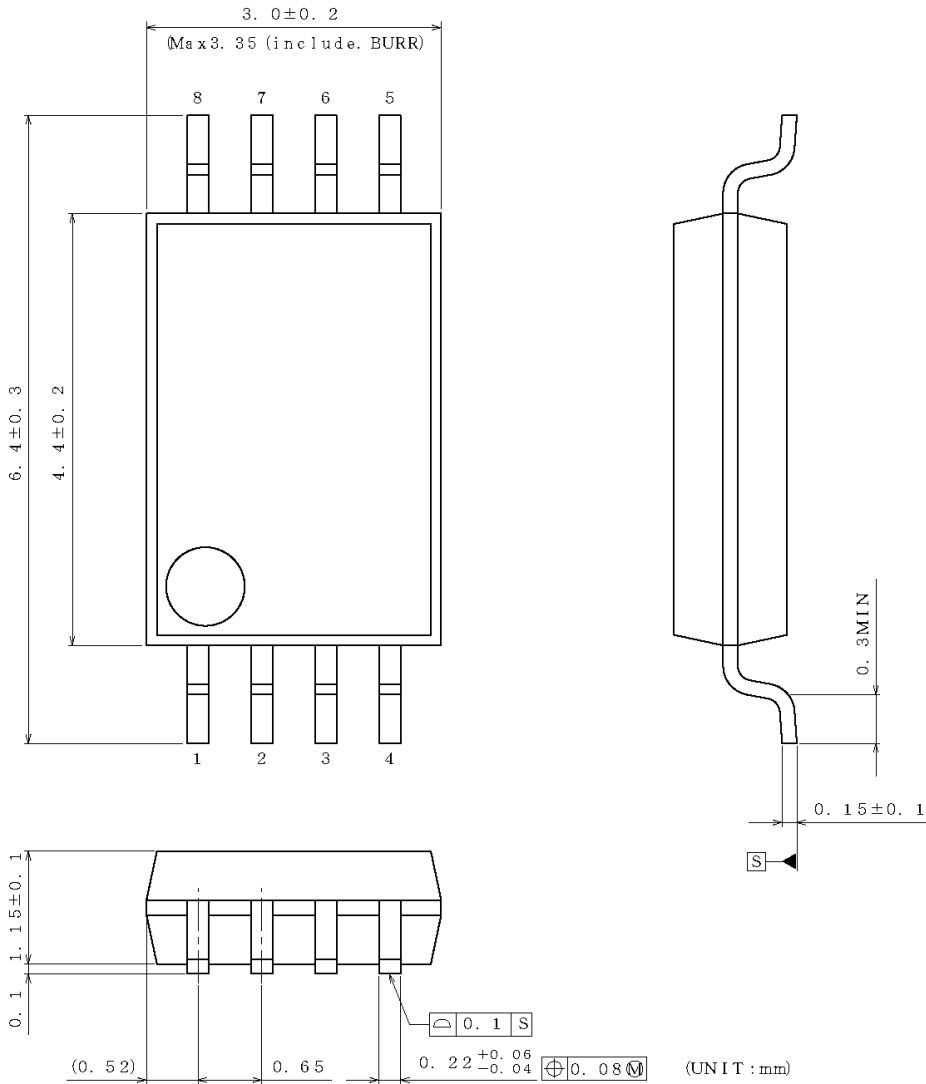

(UNIT : mm)
 PKG : SSOP-B8
 Drawing No. EX151-5002

<Tape and Reel information>

Tape	Embossed carrier tape
Quantity	2500pcs
Direction of feed	E2 (The direction is the 1pin of product is at the upper left when you hold reel on the left hand and you pull out the tape on the right hand)

Diagram of the embossed carrier tape showing the direction of feed and the location of the 1pin. The tape is shown with a series of components. An arrow labeled "Reel" points to the left, and an arrow labeled "Direction of feed" points to the right. A specific pin is labeled "1pin".

*Order quantity needs to be multiple of the minimum quantity.

Physical Dimension Tape and Reel Information - continued

Package Name	TSSOP-B8
--------------	----------

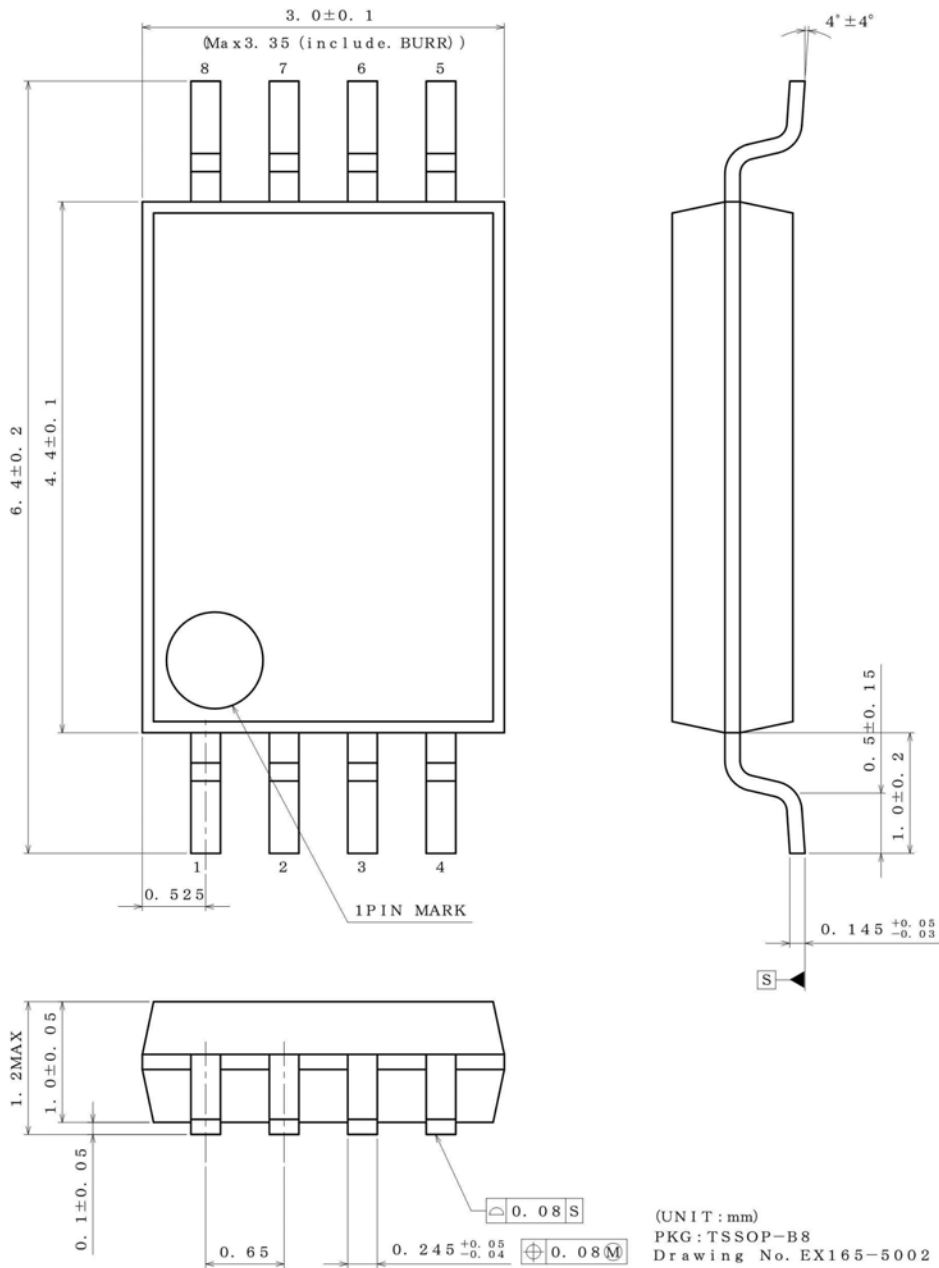

<Tape and Reel information>

Tape	Embossed carrier tape
Quantity	3000pcs
Direction of feed	E2 (The direction is the 1pin of product is at the upper left when you hold reel on the left hand and you pull out the tape on the right hand)

* Order quantity needs to be multiple of the minimum quantity.

Physical Dimension Tape and Reel Information - continued

Package Name	MSOP8
--------------	-------

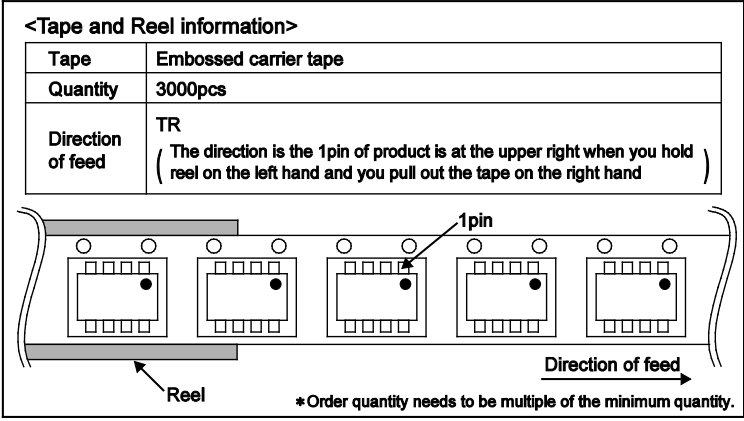
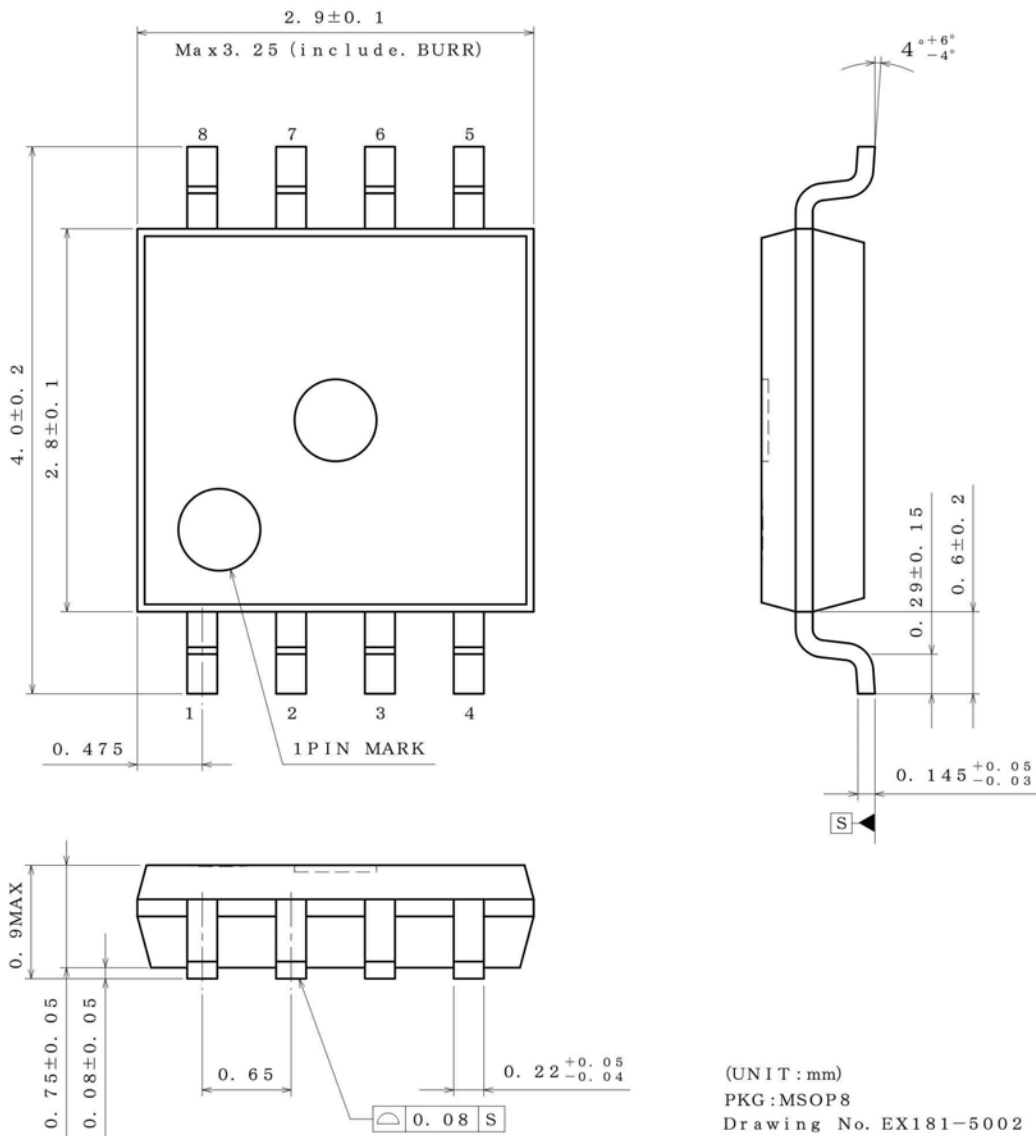

Physical Dimension Tape and Reel Information - continued

Package Name	TSSOP-B8J
--------------	-----------

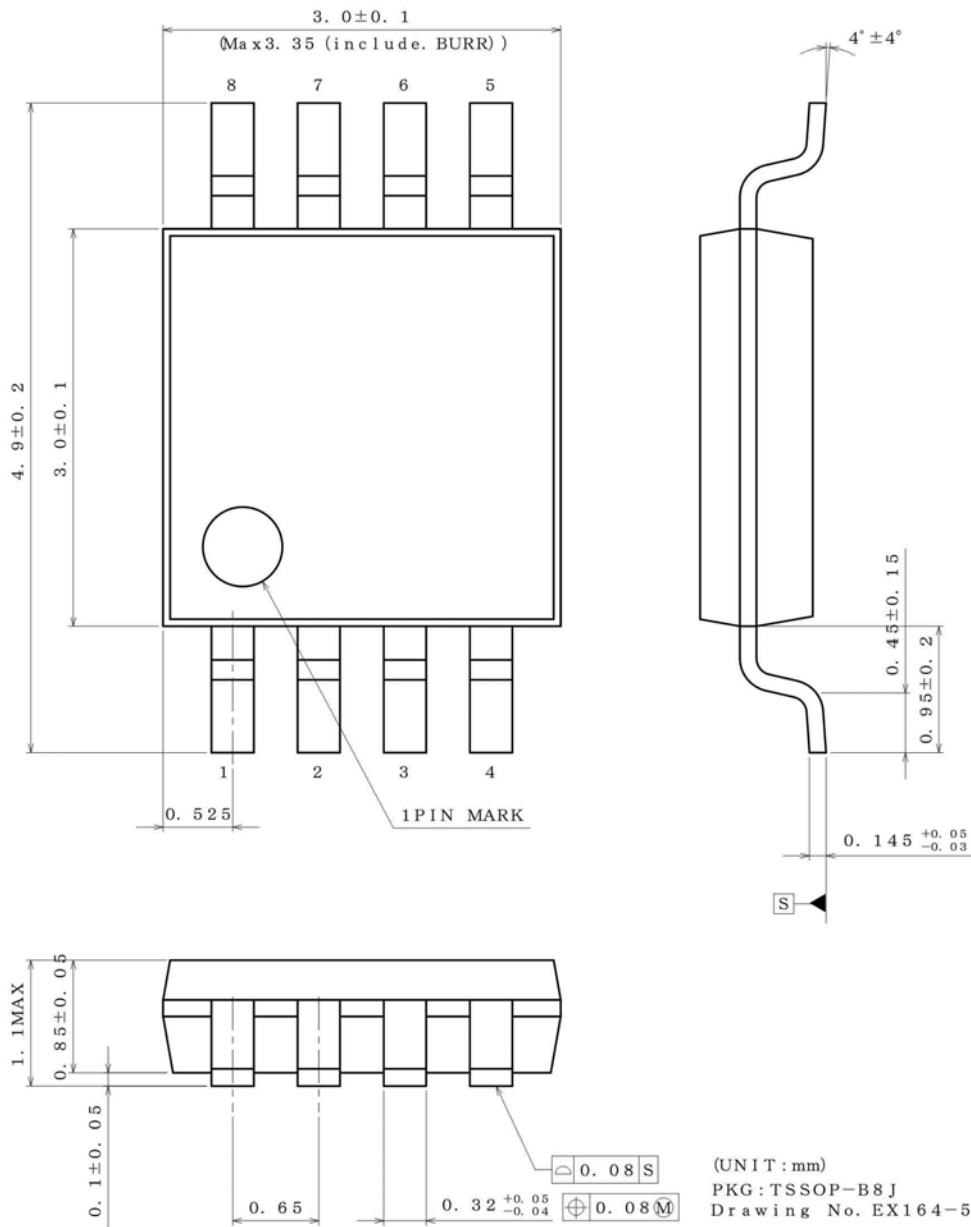

<Tape and Reel information>

Tape	Embossed carrier tape
Quantity	2500pcs
Direction of feed	E2 (The direction is the 1pin of product is at the upper left when you hold reel on the left hand and you pull out the tape on the right hand)

* Order quantity needs to be multiple of the minimum quantity.

Marking Diagram

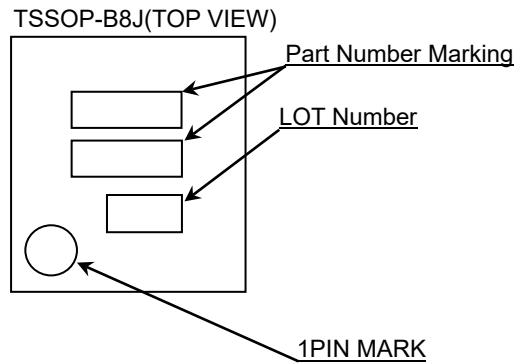
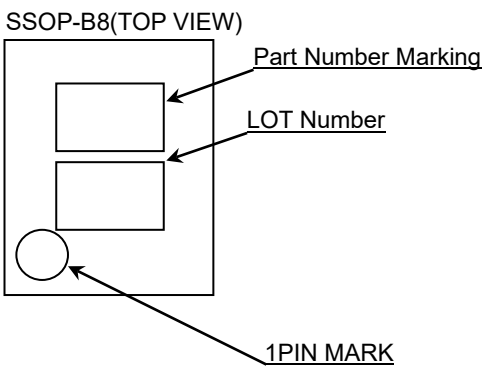
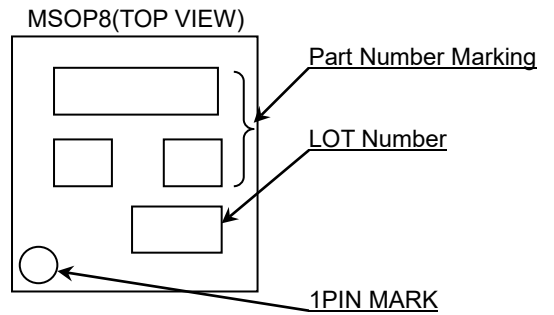
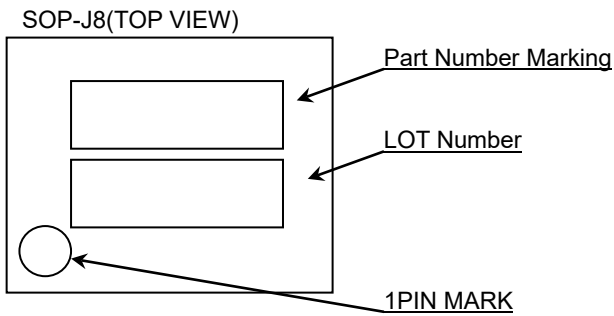
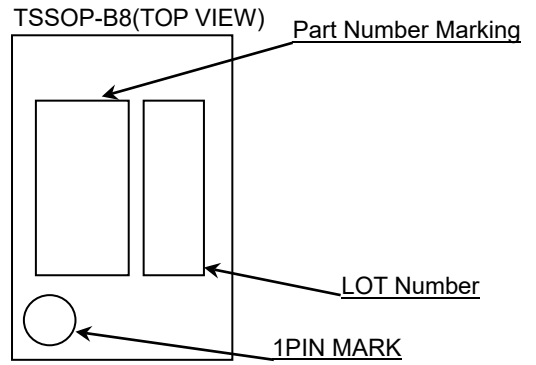
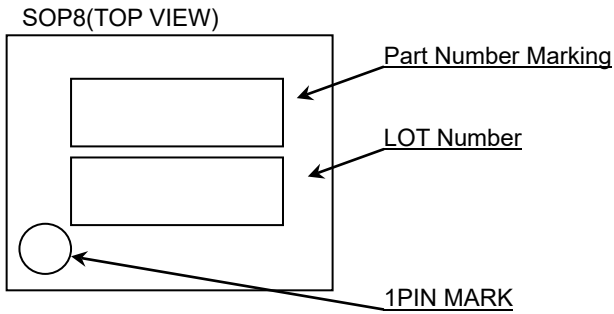

Product Name		Package Type	Marking
LM4565	F	SOP8	4565
	FJ	SOP-J8	L4565
	FV	SSOP-B8	4565
	FVT	TSSOP-B8	L4565
	FVM	MSOP8	L4565
	FVJ	TSSOP-B8J	L4565

Land Pattern Data

All dimensions in mm

PKG	Land pitch e	Land space MIE	Land length $\geq \ell 2$	Land width b2
SOP8	1.27	4.60	1.10	0.76
SOP-J8	1.27	3.90	1.35	0.76
SSOP-B8	0.65	4.60	1.20	0.35
TSSOP-B8	0.65	4.60	1.20	0.35
MSOP8	0.65	2.62	0.99	0.35
TSSOP-B8J	0.65	3.20	1.15	0.35

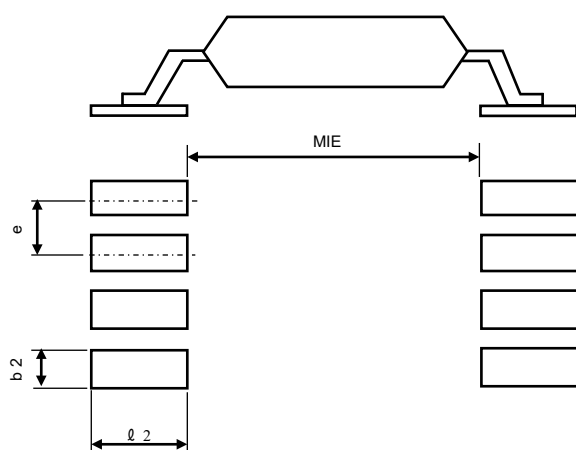

Revision History

Date	Revision	Changes
30.Nov.2012	001	New Release
2.Sep.2013	002	Added LM4565FV, LM4565FJ, LM4565FVT, LM4565FVM, LM4565FVJ
15.Apr.2014	003	The Operating Supply Voltage Range is changed.
08.May.2024	004	Correct spelling mistakes

Notice

Precaution on using ROHM Products

- Our Products are designed and manufactured for application in ordinary electronic equipment (such as AV equipment, OA equipment, telecommunication equipment, home electronic appliances, amusement equipment, etc.). If you intend to use our Products in devices requiring extremely high reliability (such as medical equipment ^(Note 1), transport equipment, traffic equipment, aircraft/spacecraft, nuclear power controllers, fuel controllers, car equipment including car accessories, safety devices, etc.) and whose malfunction or failure may cause loss of human life, bodily injury or serious damage to property ("Specific Applications"), please consult with the ROHM sales representative in advance. Unless otherwise agreed in writing by ROHM in advance, ROHM shall not be in any way responsible or liable for any damages, expenses or losses incurred by you or third parties arising from the use of any ROHM's Products for Specific Applications.

(Note1) Medical Equipment Classification of the Specific Applications

JAPAN	USA	EU	CHINA
CLASS III	CLASS III	CLASS II b	CLASS III
CLASS IV		CLASS III	

- ROHM designs and manufactures its Products subject to strict quality control system. However, semiconductor products can fail or malfunction at a certain rate. Please be sure to implement, at your own responsibilities, adequate safety measures including but not limited to fail-safe design against the physical injury, damage to any property, which a failure or malfunction of our Products may cause. The following are examples of safety measures:
 - Installation of protection circuits or other protective devices to improve system safety
 - Installation of redundant circuits to reduce the impact of single or multiple circuit failure
- Our Products are designed and manufactured for use under standard conditions and not under any special or extraordinary environments or conditions, as exemplified below. Accordingly, ROHM shall not be in any way responsible or liable for any damages, expenses or losses arising from the use of any ROHM's Products under any special or extraordinary environments or conditions. If you intend to use our Products under any special or extraordinary environments or conditions (as exemplified below), your independent verification and confirmation of product performance, reliability, etc. prior to use, must be necessary:
 - Use of our Products in any types of liquid, including water, oils, chemicals, and organic solvents
 - Use of our Products outdoors or in places where the Products are exposed to direct sunlight or dust
 - Use of our Products in places where the Products are exposed to sea wind or corrosive gases, including Cl₂, H₂S, NH₃, SO₂, and NO₂
 - Use of our Products in places where the Products are exposed to static electricity or electromagnetic waves
 - Use of our Products in proximity to heat-producing components, plastic cords, or other flammable items
 - Sealing or coating our Products with resin or other coating materials
 - Use of our Products without cleaning residue of flux (Exclude cases where no-clean type fluxes is used. However, recommend sufficiently about the residue.) ; or Washing our Products by using water or water-soluble cleaning agents for cleaning residue after soldering
 - Use of the Products in places subject to dew condensation
- The Products are not subject to radiation-proof design.
- Please verify and confirm characteristics of the final or mounted products in using the Products.
- In particular, if a transient load (a large amount of load applied in a short period of time, such as pulse, is applied, confirmation of performance characteristics after on-board mounting is strongly recommended. Avoid applying power exceeding normal rated power; exceeding the power rating under steady-state loading condition may negatively affect product performance and reliability.
- De-rate Power Dissipation depending on ambient temperature. When used in sealed area, confirm that it is the use in the range that does not exceed the maximum junction temperature.
- Confirm that operation temperature is within the specified range described in the product specification.
- ROHM shall not be in any way responsible or liable for failure induced under deviant condition from what is defined in this document.

Precaution for Mounting / Circuit board design

- When a highly active halogenous (chlorine, bromine, etc.) flux is used, the residue of flux may negatively affect product performance and reliability.
- In principle, the reflow soldering method must be used on a surface-mount products, the flow soldering method must be used on a through hole mount products. If the flow soldering method is preferred on a surface-mount products, please consult with the ROHM representative in advance.

For details, please refer to ROHM Mounting specification

Precautions Regarding Application Examples and External Circuits

1. If change is made to the constant of an external circuit, please allow a sufficient margin considering variations of the characteristics of the Products and external components, including transient characteristics, as well as static characteristics.
2. You agree that application notes, reference designs, and associated data and information contained in this document are presented only as guidance for Products use. Therefore, in case you use such information, you are solely responsible for it and you must exercise your own independent verification and judgment in the use of such information contained in this document. ROHM shall not be in any way responsible or liable for any damages, expenses or losses incurred by you or third parties arising from the use of such information.

Precaution for Electrostatic

This Product is electrostatic sensitive product, which may be damaged due to electrostatic discharge. Please take proper caution in your manufacturing process and storage so that voltage exceeding the Products maximum rating will not be applied to Products. Please take special care under dry condition (e.g. Grounding of human body / equipment / solder iron, isolation from charged objects, setting of Ionizer, friction prevention and temperature / humidity control).

Precaution for Storage / Transportation

1. Product performance and soldered connections may deteriorate if the Products are stored in the places where:
 - [a] the Products are exposed to sea winds or corrosive gases, including Cl₂, H₂S, NH₃, SO₂, and NO₂
 - [b] the temperature or humidity exceeds those recommended by ROHM
 - [c] the Products are exposed to direct sunshine or condensation
 - [d] the Products are exposed to high Electrostatic
2. Even under ROHM recommended storage condition, solderability of products out of recommended storage time period may be degraded. It is strongly recommended to confirm solderability before using Products of which storage time is exceeding the recommended storage time period.
3. Store / transport cartons in the correct direction, which is indicated on a carton with a symbol. Otherwise bent leads may occur due to excessive stress applied when dropping of a carton.
4. Use Products within the specified time after opening a humidity barrier bag. Baking is required before using Products of which storage time is exceeding the recommended storage time period.

Precaution for Product Label

A two-dimensional barcode printed on ROHM Products label is for ROHM's internal use only.

Precaution for Disposition

When disposing Products please dispose them properly using an authorized industry waste company.

Precaution for Foreign Exchange and Foreign Trade act

Since concerned goods might be fallen under listed items of export control prescribed by Foreign exchange and Foreign trade act, please consult with ROHM in case of export.

Precaution Regarding Intellectual Property Rights

1. All information and data including but not limited to application example contained in this document is for reference only. ROHM does not warrant that foregoing information or data will not infringe any intellectual property rights or any other rights of any third party regarding such information or data.
2. ROHM shall not have any obligations where the claims, actions or demands arising from the combination of the Products with other articles such as components, circuits, systems or external equipment (including software).
3. No license, expressly or implied, is granted hereby under any intellectual property rights or other rights of ROHM or any third parties with respect to the Products or the information contained in this document. Provided, however, that ROHM will not assert its intellectual property rights or other rights against you or your customers to the extent necessary to manufacture or sell products containing the Products, subject to the terms and conditions herein.

Other Precaution



1. This document may not be reprinted or reproduced, in whole or in part, without prior written consent of ROHM.
2. The Products may not be disassembled, converted, modified, reproduced or otherwise changed without prior written consent of ROHM.
3. In no event shall you use in any way whatsoever the Products and the related technical information contained in the Products or this document for any military purposes, including but not limited to, the development of mass-destruction weapons.
4. The proper names of companies or products described in this document are trademarks or registered trademarks of ROHM, its affiliated companies or third parties.

General Precaution

1. Before you use our Products, you are requested to carefully read this document and fully understand its contents. ROHM shall not be in any way responsible or liable for failure, malfunction or accident arising from the use of any ROHM's Products against warning, caution or note contained in this document.
2. All information contained in this document is current as of the issuing date and subject to change without any prior notice. Before purchasing or using ROHM's Products, please confirm the latest information with a ROHM sales representative.
3. The information contained in this document is provided on an "as is" basis and ROHM does not warrant that all information contained in this document is accurate and/or error-free. ROHM shall not be in any way responsible or liable for any damages, expenses or losses incurred by you or third parties resulting from inaccuracy or errors of or concerning such information.

Looking for pricing, stock, or lifecycle information?

Click below to explore more details on WIN SOURCE:

-  [View LM4565FV-GE2 on WIN SOURCE](#)
-  [Rohm Semiconductor](#) Information

Optimize Your Supply Chain with WIN SOURCE Solutions

-  Global Sourcing Solution
-  Obsolete Management
-  Cost Control Management
-  Shortage Management
-  Alternative Solution
-  Excess Inventory Management