



**THE DATASHEET OF  
LM3406HVEVAL/NOPB**



## AN-1993 LM3406HV Evaluation Board with 2 Wire Dimming

### 1 Introduction

The LM3406HV is a buck regulator controlled current source designed to drive a series string of high power, high brightness LEDs (HBLEDs) such as the Luxeon™ K2 Emitter at forward currents of up to 1.5A. The converter's output voltage adjusts as needed to maintain a constant current through the LED array.

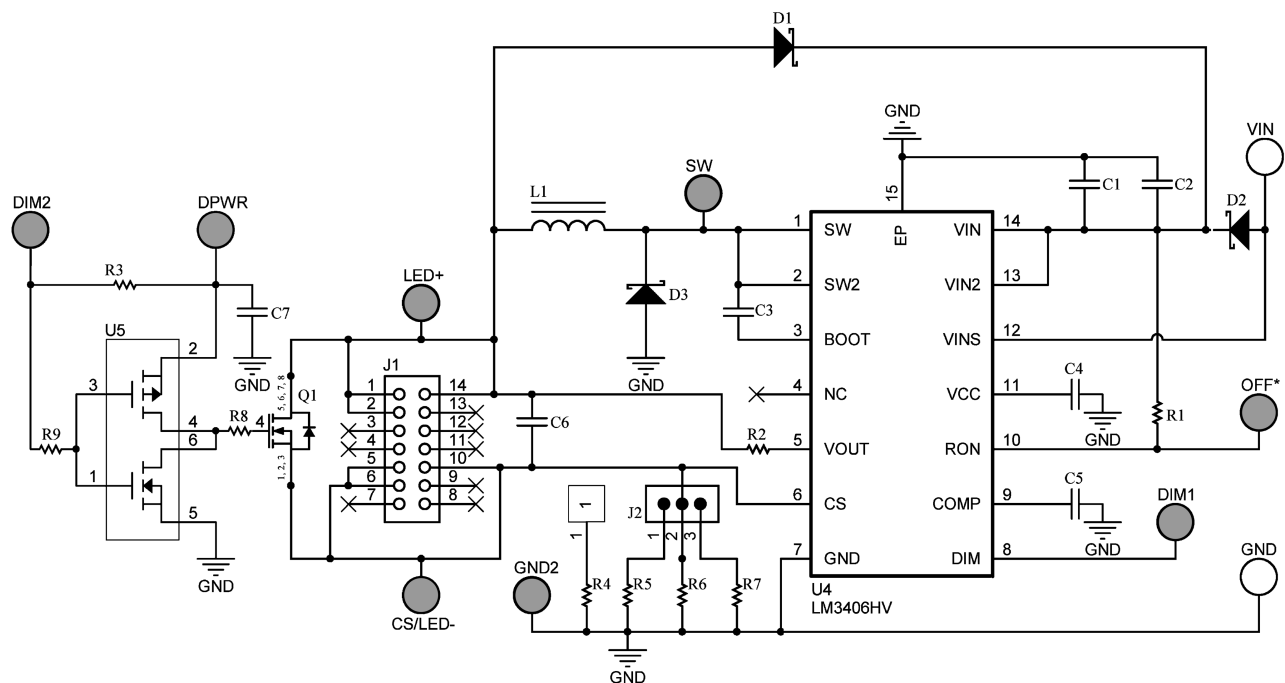

**Figure 1. Complete Circuit Schematic**

## 2 Circuit Performance

The LM3406HV circuit and BOM that come pre-installed on the evaluation board are optimized to run from an input voltage of 24V, but the circuit can operate from a wide input voltage range of 6.0V to 75V. The current output ranges from 0.35A to 1.5A. Figure 2 shows the program jumper settings used to program currents of 0.35A, 0.7A, 1A, and 1.5A.

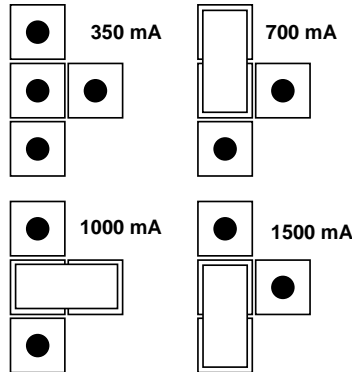

Figure 2. Setting Output Current, J2

The LM3406HV is a step-down regulator with an output voltage range extending from a  $V_{O-MIN}$  of 200 mV (the reference voltage) to a  $V_{O-MAX}$  determined by the ratio of the minimum off time (typically 230 ns) to the switching frequency. The regulator can maintain the output current through any number of LEDs as long as the combined forward voltage of the array does not exceed  $V_{O-MAX}$ .  $V_{O-MAX}$  can be calculated with the following formula:

$$V_{O-MAX} = V_{IN-MIN} \times (1 - f_{SW} \times t_{OFF-MIN}) \tag{1}$$

For example, if  $V_{IN}$  is 24V  $\pm 10\%$ , then  $V_{IN-MIN}$  is 21.6V. For a switching frequency of 500 kHz the maximum output voltage for the converter is  $21.6 \times [1 - (5 \times 10^5) \times (230 \times 10^{-9})] = 19.1V$ . Output voltage is calculated with the following formula:

$$V_o = n \times V_F + 0.2V$$

where

- $n$  is the number of series-connected LEDs
- $V_F$  is the forward voltage of each LED
- 0.2V represents the voltage across the current sense resistor

For InGaN LEDs (white, blue, blue-green)  $V_F$  is typically 3.5V, and with a limit of  $(19.1 - 0.2) = 18.9V$  the LM3406HV could drive as many as five in series. For AlInGaP LEDs (red, orange, amber)  $V_F$  is typically 2.5V, so a  $V_{O-MAX}$  of 18.9V would allow as many as seven to be driven in series.

## 3 Connecting the LED Array

The LM3406HV Evaluation Board includes test posts for connecting the LED/LED Array. Connect the open anode of the array to LED+ and the cathode of the array to CS/LED-. Keep the leads from the board to the LED(s) as short as possible to minimize inductance.

## 4 Setting the LED Current

The default forward current  $I_F$  delivered to the LED array when no program jumper is installed on **J2** is 0.35A, set by resistor **R6**. The higher LED currents are set when the program jumper puts resistors **R4**, **R5** or **R7** in parallel with **R6**. For users that wish to program a current other than one of the four default levels, or for users who want the best accuracy at a given current, the program jumper **J2** should be removed, and **R6** changed according to the following equation:

$$R.35 = 0.2 / I_F \quad (3)$$

This resistor should be rated to handle the power dissipation of the LED current. For example, the closest 5% tolerance resistor to set an LED current of 0.35A is 0.56Ω. In steady state this resistor will dissipate  $(0.35^2 \times 0.56) = 69$  mW, indicating that a resistor with a 1/8W rating is more than capable of dissipating the power.

## 5 Pulse Width Modulation (PWM) Dimming

The **DIM1** terminal on the PCB provides an input for a logic-level pulse width modulation signal for dimming of the LED array. In order to fully enable and disable the LM3406HV the PWM signal should have a maximum logic low level of 0.8V and a minimum logic high level of 2.2V. Graphical representations of minimum and maximum PWM duty cycle are illustrated in [Figure 3](#). The interval  $t_D$  represents the delay from a logic high at the DIM pin to the rise in output current. The quantities  $t_{SU}$  and  $t_{SD}$  represent the time needed for the output current to slew up to steady state and slew down to zero, respectively. It is important to note that  $t_D$  is a property of the LM3406HV and remains fixed in all applications. The slew rates  $t_{SU}$  and  $t_{SD}$  are a function of the external circuit parameters  $V_{IN}$ ,  $V_O$ ,  $I_F$ , inductance (L) and the LM3406HV parameter  $t_{OFF-MIN}$ . Response times for a circuit driving three white LEDs at 1A from 24V are shown in the [Typical Performance Characteristics](#) section, but the user should test every new circuit to determine the actual PWM dimming response.

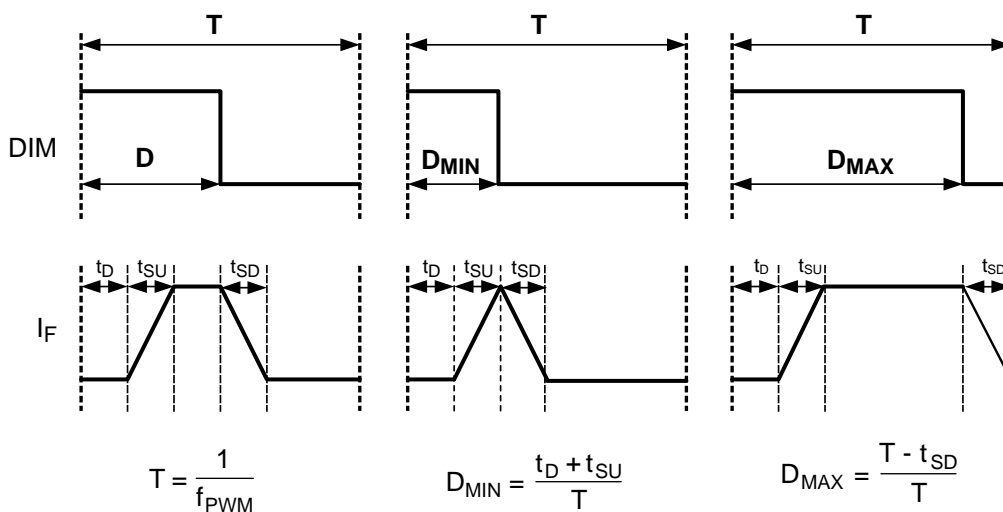

Figure 3. PWM Dimming Limits

The logic of **DIM1** is active low, hence the LM3406HV will deliver regulated output current when the voltage at **DIM1** is high, and the current output is disabled when the voltage at **DIM1** is low. Connecting a constant logic low will disable the output. Note that an internal pullup ensures that the LM3406HV is enabled if the DIM pin is open-circuited. The **DIM1** function disables only the power MOSFET, leaving all other circuit blocks functioning to minimize the converter response time,  $t_D$ .

The **DIM2** terminal provides a second method for PWM dimming by connecting to the gate of MOSFET **Q1** through the driver **U5**. **Q1** provides a parallel path for the LED current. Shunting the output current through a parallel MOSFET reduces the PWM dimming delays because the inductor current remains continuous, providing faster response time for higher frequency and/or greater resolution in the PWM dimming signal. The trade-off in this method is that the full current flows through **Q1** while the LED is off, resulting in lower efficiency. The LM3406HV evaluation board includes an output capacitor to reduce output current ripple which is not initially populated, but the drawback of this output capacitor if used is that it causes significant delays when using parallel MOSFET dimming. The output capacitor should be removed to take full advantage of parallel MOSFET dimming.

The logic of **DIM2** is active low, hence the regulated output current flows through the LED array when the voltage at **DIM2** is high, and the current flows through the shunt FET when the voltage at **DIM2** is low. Connecting a constant logic low to the **DIM2** will turn off the LED but will not shut down the LM3406HV. A voltage of up to 30V must be applied to the **DPWR** pin to operate U5.

## 6 2 Wire Input Dimming

The LM3406HV evaluation board has been designed for 2 wire dimming for systems that present a square wave input voltage for dimming purposes. A diode, D2, separates the VIN pins from the VINS pin. When the input voltage at VINS falls to 70% or less of the voltage at VIN the device stops switching and enters dim mode. The capacitors C1 and C2 hold up the voltage at the VIN pins during this time so that the LM3406HV is enabled and responds quickly when the voltage at VINS again exceeds 70% of the voltage at VIN.

## 7 Low Power Shutdown

The LM3406HV can be placed into a low power shutdown (typically 240  $\mu\text{A}$ ) by grounding the **OFF\*** terminal. During normal operation this terminal should be left open-circuit.

## 8 Output Open Circuit

The LM3406HV will begin to operate as soon as VIN is greater than 6V and the DIM and RON pins are not grounded. If the regulator is powered and enabled but no LED array is connected, the output voltage will rise to  $V_{IN}$ . The output of the circuit is rated to 50V (beyond the maximum input voltage) and will not suffer damage, however care should be taken not to connect an LED array if the output voltage is higher than the target forward voltage of the LED array in steady state.

If the LEDs are disconnected or one of the LEDs fails open-circuit while the LM3406HV is operating, the output voltage will experience a surge as the current in the output inductor seeks a discharge path. The output capacitor (if present) can absorb some of this energy, however circuits with little or no output capacitance can experience a voltage spike that exceeds the rating of the VOUT pin. The evaluation board uses a 10 k $\Omega$  resistor in series with the VOUT pin to limit current flowing into the pin. Alternatively, a diode connected from  $V_{IN}$  to  $V_O$  as shown in Figure 4 will clamp the spike to  $V_{IN}$  plus a diode drop and is included on the evaluation board.

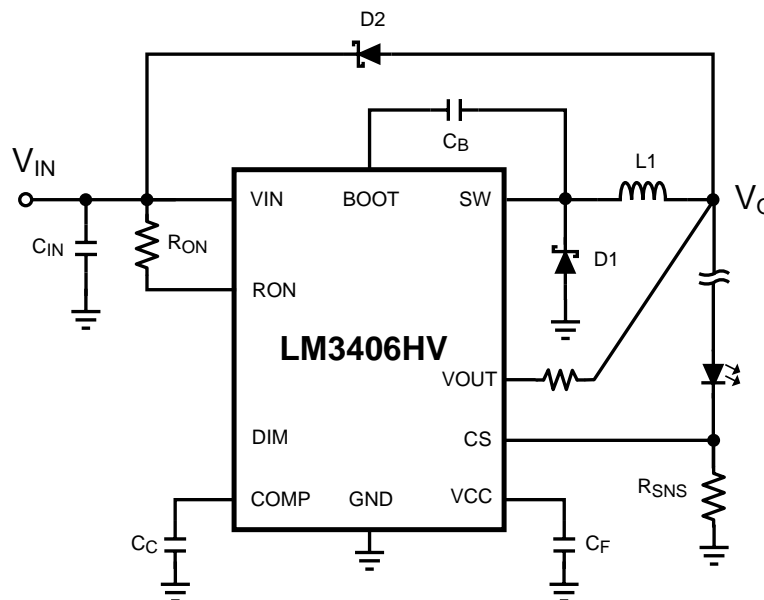

Figure 4. Schottky Diode Protection for Open-Circuit

## 9 Bill of Materials

ID	Part Number	Type	Size	Parameters	Qty	Vendor
U1	LM3406HV	Buck LED Driver	TSSOP-14	75V, 1.5A	1	NSC
U5	FDC6333C	MOSFET N-CH/P-CH	SSOT-6	30V, 2.5A	1	Fairchild Semiconductor
D1	B1100-13-F	Schottky Diode	SMA	100V, 1A	1	Diodes Inc.
D2, D3	MBRS3100T3G	Schottky Diode	SMC	100V, 3A	2	ON Semiconductor
Q1	SI4464DY-E3	MOSFET	SOIC-8	200V, 1.7A	1	Vishay
C1 C2	C5750X7R2A475M	Capacitor	2220	4.7 $\mu$ F, 100V	2	TDK
C3	GRM188R71C223K01D	Capacitor	0603	0.022 $\mu$ F, 16V	1	Murata
C4, C5, C7	GRM188R71C104K01D	Capacitor	0603	0.1 $\mu$ F, 16V	3	Murata
C6		Capacitor	1812	OPEN		
L1	MSS1038-333MLB	Inductor	MSS1038	33 $\mu$ H, 1.8A	1	Coilcraft
R1	CRCW0805143kFKA	Resistor	0805	143 k $\Omega$ 1%	1	Vishay
R2	CRCW06031K00JNEA	Resistor	0603	1 k $\Omega$ 5%	1	Vishay
R3	CRCW060310k0FKA	Resistor	0603	10 k $\Omega$ 1%	1	Vishay
R4	ERJ-6RQFR30V	Resistor	0805	0.3 $\Omega$ 1%	1	Panasonic
R5	ERJ-6RQFR16V	Resistor	0805	0.16 $\Omega$ 1%	1	Panasonic
R6	ERJ-6RQFR56V	Resistor	0805	0.56 $\Omega$ 1%	1	Panasonic
R7	ERJ-6RQFR62V	Resistor	0805	0.62 $\Omega$ 1%	1	Panasonic
R8, R9	CRCW06031R00FNEA	Resistor	0603	1 $\Omega$ 1%	2	Vishay
CS/LED-, DIM1, DIM2, DPWR, GND2, LED+, OFF*, SW	1502-2	Terminal	Keystone 1598-2		8	Keystone
VIN, GND	575-8	Terminal	575-8		2	Keystone

## 10 Typical Performance Characteristics

$V_{IN} = 24V$ ,  $I_F = 1A$ ,  $T_A = 25^\circ C$ , and the load consists of three InGaN LEDs in series unless otherwise noted.

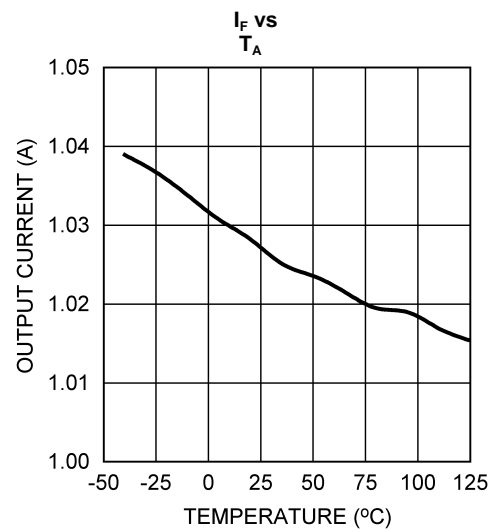
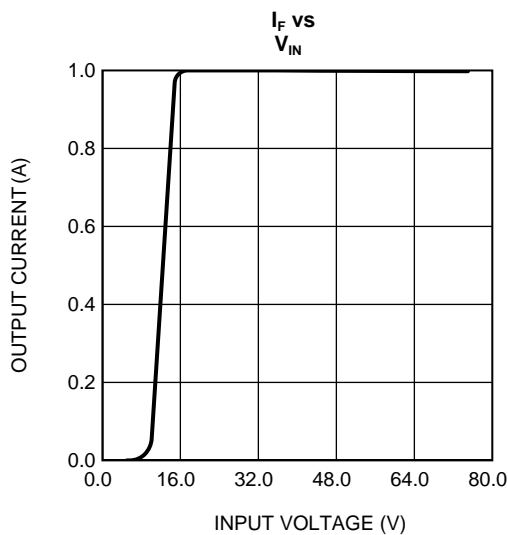
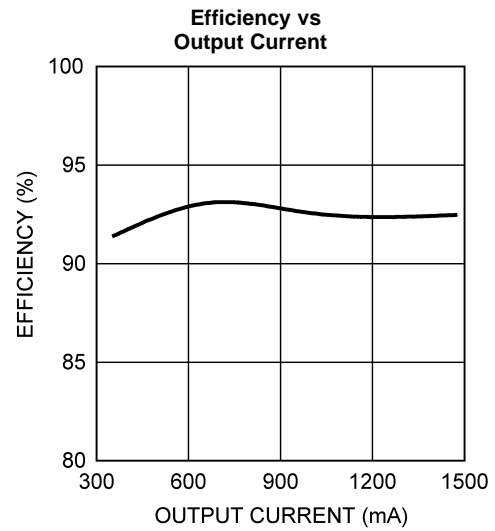
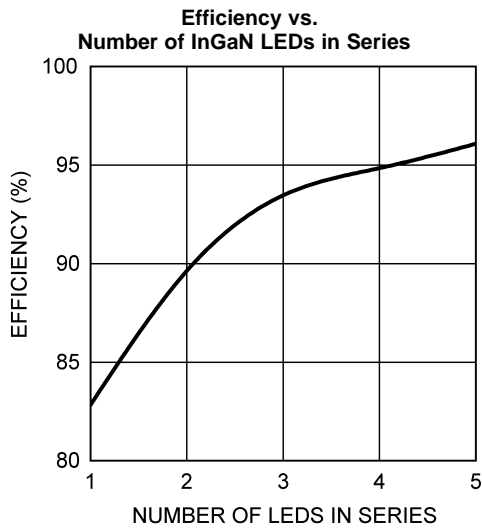

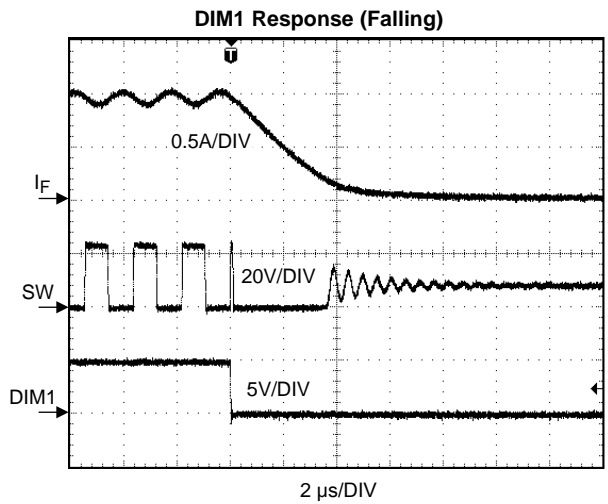
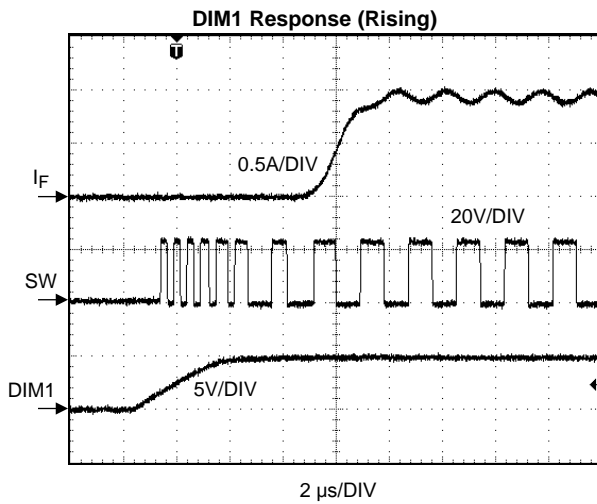
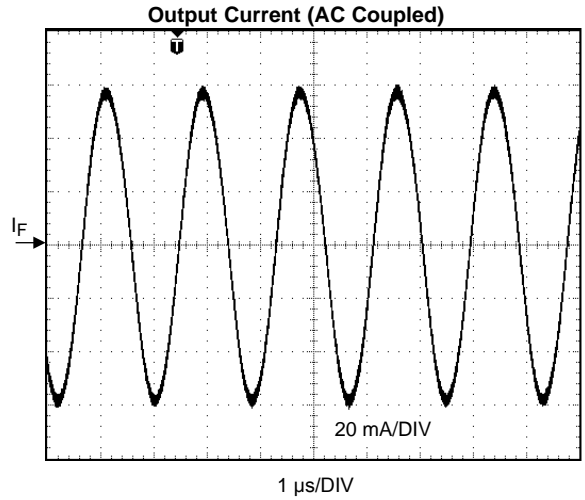
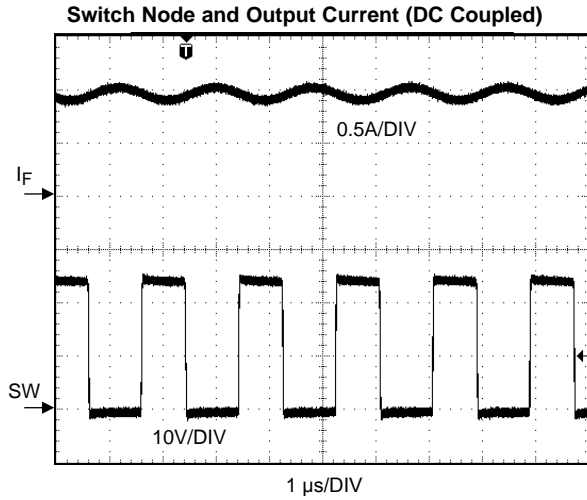
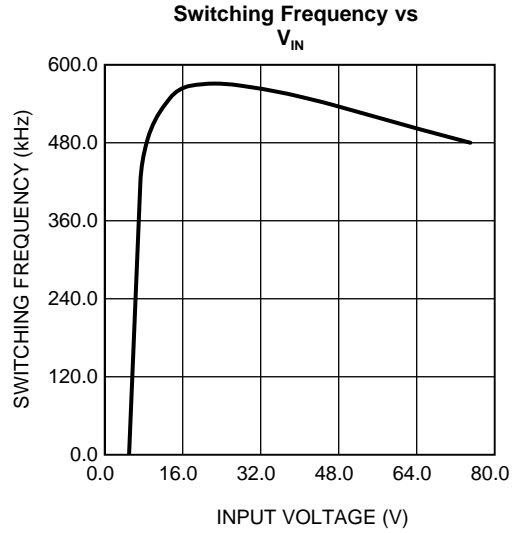
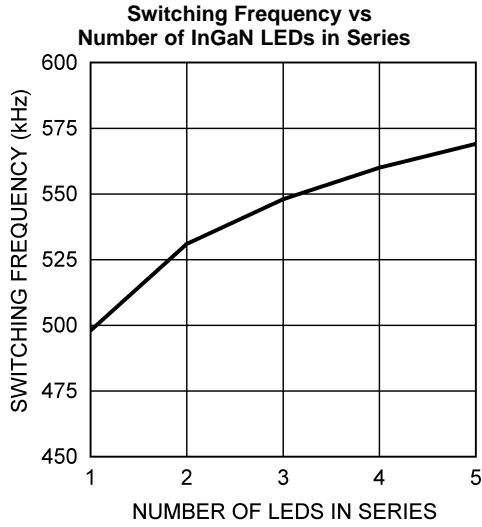

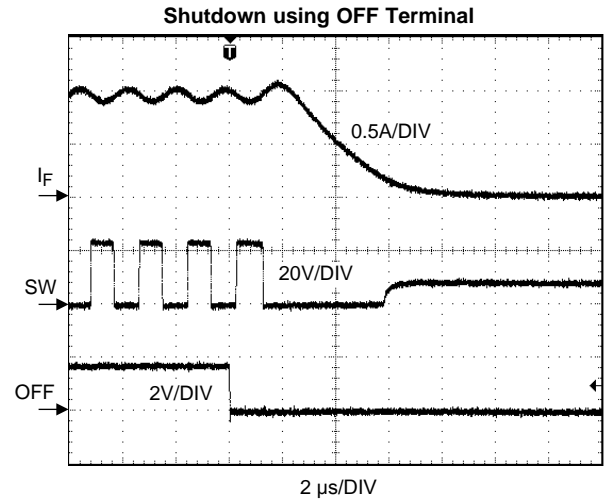
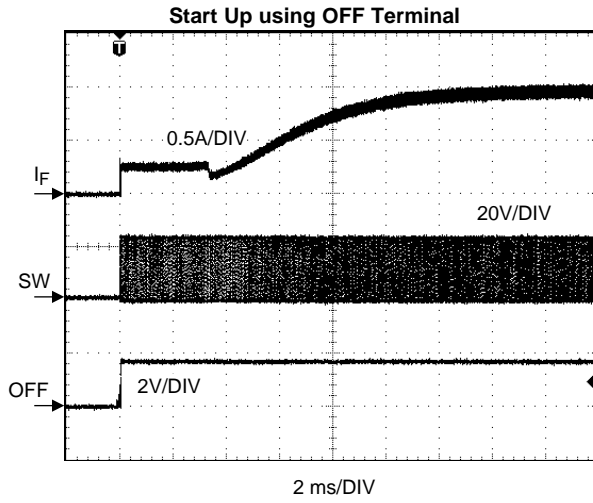

11 Layout

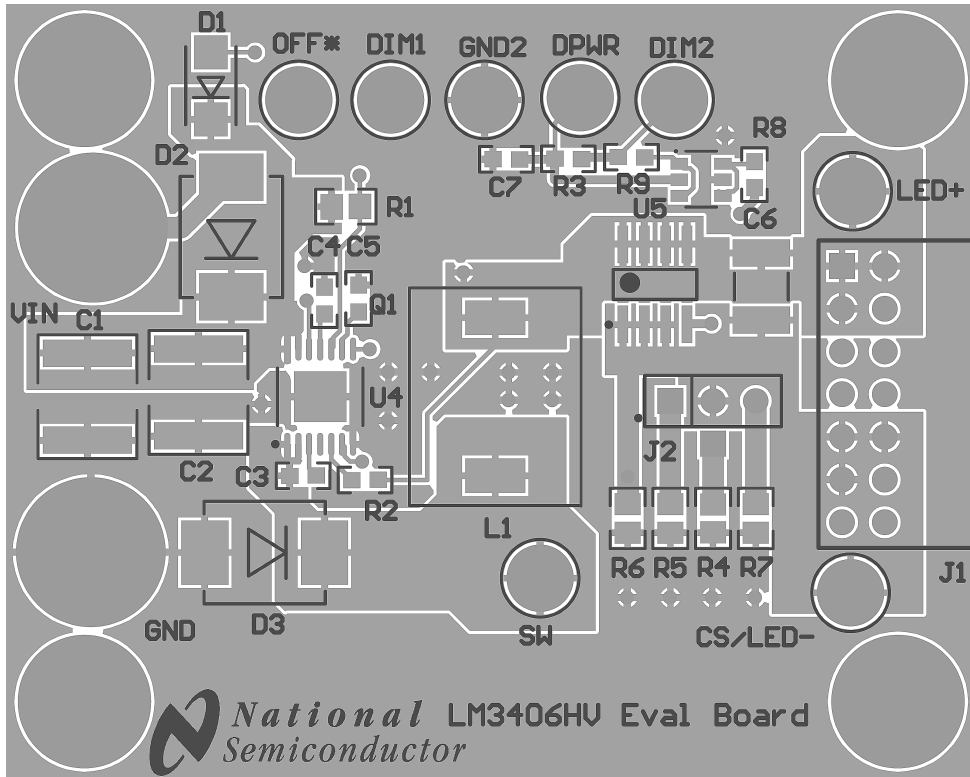

Figure 5. Top Layer and Top Overlay

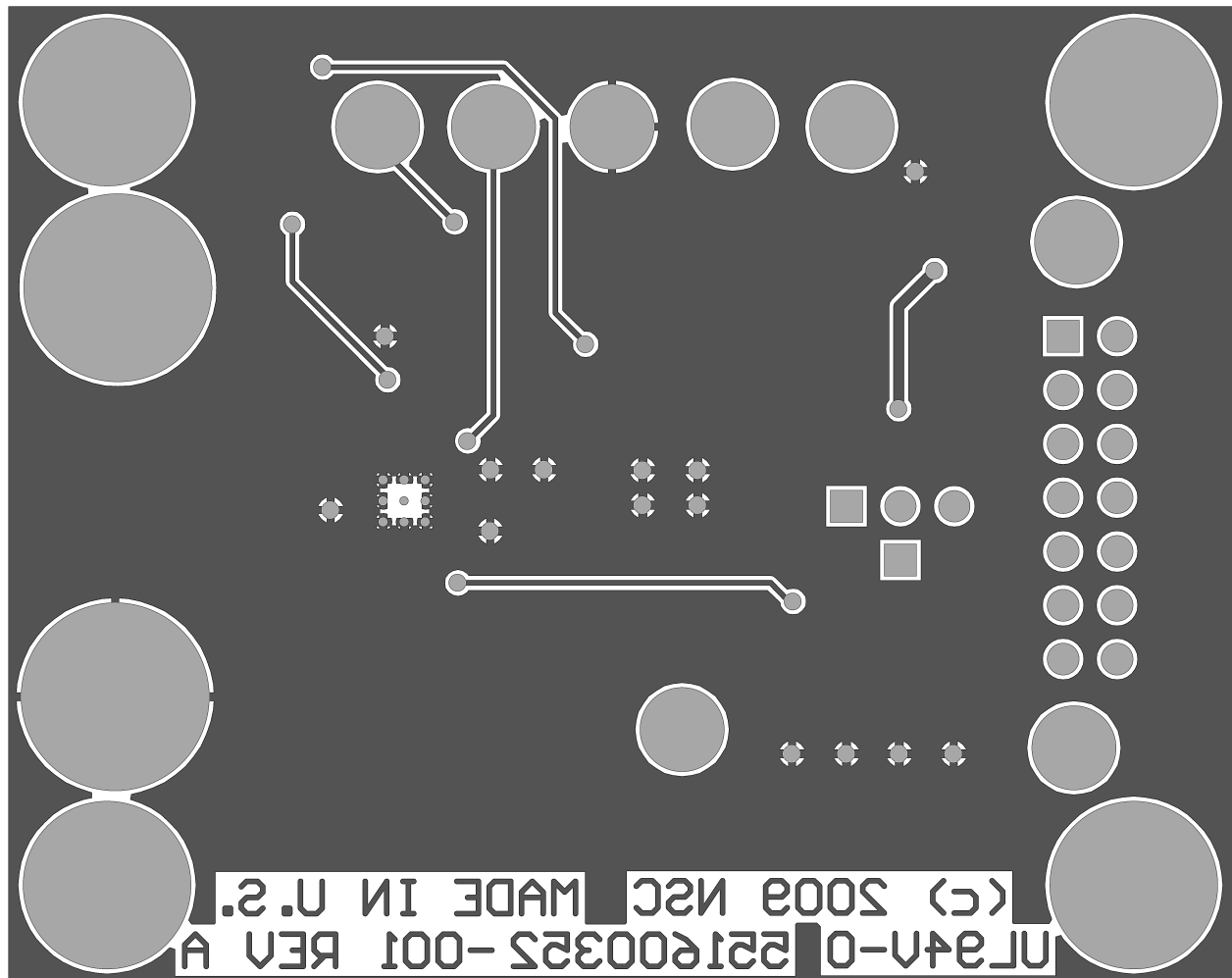

Figure 6. Bottom Layer and Bottom Overlay

## IMPORTANT NOTICE

Texas Instruments Incorporated and its subsidiaries (TI) reserve the right to make corrections, enhancements, improvements and other changes to its semiconductor products and services per JESD46, latest issue, and to discontinue any product or service per JESD48, latest issue. Buyers should obtain the latest relevant information before placing orders and should verify that such information is current and complete. All semiconductor products (also referred to herein as "components") are sold subject to TI's terms and conditions of sale supplied at the time of order acknowledgment.

TI warrants performance of its components to the specifications applicable at the time of sale, in accordance with the warranty in TI's terms and conditions of sale of semiconductor products. Testing and other quality control techniques are used to the extent TI deems necessary to support this warranty. Except where mandated by applicable law, testing of all parameters of each component is not necessarily performed.

TI assumes no liability for applications assistance or the design of Buyers' products. Buyers are responsible for their products and applications using TI components. To minimize the risks associated with Buyers' products and applications, Buyers should provide adequate design and operating safeguards.

TI does not warrant or represent that any license, either express or implied, is granted under any patent right, copyright, mask work right, or other intellectual property right relating to any combination, machine, or process in which TI components or services are used. Information published by TI regarding third-party products or services does not constitute a license to use such products or services or a warranty or endorsement thereof. Use of such information may require a license from a third party under the patents or other intellectual property of the third party, or a license from TI under the patents or other intellectual property of TI.

Reproduction of significant portions of TI information in TI data books or data sheets is permissible only if reproduction is without alteration and is accompanied by all associated warranties, conditions, limitations, and notices. TI is not responsible or liable for such altered documentation. Information of third parties may be subject to additional restrictions.

Resale of TI components or services with statements different from or beyond the parameters stated by TI for that component or service voids all express and any implied warranties for the associated TI component or service and is an unfair and deceptive business practice. TI is not responsible or liable for any such statements.

Buyer acknowledges and agrees that it is solely responsible for compliance with all legal, regulatory and safety-related requirements concerning its products, and any use of TI components in its applications, notwithstanding any applications-related information or support that may be provided by TI. Buyer represents and agrees that it has all the necessary expertise to create and implement safeguards which anticipate dangerous consequences of failures, monitor failures and their consequences, lessen the likelihood of failures that might cause harm and take appropriate remedial actions. Buyer will fully indemnify TI and its representatives against any damages arising out of the use of any TI components in safety-critical applications.

In some cases, TI components may be promoted specifically to facilitate safety-related applications. With such components, TI's goal is to help enable customers to design and create their own end-product solutions that meet applicable functional safety standards and requirements. Nonetheless, such components are subject to these terms.

No TI components are authorized for use in FDA Class III (or similar life-critical medical equipment) unless authorized officers of the parties have executed a special agreement specifically governing such use.

Only those TI components which TI has specifically designated as military grade or "enhanced plastic" are designed and intended for use in military/aerospace applications or environments. Buyer acknowledges and agrees that any military or aerospace use of TI components which have **not** been so designated is solely at the Buyer's risk, and that Buyer is solely responsible for compliance with all legal and regulatory requirements in connection with such use.

TI has specifically designated certain components as meeting ISO/TS16949 requirements, mainly for automotive use. In any case of use of non-designated products, TI will not be responsible for any failure to meet ISO/TS16949.

### Products

Audio	<a href="http://www.ti.com/audio">www.ti.com/audio</a>
Amplifiers	<a href="http://amplifier.ti.com">amplifier.ti.com</a>
Data Converters	<a href="http://dataconverter.ti.com">dataconverter.ti.com</a>
DLP® Products	<a href="http://www.dlp.com">www.dlp.com</a>
DSP	<a href="http://dsp.ti.com">dsp.ti.com</a>
Clocks and Timers	<a href="http://www.ti.com/clocks">www.ti.com/clocks</a>
Interface	<a href="http://interface.ti.com">interface.ti.com</a>
Logic	<a href="http://logic.ti.com">logic.ti.com</a>
Power Mgmt	<a href="http://power.ti.com">power.ti.com</a>
Microcontrollers	<a href="http://microcontroller.ti.com">microcontroller.ti.com</a>
RFID	<a href="http://www.ti-rfid.com">www.ti-rfid.com</a>
OMAP Applications Processors	<a href="http://www.ti.com/omap">www.ti.com/omap</a>
Wireless Connectivity	<a href="http://www.ti.com/wirelessconnectivity">www.ti.com/wirelessconnectivity</a>

### Applications

Automotive and Transportation	<a href="http://www.ti.com/automotive">www.ti.com/automotive</a>
Communications and Telecom	<a href="http://www.ti.com/communications">www.ti.com/communications</a>
Computers and Peripherals	<a href="http://www.ti.com/computers">www.ti.com/computers</a>
Consumer Electronics	<a href="http://www.ti.com/consumer-apps">www.ti.com/consumer-apps</a>
Energy and Lighting	<a href="http://www.ti.com/energy">www.ti.com/energy</a>
Industrial	<a href="http://www.ti.com/industrial">www.ti.com/industrial</a>
Medical	<a href="http://www.ti.com/medical">www.ti.com/medical</a>
Security	<a href="http://www.ti.com/security">www.ti.com/security</a>
Space, Avionics and Defense	<a href="http://www.ti.com/space-avionics-defense">www.ti.com/space-avionics-defense</a>
Video and Imaging	<a href="http://www.ti.com/video">www.ti.com/video</a>

### TI E2E Community

[e2e.ti.com](http://e2e.ti.com)

## Looking for pricing, stock, or lifecycle information?

Click below to explore more details on WIN SOURCE:

 [View LM3406HVEVAL/NOPB on WIN SOURCE](#)

 [Texas Instruments](#) Information

## Optimize Your Supply Chain with WIN SOURCE Solutions

-  Global Sourcing Solution
-  Obsolete Management
-  Cost Control Management
-  Shortage Management
-  Alternative Solution
-  Excess Inventory Management