



**THE DATASHEET OF  
CCZACC06A1RTCR**



## Z-Accel 2.4 GHz ZigBee® Processor

*Accelerate your ZigBee Development*

### Applications

- ZigBee™ systems
- Home/Building automation
- Industrial control and monitoring

- Low power wireless sensor networks
- Set-top boxes and remote controls
- Automated Meter Reading

### Description

The **CCZACC06** is a cost-effective, low power, Z-Accel ZigBee Processor that provides full ZigBee functionality with a minimal development effort.

Z-Accel is a solution where TI's ZigBee stack, Z-Stack, runs on a ZigBee Processor and the application runs on an external microcontroller. The **CCZACC06** handles all the timing critical and processing intensive ZigBee protocol tasks, and leaves the resources of the application microcontroller free to handle the application.

Z-Accel makes it easy to add ZigBee to new or existing products at the same time as it provides great flexibility in choice of microcontroller.

**CCZACC06** interfaces any microcontroller through an SPI or UART interface. There is no need to learn a new microcontroller or new

tools. **CCZACC06** can for example be combined with an MSP430.

**CCZACC06** supports TI's SimpleAPI. SimpleAPI has only 10 API calls to learn, which drastically simplifies the development of ZigBee applications.

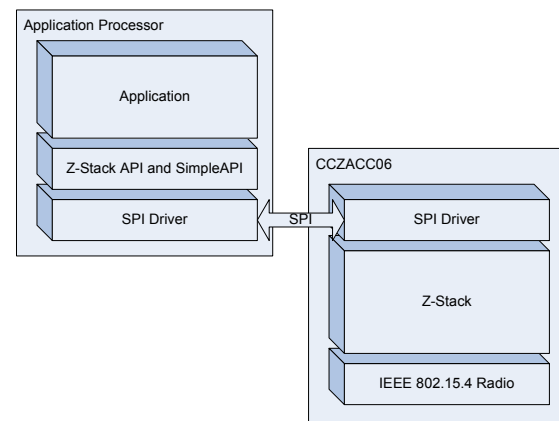

### Key Features

- Simple integration of ZigBee into any design
- Running the mature and stable ZigBee 2006 compliant TI Z-Stack
- SPI or UART interface to any microcontroller running the application
- Simple API and full ZigBee API supported
- Can implement any type of ZigBee device: Coordinator, Router or End Device
- Automatically enters low power mode (<0.5 uA) in idle periods when configured as End Device
- Radio
  - Fully integrated and robust IEEE 802.15.4-compliant 2.4 GHz DSSS RF transceiver
  - Excellent receiver sensitivity and best in class robustness to interferers
- Power Supply
  - Wide supply voltage range (2.0V – 3.6V)
  - Low current consumption (RX: 27 mA, TX: 27 mA) and fast transition times.
- External System
  - Very few external components
  - RoHS compliant 7x7mm QLP48 package
- Peripherals and Supporting Functions
  - Port expander with 4 general I/O pins, two with increased sink/source capability
  - Battery monitor and temperature sensor
  - 7-12 bits ADC with two channels
  - Robust power-on-reset and brown-out-reset circuitry
- Tools and Development
  - Packet sniffer PC software
  - Reference designs

## Table Of Contents

|   |           |
|---|-----------|
| <b>APPLICATIONS</b> .....                                     | <b>1</b>  |
| <b>DESCRIPTION</b> .....                                      | <b>1</b>  |
| <b>KEY FEATURES</b> .....                                     | <b>1</b>  |
| <b>TABLE OF CONTENTS</b> .....                                | <b>2</b>  |
| <b>1 ABBREVIATIONS</b> .....                                  | <b>4</b>  |
| <b>2 REFERENCES</b> .....                                     | <b>5</b>  |
| <b>3 ABSOLUTE MAXIMUM RATINGS</b> .....                       | <b>6</b>  |
| <b>4 OPERATING CONDITIONS</b> .....                           | <b>6</b>  |
| <b>5 ELECTRICAL SPECIFICATIONS</b> .....                      | <b>7</b>  |
| 5.1 GENERAL CHARACTERISTICS .....                             | 8         |
| 5.2 RF RECEIVE SECTION .....                                  | 9         |
| 5.3 RF TRANSMIT SECTION.....                                  | 9         |
| 5.4 32 MHz CRYSTAL OSCILLATOR.....                            | 10        |
| 5.5 32.768 kHz CRYSTAL OSCILLATOR .....                       | 10        |
| 5.6 32 kHz RC OSCILLATOR.....                                 | 11        |
| 5.7 16 MHz RC OSCILLATOR .....                                | 11        |
| 5.8 FREQUENCY SYNTHESIZER CHARACTERISTICS .....               | 12        |
| 5.9 ANALOG TEMPERATURE SENSOR .....                           | 12        |
| 5.10 ADC .....  | 12        |
| 5.11 CONTROL AC CHARACTERISTICS.....                          | 14        |
| 5.12 SPI AC CHARACTERISTICS .....                             | 15        |
| 5.13 PORT OUTPUTS AC CHARACTERISTICS .....                    | 15        |
| 5.14 DC CHARACTERISTICS .....                                 | 15        |
| <b>6 PIN AND I/O PORT CONFIGURATION</b> .....                 | <b>17</b> |
| <b>7 CIRCUIT DESCRIPTION</b> .....                            | <b>19</b> |
| <b>8 APPLICATION CIRCUIT</b> .....                            | <b>20</b> |
| 8.1 INPUT / OUTPUT MATCHING .....                             | 20        |
| 8.2 BIAS RESISTORS .....                                      | 20        |
| 8.3 CRYSTAL.....  | 20        |
| 8.4 VOLTAGE REGULATORS .....                                  | 20        |
| 8.5 POWER SUPPLY DECOUPLING AND FILTERING.....                | 21        |
| <b>9 PERIPHERALS</b> .....                                    | <b>23</b> |
| 9.1 RESET .....   | 23        |
| 9.2 I/O PORTS.....  | 23        |
| 9.3 ADC .....   | 25        |
| 9.4 RANDOM NUMBER GENERATOR .....                             | 27        |
| 9.5 USART.....  | 28        |
| <b>10 RADIO</b> .....   | <b>29</b> |
| 10.1 IEEE 802.15.4 MODULATION FORMAT .....                    | 30        |
| 10.2 DEMODULATOR, SYMBOL SYNCHRONIZER AND DATA DECISION ..... | 31        |
| 10.3 FRAME FORMAT .....                                       | 31        |
| 10.4 SYNCHRONIZATION HEADER .....                             | 32        |
| 10.5 MAC PROTOCOL DATA UNIT .....                             | 32        |
| 10.6 FRAME CHECK SEQUENCE .....                               | 32        |
| 10.7 LINEAR IF AND AGC SETTINGS .....                         | 33        |
| 10.8 CLEAR CHANNEL ASSESSMENT.....                            | 33        |
| 10.9 VCO AND PLL SELF-CALIBRATION.....                        | 33        |
| 10.10 INPUT / OUTPUT MATCHING.....                            | 33        |
| 10.11 SYSTEM CONSIDERATIONS AND GUIDELINES .....              | 34        |
| 10.12 PCB LAYOUT RECOMMENDATION .....                         | 35        |
| 10.13 ANTENNA CONSIDERATIONS .....                            | 35        |

|           |  |           |
|-----------|--|-----------|
| <b>11</b> | <b>VOLTAGE REGULATORS</b> .....                  | <b>36</b> |
| 11.1      | VOLTAGE REGULATORS POWER-ON.....                 | 36        |
| <b>12</b> | <b>PACKAGE DESCRIPTION (QLP 48)</b> .....        | <b>37</b> |
| 12.1      | RECOMMENDED PCB LAYOUT FOR PACKAGE (QLP 48)..... | 38        |
| 12.2      | PACKAGE THERMAL PROPERTIES.....                  | 38        |
| 12.3      | SOLDERING INFORMATION .....                      | 38        |
| 12.4      | TRAY SPECIFICATION .....                         | 38        |
| 12.5      | CARRIER TAPE AND REEL SPECIFICATION .....        | 38        |
| <b>13</b> | <b>ORDERING INFORMATION</b> .....                | <b>40</b> |
| <b>14</b> | <b>GENERAL INFORMATION</b> .....                 | <b>41</b> |
| 14.1      | DOCUMENT HISTORY .....                           | 41        |
| <b>15</b> | <b>ADDRESS INFORMATION</b> .....                 | <b>41</b> |
| <b>16</b> | <b>TI WORLDWIDE TECHNICAL SUPPORT</b> .....      | <b>41</b> |

## 1 Abbreviations

|         |  |         |   |
|---------|--|---------|---|
| ADC     | Analog to Digital Converter                            | LSB     | Least Significant Byte                                  |
| AES     | Advanced Encryption Standard                           | MAC     | Medium Access Control                                   |
| AGC     | Automatic Gain Control                                 | MISO    | Master In Slave Out                                     |
| API     | Application Programming Interface                      | MOSI    | Master Out Slave In                                     |
| ARIB    | Association of Radio Industries and Businesses         | MPDU    | MAC Protocol Data Unit                                  |
| BOD     | Brown Out Detector                                     | MSB     | Most Significant Byte                                   |
| BOM     | Bill of Materials                                      | MUX     | Multiplexer   |
| CCA     | Clear Channel Assessment                               | NA      | Not Available   |
| CFR     | Code of Federal Regulations                            | NC      | Not Connected   |
| CPU     | Central Processing Unit                                | O-QPSK  | Offset - Quadrature Phase Shift Keying                  |
| CRC     | Cyclic Redundancy Check                                | PA      | Power Amplifier   |
| CSMA-CA | Carrier Sense Multiple Access with Collision Avoidance | PCB     | Printed Circuit Board                                   |
| CW      | Continuous Wave  | PER     | Packet Error Rate                                       |
| DAC     | Digital to Analog Converter                            | PHY     | Physical Layer  |
| DC      | Direct Current   | PLL     | Phase Locked Loop                                       |
| DNL     | Differential Nonlinearity                              | PM{0-3} | Power Mode 0-3  |
| DSM     | Delta Sigma Modulator                                  | POR     | Power On Reset  |
| DSSS    | Direct Sequence Spread Spectrum                        | PWM     | Pulse Width Modulator                                   |
| EM      | Evaluation Module                                      | QLP     | Quad Leadless Package                                   |
| ENOB    | Effective Number of bits                               | RAM     | Random Access Memory                                    |
| ESD     | Electro Static Discharge                               | RC      | Resistor-Capacitor                                      |
| ESR     | Equivalent Series Resistance                           | RCOSC   | RC Oscillator   |
| ETSI    | European Telecommunications Standards Institute        | RF      | Radio Frequency   |
| EVM     | Error Vector Magnitude                                 | RoHS    | Restriction on Hazardous Substances                     |
| FCC     | Federal Communications Commission                      | RSSI    | Receive Signal Strength Indicator                       |
| FCF     | Frame Control Field                                    | RX      | Receive   |
| FCS     | Frame Check Sequence                                   | SCK     | Serial Clock  |
| I/O     | Input / Output   | SFD     | Start of Frame Delimiter                                |
| I/Q     | In-phase / Quadrature-phase                            | SHR     | Synchronization Header                                  |
| IEEE    | Institute of Electrical and Electronics Engineers      | SINAD   | Signal-to-noise and distortion ratio                    |
| IF      | Intermediate Frequency                                 | SPI     | Serial Peripheral Interface                             |
| INL     | Integral Nonlinearity                                  | SRAM    | Static Random Access Memory                             |
| ISM     | Industrial, Scientific and Medical                     | ST      | Sleep Timer   |
| JEDEC   | Joint Electron Device Engineering Council              | T/R     | Tape and reel   |
| KB      | 1024 bytes   | T/R     | Transmit / Receive                                      |
| kbps    | kilo bits per second                                   | TBD     | To Be Decided / To Be Defined                           |
| LFSR    | Linear Feedback Shift Register                         | THD     | Total Harmonic Distortion                               |
| LNA     | Low-Noise Amplifier                                    | TI      | Texas Instruments                                       |
| LO      | Local Oscillator                                       | TX      | Transmit  |
| LQI     | Link Quality Indication                                | UART    | Universal Asynchronous Receiver/Transmitter             |
| LSB     | Least Significant Bit / Byte                           | USART   | Universal Synchronous/Asynchronous Receiver/Transmitter |
|         |  | VGA     | Variable Gain Amplifier                                 |
|         |  | XOSC    | Crystal Oscillator                                      |

## 2 References

- [1] IEEE std. 802.15.4 - 2006: Wireless Medium Access Control (MAC) and Physical Layer (PHY) specifications for Low Rate Wireless Personal Area Networks (LR-WPANs).  
<http://standards.ieee.org/getieee802/download/802.15.4-2006.pdf>
- [2] CCZACC06 Interface Specification  
<http://www.ti.com/lit/pdf/swra175>

### 3 Absolute Maximum Ratings

Under no circumstances must the absolute maximum ratings given in Table 1 be violated. Stress exceeding one or more of the limiting values may cause permanent damage to the device.

**Table 1: Absolute Maximum Ratings**

| Parameter   | Min  | Max                 | Units | Condition   |
|---|------|---------------------|-------|---|
| Supply voltage, VDD                                 | -0.3 | 3.9                 | V     | All supply pins must have the same voltage  |
| Voltage on any digital pin                          | -0.3 | VDD+0.3,<br>max 3.9 | V     |   |
| Voltage on the 1.8V pins (pin no. 22, 25-40 and 42) | -0.3 | 2.0                 | V     |   |
| Input RF level                                      |      | 10                  | dBm   |   |
| Storage temperature range                           | -50  | 150                 | °C    | Device not programmed   |
| Reflow soldering temperature                        |      | 260                 | °C    | According to IPC/JEDEC J-STD-020C   |
| ESD   |      | <500                | V     | On RF pads (RF_P, RF_N, AVDD_RF1, and AVDD_RF2), according to Human Body Model, JEDEC STD 22, method A114 |
|   |      | 700                 | V     | All other pads, according to Human Body Model, JEDEC STD 22, method A114                                  |
|   |      | 200                 | V     | According to Charged Device Model, JEDEC STD 22, method C101  |



**Caution!** ESD sensitive device. Precaution should be used when handling the device in order to prevent permanent damage.

### 4 Operating Conditions

The operating conditions for *CCZACC06* are listed in Table 2.

**Table 2: Operating Conditions**

| Parameter   | Min | Max | Unit | Condition   |
|---|-----|-----|------|---|
| Operating ambient temperature range, T <sub>A</sub> | -40 | 85  | °C   |   |
| Operating supply voltage                            | 2.0 | 3.6 | V    | The supply pins to the radio part must be driven by the 1.8 V on-chip regulator |

## 5 Electrical Specifications

Measured on Texas Instruments *CCZACC06* EM reference design with  $T_A=25^{\circ}\text{C}$  and  $V_{DD}=3.0\text{V}$  unless stated otherwise.

**Table 3: Electrical Specifications**

| Parameter                                    | Min | Typ  | Max | Unit          | Condition  |
|--|-----|------|-----|---------------|--|
| <b>Current Consumption</b>                   |     |      |     |               |  |
| CPU Active Mode, 16 MHz, low CPU activity    |     | 4.3  |     | mA            | Digital regulator on. 16 MHz RCOSC running. No radio, crystals, or peripherals active.<br>Low CPU activity: no flash access (i.e. only cache hit), no RAM access.          |
| CPU Active Mode, 16 MHz, medium CPU activity |     | 5.1  |     | mA            | Digital regulator on. 16 MHz RCOSC running. No radio, crystals, or peripherals active.<br>Medium CPU activity: normal flash access <sup>1</sup> , minor RAM access.        |
| CPU Active Mode, 16 MHz, high CPU activity   |     | 5.7  |     | mA            | Digital regulator on. 16 MHz RCOSC running. No radio, crystals, or peripherals active.<br>High CPU activity: normal flash access, extensive RAM access and heavy CPU load. |
| CPU Active Mode, 32 MHz, low CPU activity    |     | 9.5  |     | mA            | 32 MHz XOSC running. No radio or peripherals active.<br>Low CPU activity : no flash access (i.e. only cache hit), no RAM access  |
| CPU Active Mode, 32 MHz, medium CPU activity |     | 10.5 |     | mA            | 32 MHz XOSC running. No radio or peripherals active.<br>Medium CPU activity: normal flash access, minor RAM access.  |
| CPU Active Mode, 32 MHz, high CPU activity   |     | 12.3 |     | mA            | 32 MHz XOSC running. No radio or peripherals active.<br>High CPU activity: normal flash access, extensive RAM access and heavy CPU load.                                   |
| CPU Active and RX Mode                       |     | 26.7 |     | mA            | CPU running at full speed (32MHz), 32MHz XOSC running, radio in RX mode, -50 dBm input power. No peripherals active. Low CPU activity.                                     |
| CPU Active and TX Mode, 0dBm                 |     | 26.9 |     | mA            | CPU running at full speed (32MHz), 32MHz XOSC running, radio in TX mode, 0dBm output power. No peripherals active. Low CPU activity.                                       |
| Power mode 1                                 |     | 190  |     | $\mu\text{A}$ | Digital regulator on, 16 MHz RCOSC and 32 MHz crystal oscillator off. 32.768 kHz XOSC, POR and ST active. RAM retention.   |
| Power mode 2                                 |     | 0.5  |     | $\mu\text{A}$ | Digital regulator off, 16 MHz RCOSC and 32 MHz crystal oscillator off. 32.768 kHz XOSC, POR and ST active. RAM retention.  |
| Power mode 3                                 |     | 0.3  |     | $\mu\text{A}$ | No clocks. RAM retention. POR active.  |
| <b>Peripheral Current Consumption</b>        |     |      |     |               |  |
| Sleep Timer                                  |     | 0.2  |     | $\mu\text{A}$ | Including 32.753 kHz RCOSC.  |
| ADC  |     | 1.2  |     | mA            | When converting.   |
| Flash write                                  |     | 3    |     | mA            | Estimated value  |
| Flash erase                                  |     | 3    |     | mA            | Estimated value  |

<sup>1</sup> Normal Flash access means that the code used exceeds the cache storage so cache misses will happen frequently.

## 5.1 General Characteristics

Measured on Texas Instruments *CCZACC06* EM reference design with  $T_A=25^\circ\text{C}$  and  $V_{DD}=3.0\text{V}$  unless stated otherwise.

**Table 4: General Characteristics**

| Parameter   | Min  | Typ | Max    | Unit    | Condition/Note  |
|---|------|-----|--------|---------|---|
| <b>Wake-Up and Timing</b>   |      |     |        |         |   |
| Power mode 1 → power mode 0   |      | 4.1 |        | μs      | Digital regulator on, 16 MHz RCOSC and 32 MHz crystal oscillator off. Start-up of 16 MHz RCOSC.   |
| Power mode 2 or 3 → power mode 0  |      | 120 |        | μs      | Digital regulator off, 16 MHz RCOSC and 32 MHz crystal oscillator off. Start-up of regulator and 16 MHz RCOSC.  |
| Active → TX or RX<br>32MHz XOSC initially OFF.<br>Voltage regulator initially OFF |      | 525 |        | μs      | Time from enabling radio part in power mode 0, until TX or RX starts. Includes start-up of voltage regulator and crystal oscillator in parallel. Crystal ESR=16Ω. |
| Active → TX or RX<br>Voltage regulator initially OFF                              |      | 320 |        | μs      | Time from enabling radio part in power mode 0, until TX or RX starts. Includes start-up of voltage regulator.   |
| Active → RX or TX   |      |     | 192    | μs      | Radio part already enabled.<br>Time until RX or TX starts.  |
| RX/TX turnaround  |      |     | 192    | μs      |   |
| <b>Radio part</b>   |      |     |        |         |   |
| RF Frequency Range  | 2400 |     | 2483.5 | MHz     | Programmable in 1 MHz steps, 5 MHz between channels for compliance with [1]   |
| Radio bit rate  |      | 250 |        | kbps    | As defined by [1]   |
| Radio chip rate   |      | 2.0 |        | MChip/s | As defined by [1]   |

## 5.2 RF Receive Section

Measured on Texas Instruments *CCZACC06* EM reference design with  $T_A=25^\circ\text{C}$  and  $V_{DD}=3.0\text{V}$  unless stated otherwise.

**Table 5: RF Receive Parameters**

| Parameter  | Min | Typ  | Max        | Unit   | Condition/Note   |
|--|-----|--|------------|--|--|
| Receiver sensitivity   |     | -92  |            | dBm  | PER = 1%, as specified by [1]<br>Measured in 50 $\Omega$ single endedly through a balun.<br>[1] requires -85 dBm   |
| Saturation (maximum input level)   |     | 10   |            | dBm  | PER = 1%, as specified by [1]<br>Measured in 50 $\Omega$ single endedly through a balun.<br>[1] requires -20 dBm   |
| Adjacent channel rejection<br>+ 5 MHz channel spacing  |     | 41   |            | dB   | Wanted signal -88dBm, adjacent modulated channel at +5 MHz, PER = 1 %, as specified by [1].<br>[1] requires 0 dB   |
| Adjacent channel rejection<br>- 5 MHz channel spacing  |     | 30   |            | dB   | Wanted signal -88dBm, adjacent modulated channel at -5 MHz, PER = 1 %, as specified by [1].<br>[1] requires 0 dB   |
| Alternate channel rejection<br>+ 10 MHz channel spacing  |     | 55   |            | dB   | Wanted signal -88dBm, adjacent modulated channel at +10 MHz, PER = 1 %, as specified by [1]<br>[1] requires 30 dB  |
| Alternate channel rejection<br>- 10 MHz channel spacing  |     | 53   |            | dB   | Wanted signal -88dBm, adjacent modulated channel at -10 MHz, PER = 1 %, as specified by [1]<br>[1] requires 30 dB  |
| Channel rejection<br>$\geq + 15$ MHz<br>$\leq - 15$ MHz  |     | 55<br>53   |            | dB<br>dB   | Wanted signal @ -82 dBm. Undesired signal is an 802.15.4 modulated channel, stepped through all channels from 2405 to 2480 MHz. Signal level for PER = 1%. Values are estimated. |
| Co-channel rejection   |     | -6   |            | dB   | Wanted signal @ -82 dBm. Undesired signal is 802.15.4 modulated at the same frequency as the desired signal. Signal level for PER = 1%.  |
| Blocking / Desensitization<br>+ 5 MHz from band edge<br>+ 10 MHz from band edge<br>+ 20 MHz from band edge<br>+ 50 MHz from band edge<br>- 5 MHz from band edge<br>- 10 MHz from band edge<br>- 20 MHz from band edge<br>- 50 MHz from band edge |     | -42<br>-29<br>-26<br>-22<br>-31<br>-36<br>-24<br>-25 |            | dBm<br>dBm<br>dBm<br>dBm<br>dBm<br>dBm<br>dBm<br>dBm | Wanted signal 3 dB above the sensitivity level, CW jammer, PER = 1%. Measured according to EN 300 440 class 2.   |
| Spurious emission<br>30 – 1000 MHz<br>1 – 12.75 GHz  |     |  | -64<br>-75 | dBm<br>dBm   | Conducted measurement in a 50 $\Omega$ single ended load. Complies with EN 300 328, EN 300 440 class 2, FCC CFR47, Part 15 and ARIB STD-T-66.                                    |
| Frequency error tolerance  |     | $\pm 140$  |            | ppm  | Difference between centre frequency of the received RF signal and local oscillator frequency.<br>[1] requires minimum 80 ppm   |
| Symbol rate error tolerance  |     | $\pm 900$  |            | ppm  | Difference between incoming symbol rate and the internally generated symbol rate<br>[1] requires minimum 80 ppm  |

## 5.3 RF Transmit Section

Measured on Texas Instruments *CCZACC06* EM reference design with  $T_A=25^\circ\text{C}$ ,  $V_{DD}=3.0\text{V}$ , and nominal output power unless stated otherwise.

**Table 6: RF Transmit Parameters**

| Parameter   | Min | Typ                              | Max | Unit                     | Condition/Note   |
|---|-----|----------------------------------|-----|--------------------------|--|
| Nominal output power  |     | 0                                |     | dBm                      | Delivered to a single ended 50 Ω load through a balun.<br>[1] requires minimum -3 dBm  |
| Harmonics<br>2 <sup>nd</sup> harmonic<br>3 <sup>rd</sup> harmonic<br>4 <sup>th</sup> harmonic<br>5 <sup>th</sup> harmonic |     | -50.7<br>-55.8<br>-54.2<br>-53.4 |     | dBm<br>dBm<br>dBm<br>dBm | Measurement conducted with 100 kHz resolution bandwidth on spectrum analyzer. Output Delivered to a single ended 50 Ω load through a balun.  |
| Spurious emission<br>30 - 1000 MHz<br>1- 12.75 GHz<br>1.8 - 1.9 GHz<br>5.15 - 5.3 GHz                                     |     | -47<br>-43<br>-58<br>-56         |     | dBm<br>dBm<br>dBm<br>dBm | Maximum output power.<br>Texas Instruments <i>CCZACC06</i> EM reference design complies with EN 300 328, EN 300 440, FCC CFR47 Part 15 and ARIB STD-T-66.<br>Transmit on 2480MHz under FCC is supported by duty-cycling<br>The peak conducted spurious emission is -47 dBm @ 192 MHz which is in an EN 300 440 restricted band limited to -54 dBm. All radiated spurious emissions are within the limits of ETSI/FCC/ARIB. Conducted spurious emission (CSE) can be reduced with a simple band pass filter connected between matching network and RF connector (1.8 pF in parallel with 1.6 nH reduces the CSE by 20 dB), this filter must be connected to good RF ground. |
| EVM   |     | 11                               |     | %                        | Measured as defined by [1]<br>[1] requires max. 35 %   |
| Optimum load impedance  |     | 60<br>+ j164                     |     | Ω                        | Differential impedance as seen from the RF-port (RF_P and RF_N) towards the antenna <sup>2</sup> .   |

#### 5.4 32 MHz Crystal Oscillator

Measured on Texas Instruments *CCZACC06* EM reference design with T<sub>A</sub>=25°C and VDD=3.0V unless stated otherwise.

**Table 7: 32 MHz Crystal Oscillator Parameters**

| Parameter                              | Min  | Typ | Max | Unit | Condition/Note  |
|--|------|-----|-----|------|---|
| Crystal frequency                      |      | 32  |     | MHz  |   |
| Crystal frequency accuracy requirement | - 40 |     | 40  | ppm  | Including aging and temperature dependency, as specified by [1] |
| ESR                                    | 6    | 16  | 60  | Ω    | Simulated over operating conditions                             |
| C <sub>0</sub>                         | 1    | 1.9 | 7   | pF   | Simulated over operating conditions                             |
| C <sub>L</sub>                         | 10   | 13  | 16  | pF   | Simulated over operating conditions                             |
| Start-up time                          |      | 212 |     | μs   |   |

#### 5.5 32.768 kHz Crystal Oscillator

Measured on Texas Instruments *CCZACC06* EM reference design with T<sub>A</sub>=25°C and VDD=3.0V unless stated otherwise.

<sup>2</sup> This is for 2440MHz

**Table 8: 32.768 kHz Crystal Oscillator Parameters**

| Parameter                              | Min | Typ    | Max | Unit | Condition/Note  |
|--|-----|--------|-----|------|---|
| Crystal frequency                      |     | 32.768 |     | kHz  |   |
| Crystal frequency accuracy requirement | -40 |        | 40  | ppm  | Including aging and temperature dependency, as specified by [1] |
| ESR                                    |     | 40     | 130 | kΩ   | Simulated over operating conditions                             |
| C <sub>0</sub>                         |     | 0.9    | 2.0 | pF   | Simulated over operating conditions                             |
| C <sub>L</sub>                         |     | 12     | 16  | pF   | Simulated over operating conditions                             |
| Start-up time                          |     | 400    |     | ms   | Value is simulated.   |

## 5.6 32 kHz RC Oscillator

Measured on Texas Instruments *CCZACC06* EM reference design with T<sub>A</sub>=25°C and VDD=3.0V unless stated otherwise.

**Table 9: 32 kHz RC Oscillator parameters**

| Parameter                            | Min | Typ    | Max | Unit   | Condition/Note  |
|--------------------------------------|-----|--------|-----|--------|---|
| Calibrated frequency                 |     | 32.753 |     | kHz    | The calibrated 32 kHz RC Oscillator frequency is the 32 MHz XTAL frequency divided by 977   |
| Frequency accuracy after calibration |     | ±0.2   |     | %      | Value is estimated.   |
| Temperature coefficient              |     | +0.4   |     | % / °C | Frequency drift when temperature changes after calibration. Value is estimated.   |
| Supply voltage coefficient           |     | +3     |     | % / V  | Frequency drift when supply voltage changes after calibration. Value is estimated.  |
| Initial calibration time             |     | 1.7    |     | ms     | When the 32 kHz RC Oscillator is enabled, calibration is continuously done in the background as long as the 32 MHz crystal oscillator is running. |

## 5.7 16 MHz RC Oscillator

Measured on Texas Instruments *CCZACC06* EM reference design with T<sub>A</sub>=25°C and VDD=3.0V unless stated otherwise.

**Table 10: 16 MHz RC Oscillator parameters**

| Parameter                       | Min | Typ  | Max  | Unit     | Condition/Note  |
|---------------------------------|-----|------|------|----------|---|
| Frequency                       |     | 16   |      | MHz      | The calibrated 16 MHz RC Oscillator frequency is the 32 MHz XTAL frequency divided by 2                                   |
| Uncalibrated frequency accuracy |     | ±18  |      | %        |   |
| Calibrated frequency accuracy   |     | ±0.6 | ±1   | %        |   |
| Start-up time                   |     |      | 10   | μs       |   |
| Temperature coefficient         |     |      | -325 | ppm / °C | Frequency drift when temperature changes after calibration  |
| Supply voltage coefficient      |     |      | 28   | ppm / mV | Frequency drift when supply voltage changes after calibration   |
| Initial calibration time        |     | 50   |      | μs       | When the 16 MHz RC Oscillator is enabled it will be calibrated continuously when the 32MHz crystal oscillator is running. |

## 5.8 Frequency Synthesizer Characteristics

Measured on Texas Instruments *CCZACC06* EM reference design with  $T_A=25^\circ\text{C}$  and  $V_{DD}=3.0\text{V}$  unless stated otherwise.

**Table 11: Frequency Synthesizer Parameters**

| Parameter     | Min | Typ                  | Max | Unit                       | Condition/Note  |
|---------------|-----|----------------------|-----|----------------------------|---|
| Phase noise   |     | -116<br>-117<br>-118 |     | dBc/Hz<br>dBc/Hz<br>dBc/Hz | Unmodulated carrier<br>At $\pm 1.5$ MHz offset from carrier<br>At $\pm 3$ MHz offset from carrier<br>At $\pm 5$ MHz offset from carrier |
| PLL lock time |     |                      | 192 | $\mu\text{s}$              | The startup time until RX/TX turnaround. The crystal oscillator is running.   |

## 5.9 Analog Temperature Sensor

Measured on Texas Instruments *CCZACC06* EM reference design with  $T_A=25^\circ\text{C}$  and  $V_{DD}=3.0\text{V}$  unless stated otherwise.

**Table 12: Analog Temperature Sensor Parameters**

| Parameter                                   | Min | Typ   | Max | Unit                       | Condition/Note  |
|---|-----|-------|-----|----------------------------|---|
| Output voltage at $-40^\circ\text{C}$       |     | 0.648 |     | V                          | Value is estimated  |
| Output voltage at $0^\circ\text{C}$         |     | 0.743 |     | V                          | Value is estimated  |
| Output voltage at $+40^\circ\text{C}$       |     | 0.840 |     | V                          | Value is estimated  |
| Output voltage at $+80^\circ\text{C}$       |     | 0.939 |     | V                          | Value is estimated  |
| Temperature coefficient                     |     | 2.45  |     | $\text{mV}/^\circ\text{C}$ | Fitted from $-20^\circ\text{C}$ to $+80^\circ\text{C}$ on estimated values.   |
| Absolute error in calculated temperature    |     | -8    |     | $^\circ\text{C}$           | From $-20^\circ\text{C}$ to $+80^\circ\text{C}$ when assuming best fit for absolute accuracy on estimated values: $0.743\text{V}$ at $0^\circ\text{C}$ and $2.45\text{mV}/^\circ\text{C}$ .   |
| Error in calculated temperature, calibrated | -2  | 0     | 2   | $^\circ\text{C}$           | From $-20^\circ\text{C}$ to $+80^\circ\text{C}$ when using $2.45\text{mV}/^\circ\text{C}$ , after 1-point calibration at room temperature. Values are estimated. Indicated min/max with 1-point calibration is based on simulated values for typical process parameters |
| Current consumption increase when enabled   |     | 280   |     | $\mu\text{A}$              |   |

## 5.10 ADC

Measured with  $T_A=25^\circ\text{C}$  and  $V_{DD}=3.0\text{V}$ . Note that other data may result when using Texas Instruments' *CCZACC06* EM reference design.

**Table 13: ADC Characteristics**

| Parameter                      | Min | Typ  | Max | Unit             | Condition/Note                     |
|--------------------------------|-----|------|-----|------------------|------------------------------------|
| Input voltage                  | 0   |      | VDD | V                | VDD is voltage on AVDD_SOC pin     |
| Input resistance, signal       |     | 197  |     | $\text{k}\Omega$ | Simulated using 4 MHz clock speed. |
| Full-Scale Signal <sup>3</sup> |     | 2.97 |     | V                | Peak-to-peak, defines 0dBFS        |

<sup>3</sup> Measured with 300 Hz Sine input and VDD as reference.

| Parameter   | Min | Typ                          | Max | Unit                 | Condition/Note   |
|---|-----|------------------------------|-----|----------------------|--|
| ENOB<br>Single ended input  |     | 5.7<br>7.5<br>9.3<br>10.8    |     | bits                 | 7-bits setting.<br>9-bits setting.<br>10-bits setting.<br>12-bits setting. |
| ENOB <small>Error! Bookmark not defined.</small><br>Differential input              |     | 6.5<br>8.3<br>10.0<br>11.5   |     | bits                 | 7-bits setting.<br>9-bits setting.<br>10-bits setting.<br>12-bits setting. |
| Useful Power Bandwidth  |     | 0-20                         |     | kHz                  | 7-bits setting   |
| THD<br>-Single ended input<br>-Differential input                                   |     | -75.2<br>-86.6               |     | dB<br>dB             | 12-bits setting, -6dBFS<br>12-bits setting, -6dBFS                         |
| Signal To Non-Harmonic Ratio<br>-Single ended input<br>-Differential input          |     | 70.2<br>79.3                 |     | dB<br>dB             | 12-bits setting<br>12-bits setting   |
| Spurious Free Dynamic Range<br>-Single ended input<br>-Differential input           |     | 78.8<br>88.9                 |     | dB<br>dB             | 12-bits setting, -6dBFS<br>12-bits setting, -6dBFS                         |
| CMRR, differential input  |     | <-84                         |     | dB                   | 12-bit setting, 1 kHz Sine (0dBFS), limited by ADC resolution              |
| Crosstalk, single ended input   |     | <-84                         |     | dB                   | 12-bit setting, 1 kHz Sine (0dBFS), limited by ADC resolution              |
| Offset  |     | -3                           |     | mV                   | Mid. Scale   |
| Gain error  |     | 0.68                         |     | %                    |  |
| DNL   |     | 0.05<br>0.9                  |     | LSB<br>LSB           | 12-bits setting, mean<br>12-bits setting, max                              |
| INL   |     | 4.6<br>13.3                  |     | LSB<br>LSB           | 12-bits setting, mean<br>12-bits setting, max                              |
| SINAD<br>Single ended input<br>(-THD+N)   |     | 35.4<br>46.8<br>57.5<br>66.6 |     | dB<br>dB<br>dB<br>dB | 7-bits setting.<br>9-bits setting.<br>10-bits setting.<br>12-bits setting. |
| SINAD <small>Error! Bookmark not defined.</small><br>Differential input<br>(-THD+N) |     | 40.7<br>51.6<br>61.8<br>70.8 |     | dB<br>dB<br>dB<br>dB | 7-bits setting.<br>9-bits setting.<br>10-bits setting.<br>12-bits setting. |
| Conversion time   |     | 20<br>36<br>68<br>132        |     | μs<br>μs<br>μs<br>μs | 7-bits setting.<br>9-bits setting.<br>10-bits setting.<br>12-bits setting. |
| Power Consumption   |     | 1.2                          |     | mA                   |  |

**5.11 Control AC Characteristics**

T<sub>A</sub>= -40°C to 85°C, VDD=2.0V to 3.6V if nothing else stated.

**Table 14: Control Inputs AC Characteristics**

| Parameter  | Min                 | Typ | Max | Unit | Condition/Note   |
|--|---------------------|-----|-----|------|--|
| System clock,<br>f <sub>SYSCLK</sub><br>t <sub>SYSCLK</sub> = 1/ f <sub>SYSCLK</sub> | 16                  |     | 32  | MHz  | System clock is 32 MHz when crystal oscillator is used. System clock is 16 MHz when calibrated 16 MHz RC oscillator is used.   |
| RESET_N low width  | 250                 |     |     | ns   | See item 1, Figure 1. This is the shortest pulse that is guaranteed to be recognized as a complete reset pin request. Note that shorter pulses may be recognized but will not lead to complete reset of all modules within the chip. |
| Interrupt pulse width  | t <sub>SYSCLK</sub> |     |     | ns   | See item 2, Figure 1. This is the shortest pulse that is guaranteed to be recognized as an interrupt request. In PM2/3 the internal synchronizers are bypassed so this requirement does not apply in PM2/3.                          |

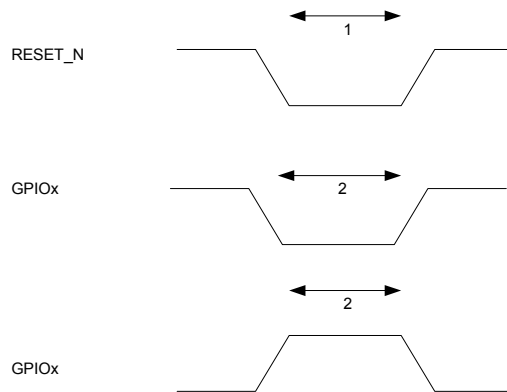

**Figure 1: Control Inputs AC Characteristics**

## 5.12 SPI AC Characteristics

T<sub>A</sub>= -40°C to 85°C, VDD=2.0V to 3.6V if nothing else stated.

**Table 15: SPI AC Characteristics**

| Parameter       | Min                   | Typ | Max | Unit | Condition/Note                    |
|-----------------|-----------------------|-----|-----|------|-----------------------------------|
| SSN low to SCK  | 2*t <sub>SYSCLK</sub> |     |     |      | See item 5 Figure 2               |
| SCK to SSN high | 30                    |     |     | ns   | See item 6 Figure 2               |
| SCK period      | 100                   |     |     | ns   | See item 1 Figure 2               |
| SCK duty cycle  |                       | 50% |     |      |                                   |
| SI setup        | 10                    |     |     | ns   | See item 2 Figure 2               |
| SI hold         | 10                    |     |     | ns   | See item 3 Figure 2               |
| SCK to SO       |                       |     | 25  | ns   | See item 4 Figure 2, load = 10 pF |

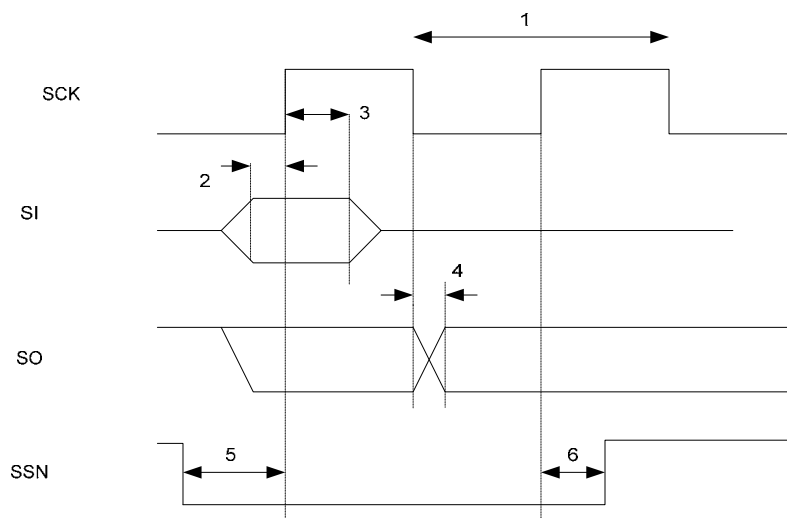

**Figure 2: SPI AC Characteristics**

## 5.13 Port Outputs AC Characteristics

T<sub>A</sub>= 25°C, VDD=3.0V if nothing else stated.

**Table 16: Port Outputs AC Characteristics**

| Parameter                               | Min | Typ           | Max | Unit | Condition/Note  |
|---|-----|---------------|-----|------|---|
| GPIO/USART output rise time (SC=0/SC=1) |     | 3.15/<br>1.34 |     | ns   | Load = 10 pF<br>Timing is with respect to 10% VDD and 90% VDD levels.<br>Values are estimated |
| fall time (SC=0/SC=1)                   |     | 3.2/<br>1.44  |     |      | Load = 10 pF<br>Timing is with respect to 90% VDD and 10% VDD.<br>Values are estimated        |

## 5.14 DC Characteristics

The DC Characteristics of **CCZACC06** are listed in Table 17 below.

T<sub>A</sub>=25°C, VDD=3.0V if nothing else stated.

**Table 17: DC Characteristics**

| Digital Inputs/Outputs                 | Min | Typ | Max | Unit | Condition                   |
|--|-----|-----|-----|------|-----------------------------|
| Logic "0" input voltage                |     |     | 30  | %    | Of VDD supply (2.0 – 3.6 V) |
| Logic "1" input voltage                | 70  |     |     | %    | Of VDD supply (2.0 – 3.6 V) |
| Logic "0" input current per pin        | NA  |     | 12  | nA   | Input equals 0V             |
| Logic "1" input current                | NA  |     | 12  | nA   | Input equals VDD            |
| Total logic "0" input current all pins |     |     | 70  | nA   |                             |
| Total logic "1" input current all pins |     |     | 70  | nA   |                             |
| I/O pin pull-up and pull-down resistor |     | 20  |     | kΩ   |                             |

## 6 Pin and I/O Port Configuration

The *CCZACC06* pinout is shown in Figure 3 with details in Table 18.

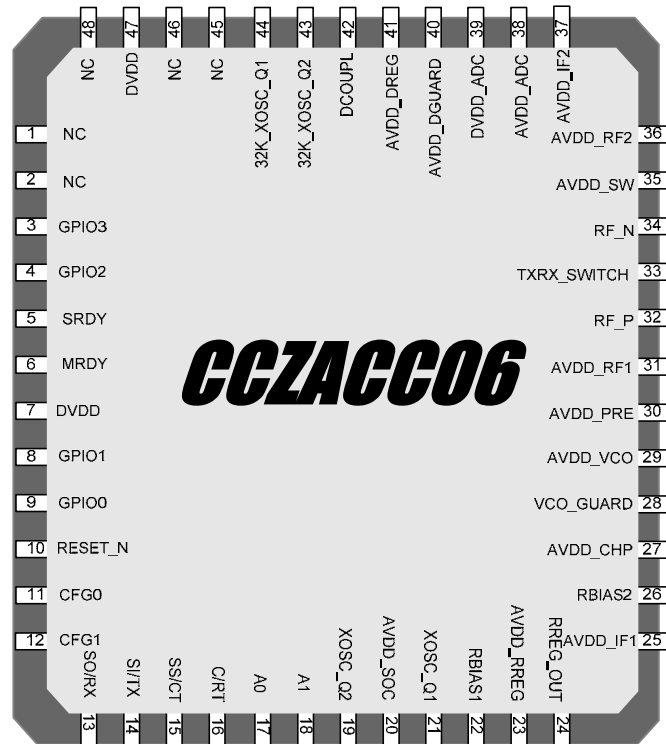

Figure 3: Pinout top view

Note: The exposed die attach pad **must** be connected to a solid ground plane as this is the ground connection for the chip.

**Table 18: Pinout overview**

| Pin | Pin name    | Pin type        | Description  |
|-----|-------------|-----------------|--|
| -   | GND         | Ground          | The exposed die attach pad must be connected to a solid ground plane   |
| 1   | NC          | N/A             |  |
| 2   | NC          | N/A             |  |
| 3   | GPIO3       | Digital I/O     | General I/O pin 3  |
| 4   | GPIO2       | Digital I/O     | General I/O pin 2  |
| 5   | SRDY        | Digital Output  | Slave ready. Mandatory for SPI, optional for UART.   |
| 6   | MRDY        | Digital Input   | Master ready. Optional for SPI and UART.   |
| 7   | DVDD        | Power (Digital) | 2.0V-3.6V digital power supply for digital I/O   |
| 8   | GPIO1       | Digital I/O     | General I/O pin 1 – increased drive capability   |
| 9   | GPIO0       | Digital I/O     | General I/O pin 0 – increased drive capability   |
| 10  | RESET_N     | Digital input   | Reset, active low  |
| 11  | CFG0        | Digital Input   | Configuration input 0  |
| 12  | CFG1        | Digital Input   | Configuration input 1  |
| 13  | SO/RX       | Digital Input   | SPI slave output or UART RX data   |
| 14  | SI/TX       | Digital Output  | SPI slave input or UART TX data  |
| 15  | SS/CT       | Digital I/O     | SPI slave select (in) or UART CTS (out)  |
| 16  | C/RT        | Digital Input   | SPI clock or UART RTS  |
| 17  | A0          | Analog Input    | ADC input A0   |
| 18  | A1          | Analog Input    | ADC input A1   |
| 19  | XOSC_Q2     | Analog I/O      | 32 MHz crystal oscillator pin 2  |
| 20  | AVDD_SOC    | Power (Analog)  | 2.0V-3.6V analog power supply connection   |
| 21  | XOSC_Q1     | Analog I/O      | 32 MHz crystal oscillator pin 1, or external clock input   |
| 22  | RBIAS1      | Analog I/O      | External precision bias resistor for reference current   |
| 23  | AVDD_RREG   | Power (Analog)  | 2.0V-3.6V analog power supply connection   |
| 24  | RREG_OUT    | Power output    | 1.8V Voltage regulator power supply output. Only intended for supplying the analog 1.8V part (power supply for pins 25, 27-31, 35-40). |
| 25  | AVDD_IF1    | Power (Analog)  | 1.8V Power supply for the receiver band pass filter, analog test module, global bias and first part of the VGA                         |
| 26  | RBIAS2      | Analog output   | External precision resistor, 43 k $\Omega$ , $\pm 1$ %   |
| 27  | AVDD_CHP    | Power (Analog)  | 1.8V Power supply for phase detector, charge pump and first part of loop filter  |
| 28  | VCO_GUARD   | Power (Analog)  | Connection of guard ring for VCO (to AVDD) shielding   |
| 29  | AVDD_VCO    | Power (Analog)  | 1.8V Power supply for VCO and last part of PLL loop filter   |
| 30  | AVDD_PRE    | Power (Analog)  | 1.8V Power supply for Prescaler, Div-2 and LO buffers  |
| 31  | AVDD_RF1    | Power (Analog)  | 1.8V Power supply for LNA, front-end bias and PA   |
| 32  | RF_P        | RF I/O          | Positive RF input signal to LNA during RX. Positive RF output signal from PA during TX   |
| 33  | TXRX_SWITCH | Power (Analog)  | Regulated supply voltage for PA  |
| 34  | RF_N        | RF I/O          | Negative RF input signal to LNA during RX<br>Negative RF output signal from PA during TX   |
| 35  | AVDD_SW     | Power (Analog)  | 1.8V Power supply for LNA / PA switch  |
| 36  | AVDD_RF2    | Power (Analog)  | 1.8V Power supply for receive and transmit mixers  |
| 37  | AVDD_IF2    | Power (Analog)  | 1.8V Power supply for transmit low pass filter and last stages of VGA  |
| 38  | AVDD_ADC    | Power (Analog)  | 1.8V Power supply for analog parts of ADCs and DACs  |
| 39  | DVDD_ADC    | Power (Digital) | 1.8V Power supply for digital parts of ADCs  |
| 40  | AVDD_DGUARD | Power (Digital) | Power supply connection for digital noise isolation  |
| 41  | AVDD_DREG   | Power (Digital) | 2.0V-3.6V digital power supply for digital core voltage regulator  |
| 42  | DCOUP       | Power (Digital) | 1.8V digital power supply decoupling. Do not use for supplying external circuits.  |
| 43  | 32K_XOSC_Q2 | Analog I/O      | 32.768 kHz XOSC  |
| 44  | 32K_XOSC_Q1 | Analog I/O      | 32.768 kHz XOSC  |
| 45  | NC          | N/A             |  |
| 46  | NC          | N/A             |  |
| 47  | DVDD        | Power (Digital) | 2.0V-3.6V digital power supply for digital I/O   |
| 48  | NC          | N/A             |  |

7 Circuit Description

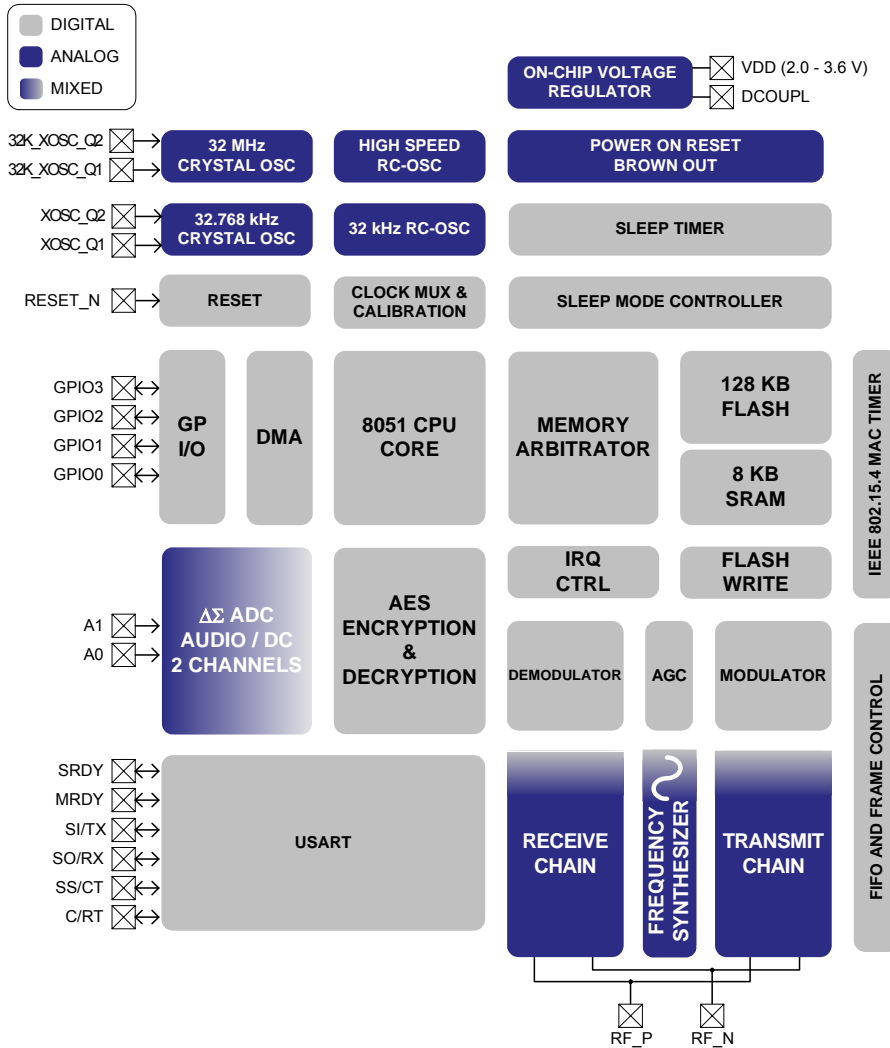

Figure 4: CCZACC06 Block Diagram

A block diagram of *CCZACC06* is shown in Figure 4. The modules can be roughly divided into one of three categories: CPU-related modules, modules related to power and clock

distribution, and radio-related modules. *CCZACC06* features an IEEE 802.15.4 compliant radio based on the leading *CC2420* transceiver. See Section 10 for details.

## 8 Application Circuit

Few external components are required for the operation of **CCZACC06**. A typical application circuit is shown in Figure 5. Typical values and

description of external components are shown in Table 19.

### 8.1 Input / output matching

The RF input/output is high impedance and differential. The optimum differential load for the RF port is  $60 + j164 \Omega^4$ .

LNA (RX) and the PA (TX). See Input/output matching section on page 33 for more details.

When using an unbalanced antenna such as a monopole, a balun should be used in order to optimize performance. The balun can be implemented using low-cost discrete inductors and capacitors. The recommended balun shown, consists of C341, L341, L321 and L331 together with a PCB microstrip transmission line ( $\lambda/2$ -dipole), and will match the RF input/output to  $50 \Omega$ . An internal T/R switch circuit is used to switch between the

If a balanced antenna such as a folded dipole is used, the balun can be omitted. If the antenna also provides a DC path from TXRX\_SWITCH pin to the RF pins, inductors are not needed for DC bias.

Figure 5 shows a suggested application circuit using a differential antenna. The antenna type is a standard folded dipole. The dipole has a virtual ground point; hence bias is provided without degradation in antenna performance. Also refer to the section Antenna Considerations on page 35.

<sup>4</sup> This is for 2440MHz.

### 8.2 Bias resistors

The bias resistors are R221 and R261. The bias resistor R221 is used to set an accurate bias current for the 32 MHz crystal oscillator.

### 8.3 Crystal

An external 32 MHz crystal, XTAL1, with two loading capacitors (C191 and C211) is used for the 32 MHz crystal oscillator. See page 10 for details. The load capacitance seen by the 32 MHz crystal is given by:

$$C_L = \frac{1}{\frac{1}{C_{191}} + \frac{1}{C_{211}}} + C_{parasitic}$$

XTAL2 is an optional 32.768 kHz crystal, with two loading capacitors (C441 and C431), used for the 32.768 kHz crystal oscillator. The 32.768 kHz crystal oscillator is used in applications where you need both very low

sleep current consumption and accurate wake up times. The load capacitance seen by the 32.768 kHz crystal is given by:

$$C_L = \frac{1}{\frac{1}{C_{441}} + \frac{1}{C_{431}}} + C_{parasitic}$$

A series resistor may be used to comply with the ESR requirement.

### 8.4 Voltage regulators

The on chip voltage regulators supply all 1.8 V power supply pins and internal power supplies.

C241 and C421 are required for stability of the regulators.

8.5 Power supply decoupling and filtering

Proper power supply decoupling must be used for optimum performance. The placement and size of the decoupling capacitors and the power supply filtering are very important to achieve the best performance in an application. TI provides a compact reference design that should be followed very closely.

Refer to the section PCB Layout Recommendation on page 35.

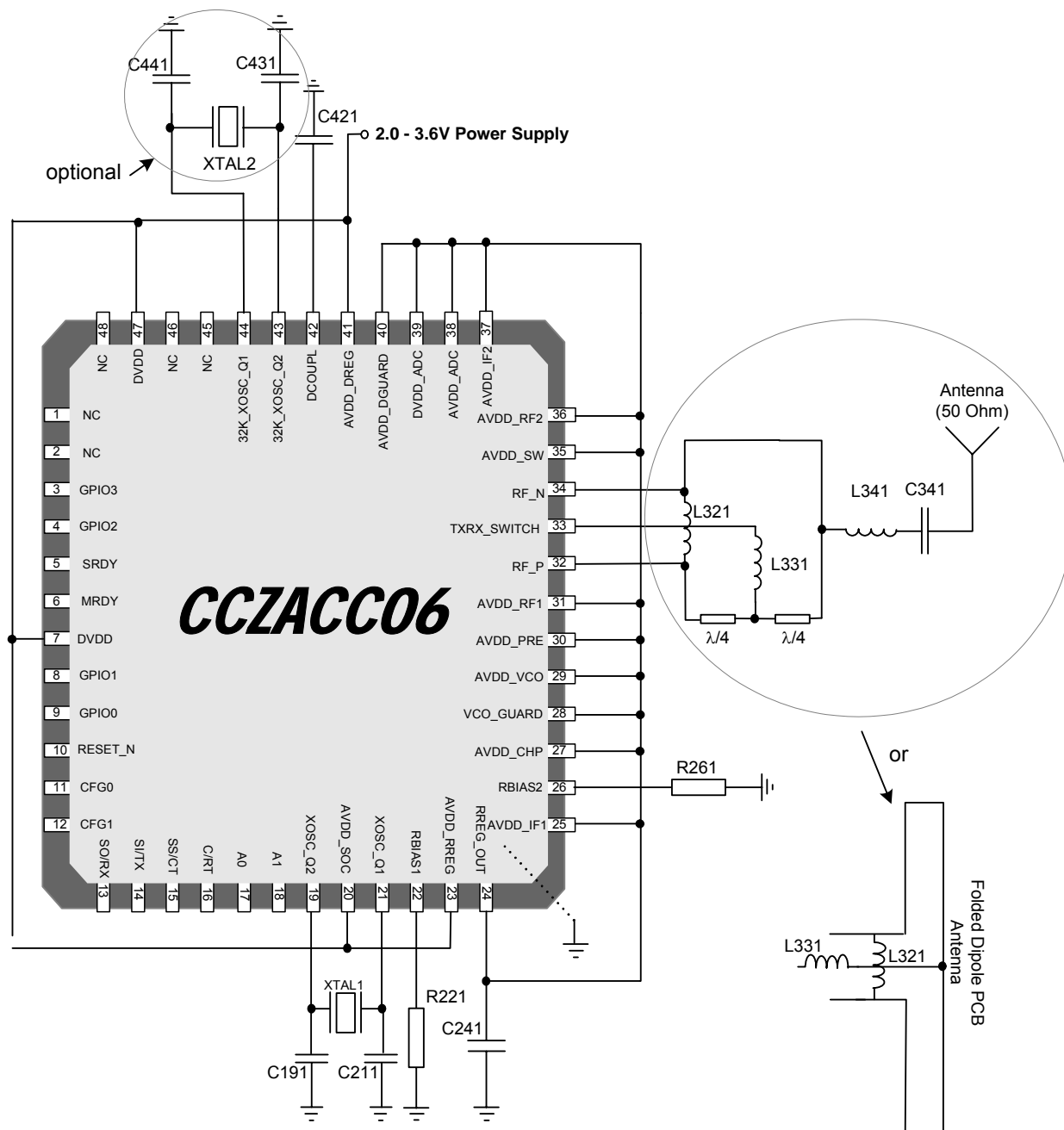

Figure 5: CCZACC06 Application Circuit. (Digital I/O and ADC interface not connected). Decoupling capacitors not shown.

**Table 19: Overview of external components (excluding supply decoupling capacitors)**

| Component  | Description   | Single Ended 50Ω Output  | Differential Antenna                   |
|------------|---|--|--|
| C191       | 32 MHz crystal load capacitor   | 33 pF, 5%, NP0, 0402   | 33 pF, 5%, NP0, 0402                   |
| C211       | 32 MHz crystal load capacitor   | 27 pF, 5%, NP0, 0402   | 27 pF, 5%, NP0, 0402                   |
| C241       | Load capacitance for analogue power supply voltage regulators   | 220 nF, 10%, 0402  | 220 nF, 10%, 0402                      |
| C421       | Load capacitance for digital power supply voltage regulators  | 1 μF, 10%, 0402  | 1 μF, 10%, 0402                        |
| C341       | DC block to antenna and match<br>Note: For RF connector a LP filter can be connected between this C, the antenna and good ground in order to remove conducted spurious emission by using 1.8pF in parallel with 1.6nH | 5.6 pF, 5%, NP0, 0402  | Not used                               |
|            |   | 1.8 pF, Murata COG 0402, GRM15<br>1.6 nH, Murata 0402, LQG15HS1N6S02 |  |
| C431, C441 | 32.768 kHz crystal load capacitor (if low-frequency crystal is needed in application)   | 15 pF, 5%, NP0, 0402   | 15 pF, 5%, NP0, 0402                   |
| L321       | Discrete balun and match  | 6.8 nH, 5%, Monolithic/multilayer, 0402                              | 12 nH 5%, Monolithic/multilayer, 0402  |
| L331       | Discrete balun and match  | 22 nH, 5%, Monolithic/multilayer, 0402                               | 27 nH, 5%, Monolithic/multilayer, 0402 |
| L341       | Discrete balun and match  | 1.8 nH, +/-0.3 nH, Monolithic/multilayer, 0402                       | Not used                               |
| R221       | Precision resistor for current reference generator to system-on-chip part   | 56 kΩ, 1%, 0402  | 56 kΩ, 1%, 0402                        |
| R261       | Precision resistor for current reference generator to RF part   | 43 kΩ, 1%, 0402  | 43 kΩ, 1%, 0402                        |
| XTAL1      | 32 MHz Crystal  | 32 MHz crystal, ESR < 60 Ω   | 32 MHz crystal, ESR < 60 Ω             |
| XTAL2      | Optional 32.768 kHz watch crystal (if low-frequency crystal is needed in application)   | 32.768 kHz crystal, Epson MC 306.                                    | 32.768 kHz crystal, Epson MC 306.      |

## 9 Peripherals

In the following sub-sections the user-accessible **CCZACC06** peripheral modules are described in detail.

### 9.1 Reset

The **CCZACC06** has four reset sources. The following events generate a reset:

- Forcing RESET\_N input pin low
- A power-on reset condition
- A brown-out reset condition
- A firmware-generated reset (SYS\_RESET\_REQ [2])

The initial conditions after a reset are as follows:

- I/O pins are configured as inputs with pull-up
- See the **CCZACC06** user guide [2] for a description of the interaction between CCZACC06 and the host processor after reset.

#### 9.1.1 Power On Reset and Brown Out Detector

The **CCZACC06** includes a Power On Reset (POR) providing correct initialization during device power-on. Also includes is a Brown Out Detector (BOD) operating on the regulated 1.8V digital power supply only. The BOD will protect the memory contents during supply voltage variations which cause the regulated 1.8V power to drop below the minimum level required by flash memory and SRAM.

state until the supply voltage reaches above the Power On Reset and Brown Out voltages.

Figure 6 shows the POR/BOD operation with the 1.8V (typical) regulated supply voltage together with the active low reset signals BOD\_RESET and POR\_RESET shown in the bottom of the figure (note that signals are not available, just for illustration of events).

When power is initially applied to the **CCZACC06** the Power On Reset (POR) and Brown Out Detector (BOD) will hold the device in reset

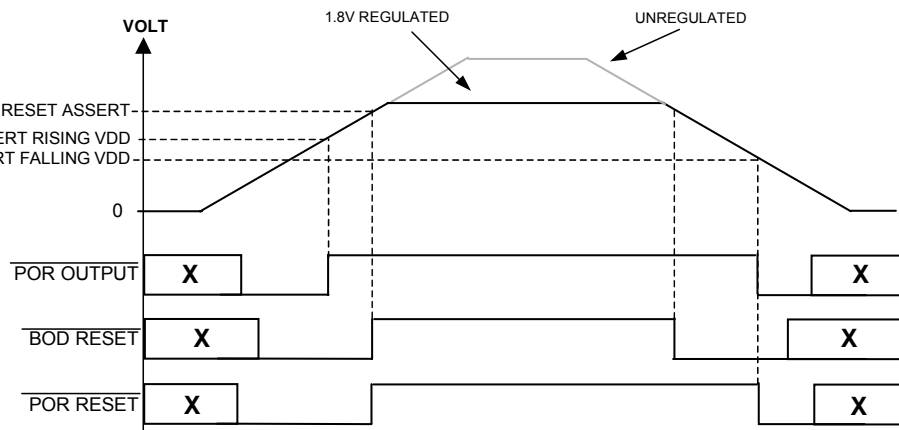

**Figure 6 : Power On Reset and Brown Out Detector Operation**

### 9.2 I/O ports

The **CCZACC06** has digital input/output pins that have the following key features:

- General purpose I/O or peripheral I/O
- Pull-up or pull-down capability on inputs
- External interrupt capability

Two of the I/O pins have external interrupts that can be used to wake up the device from sleep modes.

### 9.2.1 *Unused I/O pins*

Unused I/O pins should have a defined level and not be left floating. One way to do this is to leave the pin unconnected and configured with

pull-up resistor. This is also the state of all pins after reset.

### 9.2.2 *Low I/O Supply Voltage*

In applications where the digital I/O power supply voltage pin DVDD is below 2.6 V, the SC bit should be set to 1 in order to obtain output DC characteristics specified in section

5.14. See the **CCZACC06** user guide [2] for a description of how to do this.

### 9.2.3 *General Purpose I/O*

See the **CCZACC06** user guide [2] for a description of how to configure and use the GPIO pins.

The output drive strength is 4 mA on all outputs, except for the two high-drive outputs, GPIO0 and GPIO1, which each have ~20 mA output drive strength.

When used as an input, the general purpose I/O port pins can be configured to have a pull-up, pull-down or tri-state mode of operation. By

default, after a reset, inputs are configured as inputs with pull-up. Please note that GPIO0 and GPIO1 do not have pull-up or pull-down capabilities.

In power modes PM2 and PM3 the I/O pins retain the I/O mode and output value (if applicable) that was set when PM2/3 was entered

### 9.3 ADC

#### 9.3.1 ADC Introduction

The ADC supports up to 12-bit analog-to-digital conversion. The ADC includes an analog multiplexer with up to two individually configurable channels and reference voltage generator.

The main features of the ADC are as follows:

- Selectable decimation rates which also sets the resolution (7 to 12 bits).
- Two individual input channels, single-ended or differential
- Internal voltage reference
- Temperature sensor input
- Battery measurement capability

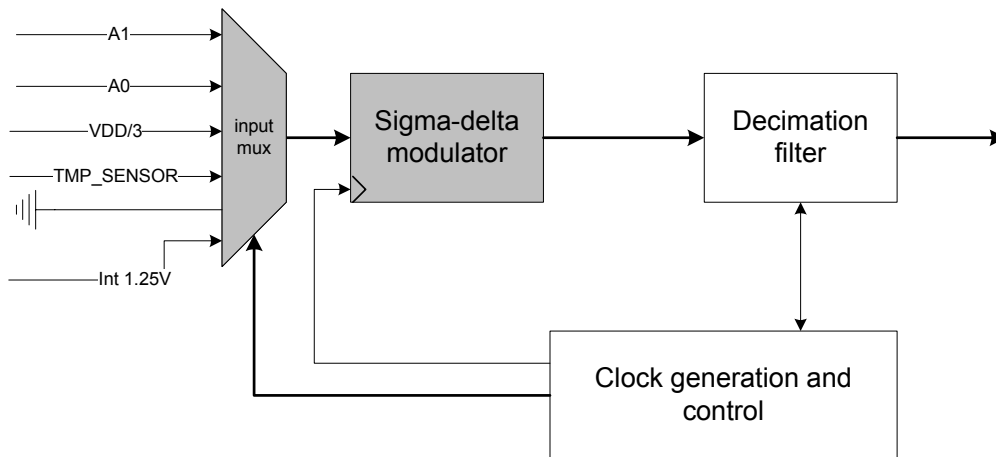

Figure 7: ADC block diagram.

#### 9.3.2 ADC Operation

This section describes the general setup and operation of the ADC.

##### 9.3.2.1 ADC Core

The ADC includes an ADC capable of converting an analog input into a digital representation with up to 12 bits resolution.

The ADC uses a selectable positive reference voltage.

##### 9.3.2.2 ADC Inputs

The signals from input pins A0 and A1 are used as single-ended ADC inputs. The ADC automatically performs a sequence of conversions when the SYS\_ADC\_READ command is issued.

selected as an input to the ADC for temperature measurements.

It is also possible to select a voltage corresponding to AVDD\_SOC/3 as an ADC input. This input allows the implementation of e.g. a battery monitor in applications where this feature is required.

In addition to the input pins A0-1, the output of an on-chip temperature sensor can be

##### 9.3.2.3 ADC conversion sequences

The CCZACC06 has two ADC channels that are connected to external pins. Additionally, the ADC can measure the chip voltage and temperature.

In the case where differential inputs are selected, the differential inputs consist of the input pair A0-1. Note that no negative supply can be applied to these pins, nor a supply larger than VDD (unregulated power). It is the difference between the pairs that are converted in differential mode.

The ADC conversions are done channel by channel incrementally.

The two external pin inputs A0 and A1 can be used as single-ended or differential inputs.

In addition to the input pins A0-1, the output of an on-chip temperature sensor can be selected as an input to the ADC for temperature measurements.

#### 9.3.2.4 *ADC Operating Modes*

This section describes the operating modes and initialization of conversions.

The ADC uses an internal voltage reference for single-ended conversions.

#### 9.3.2.5 *ADC Conversion Results*

The digital conversion result is represented in two's complement form. The result is always positive. This is because the result is the difference between ground and input signal which is always positively signed ( $V_{conv} = V_{inp} - V_{inn}$ , where  $V_{inn} = 0V$ ). The maximum value is reached when the input amplitude is equal  $V_{REF}$ , the internal voltage reference.

#### 9.3.2.6 *ADC Reference Voltage*

The positive reference voltage for analog-to-digital conversions is an internally generated 1.25V voltage.

#### 9.3.2.7 *ADC Conversion Timing*

The ADC is run on the 32MHz system clock, which is divided by 8 to give a 4 MHz clock.

The time required to perform a conversion depends on the selected decimation rate. When the decimation rate is set to for instance 128, the decimation filter uses exactly 128 of the 4 MHz clock periods to calculate the result. When a conversion is started, the input

It is also possible to select a voltage corresponding to  $AVDD\_SOC/3$  as an ADC input. This input allows the implementation of e.g. a battery monitor in applications where this feature is required.

The decimation rate (and thereby also the resolution and time required to complete a conversion and sample rate) is configurable from 7-12 bits.

For differential configurations the difference between the pins is converted and this difference can be negatively signed. For 12-bit resolution the digital conversion result is 2047 when the analog input,  $V_{conv}$ , is equal to  $V_{REF}$ , and the conversion result is -2048 when the analog input is equal to  $-V_{REF}$ .

multiplexer is allowed 16 4 MHz clock cycles to settle in case the channel has been changed since the previous conversion. The 16 clock cycles settling time applies to all decimation rates. Thus in general, the conversion time is given by:

$$T_{conv} = (\text{decimation rate} + 16) \times 0.25 \mu\text{s}.$$

**9.4 Random Number Generator**

*9.4.1 Introduction*

The random number generator has the following features.

- Generate pseudo-random bytes which can be read by the external microprocessor.

The random number generator is a 16-bit Linear Feedback Shift Register (LFSR) with polynomial  $X^{16} + X^{15} + X^2 + 1$  (i.e. CRC16). It uses different levels of unrolling depending on the operation it performs. The basic version (no unrolling) is shown in Figure 8.

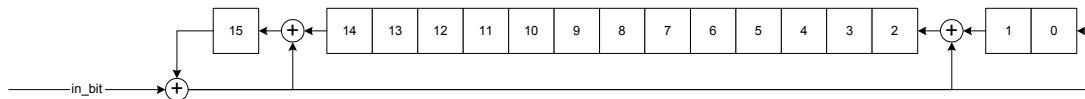

**Figure 8: Basic structure of the Random Number Generator**

*9.4.2 Semi random sequence generation*

The operation is to clock the LFSR once (13x unrolling) each time the external microprocessor reads the random value. This

leads to the availability of a fresh pseudo-random byte from the LSB end of the LFSR.

## 9.5 USART

The USART is a serial communications interface that can be operated in either

asynchronous UART mode or in synchronous SPI mode.

### 9.5.1 UART mode

For asynchronous serial interfaces, the UART mode is provided. In the UART mode the interface uses a two-wire or four-wire interface consisting of the pins RXD, TXD and optionally RTS and CTS. The UART mode of operation is as follows:

- Baud rate: 115200.
- Hardware (RTS/CTS) flow control.

- 8N1 byte format.
- DCE signal connection.

The UART mode provides full duplex asynchronous transfers, and the synchronization of bits in the receiver does not interfere with the transmit function. A UART byte transfer consists of a start bit, eight data bits, a parity bit, and one stop bit.

### 9.5.2 SPI Mode

This section describes the SPI mode of operation for synchronous communication. In SPI mode, the USART communicates with an external system through a 3-wire or 4-wire interface. The interface consists of the pins SI, SO, SCK and SS\_N. The SPI mode is as follows:

- SPI slave.
- Clock speed up to 4 MHz.
- Clock polarity 0 and clock phase 0 on **CCZACC06**.
- Bit order: MSB first.

#### 9.5.2.1 SPI Slave Operation

An SPI byte transfer in slave mode is controlled by the external system. The data on the SI input is shifted into the receive register controlled by the serial clock SCK which is an

input in slave mode. At the same time the byte in the transmit register is shifted out onto the SO output.

#### 9.5.3 SSN Slave Select Pin

When the USART is operating in SPI mode, configured as an SPI slave, a 4-wire interface is used with the Slave Select (SSN) pin as an input to the SPI (edge controlled). At falling edge of SSN the SPI slave is active and receives data on the SI input and outputs data on the SO output. At rising edge of SSN, the SPI slave is inactive and will not receive data.

Note that the SO output is not tri-stated after rising edge on SSn. This could be achieved using an external buffer. Also note that release of SSn (rising edge) must be aligned to end of byte received or sent. If released in a byte the next received byte will not be received properly as information about previous byte is present in SPI system.

10 Radio

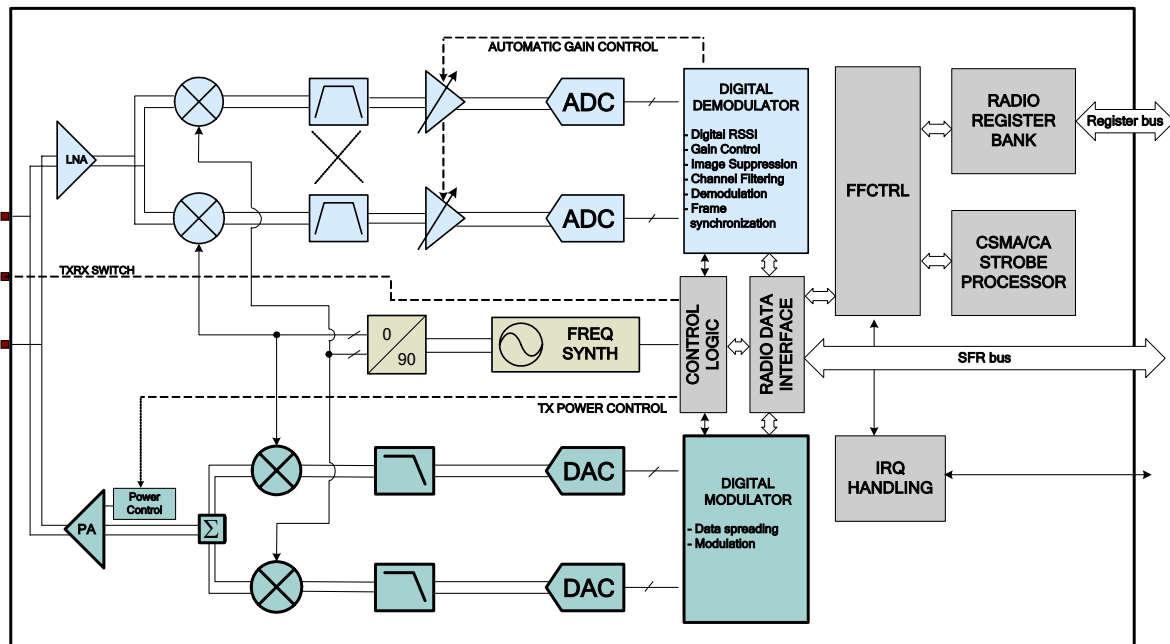

Figure 9: CCZACC06 Radio Module

A simplified block diagram of the IEEE 802.15.4 compliant radio inside *CCZACC06* is shown in Figure 9. The radio core is based on the industry leading *CC2420* RF transceiver.

*CCZACC06* features a low-IF receiver. The received RF signal is amplified by the low-noise amplifier (LNA) and down-converted in quadrature (I and Q) to the intermediate frequency (IF). At IF (2 MHz), the complex I/Q signal is filtered and amplified, and then digitized by the RF receiver ADCs.

The *CCZACC06* transmitter is based on direct up-conversion. The preamble and start of frame delimiter are generated in hardware. Each symbol (4 bits) is spread using the IEEE 802.15.4 spreading sequence to 32 chips and output to the digital-to-analog converters (DACs).

An analog low pass filter passes the signal to the quadrature (I and Q) up-conversion mixers.

The RF signal is amplified in the power amplifier (PA) and fed to the antenna.

The internal T/R switch circuitry makes the antenna interface and matching easy. The RF connection is differential. A balun may be used for single-ended antennas. The biasing of the PA and LNA is done by connecting `TXRX_SWITCH` to `RF_P` and `RF_N` through an external DC path.

The frequency synthesizer includes a completely on-chip LC VCO and a 90 degrees phase splitter for generating the I and Q LO signals to the down-conversion mixers in receive mode and up-conversion mixers in transmit mode. The VCO operates in the frequency range 4800 – 4966 MHz, and the frequency is divided by two when split into I and Q signals.

An on-chip voltage regulator delivers the regulated 1.8 V supply voltage.

**10.1 IEEE 802.15.4 Modulation Format**

This section is meant as an introduction to the 2.4 GHz direct sequence spread spectrum (DSSS) RF modulation format defined in IEEE 802.15.4. For a complete description, please refer to [1].

The modulation and spreading functions are illustrated at block level in Figure 10 [1]. Each byte is divided into two symbols, 4 bits each. The least significant symbol is transmitted first.

For multi-byte fields, the least significant byte is transmitted first.

Each symbol is mapped to one out of 16 pseudo-random sequences, 32 chips each. The symbol to chip mapping is shown in Table 20. The chip sequence is then transmitted at 2 MChips/s, with the least significant chip ( $C_0$ ) transmitted first for each symbol.

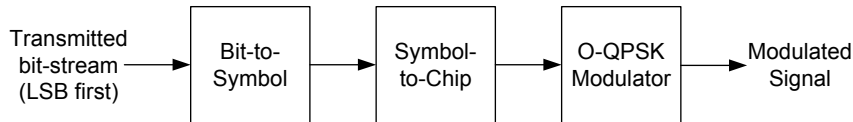

**Figure 10: Modulation and spreading functions [1]**

The modulation format is Offset – Quadrature Phase Shift Keying (O-QPSK) with half-sine chip shaping. This is equivalent to MSK modulation. Each chip is shaped as a half-

sine, transmitted alternately in the I and Q channels with one half chip period offset. This is illustrated for the zero-symbol in Figure 11.

**Table 20: IEEE 802.15.4 symbol-to-chip mapping [1]**

| Symbol | Chip sequence ( $C_0, C_1, C_2, \dots, C_{31}$ )                    |
|--------|---|
| 0      | 1 1 0 1 1 0 0 1 1 1 0 0 0 0 1 1 0 1 0 1 0 1 0 0 1 0 0 0 1 0 1 1 1 0 |
| 1      | 1 1 1 0 1 1 0 1 1 0 0 1 1 1 0 0 0 0 1 1 0 1 0 1 0 0 1 0 0 0 1 0     |
| 2      | 0 0 1 0 1 1 1 0 1 1 0 1 1 0 0 1 1 1 0 0 0 0 1 1 0 1 0 1 0 0 1 0     |
| 3      | 0 0 1 0 0 0 1 0 1 1 1 0 1 1 0 1 1 0 0 1 1 1 0 0 0 0 1 1 0 1 0 1     |
| 4      | 0 1 0 1 0 0 1 0 0 0 1 0 1 1 1 0 1 1 0 1 1 0 0 1 1 1 0 0 0 0 1 1     |
| 5      | 0 0 1 1 0 1 0 1 0 0 1 0 0 0 1 0 1 1 1 0 1 1 0 1 1 0 0 1 1 1 0 0     |
| 6      | 1 1 0 0 0 0 1 1 0 1 0 1 0 0 1 0 0 0 1 0 1 1 1 0 1 1 0 1 1 0 0 1     |
| 7      | 1 0 0 1 1 1 0 0 0 0 1 1 0 1 0 1 0 0 1 0 0 0 1 0 1 1 1 0 1 1 0 1     |
| 8      | 1 0 0 0 1 1 0 0 1 0 0 1 0 1 1 0 0 0 0 0 1 1 1 0 1 1 1 1 0 1 1       |
| 9      | 1 0 1 1 1 0 0 0 1 1 0 0 1 0 0 1 0 1 1 0 0 0 0 0 0 1 1 1 0 1 1 1     |
| 10     | 0 1 1 1 1 0 1 1 1 0 0 0 1 1 0 0 1 0 0 1 0 1 1 0 0 0 0 0 0 0 1 1 1   |
| 11     | 0 1 1 1 0 1 1 1 1 0 1 1 1 0 0 0 1 1 0 0 1 0 0 1 0 1 0 1 1 0 0 0 0   |
| 12     | 0 0 0 0 0 1 1 1 0 1 1 1 1 0 1 1 1 0 0 0 1 1 0 0 1 0 0 1 0 1 1 0     |
| 13     | 0 1 1 0 0 0 0 0 0 1 1 1 0 1 1 1 1 0 1 1 1 0 0 0 1 1 0 0 1 0 0 1     |
| 14     | 1 0 0 1 0 1 1 0 0 0 0 0 0 1 1 1 0 1 1 1 1 0 1 1 1 0 0 0 1 1 0 0     |
| 15     | 1 1 0 0 1 0 0 1 0 1 1 0 0 0 0 0 0 1 1 1 0 1 1 1 1 0 1 1 1 0 0 0     |

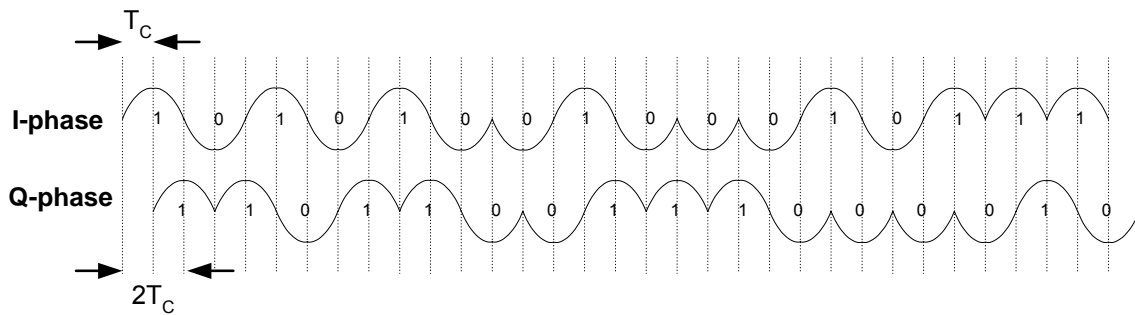

Figure 11: I/Q Phases when transmitting a zero-symbol chip sequence,  $T_c = 0.5 \mu s$

### 10.2 Demodulator, Symbol Synchronizer and Data Decision

The block diagram for the *CCZACC06* demodulator is shown in Figure 12. Channel filtering and frequency offset compensation is performed digitally. The signal level in the channel is estimated to generate the RSSI level. Data filtering is also included for enhanced performance.

With the  $\pm 40$  ppm frequency accuracy requirement from [1], a compliant receiver must be able to compensate for up to 80 ppm or 200 kHz. The *CCZACC06* demodulator tolerates up to 300 kHz offset without significant degradation of the receiver performance.

Soft decision is used at the chip level, i.e. the demodulator does not make a decision for each chip, only for each received symbol. De-spreading is performed using over-sampling symbol correlators. Symbol synchronization is achieved by a continuous start of frame delimiter (SFD) search.

The *CCZACC06* demodulator also handles symbol rate errors in excess of 120 ppm without performance degradation. Resynchronization is performed continuously to adjust for error in the incoming symbol rate.

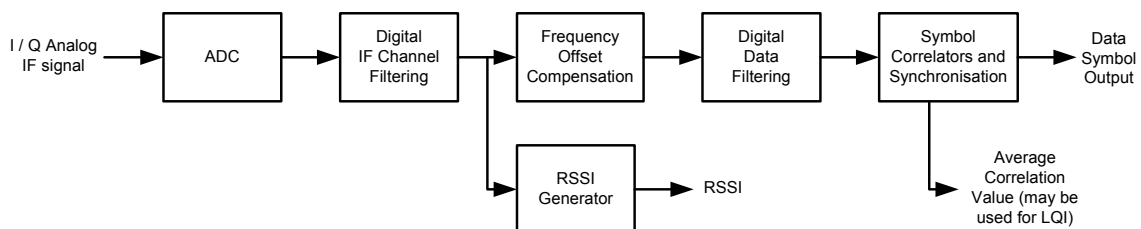
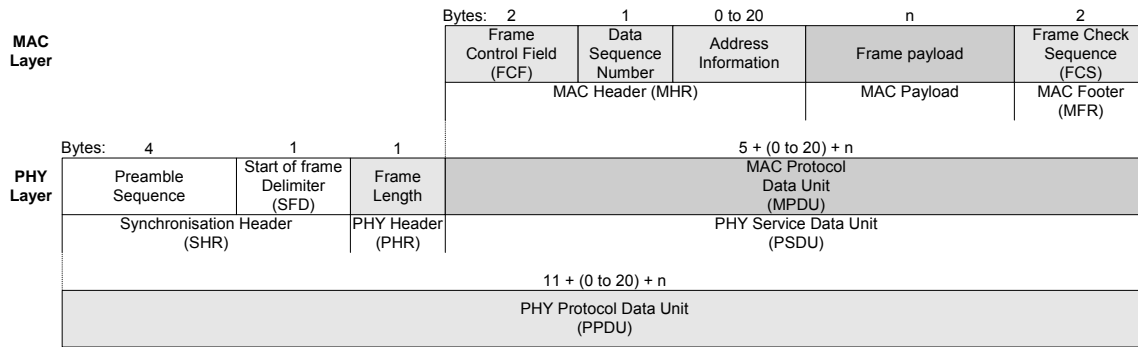

Figure 12: Demodulator Simplified Block Diagram

### 10.3 Frame Format

*CCZACC06* has hardware support for parts of the IEEE 802.15.4 frame format. This section gives a brief summary to the IEEE 802.15.4 frame format, and describes how *CCZACC06* is set up to comply with this.

Figure 13 [1] shows a schematic view of the IEEE 802.15.4 frame format. Similar figures describing specific frame formats (data frames, beacon frames, acknowledgment frames and MAC command frames) are included in [1].



**Figure 13: Schematic view of the IEEE 802.15.4 Frame Format [1]**

**10.4 Synchronization header**

The synchronization header (SHR) consists of the preamble sequence followed by the start of frame delimiter (SFD). In [1], the preamble sequence is defined to be four bytes of 0x00. The SFD is one byte, set to 0xA7.

A synchronization header is always transmitted first in all transmit modes.

In receive mode *CCZACC06* uses the preamble sequence for symbol synchronization and frequency offset adjustments. The SFD is used for byte synchronization.

**10.5 MAC protocol data unit**

The FCF, data sequence number and address information follows the length field as shown in Figure 13. Together with the MAC data payload and Frame Check Sequence, they form the MAC Protocol Data Unit (MPDU).

The format of the FCF is shown in Figure 14. Please refer to [1] for details.

| Bits: 0-2  | 3                | 4             | 5                   | 6         | 7-9      | 10-11                       | 12-13    | 14-15                  |
|------------|------------------|---------------|---------------------|-----------|----------|-----------------------------|----------|------------------------|
| Frame Type | Security Enabled | Frame Pending | Acknowledge request | Intra PAN | Reserved | Destination addressing mode | Reserved | Source addressing mode |

**Figure 14: Format of the Frame Control Field (FCF) [1]**

**10.6 Frame check sequence**

A 2-byte frame check sequence (FCS) follows the last MAC payload byte as shown in Figure 13. The FCS is calculated over the MPDU, i.e. the length field is not part of the FCS.

The *CCZACC06* hardware implementation is shown in Figure 15. Please refer to [1] for further details.

The FCS polynomial is [1]:

$$x^{16} + x^{12} + x^5 + 1$$

In transmit mode the FCS is appended at the correct position defined by the length field.

The most significant bit in the last byte of each frame is set high if the CRC of the received frame is correct and low otherwise.

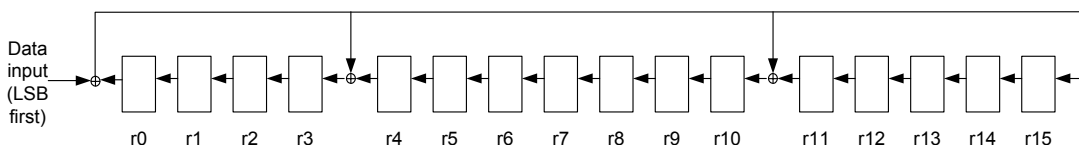

**Figure 15: CCZACC06 Frame Check Sequence (FCS) hardware implementation [1]**

## 10.7 Linear IF and AGC Settings

*CCZACC06* is based on a linear IF chain where the signal amplification is done in an analog VGA (variable gain amplifier). The gain of the VGA is digitally controlled.

The AGC (Automatic Gain Control) loop ensures that the ADC operates inside its dynamic range by using an analog/digital feedback loop.

## 10.8 Clear Channel Assessment

The clear channel assessment signal is based on the measured RSSI value and a programmable threshold. The clear channel assessment function is used to implement the

CSMA-CA functionality specified in [1]. CCA is valid when the receiver has been enabled for at least 8 symbol periods.

## 10.9 VCO and PLL Self-Calibration

### 10.9.1 VCO

The VCO is completely integrated and operates at 4800 – 4966 MHz. The VCO frequency is divided by 2 to generate

frequencies in the desired band (2400-2483.5 MHz).

### 10.9.2 PLL self-calibration

The VCO's characteristics will vary with temperature, changes in supply voltages, and the desired operating frequency.

In order to ensure reliable operation the VCO's bias current and tuning range are automatically calibrated every time the RX mode or TX mode is enabled.

## 10.10 Input / Output Matching

The RF input / output is differential (*RF\_N* and *RF\_P*). In addition there is supply switch output pin (*TXRX\_SWITCH*) that must have an external DC path to *RF\_N* and *RF\_P*.

The RF output and DC bias can be done using different topologies. Some are shown in Figure 5 on page 21.

In RX mode the *TXRX\_SWITCH* pin is at ground and will bias the LNA. In TX mode the *TXRX\_SWITCH* pin is at supply rail voltage and will properly bias the internal PA.

Component values are given in Table 19 on page 22. If a differential antenna is implemented, no balun is required.

If a single ended output is required (for a single ended connector or a single ended antenna), a balun should be used for optimum performance.

## 10.11 System Considerations and Guidelines

### 10.11.1 SRD regulations

International regulations and national laws regulate the use of radio receivers and transmitters. SRDs (Short Range Devices) for license free operation are allowed to operate in the 2.4 GHz band worldwide. The most

important regulations are ETSI EN 300 328 and EN 300 440 (Europe), FCC CFR-47 part 15.247 and 15.249 (USA), and ARIB STD-T66 (Japan).

### 10.11.2 Frequency hopping and multi-channel systems

The 2.4 GHz band is shared by many systems both in industrial, office and home environments. **CCZACC06** uses direct sequence spread spectrum (DSSS) as defined by [1] to

spread the output power, thereby making the communication link more robust even in a noisy environment.

### 10.11.3 Crystal accuracy and drift

A crystal accuracy of  $\pm 40$  ppm is required for compliance with IEEE 802.15.4 [1]. This accuracy must also take ageing and temperature drift into consideration.

ppm total frequency offset between the transmitter and receiver. This could e.g. relax the accuracy requirement to 60 ppm for each of the devices.

A crystal with low temperature drift and low aging could be used without further compensation. A trimmer capacitor in the crystal oscillator circuit (in parallel with C191 in Figure 5) could be used to set the initial frequency accurately.

Optionally in a star network topology, the full-function device (FFD) could be equipped with a more accurate crystal thereby relaxing the requirement on the reduced-function device (RFD). This can make sense in systems where the reduced-function devices ship in higher volumes than the full-function devices.

For non-IEEE 802.15.4 systems, the robust demodulator in **CCZACC06** allows up to 140

### 10.11.4 Communication robustness

**CCZACC06** provides very good adjacent, alternate and co channel rejection, image frequency suppression and blocking properties. The **CCZACC06** performance is significantly better than the requirements

imposed by [1]. These are highly important parameters for reliable operation in the 2.4 GHz band, since an increasing number of devices/systems are using this license free frequency band.

### 10.11.5 Communication security

The hardware encryption and authentication operations in **CCZACC06** enable secure communication, which is required for many applications. Security operations require a lot of data processing, which is costly in an 8-bit

microcontroller system. The hardware support within **CCZACC06** enables a high level of security with minimum CPU processing requirements.

### 10.11.6 Low cost systems

As the **CCZACC06** provides 250 kbps multi-channel performance without any external filters, a very low cost system can be made (e.g. two layer PCB with single-sided component mounting).

A differential antenna will eliminate the need for a balun, and the DC biasing can be achieved in the antenna topology.

### 10.11.7 Battery operated systems

In low power applications, the **CCZACC06** should be placed in the low-power modes PM2 or PM3 when not active. Ultra low power

consumption may be achieved since the voltage regulators are turned off.

## 10.12 PCB Layout Recommendation

In the Texas Instruments reference design, the top layer is used for signal routing, and the open areas are filled with metallization connected to ground using several vias. The area under the chip is used for grounding and must be well connected to the ground plane with several vias.

The ground pins should be connected to ground as close as possible to the package pin using individual vias. The de-coupling capacitors should also be placed as close as possible to the supply pins and connected to the ground plane by separate vias. Supply power filtering is very important.

## 10.13 Antenna Considerations

*CCZACC06* can be used together with various types of antennas. A differential antenna like a dipole would be the easiest to interface not needing a balun (balanced to un-balanced transformation network).

The length of the  $\lambda/2$ -dipole antenna is given by:

$$L = 14250 / f$$

where f is in MHz, giving the length in cm. An antenna for 2450 MHz should be 5.8 cm. Each arm is therefore 2.9 cm.

Other commonly used antennas for short-range communication are monopole, helical and loop antennas. The single-ended monopole and helical would require a balun network between the differential output and the antenna.

Monopole antennas are resonant antennas with a length corresponding to one quarter of the electrical wavelength ( $\lambda/4$ ). They are very easy to design and can be implemented simply as a "piece of wire" or even integrated into the PCB.

The length of the  $\lambda/4$ -monopole antenna is given by:

$$L = 7125 / f$$

where f is in MHz, giving the length in cm. An antenna for 2450 MHz should be 2.9 cm.

Non-resonant monopole antennas shorter than  $\lambda/4$  can also be used, but at the expense of range. In size and cost critical applications such an antenna may very well be integrated into the PCB.

Enclosing the antenna in high dielectric constant material reduces the overall size of

The external components should be as small as possible (0402 is recommended) and surface mount devices must be used.

If using any external high-speed digital devices, caution should be used when placing these in order to avoid interference with the RF circuitry.

It is strongly advised that this reference layout is followed very closely in order to obtain the best performance.

The schematic, BOM and layout Gerber files for the reference designs are all available from the TI website.

the antenna. Many vendors offer such antennas intended for PCB mounting.

Helical antennas can be thought of as a combination of a monopole and a loop antenna. They are a good compromise in size critical applications. Helical antennas tend to be more difficult to optimize than the simple monopole.

Loop antennas are easy to integrate into the PCB, but are less effective due to difficult impedance matching because of their very low radiation resistance.

For low power applications the differential antenna is recommended giving the best range and because of its simplicity.

The antenna should be connected as close as possible to the IC. If the antenna is located away from the RF pins the antenna should be matched to the feeding transmission line ( $50\Omega$ ).

## 11 Voltage Regulators

The **CCZACC06** includes two low drop-out voltage regulators. These are used to provide a 1.8 V power supply to the **CCZACC06** analog and digital power supplies.

*Note: It is recommended that the voltage regulators are not used to provide power to external circuits. This is because of limited power sourcing capability and due to noise considerations. External circuitry can be powered if they can be used when internal power consumption is low and can be set I PD mode when internal power consumption I high.*

### 11.1 Voltage Regulators Power-on

When the analog voltage regulator is powered-on before use of the radio, there will be a delay before the regulator is enabled.

The analog voltage regulator input pin `AVDD_RREG` is to be connected to the unregulated 2.0 to 3.6 V power supply. The regulated 1.8 V voltage output to the analog parts, is available on the `RREG_OUT` pin. The digital regulator input pin `AVDD_DREG` is also to be connected to the unregulated 2.0 to 3.6 V power supply. The output of the digital regulator is connected internally within the **CCZACC06** to the digital power supply.

The voltage regulators require external components as described in section 8 on page 20.

The digital voltage regulator is disabled when the **CCZACC06** is placed in low power modes to reduce power consumption.

**12 Package Description (QLP 48)**

All dimensions are in millimeters, angles in degrees. NOTE: The **CCZACC06** is available in RoHS lead-free package only. Compliant with JEDEC MS-020.

**Table 21: Package dimensions**

| Quad Leadless Package (QLP) |     |     |      |     |      |     |      |     |      |      |
|-----------------------------|-----|-----|------|-----|------|-----|------|-----|------|------|
|                             |     | D   | D1   | E   | E1   | e   | b    | L   | D2   | E2   |
| QLP 48                      | Min | 6.9 | 6.65 | 6.9 | 6.65 | 0.5 | 0.18 | 0.3 | 5.05 | 5.05 |
|                             | Max | 7.1 | 6.85 | 7.1 | 6.85 |     |      |     | 5.10 | 5.10 |

The overall package height is 0.85 +/- 0.05  
All dimensions in mm

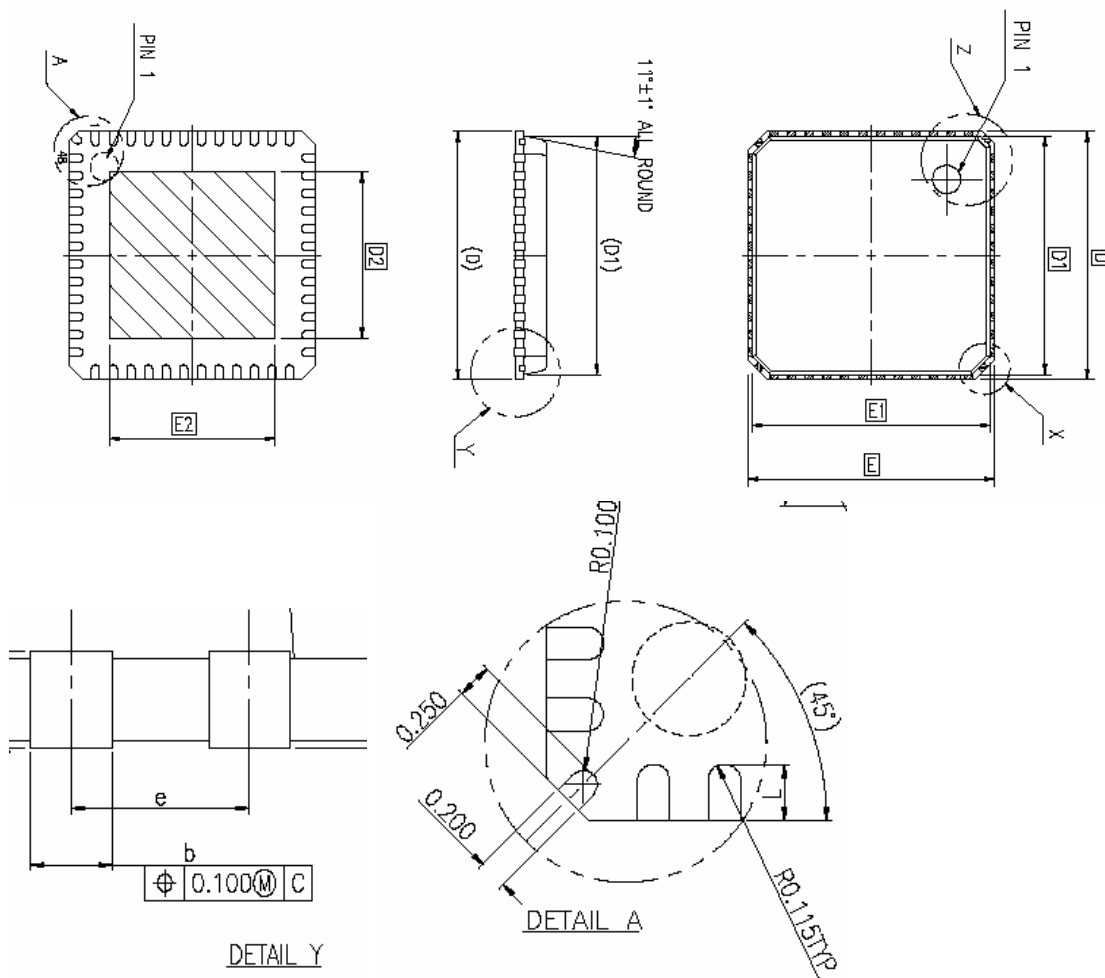

**Figure 16: Package dimensions drawing**



**Table 24: Carrier tape and reel specification**

| Tape and Reel Specification |            |                 |            |               |                |
|-----------------------------|------------|-----------------|------------|---------------|----------------|
| Package                     | Tape Width | Component Pitch | Hole Pitch | Reel Diameter | Units per Reel |
| QLP 48                      | 16mm       | 12mm            | 4mm        | 13 inches     | 2500           |

## 13 Ordering Information

**Table 25: Ordering Information**

| Ordering part number | Description   | MOQ   |
|----------------------|---|-------|
| CCZACC06A1RTC        | CCZACC06, QLP48 package, RoHS compliant Pb-free assembly, trays with 260 pcs per tray, ZigBee 2006 Network Processor. | 260   |
| CCZACC06A1RTCR       | CCZACC06, QLP48 package, RoHS compliant Pb-free assembly, T&R with 2500 pcs per reel, ZigBee 2006 Network Processor.  | 2,500 |
| eZ430-RFZACC06       | CCZACC06 Demonstration Board based on the eZ430-RF platform   | 1     |

MOQ = Minimum Order Quantity

T&R = tape and reel

## 14 General Information

### 14.1 Document History

**Table 26: Document History**

| Revision | Date       | Description/Changes                    |
|----------|------------|--|
| 1.0      | 2008-03-02 | First data sheet for released product. |

## 15 Address Information

Texas Instruments Norway AS  
 Gaustadalléen 21  
 N-0349 Oslo  
 NORWAY  
 Tel: +47 22 95 85 44  
 Fax: +47 22 95 85 46  
 Web site: <http://www.ti.com/lpw>

## 16 TI Worldwide Technical Support

### Internet

TI Semiconductor Product Information Center Home Page: [support.ti.com](http://support.ti.com)  
 TI Semiconductor KnowledgeBase Home Page: [support.ti.com/sc/knowledgebase](http://support.ti.com/sc/knowledgebase)

### Product Information Centers

#### Americas

**Phone:** +1(972) 644-5580  
**Fax:** +1(972) 927-6377  
**Internet/Email:** [support.ti.com/sc/pic/americas.htm](http://support.ti.com/sc/pic/americas.htm)

#### Europe, Middle East and Africa

**Phone:**  
 Belgium (English) +32 (0) 27 45 54 32  
 Finland (English) +358 (0) 9 25173948  
 France +33 (0) 1 30 70 11 64  
 Germany +49 (0) 8161 80 33 11  
 Israel (English) 180 949 0107  
 Italy 800 79 11 37  
 Netherlands (English) +31 (0) 546 87 95 45  
 Russia +7 (0) 95 363 4824  
 Spain +34 902 35 40 28  
 Sweden (English) +46 (0) 8587 555 22  
 United Kingdom +44 (0) 1604 66 33 99  
**Fax:** +49 (0) 8161 80 2045  
**Internet:** [support.ti.com/sc/pic/euro.htm](http://support.ti.com/sc/pic/euro.htm)

## Japan

|                       |               |  |
|-----------------------|---------------|--|
| <b>Fax</b>            | International | +81-3-3344-5317  |
|                       | Domestic      | 0120-81-0036   |
| <b>Internet/Email</b> | International | <a href="http://support.ti.com/sc/pic/japan.htm">support.ti.com/sc/pic/japan.htm</a> |
|                       | Domestic      | <a href="http://www.tij.co.jp/pic">www.tij.co.jp/pic</a>                             |

## Asia

|                 |                  |  |
|-----------------|------------------|--|
| <b>Phone</b>    | International    | +886-2-23786800  |
|                 | Domestic         | <u>Toll-Free Number</u>  |
|                 | Australia        | 1-800-999-084  |
|                 | China            | 800-820-8682   |
|                 | Hong Kon         | 800-96-5941  |
|                 | India            | +91-80-51381665 (Toll)   |
|                 | Indonesia        | 001-803-8861-1006  |
|                 | Korea            | 080-551-2804   |
|                 | Malaysia         | 1-800-80-3973  |
|                 | New Zealand      | 0800-446-934   |
|                 | Philippines      | 1-800-765-7404   |
|                 | Singapore        | 800-886-1028   |
|                 | Taiwan           | 0800-006800  |
| Thailand        | 001-800-886-0010 |  |
| <b>Fax</b>      |                  | +886-2-2378-6808   |
| <b>Email</b>    |                  | <a href="mailto:tiasia@ti.com">tiasia@ti.com</a> or <a href="mailto:ti-china@ti.com">ti-china@ti.com</a> |
| <b>Internet</b> |                  | <a href="http://support.ti.com/sc/pic/asia.htm">support.ti.com/sc/pic/asia.htm</a>                       |

RTC (S-PQFP-N48)

PLASTIC QUAD FLATPACK

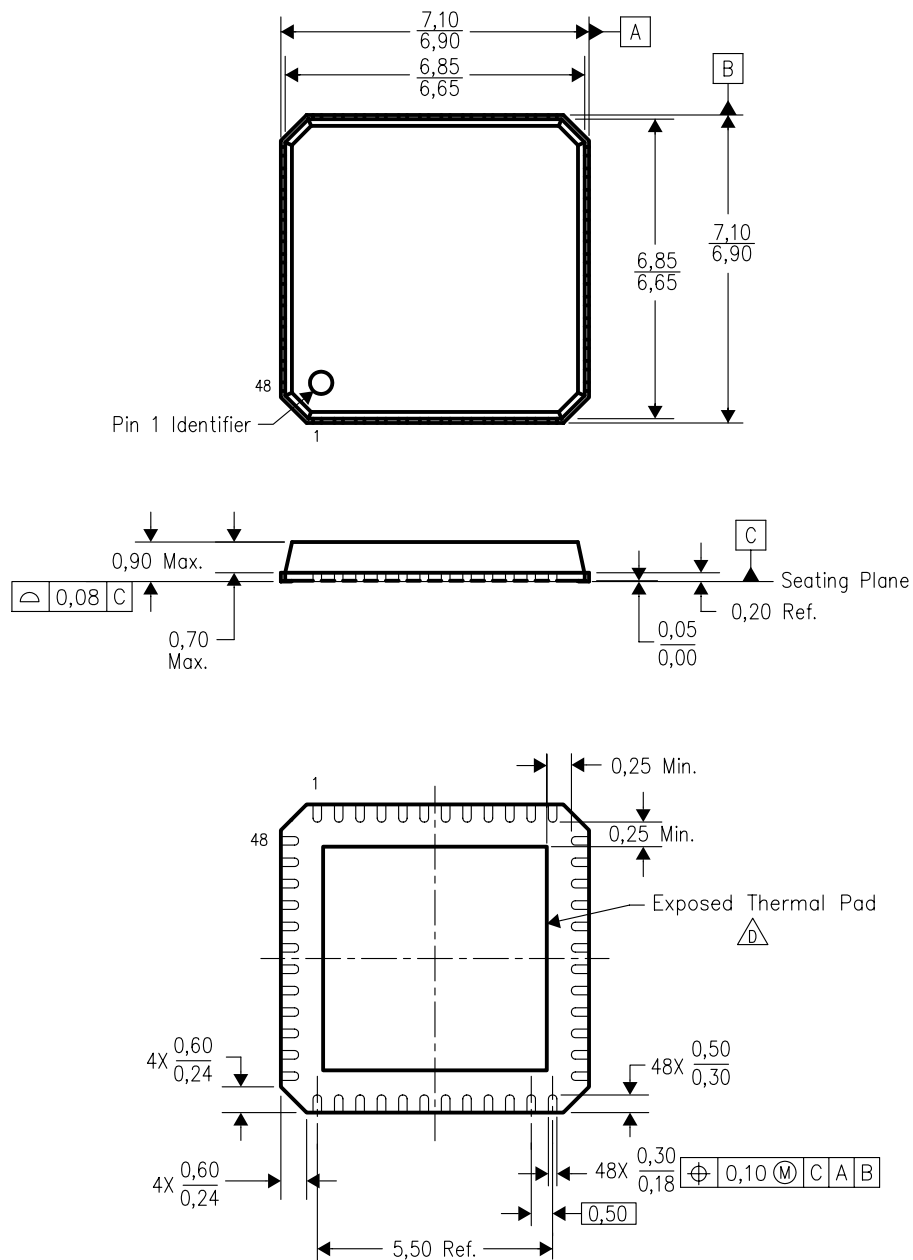

4205143/B 11/04

- NOTES:
- A. All linear dimensions are in millimeters. Dimensioning and tolerancing per ASME Y14.5M-1994.
  - B. This drawing is subject to change without notice.
  - C. QFN (Quad Flatpack No-Lead) Package configuration.
  -  The package thermal pad must be soldered to the board for thermal and mechanical performance. See the Product Data Sheet for details regarding the exposed thermal pad dimensions.

## IMPORTANT NOTICE

Texas Instruments Incorporated and its subsidiaries (TI) reserve the right to make corrections, modifications, enhancements, improvements, and other changes to its products and services at any time and to discontinue any product or service without notice. Customers should obtain the latest relevant information before placing orders and should verify that such information is current and complete. All products are sold subject to TI's terms and conditions of sale supplied at the time of order acknowledgment.

TI warrants performance of its hardware products to the specifications applicable at the time of sale in accordance with TI's standard warranty. Testing and other quality control techniques are used to the extent TI deems necessary to support this warranty. Except where mandated by government requirements, testing of all parameters of each product is not necessarily performed.

TI assumes no liability for applications assistance or customer product design. Customers are responsible for their products and applications using TI components. To minimize the risks associated with customer products and applications, customers should provide adequate design and operating safeguards.

TI does not warrant or represent that any license, either express or implied, is granted under any TI patent right, copyright, mask work right, or other TI intellectual property right relating to any combination, machine, or process in which TI products or services are used. Information published by TI regarding third-party products or services does not constitute a license from TI to use such products or services or a warranty or endorsement thereof. Use of such information may require a license from a third party under the patents or other intellectual property of the third party, or a license from TI under the patents or other intellectual property of TI.

Reproduction of TI information in TI data books or data sheets is permissible only if reproduction is without alteration and is accompanied by all associated warranties, conditions, limitations, and notices. Reproduction of this information with alteration is an unfair and deceptive business practice. TI is not responsible or liable for such altered documentation. Information of third parties may be subject to additional restrictions.

Resale of TI products or services with statements different from or beyond the parameters stated by TI for that product or service voids all express and any implied warranties for the associated TI product or service and is an unfair and deceptive business practice. TI is not responsible or liable for any such statements.

TI products are not authorized for use in safety-critical applications (such as life support) where a failure of the TI product would reasonably be expected to cause severe personal injury or death, unless officers of the parties have executed an agreement specifically governing such use. Buyers represent that they have all necessary expertise in the safety and regulatory ramifications of their applications, and acknowledge and agree that they are solely responsible for all legal, regulatory and safety-related requirements concerning their products and any use of TI products in such safety-critical applications, notwithstanding any applications-related information or support that may be provided by TI. Further, Buyers must fully indemnify TI and its representatives against any damages arising out of the use of TI products in such safety-critical applications.

TI products are neither designed nor intended for use in military/aerospace applications or environments unless the TI products are specifically designated by TI as military-grade or "enhanced plastic." Only products designated by TI as military-grade meet military specifications. Buyers acknowledge and agree that any such use of TI products which TI has not designated as military-grade is solely at the Buyer's risk, and that they are solely responsible for compliance with all legal and regulatory requirements in connection with such use.

TI products are neither designed nor intended for use in automotive applications or environments unless the specific TI products are designated by TI as compliant with ISO/TS 16949 requirements. Buyers acknowledge and agree that, if they use any non-designated products in automotive applications, TI will not be responsible for any failure to meet such requirements.

Following are URLs where you can obtain information on other Texas Instruments products and application solutions:

### Products

|                             |  |
|-----------------------------|--|
| Amplifiers                  | <a href="http://amplifier.ti.com">amplifier.ti.com</a>             |
| Data Converters             | <a href="http://dataconverter.ti.com">dataconverter.ti.com</a>     |
| DSP                         | <a href="http://dsp.ti.com">dsp.ti.com</a>                         |
| Clocks and Timers           | <a href="http://www.ti.com/clocks">www.ti.com/clocks</a>           |
| Interface                   | <a href="http://interface.ti.com">interface.ti.com</a>             |
| Logic                       | <a href="http://logic.ti.com">logic.ti.com</a>                     |
| Power Mgmt                  | <a href="http://power.ti.com">power.ti.com</a>                     |
| Microcontrollers            | <a href="http://microcontroller.ti.com">microcontroller.ti.com</a> |
| RFID                        | <a href="http://www.ti-rfid.com">www.ti-rfid.com</a>               |
| RF/IF and ZigBee® Solutions | <a href="http://www.ti.com/lprf">www.ti.com/lprf</a>               |

### Applications

|                    |  |
|--------------------|--|
| Audio              | <a href="http://www.ti.com/audio">www.ti.com/audio</a>                   |
| Automotive         | <a href="http://www.ti.com/automotive">www.ti.com/automotive</a>         |
| Broadband          | <a href="http://www.ti.com/broadband">www.ti.com/broadband</a>           |
| Digital Control    | <a href="http://www.ti.com/digitalcontrol">www.ti.com/digitalcontrol</a> |
| Medical            | <a href="http://www.ti.com/medical">www.ti.com/medical</a>               |
| Military           | <a href="http://www.ti.com/military">www.ti.com/military</a>             |
| Optical Networking | <a href="http://www.ti.com/opticalnetwork">www.ti.com/opticalnetwork</a> |
| Security           | <a href="http://www.ti.com/security">www.ti.com/security</a>             |
| Telephony          | <a href="http://www.ti.com/telephony">www.ti.com/telephony</a>           |
| Video & Imaging    | <a href="http://www.ti.com/video">www.ti.com/video</a>                   |
| Wireless           | <a href="http://www.ti.com/wireless">www.ti.com/wireless</a>             |

Mailing Address: Texas Instruments, Post Office Box 655303, Dallas, Texas 75265  
Copyright © 2008, Texas Instruments Incorporated

## Looking for pricing, stock, or lifecycle information?

Click below to explore more details on WIN SOURCE:

- ⊖ [View CCZACC06A1RTCR on WIN SOURCE](#)
- ⊖ [Texas Instruments Information](#)

## Optimize Your Supply Chain with WIN SOURCE Solutions

- ✓ Global Sourcing Solution
- ✓ Obsolete Management
- ✓ Cost Control Management
- ✓ Shortage Management
- ✓ Alternative Solution
- ✓ Excess Inventory Management