



**THE DATASHEET OF  
KAF-1001-AAA-CP-B2**



# KAF-1001

## 1024 (H) x 1024 (V) Full Frame CCD Image Sensor

### Description

The KAF-1001 Image Sensor is a high-performance charge-coupled device (CCD) designed for a wide range of image sensing applications.

The sensor incorporates true two-phase CCD technology, simplifying the support circuits required to drive the sensor as well as reducing dark current without compromising charge capacity. The sensor also utilizes the TRUESENSE Transparent Gate Electrode to improve sensitivity compared to the use of a standard front side illuminated polysilicon electrode.

Selectable on-chip output amplifiers allow operation to be optimized for different imaging needs: Low Noise (when using the high-sensitivity output) or Maximum Dynamic Range (when using the low-sensitivity output).

**Table 1. GENERAL SPECIFICATIONS**

Parameter	Typical Value
Architecture	Full Frame CCD
Pixel Count	1024 (H) x 1024 (V)
Pixel Size	24 $\mu\text{m}$ (H) x 24 $\mu\text{m}$ (V)
Active Image Size	24.6 mm (H) x 24.6 mm (V) 34.8 mm (Diagonal) APS-H Optical Format
Chip Size	28.6 mm (H) x 25.5 mm (V)
Optical Fill-Factor	100%
Saturation Signal High Sensitivity Output High Dynamic Range	240,000 electrons 650,000 electrons
Output Sensitivity High Sensitivity Output High Dynamic Range	11 $\mu\text{V}$ /electron 2 $\mu\text{V}$ /electron
Readout Noise (1 MHz)	15 electrons rms
Dark Current (25°C, Accumulation Mode)	< 30 pA/cm <sup>2</sup>
Dark Current Doubling Rate	5–6°C
Dynamic Range (Sat Sig/Dar Noise) High Sensitivity Output High Dynamic Range	83 dB 97 dB
Quantum Efficiency (450, 550, 650 nm)	40%, 55%, 65%
Maximum Data Rate High Sensitivity Output High Dynamic Range	5 MHz 2 MHz
Transfer Efficiency (2 MHz, to -40°C)	> 0.99997
Package	CERDIP Package (Sidebrazed)
Cover Glass	Clear

NOTE: Parameters above are specified at T = 25°C unless otherwise noted.



**ON Semiconductor®**

[www.onsemi.com](http://www.onsemi.com)

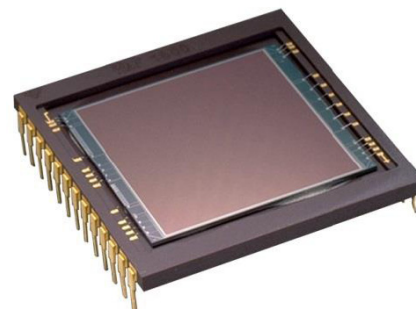

**Figure 1. KAF-1001 CCD Image Sensor**

### Features

- True Two Phase Full Frame Architecture
- TRUESENSE Transparent Gate Electrode for High Sensitivity
- 100% Fill Factor
- Low Dark Current
- Single Readout Register
- User-selectable Outputs Allow either Low Noise or High Dynamic Range Operation

### Applications

- Scientific
- Medical

### ORDERING INFORMATION

See detailed ordering and shipping information on page 2 of this data sheet.

# KAF-1001

## ORDERING INFORMATION

**Table 2. ORDERING INFORMATION – KAF-1001 IMAGE SENSOR**

Part Number	Description	Marking Code
KAF-1001-AAA-CP-B1	Monochrome, No Microlens, CERDIP Package (Sidebrazed), Taped Clear Cover Glass (No Coatings), Grade 1	KAF-1001-AAA Serial Number
KAF-1001-AAA-CP-B2	Monochrome, No Microlens, CERDIP Package (Sidebrazed), Taped Clear Cover Glass (No Coatings), Grade 2	
KAF-1001-AAA-CP-AE	Monochrome, No Microlens, CERDIP Package (Sidebrazed), Taped Clear Cover Glass (No Coatings), Engineering Sample	
KAF-1001-AAA-CB-AE	Monochrome, No Microlens, CERDIP Package (Sidebrazed), Clear Cover Glass (No Coatings), Engineering Sample	
KAF-1001-AAA-CB-B2	Monochrome, No Microlens, CERDIP Package (Sidebrazed), Clear Cover Glass (No Coatings), Grade 2	

**Table 3. ORDERING INFORMATION – EVALUATION SUPPORT**

Part Number	Description
KEK-4H0080-KAF-1001-12-5	Evaluation Board (Complete Kit)

See the ON Semiconductor *Device Nomenclature* document (TND310/D) for a full description of the naming convention used for image sensors. For reference documentation, including information on evaluation kits, please visit our web site at [www.onsemi.com](http://www.onsemi.com).

# KAF-1001

## DEVICE DESCRIPTION

### Architecture

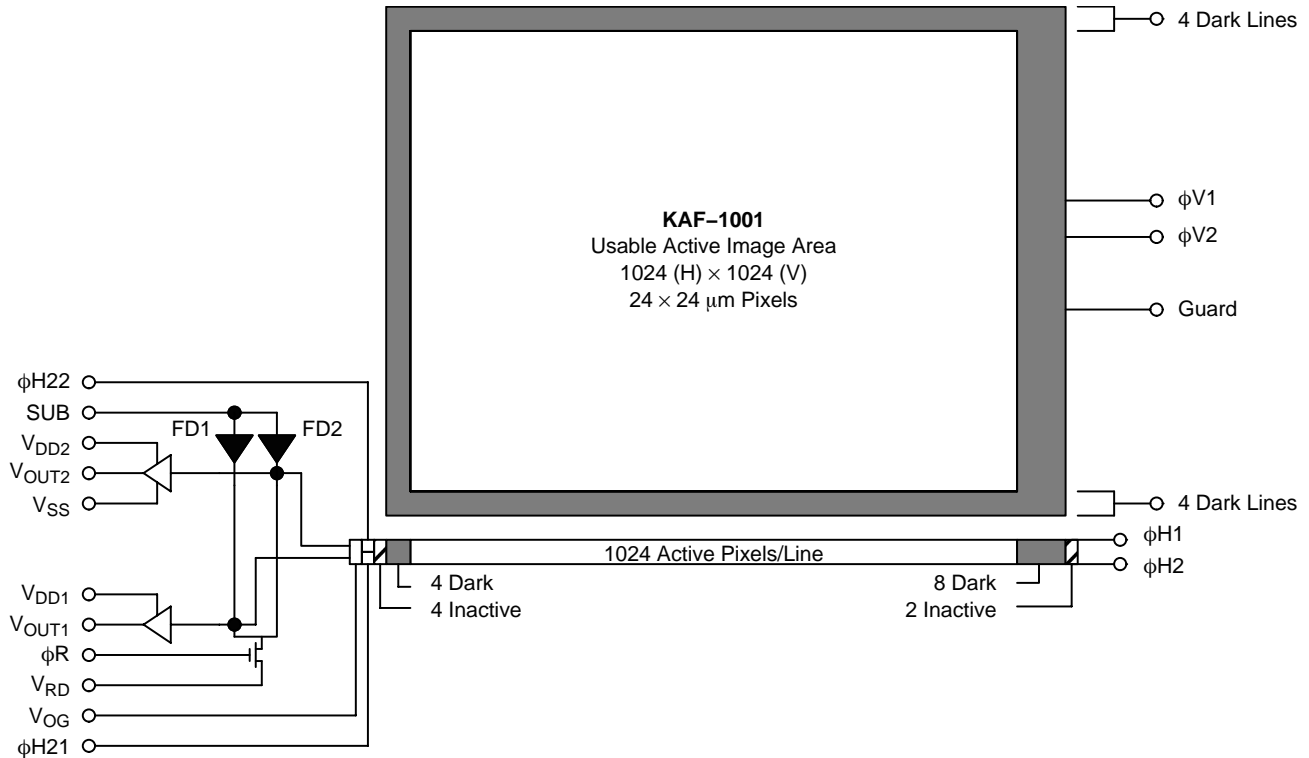

NOTE: Shaded areas represent 4 non-imaging pixels at the beginning and 8 non-imaging pixels at the end of each line. There are also 4 non-imaging lines at the top and bottom of each frame.

Figure 2. Block Diagram

Refer to the block diagram in Figure 2. The KAF-1001 consists of one vertical (parallel) CCD shift register, one horizontal (serial) CCD shift register and a selectable high or low gain output amplifier. Both registers incorporate true two-phase buried channel technology. The vertical register consists of  $24 \mu\text{m} \times 24 \mu\text{m}$  photo-capacitor sensing elements (pixels) which also serves as the transport mechanism. The pixels are arranged in a  $1024 (H) \times 1024 (V)$  array; an additional 12 columns (4 at the left and 8 at the right) and 8 rows (4 each at top and bottom) of non-imaging pixels are added as dark reference. Because there is no storage array, this device must be synchronized with strobe illumination or shuttered during readout.

#### Output Structure

The final gate of the horizontal register is split into two sections,  $\phi H21$  and  $\phi H22$ . The split gate structure allows the

user to select either of the two output amplifiers. To use the high dynamic range single-stage output ( $V_{OUT1}$ ), tie  $\phi H22$  to a negative voltage to block charge transfer, and tie  $\phi H21$  to  $\phi H2$  to transfer charge. To use the high sensitivity two-stage output ( $V_{OUT2}$ ), tie  $\phi H21$  to a negative voltage and  $\phi H22$  to  $\phi H2$ . The charge packets are then dumped onto the appropriate floating diffusion output node whose potential varies linearly with the quantity of charge in each packet. The amount of potential change is determined by the simple expression  $\Delta V_{fd} = \Delta Q/C_{fd}$ . The translation from electrons to voltages is called the output sensitivity or charge-to-voltage conversion. After the output has been sensed off-chip, the reset clock ( $\phi R$ ) removes the charge from the floating diffusion via the reset drain ( $V_{RD}$ ). This, in turn, returns the floating diffusion potential to the reference level determined by the reset drain voltage.

# KAF-1001

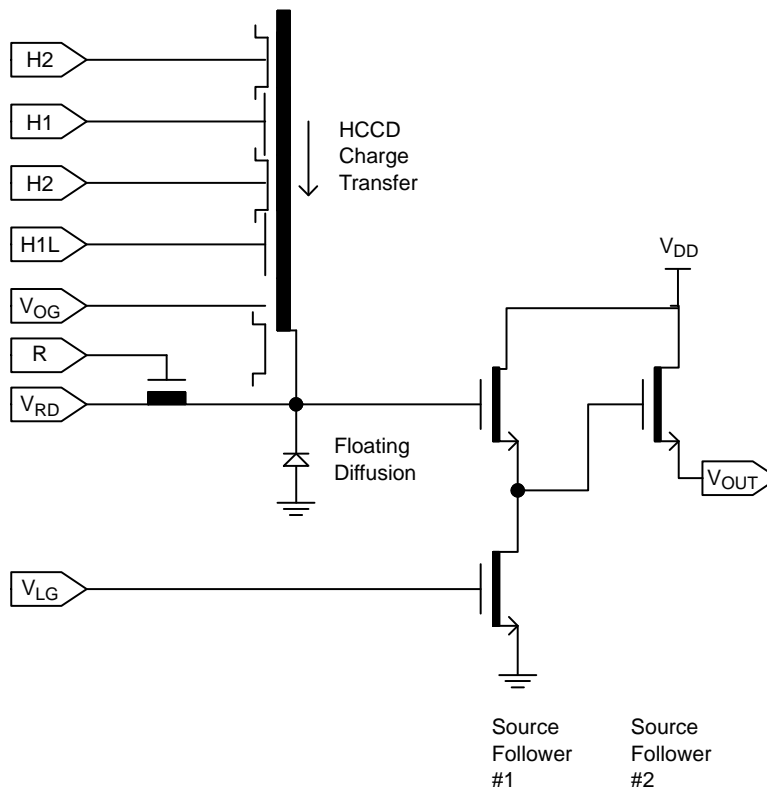

Figure 3. Output Schematic

## Image Acquisition

An image is acquired when incident light, in the form of photons, falls on the array of pixels in the vertical CCD register and creates electron-hole pairs (or simply electrons) within the silicon substrate. This charge is collected locally by the formation of potential wells created at each pixel site by induced voltages on the vertical register clock lines ( $\phi V1$ ,  $\phi V2$ ). These same clock lines are used to implement the transport mechanism as well. The amount of charge collected at each pixel is linearly dependent on light level and exposure time and non-linearly dependent on wavelength until the potential well capacity is exceeded. At this point charge will 'bloom' into vertically adjacent pixels.

## Charge Transport

Integrated charge is transported to the output in a two-step process. Rows of charge are first shifted line by line into the horizontal CCD. 'Lines' of charge are then shifted to the output pixel by pixel. Referring to the timing diagram,

integration of charge is performed with  $\phi V1$  and  $\phi V2$  held low. Transfer to horizontal CCD begins when  $\phi V1$  is brought high causing charge from the  $\phi V1$  and  $\phi V2$  gates to combine under the  $\phi V1$  gate.

$\phi V1$  and  $\phi V2$  now reverse their polarity causing the charge packets to 'spill' forward under the  $\phi V2$  gate of the next pixel. The rising edge of  $\phi V2$  also transfers the first line of charge into the horizontal CCD. A second phase transition places the charge packets under the  $\phi V1$  electrode of the next pixel. The sequence completes when  $\phi V1$  is brought low. Clocking of the vertical register in this way is known as accumulation mode clocking. Next, the horizontal CCD reads out the first line of charge using traditional complementary clocking (using  $\phi H1$  and  $\phi H2$  pins) as shown. The falling edge of  $\phi H2$  forces a charge packet over the output gate (OG) onto one of the output nodes (floating diffusion) which controls the output amplifier. The cycle repeats until all lines are read.

Physical Description

Pin Description and Device Orientation

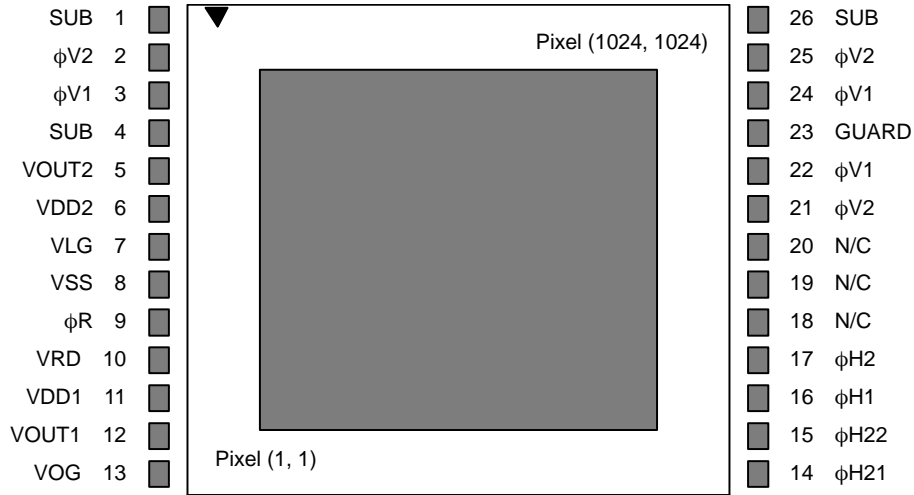

Figure 4. Pinout Diagram

Table 4. PIN DESCRIPTION

Pin	Name	Description
1	SUB	Substrate
2	$\phi V2$	Vertical (Parallel) CCD Clock – Phase 2
3	$\phi V1$	Vertical (Parallel) CCD Clock – Phase 1
4	SUB	Substrate
5	VOUT2	Video Output from High Sensitivity Two-Stage Amplifier
6	VDD2	High Sensitivity Two-Stage Amplifier Supply
7	VLG	First Stage Load Transistor Gate for Two-Stage Amplifier
8	VSS	Output Amplifier Return
9	$\phi R$	Reset Clock
10	VRD	Reset Drain
11	VDD1	High Dynamic Range Single-Stage Amplifier Supply
12	VOUT1	Video Output from High Dynamic Range Single-Stage Amplifier
13	VOG	Output Gate

Pin	Name	Description
14	$\phi H21$	Last Horizontal (Serial) CCD Phase – Split Gate
15	$\phi H22$	Last Horizontal (Serial) CCD Phase – Split Gate
16	$\phi H1$	Horizontal (Serial) CCD Clock – Phase 1
17	$\phi H2$	Horizontal (Serial) CCD Clock – Phase 2
18	N/C	No Connection
19	N/C	No Connection
20	N/C	No Connection
21	$\phi V2$	Vertical (Parallel) CCD Clock – Phase 2
22	$\phi V1$	Vertical (Parallel) CCD Clock – Phase 1
23	GUARD	Guard Ring
24	$\phi V1$	Vertical (Parallel) CCD Clock – Phase 1
25	$\phi V2$	Vertical (Parallel) CCD Clock – Phase 2
26	SUB	Substrate

1. Pins 3, 22, and 24 must be connected together – only one Phase 1 clock driver is required.
2. Pins 2, 21, and 25 must be connected together – only one Phase 2 clock driver is required.

## IMAGING PERFORMANCE

### Typical Operational Conditions

All values derived using nominal operating conditions with the recommended timing. Correlated doubling

sampling of the output is assumed and recommended. Many units are expressed in electrons: to convert to voltage, multiply by the amplifier sensitivity.

### Specifications

**Table 5. SPECIFICATIONS**

Description	Symbol	Min.	Nom.	Max.	Units	Notes	Verification Plan
<b>ELECTRO-OPTICAL</b>							
Optical Fill Factor	FF	–	100	–	%		
Photoresponse Non-uniformity	PRNU	–	–	5	% rms	Full Array	Die <sup>10</sup>
Quantum Efficiency (450, 550, 650 nm)	QE	–	–	–			Design <sup>11</sup>
<b>CCD PARAMETERS COMMON TO BOTH OUTPUTS</b>							
Sat. Signal – V <sub>CCD</sub> Register	Ne <sup>-</sup> <sub>SAT</sub>	450	500	–	ke <sup>-</sup>	2	Design <sup>11</sup>
Dark Current	J <sub>D</sub>	–	15.3 550	30 1,080	pA/cm <sup>2</sup> e <sup>-</sup> /pix/sec	25°C (Mean of All Pixels)	Die <sup>10</sup>
Dark Current Doubling Temp	DCDR	5	6	7	°C		Design <sup>11</sup>
Dark Signal Non-uniformity	DSNU	–	–	1,080	e <sup>-</sup> /pix/sec	4	Die <sup>10</sup>
Charge Transfer Efficiency	CTE	–	0.99997	–		5	Die <sup>10</sup>
V-H CCD Transfer Time	t <sub>VH</sub>	–	32	–	μs	6, 7	Design <sup>11</sup>
Blooming Suppression	B <sub>S</sub>	–	None	–			
<b>CCD PARAMETERS SPECIFIC TO HIGH OUTPUT AMPLIFIER</b>							
Output Sensitivity	V <sub>OUT</sub> /Ne <sup>-</sup>	9	11	–	μV/e <sup>-</sup>		Design <sup>11</sup>
Sat. Signal	Ne <sup>-</sup> <sub>SAT</sub>	180	200	240	ke <sup>-</sup>	1	Design <sup>11</sup>
Total Sensor Noise	ne <sup>-</sup> <sub>TOTAL</sub>	–	13	20	e <sup>-</sup> rms	8	Design <sup>11</sup>
Horizontal CCD Frequency	f <sub>H</sub>	–	2	5	MHz	6	Design <sup>11</sup>
Dynamic Range	DR	79	83	–	dB	9	Design <sup>11</sup>
<b>CCD PARAMETERS SPECIFIC TO LOW GAIN (HIGH DYNAMIC RANGE) OUTPUT AMPLIFIER</b>							
Output Sensitivity	V <sub>OUT</sub> /Ne <sup>-</sup>	1.7	2		μV/e <sup>-</sup>		Die <sup>10</sup>
Sat. Signal	Ne <sup>-</sup> <sub>SAT</sub>	1,400	1,500	1,800	ke <sup>-</sup>	3	Design <sup>11</sup>
Total Sensor Noise	ne <sup>-</sup> <sub>TOTAL</sub>	–	22	30	e <sup>-</sup> rms	8	Die <sup>10</sup>
Horizontal CCD Frequency	f <sub>H</sub>	–	0.5	2	MHz	6	Design <sup>11</sup>
Dynamic Range	DR	93	97	–	dB	9	Design <sup>11</sup>

1. Point where the output saturates when operated with nominal voltages.
2. Signal level at the onset of blooming in the vertical (parallel) CCD register.
3. Maximum signal level at the output of the high dynamic range output. This signal level will only be achieved when binning pixels containing large signals.
4. None of 64 sub arrays (128 × 128) exceed the maximum dark current specification.
5. For 2 MHz data rate and T = 30°C to –40°C.
6. Using maximum CCD frequency and/or minimum CCD transfer times may compromise performance.
7. Time between the rising edge of φV1 and the first falling edge of φH1.
8. At T<sub>INTEGRATION</sub> = 0; data rate = 1 MHz; temperature = –30°C.
9. Uses 20LOG (Ne<sup>-</sup><sub>SAT</sub> / ne<sup>-</sup><sub>TOTAL</sub>) where Ne<sup>-</sup><sub>SAT</sub> refers to the amplifier saturation signal.
10. A parameter that is measured on every sensor during production testing.
11. A parameter that is quantified during the design verification activity.

# KAF-1001

## TYPICAL PERFORMANCE CURVES

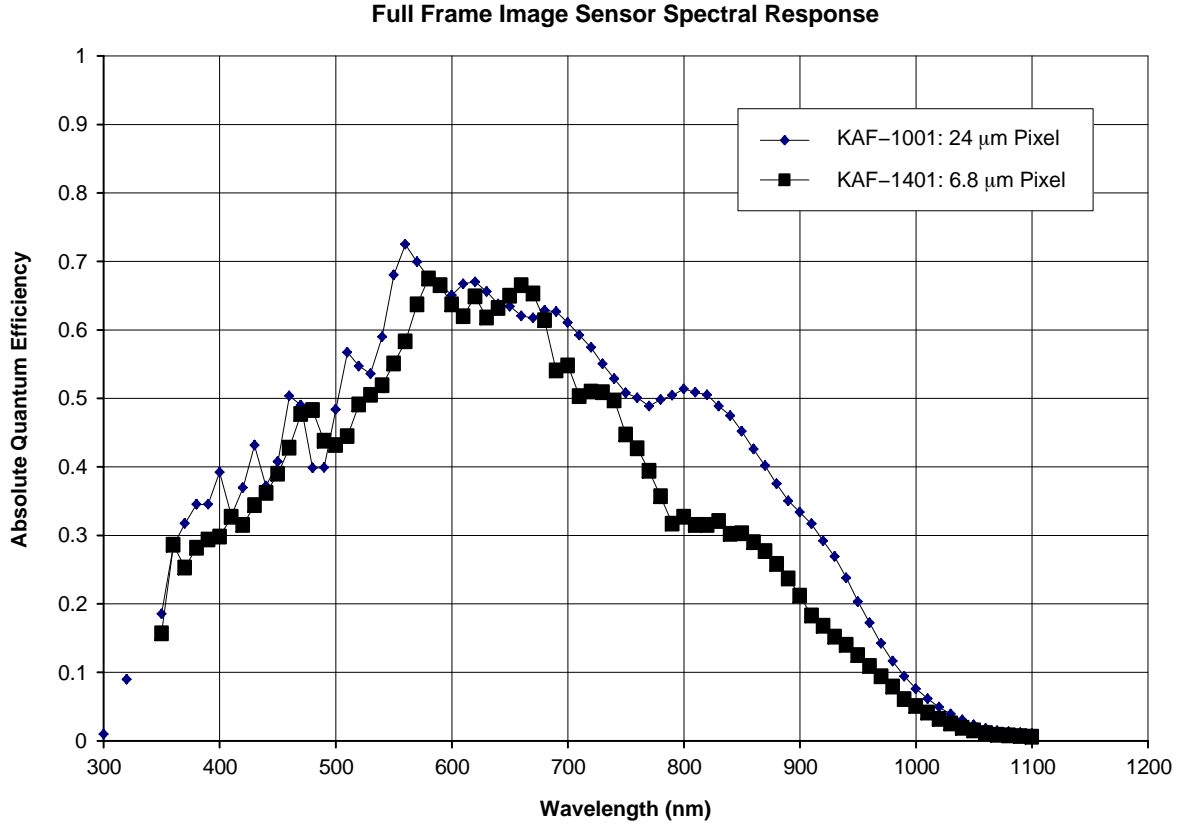

**Figure 5. Typical Spectral Response**

Figure 5 shows a representative spectral response of front side illuminated transparent gate full frame image sensors. The KAF-1001 with 24 μm pixels has higher response than the 6.8 μm pixel sensor at wavelengths greater than 750 nm because it is constructed on a lower resistivity silicon substrate. The resulting collection volume of each pixel more efficiently collects signal generated deeper within the silicon.

Most of the two phase CCD pixels are designed so that each of the electrodes occupies half of the pixel area. The KAF-1001 was not designed this way but instead is designed with the transparent electrode occupying greater than half the pixel area. This further improves the benefits of the transparent gate.

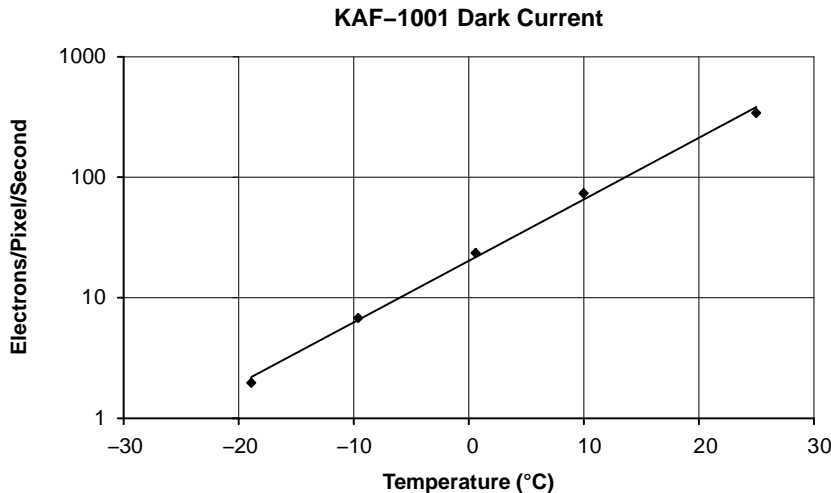

**Figure 6. Dark Current as a Function of Temperature**

**DEFECT DEFINITIONS**

**Table 6. SPECIFICATIONS**

Grade	Point Defect	Cluster Defect	Column Defect
C1	20	2	0
C2	40	10	2

*Point Defects*

**Dark:** A pixel which deviates by more than 20% from neighboring pixels when illuminated to 70% of saturation.

**Bright:** A pixel whose dark current exceeds 4,500 e<sup>-</sup>/pix/sec at 25°C.

*Cluster Defect*

A grouping of not more than 5 adjacent point defects.

*Column Defect*

A grouping point defects along a single column (Dark column).

A column that contains a pixel whose dark current exceeds 150,000 e<sup>-</sup>/pix/sec at 25°C (Bright column).

A column that does not exhibit the minimum charge capacity specification (Low Charge capacity).

A column that loses > 500 electrons when the array is illuminated to a signal level of 2,000 e<sup>-</sup>/pix (Trap like defects).

*Neighboring Pixels*

The surrounding 128 × 128 pixels or ±64 columns/rows.

*Defect Separation*

Defects are separated by no less than 3 pixels in any one direction.

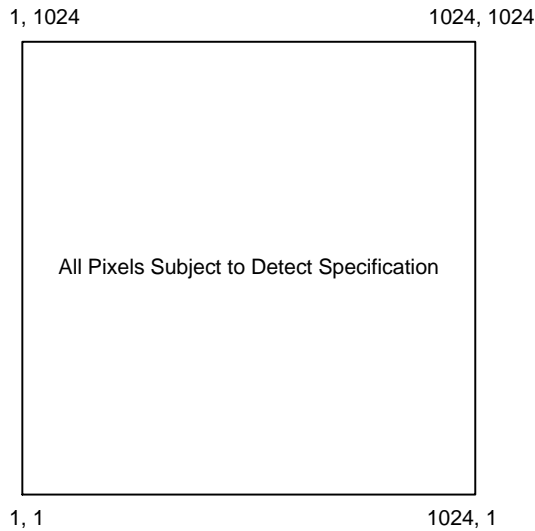

**Figure 7. Active Pixel Region**

# KAF-1001

## OPERATION

**Table 7. ABSOLUTE MAXIMUM RATINGS**

Description	Symbol	Minimum	Maximum	Units	Notes
Storage Temperature	$T_{ST}$	-100	+80	°C	At Device
Operating Temperature	$T_{OP}$	-50	+50	°C	At Device
Voltage	All Clocks	-16	+16	V	$V_{SUB} = 0$ V
Voltage	OG	0	+8	V	$V_{SUB} = 0$ V
Voltage	$V_{RD}$ , $V_{SS}$ , $V_{DD}$ , GUARD	0	+20	V	$V_{SUB} = 0$ V
Current	Output Bias Current ( $I_{DD}$ )	-	10	mA	
Capacitance	Output Load Capacitance ( $C_{LOAD}$ )	-	10	pF	
Frequency/Time	$\phi V1$ , $\phi V2$ Pulse Width	8	-	$\mu$ s	
Frequency/Time	$\phi H1$ , $\phi H2$	-	5	MHz	
Frequency/Time	$\phi R$ Pulse Width	20	-	ns	

Stresses exceeding those listed in the Maximum Ratings table may damage the device. If any of these limits are exceeded, device functionality should not be assumed, damage may occur and reliability may be affected.

**Table 8. DC BIAS OPERATING CONDITIONS**

Description	Symbol	Minimum	Nominal	Maximum	Units	Pin Impedance	Notes
Substrate	$V_{SUB}$	0.0	0.0	0.0	V	Common	
Output Amplifier Supply	$V_{DD}$	15.0	17.0	17.5	V	5 pF, 2 k $\Omega$	1
Output Amplifier Return	$V_{SS}$	1.4	2.0	2.1	V	5 pF, 2 k $\Omega$	
Reset Drain	$V_{RD}$	11.5	12.0	12.5	V	5 pF, 1 M $\Omega$	
Output Gate	OG	3.0	4.0	4.5	V	5 pF, 10 M $\Omega$	
Guard Ring	GUARD	7.0	10.0	15.0	V	350 pF, 10 M $\Omega$	
Load Gate	$V_{LG}$	$V_{SS} - 0.5$	$V_{SS}$	$V_{SS} + 1.0$	V		

- $V_{DD} = 17$  V for applications where the expected output voltage > 2.0 V. For applications where the expected useable output voltage is < 2 V,  $V_{DD}$  can be reduced to 15 V.

## AC Operating Conditions

Table 9. CLOCK LEVELS

Description	Symbol	Level	Minimum	Nominal	Maximum	Units	Pin Impedance
Vertical CCD Clock – Phase 1	$\phi V1$	Low	-10.25	-10.0	-9.8	V	200 nF, 10 M $\Omega$
Vertical CCD Clock – Phase 1	$\phi V1$	High	0.0	0.0	1.0	V	
Vertical CCD Clock – Phase 2	$\phi V2$	Low	-10.25	-10.0	-9.8	V	200 nF, 10 M $\Omega$
Vertical CCD Clock – Phase 2	$\phi V2$	High	0.0	0.0	1.0	V	$C_{\phi V1-V2} = 100$ nF
Horizontal CCD Clock – Phase 1	$\phi H1$	Low	-2.2	-2.0	-1.8	V	400 pF, 10 M $\Omega$
Horizontal CCD Clock – Phase 1	$\phi H1$	High	7.8	8.0	8.2	V	
Horizontal CCD Clock – Phase 2	$\phi H2$	Low	-2.2	-2.0	-1.8	V	250 pF, 10 M $\Omega$
Horizontal CCD Clock – Phase 2	$\phi H2$	High	7.8	8.0	8.2	V	$C_{\phi H1-H2} = 200$ nF
Reset Clock	$\phi R$	Low	2.0	3.0	3.5	V	10 pF, 10 M $\Omega$
Reset Clock	$\phi R$	High	9.5	10.0	11.0	V	

Description	Symbol	Level	Using the High Gain Output ( $V_{OUT2}$ )			Using the High Dynamic Range Output ( $V_{OUT1}$ )			Units	Pin Impedance
			Min.	Nom.	Max.	Min.	Nom.	Max.		
Horizontal Clock – Phase 1	$\phi H21$	Low	-4	$\phi H2$ Low	$\phi H2$ Low	-	$\phi H2$	-	V	10 pF, 10 M $\Omega$
Horizontal Clock – Phase 1	$\phi H21$	High	-4	$\phi H2$ Low	$\phi H2$ Low	-	$\phi H2$	-	V	
Horizontal Clock – Phase 2	$\phi H22$	Low	-	$\phi H2$	-	-	$\phi H2$ Low	$\phi H2$ Low	V	10 pF, 10 M $\Omega$
Horizontal Clock – Phase 2	$\phi H22$	High	-	$\phi H2$	-	-	$\phi H2$ Low	$\phi H2$ Low	V	

1. When using  $V_{OUT1}$ ,  $\phi H21$  is clocked identically with  $\phi H2$  while  $\phi H22$  is held at a static level. When using  $V_{OUT2}$ ,  $\phi H21$  and  $\phi H22$  are exchanged so that  $\phi H22$  is identical to  $\phi H2$  and  $\phi H21$  is held at a static level. The static level should be the same voltage as  $\phi H2$  low.
2. The AC and DC operating levels are for room temperature operation. Operation at other temperatures may require adjustments of these voltages. Pins shown with impedances greater than 1 M $\Omega$  are expected resistances. These pins are only verified to 1 M $\Omega$ .
3.  $\phi V1, 2$  capacitances are accumulated gate oxide capacitance, and are an over-estimate of the capacitance.
4. This device is suitable for a wide range of applications requiring a variety of different operating conditions. Consult ON Semiconductor in those situations in which operating conditions meet or exceed minimum or maximum levels.

## TIMING

Table 10. REQUIREMENTS AND CHARACTERISTICS

Description	Symbol	Minimum	Nominal	Maximum	Units	Notes
$\phi$ H1, $\phi$ H2 Clock Frequency	$f_H$	–	4	5	MHz	1, 2, 3
$\phi$ V1, $\phi$ V2 Clock Frequency	$f_V$	–	100	125	kHz	1, 2, 3
Pixel Period (1 Count)	$t_{PIX}$	200	250	–	ns	
$\phi$ H1, $\phi$ H2 Setup Time	$t_{\phi HS}$	500	1,000	–	ns	
$\phi$ V1, $\phi$ V2 Clock Pulse Width	$t_{\phi V}$	4	5	–	$\mu$ s	2
Reset Clock Pulse Width	$t_{\phi R}$	20	60	–	ns	4
Readout Time	$t_{READOUT}$	226	286	–	ms	5
Integration Time	$t_{INT}$	–	–	–		6
Line Time	$t_{LINE}$	219	277	–	$\mu$ s	7

1. 50% duty cycle values.
2. CTE may degrade above the nominal frequency.
3. Rise and fall times (10/90% levels) should be limited to 5–10% of clock period. Crossover of register clocks should be between 40–60% of amplitude.
4.  $\phi$ R should be clocked continuously.
5.  $t_{READOUT} = (1032 * t_{LINE})$
6. Integration time ( $t_{INT}$ ) is user specified. Longer integration times will degrade noise performance due to dark signal fixed pattern and shot noise.
7.  $t_{LINE} = (3 * t_{\phi V}) + t_{\phi HS} + (1044 * t_{PIX}) + t_{PIX}$

# KAF-1001

## Normal Readout

### Frame Timing Detail

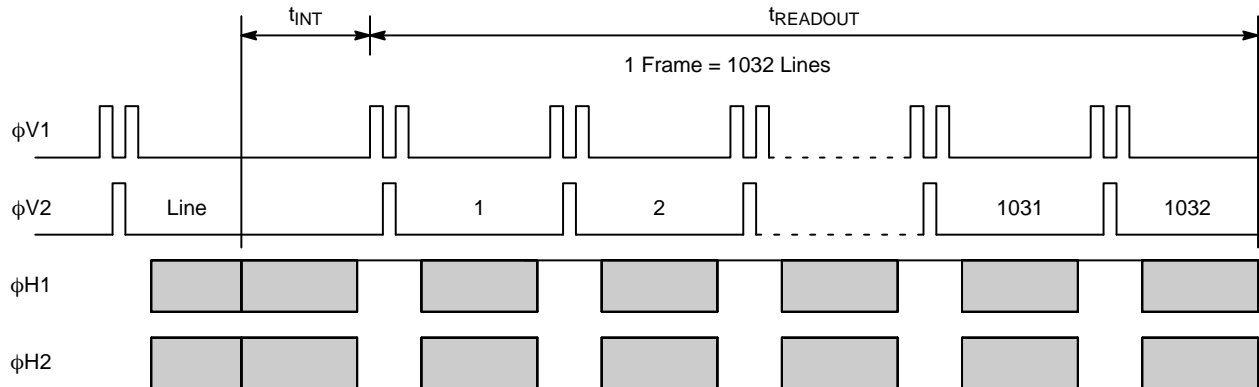

### Line Timing Detail

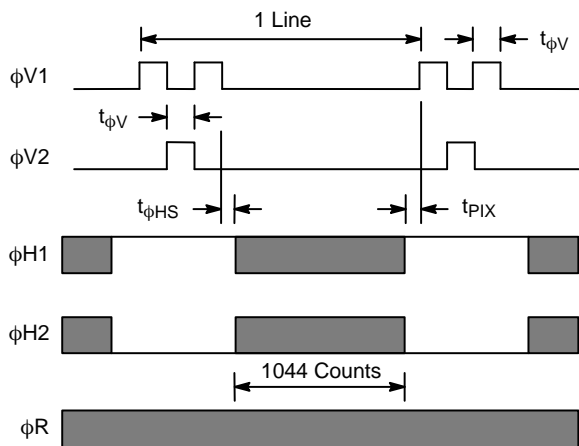

### Line Content

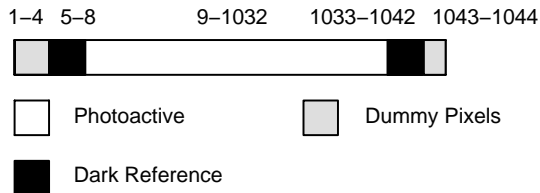

### Pixel Timing Detail

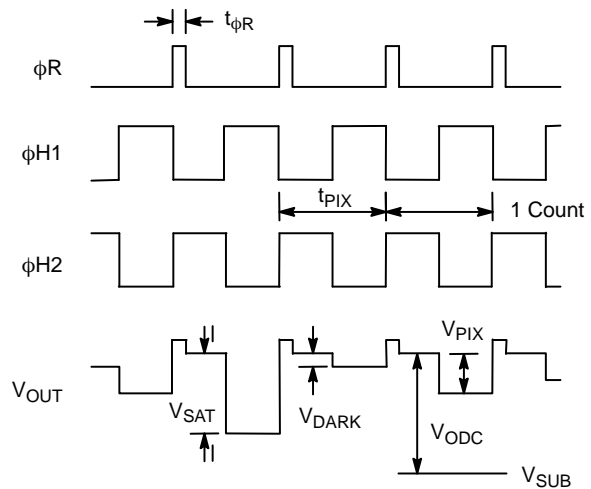

- $V_{SAT}$  Saturated pixel video output signal
- $V_{DARK}$  Video output signal in no-light situation, not zero due to  $J_{DARK}$
- $V_{PIX}$  Pixel video output signal level, more electrons = more negative
- $V_{ODC}$  Video level offset with respect to  $V_{SUB}$ \*
- $V_{SUB}$  Analog ground

\* See Image Acquisition section.

Figure 8. Timing Diagram

NOTE: This device is suitable for a wide range of applications requiring a variety of different timing frequencies. Therefore, only maximum and minimum values are shown above. Consult ON Semiconductor in those situations that require special consideration.

## STORAGE AND HANDLING

Table 11. STORAGE CONDITIONS

Description	Symbol	Minimum	Maximum	Units	Notes
Storage Temperature	T <sub>ST</sub>	-100	+80	°C	At Device
Operating Temperature	T <sub>OP</sub>	-50	90	°C	

For information on ESD and cover glass care and cleanliness, please download the *Image Sensor Handling and Best Practices* Application Note (AN52561/D) from [www.onsemi.com](http://www.onsemi.com).

For information on soldering recommendations, please download the *Soldering and Mounting Techniques Reference Manual* (SOLDERRM/D) from [www.onsemi.com](http://www.onsemi.com).

For quality and reliability information, please download the *Quality & Reliability Handbook* (HBD851/D) from [www.onsemi.com](http://www.onsemi.com).

For information on device numbering and ordering codes, please download the *Device Nomenclature* technical note (TND310/D) from [www.onsemi.com](http://www.onsemi.com).

For information on Standard terms and Conditions of Sale, please download [Terms and Conditions](http://www.onsemi.com) from [www.onsemi.com](http://www.onsemi.com).

MECHANICAL INFORMATION

Completed Assembly

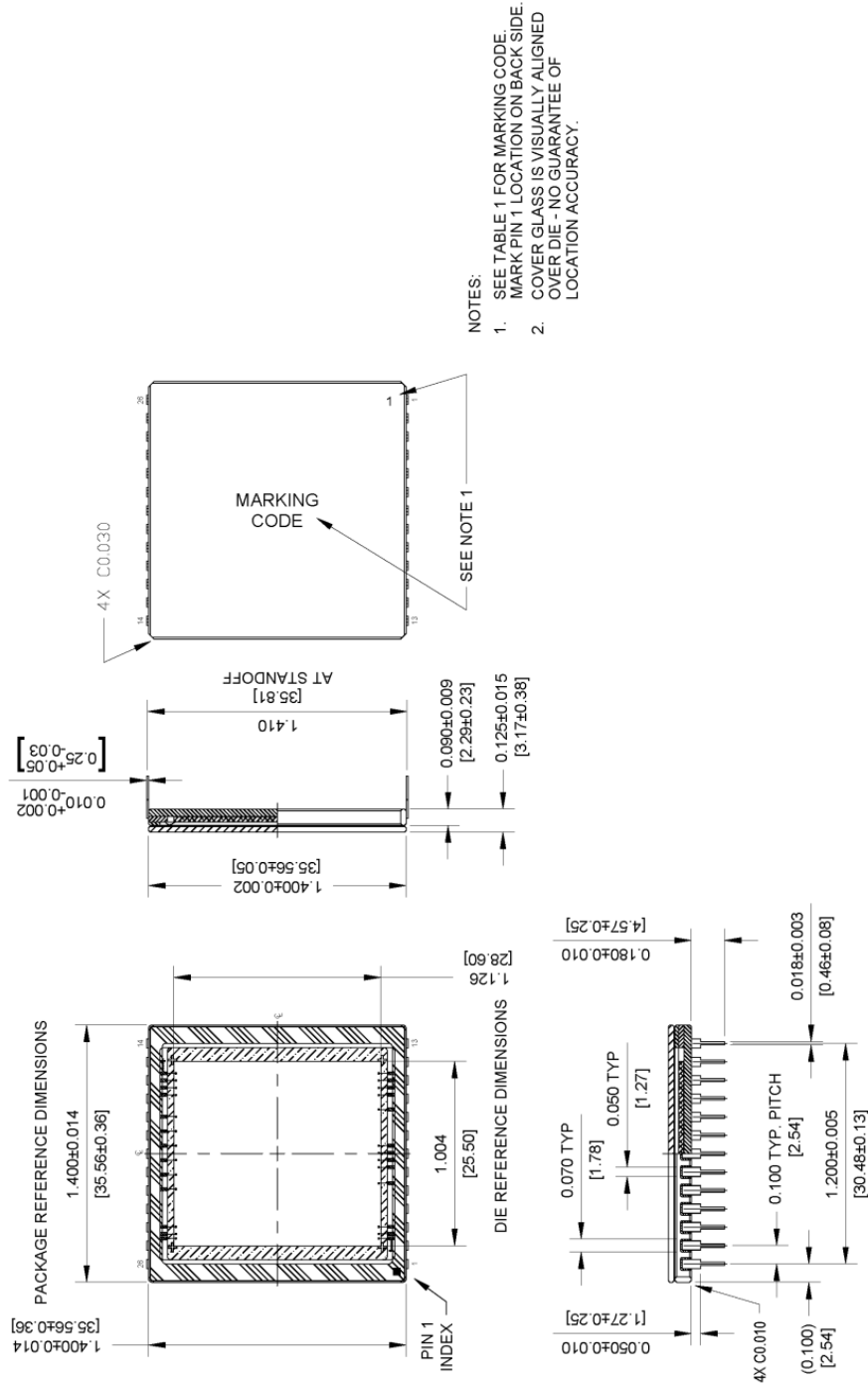

Figure 9. Completed Assembly (1 of 2)

# KAF-1001

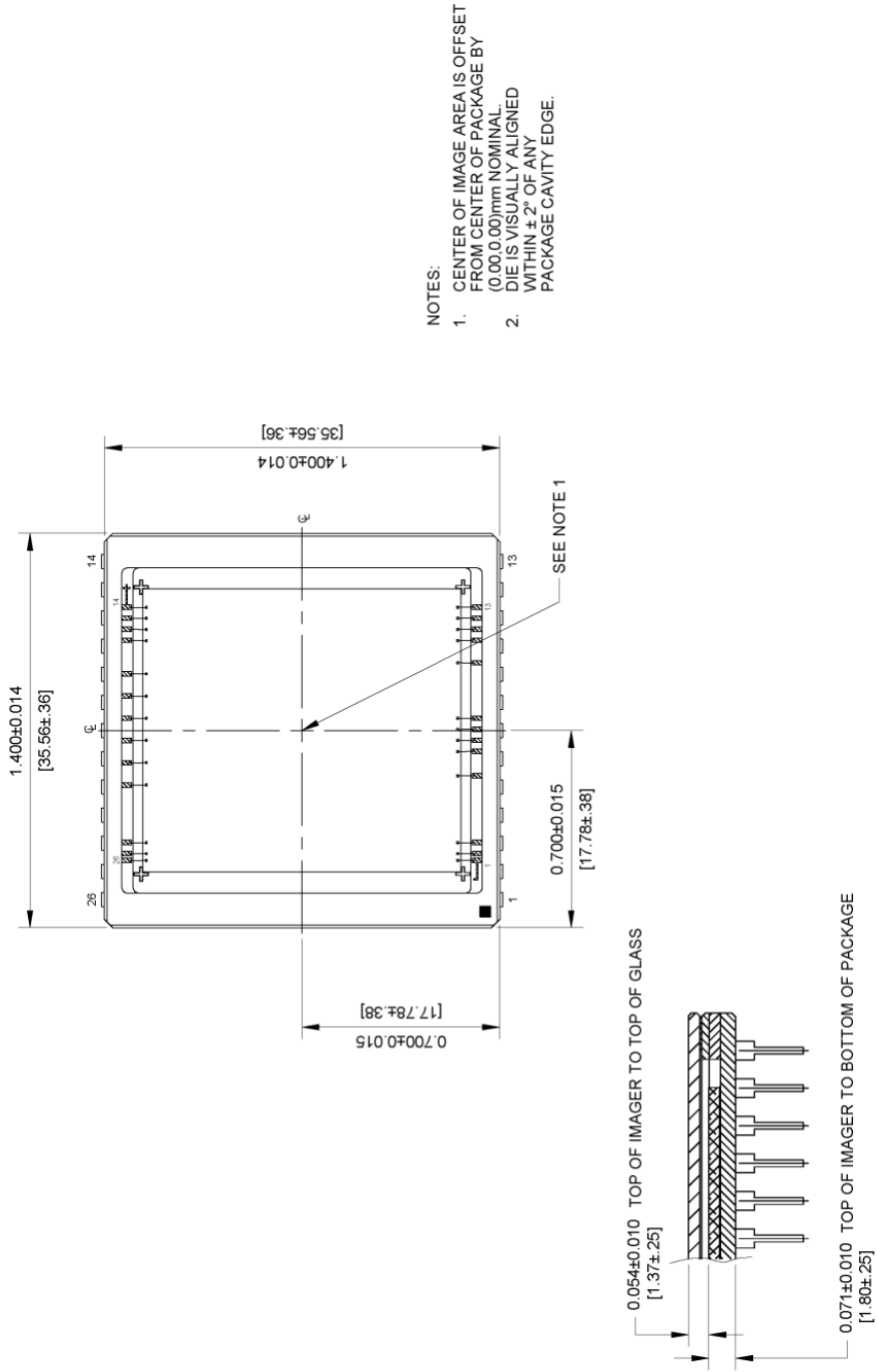



Figure 10. Completed Assembly (2 of 2)

ON Semiconductor and the  are registered trademarks of Semiconductor Components Industries, LLC (SCILLC) or its subsidiaries in the United States and/or other countries. SCILLC owns the rights to a number of patents, trademarks, copyrights, trade secrets, and other intellectual property. A listing of SCILLC's product/patent coverage may be accessed at [www.onsemi.com/site/pdf/Patent-Marking.pdf](http://www.onsemi.com/site/pdf/Patent-Marking.pdf). SCILLC reserves the right to make changes without further notice to any products herein. SCILLC makes no warranty, representation or guarantee regarding the suitability of its products for any particular purpose, nor does SCILLC assume any liability arising out of the application or use of any product or circuit, and specifically disclaims any and all liability, including without limitation special, consequential or incidental damages. "Typical" parameters which may be provided in SCILLC data sheets and/or specifications can and do vary in different applications and actual performance may vary over time. All operating parameters, including "Typicals" must be validated for each customer application by customer's technical experts. SCILLC does not convey any license under its patent rights nor the rights of others. SCILLC products are not designed, intended, or authorized for use as components in systems intended for surgical implant into the body, or other applications intended to support or sustain life, or for any other application in which the failure of the SCILLC product could create a situation where personal injury or death may occur. Should Buyer purchase or use SCILLC products for any such unintended or unauthorized application, Buyer shall indemnify and hold SCILLC and its officers, employees, subsidiaries, affiliates, and distributors harmless against all claims, costs, damages, and expenses, and reasonable attorney fees arising out of, directly or indirectly, any claim of personal injury or death associated with such unintended or unauthorized use, even if such claim alleges that SCILLC was negligent regarding the design or manufacture of the part. SCILLC is an Equal Opportunity/Affirmative Action Employer. This literature is subject to all applicable copyright laws and is not for resale in any manner.

## PUBLICATION ORDERING INFORMATION

### LITERATURE FULFILLMENT:

Literature Distribution Center for ON Semiconductor  
19521 E. 32nd Pkwy, Aurora, Colorado 80011 USA  
**Phone:** 303-675-2175 or 800-344-3860 Toll Free USA/Canada  
**Fax:** 303-675-2176 or 800-344-3867 Toll Free USA/Canada  
**Email:** [orderlit@onsemi.com](mailto:orderlit@onsemi.com)

**N. American Technical Support:** 800-282-9855 Toll Free  
USA/Canada  
**Europe, Middle East and Africa Technical Support:**  
Phone: 421 33 790 2910  
**Japan Customer Focus Center**  
Phone: 81-3-5817-1050

**ON Semiconductor Website:** [www.onsemi.com](http://www.onsemi.com)  
**Order Literature:** <http://www.onsemi.com/orderlit>  
For additional information, please contact your local  
Sales Representative

## Looking for pricing, stock, or lifecycle information?

Click below to explore more details on WIN SOURCE:

- ⊖ [View KAF-1001-AAA-CP-B2 on WIN SOURCE](#)
- ⊖ [ON Semiconductor Information](#)

## Optimize Your Supply Chain with WIN SOURCE Solutions

- ✓ Global Sourcing Solution
- ✓ Obsolete Management
- ✓ Cost Control Management
- ✓ Shortage Management
- ✓ Alternative Solution
- ✓ Excess Inventory Management