



**THE DATASHEET OF
RJS5K0E**



Rheostats

(Potentiometers) Wirewound

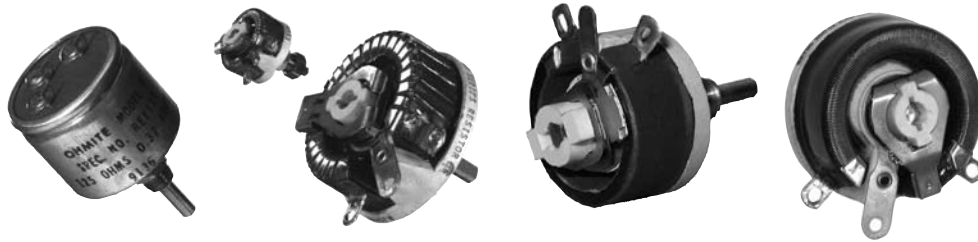

MODEL C

Model Type	Watts	Ohmic range	Core	Max. Voltage (RMS)*	Behind panel "B" (in./mm Ref.)	Diameter "D" (in./mm Ref.)	Dimension "C" (in./mm Ref.)	Shaft torque	Rotation (±5°)
C RCS/RCL	7.5	10.0-5K	enclosed	305	0.875/22.23	0.515/ 13.08	—	0.25-3 oz. in.	300°

• See Catalog #203 for complete details.

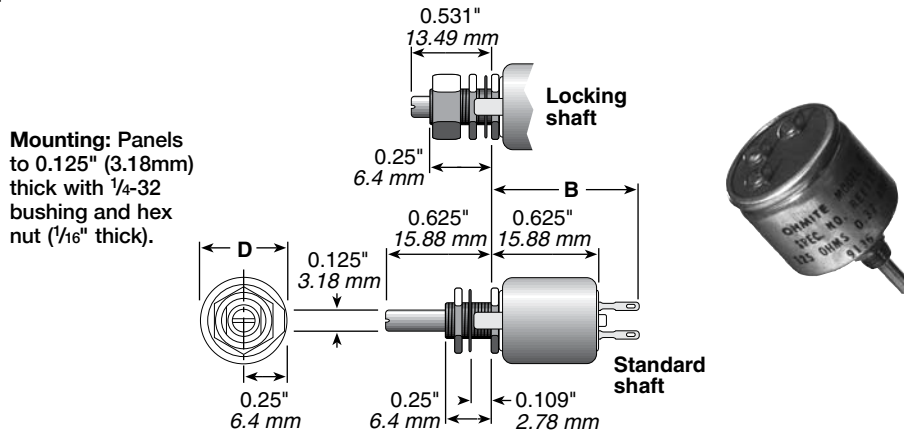

MODEL E

Model Type	Watts	Ohmic range	Core	Max. Voltage (RMS)*	Behind panel "B" (in./mm Ref.)	Diameter "D" (in./mm Ref.)	Dimension "C" (in./mm Ref.)	Shaft torque	Rotation (±5°)
E RES/REL	12.5	1.0-15K	open	305	0.688/17.46	0.875/ 22.23	0.594/15.08	1-6 oz. in.	300°
E REE	12.5	1.0-15K	enclosed	305	1.219/30.96	1.047/ 26.59	—	1-6 oz. in.	300°

• See Catalog #203 for complete details.

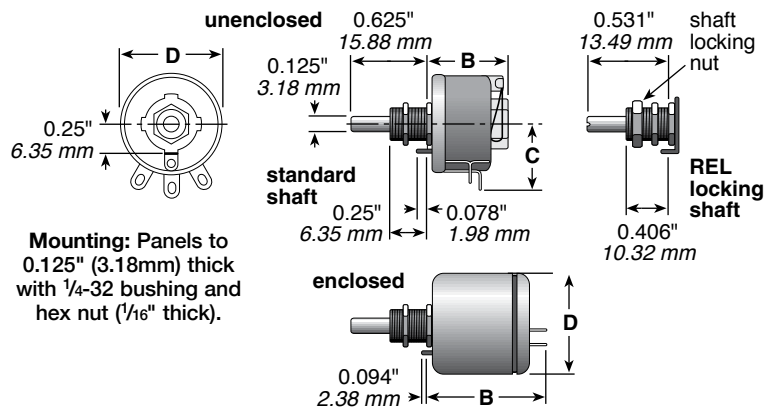

Dimensions for reference only; consult factory for details.

Since all rheostats/potentiometers are electro-mechanical devices, they are subject to mechanical wear and, therefore, have a finite life.

Models H, J, K, L and N are listed under UL File No. E-10946 and CSA File No. 21309 unless noted otherwise.

All rheostats are 10% tolerance.

Looking for pricing, stock, or lifecycle information?

Click below to explore more details on WIN SOURCE:

 [View RJS5K0E on WIN SOURCE](#)

 [Ohmite Information](#)

Optimize Your Supply Chain with WIN SOURCE Solutions

-  Global Sourcing Solution
-  Obsolete Management
-  Cost Control Management
-  Shortage Management
-  Alternative Solution
-  Excess Inventory Management